



United States Patent [19]

[11] Patent Number: **5,567,042**

Farchmin et al.

[45] Date of Patent: **Oct. 22, 1996**

[54] REFLECTOR FOR FLAT PANEL DISPLAY BACKLIGHT UNIT

4,794,501	12/1988	Bartenbach	362/217
4,947,305	8/1990	Gunter, Jr.	362/297
5,134,553	7/1992	Hasegawa	362/225
5,253,151	10/1993	Mephram et al.	362/297

[75] Inventors: **David W. Farchmin**, Grafton; **John S. Clark**, Cudahy, both of Wis.

FOREIGN PATENT DOCUMENTS

[73] Assignee: **Allen-Bradley Company, Inc.**, Milwaukee, Wis.

442246A2	8/1991	European Pat. Off.	362/297
1011484	12/1965	United Kingdom	362/217

[21] Appl. No.: **250,131**

Primary Examiner—Denise L. Gromada

Assistant Examiner—Alan B. Cariaso

[22] Filed: **May 27, 1994**

Attorney, Agent, or Firm—Mark W. Pfeiffer; John D. Franzini; John J. Horn

[51] Int. Cl.⁶ **F21V 7/09**

[52] U.S. Cl. **362/241; 362/29; 362/224; 362/225; 362/297; 362/346**

[58] Field of Search 362/224, 225, 362/237, 241, 245, 247, 260, 297, 346, 347, 348, 217, 29

[57] ABSTRACT

Backlighting for an LCD display is provided by a direct backlight unit which is hinged to the front panel in which the display is mounted. When closed, the backlight unit lamps and reflector transmit light directly against the back of the display. The reflector surfaces are made by a combination of constant radius, hyperbolic, parabolic and flat surfaces which maximize the emitted light transmitted to the display and help fill in for any failed or dimmed light sources.

[56] References Cited

U.S. PATENT DOCUMENTS

4,106,083	8/1978	Wolf	362/217
4,425,604	1/1984	Imai et al.	362/225
4,729,075	3/1988	Brass	362/217

20 Claims, 3 Drawing Sheets

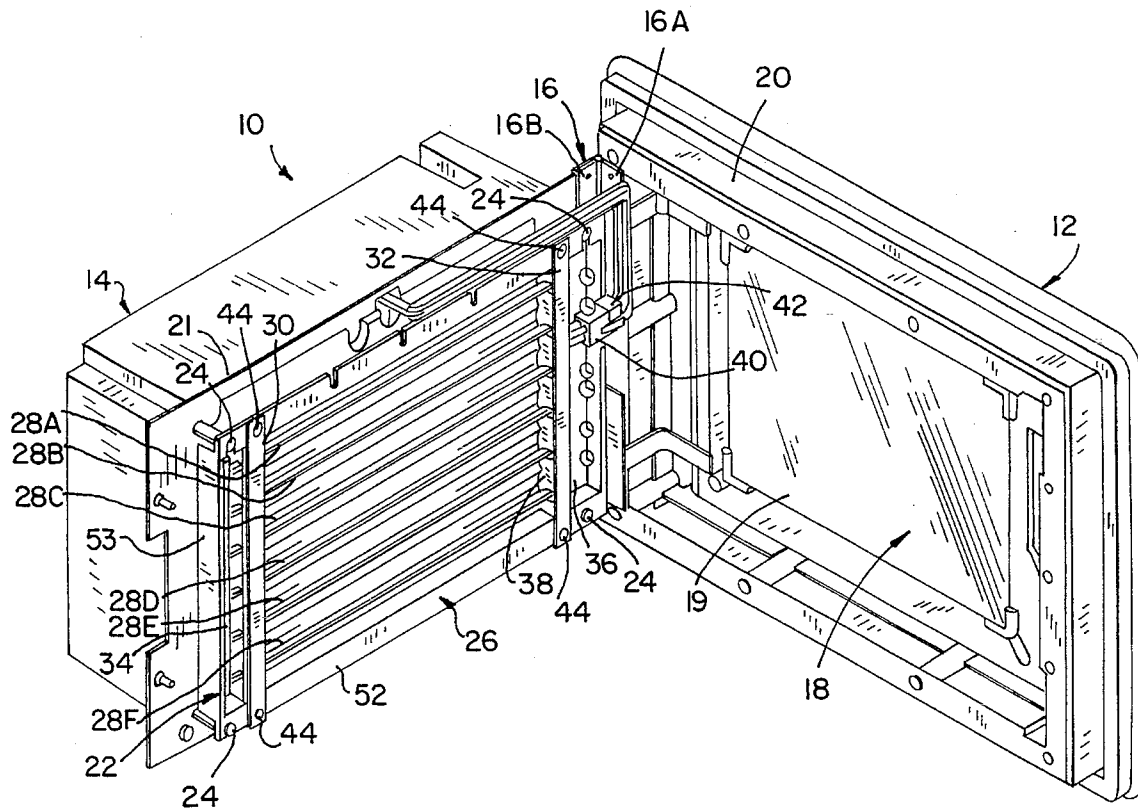

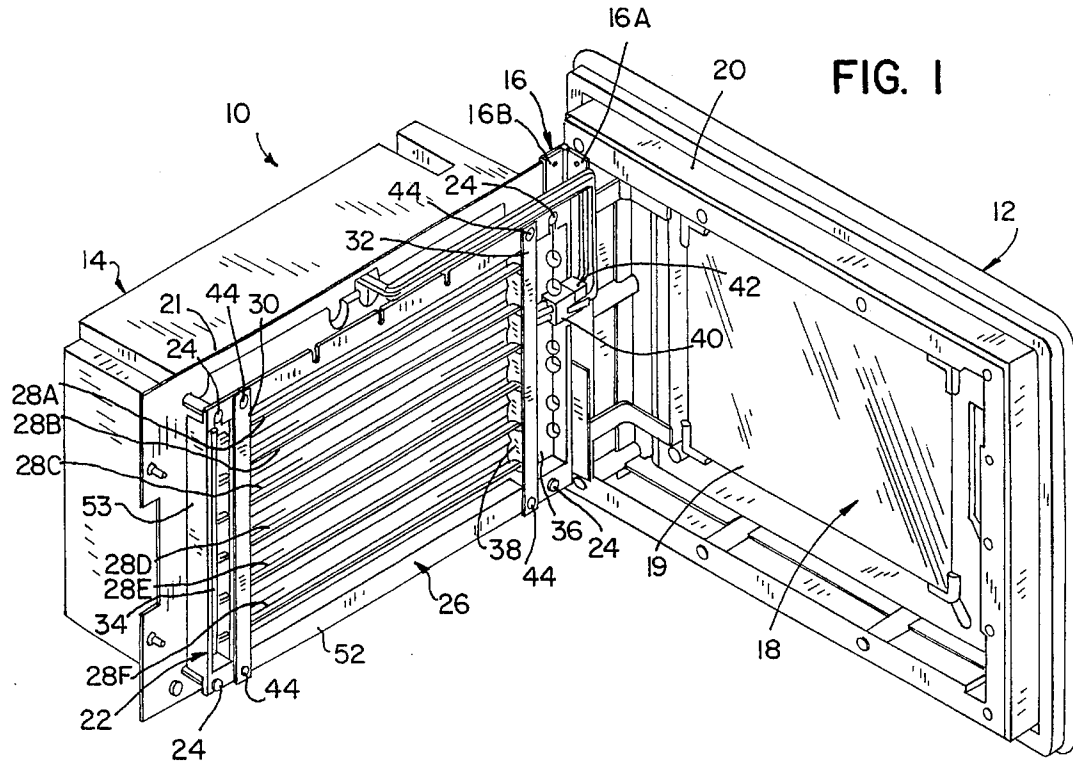
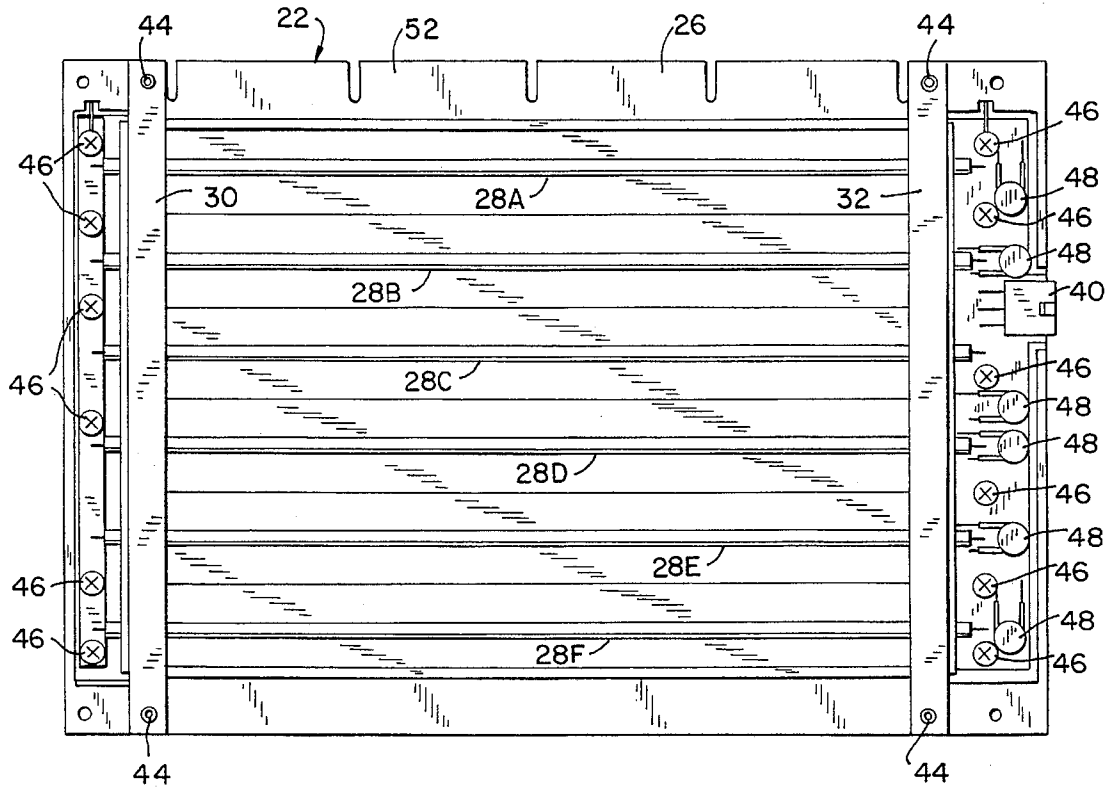

FIG. 2



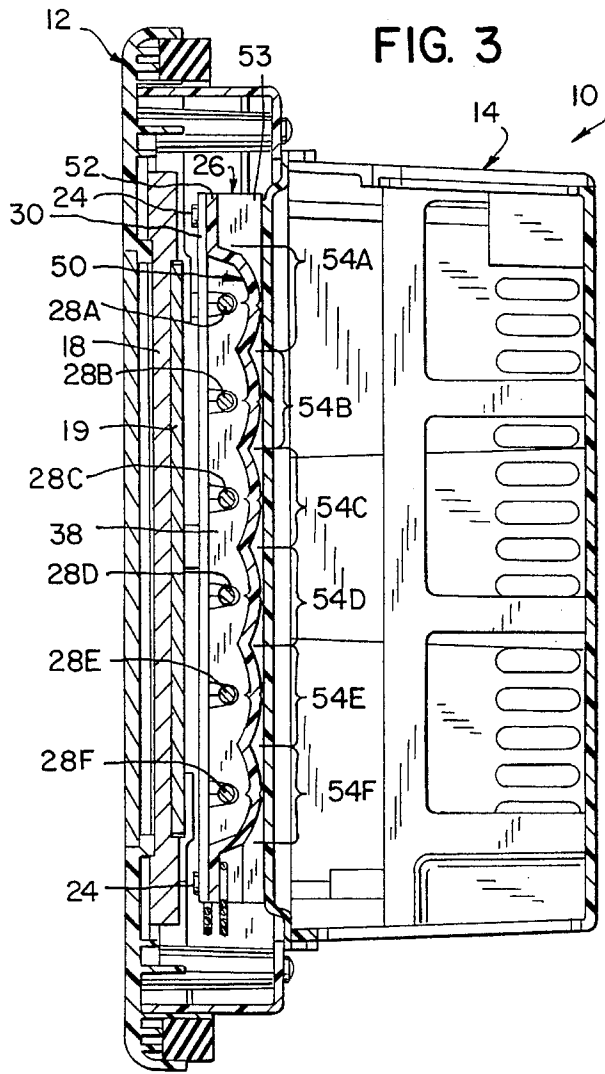

FIG. 3

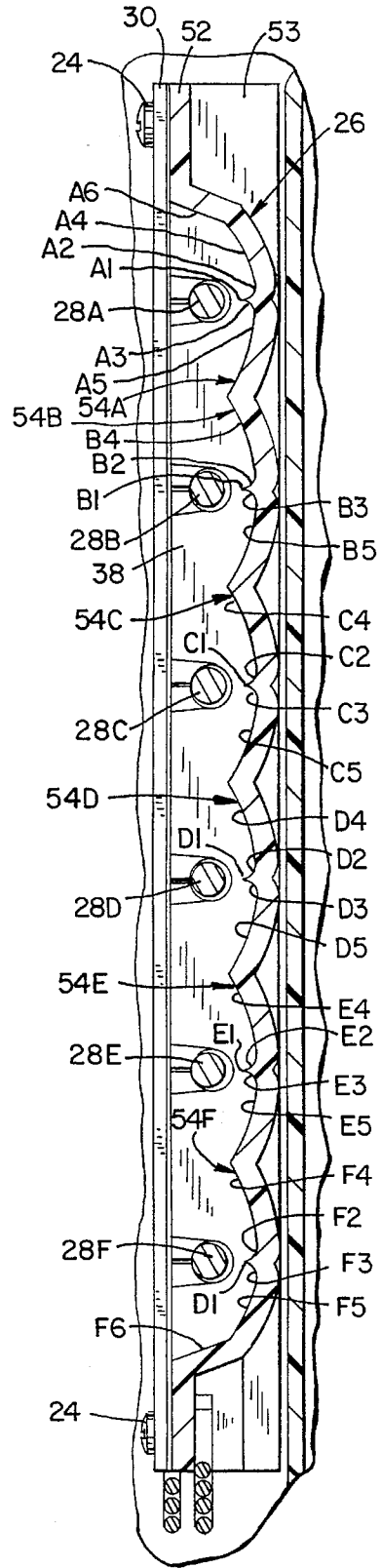
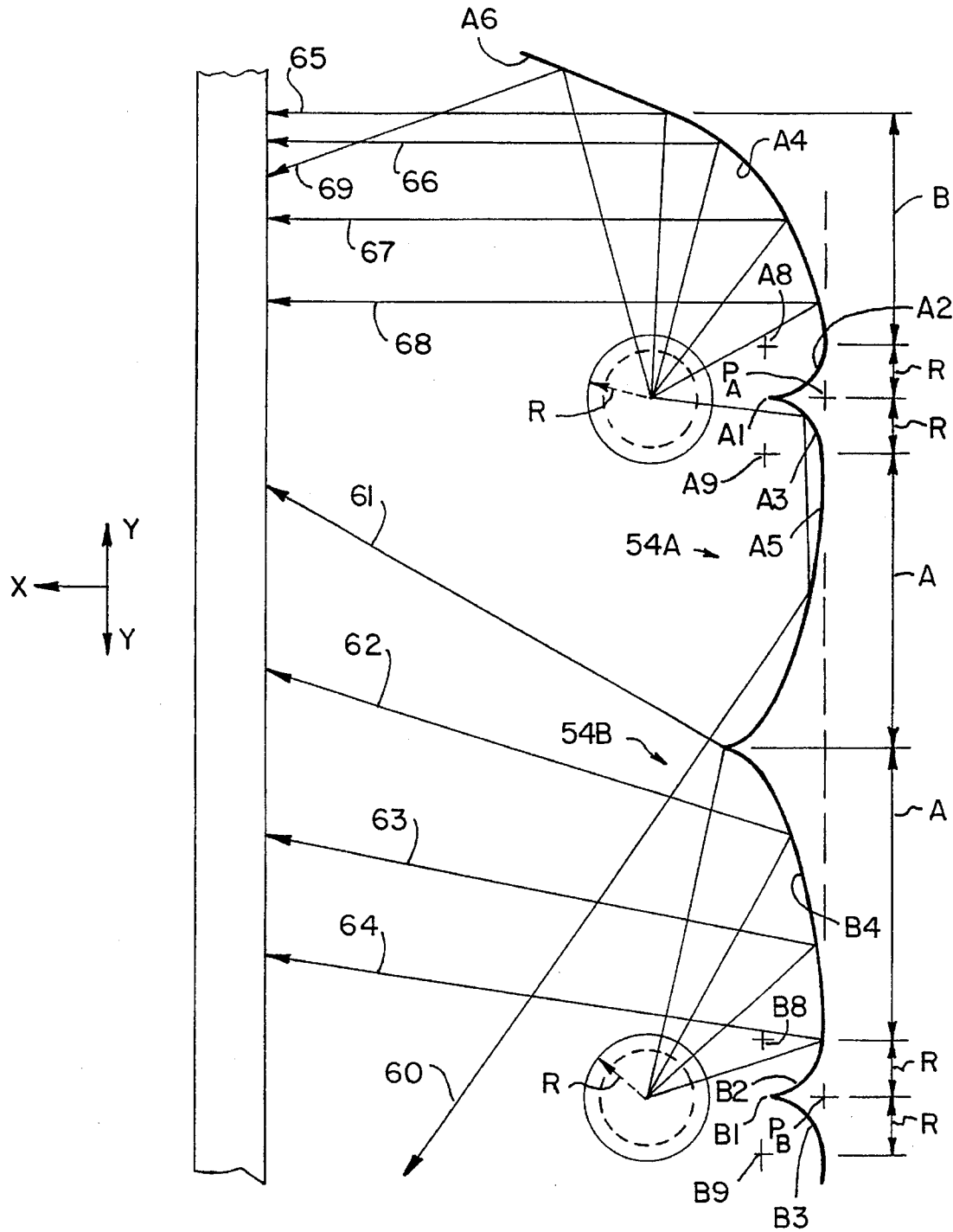

FIG. 4

FIG. 5



REFLECTOR FOR FLAT PANEL DISPLAY BACKLIGHT UNIT

FIELD OF THE INVENTION

This invention relates to flat panel display backlight units and in particular to reflectors for direct backlighting units.

Direct backlighting of liquid crystal displays is well known and reflectors for such backlighting units have been developed. For example, U.S. Pat. No. 5,253,151 which issued Oct. 12, 1993 discloses such reflectors.

It is desirable in backlighting units for flat panel displays that the light produced by the backlight unit be uniform and capable of a high intensity over the entire viewing area of the display. In addition, especially for industrial computer displays where failure of the display can result in a costly loss of production, it is desirable that these backlight displays be durable and reliable, and that they do not fail disastrously.

SUMMARY OF THE INVENTION

The invention provides a reflector for multiple parallel cylindrical light sources of the type having an arcuate reflective surface section for each parallel source. Each surface section defines an apex ridge directly behind the corresponding source and the surface section extending from both sides of the apex ridge in arcuate surfaces. An improvement of the invention is that the arcuate surfaces extending from the apex ridge are defined by constant radius surfaces. Thereby, light being transmitted directly rearward from the source is redirected by the constant radius surface to be reflected by another reflector surface back toward the display. The result is to increase the diffusion of the light reflected from the sources, use more of the light to illuminate the display, and reduce the effect of an adjacent lamp dimming or failing completely, all of which contributes to the effectiveness of a reflector of the invention.

In one useful aspect, at least one of the constant radius surfaces is joined at its edge opposite from the apex ridge by a hyperbolic surface. This is desired in areas of the reflector where dispersion and diffusion of the light from the corresponding bulb is desired, such as for the interior surface sections of the reflector. Thereby, when one lamp burns out, light from the adjacent lamps will be reflected into the area of the burned out lamp to fill in for it and largely preserve the visibility of the display until the backlight unit can be replaced.

For interior surface sections, hyperbolic surfaces are preferably provided on both sides of the apex ridge, whereas for the end surface sections, a parabolic surface is preferable provided on the outer side of the apex ridge. The parabolic surface in this location is useful to collimate the light reflected from the corresponding lamp, so as to direct it toward the display and prevent it from escaping past the edge of the display. A further improvement is that a flat reflector surface may be provided outside from each parabolic surface, to direct redirect light toward the display.

BRIEF DESCRIPTION OF THE DRAWINGS

FIG. 1 is a perspective view of a cabinet which incorporates the invention illustrated in an open position;

FIG. 2 is a front plan view of a backlight unit of the invention;

FIG. 3 is a vertical sectional view through the cabinet shown in FIG. 1 illustrated in a closed position;

FIG. 4 is a detail view of a portion of FIG. 3; and

FIG. 5 is a schematic ray tracing of the backlight unit illustrated in FIGS. 1-4.

DETAILED DESCRIPTION OF THE PREFERRED EMBODIMENTS

Referring to FIG. 1, a cabinet 10 incorporating the invention includes a front panel 12 and a cover 14. The cover 14 is secured to the front panel 12 by a hinge 16 secured along corresponding vertical edges of the panel 12 and cover 14 so as to allow pivoting of the cover 14 relative to the panel 12 between the open position shown in FIG. 1 and the closed position shown in FIG. 3.

As best shown in FIGS. 1 and 3, the front panel 12 includes a flat panel display 18 which may be, for example, a thin film transistor (TFT) or metal insulator metal (MIM) type display. However, any flat panel liquid crystal display which is backlit in operation may be used to practice the invention. Preferably, a diffuser plate 19, which may be for example a sheet of white opaque acrylic to diffuse light transmitted against the back of the display 18, directly overlies the back of the display so as to enhance the uniformity of the light transmitted by a backlight unit 22.

The front panel 12 also includes a bezel 20 which frames the display 18 and to which the hinge plate 16A of the hinge 16 is directly connected. Hinge plate 16B of hinge 16 is directly connected to a vertical panel of flange 21 of the cover 14. The cover 14 is made generally in the form of a box so as to house most of the electronic components of the enclosure 10, such as the computer which controls the display 18.

The backlight unit 22 is releasably secured with screws 24 to the front of the cover 14 so that when the cover 14 is pivoted to the open position shown in FIG. 1, the front of the backlight unit 22 is exposed as are the heads of the screws 24. The backlight unit 22 is shown by itself in FIG. 2. When the cover 14 is closed as shown in FIG. 3, the backlight unit 22 is moved to within close proximity of the rear of the display 18 and to being parallel to the display 18 so as to transmit light against the rear of the display 18, through the diffuser plate 19. This provides backlighting to the display 18 which is necessary for a user to view the indicia generated by the display 18. In order to ensure adequate cooling of the display 18, it is preferable to maintain an air gap of $\frac{1}{4}$ to $\frac{3}{8}$ inches between the closest surface of the backlight unit 22 and the rear of the diffuser panel 19 in the closed position.

The backlight unit 22 includes a molded plastic reflector 26 which doubles as the structural foundation to which the other components of the backlight unit 22 are secured. These other components include 6 straight cylindrical cold cathode fluorescent lamps (CCFL's) 28A-F, metal strips 30 and 32 along the respective left and right ends of the lamps 28A-F to hold the lamps in position, a left connector strip 34 for making contact with the left electrodes of the lamps 28A-F and a right connector strip 36 for making an electrical contact with the right electrodes of the lamps 28A-F. Elastomeric material 38 is preferably placed between the strips 30 and 32 and the reflector 26 so as to hold the lamps 28A-F securely in position.

In addition, the right connector strip 36 preferably includes a plug half 40 to mate with a mating plug half 42 which is wired to the electronics in the cover 14 so that the backlight unit 22 may be releasably electrically connected to the enclosure 10. Screws 44 secure the strips 30 and 32 to the reflector 26, and screws 46 secure the connector strips 34

Explore Litigation Insights

Docket Alarm provides insights to develop a more informed litigation strategy and the peace of mind of knowing you're on top of things.

Real-Time Litigation Alerts



Keep your litigation team up-to-date with **real-time alerts** and advanced team management tools built for the enterprise, all while greatly reducing PACER spend.

Our comprehensive service means we can handle Federal, State, and Administrative courts across the country.

Advanced Docket Research



With over 230 million records, Docket Alarm's cloud-native docket research platform finds what other services can't. Coverage includes Federal, State, plus PTAB, TTAB, ITC and NLRB decisions, all in one place.

Identify arguments that have been successful in the past with full text, pinpoint searching. Link to case law cited within any court document via Fastcase.

Analytics At Your Fingertips



Learn what happened the last time a particular judge, opposing counsel or company faced cases similar to yours.

Advanced out-of-the-box PTAB and TTAB analytics are always at your fingertips.

API

Docket Alarm offers a powerful API (application programming interface) to developers that want to integrate case filings into their apps.

LAW FIRMS

Build custom dashboards for your attorneys and clients with live data direct from the court.

Automate many repetitive legal tasks like conflict checks, document management, and marketing.

FINANCIAL INSTITUTIONS

Litigation and bankruptcy checks for companies and debtors.

E-DISCOVERY AND LEGAL VENDORS

Sync your system to PACER to automate legal marketing.