



(19) **United States**

(12) **Patent Application Publication** (10) **Pub. No.: US 2002/0118175 A1**

Liebenow et al.

(43) **Pub. Date: Aug. 29, 2002**

(54) **DIGITAL INFORMATION APPLIANCE
INPUT DEVICE**

Related U.S. Application Data

(75) Inventors: **Frank Liebenow**, Dakota Dunes, SD
(US); **Stephen Vossler**, Sioux Falls, SD
(US)

(62) Division of application No. 09/407,353, filed on Sep. 29, 1999.

Publication Classification

Correspondence Address:
MARK WALKER, ESQ.
GATEWAY, INC.
LAW DEPARTMENT, MSY04
610 GATEWAY DRIVE
N. SIOUX CITY, SD 57049-2000 (US)

(51) **Int. Cl.⁷** **G09G 5/00**
(52) **U.S. Cl.** **345/168**

(57) **ABSTRACT**

A digital information appliance comprises a housing having a display disposed on a first surface for displaying information to a user of the digital information appliance and an input device disposed on a second surface opposed to the first surface for inputting information. The input device is oriented with respect to the display so as to be operable by the fingers of the user's hand for input of information while holding the housing so the display is viewable.

(73) Assignee: **Gateway, Inc.**

(21) Appl. No.: **10/135,113**

(22) Filed: **Apr. 30, 2002**

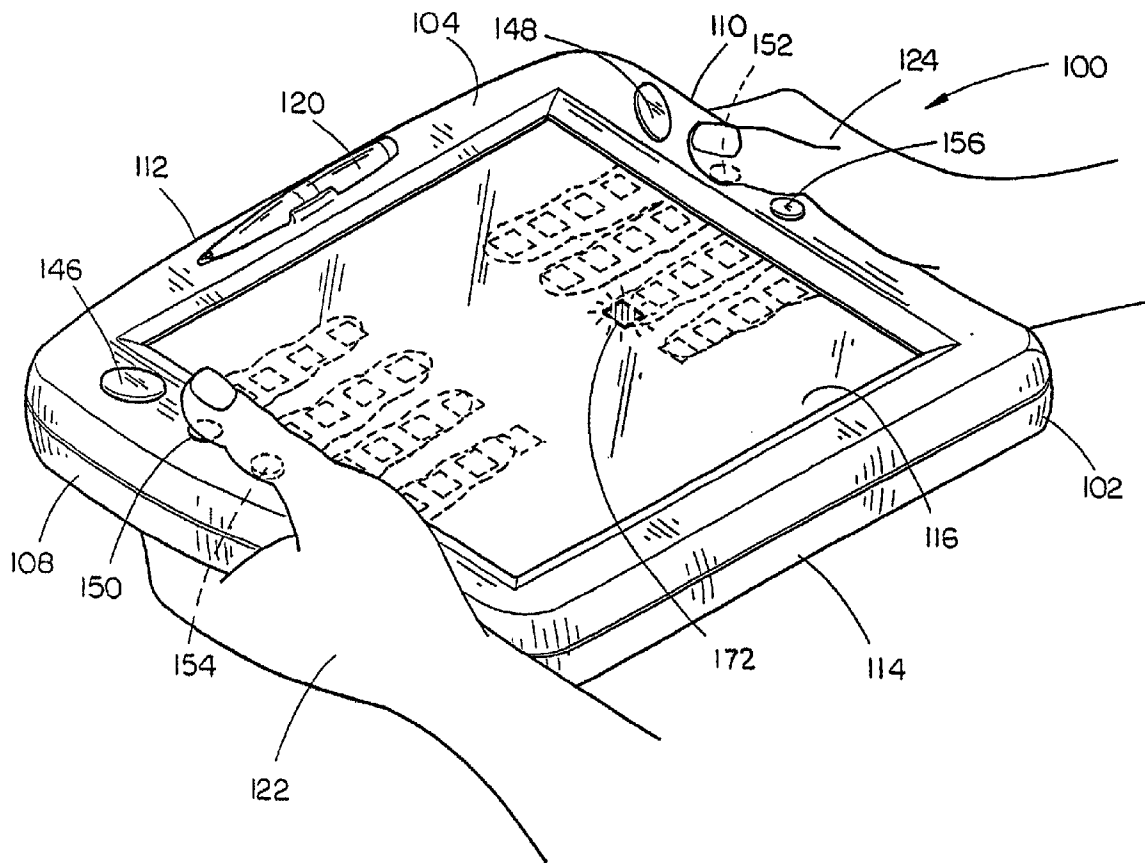

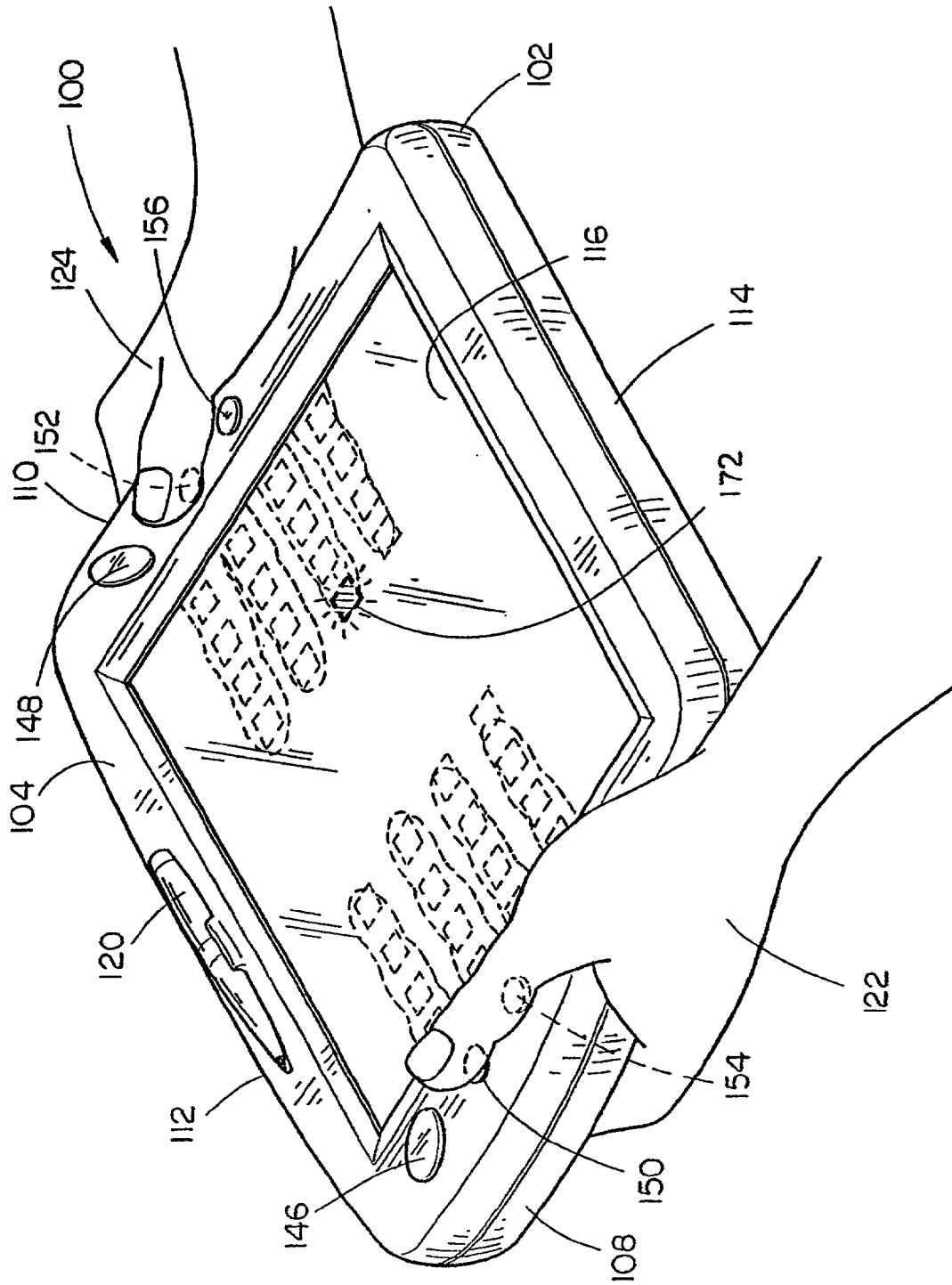
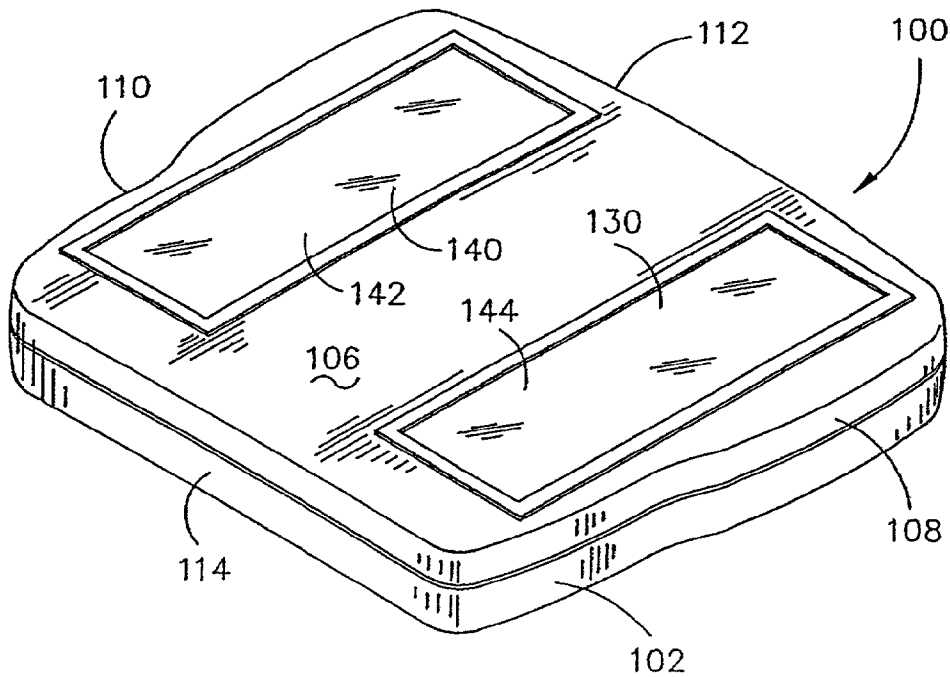
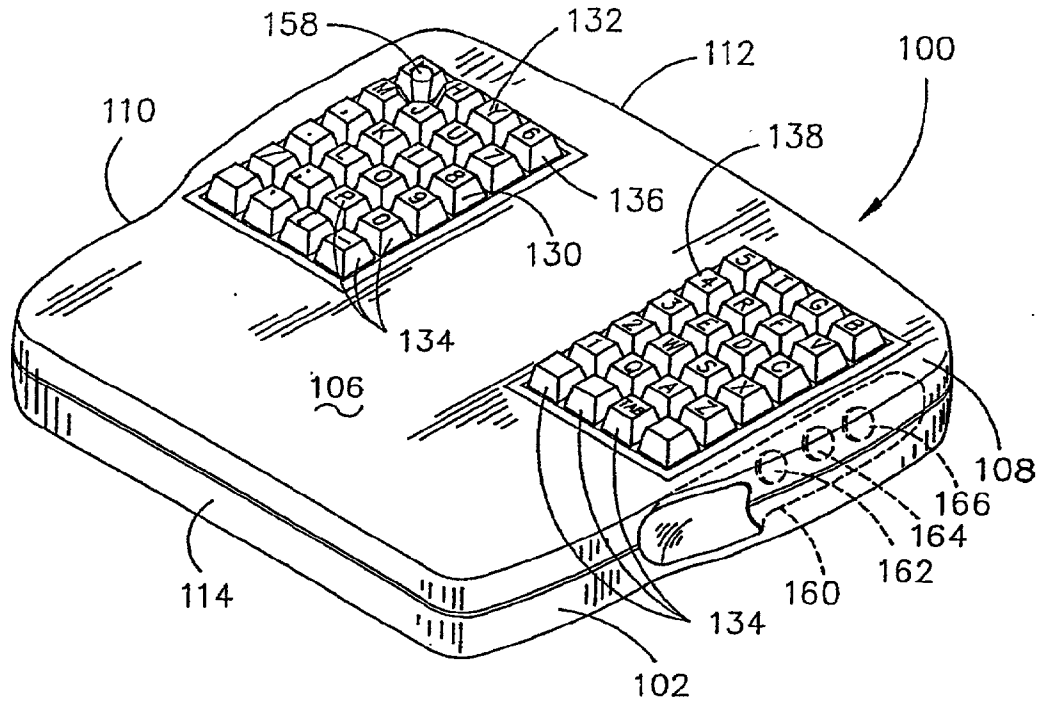

FIG. 1



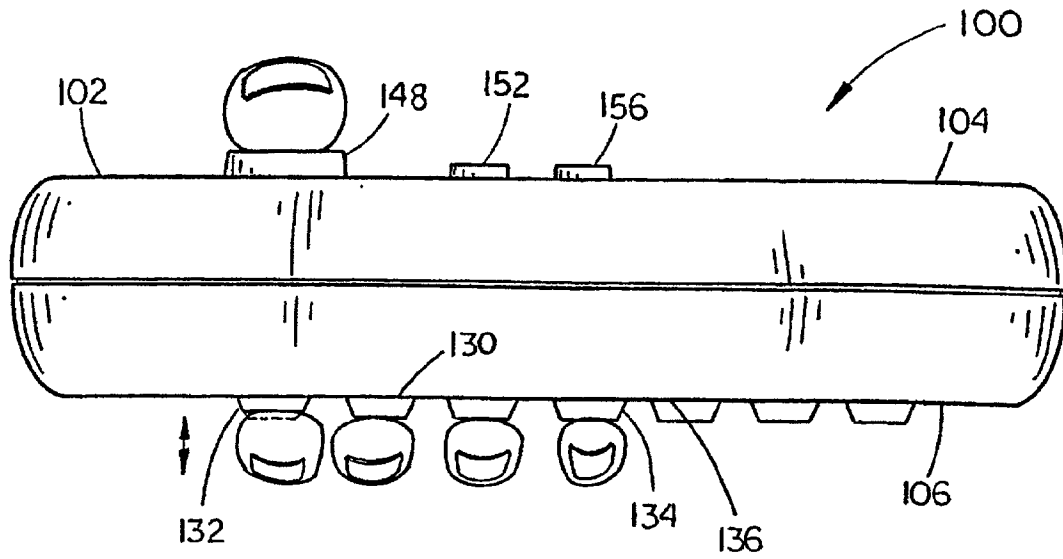

FIG. 3

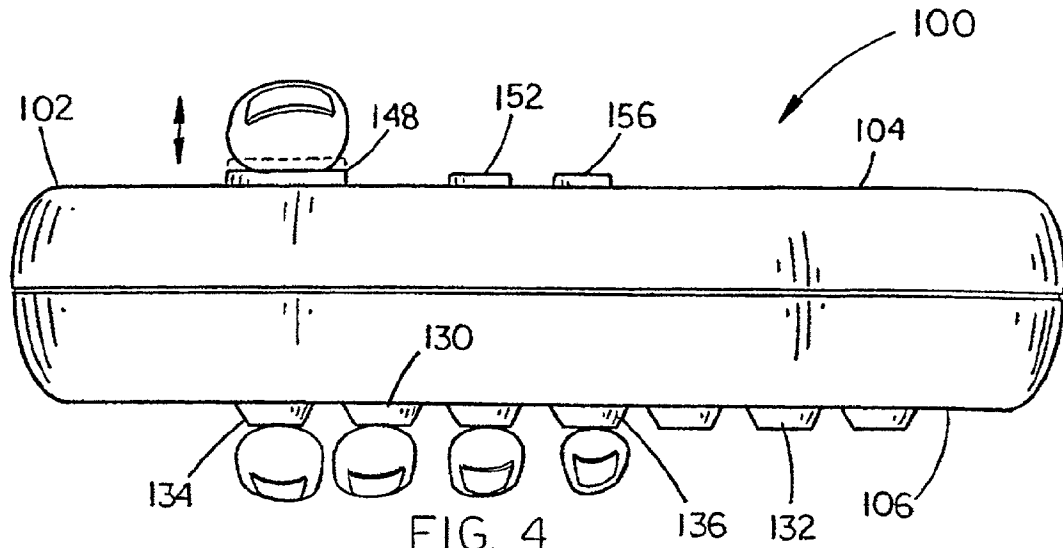

FIG. 4

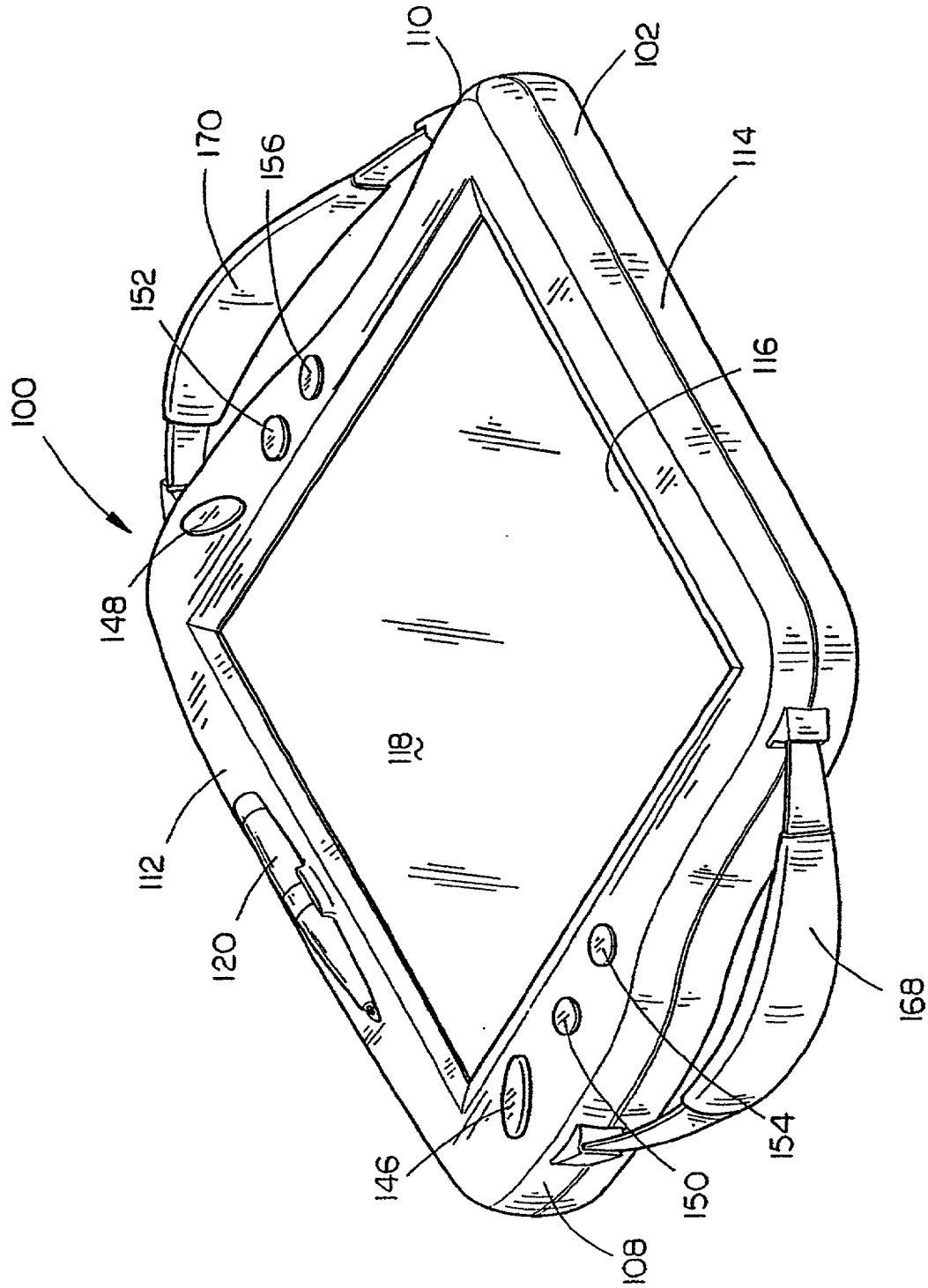

FIG. 6

Explore Litigation Insights

Docket Alarm provides insights to develop a more informed litigation strategy and the peace of mind of knowing you're on top of things.

Real-Time Litigation Alerts



Keep your litigation team up-to-date with **real-time alerts** and advanced team management tools built for the enterprise, all while greatly reducing PACER spend.

Our comprehensive service means we can handle Federal, State, and Administrative courts across the country.

Advanced Docket Research



With over 230 million records, Docket Alarm's cloud-native docket research platform finds what other services can't. Coverage includes Federal, State, plus PTAB, TTAB, ITC and NLRB decisions, all in one place.

Identify arguments that have been successful in the past with full text, pinpoint searching. Link to case law cited within any court document via Fastcase.

Analytics At Your Fingertips



Learn what happened the last time a particular judge, opposing counsel or company faced cases similar to yours.

Advanced out-of-the-box PTAB and TTAB analytics are always at your fingertips.

API

Docket Alarm offers a powerful API (application programming interface) to developers that want to integrate case filings into their apps.

LAW FIRMS

Build custom dashboards for your attorneys and clients with live data direct from the court.

Automate many repetitive legal tasks like conflict checks, document management, and marketing.

FINANCIAL INSTITUTIONS

Litigation and bankruptcy checks for companies and debtors.

E-DISCOVERY AND LEGAL VENDORS

Sync your system to PACER to automate legal marketing.