

UNITED STATES PATENT AND TRADEMARK OFFICE

---

BEFORE THE PATENT TRIAL AND APPEAL BOARD

---

TRW AUTOMOTIVE U.S. LLC,  
Petitioner,

v.

MAGNA ELECTRONICS INC.,  
Patent Owner.

---

Cases IPR2015-00436, IPR2015-00437,  
IPR2015-00438, and IPR2015-00439  
Patent 8,599,001 B2

---

Before JUSTIN T. ARBES, BART A. GERSTENBLITH, and  
FRANCES L. IPPOLITO, *Administrative Patent Judges*.

ARBES, *Administrative Patent Judge*.

DECISION  
Institution of *Inter Partes* Review  
37 C.F.R. § 42.108

Petitioner, TRW Automotive U.S. LLC, filed four Petitions requesting *inter partes* review of claims 1–24, 28, 32, 34–40, 42–69, 71, and 73–109 of U.S. Patent No. 8,599,001 B2 (Ex. 1001, “the ’001 patent”)<sup>1</sup> pursuant to 35 U.S.C. §§ 311–19. Patent Owner, Magna Electronics Inc., filed a Preliminary Response in each proceeding, as listed in the following chart.

Case Number	Challenged Claims	Petition	Preliminary Response
IPR2015-00436	1–10, 15–23, 28, 32, 34–40, and 42–55	Paper 3 (“Pet.”)	Paper 9 (“Prelim. Resp.”)
IPR2015-00437	24, 56–69, 71, and 73–78	Paper 3 (“-437 Pet.”)	Paper 9 (“-437 Prelim. Resp.”)
IPR2015-00438	79–95	Paper 4 (“-438 Pet.”)	Paper 9 (“-438 Prelim. Resp.”)
IPR2015-00439	11–14 and 96–109	Paper 2 (“-439 Pet.”)	Paper 9 (“-439 Prelim. Resp.”)

We have jurisdiction under 35 U.S.C. § 314. Pursuant to 35 U.S.C. § 314(a), the Director may not authorize an *inter partes* review unless the information in the petition and preliminary response “shows that there is a reasonable likelihood that the petitioner would prevail with respect to at least 1 of the claims challenged in the petition.” For the reasons that follow, we institute an *inter partes* review as to claims 1–15, 24, 28, 32, 34–40, 42–50, 53–66, 69, 71, 73–79, 81–85, 87–100, and 102–08 of the ’001 patent on certain grounds of unpatentability. To administer the proceedings more

---

<sup>1</sup> Petitioner filed its exhibits in the following series: Exhibits 1001–11 (Case IPR2015-00436), Exhibits 1101–11 (Case IPR2015-00437), Exhibits 1201–11 (Case IPR2015-00438), and Exhibits 1301–11 (Case IPR2015-00439). References herein to each of Petitioner’s exhibits are to the exhibit filed in the corresponding proceeding.

efficiently, we also exercise our authority under 35 U.S.C. § 315(d) to consolidate the four proceedings and conduct the proceedings as one trial.

## I. BACKGROUND

### A. The '001 Patent

The '001 patent describes a “vehicle lighting control system for controlling a vehicle lighting system in an automotive vehicle comprising a photosensor array means for sensing light levels in a forward field of view” of the vehicle. Ex. 1002, col. 6, l. 61–col. 7, l. 2. The disclosed system is integrated with the rearview mirror of the vehicle and “directed generally forward of the vehicle so that it may sense a field of view forward of the rearview mirror” through the vehicle’s front windshield. *Id.* at col. 33, ll. 7–17. Figure 6B of the '001 patent is reproduced below.

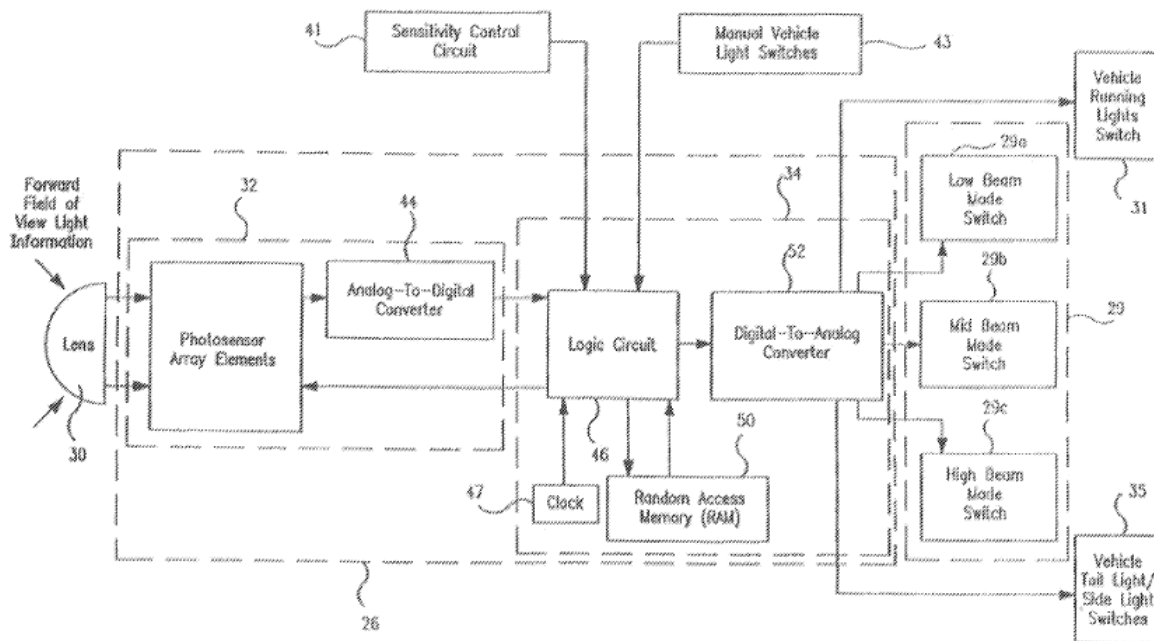

FIG. 6B

Figure 1 depicts lens 30, photosensor array 32, logic and control circuit 34, and headlight switches 29. *Id.* at col. 33, ll. 7–46. Logic and control

circuit 34 receives image data from photosensor array 32, processes the data to “determine and identify whether there are other headlights and taillights in the driver’s forward field of view,” and uses that determination to “control automatically the vehicle headlights” via low beam mode switch 29a, mid beam mode switch 29b, and high beam mode switch 29c. *Id.* at col. 33, ll. 31–67.

### *B. Illustrative Claim*

Claim 1 of the ’001 patent recites:

1. A vehicular vision system, said vehicular vision system comprising:

an imager comprising a lens and a CMOS photosensor array;

wherein said photosensor array comprises a plurality of photosensor elements;

wherein said imager is disposed at an interior portion of a vehicle equipped with said vehicular vision system and wherein said imager views exterior of the equipped vehicle through a windshield of the equipped vehicle and forward of the equipped vehicle;

wherein at least said imager is disposed in a module attached at the windshield of the equipped vehicle;

a control comprising an image processor, said image processor processing image data captured by said photosensor array;

wherein said image processor processes captured image data to detect an object viewed by said imager;

wherein said photosensor array is operable at a plurality of exposure periods; and

wherein said plurality of exposure periods comprises a first exposure period and a second exposure period, and wherein the time period of exposure of said first exposure

period is longer than the time period of exposure of said second exposure period.

### *C. The Prior Art*

Petitioner relies on the following prior art:

U.S. Patent No. 4,930,742, issued June 5, 1990 (Ex. 1108, “Schofield”);

U.S. Patent No. 4,970,653, issued Nov. 13, 1990 (Ex. 1005, “Kenue”);

U.S. Patent No. 5,166,681, issued Nov. 24, 1992 (Ex. 1010, “Bottesch”);

Japanese Unexamined Patent Publication No. S62-131837, published June 15, 1987 (Ex. 1006, “Yanagawa”);<sup>2</sup>

European Patent Application Publication No. 0353200 A2, published Jan. 31, 1990 (Ex. 1107, “Venturello”);

International Patent Application Publication No. WO 93/11631, published June 10, 1993 (Ex. 1009, “Denyer”); and

Oliver Vellacott, *CMOS in camera*, IEE REV., May 1994, at 111 (Ex. 1004, “Vellacott”).<sup>3</sup>

### *D. The Asserted Grounds*

Petitioner challenges claims 1–24, 28, 32, 34–40, 42–69, 71, and 73–109 of the ’001 patent as unpatentable under 35 U.S.C. § 103(a) on the following grounds:

---

<sup>2</sup> We refer to “Yanagawa” as the English translation of the original reference. Petitioner provided an affidavit attesting to the accuracy of the translation. *See* Ex. 1006; 37 C.F.R. § 42.63(b).

<sup>3</sup> When citing Yanagawa and Vellacott, we refer to the page numbers at the lower right corner of each page. *See* 37 C.F.R. § 42.63(d)(2).

# Explore Litigation Insights

Docket Alarm provides insights to develop a more informed litigation strategy and the peace of mind of knowing you're on top of things.

## Real-Time Litigation Alerts



Keep your litigation team up-to-date with **real-time alerts** and advanced team management tools built for the enterprise, all while greatly reducing PACER spend.

Our comprehensive service means we can handle Federal, State, and Administrative courts across the country.

## Advanced Docket Research



With over 230 million records, Docket Alarm's cloud-native docket research platform finds what other services can't. Coverage includes Federal, State, plus PTAB, TTAB, ITC and NLRB decisions, all in one place.

Identify arguments that have been successful in the past with full text, pinpoint searching. Link to case law cited within any court document via Fastcase.

## Analytics At Your Fingertips



Learn what happened the last time a particular judge, opposing counsel or company faced cases similar to yours.

Advanced out-of-the-box PTAB and TTAB analytics are always at your fingertips.

## API

Docket Alarm offers a powerful API (application programming interface) to developers that want to integrate case filings into their apps.

## LAW FIRMS

Build custom dashboards for your attorneys and clients with live data direct from the court.

Automate many repetitive legal tasks like conflict checks, document management, and marketing.

## FINANCIAL INSTITUTIONS

Litigation and bankruptcy checks for companies and debtors.

## E-DISCOVERY AND LEGAL VENDORS

Sync your system to PACER to automate legal marketing.