

EXHIBIT 1064

J. dela TORRE, Jr., “Earth Reference Imager Experiment for Satellite Attitude
Determination,” Arizona State University (1995)

TRW Automotive U.S. LLC: EXHIBIT 1064
PETITION FOR *INTER PARTES* REVIEW
OF U.S. PATENT NUMBER 8,599,001
IPR2015-00436

Earth Reference Imager Experiment for Satellite Attitude Determination

Student Author: Jose' L. delaTorre, Jr.¹
Faculty Advisors: Dr. Jordi Puig-Suari² and Dr. Helen L. Reed³
Arizona State University
Tempe, Arizona 85287-8006

Abstract

The Earth Reference Imager (ERI) experiment on board the ASUSat 1 student satellite will provide valuable attitude information to validate the new attitude sensors along with the GPS data. Using the concept of triangulation, the satellite's tilt, swing, height, azimuth, and coordinates will be attained from an image of the Earth. This information will then be compared with the attitude sensors to confirm the data received from the satellite.

Nomenclature

A, B, C	ground control points
a, b, c	image ground control points
f	focal length
H	altitude of satellite
h_A, h_B, h_C	elevation at point
L_o	distance from nodal point of lens to place of photograph
L	space position of front nodal point
N	ground nadir point
n	nadir point
o	principal point
R_G	ratio between AB and AC on the ground
R_V	ratio between AB and AC on a vertical photograph
S_G	ratio between AB and BC on the ground
S_V	ratio between AB and AC on a vertical photograph
s	swing of photograph
t^*	introduced tilt of arbitrary amount
X_L, Y_L, Z_L	space coordinates of exposure station
(x, y)	photographic coordinates of image
x', y'	ground coordinates with arbitrary tilt calculated about the y axis
x'', y''	ground coordinates with arbitrary tilt calculate about the x axis
α_G	ground survey azimuth
α_{no}	azimuth of principal plane
α_p	azimuth of control line
θ	amount of rotation

¹Junior, Mathematics, ASUSat 1 Science Team

²Assistant Professor, Mechanical & Aerospace Engineering; AIAA Member

³Director, Aerospace Research Center; Associate Director, ASU NASA Space Grant Program

1. Introduction

1.1 ASUSat 1

Since its inception, Arizona State University's first small satellite, ASUSat 1, has been a student-designed project. Many members of local industry and the faculty of ASU have been very supportive of the project, and have sponsored and advised several aspects of the program.

Weighing ten pounds (4.5 kg), the satellite will be the lightest ever put into orbit with meaningful science experiments¹. The payload will be launched by Orbital Sciences Corporation on a Pegasus launch vehicle and will be placed at a 325-km sun-synchronous orbit. It is expected to remain in orbit for approximately 22 days.

ASUSat 1 will allow researchers to measure the properties of the ionosphere at a low cost. Furthermore, it will provide an audio transponder for amateur radio operators.

There have been an average of forty students ranging from high-school through Ph.D level working in ten different sub-systems. These are science, structures & materials, dynamics & controls, communications, power, thermal, commands, ground support equipment (GSE), software & data analysis, and systems integration.

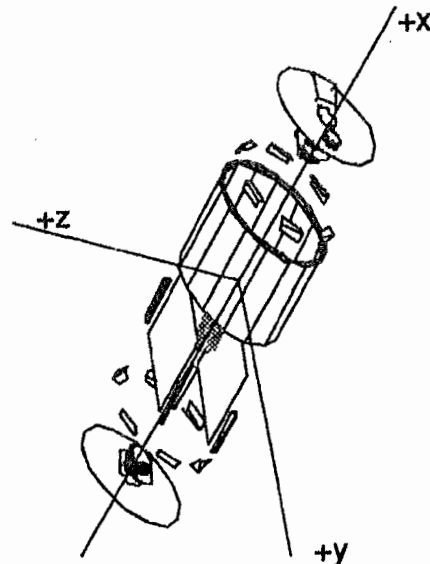

The science team is developing a Hall-Current Ion Accelerator, a Magnetohydrodynamic Generator, Ion Thrusters, and the Earth Reference Imager.

The structures team designed a fourteen-sided graphite / epoxy bus and overlooks cabling and mounting on the satellite.

Dynamics is providing stabilization with an aerodynamic boom and a fluid damper. Moreover, they are providing positioning information through a GPS receiver and an array of photodiodes.

Communications has student-built the modem and designed a deployable antenna.

The power sub-system will be providing power to the satellite through two six-packs of Sanyo NiCd batteries, re-charged with GaAs solar cells around the fourteen sides of the bus. The satellite will be powered up with a mechanical switch when the satellite is deployed.

The thermal team keeps track of the temperatures inside the bus, and stabilizes them with paints and highly emissive coatings. The temperatures expected outside the satellite are in the range of -24°C to 90°C .

Commands is designing the processor around the INTEL 80C188EC chip, running it at 10 MHz. Two I/O ports provide interfaces with the science/dynamics board and with the camera interface board. There is also an Error Detection and Correction (EDAC) facility built in for the 1 Mbyte of RAM available for the satellite's data. One EPROM will be used for the default operating system, while another will contain the bootloader for the satellite's system.

Ground support is providing the testing equipment and facilities. Orbital Sciences has allowed the ASUSat 1 team to use several of its facilities.

The software for ASUSat 1 is being written in C and compiled to run in the BekTek Real-time Spacecraft Operating System designed for micro-satellites.

Finally, the systems and integration team is coordinating all the designing, integration, testing and documentation of all the sub-systems of the satellite.

The pointing requirements have been defined to be $\pm 10^{\circ}$, with orbital positioning being within $\pm 1\text{ km}^1$ to attain full coverage of the Earth. It is hoped that the drag coefficient can be calculated. To achieve these goals, a new attitude-sensors array has been designed and developed to give the satellite's orientation.

The coordinate axis is defined as shown in figure 1. The x axis lies along the axis of symmetry, y axis runs parallel to the inside panels and perpendicular to the x axis, and the z axis runs perpendicular to the panels, through the center.

1.2 Earth and Sun Sensors

To keep control of the satellite, its orientation information will be recorded through a complex network of photo sensors. With a total of sixty of these photodiodes positioned around the satellite, there will be almost complete coverage of the sky. Of the sixty sensors, forty-six will be sun sensors which will be keyed in to visible light, and the remaining fourteen will be Earth sensors, filtered to receive in the infra-red.²

There will be blocks of three sun sensors on each of the fourteen sides of the satellite, one being normal to the surface of the side, and the other two at $\pm 45^{\circ}$ from the normal. Earth sensors will be positioned on every other side of the satellite, and the remaining sensors will be placed on the front and back plates of the satellite.²

The sensors themselves are Motorola Photo Detectors, MRD510, with filters being placed on the Earth sensors. These diodes will produce voltages ranging from 0-5 V, proportional to the amount of light received. The readings from each sensor will be recorded every five minutes, and the data will later be processed on the ground.²

However, this dynamics sensor array has never been flown, and other data is necessary to confirm the accuracy of the data from the satellite's sensors. To confirm the information received from the sensors, a camera will be flown to image the Earth vertically. Then, by performing the methods of triangulation on the ground images from the satellite, it is hoped to confirm the positioning data given by the sensors array. To ensure that the camera is perpendicular to the Earth, the sensors will be used to approximate where the Earth is relative to the satellite.

1.3 GPS

The Global Positioning System (GPS) was developed primarily for military purposes by the Department of Defense. However, the technology has become available to the public.

Consisting of a global network of twenty-four satellites at high altitudes, GPS provides its users with accurate position and velocity data. GPS receivers have been used on Lower Earth Orbit satellites in the past for determining the satellite's orbital parameters.³ By a method of triangulation, the satellites are able to practically pinpoint the receiver's position.

Several factors have introduced errors in the GPS measurements such as the ionosphere which causes some interference. On the average, GPS may be off by about sixty feet, and in the worst case, GPS data may be off by as much as 350 ft. ³

ASUSat 1 will carry a Trimble GPS receiver on board. The SVee Six-CM2 is a terrestrial board with 6 channels and has never been flown in space before, but it has been rigorously tested by ASU students to ensure that it will survive in space.^{4,5} The accuracy of this particular unit is 25m. Readings will periodically be measured and recorded from the GPS to determine the satellite's position and velocity.⁴

From the GPS data included in the telemetry, it will be known from where the images were taken. This will prove useful in identifying the precise location of the image, and in verifying the position calculations from the images.

1.4 Earth Reference Imager

Once the images have been received and processed on the ground, it will be possible to perform several measurements on the images, and do calculations on them with a certain degree of error. The error will depend on the resolution of the image and on the scale of the photograph.

From the image, three points will have to be identified, the distances between each of them calculated, and the elevations from sea level of each point attained to perform the desired calculations⁶.

2 Earth Reference Imager

2.1 Imager

The cameras being used for the experiments on ASUSat 1 are single-chip CMOS digital cameras. The cameras, VVL-1070, have a pixel resolution of 160 x 160 pixels, and put out 8-bit digital parallel output. The pixel size is 10.5 μm x 10.5 μm , giving a total effective array size of 1.68 mm x 1.68 mm. The camera also provides analog output, and an exposure control (2,000:1), gain control, and variable frame rate (0.5 - 24 frames/sec). At 5V, the chip consumes less than 100 mW.

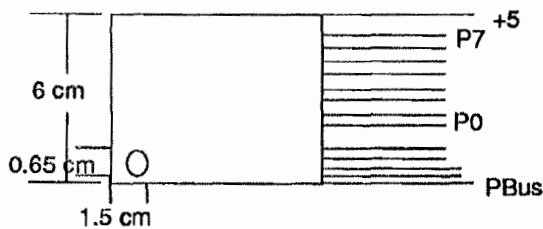

Figure 2 Dimensions and basic layout of camera board. There are five control lines and eight data lines on each board. The lens is mounted in the corner.

2.2 Optics

The lenses being used for the cameras are V-4308 multi-element lens with a diameter of 15 mm across the top and focal length of 8mm with an f-stop of 2.0. The lens weighs about 7 grams. The field of view given in the specifications is 31° x 23° (H x V).⁷ Assuming the satellite is at a 325 km orbit and that the camera is facing vertically down to Earth, the range of the image would be 195.3km x 138km,⁸ giving a resolution of about 1 km per pixel (Fig. 3). Furthermore, the scale is calculated as the focal length over the altitude of the camera, which is approximately 1: 40,625,000 in this case.⁷ By keeping the field of view and ground coverage limited, the resolution should be optimized for the digital camera chips.

2.3 Placement

The lens will be fixed over the camera on the camera board using a lens holder, with the appropriate focal length to focus the image. The board will measure approximately 4 cm x 6 cm (Fig. 2), allowing the camera to be placed along the side of one of the satellite's side panels. A hole of 0.65 cm in diameter will be drilled to allow the lens to be mounted up to it to view the Earth at a right angle to the satellite's axis of symmetry (Fig. 4) close to the z axis (Fig. 1).

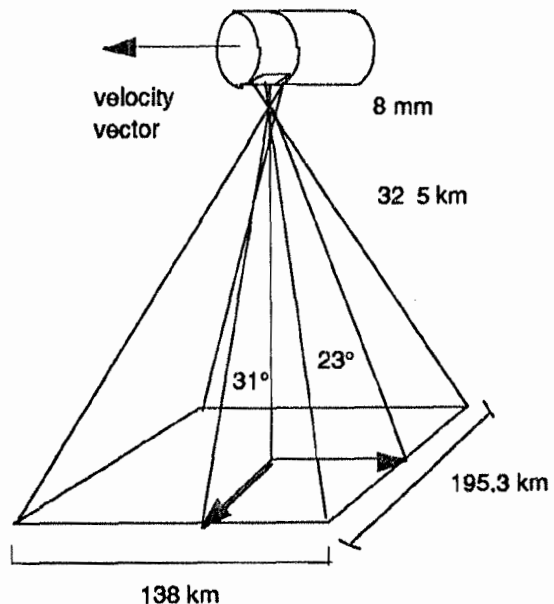

Figure 3 With a field of view of 31°-23°, altitude of 325 km, and focal length of 8 mm, the ground coverage should be about 138 km x 195.3 km.

2.4 Protection

The circuitry for the camera board will be surface mounted and conformal coated to protect from vibration and shock. Dampers will be placed around the board and lens as well. A gold foil will be put around the outside camera board to reflect the sun's radiation, to keep it cool, and to protect the circuitry from cosmic particle hits.

3 Camera Boards

The VVL-1070 chip has a built-in analog-to-digital converter (A/D) circuit, so the output is already digital.⁹ The supporting electronics, then, drive the camera at real-time clock speeds, and transfer the images to the main CPU bus through a 25-pin interface.

ASUSat 1 will carry two CMOS cameras, one for determining the satellite's roll rate, and the other for the ERI experiment. Both will have the supporting circuit board (Fig. 2). The boards consist of their own microprocessors and memory with built-in commands to run the camera. Running at real time rates, the image will be dumped into the local memory, where the main CPU can then read the memory at its own rate and store it to be downloaded at a later time.¹⁰ There will also be an interface board between the two camera boards and the main CPU which handles the control of the two cameras from a chip select in the interface. The interface consists of five control lines for each camera, and eight data lines which will be shared by both cameras (Fig. 5). The camera boards will be designed by Gordon Minns & Associates in Wyoming.

The software to control all three microprocessors will be written in ANSI C and will be compiled for a BekTek operating system.¹¹ The

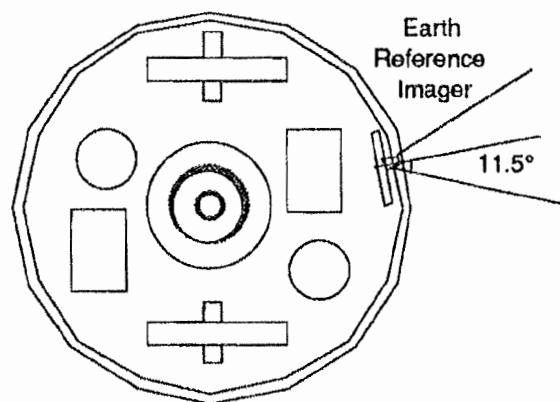

Figure 4 The ERI camera will be mounted to one of the 14 side panels of the satellite to view the Earth vertically with a range of 23°.

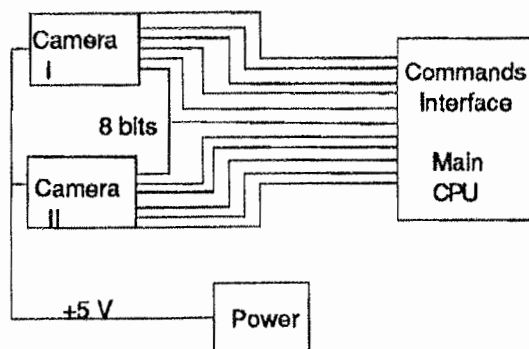

Figure 5 The two cameras on ASUSat 1 will go to a camera interface board which will connect to the main processor's control interface. The 8-bit data lines will be shared by both cameras.

supporting software will be included with the camera-board product to be modified by the software team. The commands will be uploaded to the satellite, where the cameras will be allotted ten minutes per orbit to take images.¹² The camera boards will consume less than 100 mW as well, and the size of each image will be about 25 kB. At this size, it will be possible to take about ten consecutive images in one orbit.¹⁰

4 Image Processing

Once the images have been taken, and transferred to the main CPU bus, the data will be downloaded to the ground station at Arizona State University several times a day. When the images have been successfully transferred, they will be moved over the internet to a Silicon Graphics machine for image processing. Using an image processing package such as XV, several analyses will be done on the images such as filterings, histograms, and averaging.¹³ Software such as IDL is also available along with faculty experienced in professional image processing.

Once the images have been optimized, whether taking the average of consecutive frames or filtering high frequencies, the image will be ready for the data analysis.⁸ From the image, it will be crucial to identify the objects and locations on Earth, or in the sky, for determining the satellite's attitude. This can be done by comparing daily weather maps, terrain maps, and GPS data along with the dynamics-sensors data to approximate the location at which the image was taken.² Weather maps will reveal cloud covers where an image may be completely white, in which case the image data will not be very helpful. Otherwise, the image can then be used to perform the triangulation.

Explore Litigation Insights

Docket Alarm provides insights to develop a more informed litigation strategy and the peace of mind of knowing you're on top of things.

Real-Time Litigation Alerts



Keep your litigation team up-to-date with **real-time alerts** and advanced team management tools built for the enterprise, all while greatly reducing PACER spend.

Our comprehensive service means we can handle Federal, State, and Administrative courts across the country.

Advanced Docket Research



With over 230 million records, Docket Alarm's cloud-native docket research platform finds what other services can't. Coverage includes Federal, State, plus PTAB, TTAB, ITC and NLRB decisions, all in one place.

Identify arguments that have been successful in the past with full text, pinpoint searching. Link to case law cited within any court document via Fastcase.

Analytics At Your Fingertips



Learn what happened the last time a particular judge, opposing counsel or company faced cases similar to yours.

Advanced out-of-the-box PTAB and TTAB analytics are always at your fingertips.

API

Docket Alarm offers a powerful API (application programming interface) to developers that want to integrate case filings into their apps.

LAW FIRMS

Build custom dashboards for your attorneys and clients with live data direct from the court.

Automate many repetitive legal tasks like conflict checks, document management, and marketing.

FINANCIAL INSTITUTIONS

Litigation and bankruptcy checks for companies and debtors.

E-DISCOVERY AND LEGAL VENDORS

Sync your system to PACER to automate legal marketing.