

UNITED STATES PATENT AND TRADEMARK OFFICE

---

BEFORE THE PATENT TRIAL AND APPEAL BOARD

---

IRON DOME LLC  
Petitioner

v.

E-WATCH, INC.  
Patent Owner

---

Case IPR2014-00439  
Patent 7,365,871

---

Before JAMESON LEE, GREGG I. ANDERSON, and  
MATTHEW R. CLEMENTS, *Administrative Patent Judges*.

CLEMENTS, *Administrative Patent Judge*.

DECISION  
Institution of *Inter Partes* Review  
37 C.F.R. § 42.108

## I. INTRODUCTION

Iron Dome LLC (“Petitioner”) filed a Petition requesting *inter partes* review of claims 1-15 (“the challenged claims”) of U.S. Patent No. 7,365,871 (Ex. 1001, “the ’871 patent”). Paper 1 (“Pet.”). e-Watch, Inc. (“Patent Owner”) filed a Preliminary Response. Paper 9 (“Prelim. Resp.”). We have jurisdiction under 35 U.S.C. § 314, which provides that an *inter partes* review may only be authorized if “the information presented in the petition . . . and any [preliminary] response . . . shows that there is a reasonable likelihood that the petitioner would prevail with respect to at least 1 of the claims challenged in the petition.” 35 U.S.C. § 314(a). Upon consideration of the Petition and Preliminary Response, we determine that the information presented by Petitioner establishes that there is a reasonable likelihood that Petitioner would prevail in showing the unpatentability of only claims 1 and 3 of the ’871 patent. Accordingly, pursuant to 35 U.S.C. § 314, we institute an *inter partes* review of claims 1 and 3 of the ’871 patent.

### A. Related Proceedings

Petitioner and Patent Owner indicate that the ’871 patent is involved in eleven co-pending district court cases in the U.S. District Court for the Eastern District of Texas. Pet. 2; Paper 7, 3.

### B. The ’871 Patent

The ’871 patent relates generally to image capture and transmission systems, and is directed specifically to an image capture, compression, and transmission system for use in connection with landline and wireless telephone systems. Ex. 1001, 1:17-20. According to the ’871 patent, the

system is particularly well-suited for sending and/or receiving images via a standard Group III facsimile transmission system and permits capture of the image at a remote location using an analog or digital camera. *Id.* at 5:3-7.

Figure 1 of the '871 patent is reproduced below.

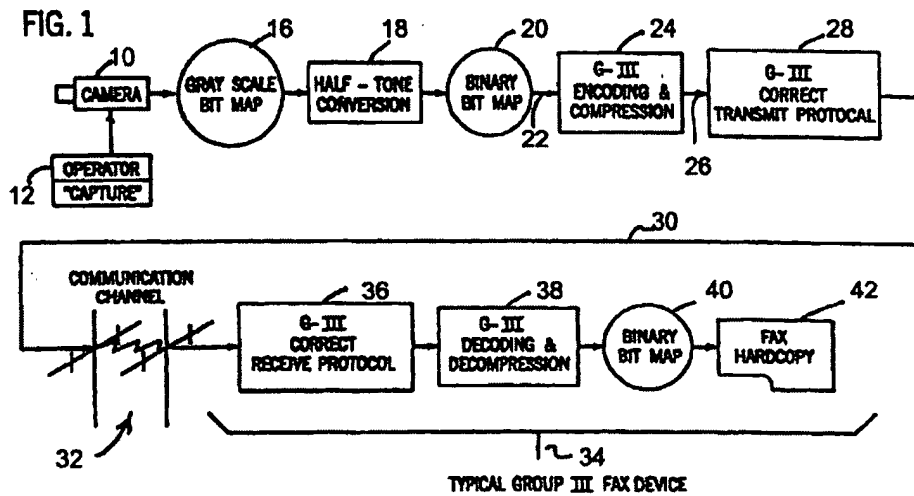

“Figure 1 is a block diagram of a basic facsimile camera configuration for capturing an image via a camera and transmitting it via Group III facsimile transmission to a standard hard copy medium.” *Id.* at 4:27-30.

Figure 7A of the '871 patent is reproduced below.

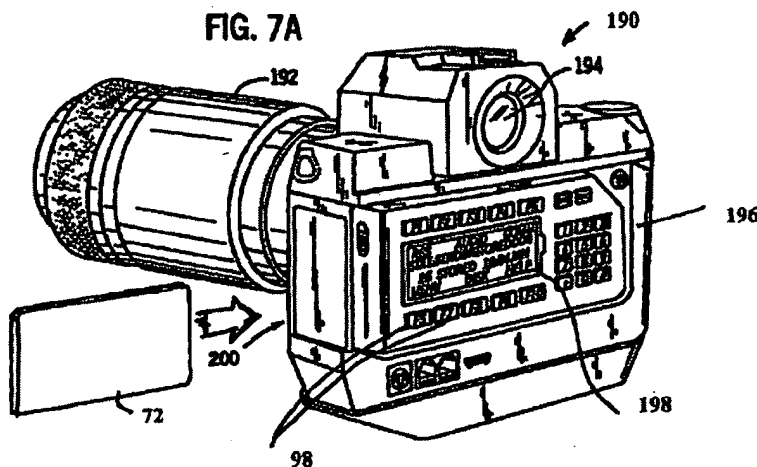

Figure 7A depicts a “hand-held device for capturing, storing, and transmitting an image in accordance with the invention.” *Id.* at 4:46-48, 11:3-20.

*C. Illustrative Claim*

Of the challenged claims, claims 1, 6, 9, and 12 are independent.

Claim 1 is reproduced below:

1. A handheld self-contained cellular telephone and integrated image processing system for both sending and receiving telephonic audio signals and for capturing a visual image and transmitting it to a compatible remote receiving station of a wireless telephone network, the system comprising:
  - a manually portable housing;
  - an integral image capture device comprising an electronic camera contained within the portable housing;
  - a display for displaying an image framed by the camera, the display being supported by the housing, the display and the electronic camera being commonly movable in the housing when the housing is moved by hand;
  - a processor in the housing for generating an image data signal representing the image framed by the camera;
  - a memory associated with the processor for receiving and storing the digitized framed image, accessible for selectively displaying in the display window and accessible for selectively transmitting over the wireless telephone network the digitized framed image;
  - a user interface for enabling a user to select the image data signal for viewing and transmission;
  - a telephonic system in the housing for sending and receiving digitized audio signals and for sending the image data signal;
  - alphanumeric input keys in the housing for permitting manually input digitized alphanumeric signals to be input to the

processor, the telephonic system further used for sending the digitized alphanumeric signals;

a wireless communications device adapted for transmitting any of the digitized signals to the compatible remote receiving station; and

a power supply for powering the system.

*D. References Relied Upon*

Petitioner relies upon the following references:

|          |              |                |          |
|----------|--------------|----------------|----------|
| Parulski | US 6,122,526 | Sept. 19, 2000 | Ex. 1002 |
| Reele    | US 5,893,037 | April 6, 1999  | Ex. 1003 |

*E. The Asserted Grounds of Unpatentability*

Petitioner argues that the challenged claims are unpatentable as obvious over Parulski and Reele.

II. ANALYSIS

*A. Status of Parulski and Reele as Prior Art*

As an initial matter, we review whether the references relied upon by Petitioner qualify as prior art. Parulski has an effective filing date of April 24, 1995. Reele has an effective filing date of December 9, 1994. Both Parulski and Reele qualify as prior art under 35 U.S.C. §§ 102(a) and 102(e), because neither was issued or published more than one year prior to the effective filing date of the '871 patent, but the effective filing date of each is earlier than the effective filing date of the '871 patent (January 12, 1998). Patent Owner argues that Parulski cannot be prior art in this proceeding, because U.S. Patent No. 5,666,159 to Parulski ("Parulski '159"), which has the same specification and priority date as Parulski, was determined during prosecution to be antedated and the affidavit submitted during prosecution,

therefore, overcomes all §102(a) and §102(e) prior art having an effective date of April 24, 1995 or later. Prelim. Resp. 3-10 (citing Exs. 2001-2002 (Affidavit of David A. Monroe Under 37 CFR 1.131) (“2004 Monroe Declaration”); Ex. 2003 (Office Action dated August 9, 2005)). Patent Owner is correct that the Examiner determined during prosecution that the 2004 Monroe Declaration sufficiently antedated Parulski ’159. Ex. 2003, 2. We are not, however, bound by that determination. We have reviewed the 2004 Monroe Declaration and the prosecution record, and, on the record before us at this time, we find Patent Owner’s arguments that Parulski is sufficiently antedated by the 2004 Monroe Declaration to be unpersuasive for the reasons discussed below.

Priority of invention goes to the first party to reduce to practice unless the other party can show that it was the first to conceive the invention and that it exercised reasonable diligence in later reducing that invention to practice. *Brown v. Barbacid*, 276 F.3d 1327, 1337 (Fed. Cir. 2002); *Cooper v. Goldfarb*, 154 F.3d 1321, 1327 (Fed. Cir. 1998); *Mahurkar v. C.R. Bard, Inc.*, 79 F.3d 1572, 1577 (Fed. Cir. 1996). An inventor’s testimony, standing alone, is insufficient to prove conception, as some form of corroboration is required. *Mahurkar*, 79 F.3d at 1577; *Price v. Symsek*, 988 F.2d 1187, 1194 (Fed. Cir. 1993). A rule of reason applies to determine whether the inventor’s testimony has been corroborated. *Price*, 988 F.2d at 1194.

During the period in which reasonable diligence must be shown, there must be continuous exercise of reasonable diligence. *In re McIntosh*, 230 F.2d 615, 619 (CCPA 1956); *see also Burns v. Curtis*, 172 F.2d 588, 591 (CCPA 1949) (referring to “reasonably continuous activity”). A party

alleging diligence must account for the entire critical period. *Griffith v. Kanamuru*, 816 F.2d 624, 626 (Fed. Cir. 1987); *Gould v. Schawlow*, 363 F.2d 908, 919 (CCPA 1966). Even a short period of unexplained inactivity is sufficient to defeat a claim of diligence. *Morway v. Bondi*, 203 F.2d 742, 749 (CCPA 1953); *Ireland v. Smith*, 97 F.2d 95, 99-100 (CCPA 1938). In *In re Mulder*, 716 F.2d 1542, 1542-46 (Fed. Cir. 1983), for example, the Federal Circuit affirmed a determination of lack of reasonable diligence, where the evidence of record was lacking for a two-day critical period. Likewise, in *Rieser v. Williams*, 255 F.2d 419, 424 (CCPA 1958), there was no showing of diligence where no activity was shown during the first thirteen days of the critical period.

A party alleging diligence must provide corroboration with evidence that is specific both as to facts and dates. *Gould*, 363 F.2d at 920; *Kendall v. Searles*, 173 F.2d 986, 993 (CCPA 1949). The rule of reason does not dispense with the need for corroboration of diligence that is specific as to dates and facts. *Gould*, 363 F.2d at 920; *Kendall*, 173 F.2d at 993; *see also Coleman v. Dines*, 754 F.2d 353, 360 (Fed. Cir. 1985).

On this record, Patent Owner has not shown that the 2004 Monroe Declaration addresses the continuous exercise of reasonable diligence adequately. For example, the 2004 Monroe Declaration shows extended periods of little activity that have not been adequately explained, such as between 1992 (the first comprehensive circuit for a handheld Remote Image Transceiver (“R.I.T.”)) and November 1995 (a concept proposal of a handheld R.I.T. using secure radio transmission), and between November 1995 and mid-1997 (a prototype of the first commercial embodiment of the invention). Both periods are subsequent to the effective filing dates of Reele

and Parulski.

Also, Patent Owner must establish conception and reduction to practice of the subject matter of *each* of the challenged claims. The 2004 Monroe Declaration fails to relate the claims of the '871 patent to the invention that is alleged to be earlier in time. For example, Mr. Monroe testifies to the dates on which he developed several R.I.T.'s, including a commercial handheld R.I.T. completed in late 1997. Ex. 1004 ¶¶ 9-17. The 2004 Monroe Declaration does not, however, relate any of the discussed R.I.T. devices to any element of any claim of the '871 patent. It is not clear, for example, that the 2004 Monroe Declaration adequately accounts for the "telephonic system" element of claim 1. According to the 2004 Monroe Declaration, cellular telephone compatibility was not present in the November 1995 proposal for a handheld R.I.T., but it was present in the final product completed in late 1997. Ex. 1004 ¶¶ 14, 17. As a result, it is not clear when Mr. Monroe conceived of a handheld R.I.T. that included cellular telephone computability. Even assuming that Mr. Monroe conceived of a handheld R.I.T. that included cellular telephone compatibility shortly after November 1995, that would not be earlier than the effective filing dates of Parulski and Reelee.

For the foregoing reasons, on the present record, we are persuaded by the Petitioner's argument that the 2004 Monroe Declaration, either by itself or in combination with the evidence currently of record, does not properly antedate Parulski and Reelee.

#### *B. Claim Construction*

In an *inter partes* review, claim terms in an unexpired patent are interpreted according to their "broadest reasonable construction in light of



the specification of the patent in which they appear.” 37 C.F.R. § 42.100(b); Office Patent Trial Practice Guide, 77 Fed. Reg. 48,756, 48,766 (Aug. 14, 2012). Also, claim terms are given their ordinary and customary meaning, as would be understood by one of ordinary skill in the art in the context of the entire disclosure. *In re Translogic Tech., Inc.*, 504 F.3d 1249, 1257 (Fed. Cir. 2007).

1. “*image capture device*” (claims 1, 2, 9)

Petitioner proposes that “image capture device” be construed to encompass at least “a digital camera or the electronic component of a digital camera that performs the actual image capture, which is typically a charge coupled device (CCD).” Pet. 6-7. As support for its proposed construction, Petitioner cites the Specification. *Id.* (citing Ex. 1001, Fig. 1, 5:30-32). Patent Owner does not dispute Petitioner’s proposed construction.

We, however, conclude that Petitioner’s proposed construction is unreasonably narrow to the extent that it excludes an analog image capture device, as described in the ’871 patent. Ex. 1001, 5:30-32. On this record, and for purposes of this Decision, we determine that the broadest reasonable interpretation of “image capture device” includes, but is not limited to, a digital camera and the component of a digital camera that performs the actual image capture.

2. “*digitized framed image*” (claims 1, 6, 9, 12)

Petitioner proposes that “digitized framed image” be construed to encompass at least “a digital photo image.” Pet. 7. As support for its proposed construction, Petitioner cites the Specification. *Id.* (citing Ex. 1001, Fig. 1, 5:30-32). Patent Owner does not dispute Petitioner’s proposed construction. The term “digitized framed image” is not used apart from the

claims. The claims require, however, that the “digitized framed image” be the image framed by the camera. The ’871 patent describes an exemplary “image capture device” as “a standard analog or digital camera device 10 for capturing a visual image in the typical fashion.” Ex. 1001, 5:30-32.

Accordingly, “digitized frame image” must be broad enough to encompass the output of a digital camera device. On this record, and for purposes of this Decision, we determine that “digitized framed image” is broad enough to include a digital photo image.

3. “*remote receiving station*” (claim 1)

Petitioner proposes that “content data” be construed to “encompass at least fax machines, cellular phones, and personal computers.” Pet. 7. As support for its proposed construction, Petitioner cites the Specification. *Id.* (citing Ex. 1001, Figs. 1-3, 2:39-43). Patent Owner does not dispute Petitioner’s proposed construction. The ’871 patent does not define the term “remote receiving station,” but describes it being “where the image is downloaded for viewing on a screen or printing on hard paper copy or other medium.” Ex. 1001, 4:67-5:2. The ’871 patent also describes “remote receiving devices, such as, by way of example, personal computers and network servers” (*id.* at 2:42-43, 13:8-9 and 21-23), “a remote Group-III receiving system 34” (*id.* at 5:54-55), and “a remote facsimile machine” (*id.* at 10:47). On this record, and for purposes of this Decision, we determine that “remote receiving station” is broad enough to encompass at least remote fax machines, remote cellular phones, and remote personal computers.

4. “*alphanumeric input keys*” (claims 1 and 9)

Petitioner proposes that “alphanumeric input keys” be construed to “encompass at least telephone keypads.” Pet. 7. As support for its proposed

construction, Petitioner cites the Specification. *Id.* (citing Ex. 1001, Fig. 7, 2:30-32, 11:19-20). Patent Owner does not dispute Petitioner's proposed construction. The term "alphanumeric input keys" is not used in the '871 patent, apart from the claims. The '871 patent does, however, describe an "integrated keyboard" (Ex. 1001, 2:30-32), "operator interface button keys 98" (*id.* at 11:8-9), and a "keypad for the telephone" (*id.* at 11:19-20). Moreover, Figures 6A-C and 7A depict embodiments with a conventional telephone keypad. On this record, and for purposes of this Decision, we determine that "alphanumeric input keys" is broad enough to include a telephone keypad.

*C. Challenged Claims – Obvious over Parulski and Reelee*

Petitioner argues that the claims 1-15 are unpatentable under 35 U.S.C. § 103(a) as obvious over Parulski and Reelee. Pet. 8-33.

*Parulski (Exhibit 1002)*

Parulski describes an electronic camera system that includes "a transmission mechanism for sending image data to selected receiver units." Ex. 1002, 1:14-16.

Figures 7, 8, and 9 of Parulski are reproduced below.

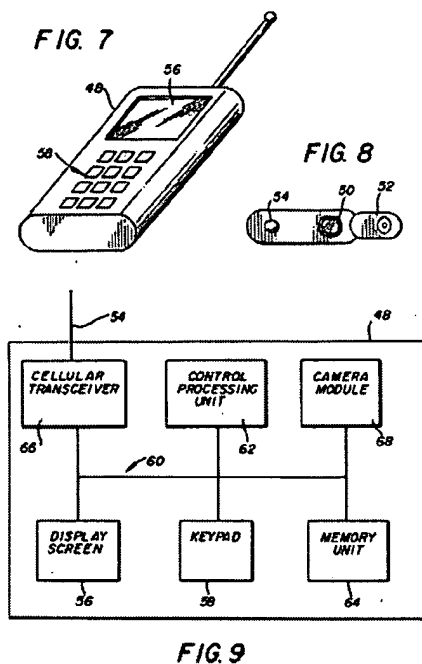

Figure 7 depicts combined telephone/camera unit 48 in accordance with a second embodiment of the invention of Parulski. *Id.* at 2:33-35. Figure 8 depicts a top view of combined telephone/camera unit 48. *Id.* at 2:36-37. Figure 9 is a schematic block diagram of the combined telephone/camera unit 48. *Id.* at 2:38-39. In the depicted embodiment, a cellular telephone is provided with the components of an electronic image camera to form a combined telephone/camera unit 48. *Id.* at 4:34-36. The combined unit 48 includes liquid crystal display screen 56 and telephone keypad 58. *Id.* at 4:38-43.

The user takes a picture by pressing an image capture switch (not shown) or, alternatively, a key on keypad 58. *Id.* at 4:48-53. “The digitized picture data generated by the camera module 68 is stored in memory unit 64 and displayed on display screen 56.” *Id.* at 4:53-55 (emphasis omitted). “To transmit the image, the user dials the telephone number of a desired fax

machine that is to receive the image using the keypad 58.” *Id.* at 4:56-58 (emphasis omitted). “The number is transmitted to the fax machine via the cellular transceiver 66.” *Id.* at 4:58-59 (emphasis omitted). “The stored image is then converted to the appropriate fax standard by control processing unit 62, and is transmitted to the receiving fax machine using the normal cellular telephone system that includes an RF link from cellular transceiver 66 to a cellular base unit, which connects to the normal wire, fiber, and satellite telephone system.” *Id.* at 4:62-67 (emphasis omitted).

Reele (Exhibit 1003)

Reele describes “an electronic/silver-halide image capture system that is capable of transmitting captured image data via cellular communication transmission.” *Id.* at 1:10-14.

Figure 4 of Reele is reproduced below.

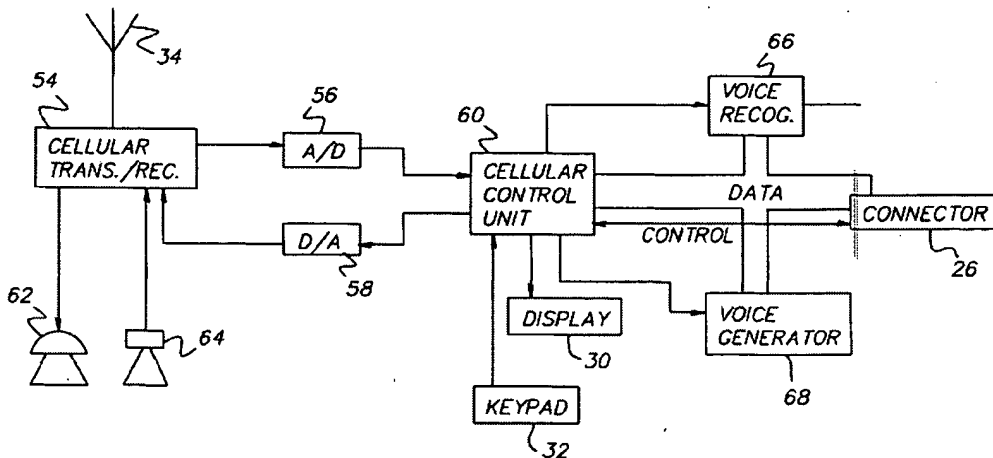

**FIG. 4**

Figure 4 depicts a functional block diagram of cellular telephone 28 illustrated in Figure 2. *Id.* at 2:49-50. Cellular phone 28 includes cellular transmitter/receiver circuit 54 coupled to antenna 34. *Id.* at 3:64-66. Cellular band voice transmission signals received by transmitter/receiver

circuit 54 are supplied to speaker 62. *Id.* at 3:66-4:1. Microphone 64 is coupled to transmitter/receiver circuit 54 to enable cellular band transmission of voice signals to remote locations. *Id.* at 4:1-4. Operation of transmitter/receiver circuit 54 is controlled by cellular control unit 60. *Id.* at 4:4-8. Cellular control unit 60 also is coupled to display 30 and keypad 32. *Id.* A/D converter 56 and D/A converter 58 permit analog signals received by transmitter/receiver circuit 54 from speaker 62 or antenna 34 to be converted to digital signals and supplied to cellular control unit 60. *Id.* at 4:8-15. A/D converter 56 and D/A converter 58 also permit digital data supplied from cellular control unit 60 to be converted to an analog signal for transmission by transmitter/receiver circuit 54. *Id.* Display 30 is used to display various messages to the operator of the telephone. *Id.* at 4:15-17. The reference states that “it will be understood that [telephone 28 and camera 10] may be readily combined within a single housing as an integrated module.” *Id.* at 4:47-51 (emphasis omitted).

Analysis

In light of the arguments and evidence, Petitioner has established a reasonable likelihood that claims 1-15 are unpatentable as obvious over Parulski and Reelee. Specifically, we are persuaded that Petitioner’s citations support Petitioner’s contentions. For example, Petitioner relies upon the combination of Parulski with Reelee. Pet. 14-33. Petitioner argues that “someone of ordinary skill in the art reading Parulski would have strong motivation to consider Reelee for its further teachings about combination camera-phone devices,” because Reelee is listed amongst the References Cited on the face of Parulski and because Reelee is directed to the same topic of camera-phone devices. Pet. 8. Petitioner describes Reelee’s disclosure

and argues that “there is motivation to add useful features disclosed by Reelee into the camera-phone of Parulski.” Pet. 12. On the record before us, we are persuaded that Petitioner has provided sufficiently an articulated reasoning with some rational underpinning to support the legal conclusion of obviousness. *See KSR*, 550 U.S. 418 (2007) (citing *In re Kahn*, 441 F.3d 977, 988 (Fed. Cir. 2006)).

Patent Owner does not argue that Parulski or Reelee fails to teach or suggest any limitation of claims 1-15.

Conclusion

On this record, we are persuaded that Petitioner has established a reasonable likelihood that it would prevail in showing that claims 1-15 are unpatentable as obvious over Parulski and Reelee.

III. CONCLUSION

For the foregoing reasons, we determine that Petitioner has established that there is a reasonable likelihood that Petitioner would prevail in establishing the unpatentability of claims 1-15 of the '871 patent.

The Board has not made a final determination on the patentability of any challenged claims.

IV. ORDER

Accordingly, it is

ORDERED that pursuant to 35 U.S.C. § 314, an *inter partes* review is hereby instituted for claims 1-15 under 35 U.S.C. § 103 as obvious over Parulski and Reelee; and

FURTHER ORDERED that pursuant to 35 U.S.C. § 314(d) and 37 C.F.R. § 42.4, notice is hereby given of the institution of a trial on the

IPR2014-00439  
Patent 7,365,871

grounds of unpatentability authorized above; the trial commences on the entry date of this Decision.



IPR2014-00439  
Patent 7,365,871

For PETITIONER:

Steven Yu  
ROZMED LLC  
[syu@patent-intercept.com](mailto:syu@patent-intercept.com)

For PATENT OWNER:

Robert C. Curfiss  
[bob@curfiss.com](mailto:bob@curfiss.com)

and

David O. Simmons  
IVC Patent Agency  
[dsimmons1@sbcglobal.net](mailto:dsimmons1@sbcglobal.net)



WJK

NOTICE OF ALLOWANCE AND FEE(S) DUE

67589 7590 12/27/2007
MOORE LANDREY
1609 SHOAL CREEK BLVD
AUSTIN, TX 78701

EXAMINER: SAFAIPOUR, HOUSHANG
ART UNIT: 2625 PAPER NUMBER:
DATE MAILED: 12/27/2007

Table with 5 columns: APPLICATION NO., FILING DATE, FIRST NAMED INVENTOR, ATTORNEY DOCKET NO., CONFIRMATION NO.
10/336,470 01/03/2003 David A. Monroe 07-0197 8448
TITLE OF INVENTION: APPARATUS FOR CAPTURING, CONVERTING AND TRANSMITTING A VISUAL IMAGE SIGNAL VIA A DIGITAL TRANSMISSION SYSTEM

Table with 7 columns: APPLN. TYPE, SMALL ENTITY, ISSUE FEE DUE, PUBLICATION FEE DUE, PREV. PAID ISSUE FEE, TOTAL FEE(S) DUE, DATE DUE
nonprovisional NO \$1440 \$300 \$0 \$1740 03/27/2008

THE APPLICATION IDENTIFIED ABOVE HAS BEEN EXAMINED AND IS ALLOWED FOR ISSUANCE AS A PATENT. PROSECUTION ON THE MERITS IS CLOSED. THIS NOTICE OF ALLOWANCE IS NOT A GRANT OF PATENT RIGHTS. THIS APPLICATION IS SUBJECT TO WITHDRAWAL FROM ISSUE AT THE INITIATIVE OF THE OFFICE OR UPON PETITION BY THE APPLICANT. SEE 37 CFR 1.313 AND MPEP 1308.

THE ISSUE FEE AND PUBLICATION FEE (IF REQUIRED) MUST BE PAID WITHIN THREE MONTHS FROM THE MAILING DATE OF THIS NOTICE OR THIS APPLICATION SHALL BE REGARDED AS ABANDONED. THIS STATUTORY PERIOD CANNOT BE EXTENDED. SEE 35 U.S.C. 151. THE ISSUE FEE DUE INDICATED ABOVE DOES NOT REFLECT A CREDIT FOR ANY PREVIOUSLY PAID ISSUE FEE IN THIS APPLICATION. IF AN ISSUE FEE HAS PREVIOUSLY BEEN PAID IN THIS APPLICATION (AS SHOWN ABOVE), THE RETURN OF PART B OF THIS FORM WILL BE CONSIDERED A REQUEST TO REAPPLY THE PREVIOUSLY PAID ISSUE FEE TOWARD THE ISSUE FEE NOW DUE.

HOW TO REPLY TO THIS NOTICE:

I. Review the SMALL ENTITY status shown above.

If the SMALL ENTITY is shown as YES, verify your current SMALL ENTITY status:

- A. If the status is the same, pay the TOTAL FEE(S) DUE shown above.
B. If the status above is to be removed, check box 5b on Part B - Fee(s) Transmittal and pay the PUBLICATION FEE (if required) and twice the amount of the ISSUE FEE shown above, or

If the SMALL ENTITY is shown as NO:

- A. Pay TOTAL FEE(S) DUE shown above, or
B. If applicant claimed SMALL ENTITY status before, or is now claiming SMALL ENTITY status, check box 5a on Part B - Fee(s) Transmittal and pay the PUBLICATION FEE (if required) and 1/2 the ISSUE FEE shown above.

II. PART B - FEE(S) TRANSMITTAL, or its equivalent, must be completed and returned to the United States Patent and Trademark Office (USPTO) with your ISSUE FEE and PUBLICATION FEE (if required). If you are charging the fee(s) to your deposit account, section "4b" of Part B - Fee(s) Transmittal should be completed and an extra copy of the form should be submitted. If an equivalent of Part B is filed, a request to reapply a previously paid issue fee must be clearly made, and delays in processing may occur due to the difficulty in recognizing the paper as an equivalent of Part B.

III. All communications regarding this application must give the application number. Please direct all communications prior to issuance to Mail Stop ISSUE FEE unless advised to the contrary.

IMPORTANT REMINDER: Utility patents issuing on applications filed on or after Dec. 12, 1980 may require payment of maintenance fees. It is patentee's responsibility to ensure timely payment of maintenance fees when due.

**PART B - FEE(S) TRANSMITTAL**

Complete and send this form, together with applicable fee(s), to: **Mail** Mail Stop ISSUE FEE  
 Commissioner for Patents  
 P.O. Box 1450  
 Alexandria, Virginia 22313-1450  
 or **Fax** (571)-273-2885

**INSTRUCTIONS:** This form should be used for transmitting the ISSUE FEE and PUBLICATION FEE (if required). Blocks 1 through 5 should be completed where appropriate. All further correspondence including the Patent, advance orders and notification of maintenance fees will be mailed to the current correspondence address as indicated unless corrected below or directed otherwise in Block 1, by (a) specifying a new correspondence address; and/or (b) indicating a separate "FEE ADDRESS" for maintenance fee notifications.

CURRENT CORRESPONDENCE ADDRESS (Note: Use Block 1 for any change of address)

67589 7590 12/27/2007

**MOORE LANDREY**  
 1609 SHOAL CREEK BLVD  
 AUSTIN, TX 78701

Note: A certificate of mailing can only be used for domestic mailings of the Fee(s) Transmittal. This certificate cannot be used for any other accompanying papers. Each additional paper, such as an assignment or formal drawing, must have its own certificate of mailing or transmission.

**Certificate of Mailing or Transmission**

I hereby certify that this Fee(s) Transmittal is being deposited with the United States Postal Service with sufficient postage for first class mail in an envelope addressed to the Mail Stop ISSUE FEE address above, or being facsimile transmitted to the USPTO (571) 273-2885, on the date indicated below.

|                    |
|--------------------|
| (Depositor's name) |
| (Signature)        |
| (Date)             |

| APPLICATION NO. | FILING DATE | FIRST NAMED INVENTOR | ATTORNEY DOCKET NO. | CONFIRMATION NO. |
|-----------------|-------------|----------------------|---------------------|------------------|
|-----------------|-------------|----------------------|---------------------|------------------|

10/336,470 01/03/2003 David A. Monroe 07-0197 8448

TITLE OF INVENTION: APPARATUS FOR CAPTURING, CONVERTING AND TRANSMITTING A VISUAL IMAGE SIGNAL VIA A DIGITAL TRANSMISSION SYSTEM

| APPLN. TYPE | SMALL ENTITY | ISSUE FEE DUE | PUBLICATION FEE DUE | PREV. PAID ISSUE FEE | TOTAL FEE(S) DUE | DATE DUE |
|-------------|--------------|---------------|---------------------|----------------------|------------------|----------|
|-------------|--------------|---------------|---------------------|----------------------|------------------|----------|

nonprovisional NO \$1440 \$300 \$0 \$1740 03/27/2008

| EXAMINER | ART UNIT | CLASS-SUBCLASS |
|----------|----------|----------------|
|----------|----------|----------------|

SAFAIPOUR, HOUSHANG 2625 358-474000

1. Change of correspondence address or indication of "Fee Address" (37 CFR 1.363).

- Change of correspondence address (or Change of Correspondence Address form PTO/SB/122) attached.
- "Fee Address" indication (or "Fee Address" Indication form PTO/SB/47; Rev 03-02 or more recent) attached. Use of a Customer Number is required.

2. For printing on the patent front page, list

- (1) the names of up to 3 registered patent attorneys or agents OR, alternatively, 1 \_\_\_\_\_
- (2) the name of a single firm (having as a member a registered attorney or agent) and the names of up to 2 registered patent attorneys or agents. If no name is listed, no name will be printed. 2 \_\_\_\_\_
- 3 \_\_\_\_\_

3. ASSIGNEE NAME AND RESIDENCE DATA TO BE PRINTED ON THE PATENT (print or type)

PLEASE NOTE: Unless an assignee is identified below, no assignee data will appear on the patent. If an assignee is identified below, the document has been filed for recordation as set forth in 37 CFR 3.11. Completion of this form is NOT a substitute for filing an assignment.

(A) NAME OF ASSIGNEE (B) RESIDENCE: (CITY AND STATE OR COUNTRY)

Please check the appropriate assignee category or categories (will not be printed on the patent):  Individual  Corporation or other private group entity  Government

4a. The following fee(s) are submitted:

- Issue Fee
- Publication Fee (No small entity discount permitted)
- Advance Order - # of Copies \_\_\_\_\_

4b. Payment of Fee(s): (Please first reapply any previously paid issue fee shown above)

- A check is enclosed.
- Payment by credit card. Form PTO-2038 is attached.
- The Director is hereby authorized to charge the required fee(s), any deficiency, or credit any overpayment, to Deposit Account Number \_\_\_\_\_ (enclose an extra copy of this form).

5. Change in Entity Status (from status indicated above)

- a. Applicant claims SMALL ENTITY status. See 37 CFR 1.27.
- b. Applicant is no longer claiming SMALL ENTITY status. See 37 CFR 1.27(g)(2).

NOTE: The Issue Fee and Publication Fee (if required) will not be accepted from anyone other than the applicant; a registered attorney or agent; or the assignee or other party in interest as shown by the records of the United States Patent and Trademark Office.

Authorized Signature \_\_\_\_\_ Date \_\_\_\_\_  
 Typed or printed name \_\_\_\_\_ Registration No. \_\_\_\_\_

This collection of information is required by 37 CFR 1.311. The information is required to obtain or retain a benefit by the public which is to file (and by the USPTO to process) an application. Confidentiality is governed by 35 U.S.C. 122 and 37 CFR 1.14. This collection is estimated to take 12 minutes to complete, including gathering, preparing, and submitting the completed application form to the USPTO. Time will vary depending upon the individual case. Any comments on the amount of time you require to complete this form and/or suggestions for reducing this burden, should be sent to the Chief Information Officer, U.S. Patent and Trademark Office, U.S. Department of Commerce, P.O. Box 1450, Alexandria, Virginia 22313-1450. DO NOT SEND FEES OR COMPLETED FORMS TO THIS ADDRESS. SEND TO: Commissioner for Patents, P.O. Box 1450, Alexandria, Virginia 22313-1450.

Under the Paperwork Reduction Act of 1995, no persons are required to respond to a collection of information unless it displays a valid OMB control number.



UNITED STATES PATENT AND TRADEMARK OFFICE

UNITED STATES DEPARTMENT OF COMMERCE
United States Patent and Trademark Office
Address: COMMISSIONER FOR PATENTS
P.O. Box 1450
Alexandria, Virginia 22313-1450
www.uspto.gov

Table with columns: APPLICATION NO., FILING DATE, FIRST NAMED INVENTOR, ATTORNEY DOCKET NO., CONFIRMATION NO., EXAMINER, ART UNIT, PAPER NUMBER. Includes application details for David A. Monroe and examiner Safaipour, Houshang.

Determination of Patent Term Adjustment under 35 U.S.C. 154 (b)
(application filed on or after May 29, 2000)

The Patent Term Adjustment to date is 0 day(s). If the issue fee is paid on the date that is three months after the mailing date of this notice and the patent issues on the Tuesday before the date that is 28 weeks (six and a half months) after the mailing date of this notice, the Patent Term Adjustment will be 0 day(s).

If a Continued Prosecution Application (CPA) was filed in the above-identified application, the filing date that determines Patent Term Adjustment is the filing date of the most recent CPA.

Applicant will be able to obtain more detailed information by accessing the Patent Application Information Retrieval (PAIR) WEB site (http://pair.uspto.gov).

Any questions regarding the Patent Term Extension or Adjustment determination should be directed to the Office of Patent Legal Administration at (571)-272-7702. Questions relating to issue and publication fee payments should be directed to the Customer Service Center of the Office of Patent Publication at 1-(888)-786-0101 or (571)-272-4200.

**Notice of Allowability**

|                                       |   |  |
|---------------------------------------|---|--|
| <b>Application No.</b><br>10/336,470  | <b>Applicant(s)</b><br>MONROE, DAVID A. |  |
| <b>Examiner</b><br>Houshang Safaipour | <b>Art Unit</b><br>2625                 |  |

**-- The MAILING DATE of this communication appears on the cover sheet with the correspondence address--**

All claims being allowable, PROSECUTION ON THE MERITS IS (OR REMAINS) CLOSED in this application. If not included herewith (or previously mailed), a Notice of Allowance (PTOL-85) or other appropriate communication will be mailed in due course. **THIS NOTICE OF ALLOWABILITY IS NOT A GRANT OF PATENT RIGHTS.** This application is subject to withdrawal from issue at the initiative of the Office or upon petition by the applicant. See 37 CFR 1.313 and MPEP 1308.

1.  This communication is responsive to an amendment filed on 10/13/2007.
2.  The allowed claim(s) is/are 43-45, 48, 50-52, 54, 55, 60 and 62-66.
3.  Acknowledgment is made of a claim for foreign priority under 35 U.S.C. § 119(a)-(d) or (f).
  - a)  All    b)  Some\*    c)  None    of the:
    1.  Certified copies of the priority documents have been received.
    2.  Certified copies of the priority documents have been received in Application No. \_\_\_\_\_.
    3.  Copies of the certified copies of the priority documents have been received in this national stage application from the International Bureau (PCT Rule 17.2(a)).

\* Certified copies not received: \_\_\_\_\_.

Applicant has THREE MONTHS FROM THE "MAILING DATE" of this communication to file a reply complying with the requirements noted below. Failure to timely comply will result in ABANDONMENT of this application.  
**THIS THREE-MONTH PERIOD IS NOT EXTENDABLE.**

4.  A SUBSTITUTE OATH OR DECLARATION must be submitted. Note the attached EXAMINER'S AMENDMENT or NOTICE OF INFORMAL PATENT APPLICATION (PTO-152) which gives reason(s) why the oath or declaration is deficient.
  5.  CORRECTED DRAWINGS ( as "replacement sheets") must be submitted.
    - (a)  including changes required by the Notice of Draftsperson's Patent Drawing Review ( PTO-948) attached
      - 1)  hereto or 2)  to Paper No./Mail Date \_\_\_\_\_.
    - (b)  including changes required by the attached Examiner's Amendment / Comment or in the Office action of Paper No./Mail Date \_\_\_\_\_.
- Identifying indicia such as the application number (see 37 CFR 1.84(c)) should be written on the drawings in the front (not the back) of each sheet. Replacement sheet(s) should be labeled as such in the header according to 37 CFR 1.121(d).
6.  DEPOSIT OF and/or INFORMATION about the deposit of BIOLOGICAL MATERIAL must be submitted. Note the attached Examiner's comment regarding REQUIREMENT FOR THE DEPOSIT OF BIOLOGICAL MATERIAL.

**Attachment(s)**

- |  |  |
|--|--|
| 1. <input checked="" type="checkbox"/> Notice of References Cited (PTO-892)                                | 5. <input type="checkbox"/> Notice of Informal Patent Application                      |
| 2. <input type="checkbox"/> Notice of Draftsperson's Patent Drawing Review (PTO-948)                       | 6. <input type="checkbox"/> Interview Summary (PTO-413),<br>Paper No./Mail Date _____. |
| 3. <input type="checkbox"/> Information Disclosure Statements (PTO/SB/08),<br>Paper No./Mail Date _____    | 7. <input checked="" type="checkbox"/> Examiner's Amendment/Comment                    |
| 4. <input type="checkbox"/> Examiner's Comment Regarding Requirement for Deposit<br>of Biological Material | 8. <input checked="" type="checkbox"/> Examiner's Statement of Reasons for Allowance   |
|  | 9. <input type="checkbox"/> Other _____.   |



***Reasons for Allowance***

1. Claims 1-42, 46, 47, 49, 53, 56-59 and 61 are canceled.
2. Claims 43-45, 48, 50-52, 54, 55, 60 and 62-66 are allowed.
3. This is examiner's statement of reasons for allowance.

Regarding claims 43-45, 48 and 50, the prior art, either singularly or in combination, does not teach or suggest a handheld self-contained cellular telephone and integrated image processing system for both sending and receiving telephonic audio signals and for capturing a visual image and transmitting it to a compatible remote receiving station of a wireless telephone network, the system comprising:

an integral image capture device comprising an electronic camera contained within the portable housing; a display for displaying an image framed by the camera, the display being supported by the housing, the display and the electronic camera being commonly movable in the housing when the housing is moved by hand; a memory associated with the processor for receiving and storing the digitized framed image, accessible for selectively displaying in the display window and accessible for selectively transmitting over the wireless telephone network the digitized framed image;

Regarding claims 51, 52, and 54, the prior art, either singularly or in combination, does not teach or suggest a handheld cellular telephone having an integrated electronic camera for both sending and receiving telephonic audio signals and for capturing a visual image, converting

the visual image to a digitized image data signal and transmitting digitized image data signal via a cellular telephone network, the cellular telephone comprising:

a manually portable housing supporting the cellular telephone and the integrated electronic camera, the cellular telephone and the integrated electronic camera being movable in common with the housing; an integral electronic camera in the housing, the camera for visually framing a visual image to be captured; a processor associated with the electronic camera for capturing and digitizing the framed image in a format for transmission over the cellular telephone network via the cellular telephone; a memory associated with the processor for receiving and storing the digitized framed image, accessible for selectively displaying in the display window and accessible for selectively transmitting over the cellular telephone network the digitized framed image;

Regarding claims 55, 60, and 62-66, the prior art, either singularly or in combination, does not teach or suggest a combination of handheld cellular telephone and electronic camera comprising:

an electronic camera integral within the housing; a display in the housing for framing the image to be captured by an image capture device and for viewing the image whereby an operator can view and frame the image prior to capture; a memory associated with the processor for receiving and storing the digitized framed image for selectively displaying the digitized framed image in the display window and for selectively transmitting the digitized framed image over a cellular telephone network; a cellular telephone in the housing for accepting and digitizing audio signals to be transmitted and for converting received digitized audio signals into acoustic audio,

the cellular telephone further for transmitting and receiving non-audio digital signals including digitized image signals;

The features identified, in combination with other claim limitations, are neither suggested nor discussed by the prior art of record.

Any comments considered necessary by applicant must be submitted no later than the payment of the issue fee and, to avoid processing delays, should preferably accompany the issue fee. Such submissions should be clearly labeled "Comments on Statement of Reasons for Allowance."

4. ***Contact Information***

Any inquiry concerning this communication or earlier communications from the examiner should be directed to Houshang Safaipour whose telephone number is (571)272-7412. The examiner can normally be reached on Mon.-Thurs. from 6:30am to 3:00pm.

If attempts to reach the examiner by telephone are unsuccessful, the examiner's supervisor, David Moore whose telephone number is (571)272-7437. The fax phone number for the organization where this application or proceeding is assigned is (571)273-8300.



Application/Control Number:  
10/336,470  
Art Unit: 2625

Page 8

Information regarding the status of an application may be obtained from the Patent Application Information Retrieval (PAIR) system. Status information for published applications may be obtained from either Private PAIR or Public PAIR. Status information for unpublished applications is available through Private PAIR only. For more information about the PAIR system, see <http://pair-direct.uspto.gov>. Should you have questions on access to the Private PAIR system, contact the Electronic Business Center (EBC) at 866-217-9197 (toll-free).

Houshang Safaipoor  
Patent Examiner  
November 26, 2007

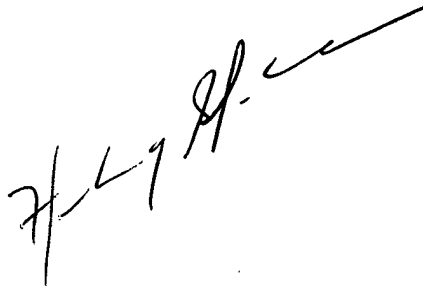
A handwritten signature in black ink, appearing to read 'H. Safaipoor', written diagonally across the page.

**DETAILED ACTION**

***EXAMINER'S AMENDMENT***

1. An examiner's amendment to the record appears below. Should the changes and/or additions be unacceptable to applicant, an amendment may be filed as provided by CFR 1.312. To ensure consideration of such an amendment, it **MUST** be submitted no later than the payment of issue fee.

Authorization to amend the claims was given in telephone interview with Jeffery D. Hunt (Registration No. 38,189) on November 26, 2007.

2. In the Claims:

43. (currently amended) A handheld self-contained cellular telephone and integrated image processing system for both sending and receiving telephonic audio signals and for capturing a visual image and transmitting it to a compatible remote receiving station of a wireless telephone network, the system comprising:

a manually portable housing;

an integral image capture device comprising an electronic camera contained within the portable housing;

a display for displaying an image framed by the camera, the display being supported by the housing, the display and the electronic camera being commonly movable in the housing when the housing is moved by hand;

a processor in the housing for generating an image data signal representing the image framed by the camera;

a memory associated with the processor for receiving and storing the digitized framed image, accessible for selectively displaying in the display window and accessible for selectively transmitting over the wireless telephone network the digitized framed image;

a user interface for enabling a user to select the image data signal for viewing and transmission;

a telephonic system in the housing for sending and receiving digitized audio signals and for sending the image data signal;

alphanumeric input keys in the housing for permitting manually input digitized alphanumeric signals to be input to the processor, the telephonic system further used for sending the digitized alphanumeric signals;

a wireless communications device adapted for transmitting any of the digitized signals to the compatible remote receiving station; and

a power supply for powering the system.

51. (currently amended) A handheld cellular telephone having an integrated electronic camera for both sending and receiving telephonic audio signals and for capturing a visual image, converting the visual image to a digitized image data signal and transmitting digitized image data signal via a cellular telephone network, the cellular telephone comprising:

a manually portable housing supporting the cellular telephone and the integrated electronic camera, the cellular telephone and the integrated electronic camera being movable in common with the housing;

a cellular telephone in the housing, the cellular telephone further including a transmitter/receiver for transmitting and receiving audio telephone messages over a cellular telephone network, a keypad for entering manually input alphanumeric signals to be transmitted over the cellular telephone network, and a display window for viewing the manually input alphanumeric signals:

an integral electronic camera in the housing, the camera for visually framing a visual image to be captured;

a processor associated with the electronic camera for capturing and digitizing the framed image in a format for transmission over the cellular telephone network via the cellular telephone;

a memory associated with the processor for receiving and storing the digitized framed image, accessible for selectively displaying in the display window and accessible for selectively transmitting over the cellular telephone network the digitized framed image;

a user interface for enabling a user to selectively display the digitized framed image in the display window and subsequently transmit the digitized framed image over the cellular telephone network; and

an integrated power supply for powering both the cellular telephone and the camera.



Houhang Safaipoor  
Patent Examiner

**IN THE UNITED STATES PATENT AND TRADEMARK OFFICE**

|                                  |   |                                  |  |
|----------------------------------|---|----------------------------------|--|
| In re Applicant:                 | § |                                  |  |
|                                  | § |                                  |  |
| DAVID A. MONROE                  | § |                                  |  |
|                                  | § |                                  |  |
| Filed:           January 3, 2003 | § | Art Unit:       2625             |  |
|                                  | § |                                  |  |
| Serial No.:     10/336,470       | § | Examiner:     Houshang Safaipour |  |
|                                  | § |                                  |  |
| For:   APPARATUS FOR             | § | Docket No.:   07-0197            |  |
| CAPTURING, CONVERTING            | § |                                  |  |
| AND TRANSMITTING A               | § |                                  |  |
| VISUAL IMAGE SIGNAL VIA          | § |                                  |  |
| A DIGITAL TRANSMISSION           | § |                                  |  |
| SYSTEM                           | § |                                  |  |

**RESPONSE TO NON-FINAL OFFICE ACTION DATED MARCH 8, 2007**

Commissioner for Patents  
P.O. Box 1450  
Alexandria, VA 22313-1450

Dear Sir:

Responsive to the Non-Final Office Action mailed March 8, 2007, please amend the application as indicated below. Pursuant to 37 CFR 1.16, the amendment is believed to place the application in condition for allowance or in better form for appeal. A Request for three month Extension of Time and the Extension Fee (\$1020.00) are attached. Also submitted herewith are a Supplemental Information Disclosure Statement and the fee (\$180.00) under 1.17(p) for consideration of the IDS after the first Office Action was mailed.

Amendments to the Claims begin on page 2 of this paper.

Remarks/Arguments begin on page 59 of this paper.

## Amendments

### Amendments to Specification:

Delete paragraph [0003] which reads:

Industry has developed and continues to develop and enhance techniques for scanning, compressing, transmitting, receiving, decompressing, viewing and printing documents. This technology, encompassing the full body of facsimile transmission and reception, is currently in widespread use. The current standards, CCITT Group III and Group IV, define methods to scan and transmit high quality, bi-level images with a high degree of success and has become commercially acceptable throughout the world. However, gray scale documents are not easily transmitted because the scanners and algorithms are not tailored to the function. Three dimensional objects will not fit into the flat document scanners and cannot be transmitted.

Delete paragraph [0004] which reads:

Examples of systems that have addressed some of these issues are shown in U.S. Patent No. 5,193,012 which shows a video to facsimile signal converter, and U.S. Patent No. 3,251,937 which discloses a system for transmitting still television pictures over a telephone line.

Delete paragraph [0005] which reads:

Wire photography, and its extension, radio photography, have long been used by the news media. The most common form involves an input device that converts photographs into encoded signals for communication over telecommunications facilities or radio. At the receiving end, reproducing equipment reconverts the encoded image signals by exposing photographic film or other sensitized paper. The term

facsimile is often used with these products.

Delete paragraph [0006] which reads:

Still video equipment has recently become available from vendors such as Kodak, Canon and Sony, and is again primarily used by television and print media, although applications are expanding rapidly in such areas as insurance investigations and real estate transactions. A still video camera captures a full color still video image that can be reproduced using a special video printer that converts the still video image data into hard copy form. For applications requiring communication of the still video image, transmit/receive units are available wherein the image begins and ends as a video image.

Delete paragraph [0007] which reads:

The Photophone from Image Data Corporation is an example of a specialty product that combines a video camera, display and storage facility in a terminal package. One terminal can send a real time or stored still video image to another for display or storage, or printing on special video printers. Again, the signal begins and ends as a video image.

Delete paragraph [0008] which reads:

Another example of a specialty product is peripheral equipment available for personal computers that enables the input/output, storage and processing of still video images in digitized formats. For instance, the Canon PV-540 is a floppy disk drive that uses

conventional still video disks, digitizing and a still video image using a conventional format, and communicates with the computer through a standard communications 110 port.

Delete paragraph [0009] which reads:

U.S. Patent No. 5,193,012 discloses a still-video to facsimile conversion system for converting the still-video image frame into a half-tone facsimile reproduction without having to store an entire intermediated gray scale image frame by repeatedly transmitting the still-video image frame from a still-video source to an input circuit with a virtual facsimile page synchronization module. This system permits image to facsimile conversion by utilizing a half tone conversion technique.

Delete paragraph [0010], which reads:

While the various prior art systems and techniques provide limited solutions to the problem of transmitting visual images via a facsimile transmission system, all fall short of providing a reliable and convenient method and apparatus for readily capturing, storing, transmitting and printing visual images in a practical manner.

Replace paragraph [0011] which reads:

The subject invention is an image capture, compression and transmission system that is specifically designed to permit reliable visual image transmission over land line or wireless communications using commercially available facsimile transmission techniques. The invention incorporates a camera and signal converter into an



integrated unit wherein the converted signal may be transmitted on a real time basis or may be stored in memory for later recall and transmission. The design of the invention permits maximum flexibility, with the camera/converter/telephone or other transmission device being designed in a modular configuration wherein any or all of the devices may exist as integrated or independent units.

with the following paragraph:

~~The subject invention is~~ Embodiments provide an image capture, compression and transmission system that is specifically designed to permit reliable visual image transmission over land line or wireless communications using commercially available facsimile transmission techniques. ~~The invention incorporates~~ Embodiments incorporate a camera and signal converter into an integrated unit wherein the converted signal [may] can be transmitted on a real time basis or may be stored in memory for later recall and transmission. ~~The design of the invention permits~~ Embodiments provide maximum flexibility, with the camera/converter/telephone or other transmission device being designed in a modular configuration wherein any or all of the devices [may] can exist as integrated or independent units.

Replace paragraph [0012] which reads:

The preferred embodiment permits capture of a video image using a digital camera, an analog camera, or a video camera such as a camcorder. The captured video image is then converted into still frame digitized format for transmission over any of a variety of transmission systems ranging from Group- III facsimile to computer, or to a like

device at a remote location, in any protocol desired. The invention recognizes that once a signal is digitized, the transmission protocols are virtually endless.

with the following paragraph:

~~The preferred embodiment permits~~ Embodiments permit capture of a video image using a digital camera, an analog camera, or a video camera such as a camcorder. The captured video image is then converted into still frame digitized format for transmission over any of a variety of transmission systems ranging from Group- III facsimile to computer, or to a like device at a remote location, in any protocol desired. ~~The invention recognizes that~~ According to embodiments, once a signal is digitized, the transmission protocols are virtually endless.

Replace paragraph [0013] which reads:

For example, the present invention, permits a still frame visual image to be captured at a remote location and sent immediately, over wireless communication systems, to a remote location such as, by way of example, a computer system wherein the image could be merged directly into newsprint. The image may also be sent to and printed as a hard copy using any Group-III facsimile machine, anywhere in the world. Where desired, the images may be stored in memory for later recall, and may be archived on a portable medium such as a memory card or the like.

with the following paragraph:

~~For example, the present invention, permits~~ Embodiments permit a still frame visual image to be captured at a remote location and sent immediately, over wireless communication systems, to a remote location such as, by way of example, a computer system wherein the image could be merged directly into newsprint. The image may also be sent to and printed as a hard copy using any Group-III facsimile machine, anywhere in the world. Where desired, the images may be stored in memory for later recall, and may be archived on a portable medium such as a memory card or the like.

Replace paragraph [0014] which reads:

The system of the subject invention is particularly useful for applications where immediate transmission of visual images of scenes, people and objects is desirable and sophisticated equipment is not always available for receiving the information. The system also provides a unique and reliable means for transmitting visual data to and from remote locations, such as, by way of example, law enforcement and emergency vehicles and the like.

with the following paragraph:

~~The system of the subject invention is particularly~~ Embodiments are useful for applications where immediate transmission of visual images of scenes, people and objects is desirable and sophisticated equipment is not always available for receiving the information. ~~The system also provides~~ Embodiments also provide a unique and reliable means for transmitting visual data to and from remote locations, such as, by way of example, law enforcement and emergency vehicles and the like.

Replace paragraph [0015] which reads:

In the preferred embodiment of the invention, the system includes a video camera and an integral cellular telephone, wherein the telephone using the standard audio mode or future digital modes, can be used to transmit and receive visual image signals. A desk model is also disclosed and permits connection to a standard land line telephonic system. A mobile console model is disclosed for use in law enforcement vehicles, and the like. Other communication systems are also supported by the subject invention, including hardwired networks, radio and satellite transmissions and the like.

with the following paragraph:

In [the preferred] an embodiment [of the invention, the] a system includes a video camera and an integral cellular telephone, wherein the telephone using the standard audio mode or future digital modes, can be used to transmit and receive visual image signals. An embodiment including a [A] desk model is also disclosed and permits connection to a standard land line telephonic system. An embodiment including a [A] mobile console model is disclosed for use in law enforcement vehicles, and the like. Other communication systems are also supported by [the subject invention] embodiments, including hardwired networks, radio and satellite transmissions and the like.

Replace paragraph [0016] which reads:

A local facsimile machine may be incorporated with the unit and can serve as a printer for providing hard copy of the captured image at the point of capture, as well as being adapted for receiving facsimile transmissions in the standard fashion.

with the following paragraph:

[A] In embodiments, a local facsimile machine [may] can be incorporated with the unit and can serve as a printer for providing hard copy of the captured image at the point of capture, as well as being adapted for receiving facsimile transmissions in the standard fashion.

Replace paragraph [0017] which reads:

The circuitry is disclosed for supporting any of the preferred configurations from a basic real time transmission system via Group-III fax to a comprehensive system supporting both land line and wireless transmission of image, audio and documentary data at both a local and remote station.

with the following paragraph:

Embodiments disclose [The] circuitry [is disclosed] for supporting any [of the preferred] configurations from a basic real time transmission system via Group-III fax to a comprehensive system supporting both land line and wireless transmission of image, audio and documentary data at both a local and remote station.

Replace paragraph [0018] which reads:

The subject invention also permits digitized collection of audio signals through the use of an internal microphone, and external input device, a cellular telephone, land line telephone, wireless radio or other communication system, and digitized audio playback, as well. The playback can be via an internal speaker, out an external out jack to a remote device or via a cellular telephone, land line telephone, wireless radio or other communication system.

with the following paragraph:

[The subject invention also permits] Embodiments permit digitized collection of audio signals through the use of an internal microphone, and external input device, a cellular telephone, land line telephone, wireless radio or other communication system, and digitized audio playback, as well. The playback can be via an internal speaker, out an external out jack to a remote device or via a cellular telephone, land line telephone, wireless radio or other communication system.

Replace paragraph [0019] which reads:

The digitized image and audio capture features permit association of audio with an image, as well as data with the image. Useful data associated with the image includes GPS from either internal or external GPS devices, range information from ranging devices, date and time, and text which may be input from an integrated keyboard or from a remote device.

with the following paragraph:

In embodiments, [The] digitized image and audio capture features permit association of audio with an image, as well as data with the image. Useful data associated with the image includes GPS from either internal or external GPS devices, range information from ranging devices, date and time, and text which may be input from an integrated keyboard or from a remote device.

Replace paragraph [0020] which reads:

It is an important feature of the invention that the system supports storage of images in an interim storage format including raw video, compressed video, interim gray scale format and/or half tone format. The image can also be stored in the selected output mode, such as by way of example, a Group-III facsimile mode. The versatile capability of the system permits transmission of captured data to a standard bi-level facsimile machine such as Group-III, to gray scale facsimile systems or full color facsimile systems, as well as to other remote receiving devices such as, by way of example, personal computers and network servers. The data may be configured in any of a variety of formats and protocols including JPEG, FAX, wireless, emerging imagery formats, FAX and computer data protocols. The invention is adapted to operate in multiple modes, with a unitary capture and send mode or separate capture and store, and send modes.

with the following paragraph:

In embodiments, a [It is an important feature of the invention that the] system supports storage of images in an interim storage format including raw video,

compressed video, interim gray scale format and/or half tone format. In embodiments, the [The] image can also be stored in the selected output mode, such as by way of example, a Group-III facsimile mode. [The] According to embodiments, the versatile capability of [the] a system permits transmission of captured data to a standard bi-level facsimile machine such as Group-III, to gray scale facsimile systems or full color facsimile systems, as well as to other remote receiving devices such as, by way of example, personal computers and network servers. The data [may] can be configured in any of a variety of formats and protocols including JPEG, FAX, wireless, emerging imagery formats, FAX and computer data protocols. [The invention is] Embodiments are adapted to operate in multiple modes, with a unitary capture and send mode or separate capture and store, and send modes.

Replace paragraph [0021] which reads:

In the preferred embodiment, the system is adapted for tagging a collected image, video, audio, and other data such as GPS information, with geospatial information and real time clock and added text. This permits the complete historical data to be transmitted simultaneously with the image signal.

with the following paragraph:

[In the preferred embodiment] In an embodiment, the system is adapted for tagging a collected image, video, audio, and other data such as GPS information, with geospatial information and real time clock and added text. This permits the complete historical data to be transmitted simultaneously with the image signal.



Replace paragraph [0022] which reads:

It is contemplated that the system of the invention would be self-contained with an integral power unit such as a disposable battery, rechargeable battery source or the like.

with the following paragraph:

According to embodiments, [It] it is contemplated that [the] a system [of the invention would] can be self-contained with an integral power unit such as a disposable battery, rechargeable battery source or the like.

Replace paragraph [0023] which reads:

Where desired, the system also includes camera operation control capability through the use of digital/analog circuits for converting digital commands to analog signals for controlling the gain, pedestal, setup, white clip, lens focus, white balance, lens iris, lens zoom and other functions of the camera from a local input device, a remote device or as automatic or programmed functions. The central processor may also be used to control camera shutter rate. Other camera features and parameters which may be controlled in this manner are compressor resolution ( such as high, medium, low user settings) corresponding to compression rate parameters, field/frame mode, color or monochrome, image spatial resolution (640x420 pixels, 320x240 pixels, for example), lens and camera adjustments, input selection where multiple cameras or video sources are used and the like.

with the following paragraph:

According to embodiments, where [Where] desired, [the] a system also includes camera operation control capability through the use of digital/analog circuits for converting digital commands to analog signals for controlling the gain, pedestal, setup, white clip, lens focus, white balance, lens iris, lens zoom and other functions of the camera from a local input device, a remote device or as automatic or programmed functions. The central processor [may] can also be used to control camera shutter rate. Other camera features and parameters which [may] can be controlled in this manner are compressor resolution ( such as high, medium, low user settings) corresponding to compression rate parameters, field/frame mode, color or monochrome, image spatial resolution (640x420 pixels, 320x240 pixels, for example), lens and camera adjustments, input selection where multiple cameras or video sources are used and the like.

Replace paragraph [0024] which reads:

When an integrated communications device is used, such as by way of example, a cellular telephone, the telephone can be isolated from the rest of the system to permit independent use, and independent power up and power off and other cellular phone functions.

with the following paragraph:

According to embodiments, when [When] an integrated communications device is used, such as by way of example, a cellular telephone, the telephone can be isolated

from the rest of the system to permit independent use, and independent power up and power off and other cellular phone functions.

Replace paragraph [0025] which reads:

In operation, the system permits not only the manual capture, dial (select) and send of images, but may also be fully automated to capture, dial and send, for example, on a timed sequence or in response to a sensor such as a motion sensor, video motion detection, or from a remote trigger device. The remote trigger also may be activated by an incoming telephone signal, for example.

with the following paragraph:

According to embodiments, in [In] operation, [the] a system permits not only the manual capture, dial (select) and send of images, but [may] can also be fully automated to capture, dial and send, for example, on a timed sequence or in response to a sensor such as a motion sensor, video motion detection, or from a remote trigger device. The remote trigger also [may] can be activated by an incoming telephone signal, for example.

Replace paragraph [0026] which reads:

The remote device may also be used for remote loading and downloading of firmware, and for setting of the programmable parameters such as to provide remote

configuration of sampling modes during capture, compression rates, triggering methods and the like.

with the following paragraph:

In embodiments, a [The] remote device [may] can also be used for remote loading and downloading of firmware, and for setting of the programmable parameters such as to provide remote configuration of sampling modes during capture, compression rates, triggering methods and the like.

Replace paragraph [0028] which reads:

Circular sampling techniques are supported by the data capture system of the present invention. This is particularly useful when triggering events are used to initiate transmission of collected image data over the communications system. For example, if a triggering event is motion detected at a motion sensor, it may be useful to look at the images captured for a period of time both prior to and after the actual event. The circuitry of the subject invention permits any circular sampling technique to be utilized depending upon application, such as prior to an after trigger, only after trigger or only before trigger or prior to and after the trigger point. Again, as an example, it may be desirable to look primarily at images captured before a triggering event if the event is a catastrophic event such as an explosion or the like. Other circular sampling techniques may be employed, as well, incorporating multiple cameras, for example, wherein different fields are sampled depending upon the time frame in a sequence of events.

with the following paragraph:

Circular sampling techniques are supported by [the] a data capture system of the present [invention] disclosure. This is particularly useful when triggering events are used to initiate transmission of collected image data over the communications system. For example, if a triggering event is motion detected at a motion sensor, it may be useful to look at the images captured for a period of time both prior to and after the actual event. The circuitry of [the] subject [invention] embodiments permits any circular sampling technique to be utilized depending upon application, such as prior to an after trigger, only after trigger or only before trigger or prior to and after the trigger point. Again, as an example, it [may] can be desirable to look primarily at images captured before a triggering event if the event is a catastrophic event such as an explosion or the like. Other circular sampling techniques [may] can be employed, as well, incorporating multiple cameras, for example, wherein different fields are sampled depending upon the time frame in a sequence of events.

Replace paragraph [0029] which reads:

It is, therefore, an object and feature of the invention to provide an apparatus for capturing, converting and transmitting a visual image via standard facsimile transmissions systems.

with the following paragraph:

~~It is, therefore, an object and feature of the invention to~~ Embodiments provide an apparatus for capturing, converting and transmitting a visual image via standard

facsimile [transmissions] transmission systems.

Replace paragraph [0030] which reads:

It is another object and feature of the invention to provide an apparatus for compressing the visual image data in order to minimize the capacity requirements of the data capture and storage system.

with the following paragraph:

~~It is another object and feature of the invention to~~ Embodiments provide an apparatus for compressing the visual image data in order to minimize the capacity requirements of the data capture and storage system.

Replace paragraph [0031] which reads:

It is an additional object and feature of the invention to provide an apparatus for capturing and storing a visual image for later recall and review and/or transmission.

with the following paragraph:

~~It is an additional object and feature of the invention to~~ Embodiments provide an apparatus for capturing and storing a visual image for later recall and review and/or transmission.

Replace paragraph [0032] which reads:

It is yet another object and feature of the invention to provide an apparatus for storing a captured video image in digital format on a portable storage medium.

with the following paragraph:

~~It is yet another object and feature of the invention to~~ Embodiments provide an apparatus for storing a captured video image in digital format on a portable storage medium.

Replace paragraph [0033] which reads:

It is an additional object and feature of the invention to provide an apparatus capable of sending and receiving telephonic audio messages, facsimile documents, and captured visual images to and from standard, readily available remote stations.

with the following paragraph:

~~It is an additional object and feature of the invention to~~ Embodiments provide an apparatus capable of sending and receiving telephonic audio messages, facsimile documents, and captured visual images to and from standard, readily available remote stations.

Replace paragraph [0034] which reads:

It is a further object and feature of the invention to provide the means and method for capturing images prior to, prior to and after, or after a triggering event.

with the following paragraph:

~~It is a further object and feature of the invention to~~ Embodiments provide the means and method for capturing images prior to, prior to and after, or after a triggering event.

Replace paragraph [0035] which reads:

It is also an object and feature of the invention to provide for triggering events and/or optional viewing or review of the captured images prior to printing or transmission.

with the following paragraph:

~~It is also an object and feature of the invention to~~ Embodiments provide for triggering events and/or optional viewing or review of the captured images prior to printing or transmission.

Replace paragraph [0036] which reads:

It is another object and feature of the invention to provide an apparatus which may be activated from a remote location for initiating the capture of images by the device.



with the following paragraph:

~~It is another object and feature of the invention to~~ Embodiments provide an apparatus which [may] can be activated from a remote location for initiating the capture of images by the device.

Replace paragraph [0047] which reads:

The image capture and transmission system of the subject invention is suited for capturing one or more single frame analog image or a digital image data signal and transmitting the captured signal via any of a plurality of transmission schemes to a remote receiving station where the image is downloaded in a suitable format for viewing and printing on hard paper copy, a CRT screen image, or other medium. The system is particularly well suited for sending and/or receiving images via a standard Group III facsimile transmission system and permits capture of the image at a remote location using an analog or digital camera. Two generic configurations are shown and described, the first, where each image is transmitted as it is captured, and the second, which permits capture, storage, and selective recall of captured images for transmission. The invention also contemplates a portable storage medium, wherein the captured stored medium may be removed from the capture device and archived for later use. While a system for black and white (gray tones) for Group-III facsimile transmission is described in detail herein, the invention could be readily adapted to transmission of color images utilizing the teachings of the present invention using industry standard color video standards and circuits. Both portable, or hand held, and stationary, or desktop, units are described. The circuitry utilized for both configurations is identical , but stationary configurations do not need a battery.

with the following paragraph:

[The] According to embodiments, an image capture and transmission system [of the subject invention is suited for capturing] captures either one or more single frame analog [image] images or digital [image] images or image data or visual data or visual images, the aforementioned hereinafter being referred to as an “image” or “images”, [data signal and transmitting the] and transmits a captured image in a digital signal via any of a plurality of transmission schemes through a transmission interface such as, for example, cellular transmission, radio signal, satellite transmission, hard line telephonic transmission, or other transmission to a remote receiving station where the image is downloaded [in a suitable format] for viewing on a screen or [and] printing on hard paper copy or other medium. [The] According to embodiments, a system is particularly well suited for sending and/or receiving images via a standard Group III facsimile transmission system and permits capture of the image at a remote location using an analog or digital camera. Two generic configurations are shown and described, the first, where each image is transmitted as it is captured, and the second, which permits capture, storage, and selective recall of captured images for transmission. [The invention also contemplates] Embodiments also contemplate a portable storage medium[, wherein] having the captured [stored medium may] images stored thereon and which can be removed from the capture and transmission unit [device] and archived for later use. While a system for black and white (gray tones) for Group-III facsimile transmission is described in detail herein, [the invention could] embodiments can be readily adapted to transmission of color images utilizing the teachings of the present [invention] disclosure using industry standard color video standards and circuits. Both portable, or hand held, image capture and transmission

units and stationary, or desktop, image capture and transmission units are described.

The circuitry utilized for both configurations is identical, but stationary configurations do not need a battery.

Replace paragraph [0049] which reads:

Turning now to Fig. 1, the simplest embodiment of the invention incorporates a standard analog or digital camera device 10 for capturing a visual image in the typical fashion. The camera 10 may be operator activated as indicated at 12, or may be programmed to be activated at selected intervals or in response to certain conditions. For example, a motion detector may be utilized to activate the camera 10 in a surveillance installation. Once activated, the camera 10 captures a visual image in typical fashion through a lens (see lens 192, for example, in Fig. 7A). In the illustrated embodiment, the captured image is then transmitted to a gray scale bit map memory device 16, from which it is output to a half-tone conversion scheme 18 to be input into a binary bit map 20 for formatting the captured image in a configuration suitable for transmission via a Group-III facsimile system. The signal generated at 22 by the binary bit map 20 is input into a Group-III encoding and compression network 24 for generating an output signal at 26 which is introduced into a Group III protocol transmission device 28. The output at 30 of the transmission device 28 is then transmitted into any standard transmission interface such as, by way of example, hard line telephonic transmission, cellular transmission, radio signal, satellite transmission or other transmission system 32 via a modem or similar device, as needed (as diagrammatically illustrated at 29), to be received via a compatible interface by a remote Group-III receiving system 34. The Group III receiving system 34 is a typical Group-III facsimile system comprising a Group-III receiver 36, decoder and

decompressor 38 and binary bit map 40, from which a facsimile hard copy such as plain paper copy 42 may be generated.

with the following paragraph:

Turning now to Fig. 1, [the simplest] an embodiment [of the invention] incorporates an image capture device such as a standard analog or digital camera device 10 for capturing a visual image in the typical fashion. The camera 10 [may] can be operator activated as indicated at 12, or [may] can be programmed to be activated at selected intervals or in response to certain conditions. For example, a motion detector [may] can be utilized to activate the camera 10 in a surveillance installation. Once activated, the camera 10 captures a visual image in typical fashion through a lens (see lens 192, for example, in Fig. 7A). In the illustrated embodiment, the captured image is then transmitted to a gray scale bit map memory device 16, from which it is output to a half-tone conversion scheme 18 to be input into a binary bit map 20 for formatting the captured image in a configuration suitable for transmission via a Group-III facsimile system. The signal generated at 22 by the binary bit map 20 is input into a Group-III encoding and compression network 24 for generating an output signal at 26 which is introduced into a Group III protocol transmission device 28. The output at 30 of the transmission device 28 is then transmitted into any standard transmission interface such as, by way of example, hard line telephonic transmission, cellular transmission, radio signal, satellite transmission or other transmission system 32 via a modem or similar device, as needed (as diagrammatically illustrated at 29), to be received via a compatible interface by a remote Group-III receiving system 34. The Group III receiving system 34 is a typical Group-III facsimile system comprising a Group-III receiver 36, decoder and decompressor 38 and binary bit map 40, from which a

facsimile hard copy such as plain paper copy 42 [may] can be generated.

Replace paragraph [0050] which reads:

This configuration is particularly well suited where real near time transmission is desired, for example when the system is operator controlled and a “real time” image is desired at a remote location. An example of such a system may be a photo identification confirmation of an apprehended suspect in law enforcement use, or transmission of images of damaged assets for insurance purposes, or transmission of images of construction job site conditions. This configuration is also well suited for use in those applications where a sensor activates the system and real time transmission of the sensed condition is desired. An example of such a system would be a motion activated camera in a surveillance location, where the image is immediately transmitted to a remote monitoring station. Of course, it will be readily understood by those who are skilled in the art that tagging a transmitted image with information such as, by way of example, date, time and location, can be incorporated in the transmitted signal so that a receiving station could monitor a plurality of remote image data capture systems. This is also useful for reviewing a body of previously stored or printed images to determine the time and location of such image.

with the following paragraph:

[This] According to an embodiment, the above-described configuration is particularly well suited where [real] near real time transmission is desired, for example when the system is operator controlled and a “real time” image is desired at a remote location. An example of such a system [may] can be a photo identification confirmation of an

apprehended suspect in law enforcement use, or transmission of images of damaged assets for insurance purposes, or transmission of images of construction job site conditions. This configuration is also well suited for use in those applications where a sensor activates the system and real time transmission of the sensed condition is desired. An example of such a system would be a motion activated camera in a surveillance location, where the image is immediately transmitted to a remote monitoring station. Of course, it will be readily understood by those who are skilled in the art that tagging a transmitted image with information such as, by way of example, date, time and location, can be incorporated in the transmitted signal so that a receiving station could monitor a plurality of remote image data capture systems. This is also useful for reviewing a body of previously stored or printed images to determine the time and location of such image.

Replace paragraph [0051] which reads:

The embodiment of Fig. 2 is similar to Fig. 1, but incorporates a memory and optional operator viewer system. The image is captured by the camera 10 and conditioned by the gray scale bit map 16, as in Fig. 1. In this embodiment, the output 44 of the bit map 16 is input into a standard digital memory device 46 for later recall. This configuration is particularly well suited for applications where near real time transmission of the image either is not required or is not desirable. It will be noted that with the exception of the insertion of the memory device 46 and the optional viewer device 48, the capture and transmission system of Fig. 2 is identical to that shown and described in Fig. 1. Once the image is captured by the camera 10 and is presented at 44 to the memory device 46, it is stored for later recall and transmission. The specific type of memory device is optional and may include, for example, an SRAM device, a

DRAM, Flash RAM, hard drive, floppy disk, PCMCIA format removable memory (see, for example, the PCMCIA card 50 in Fig. 7A), writeable optical media or other storage device. The memory may selectively capture images, as indicated by the operator interface/capture interface 52, or may be programmed to selectively capture periodic images or all images. In the embodiment shown in Fig. 2, an optional viewer device 48 is provided. This permits the operator to recall and view all or selective images before transmission, as indicated by the operator interface/recall interface 54. This permits the operator to review all images retained in the memory 46 and transmit selective images, as desired, to the Group-III transmission system. The remainder of the system of Fig. 2 operates in the same manner as the configuration shown and described in Fig. 1.

with the following paragraph:

The embodiment of Fig. 2 is similar to Fig. 1, but incorporates a memory and optional operator viewer system. The image is captured by the camera 10 and conditioned by the gray scale bit map 16, as in Fig. 1. In this embodiment, the output 44 of the bit map 16 is input into a standard digital memory device 46 for later recall. This configuration is particularly well suited for applications where near real time transmission of the image either is not required or is not desirable. It will be noted that with the exception of the insertion of the memory device 46 and the optional viewer device 48, the capture and transmission system of Fig. 2 is identical to that shown and described in Fig. 1. Once the image is captured by the camera 10 and is presented at 44 to the memory device 46, [it] the image is stored for later recall and transmission. The specific type of memory device is optional and [may] can include, for example, an SRAM device, a DRAM, Flash RAM, hard drive, floppy disk, PCMCIA format

removable memory (see, for example, the PCMCIA card 50 in Fig. 7A), writeable optical media or other storage device. The memory [may] can selectively capture images, as indicated by the operator interface/capture interface 52, or [may] can be programmed to selectively capture periodic images or all images. In the embodiment shown in Fig. 2, an optional viewer device 48 is provided[. This] and permits the operator to recall and view all or selective images before transmission, as indicated by the operator interface/recall interface 54. [This] The optional viewer device 48 permits the operator to review all images retained in the memory 46 and transmit selective images, as desired, to the Group-III transmission system. The remainder of the system of Fig. 2 operates in the same manner as the configuration shown and described in Fig. 1.

Replace paragraph [0052] which reads:

The configuration of Fig. 3 incorporates all of the features of Figs. 1 and 2, and additionally, includes an interim data compression and decompression scheme to permit increased utilization of the memory or storage medium 46. As shown in Fig. 3, an interim format compressor 56 is inserted between the gray scale bit map 16 and the memory device 46. This permits compression and reduction of the data required to store the image, effectively increasing the capacity of the storage device. It is an objective of the storage device to preserve the gray scale quality of the image for viewing at the location of capture. An interim format decompression device 58 is inserted between the output of the memory device 46 and the rest of the system, whether the optional viewer 48 is utilized, or the output is entered directly into the half-tone convertor 18. The interim compression/decompression scheme is particularly useful when all of the image data is to be permanently archived, or when



limited capacity portable media are used, such as, by way of example, floppy disks or a portable PCMCIA card. It will be noted that the remainder of the system shown in Fig. 3 is identical to the system shown and described in Fig. 2.

with the following paragraph:

The configuration of Fig. 3 incorporates all of the features of Figs. 1 and 2, and additionally, includes an interim data compression and decompression scheme to permit increased utilization of the memory or storage medium 46. As shown in Fig. 3, an interim format compressor 56 is inserted between the gray scale bit map 16 and the memory device 46. [This] Insertion of the interim format compressor 56 between the gray scale bit map 16 and the memory device 46 permits compression and reduction of the data required to store the image, effectively increasing the capacity of the storage device or storage medium 46. [It is an objective of] Embodiments including the storage device or storage medium 46 can [to] preserve the gray scale quality of the image for viewing at the location of capture. An interim format decompression device 58 is inserted between the output of the memory device or storage medium 46 and the rest of the system, whether the optional viewer 48 is utilized, or the output is entered directly into the half-tone convertor 18. The interim compression/decompression scheme is particularly useful when all of the image data is to be permanently archived, or when limited capacity portable media are used, such as, by way of example, floppy disks or a portable PCMCIA card. It will be noted that the remainder of the system shown in Fig. 3 is identical to the system shown and described in Fig. 2.

Replace paragraph [0053] which reads:

Fig. 4 illustrates the use of the image capture and/or retention configured in any of the

optional embodiments of Figs. 1-3 and adapted for use in combination with any of a variety of transmitting and receiving schemes such as, by way of example, the Group-III system shown in Figs. 1-3, a modem, direct connection to a personal computer, serial or parallel transmission, or any selected transmitting/receiving protocol. This illustration demonstrates the versatility of the system once the image has been captured, converted and conditioned by the image capture device of the subject invention. Specifically, once the image is captured by the camera 10 and conditioned by the gray scale bit map 16, it may be stored and transmitted, or transmitted "real time" via any transmitting and receiving scheme. As shown in Fig. 4 the image capture device includes the memory device 46 and the optional viewer 48 for incorporating maximum capability. However, any of the schemes of Figs. 1-3 would be suitable for producing a transmittable signal. In the embodiment shown, a format select interface switch 60 is positioned to receive the fully conditioned signal on line 59. This would permit either automated or manual selection of the transmitting protocol, including the Group-III facsimile system previously described in connection with Figs. 1-3, as indicated by selecting format select switch 60 position A; or PC modem protocol as illustrated by the JPEG compressor 62 and protocol generator 64, as indicated by selecting format select switch position B; or the wavelet compressor and PC modem protocol, as illustrated by the wavelet compressor 66 and PC modem protocol generator 68 by selecting switch position C; or any selected conversion network 65, (if needed) with a compatible compressor 67 (if needed) and compatible protocol generator 75 (if needed), as indicated by switch position D; or a serial protocol scheme 77, with serial drivers 79 directly to a hardwired personal computer 81 by selecting switch position E. Of course, it will be readily understood by those skilled in the art that one or a plurality of transmitting protocols may be simultaneously selected. Depending on the protocol selected, the signal output is

generated at the selected output module and introduced to a communications interface module 83 via a modem or other device, as needed, for transmission via a transmission system to a compatible receiving station such as the Group-III facsimile device 34, the personal computer 85, the video telephone 89, and/or other server or receiving device 91 for distribution.

with the following paragraph:

Fig. 4 illustrates the use of the image capture and/or retention configured in any of the optional embodiments of Figs. 1-3 and adapted for use in combination with any of a variety of transmitting and receiving schemes such as, by way of example, the Group-III system shown in Figs. 1-3, a modem, direct connection to a personal computer, serial or parallel transmission, or any selected transmitting/receiving protocol. This illustration demonstrates the versatility of [the] a system according to embodiments once the image has been captured, converted and conditioned by the image capture device of the [subject invention] disclosure. Specifically, once the image is captured by the camera 10 and conditioned by the gray scale bit map 16, it [may] can be stored and transmitted, or transmitted “near real time” via any transmitting and receiving scheme. As shown in Fig. 4 the image capture device includes the memory device 46 and the optional viewer 48 for incorporating maximum capability. However, any of the schemes of Figs. 1-3 would be suitable for producing a transmittable signal. In the embodiment shown, a format select interface switch 60 is positioned to receive the fully conditioned signal on line 59. [This would] The format select interface switch 60 can permit either automated or manual selection of the transmitting protocol, including the Group-III facsimile system previously described in connection with Figs. 1-3, as indicated by selecting format select switch 60 position A; or PC modem

protocol as illustrated by the JPEG compressor 62 and protocol generator 64, as indicated by selecting format select switch position B; or the wavelet compressor and PC modem protocol, as illustrated by the wavelet compressor 66 and PC modem protocol generator 68 by selecting switch position C; or any selected conversion network 65, (if needed) with a compatible compressor 67 (if needed) and compatible protocol generator 75 (if needed), as indicated by switch position D; or a serial protocol scheme 77, with serial drivers 79 directly to a hardwired personal computer 81 by selecting switch position E. Of course, it will be readily understood by those skilled in the art that one or a plurality of transmitting protocols [may] can be simultaneously selected. Depending on the protocol selected, the signal output is generated at the selected output module and introduced to a communications interface module 83 via a modem or other device, as needed, for transmission via a transmission system to a compatible receiving station such as the Group-III facsimile device 34, the personal computer 85, the video telephone 89, and/or other server or receiving device 91 for distribution.

Replace paragraph [0054] which reads:

An exemplary circuit supporting the configurations of Figs. 1-4 is shown in Fig. 5. With specific reference to Fig. 5, an analog camera is indicated by the “video in” signal at 70. Typically, the video signal is a composite video/sync signal. The diagram shows all of the signal processing necessary to sync up to an NTSC signal 70 coming out of the analog camera and processed for introduction into an integral RAM memory 71 and/or a portable RAM memory via interface 73. An analog to digital (A/D) converter 74 converts the video portion of the analog signal from the camera and produces the digital signal for output at line 76. The digital output data on path 76

is introduced into a data multiplexer circuit 81 and into the RAM memory unit(s) 71, 72. In the exemplary embodiment, the portable RAM memory 72 is an image card such as, by way of example, a PCMCIA SRAM card or a PCMCIA Flash RAM card. However, it will be readily understood that any suitable RAM memory configuration can be used within the teachings of the invention. It is desirable to store compressed rather than raw data in card 72 because of space and transmission speed factors.

with the following paragraph:

According to embodiments, an [An] exemplary circuit supporting the configurations of Figs. 1-4 is shown in Fig. 5. With specific reference to Fig. 5, an analog camera is indicated by the “video in” signal at 70. Typically, the video signal is a composite video/sync signal. The diagram shows all of the signal processing necessary to sync up to an NTSC signal 70 coming out of the analog camera and processed for introduction into an integral RAM memory 71 and/or a portable RAM memory via interface 73. An analog to digital (A/D) converter 74 converts the video portion of the analog signal from the camera and produces the digital signal for output at line 76. The digital output data on path 76 is introduced into a data multiplexer circuit 81 and into the RAM memory unit(s) 71, 72. In the exemplary embodiment, the portable RAM memory 72 is an image card such as, by way of example, a PCMCIA SRAM card or a PCMCIA Flash RAM card. However, it will be readily understood that any suitable RAM memory configuration can be used within the teachings of the [invention] disclosure. In an embodiment, it [It] is desirable to store compressed rather than raw data in portable memory card 72 because of space and transmission speed factors.

Replace paragraph [0056] which reads:

This frame may now be output from the system via any of the available transmitting schemes. In the exemplary embodiment, the processor 86 may be any processor or such as a microprocessor or DSP, with sufficient capability to perform the described functions. The processor bus is indicated at 87. The circuitry supporting the processor comprises the processor chip 86 and the control store memory (ROM, Flash RAM, PROM, EPROM or the like) 92 for storing the software program executed by the processor. It will be understood that other memory devices could be utilized without departing from the spirit of the invention. For example, a Flash RAM would permit flexibility and replacement of the program for upgrades and enhancements. The user interface commands are generated and interpreted by the software that is being executed by the processor 86.

with the following paragraph:

This frame [may] can now be output from the system via any of the available transmitting schemes. In the exemplary embodiment, the processor 86 [may] can be any processor or such as a microprocessor or DSP, with sufficient capability to perform the described functions. The processor bus is indicated at 87. The circuitry supporting the processor comprises the processor chip 86 and the control store memory (ROM, Flash RAM, PROM, EPROM or the like) 92 for storing the software program executed by the processor. It will be understood that other memory devices [could] can be utilized without departing from the [spirit of] the [invention] disclosure. For example, a Flash RAM [would] can permit flexibility and replacement of the program for upgrades and enhancements. The user interface

commands are generated and interpreted by the software that is being executed by the processor 86.

Replace paragraph [0057] which reads:

The display unit 94 is connected through a typical interface 96, and provides visual user interface at the camera body to give the operator a visual read-out of the status of the collection and transmission of a selected frame. In the exemplary embodiment, the display unit is a two line, multi-character LCD display, but other sizes or technology displays could be readily incorporated, depending, for example, on the amount of graphics desired in the display module. The bank of operator buttons and/or switches 98 are connected to the system through the button interface 100.

with the following paragraph:

The display unit [94] 96 is connected through a typical interface [96] 94, and provides a visual user interface at the camera body to give the operator a visual read-out of the status of the collection and transmission of a selected frame. In [the] an exemplary embodiment, the display unit is a two line, multi-character LCD display, but other sizes or technology displays could be readily incorporated, depending, for example, on the amount of graphics desired in the display module. The bank of operator buttons and/or switches 98 are connected to the system through the button interface 100.

Replace paragraph [0062] which reads:

The system of the present invention also contemplates wireless transmission over a cellular telephone, radio frequency, satellite transmission or the like. In the exemplary embodiment, the specific configuration for a cellular telephone interface is shown in detail. The amplifiers 122, 124 amplify the input of the modem 104 and are controlled by the FETs 126, 128, respectively. The FETs are controlled by the control register 102 and allow selection of the audio either coming in from the cellular interface 130 or from the telephone line 104 to the modem. This permits the cellular phone to be used for three distinct functions: (1) as an audio telephone, (2) as a transmitting system for transmitting the captured image and related signals via a cellular system, and (3) for receiving incoming transmissions to the processor such as remote control, remote configuration, or images.

with the following paragraph:

[The] A system of the present [invention] disclosure also contemplates wireless transmission over a cellular telephone, radio frequency, satellite transmission or the like. In [the] an exemplary embodiment, the specific configuration for a cellular telephone interface is shown in detail. The amplifiers 122, 124 amplify the input of the modem 104 and are controlled by the FETs 126, 128, respectively. The FETs are controlled by the control register 102 and allow selection of the audio either coming in from the cellular interface 130 or from the telephone line 104 to the modem. This permits the cellular phone to be used for three distinct functions: (1) as an audio telephone, (2) as a transmitting system for transmitting the captured image and related signals via a cellular system, and (3) for receiving incoming transmissions to the processor such as remote control, remote configuration, or images.



Replace paragraph [0067] which reads:

Various physical configurations of the invention are shown in Figs.7A & 7B. Figs. 6A, 6B and 6C are block diagrams for desktop and portable units. Figs. 7A and 7B illustrate the subject invention as incorporated in a standard 35 millimeter type camera housing.

with the following paragraph:

Various physical configurations of [the invention] embodiments are shown in Figs.7A & 7B. Figs. 6A, 6B and 6C are block diagrams for desktop and portable units. Figs. 7A and 7B illustrate [the subject invention] embodiments as incorporated in a standard 35 millimeter type camera housing.

Replace paragraph [0068] which reads:

A basic desktop system is shown in Fig. 6A, and includes a console unit having a telephone jack 152, an external telephone connection 154 and a video input/camera power jack 156 for connecting the analog camera 10. A facsimile machine may be also connected at jack 154 to provide local printer capability. The configuration shown in Fig. 6B is a basic portable system, with a battery powered portable module 160 having a self-contained power source 162. The system may include an integral RAM and/or the removable memory module as indicated by the image card 72. The camera 10 may be an integral feature of the portable module 160, or may be a detached unit, as desired. In this embodiment, a cellular telephone 164 is provided with a datajack 166 for connecting to the output jack 168 of the module, whereby the image data signal may be transmitted via the cellular telephone to a remote facsimile

machine over standard cellular and telephone company facilities. When incorporating the circuitry of Fig. 5, the cellular phone may be used as both an input and an output device, and incoming data or stored images may be viewed through the viewfinder 170.

with the following paragraph:

A basic desktop system according to embodiments is shown in Fig. 6A, and includes a console unit having a telephone jack 152, an external telephone connection 154 and a video input/camera power jack 156 for connecting the analog camera 10. A facsimile machine [may be also] can also be connected at jack 154 to provide local printer capability. The configuration shown in Fig. 6B is a basic portable system, with a battery powered portable module 160 having a self-contained power source 162. The system [may] can include an integral RAM and/or the removable memory module as indicated by the image card 72. The camera 10 [may] can be an integral feature of the portable module 160, or [may] can be a detached unit, as desired. In [this] the illustrated embodiment, a cellular telephone 164 is provided with a data jack 166 for connecting to the output jack 168 of the module, whereby the image data signal [may] can be transmitted via the cellular telephone to a remote facsimile machine over standard cellular and telephone company facilities. When incorporating the circuitry of Fig. 5, the cellular phone [may] can be used as both an input and an output device, and incoming data or stored images [may] can be viewed through the viewfinder 170.

Replace paragraph [0070] which reads:

Turning now to Figs. 7A and 7B, the camera body 190 is similar to a standard 35

millimeter camera housing and is adapted to receive a standard lens 192 with a viewfinder 194. The electronics are housed in the casing in the area normally occupied by the film and film advancing implements. The operator interface button keys 98 are housed within the housing and may be positioned on the back plate 196 of the body. Fig. 8. The LCD unit may be positioned to be visible through the viewfinder 194 or may be in a separate back window 198. The memory card 72 is positioned in a slot 200 provided in a sidewall of the camera body. This camera has the appearance of a standard SLR 35 millimeter camera. In addition, where desired, an integral cellular phone can be incorporated in the camera housing and transmission can be sent directly from the camera housing to a remote receiving station. The keypad for the telephone is indicated at 202.

with the following paragraph:

[Turning now to] According to an embodiment illustrated in Figs. 7A and 7B, the camera body 190 is similar to a standard 35 millimeter camera housing and is adapted to receive a standard lens 192 with a viewfinder 194. The electronics are housed in the casing in the area normally occupied by the film and film advancing implements. The operator interface button keys 98 are housed within the housing and [may] can be positioned on the back plate 196 of the body. [Fig. 8.] The LCD unit [may] can be positioned to be visible through the viewfinder 194 or [may] can be in a separate back window 198. The memory card 72 is positioned in a slot 200 provided in a sidewall of the camera body. [This] In the illustrated embodiment, camera body 190 has the appearance of a standard SLR 35 millimeter camera. In addition, where desired, an integral cellular phone can be incorporated in the camera housing and transmission can be sent directly from the camera housing to a remote receiving station. The keypad for the telephone is indicated at 202.

Replace paragraph [0071] which reads:

Fig. 8 is an illustration of an exemplary schematic diagram for the circuit of a system according to the teaching of the invention as specifically taught in the diagram of Fig. 5. Pin numbers, wiring harnesses and components are as shown on the drawing. Fig. 8, part A, is the system interconnect and shows the central processor board 300, the video board 302, the power board 304 and the CRT electronic interconnect board 306. The telephone interface is provided at 307. Board 308 is the audio connector board. Board 310 is the serial connector board and board 312 is the video connector board. Fig. 8, part B contains the audio logic, with audio I/O at 314. The audio amplifiers are designated 316 and 318. A microphone connector is provided at 320, with preamplifier circuit 322. Audio switches are provided at 324 and 326. Summing circuit 328 provides audio summing. The serial RAM for audio is designated 330. Fig. 8, part C includes the camera module 332 and the camera control digital to analog convertor 334. Amplifier 336 is the video buffer. Module 338 is the camera shutter control resistor.

with the following paragraph:

Fig. 8 is an illustration of an exemplary schematic diagram for the circuit of a system according to [the teaching of the invention] embodiments as specifically taught in the diagram of Fig. 5. Pin numbers, wiring harnesses and components are as shown on the drawing. Fig. 8, part A, is the system interconnect and shows the central processor board 300, the video board 302, the power board 304 and the CRT electronic interconnect board 306. The telephone interface is provided at 307. Board

308 is the audio connector board. Board 310 is the serial connector board and board 312 is the video connector board. Fig. 8, part B contains the audio logic, with audio I/O at 314. The audio amplifiers are designated 316 and 318. A microphone connector is provided at 320, with preamplifier circuit 322. Audio switches are provided at 324 and 326. Summing circuit 328 provides audio summing. The serial RAM for audio is designated 330. Fig. 8, part C includes the camera module 332 and the camera control digital to analog convertor 334. Amplifier 336 is the video buffer. Module 338 is the camera shutter control resistor.

Replace paragraph [0080] which reads:

The circuitry supports any of the preferred configurations from a basic real time transmission system via Group-III fax to a comprehensive system supporting both land line and wireless transmission of image, audio and documentary data at both a local and remote station.

with the following paragraph:

The circuitry supports any of the [preferred] configurations [from] such as, for example, a basic near real time transmission system via Group-III fax [to] or a comprehensive system supporting both land line and wireless transmission of image, audio and documentary data at both a local and remote station.

Replace paragraph [0081] which reads:

The subject invention also permits digitized collection of audio signals through the

use of an internal microphone, and external input device, a cellular telephone, land line telephone, wireless radio or other communication system, and digitized audio playback, as well. The playback can be via an internal speaker, out an external out jack to a remote device or via a cellular telephone, land line telephone, wireless radio or other communication system.

with the following paragraph:

~~The subject invention also permits~~ Embodiments permit digitized collection of audio signals through the use of an internal microphone, and external input device, a cellular telephone, land line telephone, wireless radio or other communication system, and digitized audio playback, as well. The playback can be via an internal speaker, out an external out jack to a remote device or via a cellular telephone, land line telephone, wireless radio or other communication system.

Replace paragraph [0083] which reads:

It is an important feature of the invention that the system supports storage of images in an interim storage format including raw video, interim gray scale format and/or half tone format. The image can also be stored in the selected output mode, such as by way of example, a Group III facsimile mode. The versatile capability of the system permits transmission of captured data to a standard bi-level facsimile machine such as Group III, to gray scale facsimile systems or full color facsimile systems, as well as to other remote receiving devices such as, by way of example, personal computers and network servers. The data may be transferred in any of a variety of formats and protocols including JPEG, FAX, emerging imagery formats, wavelets and data

protocols. The invention is adapted to operate in multiple modes, with a unitary capture and send mode or separate capture and store, and send modes. In the preferred embodiment, the system is adapted for tagging a collected image, video, audio, and other data such as a GPS signal, with a real time clock and added text. This permits the complete historical data to be transmitted simultaneously with the image signal.

with the following paragraph:

~~It is an important feature of the invention that the~~ According to embodiments, a system supports storage of images in an interim storage format including raw video, interim gray scale format and/or half tone format. The image can also be stored in the selected output mode, such as by way of example, a Group III facsimile mode. The versatile capability of the system permits transmission of captured data to a standard bi-level facsimile machine such as Group III, to gray scale facsimile systems or full color facsimile systems, as well as to other remote receiving devices such as, by way of example, personal computers and network servers. The data [may] can be transferred in any of a variety of formats and protocols including JPEG, FAX, emerging imagery formats, wavelets and data protocols. [The invention is] Embodiments are adapted to operate in multiple modes, with a unitary capture and send mode or separate capture and store, and send modes. In [the preferred] an embodiment, the system is adapted for tagging a collected image, video, audio, and other data such as a GPS signal, with a real time clock and added text. This permits [the] complete historical data to be transmitted simultaneously with the image signal.

Replace paragraph [0084] which reads:

It is contemplated that the system of the invention would be self-contained with an integral power unit such as a rechargeable battery source or the like. Therefore, the system is adapted to power up when in use and power down when not activated, preserving power during idle time. The power systems for the video camera, the video input circuits and converters, the modem or other transmission devices and other high drain components may be isolated and only powered when needed. This also permits use of ancillary functions, such as use as a cellular telephone, to proceed without draining the power source by powering idle components. The processor clock rate may also be slowed down during idle mode to further conserve power.

with the following paragraph:

It is contemplated that [the] a system according to embodiments [of the invention would] can be self-contained with an integral power unit such as a rechargeable battery source or the like. Therefore, the system [is] can be adapted to power up when in use and power down when not activated, preserving power during idle time. The power systems for the video camera, the video input circuits and converters, the modem or other transmission devices and other high drain components [may] can be isolated and only powered when needed. This also permits use of ancillary functions, such as use as a cellular telephone, to proceed without draining the power source by powering idle components. The processor clock rate [may] can also be slowed down during idle mode to further conserve power.

Replace paragraph [0085] which reads:



Where desired, the system also includes camera operation control capability through the use of a digital/analog network for converting digital commands to analog signals for controlling the gain, pedestal, setup, white clip, lens focus, and other functions of the camera from a local input device, a remote device or as programmed functions. The central processor may also be used to control camera shutter rather camera features and parameters which may be controlled in this manner are compressor resolution (high, medium, low), field/frame mode, color or monochrome, image spatial resolution (640x430, 320x240, for example), lens and camera adjustments, input selection where multiple cameras are used and the like.

with the following paragraph:

Where desired, [the] a system according to embodiments also includes camera operation control capability through the use of a digital/analog network for converting digital commands to analog signals for controlling the gain, pedestal, setup, white clip, lens focus, and other functions of the camera from a local input device, a remote device or as programmed functions. The central processor [may] can also be used to control camera shutter. [rather camera] Camera features and parameters which [may] can be controlled in this manner are compressor resolution (high, medium, low), field/frame mode, color or monochrome, image spatial resolution (640x430, 320x240, for example), lens and camera adjustments, input selection where multiple cameras are used and the like.

Replace paragraph [0087] which reads:

In operation, the system permits not only the manual capture, dial (select) and send of

images, but may also be fully automated to capture, dial and send, for example, on a timed sequence or in response to a sensor such as a motion sensor or from a remote trigger device. The remote trigger may be activated by an incoming telephone signal, for example. The remote device may also be use for remote loading and downloading of firmware, and of the programmable devices, as well as to provide remote configuration of sampling modes during both the capture and the send functions.

with the following paragraph:

In operation, [the system] a system according to embodiments permits [not only] the manual capture, dial (select) and send of images, [but may] and can also be fully automated to capture, dial and send, for example, on a timed sequence or in response to a sensor such as a motion sensor or from a remote trigger device. The remote trigger [may] can be activated by an incoming telephone signal, for example. The remote device [may] can also be use for remote loading and downloading of firmware, and of the programmable devices, as well as to provide remote configuration of sampling modes during both the capture and the send functions.

Replace paragraph [0088] which reads:

Circular sampling techniques are supported by the data capture system of the present invention. Fig. 9 is a diagram illustrating exemplary sampling techniques in accordance with the teachings of the invention. As shown in Fig. 9, the time sequence is indicated by the Time Line:  $t_1, t_2, \dots, t_n$ , with a sample at each time interval, as indicated by  $S_1, \dots, S_n$ . For purposes of illustration, the triggering event occurs at time interval  $t_{10}$ . Based on the predetermined programming of the system, images will

start to be collected upon triggering event, as shown at 210, for a predetermined period prior to and after trigger, as shown at 212, or immediately preceding the trigger, as shown at 214. This permits “circular image storage” without requiring that all images be collected and stored in order to look at events surrounding a triggering event. The technique is also very useful when multiple overlapping zones are monitored by multiple devices and it is desirable to sequence from device to device without losing any critical images.

with the following paragraph:

Circular sampling techniques are supported by [the] a data capture system according to embodiments [of the present invention]. Fig. 9 is a diagram illustrating exemplary sampling techniques in accordance with the teachings of the [invention] disclosure. As shown in Fig. 9, the time sequence is indicated by the Time Line: t1, t2.. .tn, with a sample at each time interval, as indicated by S1... Sn. For purposes of illustration, the triggering event occurs at time interval t10. Based on the predetermined programming of the system, images will start to be collected upon triggering event, as shown at 210, for a predetermined period prior to and after trigger, as shown at 212, or immediately preceding the trigger, as shown at 214. This permits “circular image storage” without requiring that all images be collected and stored in order to look at events surrounding a triggering event. [The technique is] Circular sampling techniques are also very useful when multiple overlapping zones are monitored by multiple devices and it is desirable to sequence from device to device without losing any critical images.

Replace paragraph [0089] which reads:

This is particularly useful when triggering events are used to initiate transmission of collected image data over the communications system. For example, if a triggering event is motion detected at a motion sensor, it may be useful to look at the images captured for a period of time both prior to and after the actual event. The circuitry of the subject invention permits any circular sampling technique to be utilized depending upon application, such as prior to an after trigger, only after trigger or only before trigger. Again, as an example, it may desirable to look primarily at images captured before a triggering event if the event is a catastrophic event such as an explosion or the like. Other circular sampling techniques may be employed, as well, incorporating multiple cameras, for example, wherein different fields are sampled depending upon the time frame in a sequence of events.

with the following paragraph:

[This is] Circular sampling techniques are particularly useful when triggering events are used to initiate transmission of collected image data over the communications system. For example, if a triggering event is motion detected at a motion sensor, it may be useful to look at the images captured for a period of time both prior to and after the actual event. The circuitry of [the subject invention] embodiments permits any circular sampling technique to be utilized depending upon application, such as prior to an after trigger, only after trigger or only before trigger. Again, as an example, it [may] can be desirable to look primarily at images captured before a triggering event, if the event is a catastrophic event such as an explosion or the like. Other circular sampling techniques [may] can be employed, as well, incorporating multiple cameras, for example, wherein different fields are sampled depending upon the time frame in a sequence of events.

Replace paragraph [0090] which reads:

Other configurations are contemplated and are within the teachings of the invention. While specific embodiments have been shown and described herein, it will be understood that the invention includes all modifications and enhancements within the scope and spirit of the claims.

with the following paragraph:

Other configurations are contemplated and are within the teachings of the [invention] disclosure. While specific embodiments have been shown and described herein, it will be understood that the invention includes all modifications and enhancements within the scope and spirit of the claims.

**Amendments to Claims:**

This listing of claims will replace all prior versions, and listings, of claims in the application.

**Listing of Claims:**

1-42. (Cancelled)

43. (currently amended) A handheld self-contained cellular telephone and integrated image processing system [both of which are carried in a common case] for both sending and receiving telephonic audio signals and for capturing a visual image and transmitting it to a compatible remote receiving station, the system comprising:

[a. A] a manually portable housing [defining the common case];

[b. An] an integral image capture device comprising an electronic camera contained within the portable housing;

[c. A] a display for displaying an image framed by the camera, the display being supported by the housing, the display and the electronic camera being commonly movable in the housing when the housing is moved by hand;

[d. A] a processor in the housing for generating an image data signal representing the image framed by the camera;

[e. A] a memory associated with the processor for collecting and storing the image data signal;

[f. A] a user interface for enabling a user to select the image data signal for viewing and transmission;

[g. A] a telephonic system in the housing for sending and receiving digitized audio signals and for sending the image data signal;

[h. Alphanumeric] alphanumeric input keys in the housing for permitting manually

input digitized alphanumeric signals to be input to the processor, the telephonic system further used for sending the digitized alphanumeric signals;

[i. A] a wireless communications device adapted for transmitting any of the digitized signals to the compatible remote receiving station; and

[j. A] a power supply for powering the system.

44. (currently amended) The self-contained cellular telephone and integrated image processing system of Claim 43, wherein the display for framing the image to be captured by the image capture device [displays] is operable to display the image at the system whereby the image can be viewed and framed prior to capture in the memory.

45. (currently amended) The self-contained cellular telephone and integrated image processing system of Claim 43, wherein the display is [used] operable to display for viewing alphanumeric messages input at the alphanumeric keys.

46. (Cancelled)

47. (Cancelled)

48. (currently amended) The self-contained cellular telephone and integrated image processing system of Claim 43, further comprising a removable memory module in addition to the memory, said removable memory able to be removably housed in the housing for storing captured image data signals.

49. (Cancelled)

50. (currently amended) The self-contained cellular telephone and integrated image processing system of Claim 43, wherein the display is [used] operable to display for viewing incoming image data signals.



51. (currently amended) A handheld cellular telephone having an integrated electronic camera [in a common case] for both sending and receiving telephonic audio signals and for capturing a visual image, converting the visual image to a digitized image data signal and transmitting digitized image data signal via a cellular telephone network, the cellular telephone comprising:

[a. A] a manually portable housing [defining the common case] supporting the cellular telephone and the integrated electronic camera, the cellular telephone and the integrated electronic camera being movable in common with the housing;

[b. A] a cellular telephone in the housing, the cellular telephone further including a transmitter/receiver for transmitting and receiving audio telephone messages over a cellular telephone network, a keypad for entering manually input alphanumeric signals to be transmitted over the cellular telephone network, and a display window for viewing the manually input alphanumeric signals;

[c. An] an integral electronic camera in the housing, the camera for visually framing a visual image to be captured;

[d. A] a processor associated with the electronic camera for capturing and digitizing the framed image in a format for transmission over the cellular telephone network via the cellular telephone;

[e. A] a memory associated with the processor for receiving and storing the digitized framed image;

[f. A] a user interface for enabling a user to selectively display the digitized framed image in the display window and subsequently transmit [it] the digitized framed image over the cellular telephone network; and

[g. An] an integrated power supply for powering both the cellular telephone and the camera.

52. (currently amended) The handheld cellular telephone of Claim 51, wherein the display window for viewing the alphanumeric signals is within the display window for framing the visual image.

53. (Cancelled)

54. (currently amended) The handheld cellular telephone of Claim 51, further including a second memory selectively removable from the housing.

55. (currently amended) A combination of handheld cellular telephone and electronic camera [in a unitary case] comprising:

[a. A] a housing [defining the case];

[b. A] an electronic camera integral within the housing;

[c. A] a display in the housing for framing the image to be captured by an image capture device and for viewing the image, whereby an operator can view and frame the image prior to capture;

[d. A] a processor for processing the image framed by the camera for generating a digitized framed image as displayed in the display;

[e. A] a memory associated with the processor for receiving and storing the digitized framed image for selectively displaying [it] the digitized framed image in the display window and for selectively transmitting [it] the digitized framed image over a cellular telephone network;

[f. A] a cellular telephone in the housing for accepting and digitizing audio signals to be transmitted and for converting received digitized audio signals into acoustic audio, the cellular telephone further for transmitting and receiving non-audio digital signals including digitized image signals;

[g. Alphanumeric] alphanumeric input keys in the housing for permitting manually input alphanumeric signals to be input into the cellular telephone, the manually input alphanumeric signals being presented in the display;

[h. A] a power supply in the housing for powering the processor, the cellular telephone, the display and the camera;

[i. A] a wireless transmitter/receiver in the housing for transmitting digital signals sent from and receiving digital signals sent to the cellular telephone; and

[j. camera operation control capability through the use of ] digital/analog circuits for converting digital commands to analog signals for controlling gain, pedestal, setup,

white clip, lens focus, white balance, lens iris, lens zoom and other functions of the camera from a local input device, a remote device or as automatic or programmed functions.

56-59. (Cancelled).

60. (Previously presented) The combination of Claim 55, further comprising a removable memory module [able to be] removably housed in the housing for storing captured image data signals.

61. (Cancelled).

62. (Previously presented) The combination of Claim 55, wherein the display is suitable also for viewing [incoming] image data signals received by the receiver.

63. (new) A combination of handheld wireless telephone and digital camera comprising:

a handheld housing which supports both the wireless telephone and the digital camera, the wireless telephone and electronic camera being commonly movable with the housing;

a display supported in the housing for framing an image to be captured and for viewing the image, whereby an operator can view and frame the image prior to capture;

a processor for processing the image framed by the camera for generating a digitized framed image as displayed in the display;

a memory associated with the processor for receiving and storing the digitized framed image, for selectively displaying in the display window and for selectively transmitting over a wireless telephone network the digitized framed image;

the wireless telephone being selectively operable to accept and digitize audio signals to be transmitted, the wireless telephone being selectively operable to convert received digitized audio signals into acoustic audio, the wireless telephone being selectively operable to transmit and receive non-audio digital signals, the non-audio digital signals including a selected digitized framed image;

a set of input keys supported by the housing to permit alphanumeric signals to be manually input by an operator into the wireless telephone, the alphanumeric signals

being presented in the display for viewing by the operator;

a power supply supported by the housing;

the wireless telephone including a wireless transmitter/receiver for transmitting digital signals sent from and receiving digital signals sent to the wireless telephone; and

at least one camera control circuit connected to an input device for controlling at least one of the following functions: gain, pedestal, setup, white clip, lens focus, white balance, lens iris, lens zoom.

64. (new) The combination of claim 63 and further comprising:

a removable memory module removably housed in the housing for storing captured images.

65. (new) The combination of claim 63 and further comprising:

the display also being operable for viewing images received by the receiver.

66. (new) The combination of claim 63 and further comprising:

the housing having a first portion, the housing having a second portion joined to the first portion, at least one of the first portion and the second portion being moveable in relation to the other of the first portion and the second portion, the first portion and the second portion also being commonly movable by hand when fixed in relation to each other.

### **Remarks**

Claims 42-45, 48, 50-52, 54-55, 60, and 62-66 are pending. Applicant acknowledges the Examiner's indication that claims 55, 60 and 62 contain allowable subject matter. Claims 55, 60 and 62 have been further amended to further clarify the patentable subject matter set forth therein. Claims 42-45, 48, 50-52 and 54 have also been amended. Claims 63-66 are new. Applicant respectfully requests entry of this Amendment. Applicant also requests consideration of the Supplemental Information Disclosure Statement submitted herewith. Applicant also respectfully requests issuance of a Notice of Allowance for claims 42-45, 48, 50-52, 54-55, 60 and 62-65 in view of these Remarks.

New claims 63-66 are entered in order to specify patentable subject of the disclosure. Applicant respectfully submits that no additional fee is required for consideration of the new claims.

The Examiner rejected claims 43-45, 48, 50-52 and 54 under 35 USC §103(a) as being unpatentable over Kawazu JP 06-268582 (Kawazu) in view of Ida US 5,191,601 (Ida). The Examiner asserts that Kawazu teaches each claimed element, but acknowledges that Kawazu does not teach a display which displays an image framed by the camera. The Examiner asserts that Ida teaches, among other elements, a system (i) carried in a common case, (ii) a housing (videophone body 20) which defines the common case, (iii) an image capture device comprising an electronic camera (21) contained in the housing, and (iv) a display for displaying an image framed by the camera (image display 12). The Examiner also explains or asserts that Kawazu and Ida can be combined because both are in same field of endeavor, because both are telephones having a camera for transmitting images over a phone network.

Applicant respectfully traverses the rejections of claims 43-45, 48, 50-52 and 54 under 35 USC §103(a). First, Applicant disagrees with the Examiner's initial statement under "Response to Arguments" (page 2 of Office Action mailed March 8, 2007) which reads:

*"Applicant argues that Ida does not teach that the selected picture is transmitted to remote station."*

This statement is not correct. The Examiner has mischaracterized the Applicant's argument.

The Applicant simply does not make the argument characterized by the Examiner.

The Applicant asserts that Ida does not teach that the display displays an image framed by the camera and stored in the memory. As claimed, the present invention provides the ability for the user to selectively transmit and display images from memory. Applicant submits that the Examiner misapprehends Ida. Referring to Fig. 4 and Fig. 5 of Ida, it is clearly shown that Ida teaches transmitting a stored image from memory section 24, but Ida is shown in the same Fig. 4 and Fig. 5 to clearly lack the ability to display stored images on the device display of the apparatus which collects the image. This is because of the problem addressed by Ida – flickering images which otherwise would be transmitted to the remote receiver when the operator removes the camera 2 from hook 8. Ida solves this problem by transmitting a picture from memory section 24 to the remote receiver through switch 25. Switch 25 is not configured to direct a picture from memory section 24 to local display 12. This is clearly shown in both Figs. 4 and 5, and is consistent with the written description of Ida. There is no connection from the memory section 24 to the local display 12.

For this reason, Kawazu and Ida cannot be combined to reject the above referenced claims, which specify that images can be transmitted and displayed from memory. Careful



reconsideration of the Ida reference is again requested in view of these Remarks. The Examiner is requested to please look carefully at Ida's "memory section 24," Figs. 4 and 5 and accompanying text. A "photograph" stored in memory section 24 can only be transmitted to a remote station; it cannot be displayed on the user display 12. Ida teaches "selecting the memorized picture in the internal memory section 24 when the first detecting signal is provided from the hook 23" of the video camera. (Col. 5, lines 37-39 and surrounding text.) Ida discloses a video conferencing system wherein a "prescribed picture" stored in memory 24 is transmitted only when the local video camera goes "off hook" or when the user presses operating switch 22 on the video camera (Fig. 4). In either case, there is no teaching that the "prescribed picture" stored in memory is selectively displayed by the local user so that he can determine whether to transmit it to the remote station. In fact, Ida does not even disclose any electrical connection which would permit the photograph stored in the memory section 24 to be displayed on the display 12. The stated purpose of transmitting the stored image when the camera goes "off hook" is to send the remote station a pleasing, nonflickering picture when the local user moves his camera, and in that event the local user sees only the non-stored local video or the video received from the remote station – never the image stored in memory section 24. See col. 5, line 67 – col. 6, line 30.

In view of the foregoing, it is submitted that the Ida reference, properly understood, does not disclose selectively displaying or transmitting a framed image that has been stored in memory, as required variously by elements (e) and (f) of claims 43 and 51, as previously presented and as amended. Therefore, the proposed combination of Kawazu and Ida cannot render the claims obvious even if such combination would be proper.

Additionally, and in the alternative, Applicant respectfully asserts that Kawazu cannot be combined with Ida to reject the claims as asserted by the Examiner, because Ida teaches

away from the combination. As acknowledged by the Examiner, Kawazu does not teach displaying an image on the local display. In Ida, all embodiments teach a camera (camera 2) that is movable from the main housing (videophone body 20). Ida is directed to avoiding transmission of flickering images when camera 2 is removed from the hook 8 on videophone body 20. The same is true for each embodiment of Ida. (In the second embodiment of Ida, camera 21 is movable from unit 20, and in the third embodiment of Ida, camera 32 is movable apart from body 31.) Accordingly, Ida teaches a movable camera which is connected by a cable to a main videophone body for movement relative to the main videophone body. Therefore, one of skill in the art would have no reason or motivation to turn to Ida, because all embodiments of Ida are related to camera which is movable relative to a main body, but the construction specified in the present claims is directed to a camera which is commonly movable with the housing. Thus, Ida cannot be combined with Kawazu to reject these claims. Alternatively, even if combined, Ida would teach a construction wherein the camera is moveable relative to the housing, and such a construction is not specified in the pending claims.

Applicant respectfully submits that, in addition to allowable claims 55, 60 and 62, claims 43-45, 48, 50-52, and 54, and new claims 63-66, are distinguishable from the cited references and are allowable for the reasons stated above. The requested amendment is believed to place the application in condition for allowance or in better condition for appeal, and its entry is therefore respectfully solicited. If the Examiner has any other matters which pertain to this Application, the Examiner is encouraged to contact the undersigned to resolve these matters by Examiner's Amendment where possible.

Applicant respectfully requests that the Examiner contact the undersigned by phone at (512) 499-8900, in the event that the Examiner desires to discuss any issue pertaining to this application. The Commissioner is hereby authorized to withdraw any underpayment of any fees, or to credit any overpayment, associated with this Application from, or to, Moore Landrey, LLP. Deposit Account No. 01-0477.

Respectfully submitted,

/Jeffrey D. Hunt/

---

Jeffrey D. Hunt, Reg. 38,189

Date: September 7, 2007

MOORE LANDREY, LLP  
1609 Shoal Creek Blvd., Ste. 100  
Austin, Texas 78701  
Telephone: (512) 499-8900  
Facsimile: (512) 320-8906



UNITED STATES PATENT AND TRADEMARK OFFICE

MA

UNITED STATES DEPARTMENT OF COMMERCE  
United States Patent and Trademark Office  
Address: COMMISSIONER FOR PATENTS  
P.O. Box 1450  
Alexandria, Virginia 22313-1450  
www.uspto.gov

| APPLICATION NO. | FILING DATE | FIRST NAMED INVENTOR | ATTORNEY DOCKET NO. | CONFIRMATION NO. |
|-----------------|-------------|----------------------|---------------------|------------------|
| 10/336,470      | 01/03/2003  | David A. Monroe      | 121817.002.042      | 8448             |

7590 03/08/2007  
 Kirt S. O'Neill  
 AKIN, GUMP, STRAUSS, HAUER & FELD, L.L.P.  
 P.O. Box 12870  
 San Antonio, TX 78212

EXAMINER

SAFAIPOUR, HOUSHANG

| ART UNIT | PAPER NUMBER |
|----------|--------------|
|          | 2625         |

2625

| SHORTENED STATUTORY PERIOD OF RESPONSE | MAIL DATE  | DELIVERY MODE |
|--|------------|---------------|
| 3 MONTHS                               | 03/08/2007 | PAPER         |

Please find below and/or attached an Office communication concerning this application or proceeding.

If NO period for reply is specified above, the maximum statutory period will apply and will expire 6 MONTHS from the mailing date of this communication.

**Office Action Summary**

|                                       |   |  |
|---------------------------------------|---|--|
| <b>Application No.</b><br>10/336,470  | <b>Applicant(s)</b><br>MONROE, DAVID A. |  |
| <b>Examiner</b><br>Houshang Safaipour | <b>Art Unit</b><br>2625                 |  |

-- The MAILING DATE of this communication appears on the cover sheet with the correspondence address --

**Period for Reply**

A SHORTENED STATUTORY PERIOD FOR REPLY IS SET TO EXPIRE 3 MONTH(S) OR THIRTY (30) DAYS, WHICHEVER IS LONGER, FROM THE MAILING DATE OF THIS COMMUNICATION.

- Extensions of time may be available under the provisions of 37 CFR 1.136(a). In no event, however, may a reply be timely filed after SIX (6) MONTHS from the mailing date of this communication.
- If NO period for reply is specified above, the maximum statutory period will apply and will expire SIX (6) MONTHS from the mailing date of this communication.
- Failure to reply within the set or extended period for reply will, by statute, cause the application to become ABANDONED (35 U.S.C. § 133). Any reply received by the Office later than three months after the mailing date of this communication, even if timely filed, may reduce any earned patent term adjustment. See 37 CFR 1.704(b).

**Status**

- 1)  Responsive to communication(s) filed on 29 November 2006.
- 2a)  This action is **FINAL**.
- 2b)  This action is non-final.
- 3)  Since this application is in condition for allowance except for formal matters, prosecution as to the merits is closed in accordance with the practice under *Ex parte Quayle*, 1935 C.D. 11, 453 O.G. 213.

**Disposition of Claims**

- 4)  Claim(s) 43-45, 48, 50-52, 54, 55, 60 and 62 is/are pending in the application.  
4a) Of the above claim(s) \_\_\_\_\_ is/are withdrawn from consideration.
- 5)  Claim(s) 55, 60 and 62 is/are allowed.
- 6)  Claim(s) 43-45, 48, 50-52 and 54 is/are rejected.
- 7)  Claim(s) \_\_\_\_\_ is/are objected to.
- 8)  Claim(s) \_\_\_\_\_ are subject to restriction and/or election requirement.

**Application Papers**

- 9)  The specification is objected to by the Examiner.
- 10)  The drawing(s) filed on \_\_\_\_\_ is/are: a)  accepted or b)  objected to by the Examiner.  
Applicant may not request that any objection to the drawing(s) be held in abeyance. See 37 CFR 1.85(a).  
Replacement drawing sheet(s) including the correction is required if the drawing(s) is objected to. See 37 CFR 1.121(d).
- 11)  The oath or declaration is objected to by the Examiner. Note the attached Office Action or form PTO-152.

**Priority under 35 U.S.C. § 119**

- 12)  Acknowledgment is made of a claim for foreign priority under 35 U.S.C. § 119(a)-(d) or (f).  
a)  All b)  Some \* c)  None of:  
1.  Certified copies of the priority documents have been received.  
2.  Certified copies of the priority documents have been received in Application No. \_\_\_\_\_.  
3.  Copies of the certified copies of the priority documents have been received in this National Stage application from the International Bureau (PCT Rule 17.2(a)).

\* See the attached detailed Office action for a list of the certified copies not received.

**Attachment(s)**

- 1)  Notice of References Cited (PTO-892)
- 2)  Notice of Draftsperson's Patent Drawing Review (PTO-948)
- 3)  Information Disclosure Statement(s) (PTO/SB/08)  
Paper No(s)/Mail Date \_\_\_\_\_
- 4)  Interview Summary (PTO-413)  
Paper No(s)/Mail Date. \_\_\_\_\_
- 5)  Notice of Informal Patent Application
- 6)  Other: \_\_\_\_\_

## DETAILED ACTION

### *Continued Examination Under 37 CFR 1.114*

1. A request for continued examination under 37 CFR 1.114, including the fee set forth in 37 CFR 1.17(e), was filed in this application after final rejection. Since this application is eligible for continued examination under 37 CFR 1.114, and the fee set forth in 37 CFR 1.17(e) has been timely paid, the finality of the previous Office action has been withdrawn pursuant to 37 CFR 1.114. Applicant's submission filed on 10/02/2006 has been entered.

### *Response to Arguments*

Applicant argues that Ida does not teach that the selected picture is transmitted to remote station. Examiner respectfully disagrees. Ida's invention is directed towards "the video phone for transmitting still or moving pictures between one party [transmitting party] and another party [receiving party]" (col. 3, lines 41-43). Ida further discloses that in the conventional art "one party can not select the photographed area arbitrarily while viewing the photographed picture" (col. 4, lines 64-66). Ida overcomes this deficiency and teaches "one party can select the photographed area while viewing the photographed picture" (col. 5, lines 4-7). Ida discloses that by his invention "both parties are able to talk with each other while viewing each received picture" (col. 4, lines 49-56). Col. 4, lines 43-56 describes how the picture received at receiving terminal 5 (storage) is displayed at display unit 12 at one end and transmitted to the display unit 12 at the other end (figs. 2 and 3) in order for both parties to view the same picture. For the reason stated the examiner maintains his rejection of the claims over the prior arts.

***Claim Rejections - 35 USC § 103***

2. The following is a quotation of 35 U.S.C. 103(a) which forms the basis for all obviousness rejections set forth in this Office action:

(a) A patent may not be obtained though the invention is not identically disclosed or described as set forth in section 102 of this title, if the differences between the subject matter sought to be patented and the prior art are such that the subject matter as a whole would have been obvious at the time the invention was made to a person having ordinary skill in the art to which said subject matter pertains. Patentability shall not be negated by the manner in which the invention was made.

3. Claims 43-45, 48, 50-52, and 54 are rejected under 35 U.S.C. 103(a) as being unpatentable over Kawazu et al. (Japanese Patent Application JP 06-268582, with an English Abstract, and an English machine translation) in view of Ida et al. (U.S. Patent Number 5,191,601, cited in the Office action dated 12/16/05).

Regarding claim 43, Kawazu discloses a handheld self-contained cellular telephone and integrated image processing system both of which are carried in a common case (see Figs. 2, 5, and 7-12) for both sending and receiving telephonic audio signals and for capturing a visual image and transmitting it to a compatible remote receiving station (see abstract, and paragraphs 0008-0020 of the Detailed Description), the system comprising a housing defining the common case (see Figs. 2, 5, and 7-12), an integral image capture device comprising an electronic camera contained within the housing (lens 5, paragraphs 0039-0045 in the Detailed Description), a display (displays 4, paragraph 0011 in the Example), a processor in the housing for generating an image data signal representing the image framed by the camera (paragraphs 0011-0021), a memory associated with the processor for collecting and storing the image data signal (memory card 17, paragraph 0016-0025 in the Detailed Description), the processor for recalling the image data signal for viewing and transmission (paragraph 0016-0034 in the Detailed Description), a telephonic system in the housing for sending and receiving digitized audio signals and for

Art Unit: 2625

sending the image data signal (paragraphs 0015-0016 in the Detailed Description), alphanumeric input keys in the housing for permitting manually input digitized alphanumeric signals to be input to the processor (key group 3, paragraphs 0011, and 0042-0045 in the Detailed Description), the telephonic system further used for sending the digitized alphanumeric signals (paragraphs 0008-0020 of the Detailed Description), a wireless communications device for transmitting any of the digitized signals to a compatible remote receiving station (paragraphs 0008-0020 of the Detailed Description), and a power supply in the housing for powering the system (cell 9, paragraphs 0041-0048 in the Example).

However Kawazu fails to expressly disclose if the display displays an image framed by the camera.

Ida discloses a self-contained telephone and integrated image processing system both of which are carried in a common case (see Fig. 2) for both sending and receiving telephonic audio signals and for capturing a visual image and transmitting it to a compatible remote receiving station (column 3, line 41-column 4, line 19), the system comprising a housing defining a common case (video phone body 20, column 5, lines 14-66), an image capture device comprising an electronic camera contained (camera 21, being attached to the video phone unit, as seen in Fig. 2, a display for displaying an image framed by the camera (image display 12, column 4, lines 5-56), a processor (changeover switch 25) in the housing for generating an image data signal representing the image framed by the camera (column 5, line 36-column 6, line 18), a memory associated with the processor for collecting and storing the image data signal (memory section 24, column 5, line 36-column 6, line 30), the processor for recalling the image data signal for viewing and transmission (column 4, lines 5-56, and column 5, lines 50-column 6, line 30), a



Art Unit: 2625

telephonic system in the housing for sending and receiving digitized audio signals and for sending the image data signal (column 3, line 41-column 4, line 10), and alphanumeric input keys in the housing for permitting manually input digitized alphanumeric signals to be input to the processor (operating keyboard 13, column 5, lines 44-56).

Kawazu & Ida are combinable because they are from the same field of endeavor, being telephones having cameras for transmitting images over a telephone network. At the time of the invention, it would have been obvious to a person of ordinary skill in the art to include a display for displaying an image framed by the camera, as taught by Ida, in the system of Kawazu. The suggestion/motivation for doing so would have been that Kawazu's system would become more user-friendly with the addition of Ida's teachings, as a user would be able to view images that were taken by the camera, as recognized by Ida in column 1, lines 9-column 2, line 39. Therefore, it would have been obvious to combine the teachings of Ida with the system of Kawazu to obtain the invention as specified in claim 43.

Regarding claim 44, Kawazu and Ida disclose the system discussed above in claim 43, and Ida further teaches that the display for framing the image to be captured by the image capture device displays the image at the system whereby the image can be viewed and framed prior to capture in the memory (column 4, lines 5-56).

As discussed above, Kawazu & Ida are combinable because they are from the same field of endeavor, being telephones having cameras for transmitting images over a telephone network. At the time of the invention, it would have been obvious to a person of ordinary skill in the art to include a display for displaying an image framed by the camera, as taught by Ida, in the system of Kawazu. The suggestion/motivation for doing so would have been that Kawazu's system

Art Unit: 2625

would become more user-friendly with the addition of Ida's teachings, as a user would be able to view images that were taken by the camera, as recognized by Ida in column 1, lines 9-column 2, line 39. Therefore, it would have been obvious to combine the teachings of Ida with the system of Kawazu to obtain the invention as specified in claim 44.

Regarding claim 45, Kawazu and Ida disclose the system discussed above in claim 43, and Ida further teaches that the display is used for viewing alphanumeric messages input at the alphanumeric keys (column 8, lines 1-25).

As discussed above, Kawazu & Ida are combinable because they are from the same field of endeavor, being telephones having cameras for transmitting images over a telephone network. At the time of the invention, it would have been obvious to a person of ordinary skill in the art to include a display for displaying an image framed by the camera, as taught by Ida, in the system of Kawazu. The suggestion/motivation for doing so would have been that Kawazu's system would become more user-friendly with the addition of Ida's teachings, as a user would be able to view images that were taken by the camera, as recognized by Ida in column 1, lines 9-column 2, line 39. Therefore, it would have been obvious to combine the teachings of Ida with the system of Kawazu to obtain the invention as specified in claim 45.

Regarding claim 48, Kawazu and Ida disclose the system discussed above in claim 43, and Kawazu further teaches of a removable memory module in addition to the memory, the removable memory adapted to be removably housed in the housing for storing captured image data signals (memory card 17, paragraph 0016-0025 in the Detailed Description).

Regarding claim 50, Kawazu and Ida disclose the system discussed above in claim 43,

Art Unit: 2625

and Ida further teaches that the display is adapted for viewing incoming image data signals (column 4, lines 5-56).

As discussed above, Kawazu & Ida are combinable because they are from the same field of endeavor, being telephones having cameras for transmitting images over a telephone network. At the time of the invention, it would have been obvious to a person of ordinary skill in the art to include a display for displaying an image framed by the camera, as taught by Ida, in the system of Kawazu. The suggestion/motivation for doing so would have been that Kawazu's system would become more user-friendly with the addition of Ida's teachings, as a user would be able to view images that were taken by the camera, as recognized by Ida in column 1, lines 9-column 2, line 39. Therefore, it would have been obvious to combine the teachings of Ida with the system of Kawazu to obtain the invention as specified in claim 50.

Regarding claim 51, Kawazu discloses a handheld cellular telephone having an integrated electronic camera in a common case for both sending and receiving telephonic audio signals and for capturing a visual image (paragraphs 0008-0020 of the Detailed Description), converting the visual image to a digitized image data signal and transmitting digitized image data signal via a cellular telephone network (paragraphs 0008-0045 of the Detailed Description), the cellular telephone comprising a housing defining the common case (see Figs. 2, 5, and 7-12), a cellular telephone in the housing, the cellular telephone further including a transmitter/receiver for transmitting and receiving audio telephone messages over a cellular telephone network (paragraphs 0008-0020 of the Detailed Description), a keypad for entering manually input alphanumeric signals to be transmitted over the cellular telephone network (key group 3,

Art Unit: 2625

paragraphs 0011, and 0042-0045 in the Detailed Description), and a display window for viewing the manually input alphanumeric signals (displays 4, paragraph 0011 in the Example), an integral electronic camera in the housing ((lens 5, paragraphs 0039-0045 in the Detailed Description), the camera for visually framing a visual image to be captured (paragraphs 0039-0045 in the Detailed Description), a processor associated with the electronic camera for capturing and digitizing the framed image in a format for transmission over the cellular telephone network via the cellular telephone (paragraphs 0008-0020 of the Detailed Description), a memory associated with the processor for receiving and storing the digitized framed image (memory card 17, paragraph 0016-0025 in the Detailed Description) and transmitting it over a cellular telephone network (paragraphs 0008-0020 of the Detailed Description), and an integrated power supply for powering both the cellular telephone and the camera (cell 9, paragraphs 0041-0048 in the Example).

However, Kawazu fails to expressly disclose if the framed image is selectively displayed in the display window. Ida discloses a telephone having an integrated electronic camera in a common case for both sending and receiving telephonic audio signals and for capturing a visual image (see Fig. 2), converting the visual image to a digitized image data signal and transmitting digitized image data signal via a telephone network (column 3, line 41-column 4, line 19), the telephone comprising a housing defining the common case (video phone body 20, column 5, lines 14-66), a keypad for entering manually input alphanumeric signals to be transmitted over the cellular telephone network (operating keyboard 13, column 5, lines 44-56), and a display window for viewing the manually input alphanumeric signals (image display 12, column 4, lines 5-56), an electronic camera in the housing, the camera for visually framing a visual image to be

Art Unit: 2625

captured (camera 21, being attached to the video phone unit, as seen in Fig. 2), a processor associated with the electronic camera for capturing and digitizing the framed image in a format for transmission over the cellular telephone network via the cellular telephone (column 5, line 36-column 6, line 18), and a memory associated with the processor for receiving and storing the digitized framed image for selectively displaying it in the display window and transmitting it over the telephone network (column 4, lines 5-56, and column 5, lines 50-column 6, line 30).

Kawazu & Ida are combinable because they are from the same field of endeavor, being telephones having cameras for transmitting images over a telephone network. At the time of the invention, it would have been obvious to a person of ordinary skill in the art to include a display for displaying an image framed by the camera, as taught by Ida, in the system of Kawazu. The suggestion/motivation for doing so would have been that Kawazu's system would become more user-friendly with the addition of Ida's teachings, as a user would be able to view images that were taken by the camera, as recognized by Ida in column 1, lines 9-column 2, line 39.

Therefore, it would have been obvious to combine the teachings of Ida with the system of Kawazu to obtain the invention as specified in claim 51.

Regarding claim 52, Kawazu and Ida disclose the telephone discussed above in claim 51, and Ida further teaches of a display window for viewing the alphanumeric signals within the display window for framing the visual image (column 4, lines 5-56).

As discussed above, Kawazu & Ida are combinable because they are from the same field of endeavor, being telephones having cameras for transmitting images over a telephone network. At the time of the invention, it would have been obvious to a person of ordinary skill in the art to include a display for displaying an image framed by the camera, as taught by Ida, in the

Art Unit: 2625

system of Kawazu. The suggestion/motivation for doing so would have been that Kawazu's system would become more user-friendly with the addition of Ida's teachings, as a user would be able to view images that were taken by the camera, as recognized by Ida in column 1, lines 9-column 2, line 39. Therefore, it would have been obvious to combine the teachings of Ida with the system of Kawazu to obtain the invention as specified in claim 52.

Regarding claim 54, Kawazu and Ida disclose the telephone discussed above in claim 51, and Kawazu further teaches that of a second memory selectively removable from the housing (memory card 17, paragraph 0016-0025 in the Detailed Description).

***Allowable Subject Matter***

4. Claims 55, 60, and 62 are allowed.
5. The following is a statement of reasons for the indication of allowable subject matter:

Regarding claim 55, in the examiner's opinion, it would not have been obvious to have the system, as claimed, include the features of having a camera operation control capability through the use of digital/analog circuits for converting digital commands to analog signals for controlling gain, pedestal setup, white clip, lens focus, white balance, lens iris, lens zoom and other functions of the camera from a local input device, a remote device, or as automatic or programmed functions.

***Citation of Pertinent Prior Art***

6. The prior art made of record and not relied upon is considered pertinent to applicant's disclosure:

Art Unit: 2625

Katz (U.S. Patent Number 5,412,708) discloses a videophone system.

***Contact Information***

Any inquiry concerning this communication or earlier communications from the examiner should be directed to Houshang Safaipoor whose telephone number is (571)272-7412.

The examiner can normally be reached on Mon.-Fri. from 6:00am to 2:30pm.

If attempts to reach the examiner by telephone are unsuccessful, the examiner's supervisor, David Moore can be reached on (571)272-7437. The fax phone number for the organization where this application or proceeding is assigned is 571-273-8300.

Information regarding the status of an application may be obtained from the Patent Application Information Retrieval (PAIR) system. Status information for published applications may be obtained from either Private PAIR or Public PAIR. Status information for unpublished applications is available through Private PAIR only. For more information about the PAIR system, see <http://pair-direct.uspto.gov>. Should you have questions on access to the Private PAIR system, contact the Electronic Business Center (EBC) at 866-217-9197 (toll-free). If you would like assistance from a USPTO Customer Service Representative or access to the automated information system, call 800-786-9199 (IN USA OR CANADA) or 571-272-1000.

  
Houshang Safaipoor  
Patent Examiner  
March 3, 2007

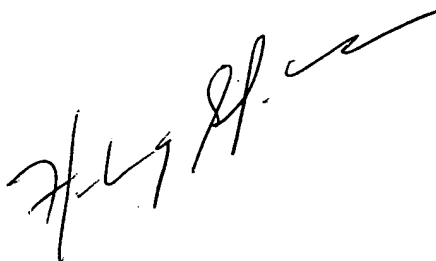

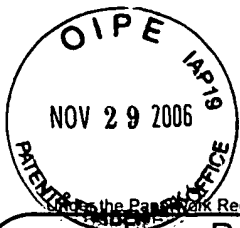

**Request  
 for  
 Continued Examination (RCE)  
 Transmittal**

Address to:  
 Mail Stop RCE  
 Commissioner for Patents  
 P.O. Box 1450  
 Alexandria, VA 22313-1450

|                        |                    |
|------------------------|--------------------|
| Application Number     | 10/336,470         |
| Filing Date            | January 3, 2003    |
| First Named Inventor   | David A. Monroe    |
| Art Unit               | 2625               |
| Examiner Name          | Joseph R. Pokrzywa |
| Attorney Docket Number | 121817.002.042     |

**This is a Request for Continued Examination (RCE) under 37 CFR 1.114 of the above-identified application.**  
 Request for Continued Examination (RCE) practice under 37 CFR 1.114 does not apply to any utility or plant application filed prior to June 8, 1995, or to any design application. See Instruction Sheet for RCEs (not to be submitted to the USPTO) on page 2.

1. **Submission required under 37 CFR 1.114** Note: If the RCE is proper, any previously filed unentered amendments and amendments enclosed with the RCE will be entered in the order in which they were filed unless applicant instructs otherwise. If applicant does not wish to have any previously filed unentered amendment(s) entered, applicant must request non-entry of such amendment(s).

- a.  Previously submitted. If a final Office action is outstanding, any amendments filed after the final Office action may be considered as a submission even if this box is not checked.
  - i.  Consider the arguments in the Appeal Brief or Reply Brief previously filed on \_\_\_\_\_
  - ii.  Other \_\_\_\_\_
- b.  Enclosed
  - i.  Amendment/Reply
  - ii.  Affidavit(s)/ Declaration(s)
  - iii.  Information Disclosure Statement (IDS)
  - iv.  Other \_\_\_\_\_

2. **Miscellaneous**

- a.  Suspension of action on the above-identified application is requested under 37 CFR 1.103(c) for a period of \_\_\_\_\_ months. (Period of suspension shall not exceed 3 months; Fee under 37 CFR 1.17(i) required)
- b.  Other \_\_\_\_\_

3. **Fees**

- The RCE fee under 37 CFR 1.17(e) is required by 37 CFR 1.114 when the RCE is filed.  
 The Director is hereby authorized to charge the following fees, any underpayment of fees, or credit any overpayments, to Deposit Account No. 01-0477. I have enclosed a duplicate copy of this sheet.
- a. 
    - i.  RCE fee required under 37 CFR 1.17(e) 11/29/2006 YPGLITE1 00000014 010477 10.36470
    - ii.  Extension of time fee (37 CFR 1.136 and 1.17) 01 FC:1001 150.00 DA  
02 FC:1251 120.00 DA
    - iii.  Other Information Disclosure Statement
  - b.  Check in the amount of \$ \_\_\_\_\_ enclosed
  - c.  Payment by credit card (Form PTO-2038 enclosed)

**WARNING: Information on this form may become public. Credit card information should not be included on this form. Provide credit card information and authorization on PTO-2038.**

**SIGNATURE OF APPLICANT, ATTORNEY, OR AGENT REQUIRED**

|                   |                        |                  |                      |
|-------------------|------------------------|------------------|----------------------|
| Signature         | <i>Kirt S. O'Neill</i> | Date             | <i>Nov. 27, 2006</i> |
| Name (Print/Type) | Kirt S. O'Neill        | Registration No. | 38,257               |

**CERTIFICATE OF MAILING OR TRANSMISSION**

I hereby certify that this correspondence is being deposited with the United States Postal Service with sufficient postage as first class mail in an envelope addressed to: Mail Stop RCE, Commissioner for Patents, P. O. Box 1450, Alexandria, VA 22313-1450 or facsimile transmitted to the U.S. Patent and Trademark Office on the date shown below.

|                   |                        |      |                      |
|-------------------|------------------------|------|----------------------|
| Signature         | <i>Kirt S. O'Neill</i> | Date | <i>Nov. 27, 2006</i> |
| Name (Print/Type) | Kirt S. O'Neill        |      |                      |

This collection of information is required by 37 CFR 1.114. The information is required to obtain or retain a benefit by the public which is to file (and by the USPTO to process) an application. Confidentiality is governed by 35 U.S.C. 122 and 37 CFR 1.11 and 1.14. This collection is estimated to take 12 minutes to complete, including gathering, preparing, and submitting the completed application form to the USPTO. Time will vary depending upon the individual case. Any comments on the amount of time you require to complete this form and/or suggestions for reducing this burden, should be sent to the Chief Information Officer, U.S. Patent and Trademark Office, U.S. Department of Commerce, P.O. Box 1450, Alexandria, VA 22313-1450. **DO NOT SEND FEES OR COMPLETED FORMS TO THIS ADDRESS. SEND TO: Mail Stop RCE, Commissioner for Patents, P.O. Box 1450, Alexandria, VA 22313-1450.**

If you need assistance in completing the form, call 1-800-PTO-9199 and select option 2.



*Handwritten initials*



UNITED STATES PATENT AND TRADEMARK OFFICE

UNITED STATES DEPARTMENT OF COMMERCE  
United States Patent and Trademark Office  
Address: COMMISSIONER FOR PATENTS  
P.O. Box 1450  
Alexandria, Virginia 22313-1450  
www.uspto.gov

| APPLICATION NO. | FILING DATE | FIRST NAMED INVENTOR | ATTORNEY DOCKET NO. | CONFIRMATION NO. |
|-----------------|-------------|----------------------|---------------------|------------------|
| 10/336,470      | 01/03/2003  | David A. Monroe      | 121817.002.042      | 8448             |

7590                      11/15/2006  
**Kirt S. O'Neill**  
**AKIN, GUMP, STRAUSS, HAUER & FELD, L.L.P.**  
**P.O. Box 12870**  
**San Antonio, TX 78212**

EXAMINER

SAFAIPOUR, HOUSHANG

|          |              |
|----------|--------------|
| ART UNIT | PAPER NUMBER |
|----------|--------------|

2625

DATE MAILED: 11/15/2006

Please find below and/or attached an Office communication concerning this application or proceeding.

**Advisory Action  
Before the Filing of an Appeal Brief**

|                                       |   |  |
|---------------------------------------|---|--|
| <b>Application No.</b><br>10/336,470  | <b>Applicant(s)</b><br>MONROE, DAVID A. |  |
| <b>Examiner</b><br>Houshang Safaipoor | <b>Art Unit</b><br>2625                 |  |

--The MAILING DATE of this communication appears on the cover sheet with the correspondence address --

THE REPLY FILED 02 October 2006 FAILS TO PLACE THIS APPLICATION IN CONDITION FOR ALLOWANCE.

1.  The reply was filed after a final rejection, but prior to or on the same day as filing a Notice of Appeal. To avoid abandonment of this application, applicant must timely file one of the following replies: (1) an amendment, affidavit, or other evidence, which places the application in condition for allowance; (2) a Notice of Appeal (with appeal fee) in compliance with 37 CFR 41.31; or (3) a Request for Continued Examination (RCE) in compliance with 37 CFR 1.114. The reply must be filed within one of the following time periods:

- a)  The period for reply expires 3 months from the mailing date of the final rejection.
- b)  The period for reply expires on: (1) the mailing date of this Advisory Action, or (2) the date set forth in the final rejection, whichever is later. In no event, however, will the statutory period for reply expire later than SIX MONTHS from the mailing date of the final rejection.
- Examiner Note: If box 1 is checked, check either box (a) or (b). ONLY CHECK BOX (b) WHEN THE FIRST REPLY WAS FILED WITHIN TWO MONTHS OF THE FINAL REJECTION. See MPEP 706.07(f).

Extensions of time may be obtained under 37 CFR 1.136(a). The date on which the petition under 37 CFR 1.136(a) and the appropriate extension fee have been filed is the date for purposes of determining the period of extension and the corresponding amount of the fee. The appropriate extension fee under 37 CFR 1.17(a) is calculated from: (1) the expiration date of the shortened statutory period for reply originally set in the final Office action; or (2) as set forth in (b) above, if checked. Any reply received by the Office later than three months after the mailing date of the final rejection, even if timely filed, may reduce any earned patent term adjustment. See 37 CFR 1.704(b).

**NOTICE OF APPEAL**

2.  The Notice of Appeal was filed on \_\_\_\_\_. A brief in compliance with 37 CFR 41.37 must be filed within two months of the date of filing the Notice of Appeal (37 CFR 41.37(a)), or any extension thereof (37 CFR 41.37(e)), to avoid dismissal of the appeal. Since a Notice of Appeal has been filed, any reply must be filed within the time period set forth in 37 CFR 41.37(a).

**AMENDMENTS**

3.  The proposed amendment(s) filed after a final rejection, but prior to the date of filing a brief, will not be entered because
- (a)  They raise new issues that would require further consideration and/or search (see NOTE below);
- (b)  They raise the issue of new matter (see NOTE below);
- (c)  They are not deemed to place the application in better form for appeal by materially reducing or simplifying the issues for appeal; and/or
- (d)  They present additional claims without canceling a corresponding number of finally rejected claims.

NOTE: See Continuation Sheet. (See 37 CFR 1.116 and 41.33(a)).

4.  The amendments are not in compliance with 37 CFR 1.121. See attached Notice of Non-Compliant Amendment (PTOL-324).
5.  Applicant's reply has overcome the following rejection(s): \_\_\_\_\_.
6.  Newly proposed or amended claim(s) \_\_\_\_\_ would be allowable if submitted in a separate, timely filed amendment canceling the non-allowable claim(s).
7.  For purposes of appeal, the proposed amendment(s): a)  will not be entered, or b)  will be entered and an explanation of how the new or amended claims would be rejected is provided below or appended.
- The status of the claim(s) is (or will be) as follows:
- Claim(s) allowed: \_\_\_\_\_.
- Claim(s) objected to: \_\_\_\_\_.
- Claim(s) rejected: \_\_\_\_\_.
- Claim(s) withdrawn from consideration: \_\_\_\_\_.

**AFFIDAVIT OR OTHER EVIDENCE**

8.  The affidavit or other evidence filed after a final action, but before or on the date of filing a Notice of Appeal will not be entered because applicant failed to provide a showing of good and sufficient reasons why the affidavit or other evidence is necessary and was not earlier presented. See 37 CFR 1.116(e).
9.  The affidavit or other evidence filed after the date of filing a Notice of Appeal, but prior to the date of filing a brief, will not be entered because the affidavit or other evidence failed to overcome all rejections under appeal and/or appellant fails to provide a showing a good and sufficient reasons why it is necessary and was not earlier presented. See 37 CFR 41.33(d)(1).
10.  The affidavit or other evidence is entered. An explanation of the status of the claims after entry is below or attached.

**REQUEST FOR RECONSIDERATION/OTHER**

11.  The request for reconsideration has been considered but does NOT place the application in condition for allowance because: \_\_\_\_\_.
12.  Note the attached Information Disclosure Statement(s). (PTO/SB/08) Paper No(s). \_\_\_\_\_
13.  Other: \_\_\_\_\_.

Continuation of 3. NOTE: The amended claims 43 and 51 recite a "user interface for enabling a user to select the image". Therefore the amendment has raised a new issue that requires further search and consideration .

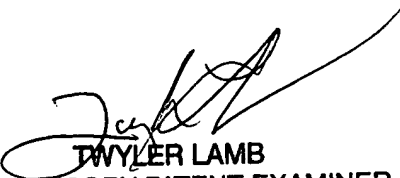

**TWYLER LAMB**  
SUPERVISORY PATENT EXAMINER

AKIN GUMP  
STRAUSS HAUER & FELD LLP

Attorneys at Law



KIRT S. O'NEILL  
210.281.7106/fax: 210.224.2035  
koneill@akingump.com

September 27, 2006

Commissioner for Patents  
P.O. Box 1450  
Alexandria, VA 22313-1450

Re: U.S. Patent Application No. 10/336,470  
Title: Apparatus for Capturing, Converting and Transmitting a Visual Image  
Signal Via a Digital Transmission System  
Applicant: David A. Monroe  
Our Reference: 683553.0058  
Docket No.: 121817.002.042

Dear Madam:

Enclosed please find the following for filing in the above-identified application:

- Response to Final Office Action Dated July 27, 2006; and
- A return receipt acknowledgment postcard.

The Commissioner is hereby authorized to charge any deficiency or credit any overpayment in the fees indicated above to Deposit Account No. 01-0477.

Sincerely,

A handwritten signature in cursive that reads "Kirt S. O'Neill".

Kirt S. O'Neill

Enclosures



## Amendments to the Claims

### Amendments to the Claims:

This listing of claims will replace all prior versions, and listings, of claims in the application:

### Listing of Claims:

1-42. (Cancelled)

43. (Currently amended) A handheld self-contained cellular telephone and integrated image processing system both of which are carried in a common case for both sending and receiving telephonic audio signals and for capturing a visual image and transmitting it to a compatible remote receiving station, the system comprising:

- a. A housing defining the common case;
- b. An integral image capture device comprising an electronic camera contained within the housing;
- c. A display for displaying an image framed by the camera;
- d. A processor in the housing for generating an image data signal representing the image framed by the camera;
- e. A memory associated with the processor for collecting and storing the image data signal;
- f. [The processor for recalling] A user interface for enabling a user to select the image data signal for viewing and transmission;
- g. A telephonic system in the housing for sending and receiving digitized audio signals and for sending the image data signal;
- h. Alphanumeric input keys in the housing for permitting manually input digitized alphanumeric signals to be input to the processor, the telephonic system further used for sending the digitized alphanumeric signals;
- i. A wireless communications device adapted for transmitting any of the digitized signals to the compatible remote receiving station; and
- j. A power supply in the housing for powering the system.

44. (Previously presented) The self-contained image processing system of Claim 43, wherein the display for framing the image to be captured by the image capture device displays the image at the system whereby the image can be viewed and framed prior to capture in the memory.

45. (Previously presented) The self-contained image processing system of Claim 43, wherein the display is used for viewing alphanumeric messages input at the alphanumeric keys.

46. (Cancelled)

47. (Cancelled)

48. (Previously presented) The self-contained image processing system of Claim 43, further comprising a removable memory module in addition to the memory, said removable memory able to be removably housed in the housing for storing captured image data signals.

49. (Cancelled)

50. (Previously presented) The self-contained image processing system of Claim 43, wherein the display is used for viewing incoming image data signals.

51. (Currently amended) A handheld cellular telephone having an integrated electronic camera in a common case for both sending and receiving telephonic audio signals and for capturing a visual image, converting the visual image to a digitized image data signal and transmitting digitized image data signal via a cellular telephone network, the cellular telephone comprising:

- a. A housing defining the common case;
- b. A cellular telephone in the housing, the cellular telephone further including a transmitter/receiver for transmitting and receiving audio telephone messages over a cellular telephone network, a keypad for entering manually input alphanumeric signals to be transmitted over the cellular telephone network, and a display window for viewing the manually input alphanumeric signals;
- c. An integral electronic camera in the housing, the camera for visually framing a visual image to be captured;
- d. A processor associated with the electronic camera for capturing and digitizing the framed image in a format for transmission over the cellular telephone network via the cellular telephone;
- e. A memory associated with the processor for receiving and storing the digitized framed image;
- f. A user interface for enabling a user to [for] selectively [displaying it] display the digitized framed image in the display window and [transmitting] subsequently transmit it over the cellular telephone network; and
- [f]g. An integrated power supply for powering both the cellular telephone and the camera.

52. (Previously presented) The cellular telephone of Claim 51, wherein the display window for viewing the alphanumeric signals is within the display window for framing the visual image.

53. (Cancelled)

54. (Previously presented) The cellular telephone of Claim 51, further including a second memory selectively removable from the housing.

55. (Previously presented) A combination of handheld cellular telephone and electronic camera in a unitary case comprising:

- a. A housing defining the case;
- b. A electronic camera integral within the housing;
- c. A display in the housing for framing the image to be captured by an image capture device and for viewing the image whereby an operator can view and frame the image prior to capture;
- d. A processor for processing the image framed by the camera for generating a digitized framed image as displayed in the display;
- e. A memory associated with the processor for receiving and storing the digitized framed image for selectively displaying it in the display window and transmitting it

- over a cellular telephone network;
- f. A cellular telephone in the housing for accepting and digitizing audio signals to be transmitted and for converting received digitized audio signals into acoustic audio, the cellular telephone further for transmitting and receiving non-audio digital signals including digitized image signals;
  - g. Alphanumeric input keys in the housing for permitting manually input alphanumeric signals to be input into the cellular telephone, the manually input alphanumeric signals being presented in the display;
  - h. A power supply in the housing for powering the processor, the cellular telephone, the display and the camera;
  - i. A wireless transmitter/receiver in the housing for transmitting digital signals sent from and receiving digital signals sent to the cellular telephone; and
  - j. camera operation control capability through the use of digital/analog circuits for converting digital commands to analog signals for controlling gain, pedestal, setup, white clip, lens focus, white balance, lens iris, lens zoom and other functions of the camera from a local input device, a remote device or as automatic or programmed functions.

56-59. (Cancelled)

60. (Previously presented) The combination of Claim 55, further comprising a removable memory module able to be removably housed in the housing for storing captured image data signals.

61. (Cancelled)

62. (Previously presented) The combination of Claim 55, wherein the display is for viewing incoming image data signals.



## Remarks and Arguments

Claims 43-45, 48, 50-52, 54, 55, 60, and 62 are pending. Claims 1-42, 46, 47, 49, 53, 56-59, and 61 have been cancelled. Claims 43 and 51 are currently amended. Claims 44 - 45, 48, 50, 55, 60, and 62 were previously presented. Claims 55, 60, and 62 were indicated to be allowable in the prior Office Action.

Applicant requests a minor amendment to independent claims 43 and 51 to clarify that the ability to selectively display and/or transmit a stored image is under the control of the user (operator), which is believed to have been at least implicit in the claims in view of Applicant's disclosure. It is believed that this clarification will assist the Examiner in reassessing the cited Ida reference, which appears to have been misapplied in the prior Office Action. Consequently, it is believed that such amendment places the claims in better condition for allowance or appeal.

The Examiner rejected claims independent claims 43 and 51, and their dependent claims 44, 45, 48, 50-52, and 54 under 35 USC § 103(a) as being unpatentable over Kawazu, et al (Japanese Patent Application JP 06-268582) in view of Ida, et al (U.S. Patent 5,191,601). The Examiner acknowledged that Kawazu does not disclose that the display displays an image framed by the camera and stored in the memory. As claimed, the present invention provides the ability for the user to selectively display and transmit images from memory. It is submitted that the Examiner misapprehends Ida, which completely lacks the ability to display stored images on the device display. Reconsideration of the Ida reference is requested. (Applicant need not address the Examiner's contention that Kawazu are properly combinable, since Ida does not in fact disclose the features contended by the Examiner.)

The Examiner is requested to please look carefully at Ida's "memory section 24," Figs. 4 and 5 and accompanying text. A "photograph" stored in memory section 24 can only be transmitted to a remote station; it cannot be displayed on the user display 12. Ida teaches "selecting the memorized picture in the internal memory section 24 when the first detecting signal is provided from the hook 23" of the video camera. Col. 5, lines 37-39 and surrounding text. Ida discloses a video conferencing system wherein a "prescribed picture" stored in memory 24 is transmitted only when the local video camera goes "off hook" or when the user presses operating switch 22 on the video camera (Fig. 4). In either case, there is no teaching that the "prescribed picture" stored in memory is selectively displayed by the local user so that he can determine whether to transmit it to the remote station. In fact, Ida does not even disclose any electrical connection which would permit the photograph stored in the memory section 24 to be displayed on the display 12. The stated purpose of transmitting the stored image when the camera goes "off hook" is to send the remote station a pleasing, nonflickering picture when the local user moves his camera, and in that event the local user sees only the non-stored local video or the video received from the remote station – never the image stored in memory section 24. See col. 5, line 67 – col. 6, line 30.

In view of the foregoing, it is submitted that the Ida reference, properly understood, does not disclose selectively displaying or transmitting a framed image that has been stored in memory, as required variously by elements (e) and (f) of claims 43 and 51, as previously presented and as amended. Therefore, the proposed combination of Kawazu and Ida cannot render the claims obvious even if such combination would be proper.

Applicant respectfully submits that claims 43-45, 48, 50-52, and 54 are distinguishable from the cited references and are now allowable for the reasons stated above. The requested amendment is believed to place the application in condition for allowance or in better condition for appeal, and its entry is therefor respectfully solicited. If the Examiner has any other matters which pertain to this Application, the Examiner is encouraged to contact the undersigned to resolve these matters by Examiner's Amendment where possible.

The Commissioner is hereby authorized to withdraw or credit any filing fees associated with this Response from Deposit Account No. 01-0477.

Respectfully submitted,



\_\_\_\_\_  
Kirt S. O'Neill, Reg. 38,257

Date: September 27, 2006

AKIN GUMP STRAUSS HAUER & FELD, LLP  
P.O. Box 12870  
San Antonio, Texas 78212  
Telephone: (210) 281-7106  
Facsimile: (210) 224-2035

#### CERTIFICATE OF MAILING

I hereby certify that this correspondence is being deposited with the United States Postal Service with sufficient postage as first class mail in an envelope addressed to Commissioner for Patents, P.O. Box 1450, Alexandria, VA 22313-1450 on September 27, 2006.

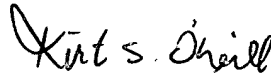

\_\_\_\_\_  
Kirt S. O'Neill, Reg. No. 38,257



UNITED STATES PATENT AND TRADEMARK OFFICE

UNITED STATES DEPARTMENT OF COMMERCE  
United States Patent and Trademark Office  
Address: COMMISSIONER FOR PATENTS  
P.O. Box 1450  
Alexandria, Virginia 22313-1450  
www.uspto.gov

| APPLICATION NO. | FILING DATE | FIRST NAMED INVENTOR | ATTORNEY DOCKET NO. | CONFIRMATION NO. |
|-----------------|-------------|----------------------|---------------------|------------------|
| 10/336,470      | 01/03/2003  | David A. Monroe      | 121817.002.042      | 8448             |

7590 07/27/2006

Robert Curfiss  
P.O. Box 3171  
Houston, TX 77253-3171

EXAMINER

POKRZYWA, JOSEPH R

ART UNIT PAPER NUMBER

2625

DATE MAILED: 07/27/2006

Please find below and/or attached an Office communication concerning this application or proceeding.



## DETAILED ACTION

### *Response to Amendment*

1. Applicant's amendment was received on 5/16/06, and has been entered and made of record. Currently, **claims 43-45, 48, 50-52, 54, 55, 60, and 62** are pending.

### *Claim Rejections - 35 USC § 103*

2. The following is a quotation of 35 U.S.C. 103(a) which forms the basis for all obviousness rejections set forth in this Office action:

(a) A patent may not be obtained though the invention is not identically disclosed or described as set forth in section 102 of this title, if the differences between the subject matter sought to be patented and the prior art are such that the subject matter as a whole would have been obvious at the time the invention was made to a person having ordinary skill in the art to which said subject matter pertains. Patentability shall not be negated by the manner in which the invention was made.

3. **Claims 43-45, 48, 50-52, and 54** are rejected under 35 U.S.C. 103(a) as being unpatentable over Kawazu *et al.* (Japanese Patent Application JP 06-268582, with an English Abstract, and an English machine translation) in view of Ida *et al.* (U.S. Patent Number 5,191,601, cited in the Office action dated 12/16/05).

Regarding **claim 43**, Kawazu discloses a handheld self-contained cellular telephone and integrated image processing system both of which are carried in a common case (see Figs. 2, 5, and 7-12) for both sending and receiving telephonic audio signals and for capturing a visual image and transmitting it to a compatible remote receiving station (see abstract, and paragraphs 0008-0020 of the Detailed Description), the system comprising a housing defining the common case (see Figs. 2, 5, and 7-12), an integral image capture device comprising an electronic camera contained within the housing (lens 5, paragraphs 0039-0045 in the Detailed Description), a

Art Unit: 2625

display (displays 4, paragraph 0011 in the Example), a processor in the housing for generating an image data signal representing the image framed by the camera (paragraphs 0011-0021), a memory associated with the processor for collecting and storing the image data signal (memory card 17, paragraph 0016-0025 in the Detailed Description), the processor for recalling the image data signal for viewing and transmission (paragraph 0016-0034 in the Detailed Description), a telephonic system in the housing for sending and receiving digitized audio signals and for sending the image data signal (paragraphs 0015-0016 in the Detailed Description), alphanumeric input keys in the housing for permitting manually input digitized alphanumeric signals to be input to the processor (key group 3, paragraphs 0011, and 0042-0045 in the Detailed Description), the telephonic system further used for sending the digitized alphanumeric signals (paragraphs 0008-0020 of the Detailed Description), a wireless communications device for transmitting any of the digitized signals to a compatible remote receiving station (paragraphs 0008-0020 of the Detailed Description), and a power supply in the housing for powering the system (cell 9, paragraphs 0041-0048 in the Example).

However Kawazu fails to expressly disclose if the display displays an image framed by the camera.

Ida discloses a self-contained telephone and integrated image processing system both of which are carried in a common case (see Fig. 2) for both sending and receiving telephonic audio signals and for capturing a visual image and transmitting it to a compatible remote receiving station (column 3, line 41-column 4, line 19), the system comprising a housing defining a common case (video phone body 20, column 5, lines 14-66), an image capture device comprising an electronic camera contained (camera 21, being attached to the video phone unit, as seen in Fig.

Art Unit: 2625

2), a display for displaying an image framed by the camera (image display 12, column 4, lines 5-56), a processor (changeover switch 25) in the housing for generating an image data signal representing the image framed by the camera (column 5, line 36-column 6, line 18), a memory associated with the processor for collecting and storing the image data signal (memory section 24, column 5, line 36-column 6, line 30), the processor for recalling the image data signal for viewing and transmission (column 4, lines 5-56, and column 5, lines 50-column 6, line 30), a telephonic system in the housing for sending and receiving digitized audio signals and for sending the image data signal (column 3, line 41-column 4, line 10), and alphanumeric input keys in the housing for permitting manually input digitized alphanumeric signals to be input to the processor (operating keyboard 13, column 5, lines 44-56).

Kawazu & Ida are combinable because they are from the same field of endeavor, being telephones having cameras for transmitting images over a telephone network. At the time of the invention, it would have been obvious to a person of ordinary skill in the art to include a display for displaying an image framed by the camera, as taught by Ida, in the system of Kawazu. The suggestion/motivation for doing so would have been that Kawazu's system would become more user-friendly with the addition of Ida's teachings, as a user would be able to view images that were taken by the camera, as recognized by Ida in column 1, lines 9-column 2, line 39. Therefore, it would have been obvious to combine the teachings of Ida with the system of Kawazu to obtain the invention as specified in claim 43.

Regarding *claim 44*, Kawazu and Ida disclose the system discussed above in claim 43, and Ida further teaches that the display for framing the image to be captured by the image

Art Unit: 2625

capture device displays the image at the system whereby the image can be viewed and framed prior to capture in the memory (column 4, lines 5-56).

As discussed above, Kawazu & Ida are combinable because they are from the same field of endeavor, being telephones having cameras for transmitting images over a telephone network. At the time of the invention, it would have been obvious to a person of ordinary skill in the art to include a display for displaying an image framed by the camera, as taught by Ida, in the system of Kawazu. The suggestion/motivation for doing so would have been that Kawazu's system would become more user-friendly with the addition of Ida's teachings, as a user would be able to view images that were taken by the camera, as recognized by Ida in column 1, lines 9-column 2, line 39. Therefore, it would have been obvious to combine the teachings of Ida with the system of Kawazu to obtain the invention as specified in claim 44.

Regarding *claim 45*, Kawazu and Ida disclose the system discussed above in claim 43, and Ida further teaches that the display is used for viewing alphanumeric messages input at the alphanumeric keys (column 8, lines 1-25).

As discussed above, Kawazu & Ida are combinable because they are from the same field of endeavor, being telephones having cameras for transmitting images over a telephone network. At the time of the invention, it would have been obvious to a person of ordinary skill in the art to include a display for displaying an image framed by the camera, as taught by Ida, in the system of Kawazu. The suggestion/motivation for doing so would have been that Kawazu's system would become more user-friendly with the addition of Ida's teachings, as a user would be able to view images that were taken by the camera, as recognized by Ida in column 1, lines 9-column 2,



line 39. Therefore, it would have been obvious to combine the teachings of Ida with the system of Kawazu to obtain the invention as specified in claim 45.

Regarding *claim 48*, Kawazu and Ida disclose the system discussed above in claim 43, and Kawazu further teaches of a removable memory module in addition to the memory, the removable memory adapted to be removably housed in the housing for storing captured image data signals (memory card 17, paragraph 0016-0025 in the Detailed Description).

Regarding *claim 50*, Kawazu and Ida disclose the system discussed above in claim 43, and Ida further teaches that the display is adapted for viewing incoming image data signals (column 4, lines 5-56).

As discussed above, Kawazu & Ida are combinable because they are from the same field of endeavor, being telephones having cameras for transmitting images over a telephone network. At the time of the invention, it would have been obvious to a person of ordinary skill in the art to include a display for displaying an image framed by the camera, as taught by Ida, in the system of Kawazu. The suggestion/motivation for doing so would have been that Kawazu's system would become more user-friendly with the addition of Ida's teachings, as a user would be able to view images that were taken by the camera, as recognized by Ida in column 1, lines 9-column 2, line 39. Therefore, it would have been obvious to combine the teachings of Ida with the system of Kawazu to obtain the invention as specified in claim 50.

Regarding *claim 51*, Kawazu discloses a handheld cellular telephone having an integrated electronic camera in a common case for both sending and receiving telephonic audio signals and for capturing a visual image (paragraphs 0008-0020 of the Detailed Description), converting the visual image to a digitized image data signal and transmitting digitized image data signal via a

Art Unit: 2625

cellular telephone network (paragraphs 0008-0045 of the Detailed Description), the cellular telephone comprising a housing defining the common case (see Figs. 2, 5, and 7-12), a cellular telephone in the housing, the cellular telephone further including a transmitter/receiver for transmitting and receiving audio telephone messages over a cellular telephone network (paragraphs 0008-0020 of the Detailed Description), a keypad for entering manually input alphanumeric signals to be transmitted over the cellular telephone network (key group 3, paragraphs 0011, and 0042-0045 in the Detailed Description), and a display window for viewing the manually input alphanumeric signals (displays 4, paragraph 0011 in the Example), an integral electronic camera in the housing ((lens 5, paragraphs 0039-0045 in the Detailed Description), the camera for visually framing a visual image to be captured (paragraphs 0039-0045 in the Detailed Description), a processor associated with the electronic camera for capturing and digitizing the framed image in a format for transmission over the cellular telephone network via the cellular telephone (paragraphs 0008-0020 of the Detailed Description), a memory associated with the processor for receiving and storing the digitized framed image (memory card 17, paragraph 0016-0025 in the Detailed Description) and transmitting it over a cellular telephone network (paragraphs 0008-0020 of the Detailed Description), and an integrated power supply for powering both the cellular telephone and the camera (cell 9, paragraphs 0041-0048 in the Example).

However, Kawazu fails to expressly disclose if the framed image is selectively displayed in the display window.

Ida discloses a telephone having an integrated electronic camera in a common case for both sending and receiving telephonic audio signals and for capturing a visual image (see Fig. 2),

Art Unit: 2625

converting the visual image to a digitized image data signal and transmitting digitized image data signal via a telephone network (column 3, line 41-column 4, line 19), the telephone comprising a housing defining the common case (video phone body 20, column 5, lines 14-66), a keypad for entering manually input alphanumeric signals to be transmitted over the cellular telephone network (operating keyboard 13, column 5, lines 44-56), and a display window for viewing the manually input alphanumeric signals (image display 12, column 4, lines 5-56), an electronic camera in the housing, the camera for visually framing a visual image to be captured (camera 21, being attached to the video phone unit, as seen in Fig. 2), a processor associated with the electronic camera for capturing and digitizing the framed image in a format for transmission over the cellular telephone network via the cellular telephone (column 5, line 36-column 6, line 18), and a memory associated with the processor for receiving and storing the digitized framed image for selectively displaying it in the display window and transmitting it over the telephone network (column 4, lines 5-56, and column 5, lines 50-column 6, line 30).

Kawazu & Ida are combinable because they are from the same field of endeavor, being telephones having cameras for transmitting images over a telephone network. At the time of the invention, it would have been obvious to a person of ordinary skill in the art to include a display for displaying an image framed by the camera, as taught by Ida, in the system of Kawazu. The suggestion/motivation for doing so would have been that Kawazu's system would become more user-friendly with the addition of Ida's teachings, as a user would be able to view images that were taken by the camera, as recognized by Ida in column 1, lines 9-column 2, line 39. Therefore, it would have been obvious to combine the teachings of Ida with the system of Kawazu to obtain the invention as specified in claim 51.

Regarding *claim 52*, Kawazu and Ida disclose the telephone discussed above in claim 51, and Ida further teaches of a display window for viewing the alphanumeric signals within the display window for framing the visual image (column 4, lines 5-56).

As discussed above, Kawazu & Ida are combinable because they are from the same field of endeavor, being telephones having cameras for transmitting images over a telephone network. At the time of the invention, it would have been obvious to a person of ordinary skill in the art to include a display for displaying an image framed by the camera, as taught by Ida, in the system of Kawazu. The suggestion/motivation for doing so would have been that Kawazu's system would become more user-friendly with the addition of Ida's teachings, as a user would be able to view images that were taken by the camera, as recognized by Ida in column 1, lines 9-column 2, line 39. Therefore, it would have been obvious to combine the teachings of Ida with the system of Kawazu to obtain the invention as specified in claim 52.

Regarding *claim 54*, Kawazu and Ida disclose the telephone discussed above in claim 51, and Kawazu further teaches that of a second memory selectively removable from the housing (memory card 17, paragraph 0016-0025 in the Detailed Description).

***Allowable Subject Matter***

4. **Claims 55, 60, and 62** are allowed.
5. The following is a statement of reasons for the indication of allowable subject matter:

Regarding *claim 55*, in the examiner's opinion, it would not have been obvious to have the system, as claimed, include the features of having a camera operation control capability through the use of digital /analog circuits for converting digital commands to analog signals for

controlling gain, pedestal setup, white clip, lens focus, white balance, lens iris, lens zoom and other functions of the camera from a local input device, a remote device, or as automatic or programmed functions.

*Citation of Pertinent Prior Art*

6. The prior art made of record and not relied upon is considered pertinent to applicant's disclosure:

**Katz** (U.S. Patent Number 5,412,708) discloses a videophone system.

*Conclusion*

7. Applicant's amendment necessitated the new ground(s) of rejection presented in this Office action. Accordingly, **THIS ACTION IS MADE FINAL**. See MPEP § 706.07(a). Applicant is reminded of the extension of time policy as set forth in 37 CFR 1.136(a).

A shortened statutory period for reply to this final action is set to expire **THREE MONTHS** from the mailing date of this action. In the event a first reply is filed within **TWO MONTHS** of the mailing date of this final action and the advisory action is not mailed until after the end of the **THREE-MONTH** shortened statutory period, then the shortened statutory period will expire on the date the advisory action is mailed, and any extension fee pursuant to 37 CFR 1.136(a) will be calculated from the mailing date of the advisory action. In no event, however, will the statutory period for reply expire later than **SIX MONTHS** from the date of this final action.

Art Unit: 2625

8. Any inquiry concerning this communication or earlier communications from the examiner should be directed to Joe Pokrzywa whose telephone number is (571) 272-7410. The examiner can normally be reached on Monday-Friday, 9:00-5:00.

If attempts to reach the examiner by telephone are unsuccessful, the examiner's supervisor, Edward L. Coles can be reached on (571) 272-7402. The fax phone number for the organization where this application or proceeding is assigned is 571-273-8300.

Information regarding the status of an application may be obtained from the Patent Application Information Retrieval (PAIR) system. Status information for published applications may be obtained from either Private PAIR or Public PAIR. Status information for unpublished applications is available through Private PAIR only. For more information about the PAIR system, see <http://pair-direct.uspto.gov>. Should you have questions on access to the Private PAIR system, contact the Electronic Business Center (EBC) at 866-217-9197 (toll-free). If you would like assistance from a USPTO Customer Service Representative or access to the automated information system, call 800-786-9199 (IN USA OR CANADA) or 571-272-1000.

Joseph R. Pokrzywa  
Primary Examiner  
Art Unit 2625

jrj



JOSEPH R. POKRZYWA  
PRIMARY EXAMINER

MAY 16 2006

IN THE UNITED STATES PATENT AND TRADEMARK OFFICE

|                               |   |                              |
|-------------------------------|---|------------------------------|
| In re Application of:         | § |                              |
|                               | § |                              |
| David A. Monroe               | § | Group Art Unit: 2622         |
|                               | § |                              |
| Serial No.: 10/336,470        | § | Examiner: Joseph R. Pokrzywa |
|                               | § |                              |
| Filed: January 3, 2003        | § | Docket No. 121817.0002.042   |
|                               | § |                              |
| For: APPARATUS FOR CAPTURING, | § |                              |
| CONVERTING AND                | § |                              |
| TRANSMITTING A VISUAL         | § |                              |
| IMAGE SIGNAL VIA A DIGITAL    | § |                              |
| TRANSMISSION SYSTEM           | § |                              |

Commissioner for Patents  
P.O. Box 1450  
Alexandria, Virginia 22313-1450

**RESPONSE TO OFFICE ACTION DATED 12/16/2005**

Sir:

This is a response to the Office Action mailed on 12/16/2005 and is timely filed.

Please amend the application as follows:

**Amendments to the Claims** are reflected in the listing of the claims which begin on page 2 of this paper.

**Remarks** begin on page 6 of this paper.

**Amendments to the Claims:**

This listing of claims will replace all prior versions, and listings, of claims in the application:

**Listing of Claims:**

1-42. (Cancelled)

43. (Currently Amended) A handheld self-contained cellular telephone and integrated image processing system both of which are carried in a common case for both sending and receiving telephonic audio signals and for capturing a visual image and transmitting it to a compatible remote receiving station, the system comprising:

- a. A housing defining the common case;
- b. An integral image capture device comprising an an electronic camera contained within the housing;
- c. A display for displaying an image framed by the camera;
- d. A processor in the housing for generating an image data signal representing the image framed by the camera;
- e. A memory associated with the processor for collecting and storing the image data signal;
- f. The processor [adapted] for recalling the image data signal for viewing and transmission;
- g. A telephonic system in the housing for sending and receiving digitized audio signals and [adapted] for sending the image data signal;
- h. Alphanumeric input keys in the housing for permitting manually input digitized alphanumeric signals to be input to the processor, the telephonic system [being] further [adapted] used for sending the digitized alphanumeric signals;
- i. A wireless communications device [adapted] for transmitting any of the digitized signals to the compatible remote receiving station; and
- j. A power supply in the housing for powering the system.



44. (Currently Amended) The self-contained image processing system of Claim 43, wherein the display for framing the image to be captured by the image capture device [is adapted for displaying] displays the image at the system whereby the image can be viewed and framed prior to capture in the memory.

45. (Currently Amended) The self-contained image processing system of Claim 43, wherein the display is [adapted] used for viewing alphanumeric messages input at the alphanumeric keys.

46. (Cancelled)

47. (Cancelled)

48. (Currently Amended) The self-contained image processing system of Claim 43, further comprising a removable memory module in addition to the memory, said removable memory [adapted] able to be removably housed in the housing for storing captured image data signals.

49. (Cancelled)

50. (Currently Amended) The self-contained image processing system of Claim 43, wherein the display is [adapted] used for viewing incoming image data signals.

51. (Currently Amended) A handheld cellular telephone having an integrated electronic camera in a common case for both sending and receiving telephonic audio signals and for capturing a visual image, converting the visual image to a digitized image data signal and transmitting digitized image data signal via a cellular telephone network, the cellular telephone comprising:

- a. A housing defining the common case;
- b. A cellular telephone in the housing, the cellular telephone further including a transmitter/receiver for transmitting and receiving audio telephone messages over a

- cellular telephone network, a keypad for entering manually input alphanumeric signals to be transmitted over the cellular telephone network, and a display window for viewing the manually input alphanumeric signals;
- c. An integral electronic camera in the housing, the [digitized] camera [adapted] for visually framing a visual image to be captured;
  - d. A processor associated with the electronic camera for capturing and digitizing the framed image in a format [adapted] for transmission over the cellular telephone network via the cellular telephone;
  - e. A memory associated with the processor for receiving and storing the digitized framed image for selectively displaying it in the display window and transmitting it over the cellular telephone network; and
  - f. An integrated power supply for powering both the cellular telephone and the camera.

52. (Previously presented) The cellular telephone of Claim 51, wherein the display window for viewing the alphanumeric signals is within the display window for framing the visual image.

53. (Cancelled)

54. (Previously presented) The cellular telephone of Claim 51, further including a second memory selectively removable from the housing.

55. (Currently Amended) A combination of handheld cellular telephone and electronic camera in a unitary case comprising:

- a. A housing defining the case;
- b. An electronic camera integral within the housing;
- c. A display in the housing for framing the image to be captured by an image capture device and for viewing the image whereby an operator can view and frame the image prior to capture;
- d. A processor for processing the image framed by the camera for generating a digitized framed image as displayed in the display;

- e. A memory associated with the processor for receiving and storing the digitized framed image for selectively displaying it in the display window and transmitting it over a cellular telephone network;
- f. A cellular telephone in the housing [and adapted] for accepting and digitizing audio signals to be transmitted and for converting received digitized audio signals into acoustic audio, the cellular telephone further [adapted] used for transmitting and receiving non-audio digital signals including digitized image signals;
- g. Alphanumeric input keys in the housing for permitting manually input alphanumeric signals to be input into the cellular telephone, the manually input alphanumeric signals being presented in the display;
- h. A power supply in the housing for powering the processor, the cellular telephone, the display and the camera; [and]
- i. A wireless transmitter/receiver in the housing for transmitting digital signals sent from and receiving digital signals sent to the cellular telephone[.]; and
- j. camera operation control capability through the use of digital/analog circuits for converting digital commands to analog signals for controlling gain, pedestal, setup, white clip, lens focus, white balance, lens iris, lens zoom and other functions of the camera from a local input device, a remote device or as automatic or programmed functions.

56-59. (Cancelled)

60. (Currently Amended) The combination of Claim 55, further comprising a removable memory module [adapted] able to be removably housed in the housing for storing captured image data signals.

61. (Cancelled)

62. (Currently Amended) The combination of Claim 55, wherein the display is [adapted] used for viewing incoming image data signals.

REMARKS

Claims 1-42, 46, 47, 49, 53, 56-59, and 61 are cancelled, claims 43, 45, 48, 50, 51, 55, 60, and 62 are currently amended, and claims 52 and 54 were previously presented.

Claim 43

Claim 43 was primarily amended as follows:

“An integral image capture device comprising an electronic camera contained within the housing;”

Support for such a limitation can be found at least in paragraph [0017] of the present patent application.

Claim 51

Claim 51 was primarily amended as follows:

“An integral electronic camera in the housing, the camera for visually framing a visual image to be captured;”

Support for such a limitation can be found at least in paragraph [0017] of the present patent application.

Claim 55

Claim 55 was primarily amended as follows:

“An electronic camera integral within the housing;” and  
“camera operation control capability through the use of digital/analog circuits for converting digital commands to analog signals for controlling gain, pedestal, setup, white clip, lens focus, white balance, lens iris, lens zoom and other functions of the camera from a local input device, a remote device or as automatic or programmed functions.”

Support for such a limitation can be found at least in paragraphs [0017] and [0087] of the present patent application.

Other amendments focused on grammatical changes and removing or replacing the word "adapted."

#### Cited Prior Art

The Examiner rejected the currently pending claims based on Collet (5,517,683) and Ida (5,191,601). The currently amended independent claims 43, 51, and 55 claim, among other elements, an integral electronic camera in the housing. According to Webster's II New College Dictionary, Third Edition, the definition of the term integral is as follows:

- "1. Essential for completeness
2. Having everything required: Entire"

Collet, in column 8, lines 12-19 and Figures 7a and 7b, describes and depicts a vertical arm section 32 that is modified by the addition of a modular micro-camera. The vertical arm section can also accommodate a modular speaker 22 as depicted in Figure 1, for example. As such, Collet describes a phone in which various devices (speakers, cameras, etc.) can be effectively clipped-on to provide certain functionality and are thus not integral to the phone. They are external devices that are temporarily positioned to accomplish a certain function.

As such, Applicant believes currently amended independent claims 43, 51, and 55, as well as the claims that depend from them, are in condition for allowance and respectfully request they be passed to allowance.

Respectfully submitted,



Raffi Gostanian, Jr.  
Registered Patent Agent for Applicant  
Reg. No. 42,595  
(972) 849-1310

Please send all correspondences to:

Robert C. Curfiss  
808 Travis Street, Ste. 1447  
Houston, Texas 77002  
(832) 573-1442

### 3. Design concepts

- a. Two interfaces in the container - The current concept of having two different interfaces in the container (one for loading the payload and one for loading the PCM cassette) will greatly increase the heat leak into the container. I suggest that the design be changed to only have the one interface necessary to load the payload in the container. This one interface will still have many times the heat leak that is in the current KT1000, and we must be careful with the design to reduce this heat leak (see below).
- b. Cassette concept
  - i. If the cassette could be loaded into the lid of the container and be secured when the lid was turned upside down, then we could still use the cassette concept and eliminate the extra joint in the vacuum container.
  - ii. I have been concerned about the cassette concept since the mating surfaces of the heat path in the PCM, H-plate, thermal switch, and convection plate assembly is very critical. I was concerned on how we could consistently interface the cassette with the fixed part of the heat path assembly and maintain the close contact necessary to have consistent performance.
  - iii. If we make the cassette encompass the convection plate, the vacuum panel, and the H-Plate assembly with the PCM, the heat path is never disturbed after it is manufactured and tested. This entire assembly can be frozen and then be inserted and secured into the top of the vacuum box.
- c. Interface between the bottom and lid of the container
  - i. As stated before, the thermal conductivity of the SS is approximately 39 times the LDPE. This will result in considerably more heat leak across the interface than with polymer.
  - ii. An idea to evaluate might be to lengthen the heat path from the outside to the inside by making the lid overlap the base rather than butt up against it. The longer the overlap (example - 2 inches), the lower the heat leak across the interface.
  - iii. We could use some of the available heat transfer programs to evaluate various designs to identify options to prototype.

RM



UNITED STATES PATENT AND TRADEMARK OFFICE

UNITED STATES DEPARTMENT OF COMMERCE  
United States Patent and Trademark Office  
Address: COMMISSIONER FOR PATENTS  
P.O. Box 1450  
Alexandria, Virginia 22313-1450  
www.uspto.gov

| APPLICATION NO. | FILING DATE | FIRST NAMED INVENTOR | ATTORNEY DOCKET NO. | CONFIRMATION NO. |
|-----------------|-------------|----------------------|---------------------|------------------|
| 10/336,470      | 01/03/2003  | David A. Monroe      | 121817.0002.042     | 8448             |

53445                      7590                      12/16/2005

ROBERT C. CURFISS  
P.O. BOX 903  
HUMBLE, TX 77347

EXAMINER

POKRZYWA, JOSEPH R

| ART UNIT | PAPER NUMBER |
|----------|--------------|
| 2622     |              |

2622

DATE MAILED: 12/16/2005

Please find below and/or attached an Office communication concerning this application or proceeding.





## DETAILED ACTION

### *Continued Examination Under 37 CFR 1.114*

1. A request for continued examination under 37 CFR 1.114, including the fee set forth in 37 CFR 1.17(e), was filed in this application after final rejection. Since this application is eligible for continued examination under 37 CFR 1.114, and the fee set forth in 37 CFR 1.17(e) has been timely paid, the finality of the previous Office action has been withdrawn pursuant to 37 CFR 1.114. Applicant's submission filed on 12/1/05 has been entered.

### *Response to Amendment*

2. Applicant's amendment was received on 9/29/05, and has been entered and made of record. Currently, **claims 43-45, 48, 50-52, 54, 55, 60, and 62** are pending.

### *Drawings*

3. The drawings received on 9/29/05 are acceptable by the examiner.

### *Claim Rejections - 35 USC § 103*

4. The following is a quotation of 35 U.S.C. 103(a) which forms the basis for all obviousness rejections set forth in this Office action:

(a) A patent may not be obtained though the invention is not identically disclosed or described as set forth in section 102 of this title, if the differences between the subject matter sought to be patented and the prior art are such that the subject matter as a whole would have been obvious at the time the invention was made to a person having ordinary skill in the art to which said subject matter pertains. Patentability shall not be negated by the manner in which the invention was made.

Art Unit: 2622

5. **Claims 43-45, 48, 50-52, 54, 55, 60, and 62** are rejected under 35 U.S.C. 103(a) as being unpatentable over Collett *et al.* (U.S. Patent Number 5,517,683, cited in the Office action dated 8/9/05) in view of Ida *et al.* (U.S. Patent Number 5,191,601).

Regarding **claim 43**, Collett discloses a handheld self-contained cellular telephone and integrated image processing system both of which are carried in a common case (see abstract and Figs. 1a, 1b, 7a, and 7b) for both sending and receiving telephonic audio signals and for capturing a visual image and transmitting it to a compatible remote receiving station (column 8, lines 1-25), the system comprising a housing defining the common case (see Figs. 1a, 1b, 7a, and 7b), an image capture device comprising a electronic camera contained within the housing (column 8, lines 1-25), a display for displaying an image framed by the camera (display panel 14 and LCD screen 124, column 3, lines 54-57, column 8, lines 21-25), a processor (printed circuit board 38, seen in Figs. 1b-4) in the housing for generating an image data signal representing the image framed by the camera (video display control electronics, column 8, lines 20-25), a telephonic system in the housing for sending and receiving digitized audio signals and adapted for sending the image data signal (column 3, lines 54-column 4, line 32, and column 8, lines 1-25), alphanumeric input keys in the housing for permitting manually input digitized alphanumeric signals to be input to the processor (column 3, lines 54-column 4, line 32), the telephonic system being further adapted for sending the digitized alphanumeric signals (column 8, lines 1-11), a wireless communications device adapted for transmitting any of the digitized signals to a compatible remote receiving station (column 8, line 26-column 9, line 55), and a power supply in the housing for powering the system (column 4, lines 7-18, and column 5, lines 13-25).

Art Unit: 2622

However, Collett fails to expressly disclose of a memory associated with the processor for collecting and storing the image data signal, and if the processor is adapted for recalling the image data signal for viewing and transmission.

Ida discloses a self-contained telephone and integrated image processing system both of which are carried in a common case (see Fig. 2) for both sending and receiving telephonic audio signals and for capturing a visual image and transmitting it to a compatible remote receiving station (column 3, line 41-column 4, line 19), the system comprising a housing defining a common case (video phone body 20, column 5, lines 14-66), an image capture device comprising a electronic camera contained (camera 21, being attached to the video phone unit, as seen in Fig. 2), a display for displaying an image framed by the camera (image display 12, column 4, lines 5-56), a processor (changeover switch 25) in the housing for generating an image data signal representing the image framed by the camera (column 5, line 36-column 6, line 18), a memory associated with the processor for collecting and storing the image data signal (memory section 24, column 5, line 36-column 6, line 30), the processor adapted for recalling the image data signal for viewing and transmission (column 4, lines 5-56, and column 5, lines 50-column 6, line 30), a telephonic system in the housing for sending and receiving digitized audio signals and adapted for sending the image data signal (column 3, line 41-column 4, line 10), and alphanumeric input keys in the housing for permitting manually input digitized alphanumeric signals to be input to the processor (operating keyboard 13, column 5, lines 44-56).

Collett & Ida are combinable because they are from the same field of endeavor, being picture/telephone systems that can transmit pictures via a telephone signal. At the time of the invention, it would have been obvious to a person of ordinary skill in the art to consider the

Art Unit: 2622

display and memory of Ida in the system of Collett. The suggestion/motivation for doing so would have been that Collett's system would become more user-friendly, allowing users to store image data and display the images for viewing on a display, as recognized by Ida in column 1, lines 9-column 2, line 39. Therefore, it would have been obvious to combine the teachings of Ida with the system of Collett to obtain the invention as specified in claim 43.

Regarding *claim 44*, Collett and Ida disclose the system discussed above in claim 43, and Ida further teaches that the display for framing the image to be captured by the image capture device is adapted for displaying the image at the system whereby the image can be viewed and framed prior to capture in the memory (column 4, lines 5-56).

As discussed above, Collett & Ida are combinable because they are from the same field of endeavor, being picture/telephone systems that can transmit pictures via a telephone signal. At the time of the invention, it would have been obvious to a person of ordinary skill in the art to consider the display and memory of Ida in the system of Collett. The suggestion/motivation for doing so would have been that Collett's system would become more user-friendly, allowing users to store image data and display the images for viewing on a display, as recognized by Ida in column 1, lines 9-column 2, line 39. Therefore, it would have been obvious to combine the teachings of Ida with the system of Collett to obtain the invention as specified in claim 44.

Regarding *claim 45*, Collett and Ida disclose the system discussed above in claim 43, and Ida further teaches that the display is adapted for viewing alphanumeric messages input at the alphanumeric keys (column 8, lines 1-25).

Regarding *claim 48*, Collett and Ida disclose the system discussed above in claim 43, and Collett further teaches of a removable memory module in addition to the memory, the removable

Art Unit: 2622

memory adapted to be removably housed in the housing for storing captured image data signals (see Fig. 6, column 7, lines 36-67).

Regarding *claim 50*, Collett and Ida disclose the system discussed above in claim 43, and Ida further teaches that the display is adapted for viewing incoming image data signals (column 4, lines 5-56).

As discussed above, Collett & Ida are combinable because they are from the same field of endeavor, being picture/telephone systems that can transmit pictures via a telephone signal. At the time of the invention, it would have been obvious to a person of ordinary skill in the art to consider the display and memory of Ida in the system of Collett. The suggestion/motivation for doing so would have been that Collett's system would become more user-friendly, allowing users to store image data and display the images for viewing on a display, as recognized by Ida in column 1, lines 9-column 2, line 39. Therefore, it would have been obvious to combine the teachings of Ida with the system of Collett to obtain the invention as specified in claim 50.

Regarding *claim 51*, Collett discloses a handheld cellular telephone having an integrated electronic camera in a common case for both sending and receiving telephonic audio signals and for capturing a visual image (see abstract, Figs. 1a, 1b, 7a, and 7b, and column 8, lines 1-25), converting the visual image to a digitized image data signal and transmitting digitized image data signal via a cellular telephone network, the cellular telephone comprising a housing defining the common case (see Figs. 1a, 1b, 7a, and 7b), a cellular telephone in the housing, the cellular telephone further including a transmitter/receiver for transmitting and receiving audio telephone messages over a cellular telephone network (column 3, lines 54-column 4, line 32, and column 8, lines 1-25), a keypad for entering manually input alphanumeric signals to be transmitted over the

Art Unit: 2622

cellular telephone network (column 3, lines 54-column 4, line 32), and a display window for viewing the manually input alphanumeric signals (LCD screen 124, column 8, lines 21-25), an electronic camera in the housing (column 8, lines 1-25), the digitized camera adapted for visually framing a visual image to be captured, a processor associated with the electronic camera for capturing and digitizing the framed image in a format adapted for transmission over the cellular telephone network via the cellular telephone (column 8, lines 1-25), and an integrated power supply for powering both the cellular telephone and the camera (column 4, lines 7-18, and column 5, lines 13-25).

However, Collett fails to expressly disclose of a memory associated with the processor for receiving and storing the digitized framed image for selectively displaying it in the display window and transmitting it over the cellular telephone network.

Ida discloses a telephone having an integrated electronic camera in a common case for both sending and receiving telephonic audio signals and for capturing a visual image (see Fig. 2), converting the visual image to a digitized image data signal and transmitting digitized image data signal via a telephone network (column 3, line 41-column 4, line 19), the telephone comprising a housing defining the common case (video phone body 20, column 5, lines 14-66), a keypad for entering manually input alphanumeric signals to be transmitted over the cellular telephone network (operating keyboard 13, column 5, lines 44-56), and a display window for viewing the manually input alphanumeric signals (image display 12, column 4, lines 5-56), an electronic camera in the housing, the digitized camera adapted for visually framing a visual image to be captured (camera 21, being attached to the video phone unit, as seen in Fig. 2), a processor associated with the electronic camera for capturing and digitizing the framed image in a format

Art Unit: 2622

adapted for transmission over the cellular telephone network via the cellular telephone (column 5, line 36-column 6, line 18), and a memory associated with the processor for receiving and storing the digitized framed image for selectively displaying it in the display window and transmitting it over the telephone network (column 4, lines 5-56, and column 5, lines 50-column 6, line 30).

Collett & Ida are combinable because they are from the same field of endeavor, being picture/telephone systems that can transmit pictures via a telephone signal. At the time of the invention, it would have been obvious to a person of ordinary skill in the art to consider the display and memory of Ida in the system of Collett. The suggestion/motivation for doing so would have been that Collett's system would become more user-friendly, allowing users to store image data and display the images for viewing on a display, as recognized by Ida in column 1, lines 9-column 2, line 39. Therefore, it would have been obvious to combine the teachings of Ida with the system of Collett to obtain the invention as specified in claim 51.

Regarding *claim 52*, Collett and Ida disclose the telephone discussed above in claim 51, and Ida further teaches of a display window for viewing the alphanumeric signals within the display window for framing the visual image (column 4, lines 5-56).

As discussed above, Collett & Ida are combinable because they are from the same field of endeavor, being picture/telephone systems that can transmit pictures via a telephone signal. At the time of the invention, it would have been obvious to a person of ordinary skill in the art to consider the display and memory of Ida in the system of Collett. The suggestion/motivation for doing so would have been that Collett's system would become more user-friendly, allowing users to store image data and display the images for viewing on a display, as recognized by Ida



Art Unit: 2622

in column 1, lines 9-column 2, line 39. Therefore, it would have been obvious to combine the teachings of Ida with the system of Collett to obtain the invention as specified in claim 52.

Regarding *claim 54*, Collett and Ida disclose the telephone discussed above in claim 51, and Collett further teaches that of a second memory selectively removable from the housing (see Fig. 6, column 7, lines 36-67).

Regarding *claim 55*, Collett discloses a combination of handheld cellular telephone and electronic camera in a unitary case (see Figs. 1a, 1b, 7a, and 7b, column 8, lines 1-25) comprising a housing defining the case (see Figs. 1a, 1b, 7a, and 7b), a electronic camera in the housing (column 8, lines 1-25), a display in the housing (LCD screen 124, column 8, lines 21-25), a processor for processing the image framed by the camera (printed circuit board 38, seen in Figs. 1b-4, via the video display control electronics, column 8, lines 20-25), a cellular telephone in the housing and adapted for accepting and digitizing audio signals to be transmitted and for converting received digitized audio signals into acoustic audio (column 3, lines 54-column 4, line 32), the cellular telephone further adapted for transmitting and receiving non-audio digital signals including digitized image signals (column 3, lines 54-column 4, line 32, and column 8, lines 1-25), alphanumeric input keys in the housing for permitting manually input alphanumeric signals to be input into the cellular telephone (column 3, lines 54-column 4, line 32), the manually input alphanumeric signals being presented in the display (column 8, lines 1-25), a power supply in the housing for powering the processor, the cellular telephone, the display and the camera (column 4, lines 7-18, and column 5, lines 13-25), a wireless transmitter/receiver in the housing for transmitting digital signals sent from and receiving digital signals sent to the cellular telephone (column 8, line 26-column 9, line 55).

Art Unit: 2622

However, Collett fails to expressly disclose of a display in the housing for framing the image to be captured by an image capture device and for viewing the image whereby an operator can view and frame the image prior to capture, a processor for processing the image framed by the camera for generating a digitized framed image as displayed in the display, and a memory associated with the processor for receiving and storing the digitized framed image for selectively displaying it in the display window and transmitting it over a cellular telephone network.

Ida discloses a combination of handheld telephone and electronic camera in a unitary case (see Fig. 2) comprising a housing defining the case (video phone body 20, column 5, lines 14-66), a electronic camera in the housing (camera 21, being attached to the video phone unit, as seen in Fig. 2), a display in the housing for framing the image to be captured by an image capture device and for viewing the image whereby an operator can view and frame the image prior to capture (image display 12, column 4, lines 5-56), a processor for processing the image framed by the camera for generating a digitized framed image as displayed in the display (column 5, line 36-column 6, line 18), a memory associated with the processor for receiving and storing the digitized framed image for selectively displaying it in the display window and transmitting it over a telephone network (column 4, lines 5-56, and column 5, lines 50-column 6, line 30), alphanumeric input keys in the housing for permitting manually input alphanumeric signals to be input into the cellular telephone (operating keyboard 13, column 5, lines 44-56), and the manually input alphanumeric signals being presented in the display (column 4, lines 5-56).

Collett & Ida are combinable because they are from the same field of endeavor, being picture/telephone systems that can transmit pictures via a telephone signal. At the time of the invention, it would have been obvious to a person of ordinary skill in the art to consider the

Art Unit: 2622

display and memory of Ida in the system of Collett. The suggestion/motivation for doing so would have been that Collett's system would become more user-friendly, allowing users to store image data and display the images for viewing on a display, as recognized by Ida in column 1, lines 9-column 2, line 39. Therefore, it would have been obvious to combine the teachings of Ida with the system of Collett to obtain the invention as specified in claim 55.

Regarding *claim 60*, Collett and Ida disclose the combination discussed above in claim 55, and Collett further teaches of a removable memory module adapted to be removably housed in the housing for storing captured image data signals (see Fig. 6, column 7, lines 36-67).

Regarding *claim 62*, Collett and Ida disclose the combination discussed above in claim 60, and Ida further teaches that the display is adapted for viewing incoming image data signals (column 4, lines 5-56).

As discussed above, Collett & Ida are combinable because they are from the same field of endeavor, being picture/telephone systems that can transmit pictures via a telephone signal. At the time of the invention, it would have been obvious to a person of ordinary skill in the art to consider the display and memory of Ida in the system of Collett. The suggestion/motivation for doing so would have been that Collett's system would become more user-friendly, allowing users to store image data and display the images for viewing on a display, as recognized by Ida in column 1, lines 9-column 2, line 39. Therefore, it would have been obvious to combine the teachings of Ida with the system of Collett to obtain the invention as specified in claim 62.

Art Unit: 2622

***Citation of Pertinent Prior Art***

6. The prior art made of record and not relied upon is considered pertinent to applicant's disclosure:

**Morris et al.** (U.S. Patent Number 4,884,132) discloses a personal security system having a camera and a cellular communication unit.

***Conclusion***

7. Any inquiry concerning this communication or earlier communications from the examiner should be directed to Joe Pokrzywa whose telephone number is (571) 272-7410. The examiner can normally be reached on Monday-Friday, 9:00-5:00.

If attempts to reach the examiner by telephone are unsuccessful, the examiner's supervisor, Edward L. Coles can be reached on (571) 272-7402. The fax phone number for the organization where this application or proceeding is assigned is 571-273-8300.

Information regarding the status of an application may be obtained from the Patent Application Information Retrieval (PAIR) system. Status information for published applications may be obtained from either Private PAIR or Public PAIR. Status information for unpublished applications is available through Private PAIR only. For more information about the PAIR system, see <http://pair-direct.uspto.gov>. Should you have questions on access to the Private PAIR system, contact the Electronic Business Center (EBC) at 866-217-9197 (toll-free).

Joseph R. Pokrzywa  
Primary Examiner  
Art Unit 2622



jrj

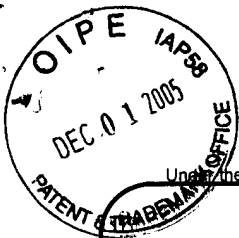

RCE  
2622  
C.L.  
IPW

PTO/SB/30 (04-05)

Approved for use through 07/31/2006. OMB 0651-0031  
U.S. Patent and Trademark Office; U.S. DEPARTMENT OF COMMERCE

Under the Paperwork Reduction Act of 1995, no persons are required to respond to a collection of information unless it contains a valid OMB control number.

### Request for Continued Examination (RCE) Transmittal

Address to:  
Mail Stop RCE  
Commissioner for Patents  
P.O. Box 1450  
Alexandria, VA 22313-1450

|                        |                    |
|------------------------|--------------------|
| Application Number     | 10/336,470         |
| Filing Date            | January 3, 2003    |
| First Named Inventor   | David A. Monroe    |
| Art Unit               | 2622               |
| Examiner Name          | Joseph R. Pokrzywa |
| Attorney Docket Number | 121817.002.042     |

**This is a Request for Continued Examination (RCE) under 37 CFR 1.114 of the above-identified application.**  
Request for Continued Examination (RCE) practice under 37 CFR 1.114 does not apply to any utility or plant application filed prior to June 8, 1995, or to any design application. See Instruction Sheet for RCEs (not to be submitted to the USPTO) on page 2.

1. **Submission required under 37 CFR 1.114** Note: If the RCE is proper, any previously filed unentered amendments and amendments enclosed with the RCE will be entered in the order in which they were filed unless applicant instructs otherwise. If applicant does not wish to have any previously filed unentered amendment(s) entered, applicant must request non-entry of such amendment(s).

- a.  Previously submitted. If a final Office action is outstanding, any amendments filed after the final Office action may be considered as a submission even if this box is not checked.
  - i.  Consider the arguments in the Appeal Brief or Reply Brief previously filed on \_\_\_\_\_
  - ii.  Other \_\_\_\_\_
- b.  Enclosed
  - i.  Amendment/Reply
  - ii.  Affidavit(s)/ Declaration(s)
  - iii.  Information Disclosure Statement (IDS)
  - iv.  Other Petition for Two-Month Extension of Time

### 2. Miscellaneous

- a.  Suspension of action on the above-identified application is requested under 37 CFR 1.103(c) for a period of \_\_\_\_\_ months. (Period of suspension shall not exceed 3 months; Fee under 37 CFR 1.17(i) required)
- b.  Other \_\_\_\_\_

### 3. Fees

- The RCE fee under 37 CFR 1.17(e) is required by 37 CFR 1.114 when the RCE is filed.
- The Director is hereby authorized to charge the following fees, any underpayment of fees, or credit any overpayments, to Deposit Account No. \_\_\_\_\_ I have enclosed a duplicate copy of this sheet.
- a. 
    - i.  RCE fee required under 37 CFR 1.17(e)
    - ii.  Extension of time fee (37 CFR 1.136 and 1.17)
    - iii.  Other \_\_\_\_\_
  - b.  Check in the amount of \$ \_\_\_\_\_ enclosed
  - c.  Payment by credit card (Form PTO-2038 enclosed)

**WARNING: Information on this form may become public. Credit card information should not be included on this form. Provide credit card information and authorization on PTO-2038.**

### SIGNATURE OF APPLICANT, ATTORNEY, OR AGENT REQUIRED

|                   |                   |                  |                   |
|-------------------|-------------------|------------------|-------------------|
| Signature         |                   | Date             | November 29, 2005 |
| Name (Print/Type) | Robert C. Curfiss | Registration No. | 26,540            |

### CERTIFICATE OF MAILING OR TRANSMISSION

I hereby certify that this correspondence is being deposited with the United States Postal Service with sufficient postage as first class mail in an envelope addressed to: Mail Stop RCE, Commissioner for Patents, P. O. Box 1450, Alexandria, VA 22313-1450 or facsimile transmitted to the U.S. Patent and Trademark Office on the date shown below.

|                   |                          |      |                   |
|-------------------|--------------------------|------|-------------------|
| Signature         | <i>Judith Ann Kruger</i> | Date | November 29, 2005 |
| Name (Print/Type) | Judith Ann Kruger        |      |                   |

This collection of information is required by 37 CFR 1.114. The information is required to obtain or retain a benefit by the public which is to file (and by the USPTO to process) an application. Confidentiality is governed by 35 U.S.C. 122 and 37 CFR 1.11 and 1.14. This collection is estimated to take 12 minutes to complete, including gathering, preparing, and submitting the completed application form to the USPTO. Time will vary depending upon the individual case. Any comments on the amount of time you require to complete this form and/or suggestions for reducing this burden, should be sent to the Chief Information Officer, U.S. Patent and Trademark Office, U.S. Department of Commerce, P.O. Box 1450, Alexandria, VA 22313-1450. **DO NOT SEND FEES OR COMPLETED FORMS TO THIS ADDRESS. SEND TO: Mail Stop RCE, Commissioner for Patents, P.O. Box 1450, Alexandria, VA 22313-1450.**

If you need assistance in completing the form, call 1-800-PTO-9199 and select option 2.

12/02/2005 DENHANI1 00000007 10336470  
790.00 DP  
01 FC:1801



UNITED STATES PATENT AND TRADEMARK OFFICE

UNITED STATES DEPARTMENT OF COMMERCE  
United States Patent and Trademark Office  
Address: COMMISSIONER FOR PATENTS  
P.O. Box 1450  
Alexandria, Virginia 22313-1450  
www.uspto.gov

| APPLICATION NO. | FILING DATE | FIRST NAMED INVENTOR | ATTORNEY DOCKET NO. | CONFIRMATION NO. |
|-----------------|-------------|----------------------|---------------------|------------------|
| 10/336,470      | 01/03/2003  | David A. Monroe      | 121817.0002.042     | 8448             |

7590 11/02/2005  
 Robert C Curfiss  
 JACKSON WALKER L.L.P.  
 112 E. Pecan Street, Suite 2100  
 San Antonio, TX 78205

EXAMINER

POKRZYWA, JOSEPH R

| ART UNIT | PAPER NUMBER |
|----------|--------------|
| 2622     |              |

2622

DATE MAILED: 11/02/2005

Please find below and/or attached an Office communication concerning this application or proceeding.

|   |                                       |   |  |
|---|---------------------------------------|---|--|
| <b>Advisory Action<br/>Before the Filing of an Appeal Brief</b> | <b>Application No.</b><br>10/336,470  | <b>Applicant(s)</b><br>MONROE, DAVID A. |  |
|   | <b>Examiner</b><br>Joseph R. Pokrzywa | <b>Art Unit</b><br>2622                 |  |

**--The MAILING DATE of this communication appears on the cover sheet with the correspondence address --**

THE REPLY FILED 29 September 2005 FAILS TO PLACE THIS APPLICATION IN CONDITION FOR ALLOWANCE.

1.  The reply was filed after a final rejection, but prior to or on the same day as filing a Notice of Appeal. To avoid abandonment of this application, applicant must timely file one of the following replies: (1) an amendment, affidavit, or other evidence, which places the application in condition for allowance; (2) a Notice of Appeal (with appeal fee) in compliance with 37 CFR 41.31; or (3) a Request for Continued Examination (RCE) in compliance with 37 CFR 1.114. The reply must be filed within one of the following time periods:

- a)  The period for reply expires \_\_\_\_\_ months from the mailing date of the final rejection.  
b)  The period for reply expires on: (1) the mailing date of this Advisory Action, or (2) the date set forth in the final rejection, whichever is later. In no event, however, will the statutory period for reply expire later than SIX MONTHS from the mailing date of the final rejection.

Examiner Note: If box 1 is checked, check either box (a) or (b). ONLY CHECK BOX (b) WHEN THE FIRST REPLY WAS FILED WITHIN TWO MONTHS OF THE FINAL REJECTION. See MPEP 706.07(f).

Extensions of time may be obtained under 37 CFR 1.136(a). The date on which the petition under 37 CFR 1.136(a) and the appropriate extension fee have been filed is the date for purposes of determining the period of extension and the corresponding amount of the fee. The appropriate extension fee under 37 CFR 1.17(a) is calculated from: (1) the expiration date of the shortened statutory period for reply originally set in the final Office action; or (2) as set forth in (b) above, if checked. Any reply received by the Office later than three months after the mailing date of the final rejection, even if timely filed, may reduce any earned patent term adjustment. See 37 CFR 1.704(b).

**NOTICE OF APPEAL**

2.  The Notice of Appeal was filed on \_\_\_\_\_. A brief in compliance with 37 CFR 41.37 must be filed within two months of the date of filing the Notice of Appeal (37 CFR 41.37(a)), or any extension thereof (37 CFR 41.37(e)), to avoid dismissal of the appeal. Since a Notice of Appeal has been filed, any reply must be filed within the time period set forth in 37 CFR 41.37(a).

**AMENDMENTS**

3.  The proposed amendment(s) filed after a final rejection, but prior to the date of filing a brief, will not be entered because  
(a)  They raise new issues that would require further consideration and/or search (see NOTE below);  
(b)  They raise the issue of new matter (see NOTE below);  
(c)  They are not deemed to place the application in better form for appeal by materially reducing or simplifying the issues for appeal; and/or  
(d)  They present additional claims without canceling a corresponding number of finally rejected claims.

NOTE: See Continuation Sheet. (See 37 CFR 1.116 and 41.33(a)).

4.  The amendments are not in compliance with 37 CFR 1.121. See attached Notice of Non-Compliant Amendment (PTOL-324).  
5.  Applicant's reply has overcome the following rejection(s): \_\_\_\_\_.  
6.  Newly proposed or amended claim(s) \_\_\_\_\_ would be allowable if submitted in a separate, timely filed amendment canceling the non-allowable claim(s).  
7.  For purposes of appeal, the proposed amendment(s): a)  will not be entered, or b)  will be entered and an explanation of how the new or amended claims would be rejected is provided below or appended.  
The status of the claim(s) is (or will be) as follows:  
Claim(s) allowed: \_\_\_\_\_.  
Claim(s) objected to: \_\_\_\_\_.  
Claim(s) rejected: \_\_\_\_\_.  
Claim(s) withdrawn from consideration: \_\_\_\_\_.

**AFFIDAVIT OR OTHER EVIDENCE**

8.  The affidavit or other evidence filed after a final action, but before or on the date of filing a Notice of Appeal will not be entered because applicant failed to provide a showing of good and sufficient reasons why the affidavit or other evidence is necessary and was not earlier presented. See 37 CFR 1.116(e).  
9.  The affidavit or other evidence filed after the date of filing a Notice of Appeal, but prior to the date of filing a brief, will not be entered because the affidavit or other evidence failed to overcome all rejections under appeal and/or appellant fails to provide a showing of a good and sufficient reasons why it is necessary and was not earlier presented. See 37 CFR 41.33(d)(1).  
10.  The affidavit or other evidence is entered. An explanation of the status of the claims after entry is below or attached.

**REQUEST FOR RECONSIDERATION/OTHER**

11.  The request for reconsideration has been considered but does NOT place the application in condition for allowance because: \_\_\_\_\_  
12.  Note the attached Information Disclosure Statement(s). (PTO/SB/08 or PTO-1449) Paper No(s): \_\_\_\_\_  
13.  Other: \_\_\_\_\_

*Joseph R. Pokrzywa*  
Joseph R. Pokrzywa  
Primary Examiner  
Art Unit: 2622

Continuation of 3. NOTE: The amendment to claims 43, 51, and 55 adds limitations that require "a memory associated with the processor for collecting" and storing the image data signal", and " the processor adapted for recalling the image data signal for viewing and transmission". These features, while overcoming the previously cited rejection, raise new issues that require further consideration and search.

JOSEPH R. POKRZYWA  
PRIMARY EXAMINER  
ART UNIT 2622  
*Joseph R Pokrzywa*





IN THE UNITED STATES PATENT AND TRADEMARK OFFICE

|                                      |   |                              |
|--------------------------------------|---|------------------------------|
| In re Application of:                | § |                              |
|                                      | § |                              |
| David A. Monroe                      | § | Group Art Unit: 2622         |
|                                      | § |                              |
| Serial No.: 10/336,470               | § | Examiner: Joseph R. Pokrzywa |
|                                      | § |                              |
| Filed: January 3, 2003               | § | Docket No. 121817.0002.042   |
|                                      | § |                              |
| For: <b>APPARATUS FOR CAPTURING,</b> | § |                              |
| <b>CONVERTING AND</b>                | § |                              |
| <b>TRANSMITTING A VISUAL</b>         | § |                              |
| <b>IMAGE SIGNAL VIA A DIGITAL</b>    | § |                              |
| <b>TRANSMISSION SYSTEM</b>           | § |                              |

Commissioner for Patents  
P.O. Box 1450  
Alexandria, Virginia 22313-1450

**RESPONSE TO FINAL ACTION DATED 08/09/2005**

Sir:

This is a response to the Final Action mailed on 08/09/2005. It amends the claims to place them in condition for allowance and it is respectfully requested that this response be entered and a Notice of Allowance be issued. In the alternative, it is respectfully requested that this response be entered in order to place the application in better condition for purposes of appeal.

Please amend the application as follows:

**Amendments to the Specification** begin on page 2 of this paper.

**Amendments to the Claims** are reflected in the listing of the claims which begin on page 3 of this paper.

**Remarks** begin on page 9 of this paper.

**Amendments to the Specification:**

Please replace paragraph [0049] with the following amended paragraph:

[0049] Turning now to Fig. 1, the simplest embodiment of the invention

DO NOT  
ENTER.  
J.P.  
10/9/05

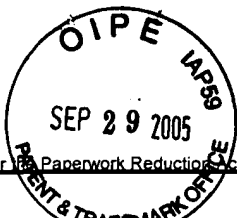

09/30/05

AP

DFW

PTO/SB/21 (09-04)

Approved for use through 07/31/2006. OMB 0651-0031  
U.S. Patent and Trademark Office; U.S. DEPARTMENT OF COMMERCE

Under the Paperwork Reduction Act of 1995, no persons are required to respond to a collection of information unless it displays a valid OMB control number.

|  |                      |  |
|--|----------------------|--|
| <b>TRANSMITTAL FORM</b><br><small>(to be used for all correspondence after initial filing)</small> | Application Number   | 10/336,470                               |
|  | Filing Date          | January 3, 2004                          |
|  | First Named Inventor | David A. Monroe                          |
|  | Art Unit             | 2622                                     |
|  | Examiner Name        | Joseph R. Pokrzywa                       |
| Total Number of Pages in This Submission   | 17                   | Attorney Docket Number<br>121817.002.042 |

| ENCLOSURES (Check all that apply)   |  |  |
|---|--|--|
| <input type="checkbox"/> Fee Transmittal Form                             | <input type="checkbox"/> Drawing(s)  | <input type="checkbox"/> After Allowance Communication to TC                               |
| <input type="checkbox"/> Fee Attached                                     | <input type="checkbox"/> Licensing-related Papers  | <input type="checkbox"/> Appeal Communication to Board of Appeals and Interferences        |
| <input checked="" type="checkbox"/> Amendment/Reply                       | <input type="checkbox"/> Petition  | <input type="checkbox"/> Appeal Communication to TC (Appeal Notice, Brief, Reply Brief)    |
| <input checked="" type="checkbox"/> After Final                           | <input type="checkbox"/> Petition to Convert to a Provisional Application                  | <input type="checkbox"/> Proprietary Information   |
| <input type="checkbox"/> Affidavits/declaration(s)                        | <input type="checkbox"/> Power of Attorney, Revocation<br>Change of Correspondence Address | <input type="checkbox"/> Status Letter   |
| <input type="checkbox"/> Extension of Time Request                        | <input type="checkbox"/> Terminal Disclaimer   | <input checked="" type="checkbox"/> Other Enclosure(s) (please identify below):            |
| <input type="checkbox"/> Express Abandonment Request                      | <input type="checkbox"/> Request for Refund  | Fee Address Indication Form, Change of Correspondence Address, and Acknowledgment Postcard |
| <input type="checkbox"/> Information Disclosure Statement                 | <input type="checkbox"/> CD, Number of CD(s) _____   |  |
| <input type="checkbox"/> Certified Copy of Priority Document(s)           | <input type="checkbox"/> Landscape Table on CD   |  |
| <input type="checkbox"/> Reply to Missing Parts/ Incomplete Application   | Remarks  |  |
| <input type="checkbox"/> Reply to Missing Parts under 37 CFR 1.52 or 1.53 |  |  |

| SIGNATURE OF APPLICANT, ATTORNEY, OR AGENT |                    |          |        |
|--|--------------------|----------|--------|
| Firm Name                                  |                    |          |        |
| Signature                                  |                    |          |        |
| Printed name                               | Robert C. Curfiss  |          |        |
| Date                                       | September 29, 2005 | Reg. No. | 26,540 |

| CERTIFICATE OF TRANSMISSION/MAILING  |                    |
|--|--------------------|
| I hereby certify that this correspondence is being facsimile transmitted to the USPTO or deposited with the United States Postal Service with sufficient postage as first class mail in an envelope addressed to: Commissioner for Patents, P.O. Box 1450, Alexandria, VA 22313-1450 on the date shown below: <i>Express Mail # EA 09096621945</i> |                    |
| Signature  |                    |
| Typed or printed name  | Judith Ann Kruger  |
| Date   | September 29, 2005 |

This collection of information is required by 37 CFR 1.5. The information is required to obtain or retain a benefit by the public which is to file (and by the USPTO to process) an application. Confidentiality is governed by 35 U.S.C. 122 and 37 CFR 1.11 and 1.14. This collection is estimated to 2 hours to complete, including gathering, preparing, and submitting the completed application form to the USPTO. Time will vary depending upon the individual case. Any comments on the amount of time you require to complete this form and/or suggestions for reducing this burden, should be sent to the Chief Information Officer, U.S. Patent and Trademark Office, U.S. Department of Commerce, P.O. Box 1450, Alexandria, VA 22313-1450. DO NOT SEND FEES OR COMPLETED FORMS TO THIS ADDRESS. SEND TO: Commissioner for Patents, P.O. Box 1450, Alexandria, VA 22313-1450.

If you need assistance in completing the form, call 1-800-PTO-9199 and select option 2.



IN THE UNITED STATES PATENT AND TRADEMARK OFFICE

In re Application of: §  
David A. Monroe § Group Art Unit: 2622  
Serial No.: 10/336,470 § Examiner: Joseph R. Pokrzywa  
Filed: January 3, 2003 § Docket No. 121817.0002.042  
For: **APPARATUS FOR CAPTURING, §  
CONVERTING AND §  
TRANSMITTING A VISUAL §  
IMAGE SIGNAL VIA A DIGITAL §  
TRANSMISSION SYSTEM §**

Commissioner for Patents  
P.O. Box 1450  
Alexandria, Virginia 22313-1450

**RESPONSE TO FINAL ACTION DATED 08/09/2005**

Sir:

This is a response to the Final Action mailed on 08/09/2005. It amends the claims to place them in condition for allowance and it is respectfully requested that this response be entered and a Notice of Allowance be issued. In the alternative, it is respectfully requested that this response be entered in order to place the application in better condition for purposes of appeal.

Please amend the application as follows:

**Amendments to the Specification** begin on page 2 of this paper.

**Amendments to the Claims** are reflected in the listing of the claims which begin on page 3 of this paper.

**Remarks** begin on page 9 of this paper.

**Amendments to the Specification:**

Please replace paragraph [0049] with the following amended paragraph:

[0049] Turning now to Fig. 1, the simplest embodiment of the invention

incorporates a standard analog or digital camera device 10 for capturing a visual image in the typical fashion. The camera 10 may be operator activated as indicated at 12, or may be programmed to be activated at selected intervals or in response to certain conditions. For example, a motion detector may be utilized to activate the camera 10 in a surveillance installation. Once activated, the camera 10 captures a visual image in typical fashion through a lens (see lens 192, for example, in Fig. 7A). In the illustrated embodiment, the captured image is then transmitted to a gray scale bit map memory device 16, from which it is output to a half-tone conversion scheme 18 to be input into a binary bit map 20 for formatting the captured image in a configuration suitable for transmission via a Group-III facsimile system. The signal generated at 22 by the binary bit map 20 is input into a Group-III encoding and compression network 24 for generating an output signal at 26 which is introduced into a Group III protocol transmission device 28. The output at 30 of the transmission device 28 is then transmitted into any standard transmission interface such as, by way of example, hard line telephonic transmission, cellular transmission, radio signal, satellite transmission or other transmission system 32 via a modem or similar device, as needed (~~as diagrammatically illustrated at 29~~), to be received via a compatible interface by a remote Group-III receiving system 34. The Group III receiving system 34 is a typical Group-III facsimile system comprising a Group-III receiver 36, decoder and decompressor 38 and binary bit map 40, from which a facsimile hard copy such as plain paper copy 42 may be generated.

**Amendments to the Claims:**

This listing of claims will replace all prior versions, and listings, of claims in the application:

**Listing of Claims:**

1. (Cancelled)
2. (Cancelled)
3. (Cancelled)
4. (Cancelled)
5. (Cancelled)
6. (Cancelled)
7. (Cancelled)
8. (Cancelled)
9. (Cancelled)
10. (Cancelled)
11. (Cancelled)
12. (Cancelled)
13. (Cancelled)
14. (Cancelled)
15. (Cancelled)
16. (Cancelled)
17. (Cancelled)
18. (Cancelled)
19. (Cancelled)
20. (Cancelled)
21. (Cancelled)
22. (Cancelled)
23. (Cancelled)
24. (Cancelled)
25. (Cancelled)
26. (Cancelled)
27. (Cancelled)

28. (Cancelled)
29. (Cancelled)
30. (Cancelled)
31. (Cancelled)
32. (Cancelled)
33. (Cancelled)
34. (Cancelled)
35. (Cancelled)
36. (Cancelled)
37. (Cancelled)
38. (Cancelled)
39. (Cancelled)
40. (Cancelled)
41. (Cancelled).
42. (Cancelled)

43. (Currently Amended) A handheld self-contained cellular telephone and integrated image processing system both of which are carried in a common case for both sending and receiving telephonic audio signals and for capturing a visual image and transmitting it to a compatible remote receiving station, the system comprising:

- a. A housing defining the common case;
- b. An image capture device comprising a electronic camera contained within the housing;
- c. A display for displaying an image framed by the camera;
- d. A processor in the housing for generating an image data signal representing the image framed by the camera;
- e. A memory associated with the processor for collecting and storing the image data signal;
- f. The processor adapted for recalling the image data signal for viewing and transmission;
- g. A telephonic system in the housing for sending and receiving digitized audio signals and adapted for sending the image data signal;

- h. Alphanumeric input keys in the housing for permitting manually input digitized alphanumeric signals to be input to the processor, the telephonic system being further adapted for sending the digitized alphanumeric signals;
- i. A wireless communications device adapted for transmitting any of the digitized signals to the [a] compatible remote receiving station; and
- j. A power supply in the housing for powering the system.

44. (Currently Amended) The self-contained image processing system of Claim 43, wherein the [further comprising a] display for framing the image to be captured by the image capture device is adapted [and] for displaying the image at the system whereby the image [operator] can be viewed [view] and framed [frame the image] prior to capture in the memory.

45. (Previously presented) The self-contained image processing system of Claim 43, wherein the display is adapted for viewing alphanumeric messages input at the alphanumeric keys.

46. (Cancelled)

47. (Cancelled)

48. (Currently Amended) The self-contained image processing system of Claim 43, further comprising a removable memory module in addition to the memory, said removable memory adapted to be removably housed in the housing for storing captured image data signals.

49. (Cancelled)

50. (Currently Amended) The self-contained image processing system of Claim 43 [49], wherein the display is adapted for viewing incoming image data signals.

51. (Currently Amended) A handheld cellular telephone having an integrated electronic camera in a common case for both sending and receiving telephonic audio signals and for capturing a visual image, converting the visual image to a digitized image data signal and transmitting digitized image data signal via a cellular telephone network, the cellular telephone comprising:

- a. A housing defining the common case;
- b. A cellular telephone in the housing, the cellular telephone further including a transmitter/receiver for transmitting and receiving audio telephone messages over a cellular telephone network, a keypad for entering manually input alphanumeric signals to be transmitted over the cellular telephone network, and a display window for viewing the manually input alphanumeric signals;
- c. An electronic camera in the housing, the digitized camera adapted for visually framing a visual image to be captured;
- d. A processor associated with the electronic camera for capturing and digitizing the framed image in a format adapted for transmission over the cellular telephone network via the cellular telephone;
- e. A memory associated with the processor for receiving and storing the digitized framed image for selectively displaying it in the display window and transmitting it over the cellular telephone network; and
- f. An integrated power supply for powering both the cellular telephone and the camera.

52. (Currently Amended) The cellular telephone of Claim 51, wherein the display window for viewing the alphanumeric signals is within the display window for framing the visual image.

53. (Cancelled)

54. (Currently Amended) The cellular telephone of Claim 51 [53], further including a second [wherein the] memory [is] selectively removable from the housing.

55. (Currently Amended) A combination of handheld cellular telephone and electronic camera in a unitary case comprising:



- a. A housing defining the case;
- b. A electronic camera in the housing;
- c. A display in the housing for framing the image to be captured by an image capture device and for viewing the image whereby an operator can view and frame the image prior to capture;
- d. A processor for processing the image framed by the camera for generating a digitized framed image as displayed in the display;
- e. A memory associated with the processor for receiving and storing the digitized framed image for selectively displaying it in the display window and transmitting it over a cellular telephone network;
- f. A cellular telephone in the housing and adapted for accepting and digitizing audio signals to be transmitted and for converting received digitized audio signals into acoustic audio, the cellular telephone further adapted for transmitting and receiving non-audio digital signals including digitized image signals;
- g. Alphanumeric input keys in the housing for permitting manually input alphanumeric signals to be input into the cellular telephone, the manually input alphanumeric signals being presented in the [a] display;
- h. A power supply in the housing for powering the processor, the cellular telephone, the display and the camera; and
- i. A wireless transmitter/receiver in the housing for transmitting digital signals sent from and receiving digital signals sent to the cellular telephone.

56. (Cancelled)

57. (Cancelled)

58. (Cancelled)

59. (Cancelled)

60. (Previously presented) The combination of Claim 55, further comprising a removable memory module adapted to be removably housed in the housing for storing captured image data signals.

61. (Cancelled)

62. (Currently Amended) The combination of Claim 55 [60] wherein the display is adapted for viewing incoming image data signals.

## REMARKS

Applicant appreciates the thorough and thoughtful response mailed on August 9, 2005 and respectfully requests that the Examiner enter this amendment after Final Rejection, placing the application in condition for allowance or in the alternative placing the case in better condition for purposes of appeal.

Applicant and his attorney appreciate the interview granted on September 22, 2005 during which applicant indicated that he would cancel claims 1-42 and modify claims 43-62 to overcome the rejections made by the Examiner. The interview discussion was directed primarily to the Collett reference, U.S. Patent No. 5,517,683, as that patent was the primary reference forming the basis for the rejection of claims 43-62.

As was discussed in the interview, while Collett shows an illustration of a proposed camera attachment to be mounted on the phone in Figs. 7a and 7b, Collett does not disclose how such a camera would operate, stating only "the addition of conventional video display control electronics" (Col. 8, lines 23-25), with no disclosure or discussion of what is meant by the term "conventional video electronics."

As applicant stated in earlier amendments and his affidavit, it was the creation of the electronics that made the invention possible. There were not any "conventional video electronics" suitable for use in a cellular telephone environment when Collett was filed. This is borne out by the fact that Collett did not disclose any.

Applicant has amended Claims 43-62 to clearly distinguish what applicant believes to be his invention and to properly distinguish over Collett.

In addition to the cancellation of Claims 1-42, Claims 46, 47, 49, 53, 56-59 and 61 have also been cancelled.

The Claims currently pending in the case are Claims 43-45, 48, 50-52, 54, 55, 60 and 62, as amended or previously presented herein.

## Claim Rejections

### Amended Claims Summary

Claims 1-4, 7-9, 12, 13, 18-20, 22-30, 35-42, 46, 47, 49, 58, 59 and 61 were rejected by the Examiner in the Office Action dated August 9, 2005. These claims have been cancelled, rendering moot the rejections thereto.

### Claim 43 (Currently Amended)

Claim 43 is rejected under 35 USC §102(b). It is respectfully submitted that Collett does not disclose a camera and cell phone in a common case as now called for in Claim 43 (Currently Amended). Nor does it suggest how this might be accomplished, in fact indicating that the camera would be coupled to a connector provided on the cell phone. In addition Collett does not disclose any of the electronics required to frame, capture, process and store and image for retrieval and transmission as now called for in Claim 43. It is respectfully submitted that Claim 43, as now amended, overcomes the Collett reference and the other art of record. Therefore, it is respectfully submitted that Claim 43 (Currently Amended) is now in condition for allowance.

### Claims 44, 45, 48 and 50 (As currently amended)

These Claims were also rejected under 35 USC §102(b) over Collett. It is respectfully that these claims, now depending from an allowable base Claim 43 (Currently Amended), are allowable over Collett for the same reasons as set forth with respect to Claim 43 (Currently Amended).

### Claim 51 (Currently Amended)

Claim 51 is rejected under 35 USC §102(b). It is respectfully submitted that Collett does not disclose a camera and cell phone in a common case as now called for in Claim 51 (Currently Amended). Nor does it suggest how this might be accomplished, in fact indicating that the camera would be coupled to a connector provided on the cell phone. In addition Collett does not disclose any of the electronics required to frame, capture, process and store and image for retrieval and transmission as now called for in Claim 51. It is respectfully submitted that Claim 51, as now amended, overcomes the Collett reference and the other art of record. Therefore, it is respectfully submitted that Claim 51 (Currently Amended) is now in condition for allowance.

Claims 52 and 54 (As currently amended)

These Claims were also rejected under 35 USC §102(b) over Collett. It is respectfully that these claims, now depending from an allowable base Claim 51(Currently Amended), are allowable over Collett for the same reasons as set forth with respect to Claim 51(Currently Amended).

Claim 55(Currently Amended)

Claim 55 is rejected under 35 USC §102(b). It is respectfully submitted that Collett does not disclose a camera and cell phone in a common case as now called for in Claim 55(Currently Amended). Nor does it suggest how this might be accomplished, in fact indicating that the camera would be coupled to a connector provided on the cell phone. In addition Collett does not disclose any of the electronics required to frame, capture, process and store and image for retrieval and transmission as now called for in Claim 55. It is respectfully submitted that Claim 55, as now amended, overcomes the Collett reference and the other art of record. Therefore, it is respectfully submitted that Claim 55(Currently Amended) is now in condition for allowance.

Claims 60 and 62 (As currently amended)

These Claims were also rejected under 35 USC §102(b) over Collett. It is respectfully that these claims, now depending from an allowable base Claim 55(Currently Amended), are allowable over Collett for the same reasons as set forth with respect to Claim 55(Currently Amended).

## Drawing Objections

### Amended Drawing Summary

The Examiner in the Office Action dated August 9, 2005 stated that the replacement sheets were unacceptable because they were unreadable, faded, and blurred. The enclosed replacement sheets for Figs. 4 and 5 are now readable and Applicant therefore believes such sheets are in condition for allowance and respectfully requests they be passed to allowance.

The Examiner further stated that the drawings were objected to because they do not include reference numeral "29" that appears in paragraph 0049, line 18. This reference numeral has been deleted from the paragraph per the amendment of the specification on page 2 of this document. As such, Applicant believes this objection should be removed and respectfully requests the drawings be allowed.

A number of other objections to the drawings were corrected in a Supplementary Amendment filed on May 17, 2005.

**CONCLUSION**

Applicant and his attorney appreciate the courtesies extended by the Examiner at the interview of September 21, 2005.

As will be noted by the Examiner, the claims have been substantially amended in view of the art first cited by the Examiner in the Final Office Action of August 9, 2005. The claims are now more clearly directed to and distinctly point out what applicant believes to be his invention.

Moreover, the subject invention, as supported by the claims as amended are distinct from the art of record. It is respectfully submitted that each of the independent Claims 43(Currently Amended), 51(Currently Amended) and 55(Currently Amended) are now in condition to be allowed.

It is also respectfully submitted that the dependent claims are allowable for the same reasons. It is, therefore, respectfully requested that the Examiner withdraw his rejections of the claims and place this application in condition for allowance.

The objection to the drawings has been noted and will be corrected concurrent with the filing of this Amendment.

All of the objections and rejections of the Examiner having been met by the amendments made herein, it is respectfully requested that this case be passed to allowance.

Respectfully submitted,

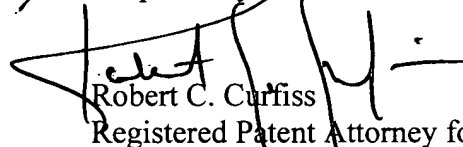

Robert C. Curfiss  
Registered Patent Attorney for Applicant  
Reg. No. 26,540  
(832) 573-1442

Please send all correspondences to:  
Robert C. Curfiss  
P.O. Box 903  
Humble, Texas 77347

**CERTIFICATE OF EXPRESS MAILING**

I hereby certify that this paper (along with any paper referred to as being attached or enclosed) is being deposited on the date shown below with the United States Postal Service, via Express Mail No. EQ090966219 US (37 CFR 1.10), in an envelope addressed to Mail Stop AF, Commissioner for Patents, P.O. Box 1450, Alexandria, VA 22313-1450.

September 29, 2005

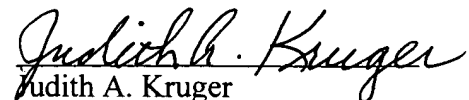

Judith A. Kruger

Replacement Sheet

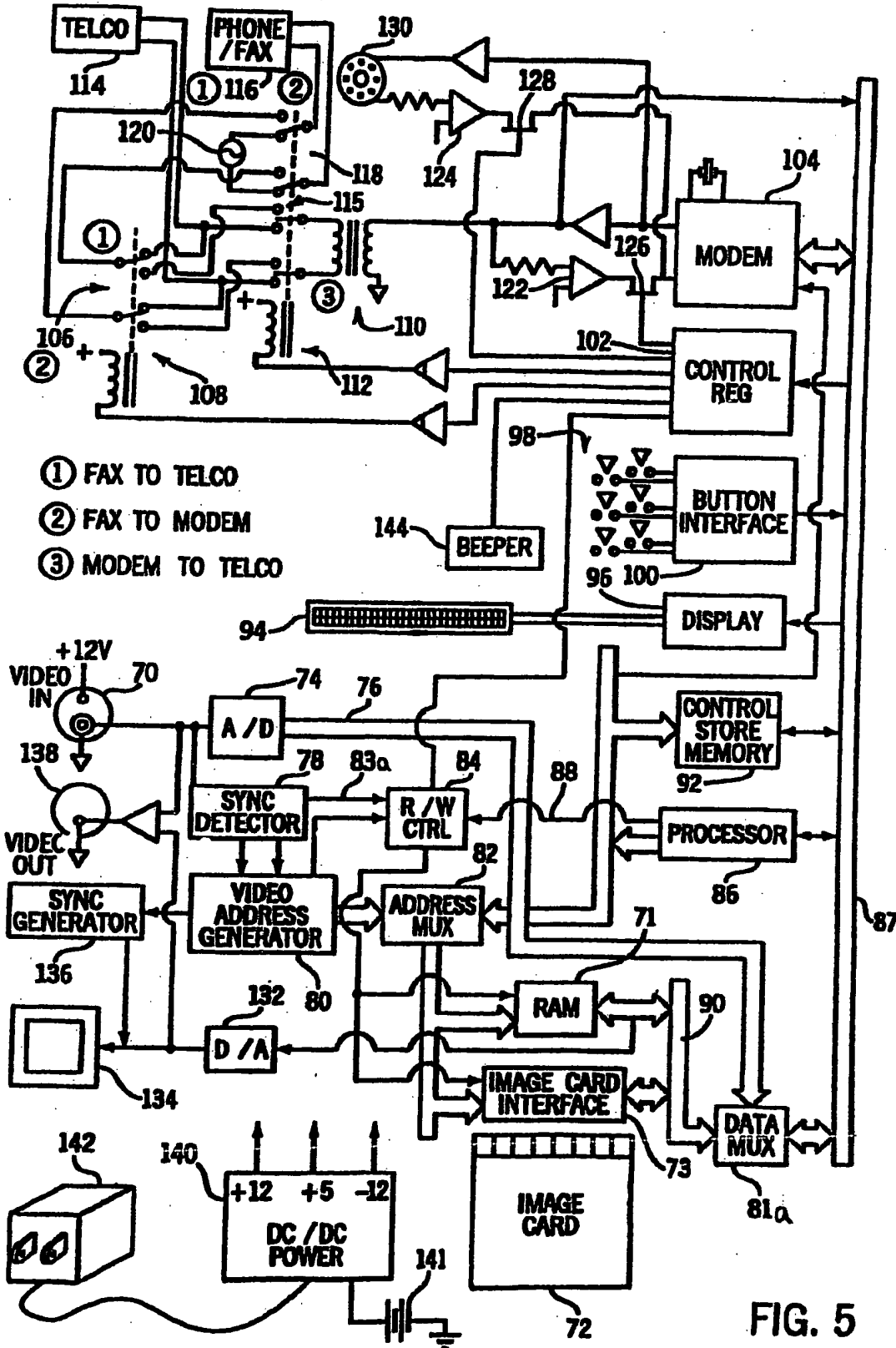
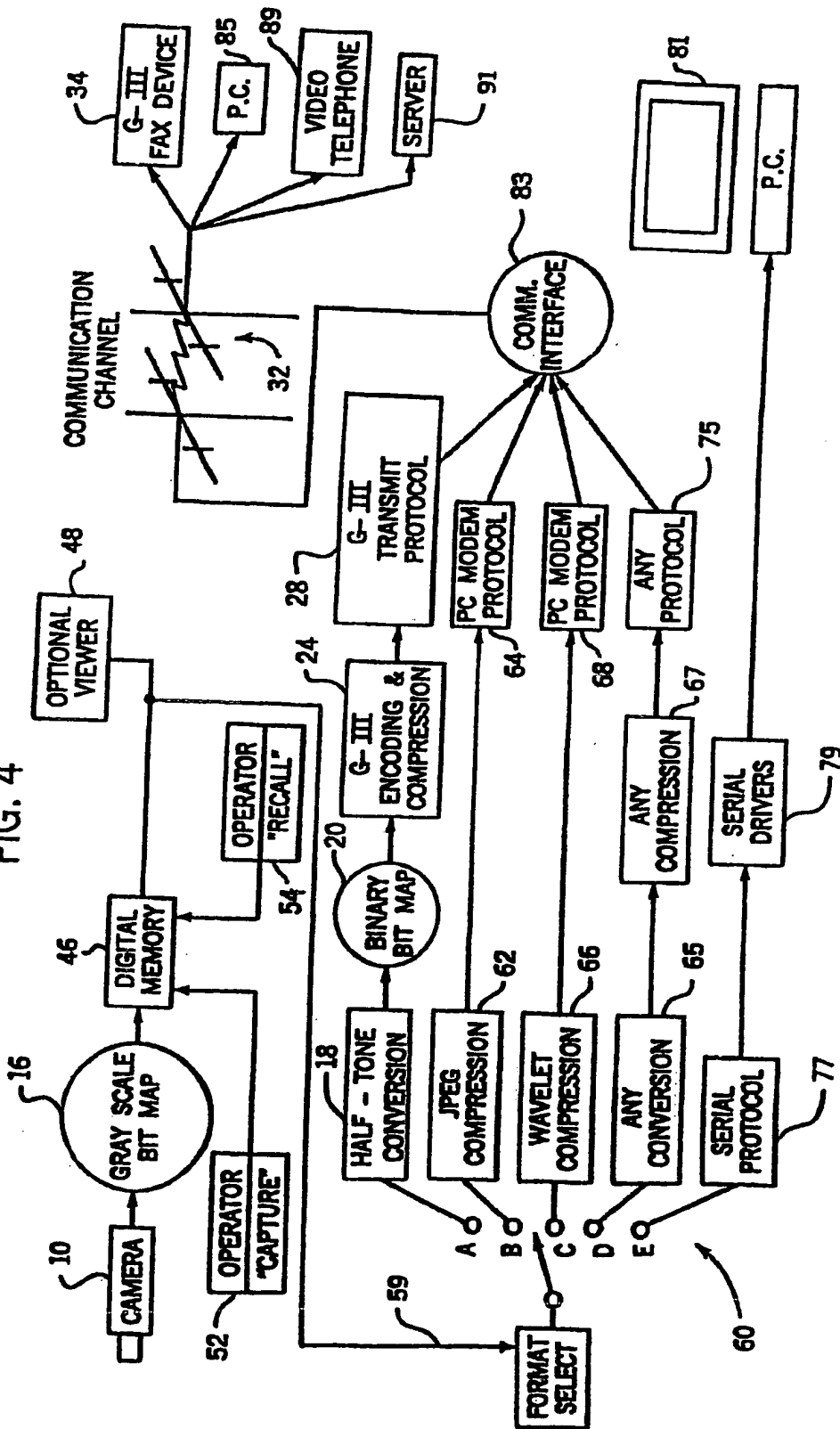

FIG. 5



FIG. 4





UNITED STATES PATENT AND TRADEMARK OFFICE

UNITED STATES DEPARTMENT OF COMMERCE  
United States Patent and Trademark Office  
Address: COMMISSIONER FOR PATENTS  
P.O. Box 1450  
Alexandria, Virginia 22313-1450  
www.uspto.gov

*PW*

| APPLICATION NO. | FILING DATE | FIRST NAMED INVENTOR | ATTORNEY DOCKET NO. | CONFIRMATION NO. |
|-----------------|-------------|----------------------|---------------------|------------------|
| 10/336,470      | 01/03/2003  | David A. Monroe      | 121817.0002.042     | 8448             |

7590 08/09/2005  
**Robert C Curfiss**  
**JACKSON WALKER L.L.P.**  
 112 E. Pecan Street, Suite 2100  
 San Antonio, TX 78205

EXAMINER

POKRZYWA, JOSEPH R

| ART UNIT | PAPER NUMBER |
|----------|--------------|
| 2622     |              |

2622

DATE MAILED: 08/09/2005

Please find below and/or attached an Office communication concerning this application or proceeding.

|                              |                                       |   |  |
|------------------------------|---------------------------------------|---|--|
| <b>Office Action Summary</b> | <b>Application No.</b><br>10/336,470  | <b>Applicant(s)</b><br>MONROE, DAVID A. |  |
|                              | <b>Examiner</b><br>Joseph R. Pokrzywa | <b>Art Unit</b><br>2622                 |  |

-- The MAILING DATE of this communication appears on the cover sheet with the correspondence address --

**Period for Reply**

A SHORTENED STATUTORY PERIOD FOR REPLY IS SET TO EXPIRE 3 MONTH(S) FROM THE MAILING DATE OF THIS COMMUNICATION.

- Extensions of time may be available under the provisions of 37 CFR 1.136(a). In no event, however, may a reply be timely filed after SIX (6) MONTHS from the mailing date of this communication.
- If the period for reply specified above is less than thirty (30) days, a reply within the statutory minimum of thirty (30) days will be considered timely.
- If NO period for reply is specified above, the maximum statutory period will apply and will expire SIX (6) MONTHS from the mailing date of this communication.
- Failure to reply within the set or extended period for reply will, by statute, cause the application to become ABANDONED (35 U.S.C. § 133). Any reply received by the Office later than three months after the mailing date of this communication, even if timely filed, may reduce any earned patent term adjustment. See 37 CFR 1.704(b).

**Status**

- 1)  Responsive to communication(s) filed on 20 May 2005.
- 2a)  This action is **FINAL**.                      2b)  This action is non-final.
- 3)  Since this application is in condition for allowance except for formal matters, prosecution as to the merits is closed in accordance with the practice under *Ex parte Quayle*, 1935 C.D. 11, 453 O.G. 213.

**Disposition of Claims**

- 4)  Claim(s) 1-4, 7-9, 12, 13, 18-20, 22-30 and 35-62 is/are pending in the application.  
4a) Of the above claim(s) \_\_\_\_\_ is/are withdrawn from consideration.
- 5)  Claim(s) \_\_\_\_\_ is/are allowed.
- 6)  Claim(s) 1-4, 7-9, 12, 13, 18-20, 22-30 and 35-62 is/are rejected.
- 7)  Claim(s) \_\_\_\_\_ is/are objected to.
- 8)  Claim(s) \_\_\_\_\_ are subject to restriction and/or election requirement.

**Application Papers**

- 9)  The specification is objected to by the Examiner.
- 10)  The drawing(s) filed on 20 May 2005 is/are: a)  accepted or b)  objected to by the Examiner.  
Applicant may not request that any objection to the drawing(s) be held in abeyance. See 37 CFR 1.85(a).  
Replacement drawing sheet(s) including the correction is required if the drawing(s) is objected to. See 37 CFR 1.121(d).
- 11)  The oath or declaration is objected to by the Examiner. Note the attached Office Action or form PTO-152.

**Priority under 35 U.S.C. § 119**

- 12)  Acknowledgment is made of a claim for foreign priority under 35 U.S.C. § 119(a)-(d) or (f).  
a)  All    b)  Some \*    c)  None of:
1.  Certified copies of the priority documents have been received.
2.  Certified copies of the priority documents have been received in Application No. \_\_\_\_\_.
3.  Copies of the certified copies of the priority documents have been received in this National Stage application from the International Bureau (PCT Rule 17.2(a)).

\* See the attached detailed Office action for a list of the certified copies not received.

**Attachment(s)**

- |  |   |
|--|---|
| 1) <input checked="" type="checkbox"/> Notice of References Cited (PTO-892)  | 4) <input type="checkbox"/> Interview Summary (PTO-413)<br>Paper No(s)/Mail Date. _____ |
| 2) <input type="checkbox"/> Notice of Draftsperson's Patent Drawing Review (PTO-948)                                   | 5) <input type="checkbox"/> Notice of Informal Patent Application (PTO-152)             |
| 3) <input type="checkbox"/> Information Disclosure Statement(s) (PTO-1449 or PTO/SB/08)<br>Paper No(s)/Mail Date _____ | 6) <input type="checkbox"/> Other: _____  |

## DETAILED ACTION

### *Response to Amendment*

1. Applicant's amendments were received on 5/20/05 and 5/2/05, and have been entered and made of record. Currently, **claims 1-4, 7-9, 12, 13, 18-20, 22-30, and 35-62** are pending.

### *Response to Affidavit under 37 CFR 1.131*

2. The affidavit filed on 1/6/05 under 37 CFR 1.131 is sufficient to overcome the cited references of Wertsberger (U.S. Patent Number 6,072,600), Parulski *et al.* (U.S. Patent Number 5,666,159), Shibata *et al.* (U.S. Patent Number 5,689,300), and Bradley *et al.* (U.S. Patent Number 5,995,041).

3. However, the affidavit is ineffective to overcome the references of Hassan *et al.* (U.S. Patent Number 5,550,646) and Ross (U.S. Patent Number 5,546,194).

4. These two references, as well as the additional references that are noted in this Office action, are cited under 35 U.S.C. 102(b), which is a statutory bar under 35 U.S.C. 102(b), and thus cannot be overcome by an affidavit or declaration under 37 CFR 1.131.

### *Drawings*

5. The drawings were received on 5/20/05. These drawings are unacceptable by the examiner. The replacement sheets that were submitted are unreadable, as many of the lines and lettering within the drawings are faded and blurred due to numerous copies of the images.

Therefore, the objection to the drawings remains, and will be repeated hereinbelow.

Art Unit: 2622

6. The drawings are objected to as failing to comply with 37 CFR 1.84(p)(4) because reference character "81" has been used to designate both the hardwired personal computer in Fig. 4 and the data multiplexer circuit in Fig. 5, and reference character "83" has been used to designate both the communications interface module in Fig. 4 and the sync signal in Fig. 5.

7. The drawings are objected to as failing to comply with 37 CFR 1.84(p)(5) because they do not include the following reference sign(s) mentioned in the description: reference numeral "29", in paragraph 0049, line 18.

8. The drawings are objected to because in Fig. 4, PC modem protocol box "66" should read "68", as read in paragraph 0053, lines 20 and 21.

9. Corrected drawing sheets in compliance with 37 CFR 1.121(d) are required in reply to the Office action to avoid abandonment of the application. Any amended replacement drawing sheet should include all of the figures appearing on the immediate prior version of the sheet, even if only one figure is being amended. The figure or figure number of an amended drawing should not be labeled as "amended." If a drawing figure is to be canceled, the appropriate figure must be removed from the replacement sheet, and where necessary, the remaining figures must be renumbered and appropriate changes made to the brief description of the several views of the drawings for consistency. Additional replacement sheets may be necessary to show the renumbering of the remaining figures. The replacement sheet(s) should be labeled "Replacement Sheet" in the page header (as per 37 CFR 1.84(c)) so as not to obstruct any portion of the drawing figures. If the changes are not accepted by the examiner, the applicant will be notified and informed of any required corrective action in the next Office action. The objection to the drawings will not be held in abeyance.

***Response to Arguments***

10. Applicant's arguments filed 5/2/05, with respect to the reference of Hassan *et al.*, which was cited in the Office action dated 9/27/04 as anticipating claim 1, have been fully considered but they are not persuasive.

In response to applicant's arguments dated 5/2/05 regarding the rejection of independent claim 1, wherein applicant argues on pages 16 and 17 that Hassan fails to teach of how using a cellular line is implemented, thus failing to teach of "a self-contained image processing system...for capturing a visual image and transmitting it to a remote receiving station ... a processor ... a communications device...adapted for transmitting the data signal to the remote receiving station and a wireless transmission system between the communications device and the compatible receiving station".

As read in column 2, lines 49-54, Hassan states that "the image capture device can be connected or gain access to a telecommunications network, such as by being connected to an ordinary telephone jack 130 by a telephone line 131, or being connected to a cellular telephone arranged to establish an over the air communications link." With this, Hassan teaches that the image capture device 110, seen in Fig. 1, can be connected to a cellular telephone, instead of the ordinary telephone line and telephone jack seen in Fig. 1. Thus, an "air communications link" of the cellular telephone is being interpreted as "a wireless transmission system between the communication s device and the compatible receiving station", as currently required in claim 1. Further, as read in column 5, lines 7-9, Hassan teaches that "the output of fax modem 240 may be applied as an input to the transmitter section of a cellular telephone". This shows how Hassan implements the cellular network for the system.

Art Unit: 2622

11. Therefore, the rejection of independent **claim 1**, as well as the corresponding dependent claims, as cited in the Office action dated 9/27/04, under 35U.S.C.102(b), as being anticipated by Hassan *et al.*, is maintained and repeated in this Office action.

### *Claim Objections*

12. **Claims 44 and 56** are objected to because of the following informalities:

In **claim 44**, line 3, “the operator” should read “an operator”, as an operator is not previously introduced;

in **claim 56**, line 2, “image capture device” should read “electronic camera”; and

in line 3, “the operator” should read “an operator”.

Appropriate correction is required.

### *Claim Rejections - 35 USC § 112*

13. The following is a quotation of the first paragraph of 35 U.S.C. 112:

The specification shall contain a written description of the invention, and of the manner and process of making and using it, in such full, clear, concise, and exact terms as to enable any person skilled in the art to which it pertains, or with which it is most nearly connected, to make and use the same and shall set forth the best mode contemplated by the inventor of carrying out his invention.

14. **Claims 46, 47, 58, and 59** are rejected under 35 U.S.C. 112, first paragraph, as failing to comply with the written description requirement. The claim(s) contains subject matter which was not described in the specification in such a way as to reasonably convey to one skilled in the relevant art that the inventor(s), at the time the application was filed, had possession of the claimed invention. Particularly, the newly added limitations requiring “the display is adapted for viewing such incoming alpha numeric messages” and “the display is adapted for viewing such

Art Unit: 2622

incoming data signals”, whereby the incoming alphanumeric messages and the incoming data signals are received from a remote station, are features that were not described in the specification, as originally written.

15. The following is a quotation of the second paragraph of 35 U.S.C. 112:

The specification shall conclude with one or more claims particularly pointing out and distinctly claiming the subject matter which the applicant regards as his invention.

16. **Claims 49 and 61** are rejected under 35 U.S.C. 112, second paragraph, as being indefinite for failing to particularly point out and distinctly claim the subject matter which applicant regards as the invention.

17. Regarding **claims 49 and 61**, the phrase "such as" in line 4 of both claims renders the claims indefinite because it is unclear whether the limitations following the phrase are part of the claimed invention. See MPEP § 2173.05(d).

### ***Claim Rejections - 35 USC § 102***

18. The following is a quotation of the appropriate paragraphs of 35 U.S.C. 102 that form the basis for the rejections under this section made in this Office action:

A person shall be entitled to a patent unless –

(b) the invention was patented or described in a printed publication in this or a foreign country or in public use or on sale in this country, more than one year prior to the date of application for patent in the United States.

19. **Claims 1, 2, 4, 7-9, 12, 23-27, 30, 35, and 36** are rejected under 35 U.S.C. 102(b) as being anticipated by Hassan *et al.* (U.S. Patent Number 5,550,646, cited in the Office action dated 9/27/04).



Art Unit: 2622

Regarding *claim 1*, Hassan discloses a self-contained image processing system (device 110 in Figs. 1 and 2) for capturing a visual image and transmitting it to a remote receiving station (see abstract, column 1, lines 47 through 52, column 2, lines 43 through 61, and column 3, lines 10 through 20), with the system comprising an image capture device (CCD 203, column 3, lines 21 through 67), a processor (microcontroller 205) for generating a data signal representing the image (column 3, lines 21 through 67), a communications device (facsimile interface 219) adapted for transmitting the data signal to the remote receiving station (column 4, line 65 through column 5, line 9), and a wireless transmission system between the communications device and the compatible receiving station (column 2, lines 4 through 54, and column 3, lines 10 through 20, with the fax modem 240, being “applied as an input to the transmitter section of a cellular telephone”, as read in column 5, lines 7 through 9).

Regarding *claim 2*, Hassan discloses the system discussed above in claim 1, and further teaches of a memory for receiving and storing the data signal (RAM 207), and wherein the communications device is adapted for recalling the stored data signal from memory (column 4, lines 24 through 64).

Regarding *claim 4*, Hassan discloses the system discussed above in claim 1, and further teaches of the image capture device is an analog camera (lens assembly 201 on a CCD 203) for generating an analog image signal (column 3, lines 21 through 67), and there is further included an analog to digital converter for converting the analog image signal to a digital signal (column 3, line 47 through column 4, line 67).

Art Unit: 2622

Regarding *claim 7*, Hassan discloses the system discussed above in claim 1, and further teaches of an integrated wireless telephone associated with the communications device (column 2, lines 4 through 54).

Regarding *claim 8*, Hassan discloses the system discussed above in claim 1, and further teaches of a housing for housing all of the elements of the system in an integrated body (column 2, lines 39 through 66).

Regarding *claim 9*, Hassan discloses the system discussed above in claim 1, and further teaches that the image capture device is a digital camera (column 2, lines 39 through 67, and column 3, lines 21 through 46).

Regarding *claim 12*, Hassan discloses the system discussed above in claim 1, and further teaches that the processor is adapted for generating a signal in any of a plurality of selected protocols and wherein the communications device is adapted for transmitting the signal in the proper protocol to a remote, compatible receiving station (column 4, line 65 through column 5, line 10).

Regarding *claim 23*, Hassan discloses the system discussed above in claim 1, and further teaches of a data processor for creating a text data signal associated with the image data signal (column 4, lines 19 through 64).

Regarding *claim 24*, Hassan discloses the system discussed above in claim 23, and further teaches of an input device for providing text data to the data processor (keypad 211, column 4, lines 1 through 64).

Regarding *claim 25*, Hassan discloses the system discussed above in claim 24, and further teaches that the input device is user controlled (column 4, lines 1 through 64).

Art Unit: 2622

Regarding **claim 26**, Hassan discloses the system discussed above in claim 25, and further teaches that the user controlled input device is an integral keyboard (keypad 211, column 4, lines 1 through 18).

Regarding **claim 27**, Hassan discloses the system discussed above in claim 24, and further teaches that the input device comprises a real time clock (column 4, lines 24 through 42).

Regarding **claim 30**, Hassan discloses the system discussed above in claim 2, and further teaches that the image data signal is stored in a compressed format (column 3, lines 47 through 54).

Regarding **claim 35**, Hassan discloses the system discussed above in claim 1, and further teaches that the remote receiving station is a digital device and the image data is digital (column 2, line 45 through column 3, line 33, and column 4, line 65 through column 5, line 9).

Regarding **claim 36**, Hassan discloses the system discussed above in claim 1, and further teaches of a self-contained power source for powering the system (column 5, lines 23 through 25).

20. **Claims 1, 22, and 36-42** are rejected under 35 U.S.C. 102(b) as being anticipated by Hannon *et al.* (U.S. Patent Number 4,688,244).

Regarding **claim 1**, Hannon discloses a self-contained image processing system (security module 30, seen in Figs. 1 and 2) for capturing a visual image and transmitting it to a remote receiving station (column 6, lines 14-58), with the system comprising an image capture device (camera unit 84, column 7, lines 45-68), a processor for generating a data signal representing the image (column 7, lines 3-68), a communications device (real-time automatic dial cellular

Art Unit: 2622

telephone/modem unit 68) adapted for transmitting the data signal to the remote receiving station (column 6, lines 28-58, and column 10, lines 52-56), and a wireless transmission system between the communications device and the compatible receiving station (column 6, lines 28-58, and column 9, lines 60-66).

Regarding *claim 22*, Hannon discloses the system discussed above in claim 1, and further teaches of an audio signal capture device adapted for capturing an audio signal in correlation with the captured video signal (column 7, lines 45-68, and column 9, lines 5-24).

Regarding *claim 36*, Hannon discloses the system discussed above in claim 1, and further teaches of a self-contained power source for powering the system (see Fig. 2, column 5, line 59-column 6, line 14).

Regarding *claim 37*, Hannon discloses the system discussed above in claim 36, and further teaches that the communications device is adapted to be used independently of the image capture device and the processor (column 5, line 59-column 6, line 14), and wherein the power supply is adapted for isolating the power to the communications device from the power to the image capture device and processor (column 5, line 59-column 6, line 14).

Regarding *claim 38*, Hannon discloses the system discussed above in claim 37, and further teaches of a power initiation device associated with the image capture device and the processor (column 5, line 59-column 6, line 2), wherein the power to the image capture device and the processor is off when the initiation device is not activated (column 5, line 59-column 6, line 2, and column 9, lines 5-24).

Art Unit: 2622

Regarding **claim 39**, Hannon discloses the system discussed above in claim 38, and further teaches that the power initiation device is user controlled (column 5, line 48-column 6, line 58, column 7, lines 1-68, and column 9, lines 5-24).

Regarding **claim 40**, Hannon discloses the system discussed above in claim 38, and further teaches of a trigger device for activating the power initiation device (see Fig. 2, column 5, lines 48-58, column 7, lines 1-11, and column 9, line 1-column 10, line 3).

Regarding **claim 41**, Hannon discloses the system discussed above in claim 40, and further teaches that the trigger device is a timer (column 6, line 66-column 7, line 2, and column 9, lines 5-24).

Regarding **claim 42**, Hannon discloses the system discussed above in claim 40, and further teaches that the trigger device is triggered by the presence of an image to be captured (column 5, lines 48-58, column 7, lines 1-11, and column 9, lines 5-24).

21. **Claims 1-3, 23, 24, 28, and 43-62** are rejected under 35 U.S.C. 102(b) as being anticipated by Collett *et al.* (U.S. Patent Number 5,517,683).

Regarding **claim 1**, Collett discloses a self-contained image processing system (see Figs. 1a, 1b, 7a, and 7b) for capturing a visual image and transmitting it to a remote receiving station (column 8, lines 1-34), with the system comprising an image capture device (micro-camera 126, column 8, lines 1-19), a processor for generating a data signal representing the image (printed circuit board 38, column 5, line 25-column 6, line 61, and column 8, lines 1-19), a communications device adapted for transmitting the data signal to the remote receiving station

Art Unit: 2622

(column 8, lines 1-34), and a wireless transmission system between the communications device and the compatible receiving station (column 4, lines 7-32, and column 8, lines 1-59).

Regarding *claim 2*, Collett discloses the system discussed above in claim 1, and further teaches of a memory for receiving and storing the data signal (column 7, lines 36-67), and wherein the communications device is adapted for recalling the stored data signal from memory (column 7, lines 36-column 8, line 19).

Regarding *claim 3*, Collett discloses the system discussed above in claim 2, and further teaches that the memory is a removable RAM (see Fig. 6, PCMCIA card, column 7, line 36-column 8, line 19) and wherein the system is adapted for selectively charging and discharging the memory (column 1, line 30-column 2, line 15, and column 4, lines 19-58).

Regarding *claim 23*, Collett discloses the system discussed above in claim 1, and further teaches of a data processor for creating a text data signal associated with the image data signal (column 3, lines 54-column 4, line 32, and column 8, lines 1-11).

Regarding *claim 24*, Collett discloses the system discussed above in claim 23, and further teaches of an input device for providing text data to the data processor (column 3, lines 54-column 4, line 32).

Regarding *claim 28*, Collett discloses the system discussed above in claim 24, and further teaches that the input device comprises a global positioning system (column 8, lines 1-11).

Regarding *claim 43*, Collett discloses a handheld self-contained cellular telephone and integrated image processing system (see abstract and Figs. 1a, 1b, 7a, and 7b) for both sending and receiving telephonic audio signals and for capturing a visual image and transmitting it to a remote receiving station (column 8, lines 1-25), the system comprising a housing (see Figs. 1a,

Art Unit: 2622

1b, 7a, and 7b), an image capture device comprising a electronic camera contained within the housing (column 8, lines 1-25), a display for displaying an image framed by the camera (display panel 14 and LCD screen 124, column 3, lines 54-57, column 8, lines 21-25), a processor (printed circuit board 38, seen in Figs. 1b-4) in the housing for generating an image data signal representing the image framed by the camera (video display control electronics, column 8, lines 20-25), a telephonic system in the housing for sending and receiving digitized audio signals and adapted for sending the image data signal (column 3, lines 54-column 4, line 32, and column 8, lines 1-25), alphanumeric input keys in the housing for permitting manually input digitized alphanumeric signals to be input to the processor (column 3, lines 54-column 4, line 32), the telephonic system being further adapted for sending the digitized alphanumeric signals (column 8, lines 1-11), a wireless communications device adapted for transmitting any of the digitized signals to a compatible remote receiving station (column 8, line 26-column 9, line 55), and a power supply in the housing for powering the system (column 4, lines 7-18, and column 5, lines 13-25).

Regarding *claim 44*, Collett discloses the system discussed above in claim 43, and further teaches of a display for framing the image to be captured by the image capture device and for displaying the image at the system whereby the operator can view and frame the image prior to capture (column 8, lines 1-25).

Regarding *claim 45*, Collett discloses the system discussed above in claim 43, and further teaches that the display is adapted for viewing alphanumeric messages input at the alphanumeric keys (column 8, lines 1-25).

Regarding *claim 46*, Collett discloses the system discussed above in claim 43, and further teaches that the communications system is adapted for receiving incoming alphanumeric messages from a remote station and wherein the display is adapted for viewing such incoming alphanumeric messages (column 8, lines 1-25).

Regarding *claim 47*, Collett discloses the system discussed above in claim 43, and further teaches that the communications system is adapted for receiving incoming image data signals and wherein the display is adapted for viewing such incoming image data signals (column 8, lines 1-25).

Regarding *claim 48*, Collett discloses the system discussed above in claim 43, and further teaches of a removable memory module adapted to be removably housed in the housing for storing captured image data signals (see Fig. 6, column 7, lines 36-67).

Regarding *claim 49*, Collett discloses the system discussed above in claim 43, and further teaches that the system is adapted for operating in any combination of three distinct functions, being an audio telephone, a transmitting system for transmitting captured image data signals via a cellular telephone, and for receiving incoming transmissions such as configuration signals or incoming image data signals (column 8, lines 1-25).

Regarding *claim 50*, Collett discloses the system discussed above in claim 49, and further teaches that the display is adapted for viewing incoming image data signals (column 8, lines 1-25).

Regarding *claim 51*, Collett discloses a handheld cellular telephone having an integrated electronic camera for both sending and receiving telephonic audio signals and for capturing a visual image (see abstract, Figs. 1a, 1b, 7a, and 7b, and column 8, lines 1-25), converting the



Art Unit: 2622

visual image to a digitized image data signal and transmitting digitized image data signal via a cellular telephone network, the cellular telephone comprising a housing (see Figs. 1a, 1b, 7a, and 7b), a cellular telephone in the housing, the cellular telephone further including a transmitter/receiver for transmitting and receiving audio telephone messages over a cellular network (column 3, lines 54-column 4, line 32, and column 8, lines 1-25), a keypad for entering manually input alphanumeric signals to be transmitted over the cellular telephone network (column 3, lines 54-column 4, line 32), and a display window for viewing the manually input alphanumeric signals (LCD screen 124, column 8, lines 21-25), an electronic camera in the housing (column 8, lines 1-25), the digitized camera adapted for visually framing a visual image to be captured and for capturing and digitizing the framed image in a format adapted for transmission over the cellular network via the cellular telephone (column 8, lines 1-25), an integrated power supply for powering both the cellular telephone and the camera (column 4, lines 7-18, and column 5, lines 13-25).

Regarding *claim 52*, Collett discloses the telephone discussed above in claim 51, and further teaches of a display window for viewing the alphanumeric signals within the display for framing the visual image (column 8, lines 1-25).

Regarding *claim 53*, Collett discloses the telephone discussed above in claim 51, and further teaches of a memory in the housing for storing the captured framed image (see Fig. 6, column 7, lines 36-67).

Regarding *claim 54*, Collett discloses the telephone discussed above in claim 53, and further teaches that the memory is selectively removable from the housing (see Fig. 6, column 7, lines 36-67).

Art Unit: 2622

Regarding *claim 55*, Collett discloses a combination of handheld cellular telephone and electronic camera (see Figs. 1a, 1b, 7a, and 7b, column 8, lines 1-25) comprising a housing (see Figs. 1a, 1b, 7a, and 7b), an electronic camera in the housing (column 8, lines 1-25), a display in the housing (LCD screen 124, column 8, lines 21-25), a processor for processing the image framed by the camera (printed circuit board 38, seen in Figs. 1b-4, via the video display control electronics, column 8, lines 20-25), a cellular telephone in the housing and adapted for accepting and digitizing audio signals to be transmitted and for converting received digitized audio signals into acoustic audio (column 3, lines 54-column 4, line 32), the cellular telephone further adapted for transmitting and receiving non-audio digital signals including digitized image signals (column 3, lines 54-column 4, line 32, and column 8, lines 1-25), alphanumeric input keys in the housing for permitting manually input alphanumeric signals to be input into the cellular telephone (column 3, lines 54-column 4, line 32), the manually input alphanumeric signals being presented in a display (column 8, lines 1-25), a power supply in the housing for powering the processor, the cellular telephone, the display and the camera (column 4, lines 7-18, and column 5, lines 13-25), a wireless transmitter/receiver in the housing for transmitting digital signals sent from and receiving digital signals sent to the cellular telephone (column 8, line 26-column 9, line 55).

Regarding *claim 56*, Collett discloses the combination discussed above in claim 55, and further teaches of a display for framing the image to be captured by the image capture device and for displaying the image at the system whereby the operator can view and frame the image prior to capture (column 8, lines 1-25).

Art Unit: 2622

Regarding *claim 57*, Collett discloses the combination discussed above in claim 55, and further teaches that the display is adapted for viewing alphanumeric messages input at the alphanumeric input keys (column 8, lines 1-25).

Regarding *claim 58*, Collett discloses the combination discussed above in claim 55, and further teaches that the telephone is adapted for receiving incoming alphanumeric messages from a remote station and wherein the display is adapted for viewing such incoming alphanumeric messages (column 8, lines 1-25).

Regarding *claim 59*, Collett discloses the combination discussed above in claim 55, and further teaches that the telephone is adapted for receiving incoming image data signals and wherein the display is adapted for viewing such incoming image data signals (column 8, lines 1-25).

Regarding *claim 60*, Collett discloses the combination discussed above in claim 55, and further teaches of a removable memory module adapted to be removably housed in the housing for storing captured image data signals (see Fig. 6, column 7, lines 36-67).

Regarding *claim 61*, Collett discloses the combination discussed above in claim 60, and further teaches of being adapted for operating in any combination of three distinct functions, being an audio telephone, a transmitting system for transmitting captured image data signals via a cellular telephone, and for receiving incoming transmissions such as configuration signals or incoming image data signals (column 8, lines 1-25).

Regarding *claim 62*, Collett discloses the combination discussed above in claim 60, and further teaches that the display is adapted for viewing incoming image data signals (column 8, lines 1-25).

***Claim Rejections - 35 USC § 103***

22. The following is a quotation of 35 U.S.C. 103(a) which forms the basis for all obviousness rejections set forth in this Office action:

(a) A patent may not be obtained though the invention is not identically disclosed or described as set forth in section 102 of this title, if the differences between the subject matter sought to be patented and the prior art are such that the subject matter as a whole would have been obvious at the time the invention was made to a person having ordinary skill in the art to which said subject matter pertains. Patentability shall not be negated by the manner in which the invention was made.

23. **Claims 13, 18, and 29** are rejected under 35 U.S.C. 103(a) as being unpatentable over Hassan *et al.* (U.S. Patent Number 5,550,646, cited in the Office action dated 9/27/04) in view of Ross (U.S. Patent Number 5,546,194, cited in the Office action dated 9/27/04).

Regarding **claim 13**, Hassan discloses the system discussed above in claim 1, but fails to expressly disclose if the image capture device is an analog video camera for generating a video signal.

Ross discloses a self-contained image processing system (see Fig. 1) for capturing a visual image and transmitting it to a remote receiving station, with the system comprising an image capture device (video camera 10, column 3, lines 4 through 5), a processor (control system 22 in Fig. 1, or CPU 44 in Fig. 2) for generating a data signal representing the image (column 3, lines 20 through 29, and column 3, line 63 through column 4, line 20), a communications device (Group III fax transmitter 20 in Fig. 1, and fax modem 50 in Fig. 2) adapted for transmitting the data signal to the remote receiving station (column 2, lines 15 through 29, wherein the remote receiving station is inherently included in the system), and a subprocessor (Group III formatter 18) for generating a Group-III facsimile compatible signal representing the data signal (column 3, lines 30 through 52). Continuing, Ross teaches that the image capture device is an analog video camera for generating a video signal (column 3, lines 4 through 9). Further Ross teaches

Art Unit: 2622

that the processor comprises a sync detector (sync separator 24, column 3, lines 53 through 62) and a video address generator (address multiplexer 43, column 4, lines 6 through 11) for synchronizing the digital signal with the analog signal for defining the beginning and end of the signal to define a still frame (column 3, lines 20 through 62), a random access memory (RAM 38) for receiving and storing the converted, synchronized signal frame-by-frame (column 4, lines 3 through 22), a processor routine for converting the signals stored in the memory to a protocol adapted for transmission (column 4, lines 22 through 36) to a remote, compatible protocol receiving station (inherently included), and a communications device (FAX modem 50) for transmitting the signal in the proper protocol to the compatible receiving station (column 5, lines 7 through 16).

Hassan & Ross are combinable because they are from the same field of endeavor, that being systems that transmit images from a camera to a destination via facsimile transmission. At the time of the invention, it would have been obvious to a person of ordinary skill in the art to include the analog video camera that transmits a video signal, which is taught by Ross, in the system of Hassan. The suggestion/motivation for doing so would have been that Hassan's system would become usable in more formats, as recognized by Ross in column 1, thereby increasing the system's desirability. Therefore, it would have been obvious to combine the teachings of Ross with the system of Hassan to obtain the invention as specified in claim 13.

Regarding *claim 18*, Hassan and Ross disclose the system discussed above in claim 13, and Hassan further teaches of an integral viewer for viewing the images stored in the memory (LCD display 215, column 4, lines 19 through 64).

Art Unit: 2622

Regarding *claim 29*, Hassan discloses the system discussed above in claim 2, but fails to expressly disclose if the image data signal is stored in a raw video format.

Ross discloses a self-contained image processing system (see Fig. 1) for capturing a visual image and transmitting it to a remote receiving station, with the system comprising an image capture device (video camera 10, column 3, lines 4 through 5), a processor (control system 22 in Fig. 1, or CPU 44 in Fig. 2) for generating a data signal representing the image (column 3, lines 20 through 29, and column 3, line 63 through column 4, line 20), a communications device (Group III fax transmitter 20 in Fig. 1, and fax modem 50 in Fig. 2) adapted for transmitting the data signal to the remote receiving station (column 2, lines 15 through 29, wherein the remote receiving station is inherently included in the system), and a subprocessor (Group III formatter 18) for generating a Group-III facsimile compatible signal representing the data signal (column 3, lines 30 through 52). Continuing, Ross teaches of a memory for receiving and storing the data signal (RAM 38, column 3, line 65 through column 4, line 11), and that the image data signal is stored in a raw video format (column 3, line 63 through column 4, line 51).

Hassan & Ross are combinable because they are from the same field of endeavor, that being systems that transmit images from a camera to a destination via facsimile transmission. At the time of the invention, it would have been obvious to a person of ordinary skill in the art to include the analog video camera that transmits a video signal, which is taught by Ross, in the system of Hassan. The suggestion/motivation for doing so would have been that Hassan's system would become usable in more formats, as recognized by Ross in column 1, thereby increasing the system's desirability. Therefore, it would have been obvious to combine the teachings of Ross with the system of Hassan to obtain the invention as specified in claim 29.

Art Unit: 2622

24. **Claims 19 and 20** are rejected under 35 U.S.C. 103(a) as being unpatentable over Hassan *et al.* (U.S. Patent Number 5,550,646, cited in the Office action dated 9/27/04) in view of Ross (U.S. Patent Number 5,546,194, cited in the Office action dated 9/27/04), and further in view of Collett *et al.* (U.S. Patent Number 5,517,683).

Regarding **claims 19 and 20**, Hassan and Ross disclose the system discussed above in claim 13, but fail to expressly disclose if the memory is a removable memory medium which may be selectively removed from the system, with the removable memory medium comprising a PCMCIA card memory.

Collett discloses a self-contained image processing system (see Figs. 1a, 1b, 7a, and 7b) for capturing a visual image and transmitting it to a remote receiving station (column 8, lines 1-34), with the system comprising an image capture device (micro-camera 126, column 8, lines 1-19), a processor for generating a data signal representing the image (printed circuit board 38, column 5, line 25-column 6, line 61, and column 8, lines 1-19), a communications device adapted for transmitting the data signal to the remote receiving station (column 8, lines 1-34), and a wireless transmission system between the communications device and the compatible receiving station (column 4, lines 7-32, and column 8, lines 1-59). Continuing, Collett teaches of a memory for receiving and storing the data signal (column 7, lines 36-67), and wherein the communications device is adapted for recalling the stored data signal from memory (column 7, lines 36-column 8, line 19). Further, Collett teaches that the memory is a removable memory medium which may be selectively removed from the system (see Fig. 6, PCMCIA card, column 7, line 36-column 8, line 19), with the removable memory medium comprises a PCMCIA card memory (column 1, line 30-column 2, line 15, and column 4, lines 19-58).

Art Unit: 2622

Hassan, Ross & Collett are combinable because they are each from the same field of endeavor, that being systems that transmit images from a camera to a destination. At the time of the invention, it would have been obvious to a person of ordinary skill in the art to include the removable PCMCIA card memory, which is taught by Collett, in the system of Hassan and Ross. The suggestion/motivation for doing so would have been that the system of Hassan and Ross would become more user-friendly, since allowing a user to load data on a portable, removable memory would aid the user's options of data storage, as recognized in column 7 by Collett. Therefore, it would have been obvious to combine the teachings of Collett with the system of Hassan and Ross to obtain the invention as specified in claims 19 and 20.

### *Conclusion*

25. Applicant's amendment necessitated the new ground(s) of rejection presented in this Office action. Accordingly, **THIS ACTION IS MADE FINAL**. See MPEP § 706.07(a). Applicant is reminded of the extension of time policy as set forth in 37 CFR 1.136(a).

A shortened statutory period for reply to this final action is set to expire **THREE MONTHS** from the mailing date of this action. In the event a first reply is filed within **TWO MONTHS** of the mailing date of this final action and the advisory action is not mailed until after the end of the **THREE-MONTH** shortened statutory period, then the shortened statutory period will expire on the date the advisory action is mailed, and any extension fee pursuant to 37 CFR 1.136(a) will be calculated from the mailing date of the advisory action. In no event, however, will the statutory period for reply expire later than **SIX MONTHS** from the date of this final action.



Art Unit: 2622

26. Any inquiry concerning this communication or earlier communications from the examiner should be directed to Joe Pokrzywa whose telephone number is (571) 272-7410. The examiner can normally be reached on Monday-Friday, 9:00-5:00.

If attempts to reach the examiner by telephone are unsuccessful, the examiner's supervisor, Edward L. Coles can be reached on (571) 272-7402. The fax phone number for the organization where this application or proceeding is assigned is 703-872-9306.

Information regarding the status of an application may be obtained from the Patent Application Information Retrieval (PAIR) system. Status information for published applications may be obtained from either Private PAIR or Public PAIR. Status information for unpublished applications is available through Private PAIR only. For more information about the PAIR system, see <http://pair-direct.uspto.gov>. Should you have questions on access to the Private PAIR system, contact the Electronic Business Center (EBC) at 866-217-9197 (toll-free).

Joseph R. Pokrzywa  
Primary Examiner  
Art Unit 2622



jrj

2622 JW



PTO/SB/21 (09-04)  
Approved for use through 07/31/2006. OMB 0651-0031  
U.S. Patent and Trademark Office, U.S. DEPARTMENT OF COMMERCE

Under the Paperwork Reduction Act of 1995, no persons are required to respond to a collection of information unless it displays a valid OMB control number.

|  |                        |                    |
|--|------------------------|--------------------|
| <b>TRANSMITTAL FORM</b><br><small>(to be used for all correspondence after initial filing)</small> | Application Number     | 10/336,470         |
|  | Filing Date            | January 3, 2003    |
|  | First Named Inventor   | David A. Monroe    |
|  | Art Unit               | 2622               |
|  | Examiner Name          | Joseph R. Pokrzywa |
| Total Number of Pages in This Submission   | Attorney Docket Number | 121817.0002.042    |

| ENCLOSURES (Check all that apply)   |   |  |
|---|---|--|
| <input type="checkbox"/> Fee Transmittal Form<br><input type="checkbox"/> Fee Attached<br><input checked="" type="checkbox"/> Amendment/Reply<br><input type="checkbox"/> After Final<br><input type="checkbox"/> Affidavits/declaration(s)<br><input type="checkbox"/> Extension of Time Request<br><input type="checkbox"/> Express Abandonment Request<br><input type="checkbox"/> Information Disclosure Statement<br><input type="checkbox"/> Certified Copy of Priority Document(s)<br><input type="checkbox"/> Reply to Missing Parts/ Incomplete Application<br><input type="checkbox"/> Reply to Missing Parts under 37 CFR 1.52 or 1.53 | <input checked="" type="checkbox"/> Drawing(s)<br><input type="checkbox"/> Licensing-related Papers<br><input type="checkbox"/> Petition<br><input type="checkbox"/> Petition to Convert to a Provisional Application<br><input type="checkbox"/> Power of Attorney, Revocation<br><input type="checkbox"/> Change of Correspondence Address<br><input type="checkbox"/> Terminal Disclaimer<br><input type="checkbox"/> Request for Refund<br><input type="checkbox"/> CD, Number of CD(s) _____<br><input type="checkbox"/> Landscape Table on CD | <input type="checkbox"/> After Allowance Communication to TC<br><input type="checkbox"/> Appeal Communication to Board of Appeals and Interferences<br><input type="checkbox"/> Appeal Communication to TC (Appeal Notice, Brief, Reply Brief)<br><input type="checkbox"/> Proprietary Information<br><input type="checkbox"/> Status Letter<br><input checked="" type="checkbox"/> Other Enclosure(s) (please identify below):<br>1. Postcard |
| Remarks   |   |  |

| SIGNATURE OF APPLICANT, ATTORNEY, OR AGENT |                 |          |        |
|--|-----------------|----------|--------|
| Firm Name                                  |                 |          |        |
| Signature                                  |                 |          |        |
| Printed name                               | Raffi Gostanian |          |        |
| Date                                       | 5/17/05         | Reg. No. | 42,595 |

| CERTIFICATE OF TRANSMISSION/MAILING   |                 |      |         |
|---|-----------------|------|---------|
| I hereby certify that this correspondence is being facsimile transmitted to the USPTO or deposited with the United States Postal Service with sufficient postage as first class mail in an envelope addressed to: Commissioner for Patents, P.O. Box 1450, Alexandria, VA 22313-1450 on the date shown below: |                 |      |         |
| Signature   |                 |      |         |
| Typed or printed name   | Raffi Gostanian | Date | 5/17/05 |

This collection of information is required by 37 CFR 1.5. The information is required to obtain or retain a benefit by the public which is to file (and by the USPTO to process) an application. Confidentiality is governed by 35 U.S.C. 122 and 37 CFR 1.11 and 1.14. This collection is estimated to 2 hours to complete, including gathering, preparing, and submitting the completed application form to the USPTO. Time will vary depending upon the individual case. Any comments on the amount of time you require to complete this form and/or suggestions for reducing this burden, should be sent to the Chief Information Officer, U.S. Patent and Trademark Office, U.S. Department of Commerce, P.O. Box 1450, Alexandria, VA 22313-1450. DO NOT SEND FEES OR COMPLETED FORMS TO THIS ADDRESS. SEND TO: Commissioner for Patents, P.O. Box 1450, Alexandria, VA 22313-1450.

If you need assistance in completing the form, call 1-800-PTO-9199 and select option 2.



### Amendments to the Specification

Please amend the specification as follows:

Please amend paragraph [0044] as follows:

**[0044]** Fig. 7A and 7B are perspective drawings of a hand held device for capturing, storing and transmitting an image in accordance with the invention ~~(new drawings to replace Frassintino design.~~

Please amend paragraph [0045] as follows:

**[0045]** Figs. 8A-8L ~~(Formerly Fig. 12)~~ comprises a schematic diagram for an exemplary embodiment of the circuit for supporting the subject invention.

Please amend paragraph [0052] as follows:

**[0052]** The configuration of Fig. 3 incorporates all of the features of Figs. 1 and 2, and additionally, includes an interim data compression and decompression scheme to permit increased utilization of the memory or storage medium 46. As shown in Fig. 3, an interim format compressor 56 is inserted between the gray scale bit map 16 and the memory device 46. This permits compression and reduction of the data required to store the image, effectively increasing the capacity of the storage device. It is an objective of the storage device to preserve the gray scale quality of the image for viewing at the location of capture. An interim format decompression device 58 is inserted between the output of the memory device 46 and the rest of the system, whether the optional viewer 48 is utilized, or the output is entered directly into the half-tone converter 18. The interim compression/decompression scheme is particularly useful when all of the image data is to be permanently archived, or when limited capacity portable media are used, such as, by way of example, floppy disks or a portable PCMCIA card. It will be noted that the remainder of the system shown in Fig. 3 is identical to the system shown and described in Fig. 2.

**Amendments to the Drawings**

Please amend the drawings as follows:

Fig. 4 was amended as follows: Original reference numeral 66 indicating a PC MODEM PROTOCOL was changed to reference numeral 68.

Fig. 5 was amended as follows: Original reference numeral 81 indicating a DATA MUX was changed to reference numeral 81a, and original reference numeral 83 indicating a connection between a SYNC DETECTOR 78 and a R/W CTRL 84 was changed to reference numeral 83a.

Replacement sheets for Figs. 4 and 5 are enclosed herein.

REMARKS

This supplementary amendment corrects certain grammatical errors in the specification as well as reference numeral errors in various figures. No new matter has been added.

Respectfully submitted,

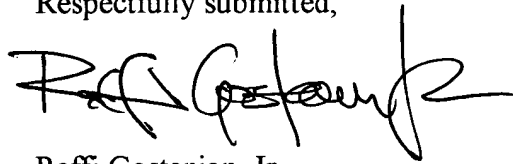

Raffi Gostanian, Jr.  
Registered Patent Agent  
Reg. No. 42,595  
(972) 849-1310

5/17/05  
Date

Please send all correspondences to:

Robert C. Curfiss  
P.O. Box 903  
Humble, Texas 77347



Replacement Sheet

FIG. 4

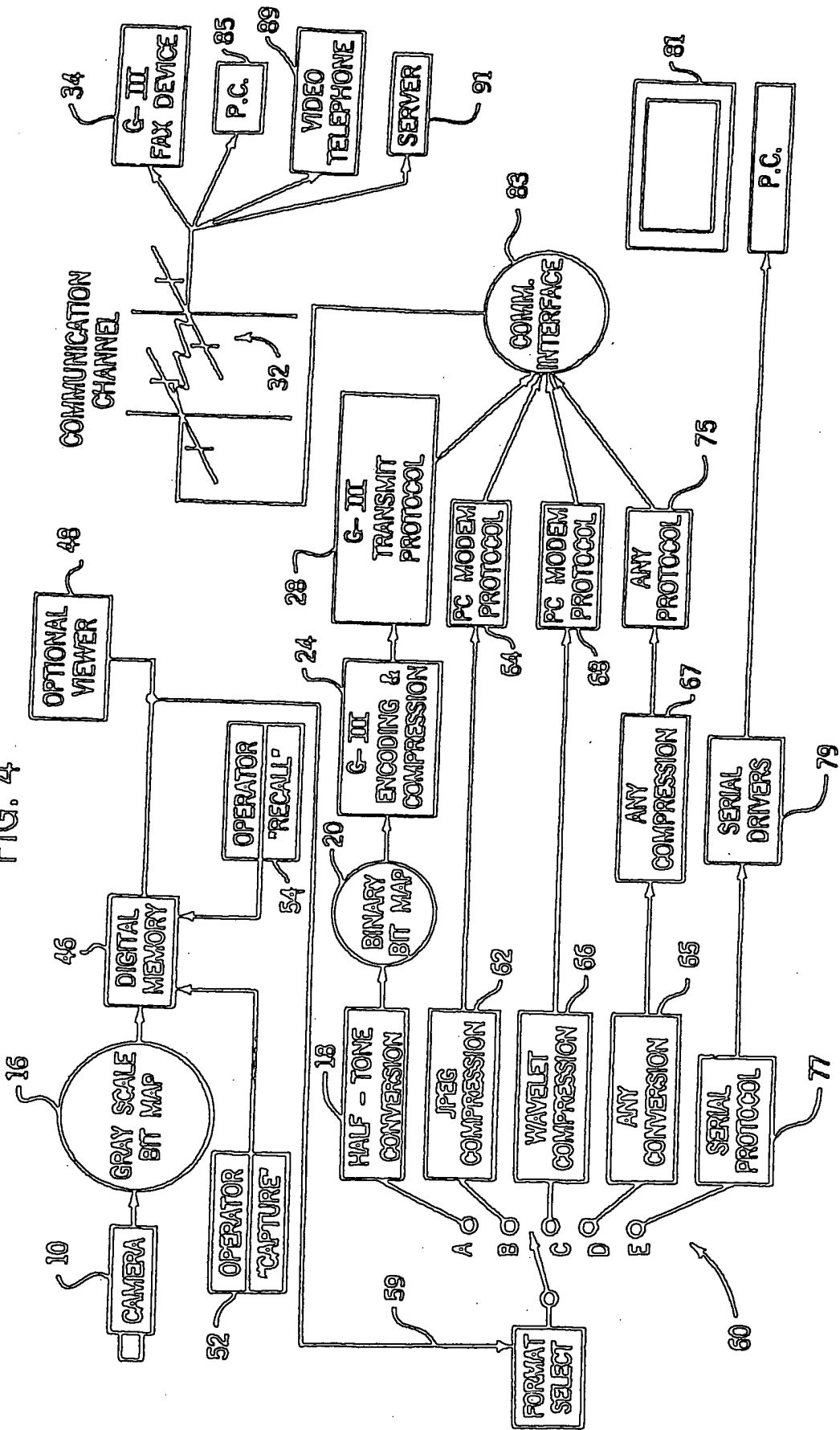







## Amendments to the Specification

Please amend the specification as follows:

Please amend paragraph [0051] as follows:

[0051] The embodiment of Fig. 2 is similar to Fig. 1, but incorporates a memory and optional operator viewer system. The image is captured by the camera 10 and conditioned by the gray scale bit map 16, as in Fig. 1. In this embodiment, the output 44 of the bit map 16 is input into a standard digital memory device 46 for later recall. This configuration is particularly well suited for applications where near real time transmission of the image either is not required or is not desirable. It will be noted that with the exception of the insertion of the memory device 46 and the optional viewer device 48, the capture and transmission system of Fig. 2 is identical to that shown and described in Fig. 1. Once the image is captured by the camera 10 and is presented at 44 to the memory device 46, it is stored for later recall and transmission. The specific type of memory device is optional and may include, for example, an SRAM device, a DRAM, Flash RAM, hard drive, floppy disk, PCMCIA format removable memory (see, for example, the PCMCIA card [50] 72 in Fig. 7A), writeable optical media or other storage device. The memory may selectively capture images, as indicated by the operator interface/capture interface 52, or may be programmed to selectively capture periodic images or all images. In the embodiment shown in Fig. 2, an optional viewer device 48 is provided. This permits the operator to recall and view all or selective images before transmission, as indicated by the operator interface/recall interface 54. This permits the operator to review all images retained in the memory 46 and transmit selective images, as desired, to the Group-III transmission system. The remainder of the system of Fig. 2 operates in the same manner as the configuration shown and described in Fig. 1.

Please amend paragraph [0054] as follows:

[0054] An exemplary circuit supporting the configurations of Figs. 1-4 is shown in Fig. 5. With specific reference to Fig. 5, an analog camera is indicated by the "video

in” signal at 70. Typically, the video signal is a composite video/sync signal. The diagram shows all of the signal processing necessary to sync up to an NTSC signal 70 coming out of the analog camera and processed for introduction into an integral RAM memory 71 and/or a portable RAM memory via interface 73. An analog to digital (A/D) converter 74 converts the video portion of the analog signal from the camera and produces the digital signal for output at line 76. The digital output data on path 76 is introduced into a data multiplexer circuit 81a and into the RAM memory unit(s) 71, 72. In the exemplary embodiment, the portable RAM memory 72 is an image card such as, by way of example, a PCMCIA SRAM card or a PCMCIA Flash RAM card. However, it will be readily understood that any suitable RAM memory configuration can be used within the teachings of the invention. It is desirable to store compressed rather than raw data in card 72 because of space and transmission speed factors.

Please amend paragraph [0055] as follows:

[0055] As the signal at 70 is introduced into the circuit, the sync detector 78 strips the sync signal portion off of the video signal. The sync signal drives the video address generator 80 for providing a signal used to generate an address signal at the address multiplexer circuit 82 for synchronizing the scanned in video signal with the locations in RAM to define each frame to be captured. The read/write control 84 controls the coordination of the sync signal 93 with the video signal to define a full frame. Basically, when the camera is activated either by the operator or by automation, the system processor 86 detects the initiation of the camera and capture sequence and sends a signal via line 88 to the read/write control 84. The read/write control then monitors the incoming video signal 83a to find the horizontal and vertical sync pulse to identify the beginning of a frame. The read/write control then initiates writing to memory at the RAM devices to initiate capture of the frame. The read/write control continues to “write” to memory until the appropriate sync signal is received, indicating the end of the frame. At this point a single frame is captured in RAM 71 and/or on the portable medium RAM 72.

Please amend paragraph [0066] as follows:

[0066] In order to send a facsimile transmission over a typical Group-III Facsimile system, the multiplexer 82 is switched to the processor 86 such that the RAM address is generated by the processor 82 instead of the video address generator signal. In the facsimile transmitting mode, the processor accesses the RAM and manipulates the data representing each frame image. For example, the processor will perform the gray scale to half tone conversions described in connection with Figs. 1-4 to prepare the signal for facsimile transmission. The processor can also perform image compression and output the image as a gray scale. In the facsimile transmission mode, once the half tone conversion is completed, the processor executes a code for performing a bi-level compression of the data and the signal representing the frame data is output over line 90, through the multiplexer 81a and over the processor bus 87 to the processor 86, then to modem 104 for transmission. Other memory and processor configurations could be used without departing from the scope and spirit of the invention, as will be recognized by those skilled in the art.

**Amendments to the Drawings**

Please amend Fig. 5 as follows: Please change reference numeral 81 to reference numeral 81a.

A letter to the Office Draftsman and the amendments to Fig. 5 were previously presented. This letter and the amended drawing are attached to this paper.

**Amendments to the Claims:**

This listing of claims will replace all prior versions, and listings, of claims in the application:

**Listing of Claims:**

1. (Original) A self-contained image processing system for capturing a visual image and transmitting it to a remote receiving station, the image processing system comprising:
  - a. an image capture device;
  - b. a processor for generating a data signal representing the image;
  - c. a communications device adapted for transmitting the data signal to the remote receiving station;
  - d. a wireless transmission system between the communications device and the compatible receiving station.
  
2. (Original) The image processing system of claim 1, further including a memory for receiving and storing the data signal, and wherein the communications device is adapted for recalling the stored data signal from memory.
  
3. (Currently amended) The image processing system of claim [1] 2, wherein said memory is a removable random access medium and wherein the system is adapted for selectively charging and discharging the memory.
  
4. (Original) The image processing system of claim 1, wherein the image capture device is an analog camera for generating an analog image signal and there is further included an analog to digital converter for converting the analog image signal to a digital signal.
  
5. (Cancelled)
  
6. (Cancelled)

7. (Original) The image processing system of claim 1, wherein there is further included an integrated wireless telephone associated with the communications device.

8. (Original) The image processing system of claim 1, further comprising a housing for housing all of the elements of the system in an integrated body.

9. (Original) The image processing system of claim 1, wherein said image capture device is a digital camera.

10. (Cancelled)

11. (Cancelled)

12. (Original) The image processing system of claim 1, wherein the processor is adapted for generating a signal in any of a plurality of selected protocols and wherein the communications device is adapted for transmitting the signal in the proper protocol to a remote, compatible receiving station.

13. (Original) The image processing system of claim 1, wherein:

a. the image capture device is an analog video camera for generating a video signal;

b. the processor further comprises:

i. an analog to digital converter;

ii. a sync detector and a video address generator for synchronizing the digital signal with the analog signal for defining the beginning and end of the signal to define a still frame;

iii. a random access memory for receiving and storing the converted, synchronized signal frame-by-frame;

iv. a processor routine for converting the signals stored in the memory to a protocol adapted for transmission to a remote, compatible protocol receiving station;

c. a communications device for transmitting the signal in the proper protocol to the compatible receiving station.

14. (Cancelled)

15. (Cancelled)

16. (Cancelled)

17. (Cancelled)

18. (Original) The image processing system of claim 13, further including an integral view for viewing the images stored in the memory.

19. (Original) The image processing system of claim 13, wherein the memory is a removable memory medium which may be selectively removed from the system.

20. (Original) The image processing system of claim 19, wherein the removable memory medium comprises a PCMCIA card memory.

21. (Cancelled)

22. (Original) The image processing system of claim 1, further comprising an audio signal capture device adapted for capturing an audio signal in correlation with the captured video signal.

23. (Original) The image processing system of claim 1, further comprising a data processor for creating a text data signal associated with said image data signal.

24. (Original) The image processing system of claim 23, further including an input device for providing text data to the data processor.

25. (Original) The image processing system of claim 24, wherein the input device is user controlled.

26. (Original) The image processing system of claim 25, wherein said user controlled input device is an integral keyboard.

27. (Original) The image processing system of claim 24, said input device comprising a real time clock.

28. (Original) The image processing system of claim 24, said input device comprising a global positioning system.

29. (Original) The image processing system of claim 24, wherein said image data signal is stored in a raw video format.

30. (Original) The image processing system of claim 2, wherein the image data signal is stored in a compressed format.

31. (Cancelled)

32. (Cancelled)

33. (Cancelled)

34. (Cancelled)

35. (Original) The image processing system of claim 1, wherein the remote receiving station is a digital device and the image data is digital.

36. (Original) The image processing system of claim 1, further comprising a self-contained power source for powering the system.



37. (Original) The image processing system of claim 36, wherein said communications device is adapted to be used independently of the image capture device and the processor, and wherein the power supply is adapted for isolating the power to the communications device from the power to the image capture device and processor.

38. (Original) The image processing system of claim 37, further including a power initiation device associated with the image capture device and the processor wherein the power to the image capture device and the processor is off when the initiation device is not activated.

39. (Original) The image processing system of claim 38, wherein the power initiation device is user controlled.

40. (Original) The image processing system of claim 38, further including a trigger device for activating the power initiation device.

41. (Original) The image processing system of claim 40, wherein the trigger device is a timer.

42. (Original) The image processing system of claim 40, wherein the trigger device is triggered by the presence of an image to be captured.

43. (Previously presented) A handheld self-contained cellular telephone and integrated image processing system for both sending and receiving telephonic audio signals and for capturing a visual image and transmitting it to a remote receiving station, the system comprising:

- a. A housing;
- b. An image capture device comprising a electronic camera contained within the housing;
- c. A display for displaying an image framed by the camera;

- d. A processor in the housing for generating an image data signal representing the image framed by the camera;
- e. A telephonic system in the housing for sending and receiving digitized audio signals and adapted for sending the image data signal;
- f. Alphanumeric input keys in the housing for permitting manually input digitized alphanumeric signals to be input to the processor, the telephonic system being further adapted for sending the digitized alphanumeric signals;
- g. A wireless communications device adapted for transmitting any of the digitized signals to a compatible remote receiving station; and
- h. A power supply in the housing for powering the system.

44. (Previously presented) The self-contained image processing system of Claim 43, further comprising a display for framing the image to be captured by the image capture device and for displaying the image at the system whereby the operator can view and frame the image prior to capture.

45. (Previously presented) The self-contained image processing system of Claim 43, wherein the display is adapted for viewing alphanumeric messages input at the alphanumeric keys.

46. (Previously presented) The self-contained image processing system of Claim 43, wherein the communications system is adapted for receiving incoming alphanumeric messages from a remote station and wherein the display is adapted for viewing such incoming alpha numeric messages.

47. (Previously presented) The self-contained image processing system of Claim 43, wherein the communications system is adapted for receiving incoming image data signals and wherein the display is adapted for viewing such incoming image data signals.

48. (Previously presented) The self-contained image processing system of Claim 43, further comprising a removable memory module adapted to be removably housed in the housing for storing captured image data signals.

49. (Previously presented) The self-contained image processing system of Claim 43, wherein the system is adapted for operating in any combination of three distinct functions: (1) an audio telephone, (2) a transmitting system for transmitting captured image data signals via a cellular telephone, and (3) for receiving incoming transmissions such as configuration signals or incoming image data signals.

50. (Previously presented) The self-contained image processing system of Claim 49, wherein the display is adapted for viewing incoming image data signals.

51. (Previously presented) A handheld cellular telephone having an integrated electronic camera for both sending and receiving telephonic audio signals and for capturing a visual image, converting the visual image to a digitized image data signal and transmitting digitized image data signal via a cellular telephone network, the cellular telephone comprising:

- a. A housing;
- b. A cellular telephone in the housing, the cellular telephone further including a transmitter/receiver for transmitting and receiving audio telephone messages over a cellular network, a keypad for entering manually input alphanumeric signals to be transmitted over the cellular telephone network, and a display window for viewing the manually input alphanumeric signals;
- c. An electronic camera in the housing, the digitized camera adapted for visually framing a visual image to be captured and for capturing and digitizing the framed image in a format adapted for transmission over the cellular network via the cellular telephone;
- d. An integrated power supply for powering both the cellular telephone and the camera.

52. (Previously presented) The cellular telephone of Claim 51, wherein the display window for viewing the alphanumeric signals is within the display for framing the visual image.

53. (Previously presented) The cellular telephone of Claim 51, further including a memory in the housing for storing the captured framed image.

54. (Previously presented) The cellular telephone of Claim 53, wherein the memory is selectively removable from the housing.

55. (Previously presented) A combination of handheld cellular telephone and electronic camera comprising:

- a. A housing;
- b. A electronic camera in the housing;
- c. A display in the housing;
- d. A processor for processing the image framed by the camera;
- e. A cellular telephone in the housing and adapted for accepting and digitizing audio signals to be transmitted and for converting received digitized audio signals into acoustic audio, the cellular telephone further adapted for transmitting and receiving non-audio digital signals including digitized image signals;
- f. Alphanumeric input keys in the housing for permitting manually input alphanumeric signals to be input into the cellular telephone, the manually input alphanumeric signals being presented in a display;
- g. A power supply in the housing for powering the processor, the cellular telephone, the display and the camera;
- h. A wireless transmitter/receiver in the housing for transmitting digital signals sent from and receiving digital signals sent to the cellular telephone.

56. (Previously presented) The combination of Claim 55, further comprising a display for framing the image to be captured by the image capture device and for viewing the image at the system whereby the operator can view and frame the image prior to capture.

57. (Previously presented) The combination of Claim 55, wherein the display is adapted for viewing alphanumeric messages input at the alphanumeric input keys.

58. (Previously presented) The combination of Claim 55, wherein the cellular telephone is adapted for receiving incoming alphanumeric messages from a remote station and wherein the display is adapted for viewing such incoming alphanumeric messages.

59. (Previously presented) The combination of Claim 55, wherein the cellular telephone is adapted for receiving incoming image data signals and wherein the display is adapted for viewing such incoming image data signals.

60. (Previously presented) The combination of Claim 55, further comprising a removable memory module adapted to be removably housed in the housing for storing captured image data signals.

61. (Previously presented) The combination of Claim 60, further adapted for operating in any combination of three distinct functions: (1) an audio telephone, (2) a transmitting system for transmitting captured image data signals via a cellular telephone, and (3) for receiving incoming transmissions such as incoming image data signals.

62. (Previously presented) The combination of Claim 60, wherein the display is adapted for viewing incoming image data signals.

## REMARKS

The applicant appreciates the thoroughness applied by the Examiner in the examination of the application with respect to the Office Action mailed on 9/27/2004. After a careful review of the Examiner's comments, and as previously presented, Applicant has canceled claims 5, 6, 10, 11, 14-17, 21, 31-34 and has added claims 43-62, including independent claims 43, 51 and 55.

Per the Notice Of Non-Compliant Amendment mailed on 3/31/2005, Applicant has submitted a complete listing of claims in ascending numerical order, with the proper status identifiers.

Applicant has amended the errors in the specification as noted by the Examiner. It is respectfully submitted that no new matter has been added in these corrections.

The amendments to the drawings have been made in accordance with the Examiner's recommendations in a separate document previously filed with the Office Draftsman and previously presented in an amendment filed on January 3, 2005.

The previous amendment filed on January 3, 2005, indicated the following amendments to the specification should be made:

“Delete the reference to Fig. 7A and 7B

Paragraph 0051, line 361, change “PCMCIA card 50” to --PCMCIA card 72--.

Paragraph 0054, line 427, change “81” to --81a--.

Paragraph 0055, line 443, change “83” to --83a--.

Paragraph 0066, line 552, change “81” to --81a--.”

Applicant wishes to strike these amendments due to, for example, incorrect line numbers being cited, as well as an unintended statement to delete “the reference to Fig. 7A and 7B.” As such, Applicant has presented a correct listing of amendments to be made beginning on page 5 of this paper which include the entire paragraph in question as well as appropriate markings.

In view of the amendments to the claims, and as previously presented, the specific objection regarding informalities in Claim 5 is rendered moot, this claim having been canceled.

As previously presented, Claim 3 has been amended in accordance with the requirements of the Examiner.

As previously submitted, Applicant has filed an affidavit under 37 CFR 1.131, establishing an invention date at least earlier than March 23, 1993, more than one year before the filing date of the earliest patent relied upon by the Examiner. The affidavit and exhibits attached thereto clearly establish conception and reduction to practice and confirm due diligence between the conception date and the effective filing date of this application. For this reason, applicant submits that none references cited by the Examiner can be used as prior art in the subject application.

Moreover, as stated in the affidavit, none of these references combine a handheld system with the circuitry to support it, which as indicated in the affidavit, was a years long effort. It is respectfully submitted that the claims, as now pending are allowable in view of the invention date established by applicant and such action is requested.

In any event, applicant has discussed the various rejections made by the Examiner for sake of completion of the record.

Based on the affidavit and the arguments made herein it is respectfully submitted that this application is now in condition for allowance and such action is respectfully solicited.

## Claim Rejections

### Amended Claims Summary

Claims 1, 2, 4-12, 21, 23-27 and 30-36 have been rejected as anticipated by the Hassan et al '646 patent, under 35 U.S.C. §102(b), and anticipated by the Westberger '600 patent under 35 U.S.C §102(e), and anticipated by the Parulski et al '159 patent under 35 U.S.C. §102(e). Since this art is not relevant in view of the 131 Affidavit, this rejection should be withdrawn. However, the Examiner's arguments have been carefully considered in forming the new claims, in particular the new independent claims 43, 52 and 56, as well as original claim 1. The '646 patent, '600 patent and '159 patent will be reviewed with respect to the currently pending claims for sake of completeness of record.

### The Hassan et al '646 Patent

The Examiner has stated the '646 patent "discloses a self-contained image processing system...for capturing a visual image and transmitting it to a remote receiving station...a processor...a communications device...adapted for transmitting the data signal to the remote receiving station and a wireless transmission system between the communications device and the compatible receiving station."

With all due respect, while '646 patent mentions a cellular telephone at Column 2, line 5 and again at Column 2, line 53 and once again at Column 3, line 13, there is never any discussion as to how this may be accomplished. All of the embodiments shown and described in the '646 patent require hard wiring to a land line, as indicated by the RJ-11 jack 130 as shown in Figs. 1 and 2. There is not any discussion as to how the signal may need to be conditioned for transmission over a wireless system. For this reason, it is believed that the '646 patent is not a sound reference for rejection of original Claim 1 under 35 U.S.C. §102(b). In viewing the application for the '646 patent at the time it was filed, the reference to cellular telephone transmission can only be considered to be wishful thinking on the part of Hassan et al. However, in as much as Claim 1 has been substantially amended, applicant respectfully submits that the '646 patent cannot be applied as an anticipatory reference without pursuing the argument relative to wireless interconnectivity.

A clear reading of the '646 patent shows that it is directed to an imaging system adapted for converting an analog camera captured image to a fax data signal for transmission via a fax modem over a wired telephone line. While the '646 patent may suggest other uses,



it does not suggest how such uses may be implemented. Without the application of hindsight the '646 patent cannot be shown to read on anything other than a system utilizing an analog camera to create an image which may be converted to a Group-III fax for transmission over a typical fax modem and land line telephone to a remote recipient Group-III fax machine.

*The Wertsberger '600 Patent*

The Examiner has stated that the Wertsberger '600 patent "discloses a self-contained image processing system...for capturing a visual image and transmitting it to a remote receiving station...with the system comprising an image capture device...a processor...for generating a data signal for representing the image...a communications device...adapted for transmitting the data signal to the remote receiving station...and a wireless transmission system...between the communications device and the compatible receiving station."

Applicant does not disagree generally with this interpretation of the '600 patent. However, applicant would like to note, for the record, that only mention of wireless interconnectivity is at Column 5, lines 1-6, wherein it is stated:

"The Fax Modem Circuitry [13] is connected to Telephone Interface Circuitry [15] that allows the Fax Camera to connect to a public switched telephone network, or a cellular telephone communication link. Additionally, cellular telephone circuitry [70] may be built into the fax camera to provide self contained communications capability."

It is respectfully submitted that this reference to cellular technology does not disclose a system that is adapted for generating a data signal in an integrated unit for transmission over a wireless network. In order for the system to work as shown and described, it must be hardwired to something. There simply is not disclosed any wireless gateway.

In essence, the '600 patent discloses a camera with a digital convertor for generating a Group-III fax for transmission over a standard fax modem and which is hardwired to a telephone interface circuit (see, in particular, Fig. 1).

*Parulski et al '159 Patent*

The Examiner has stated that the Parulski '159 patent discloses "a self-contained image processing system...for capturing a visual image and transmitting it to a remote receiving station...with the system comprising an image capture device...a processor for generating a data signal representing the image...a communications device...adapted for

transmitting the data signal to the remote receiving communications device and the compatible receiving station.”

The ‘159 patent discloses an electronic camera system for selectively transmitting electronic image data to a plurality of remote base units. The camera module is detachably coupled to a computer having a display screen and a data entry device. Basically, this patent discloses a mechanism for connecting a camera to a computer with a display screen. The image data is then loaded into the computer and a transmitter associated with the computer is utilized to transmit the data to remote locations. There is a so-called camera/telephone embodiment shown in Fig. 7. As stated in the ‘159 patent, at Column 4, lines 26-53:

“A second embodiment of the invention is illustrated, in FIGS. 7 and 8. In this embodiment, a cellular telephone is provided with the components of an electronic image camera to form a combined telephone/camera unit 48. The top of the combined unit 48 includes a lens 50, a flip-up flash unit 52, and an antenna 54. The front face of the combined unit 48 is provided with a liquid crystal display screen 56 and a telephone keypad 58, both of which are coupled to an internal bus 60 along with a control processing unit 62, memory unit 64, and cellular transceiver 66 as shown in FIG. 9. The internal bus 60 is also connected to a camera module 68, which includes the same basic components as illustrated in FIG. 4, with the exception that the output from the image signal processor is supplied directly to the internal bus 60 instead of a connector.

In operation, as illustrated in greater detail by the flow diagram illustrated in FIG. 10, the user takes a picture by flipping up the flash unit 52 and pressing an image capture switch (not shown). Alternatively, a key (for example the # key) on the keypad 58 can be utilized as the image capture switch in an image capture mode of operation. The digitized picture data generated by the camera module 68 is stored in the memory unit 64 and displayed on the display screen 56. To transmit the image, the user dials the telephone number of a desired fax machine that is to receive the image using the keypad 58. The number is transmitted to the fax machine via the cellular transceiver 66.”

It should be noted that the ‘159 patent does not disclose, nor does it suggest the use of a combined camera and cellular telephone wherein the system is capable of being used as both a telephone and a camera. Further, there is not any disclosure of a system capable of receiving image data signals or other input from outside the unit. Again, assuming that the ‘159 patent discloses such a capability is an application of hindsight from information not available at the time the ‘159 patent was conceived. As with the ‘646 patent and the ‘600

patent, the '159 patent is directed to a means for generating a Group-III fax from a camera collected image.

Claim 43

It is respectfully claim 43 clearly distinguishes and distinctly claims the invention over the '600 patent and the '159 patent, as well.

As Claim 43 states, applicant's invention is directed to a self-contained cellular telephone and integrated image processing system for both sending and receiving telephonic audio signals and for capturing a visual image and transmitting it to a remote receiving station, wherein the image capture comprises a digital camera contained within a unitary housing also containing the telephonic system. There is a viewer for displaying an image framed by the camera, and a self-contained processor in the housing for generating an image data signal representing the image framed by the camera. The telephonic system not only transmits the image data signal but also operates as an audio telephone for sending and receiving digitized audio signals. The invention as described in amended claim 1 includes a keypad for permitting manually input digitized text signals to be input to the processor, the telephonic system being further adapted for sending the digitized alphanumeric signals. The wireless communications device is capable of transmitting any of the digitized signals (image, audio and alphanumeric) to any of a plurality of compatible remote receiving stations. An integrated power supply is included.

It is respectfully submitted that the '646 patent does not disclose a viewer or suggest a viewer or that one would be desirable or necessary in the collection and transmission of a fax image, as contemplated. It is also submitted that the '646 patent does not disclose a system of capable of sending and receiving audio and alphanumeric signals as well as image data signals. Therefore, it is respectfully submitted that the '646 patent neither teaches nor suggests applicant's invention as now recited in amended Claim 1. It is respectfully requested that the rejection under 35 U.S.C. §102(b) be withdrawn.

The '600 patent has the same shortcomings as the '646 patent relative to amended claim 1 and therefore, it is respectfully requested that rejection of Claim 1, as amended, under 35 U.S.C. §102(e) be withdrawn.

The '159 patent discloses a modular system wherein a discrete camera is attached to a discrete computer and the discrete computer is connected to a transmission system. While

one embodiment mentions the use of a camera/telephone combination, however the image created is receivable only at a Group-III fax machine. In addition, there is not any capability for either both receiving and displaying images from a remote system, or for utilizing the telephone in an audio telephone configuration.

New independent Claim 43 is directed to a combination telephone and camera wherein the system can operate as a standard telephone or as a camera or both. The images transmitted are digital photographs not limited to Group-III fax or similar facsimile systems. It is respectfully submitted that the invention as now set forth in Claim 43 is allowable over the art of record.

New Claim 51

New Claim 51 is directed to a cellular telephone having an integrated digital camera for both sending and receiving telephonic audio signals and for capturing a visual image, converting the visual image to a digitized image data signal and transmitting digitized image data signal via a cellular telephone network. The cellular telephone includes a transmitter/receiver for transmitting and receiving audio telephone messages over a cellular network, a keypad for entering manually input alphanumeric signals to be transmitted over the cellular telephone network, and a display window for displaying the manually input alphanumeric signals. An integrated digital camera includes a viewer for visually framing a visual image to be captured, a processor for capturing and digitizing the framed image in a format adapted for transmission over the cellular network via the cellular telephone. An integrated power supply for powering both the cellular telephone and the digital camera.

As discussed above, none of the art of record contemplates the combined camera/telephone as claimed in new Claim 51. It is respectfully submitted that Claim 51 is allowable over the art of record.

New Claim 55

New independent Claim 55 covers a combination cellular telephone and digital camera wherein an integrated system is contained in a single housing having a digital camera, a viewer associated with the camera for displaying an image framed by the camera, a processor for processing the image framed by the camera and for converting it into a digitized image signal, and a cellular telephone adapted for receiving and digitizing audio signals to be transmitted and for converting received digitized audio signals into audio, the

cellular telephone further adapted for transmitting and receiving non-audio digital signals including digitized image signals. A keypad in the housing permits manually input alphanumeric signals to be input into the cellular telephone, the manually input alphanumeric signals being displayed in the viewer. A power supply is provided in the housing for powering the processor, the cellular telephone and the digital camera. An integrated wireless transmitter/receiver provides for transmitting digital signals sent from and receiving digital signals sent to the cellular telephone.

It is respectfully submitted that none of the '646 patent, '600 patent and the '159 patent provides for or remotely suggests wireless transmission and reception of digital image data and the means for displaying the same in a cellular telephone/camera combination as called for in new Claim 55. Wherefore, it is respectfully submitted that such claim is allowable over the art of record.

Remaining Art Specifically Relied On By the Examiner

Ross '194 Patent: This patent shows another system for collecting images via a camera and converting them to a Group-III Fax. In view of the amended claims it is submitted that this reference is not particularly relevant.

Shibita et al '300 Patent: This patent is directed to teleconferencing equipment utilizing desk top units and has the capability of receiving and displaying faxed images in a video teleconference. In view of the amended claims it is submitted that this reference is not particularly relevant.

Bradley et al '041 Patent: This patent shows interconnectivity between ground and satellite based communications systems. In view of the amended claims it is submitted that this reference is not particularly relevant.

**REMARKS**

Applicant and his attorney appreciate the courtesies extended by the Examiner at the interview of December 20, 2004.

As will be noted by the Examiner, new claims have been added in view of the art cited by the Examiner in the Office Action of September 27, 2004. The claims are now more clearly directed to and distinctly point out what applicant believes to be his invention. In addition, in view of the affidavit under 37 CFR 1.131, none of the art is applicable.

Moreover, the subject invention, as supported by the claims as amended are distinct from the art of record. It is respectfully submitted that each of the independent Claims 1, 43, 51 and 55 are now in condition to be allowed.

It is also respectfully submitted that the dependent claims are allowable for the same reasons. It is, therefore, respectfully requested that the Examiner withdraw his rejections of the claims and place this application in condition for allowance.

All of the objections and rejections of the Examiner having been met by the amendments made herein, it is respectfully requested that this case be passed to allowance.

Respectfully submitted,

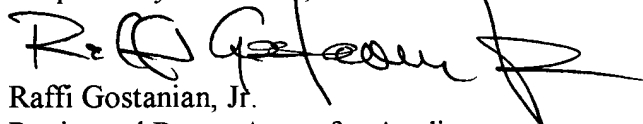

Raffi Gostanian, Jr.  
Registered Patent Agent for Applicant  
Reg. No. 42,595  
(972) 849-1310

Please send all correspondences to:

Robert C. Curfiss  
P.O. Box 903  
Humble, Texas 77347



IN THE UNITED STATES PATENT AND TRADEMARK OFFICE

|   |                       |                              |
|---|-----------------------|------------------------------|
| In re Application of:   | §                     |                              |
| David A. Monroe   | §                     | Group Art Unit: 2622         |
| Serial No.: 10/336,470  | §                     | Examiner: Joseph R. Pokrzywa |
| Filed: January 3, 2003  | §                     | Docket No. 121817.0002.042   |
| For: APPARATUS FOR CAPTURING,<br>CONVERTING AND<br>TRANSMITTING A VISUAL<br>IMAGE SIGNAL VIA A DIGITAL<br>TRANSMISSION SYSTEM | §<br>§<br>§<br>§<br>§ |                              |

Mail Stop RESPONSE/FEE  
 Commissioner for Patents  
 P.O. Box 1450  
 Alexandria, Virginia 22313-1450

LETTER TO THE OFFICE DRAFTSMAN

Please correct Fig. 5 of the drawing in accordance with the enclosed marked up drawing.  
 Namely, change "83" to --83a-- and "81" to --81a--.

Charge any fee to Deposit Account No. 50-3322. A duplicate of this letter is attached for this purpose.

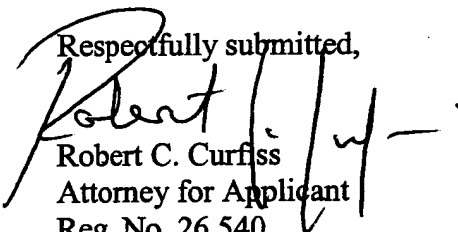
Respectfully submitted,  
  
 Robert C. Curfiss  
 Attorney for Applicant  
 Reg. No. 26,540

Jackson Walker L.L.P.  
 112 E. Pecan Street, Suite 2100  
 San Antonio, Texas 78205  
 Telephone: 713-752-4322  
 Facsimile: 713-752-4221  
 e-mail: rcurfiss@jw.com

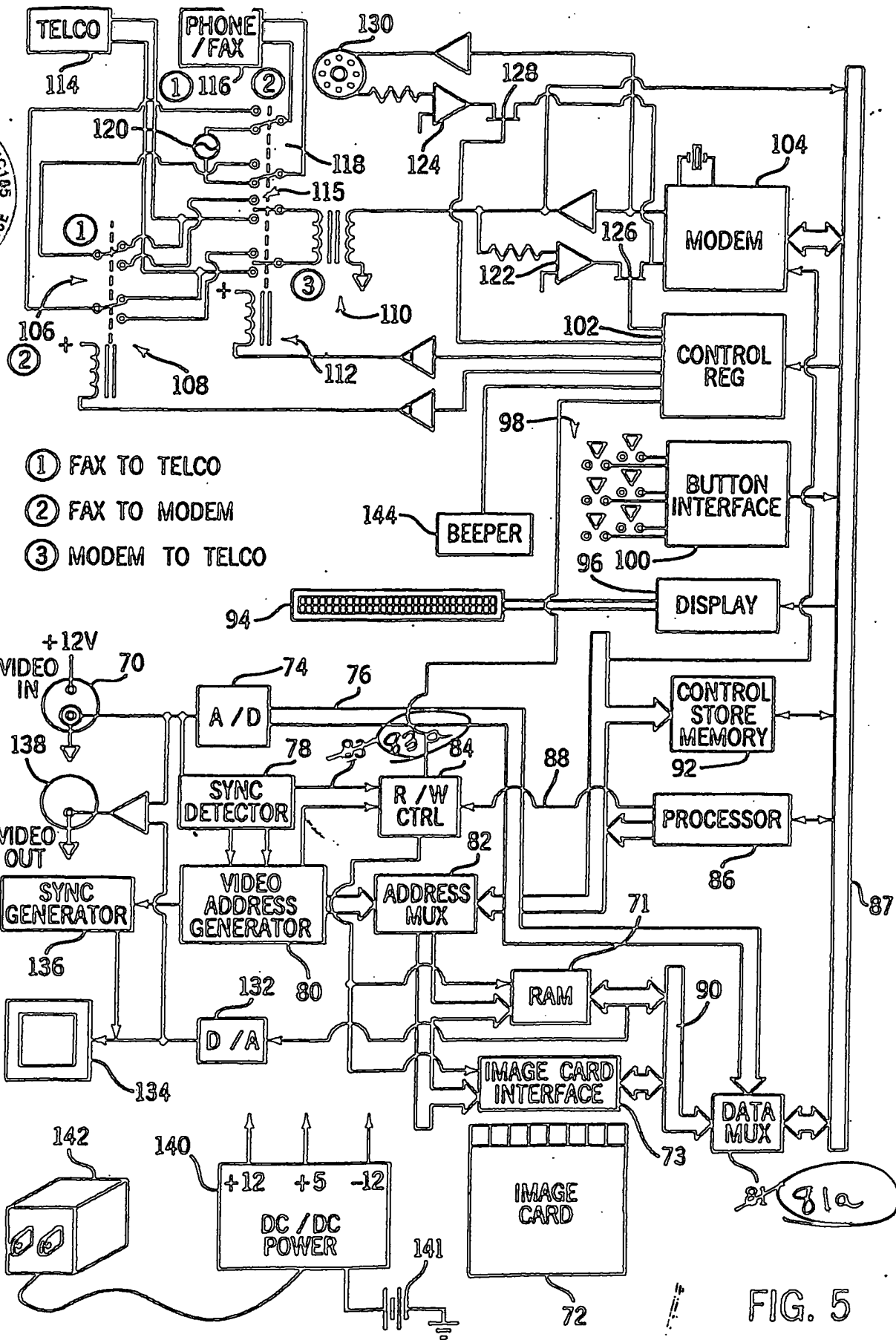

FIG. 5





UNITED STATES PATENT AND TRADEMARK OFFICE

UNITED STATES DEPARTMENT OF COMMERCE  
United States Patent and Trademark Office  
Address: COMMISSIONER FOR PATENTS  
P.O. Box 1450  
Alexandria, Virginia 22313-1450  
www.uspto.gov

| APPLICATION NO. | FILING DATE | FIRST NAMED INVENTOR | ATTORNEY DOCKET NO. | CONFIRMATION NO. |
|-----------------|-------------|----------------------|---------------------|------------------|
| 10/336,470      | 01/03/2003  | David A. Monroe      | 121817.0002.042     | 8448             |

7590 03/31/2005  
Robert C Curfiss  
JACKSON WALKER L.L.P.  
112 E. Pecan Street, Suite 2100  
San Antonio, TX 78205

EXAMINER

POKRZYWA, JOSEPH R

ART UNIT PAPER NUMBER

2622

DATE MAILED: 03/31/2005

Please find below and/or attached an Office communication concerning this application or proceeding.

Notice of Non-Compliant Amendment (37 CFR 1.121)

The amendment document filed on 1/6/05 is considered non-compliant because it has failed to meet the requirements of 37 CFR 1.121. In order for the amendment document to be compliant, correction of the following item(s) is required. **Only the corrected section of the non-compliant amendment document must be resubmitted (in its entirety), e.g., the entire "Amendments to the claims" section of applicant's amendment document must be re-submitted.** 37 CFR 1.121(h).

THE FOLLOWING CHECKED (X) ITEM(S) CAUSE THE AMENDMENT DOCUMENT TO BE NON-COMPLIANT:

- 1. Amendments to the specification:
  - A. Amended paragraph(s) do not include markings.
  - B. New paragraph(s) should not be underlined.
  - C. Other the entire paragraph must be submitted with strike through for deleted text and underlines for new/added text
- 2. Abstract:
  - A. Not presented on a separate sheet. 37 CFR 1.72.
  - B. Other \_\_\_\_\_
- 3. Amendments to the drawings: \_\_\_\_\_
- 4. Amendments to the claims:
  - A. A complete listing of all of the claims is not present.
  - B. The listing of claims does not include the text of all pending claims (including withdrawn claims)
  - C. Each claim has not been provided with the proper status identifier, and as such, the individual status of each claim cannot be identified. Note: the status of every claim must be indicated after its claim number by using one of the following 7 status identifiers: (Original), (Currently amended), (Canceled), (Withdrawn), (Previously presented), (New) and (Not entered).
  - D. The claims of this amendment paper have not been presented in ascending numerical order.
  - E. Other: \_\_\_\_\_

For further explanation of the amendment format required by 37 CFR 1.121, see MPEP Sec. 714 and the USPTO website at <http://www.uspto.gov/web/offices/pac/dapp/opla/preognotice/officeflyer.pdf>.

If the non-compliant amendment is a **PRELIMINARY AMENDMENT**, applicant is given ONE MONTH from the mail date of this letter to supply the corrected section which complies with 37 CFR 1.121. Failure to comply with 37 CFR 1.121 will result in non-entry of the preliminary amendment and examination on the merits will commence without consideration of the proposed changes in the preliminary amendment(s). This notice is not an action under 35 U.S.C. 132, and this ONE MONTH time limit is not extendable.

If the non-compliant amendment is a reply to a **NON-FINAL OFFICE ACTION** (including a submission for an RCE), and since the amendment appears to be a *bona fide* attempt to be a reply (37 CFR 1.135(c)), applicant is given a TIME PERIOD of ONE MONTH from the mailing of this notice within which to re-submit the corrected section which complies with 37 CFR 1.121 in order to avoid abandonment. **EXTENSIONS OF THIS TIME PERIOD ARE AVAILABLE UNDER 37 CFR 1.136(a).**

If the amendment is a reply to a **FINAL REJECTION**, this form may be an attachment to an Advisory Action. The period for response to a final rejection continues to run from the date set in the final rejection, and is not affected by the non-compliant status of the amendment.

T. Riddick  
 Legal Instruments Examiner (LIE)

571-272-7277  
 Telephone No.



In the Claims:

Please amend the claims as follows:

Cancel Claims 5, 6, 10, 11, 14-17, 21, 31-34.

Amend Claim 3 as follows: Line 1, change "1" to --2--.

Add the following new Claims 43-62, as follows:

43 (New). A handheld self-contained cellular telephone and integrated image processing system for both sending and receiving telephonic audio signals and for capturing a visual image and transmitting it to a remote receiving station, the system comprising:

- a. A housing;
- b. An image capture device comprising a electronic camera contained within the housing;
- c. A display for displaying an image framed by the camera;
- d. A processor in the housing for generating an image data signal representing the image framed by the camera;
- e. A telephonic system in the housing for sending and receiving digitized audio signals and adapted for sending the image data signal;
- f. Alphanumeric input keys in the housing for permitting manually input digitized alphanumeric signals to be input to the processor, the telephonic system being further adapted for sending the digitized alphanumeric signals;
- g. A wireless communications device adapted for transmitting any of the digitized signals to a compatible remote receiving station; and
- h. A power supply in the housing for powering the system.

44. (New) The self-contained image processing system of Claim 43, further comprising a display for framing the image to be captured by the image capture device and for displaying the image at the system whereby the operator can view and frame the image prior to capture.

45. (New) The self-contained image processing system of Claim 43, wherein the display is adapted for viewing alphanumeric messages input at the alphanumeric keys.

46. (New) The self-contained image processing system of Claim 43, wherein the communications system is adapted for receiving incoming alphanumeric messages from a remote station and wherein the display is adapted for viewing such incoming alpha numeric messages.

47. (New) The self-contained image processing system of Claim 43, wherein the communications system is adapted for receiving incoming image data signals and wherein the display is adapted for viewing such incoming image data signals.

48. (New) The self-contained image processing system of Claim 43, further comprising a removable memory module adapted to be removably housed in the housing for storing captured image data signals.

49. (New) The self-contained image processing system of Claim 43, wherein the system is adapted for operating in any combination of three distinct functions: (1) an audio telephone, (2) a transmitting system for transmitting captured image data signals via a cellular telephone, and (3) for receiving incoming transmissions such as configuration signals or incoming image data signals.

50. (New) The self-contained image processing system of Claim 49, wherein the display is adapted for viewing incoming image data signals.

51. (New) A handheld cellular telephone having an integrated electronic camera for both sending and receiving telephonic audio signals and for capturing a visual image, converting the visual image to a digitized image data signal and transmitting digitized image data signal via a cellular telephone network, the cellular telephone comprising:

- a. A housing;
- b. A cellular telephone in the housing, the cellular telephone further including a transmitter/receiver for transmitting and receiving audio telephone messages over a cellular network, a keypad for entering manually input alphanumeric signals to be

transmitted over the cellular telephone network, and a display window for viewing the manually input alphanumeric signals;

- c. An electronic camera in the housing, the digitized camera adapted for visually framing a visual image to be captured and for capturing and digitizing the framed image in a format adapted for transmission over the cellular network via the cellular telephone;
- d. An integrated power supply for powering both the cellular telephone and the camera.

52. (New) The cellular telephone of Claim 51, wherein the display window for viewing the alphanumeric signals is within the display for framing the visual image.

53. (New) The cellular telephone of Claim 51, further including a memory in the housing for storing the captured framed image.

54. (New) The cellular telephone of Claim 53, wherein the memory is selectively removable from the housing.

55 (New) A combination of handheld cellular telephone and electronic camera comprising:

- a. A housing;
- b. A electronic camera in the housing;
- c. A display in the housing;
- d. A processor for processing the image framed by the camera;
- e. A cellular telephone in the housing and adapted for accepting and digitizing audio signals to be transmitted and for converting received digitized audio signals into acoustic audio, the cellular telephone further adapted for transmitting and receiving non-audio digital signals including digitized image signals;
- f. Alphanumeric input keys in the housing for permitting manually input alphanumeric signals to be input into the cellular telephone, the manually input alphanumeric signals being presented in a display;

- g. A power supply in the housing for powering the processor, the cellular telephone, the display and the camera;
- h. A wireless transmitter/receiver in the housing for transmitting digital signals sent from and receiving digital signals sent to the cellular telephone.

56 (New) The combination of Claim 55 further comprising a display for framing the image to be captured by the image capture device and for viewing the image at the system whereby the operator can view and frame the image prior to capture.

57 (New) The combination of Claim 55 wherein the display is adapted for viewing alphanumeric messages input at the alphanumeric input keys.

58 (New) The combination of Claim 55, wherein the cellular telephone is adapted for receiving incoming alphanumeric messages from a remote station and wherein the display is adapted for viewing such incoming alphanumeric messages.

59. (New) The combination of Claim 55, wherein the cellular telephone is adapted for receiving incoming image data signals and wherein the display is adapted for viewing such incoming image data signals.

60. (New) The combination of Claim 55, further comprising a removable memory module adapted to be removably housed in the housing for storing captured image data signals.

61. (New) The combination of Claim 60, further adapted for operating in any combination of three distinct functions: (1) an audio telephone, (2) a transmitting system for transmitting captured image data signals via a cellular telephone, and (3) for receiving incoming transmissions such as incoming image data signals.

62. (New) The combination of Claim 60, wherein the display is adapted for viewing incoming image data signals.

## ARGUMENT

The applicant appreciates the thoroughness applied by the Examiner in the examination of the application. After a careful review of the Examiner's comments, Applicant has canceled claims 5, 6, 10, 11, 14-17, 21, 31-34 and has added claims 43-62, including independent claims 43, 51 and 55.

Applicant has amended the errors in the specification as noted by the Examiner. It is respectfully submitted that no new matter has been added in these corrections.

The amendments to the drawings have been made in accordance with the Examiner's recommendations in a separate document filed with the Office Draftsman, concurrently herewith.

In view of the amendments to the claims, the specific objection regarding informalities in Claim 5 is rendered moot, this claim having been canceled.

Claim 3 has been amended in accordance with the requirements of the Examiner.

Applicant has filed concurrently herewith an affidavit under 37 CFR 1.131, establishing an invention date at least earlier than March 23, 1993, more than one year before the filing date of the earliest patent relied upon by the Examiner. The affidavit and exhibits attached thereto clearly establish conception and reduction to practice and confirm due diligence between the conception date and the effective filing date of this application. For this reason, applicant submits that none references cited by the Examiner can be used as prior art in the subject application.

Moreover, as stated in the affidavit, none of these references combine a handheld system with the circuitry to support it, which as indicated in the affidavit, was a years long effort. It is respectfully submitted that the claims, as now pending are allowable in view of the invention date established by applicant and such action is requested.

In any event, applicant has discussed the various rejections made by the Examiner for sake of completion of the record.

Based on the affidavit and the arguments made herein it is respectfully submitted that this application is now in condition for allowance and such action is respectfully solicited.



## Claim Rejections

### Amended Claims Summary

Claims 1, 2, 4-12, 21, 23-27 and 30-36 have been rejected as anticipated by the Hassan et al '646 patent, under 35 U.S.C. §102(b), and anticipated by the Westberger '600 patent under 35 U.S.C §102(e), and anticipated by the Parulski et al '159 patent under 35 U.S.C. §102(e). Since this art is not relevant in view of the 131 Affidavit, this rejection should be withdrawn. However, the Examiner's arguments have been carefully considered in forming the new claims, in particular the new independent claims 43, 52 and 56, as well as original claim 1. The '646 patent, '600 patent and '159 patent will be reviewed with respect to the currently pending claims for sake of completeness of record.

### The Hassan et al '646 Patent

The Examiner has stated the '646 patent "discloses a self-contained image processing system...for capturing a visual image and transmitting it to a remote receiving station...a processor...a communications device...adapted for transmitting the data signal to the remote receiving station and a wireless transmission system between the communications device and the compatible receiving station."

With all due respect, while '646 patent mentions a cellular telephone at Column 2, line 5 and again at Column 2, line 53 and once again at Column 3, line 13, there is never any discussion as to how this may be accomplished. All of the embodiments shown and described in the '646 patent require hard wiring to a land line, as indicated by the RJ-11 jack 130 as shown in Figs. 1 and 2. There is not any discussion as to how the signal may need to be conditioned for transmission over a wireless system. For this reason, it is believed that the '646 patent is not a sound reference for rejection of original Claim 1 under 35 U.S.C. §102(b). In viewing the application for the '646 patent at the time it was filed, the reference to cellular telephone transmission can only be considered to be wishful thinking on the part of Hassan et al. However, in as much as Claim 1 has been substantially amended, applicant respectfully submits that the '646 patent cannot be applied as an anticipatory reference without pursuing the argument relative to wireless interconnectivity.

A clear reading of the '646 patent shows that it is directed to an imaging system adapted for converting an analog camera captured image to a fax data signal for transmission via a fax modem over a wired telephone line. While the '646 patent may suggest other uses,

it does not suggest how such uses may be implemented. Without the application of hindsight the '646 patent cannot be shown to read on anything other than a system utilizing an analog camera to create an image which may be converted to a Group-III fax for transmission over a typical fax modem and land line telephone to a remote recipient Group-III fax machine.

*The Wertsberger '600 Patent*

The Examiner has stated that the Wertsberger '600 patent "discloses a self-contained image processing system...for capturing a visual image and transmitting it to a remote receiving station...with the system comprising an image capture device...a processor...for generating a data signal for representing the image...a communications device...adapted for transmitting the data signal to the remote receiving station...and a wireless transmission system...between the communications device and the compatible receiving station."

Applicant does not disagree generally with this interpretation of the '600 patent. However, applicant would like to note, for the record, that only mention of wireless interconnectivity is at Column 5, lines 1-6, wherein it is stated:

"The Fax Modem Circuitry [13] is connected to Telephone Interface Circuitry [15] that allows the Fax Camera to connect to a public switched telephone network, or a cellular telephone communication link. Additionally, cellular telephone circuitry [70] may be built into the fax camera to provide self contained communications capability."

It is respectfully submitted that this reference to cellular technology does not disclose a system that is adapted for generating a data signal in an integrated unit for transmission over a wireless network. In order for the system to work as shown and described, it must be hardwired to something. There simply is not disclosed any wireless gateway.

In essence, the '600 patent discloses a camera with a digital convertor for generating a Group-III fax for transmission over a standard fax modem and which is hardwired to a telephone interface circuit (see, in particular, Fig. 1).

*Parulski et al '159 Patent*

The Examiner has stated that the Parulski '159 patent discloses "a self-contained image processing system...for capturing a visual image and transmitting it to a remote receiving station...with the system comprising an image capture device...a processor for generating a data signal representing the image...a communications device...adapted for

transmitting the data signal to the remote receiving communications device and the compatible receiving station.”

The ‘159 patent discloses an electronic camera system for selectively transmitting electronic image data to a plurality of remote base units. The camera module is detachably coupled to a computer having a display screen and a data entry device. Basically, this patent discloses a mechanism for connecting a camera to a computer with a display screen. The image data is then loaded into the computer and a transmitter associated with the computer is utilized transmit the data to remote locations. There is a so-called camera/telephone embodiment shown in Fig. 7. As stated in the ‘159 patent, at Column 4, lines 26-53:

“A second embodiment of the invention is illustrated, in FIGS. 7 and 8. In this embodiment, a cellular telephone is provided with the components of an electronic image camera to form a combined telephone/camera unit 48. The top of the combined unit 48 includes a lens 50, a flip-up flash unit 52, and an antenna 54. The front face of the combined unit 48 is provided with a liquid crystal display screen 56 and a telephone keypad 58, both of which are coupled to an internal bus 60 along with a control processing unit 62, memory unit 64, and cellular transceiver 66 as shown in FIG. 9. The internal bus 60 is also connected to a camera module 68, which includes the same basic components as illustrated in FIG. 4, with the exception that the output from the image signal processor is supplied directly to the internal bus 60 instead of a connector.

In operation, as illustrated in greater detail by the flow diagram illustrated in FIG. 10, the user takes a picture by flipping up the flash unit 52 and pressing an image capture switch (not shown). Alternatively, a key (for example the # key) on the keypad 58 can be utilized as the image capture switch in an image capture mode of operation. The digitized picture data generated by the camera module 68 is stored in the memory unit 64 and displayed on the display screen 56. To transmit the image, the user dials the telephone number of a desired fax machine that is to receive the image using the keypad 58. The number is transmitted to the fax machine via the cellular transceiver 66.”

It should be noted that the “159 patent does not disclose, nor does it suggest the use of a combined camera and cellular telephone wherein the system is capable of being used as both a telephone and a camera. Further, there is not any disclosure of a system capable of receiving image data signals or other input from outside the unit. Again, assuming that the ‘159 patent discloses such a capability is an application of hindsight from information not available at the time the ‘159 patent was conceived. As with the ‘646 patent and the ‘600

patent, the '159 patent is directed to a means for generating a Group-III fax from a camera collected image.

Claim 43

It is respectfully claim 43 clearly distinguishes and distinctly claims the invention over the '600 patent and the '159 patent, as well.

As Claim 43 states, applicant's invention is directed to a self-contained cellular telephone and integrated image processing system for both sending and receiving telephonic audio signals and for capturing a visual image and transmitting it to a remote receiving station, wherein the image capture comprises a digital camera contained within a unitary housing also containing the telephonic system. There is a viewer for displaying an image framed by the camera, and a self-contained processor in the housing for generating an image data signal representing the image framed by the camera. The telephonic system not only transmits the image data signal but also operates as an audio telephone for sending and receiving digitized audio signals. The invention as described in amended claim 1 includes a keypad for permitting manually input digitized text signals to be input to the processor, the telephonic system being further adapted for sending the digitized alphanumeric signals. The wireless communications device is capable of transmitting any of the digitized signals (image, audio and alphanumeric) to any of a plurality of compatible remote receiving stations. An integrated power supply is included.

It is respectfully submitted that the '646 patent does not disclose a viewer or suggest a viewer or that one would be desirable or necessary in the collection and transmission of a fax image, as contemplated. It is also submitted that the '646 patent does not disclose a system of capable of sending and receiving audio and alphanumeric signals as well as image data signals. Therefore, it is respectfully submitted that the '646 patent neither teaches nor suggests applicant's invention as now recited in amended Claim 1. It is respectfully requested that the rejection under 35 U.S.C. §102(b) be withdrawn.

The '600 patent has the same shortcomings as the '646 patent relative to amended claim 1 and therefore, it is respectfully requested that rejection of Claim 1, as amended, under 35 U.S.C. §102(e) be withdrawn.

The '159 patent discloses a modular system wherein a discrete camera is attached to a discrete computer and the discrete computer is connected to a transmission system. While

one embodiment mentions the use of a camera/telephone combination, however the image created is receivable only at a Group-III fax machine. In addition, there is not any capability for either both receiving and displaying images from a remote system, or for utilizing the telephone in an audio telephone configuration.

New independent Claim 43 is directed to a combination telephone and camera wherein the system can operate as a standard telephone or as a camera or both. The images transmitted are digital photographs not limited to Group-III fax or similar facsimile systems. It is respectfully submitted that the invention as now set forth in Claim 43 is allowable over the art of record.

New Claim 51

New Claim 51 is directed to a cellular telephone having an integrated digital camera for both sending and receiving telephonic audio signals and for capturing a visual image, converting the visual image to a digitized image data signal and transmitting digitized image data signal via a cellular telephone network. The cellular telephone includes a transmitter/receiver for transmitting and receiving audio telephone messages over a cellular network, a keypad for entering manually input alphanumeric signals to be transmitted over the cellular telephone network, and a display window for displaying the manually input alphanumeric signals. An integrated digital camera includes a viewer for visually framing a visual image to be captured, a processor for capturing and digitizing the framed image in a format adapted for transmission over the cellular network via the cellular telephone. An integrated power supply for powering both the cellular telephone and the digital camera.

As discussed above, none of the art of record contemplates the combined camera/telephone as claimed in new Claim 51. It is respectfully submitted that Claim 51 is allowable over the art of record.

New Claim 55

New independent Claim 55 covers a combination cellular telephone and digital camera wherein an integrated system is contained in a single housing having a digital camera, a viewer associated with the camera for displaying an image framed by the camera, a processor for processing the image framed by the camera and for converting it into a digitized image signal, and a cellular telephone adapted for receiving and digitizing audio signals to be transmitted and for converting received digitized audio signals into audio, the

cellular telephone further adapted for transmitting and receiving non-audio digital signals including digitized image signals. A keypad in the housing permits manually input alphanumeric signals to be input into the cellular telephone, the manually input alphanumeric signals being displayed in the viewer. A power supply is provided in the housing for powering the processor, the cellular telephone and the digital camera. An integrated wireless transmitter/receiver provides for transmitting digital signals sent from and receiving digital signals sent to the cellular telephone.

It is respectfully submitted that none of the '646 patent, '600 patent and the '159 patent provides for or remotely suggests wireless transmission and reception of digital image data and the means for displaying the same in a cellular telephone/camera combination as called for in new Claim 55. Wherefore, it is respectfully submitted that such claim is allowable over the art of record.

*Remaining Art Specifically Relied On By the Examiner*

Ross '194 Patent: This patent shows another system for collecting images via a camera and converting them to a Group-III Fax. In view of the amended claims it is submitted that this reference is not particularly relevant.

Shibita et al '300 Patent: This patent is directed to teleconferencing equipment utilizing desk top units and has the capability of receiving and displaying faxed images in a video teleconference. In view of the amended claims it is submitted that this reference is not particularly relevant.

Bradley et al '041 Patent: This patent shows interconnectivity between ground and satellite based communications systems. In view of the amended claims it is submitted that this reference is not particularly relevant.

**REMARKS**

Applicant and his attorney appreciate the courtesies extended by the Examiner at the interview of December 20, 2004.

As will be noted by the Examiner, new claims have been added in view of the art cited by the Examiner in the Office Action of September 27, 2004. The claims are now more clearly directed to and distinctly point out what applicant believes to be his invention. In addition, in view of the affidavit under 37 CFR 1.131, none of the art is applicable.

Moreover, the subject invention, as supported by the claims as amended are distinct from the art of record. It is respectfully submitted that each of the independent Claims 1, 43, 51 and 55 are now in condition to be allowed.

It is also respectfully submitted that the dependent claims are allowable for the same reasons. It is, therefore, respectfully requested that the Examiner withdraw his rejections of the claims and place this application in condition for allowance.

All of the objections and rejections of the Examiner having been met by the amendments made herein, it is respectfully requested that this case be passed to allowance.

Respectfully submitted,

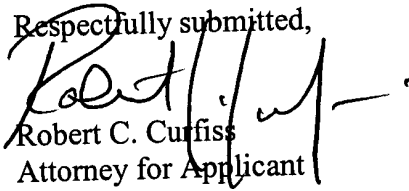
  
Robert C. Curfiss  
Attorney for Applicant  
Reg. No. 26,540

Jackson Walker L.L.P.  
112 E. Pecan Street, Suite 2100  
San Antonio, Texas 78205  
Telephone: 713-752-4322  
Facsimile: 713-752-4221  
e-mail: rcurfiss@jw.com

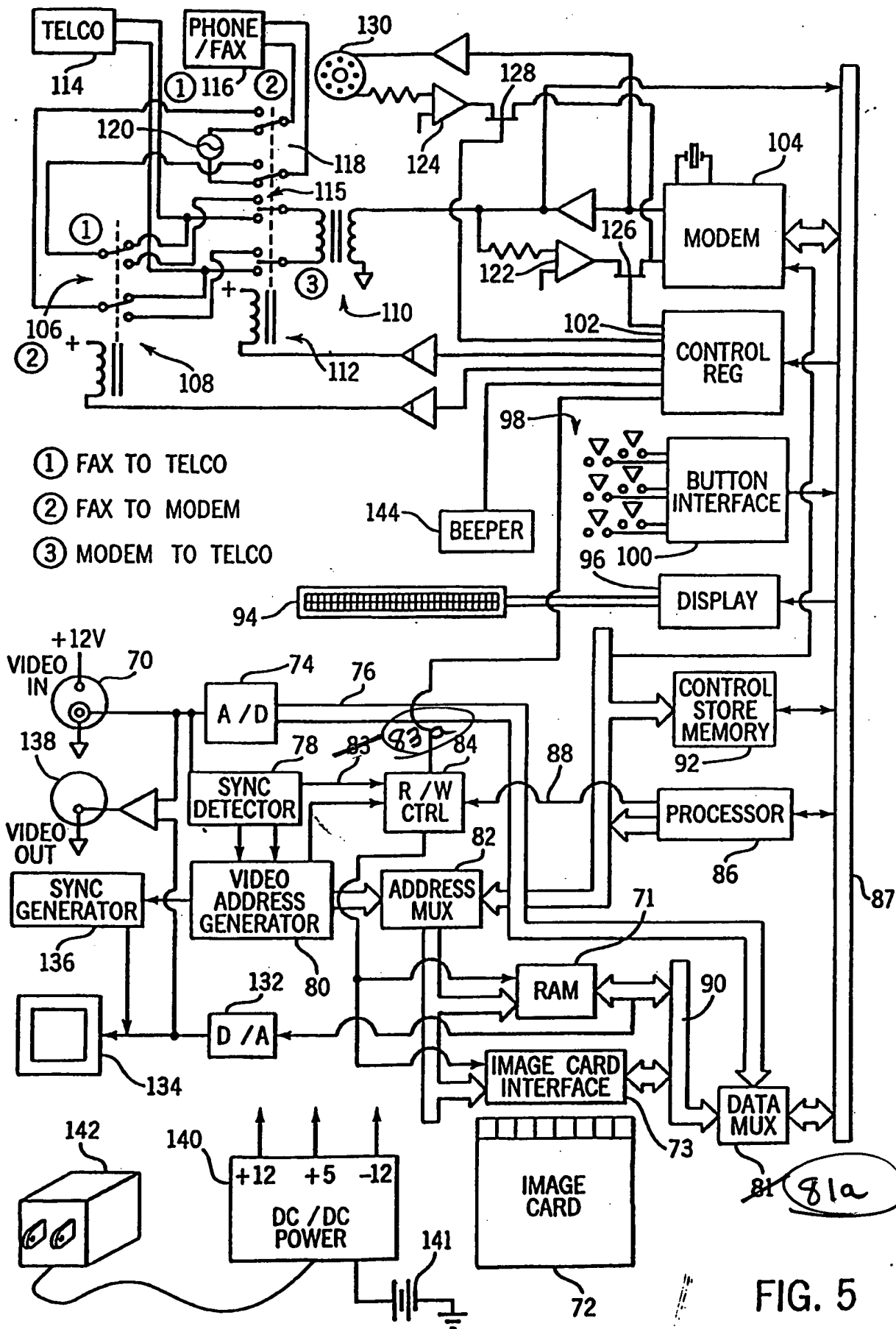

FIG. 5



**CLEAN VERSION OF THE PENDING CLAIMS IN PROPOSED ORDER**

1. A self-contained image processing system for capturing a visual image and transmitting it to a remote receiving station, the image processing system comprising:
  - a. an image capture device;
  - b. a processor for generating a data signal representing the image;
  - c. a communications device adapted for transmitting the data signal to the remote receiving station;
  - d. a wireless transmission system between the communications device and the compatible receiving station.
  
2. The image processing system of claim 1, further including a memory for receiving and storing the data signal, and wherein the communications device is adapted for recalling the stored data signal from memory.
  
3. The image processing system of claim 2, wherein said memory is a removable random access medium and wherein the system is adapted for selectively charging and discharging the memory.
  
4. The image processing system of claim 1, wherein the image capture device is an analog camera for generating an analog image signal and there is further included an analog to digital converter for converting the analog image signal to a digital signal.
  
7. The image processing system of claim 1, wherein there is further included an integrated wireless telephone associated with the communications device.
  
8. The image processing system of claim 1, further comprising a housing for housing all of the elements of the system in an integrated body.
  
9. The image processing system of claim 1, wherein said image capture device is a digital camera.

12. The image processing system of claim 1, wherein the processor is adapted for generating a signal in any of a plurality of selected protocols and wherein the communications device is adapted for transmitting the signal in the proper protocol to a remote, compatible receiving station.

13. The image processing system of claim 1, wherein:

a. the image capture device is an analog video camera for generating a video signal;

b. the processor further comprises:

i. an analog to digital converter;

ii. a sync detector and a video address generator for synchronizing the digital signal with the analog signal for defining the beginning and end of the signal to define a still frame;

iii. a random access memory for receiving and storing the converted, synchronized signal frame-by-frame;

iv. a processor routine for converting the signals stored in the memory to a protocol adapted for transmission to a remote, compatible protocol receiving station;

c. a communications device for transmitting the signal in the proper protocol to the compatible receiving station.

18. The image processing system of claim 13, further including an integral view for viewing the images stored in the memory.

19. The image processing system of claim 13, wherein the memory is a removable memory medium which may be selectively removed from the system.

20. The image processing system of claim 19, wherein the removable memory medium comprises a PCMCIA card memory.

22. The image processing system of claim 1, further comprising an audio signal capture device adapted for capturing an audio signal in correlation with the captured video signal.

23. The image processing system of claim 1, further comprising a data processor for creating a text data signal associated with said image data signal.
24. The image processing system of claim 23, further including an input device for providing text data to the data processor.
25. The image processing system of claim 24, wherein the input device is user controlled.
26. The image processing system of claim 25, wherein said user controlled input device is an integral keyboard.
27. The image processing system of claim 24, said input device comprising a real time clock.
28. The image processing system of claim 24, said input device comprising a global positioning system.
29. The image processing system of claim 24, wherein said image data signal is stored in a raw video format.
30. The image processing system of claim 2, wherein the image data signal is stored in a compressed format.
35. The image processing system of claim 1, wherein the remote receiving station is a digital device and the image data is digital.
36. The image processing system of claim 1, further comprising a self-contained power source for powering the system.

37. The image processing system of claim 36, wherein said communications device is adapted to be used independently of the image capture device and the processor, and wherein the power supply is adapted for isolating the power to the communications device from the power to the image capture device and processor.

38. The image processing system of claim 37, further including a power initiation device associated with the image capture device and the processor wherein the power to the image capture device and the processor is off when the initiation device is not activated.

39. The image processing system of claim 38, wherein the power initiation device is user controlled.

40. The image processing system of claim 38, further including a trigger device for activating the power initiation device.

41. The image processing system of claim 40, wherein the trigger device is a timer.

42. The image processing system of claim 40, wherein the trigger device is triggered by the presence of an image to be captured.

43. A handheld self-contained cellular telephone and integrated image processing system for both sending and receiving telephonic audio signals and for capturing a visual image and transmitting it to a remote receiving station, the system comprising:

- a. A housing;
- b. An image capture device comprising a electronic camera contained within the housing;
- c. A display for displaying an image framed by the camera;
- d. A processor in the housing for generating an image data signal representing the image framed by the camera;

- e. A telephonic system in the housing for sending and receiving digitized audio signals and adapted for sending the image data signal;
  - f. Alphanumeric input keys in the housing for permitting manually input digitized alphanumeric signals to be input to the processor, the telephonic system being further adapted for sending the digitized alphanumeric signals;
  - g. A wireless communications device adapted for transmitting any of the digitized signals to a compatible remote receiving station; and
  - h. A power supply in the housing for powering the system.
44. The self-contained image processing system of Claim 43, further comprising a display for framing the image to be captured by the image capture device and for displaying the image at the system whereby the operator can view and frame the image prior to capture.
45. The self-contained image processing system of Claim 43, wherein the display is adapted for viewing alphanumeric messages input at the alphanumeric keys.
46. The self-contained image processing system of Claim 43, wherein the communications system is adapted for receiving incoming alphanumeric messages from a remote station and wherein the display is adapted for viewing such incoming alpha numeric messages.
47. The self-contained image processing system of Claim 43, wherein the communications system is adapted for receiving incoming image data signals and wherein the display is adapted for viewing such incoming image data signals.
48. The self-contained image processing system of Claim 43, further comprising a removable memory module adapted to be removably housed in the housing for storing captured image data signals.

49. The self-contained image processing system of Claim 43, wherein the system is adapted for operating in any combination of three distinct functions: (1) an audio telephone, (2) a transmitting system for transmitting captured image data signals via a cellular telephone, and (3) for receiving incoming transmissions such as configuration signals or incoming image data signals.

50. The self-contained image processing system of Claim 49, wherein the display is adapted for viewing incoming image data signals.

51. A handheld cellular telephone having an integrated electronic camera for both sending and receiving telephonic audio signals and for capturing a visual image, converting the visual image to a digitized image data signal and transmitting digitized image data signal via a cellular telephone network, the cellular telephone comprising:

- a. A housing;
- b. A cellular telephone in the housing, the cellular telephone further including a transmitter/receiver for transmitting and receiving audio telephone messages over a cellular network, a keypad for entering manually input alphanumeric signals to be transmitted over the cellular telephone network, and a display window for viewing the manually input alphanumeric signals;
- c. An electronic camera in the housing, the digitized camera adapted for visually framing a visual image to be captured and for capturing and digitizing the framed image in a format adapted for transmission over the cellular network via the cellular telephone;
- d. An integrated power supply for powering both the cellular telephone and the camera.

52. The cellular telephone of Claim 51, wherein the display window for viewing the alphanumeric signals is within the display for framing the visual image.

53. The cellular telephone of Claim 51, further including a memory in the housing for storing the captured framed image.

54. The cellular telephone of Claim 53, wherein the memory is selectively removable from the housing.

55. A combination of handheld cellular telephone and electronic camera comprising:

- a. A housing;
- b. A electronic camera in the housing;
- c. A display in the housing;
- d. A processor for processing the image framed by the camera;
- e. A cellular telephone in the housing and adapted for accepting and digitizing audio signals to be transmitted and for converting received digitized audio signals into acoustic audio, the cellular telephone further adapted for transmitting and receiving non-audio digital signals including digitized image signals;
- f. Alphanumeric input keys in the housing for permitting manually input alphanumeric signals to be input into the cellular telephone, the manually input alphanumeric signals being presented in a display;
- g. A power supply in the housing for powering the processor, the cellular telephone, the display and the camera;
- h. A wireless transmitter/receiver in the housing for transmitting digital signals sent from and receiving digital signals sent to the cellular telephone.

56. The combination of Claim 55, further comprising a display for framing the image to be captured by the image capture device and for viewing the image at the system whereby the operator can view and frame the image prior to capture.

57. The combination of Claim 55, wherein the display is adapted for viewing alphanumeric messages input at the alphanumeric input keys.

58. The combination of Claim 55, wherein the cellular telephone is adapted for receiving incoming alphanumeric messages from a remote station and wherein the display is adapted for viewing such incoming alphanumeric messages.

59. The combination of Claim 55, wherein the cellular telephone is adapted for receiving incoming image data signals and wherein the display is adapted for viewing such incoming image data signals.

60. The combination of Claim 55, further comprising a removable memory module adapted to be removably housed in the housing for storing captured image data signals.

61. The combination of Claim 60, further adapted for operating in any combination of three distinct functions: (1) an audio telephone, (2) a transmitting system for transmitting captured image data signals via a cellular telephone, and (3) for receiving incoming transmissions such as incoming image data signals.

62. The combination of Claim 60, wherein the display is adapted for viewing incoming image data signals.

3760966v.1





|                                |                   |               |
|--------------------------------|-------------------|---------------|
| U.S. Pat. No. 5,854,694        | October 17, 1995  | NOT CITED     |
| U.S. Pat. No. 5,893,037        | December 9, 1994  | NOT CITED     |
| U.S. Pat. No. 5,517,683        | January 18, 1995  | NOT CITED     |
| U.S. Pat. No. 5,711,013        | January 18, 1995  | NOT CITED     |
| U.S. Pat. No. 5,666,159        | April 24, 1995    | SN 10/336,470 |
| U.S. Pat. No. 5,793,416        | December 29, 1995 | SN 10/326,503 |
| U.S. Pat. No. 5,825,408        | March 18, 1994    | SN 10/326,503 |
| U.S. Pat. No. 5,893,037        | December 9, 1994  | SN 10/326,503 |
| U.S. Pat. No. 5,929,901        | October 6, 1997   | NOT CITED     |
| U.S. Pat. No. 5,995,041        | December 30, 1996 | SN 10/336,470 |
| U.S. Pat. No. 5,969,750        | September 4, 1996 | SN 10/326,503 |
| U.S. Pat. No. 6,072,600        | January 30, 1996  | SN 10/336,470 |
| U.S. Pat. No. 5,806,005        | May 10, 1996      | SN 10/326,503 |
| U.S. Pat. No. 5,864,766        | August 13, 1996   | NOT CITED     |
| U.S. Pat. No. 6,043,839        | January 12, 1998  | NOT CITED     |
| U.S. Pat. No. 6,085,112        | November 7, 1996  | NOT CITED     |
| U.S. Pat. No. 6,111,863        | December 29, 1995 | SN 10/326,503 |
| U.S. Pat. No. 6,122,526        | April 24, 1997    | NOT CITED     |
| PCT Publication<br>WO 97/26744 | July 24, 1997     | SN 10/326,503 |
| U.S. Pat. No. 6,181,954        | January 12, 1998  | SN 10/326,503 |
| U.S. Pat. No. 6,452,626        | October 6, 1997   | NOT CITED     |

5. The earliest effective date of any of the 131 Prior Art is March 18, 1994. My invention date for each of the inventions shown and described in the subject applications is more than one year earlier than the earliest effective date of any of the 131 Prior Art, namely, earlier than March 18, 1993. This is supported by the schematic drawings Exhibits 10 and 11, that are dated earlier than March 18, 1993, and by the design renderings and sketches contained in Exhibits 7, 8, and 9, all of which are dated earlier than March 18, 1993.
6. During the period from the date of the inventions to the filing date of January 12, 1998 I was diligent in pursuing the invention and did not abandon the inventions. During this period the invention conceived and shown in Exhibits 6-16 was continually refined and revised, primarily in an effort to achieve a viable commercial product that met all the requirements of the inventions while at the same time being feasible. Commercial success demanded meeting both acceptable performance criteria and financial (cost) criteria.
7. I began working with the concept of sending image data over transmission systems as early as 1983. In 1983 I developed the "PhotoPhone™", a pioneering desktop device ultimately was extensively used and thrived as an early "tele-radiology" system for the transmission of medical X-Ray images, see Exhibit 1.
8. In 1985 I started a company called PhotoTelesis that focused on extending the PhotoPhone to specific Government applications. In 1986 I extended this desktop technology to enable transmission over radio circuits, including cellular. This was done by the addition of a cellular/radio interface circuit board called "CIS", see Exhibit 2. On May 26, 1986, a press release was released that discussed several new products that were announced at the Armed Forces Communication and Electronics Associations in Washington, D.C. The Com-RIT™ product included the CIS board and provided image transmission from a desktop unit over mobile telephones and portable satellite terminals, see Exhibit 3.
9. Over the next several years, I developed several Remote Image Transceivers or R.I.T.'s for the United States Military, see Exhibit 4, and as shown and described in the 1987 Business Plan of my company PhotoTelesis, see Exhibit 5. In 1989 I conceived the circuitry for a concept model R.I.T. which could be handheld, see Exhibit 6. Over the next several years I continued to develop the handheld R.I.T. while continuing to work on, develop and build the military R.I.T. systems such as those shown in the 1986 Business Plan, Exhibit 5. Evidence of this continuing effort is the design concept drawings of Exhibits 7 and 8, dated 1990. Additional concepts were generated during 1991 (Exhibit 9). In addition, in 1991, the first detailed schematic was generated (Exhibit 10), which would permit a prototype circuit to be built.

10. I perceived that a small, handheld image RIT was needed and in 1989 I conceived the circuit architecture for a concept model R.I.T. that could be handheld, see Exhibit 6. This design, although functionally viable, was in practice power hungry and slow in performance. Over the next several years I continued my efforts to develop the handheld R.I.T. while continuing to work on, develop and build the larger specialized tactical military R.I.T. systems such as those shown in the 1987 Business Plan, Exhibit 5. Evidence of this continuing effort are the design concept drawings generated in corroboration with an industrial designer shown in Exhibits 7 and 8, dated 1990. In addition, in 1991 I developed the enhanced architecture that enabled the first detailed schematic (Exhibit 10), which would permit a higher performance and low-power prototype circuit to be built.
11. In 1992, the first comprehensive circuit was completed for a handheld R.I.T., as shown in Exhibit 11. This circuit became Fig. 8 of U.S. Application No. 10/336,470. Continued work done in 1992 on a packaging modification that would be more desirable to Government Customers, as is shown in Exhibits 12 and 13. Some of the design concepts of the 1992 and earlier period were also included in the Government model as was shown in the Application. Compare, for example, Fig. 6 in the application to the 1992 concept drawings Exhibits 12 and 13.
12. Over the next several years, 1993-1997, Photo-Telesis became the standard R.I.T. for Government tactical image transmission. The tactical systems developed and commercialized by PhotoTelesis were employed by the U.S. Government in many systems. Many of the products developed and sold by PhotoTelesis followed the concepts shown and described in the 1987 Business Plan (Exhibit 5).
13. During this time, I continued to be interested in and continued to develop the concept of a true handheld R.I.T. product. In fact, I came up with a formal proposal of a handheld R.I.T. in 1995 and put together a concept proposal in November, 1995 (Exhibit 14), using secure radio transmission. Ultimately this project was never Government funded, I went on to fund and develop a commercially feasible handheld R.I.T. that was first publicly disclosed in late 1997 and first sold to the Government in 1998.
14. While the proposal shown in Exhibit 14 did not feature a cellular telephone compatible R.I.T., it was architecturally consistent and a development stepping-stone toward that goal. The final product incorporated my design concepts of 1993 and earlier, and did include cellular telephone compatibility. A first prototype of this product is embodied in physical Exhibit 15. Physical Exhibit 15, which was shown to the Examiner in charge of prosecution of each subject cases during an interview, is a prototype of the first commercial embodiment of the invention. This was completed in mid-1997 and was first publicly disclosed sometime early 1998. Photographs of this one-of-a-kind prototype are contained in this record as Exhibit 15.
15. The circuitry for supporting the product resulting from the 1995 proposal is provided in the schematics of Exhibit 16, which ultimately became Fig. 5 of Application No. 10/326,503.

16. The product based on the prototype (Exhibit 15 and Exhibit 16) was put into production and sold to the Government. One of the production units, Physical Exhibit 17 as is photographed in Exhibit 17, was demonstrated transmitting over cellular telephone to the Examiner.
17. As shown by the Exhibits attached hereto, I conceived the invention at least as early as March 18, 1993 and worked diligently in developing a commercially viable product culminating in the first commercial handheld R.I.T. in late 1997. This handheld R.I.T. used cellular telephone transmission technology, as evidenced by Exhibits 15-17 as first conceived and document as early as March 18, 1993, see Exhibits (6 -13).
18. The subject applications were timely filed, being within one year of the first public disclosure of the inventions, and in fact, prior to any public disclosure.
19. The above facts establish reduction to practice prior to the earliest effective dates of the 131 Prior Art, or as a minimum, establish conception of the invention prior to the earliest effective date of the 131 Prior Art coupled with due diligence from prior to this date to a subsequent reduction of practice culminating in the prototype of the commercial embodiment Exhibit 15 in mid-1997.

Further affiant sayeth naught.

Executed this 27<sup>th</sup> day of December, 2004, by:

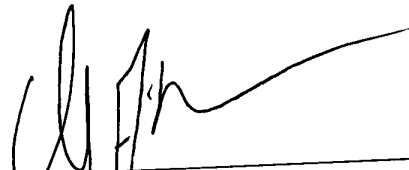
  
\_\_\_\_\_  
David A. Monroe





5/26/86

# PHOTOTELESIS

Remote Image Transmission Systems

OK DAM  
OK [Signature]

Press Release  
For Immediate Release

## PhotoTelesis and Image Data Sign Agreement

### Secure Remote Image Transmission over Telephone & Tactical Transceivers

May 26, 1986. San Antonio, TX. Secure video image transmission between any remote sites over telephone, wireless radio and satellite circuits are now possible through an agreement between Image Data Corporation, makers of the commercial Photophone, and PhotoTelesis.

PhotoTelesis is a San Antonio based video systems integration company supplying video teleconferencing rooms, video teleconferencing equipment and specializing in image transmission equipment for government applications. The agreement makes PhotoTelesis the official vendor of Photophones specially adapted for Government applications.

PhotoTelesis introduced three new product lines at the Armed Forces Communcation and Electronics Association annual Convention and Exposition May 27, 28, and 29 at the Washington D.C. Convention Center. Three special versions of the commercially successful Photophone are produced and marketed by PhotoTelesis. All enable freeze frame monochrome video pictures to be transmitted in seconds over various carriers. They are called RITs - for Remote Image Transceivers.

Tac-RIT™ transmits images over secure tactical line of sight and satellite receivers. Since the units are compatible with current standard military radio transceivers, fast reliable visual communication can now be added to tactical communication and command centers.

Sec-RIT™ is compatible with secure (encrypted) COMSEC gear, including STU II, STU III, and PSV (Personal Secure Voice) secure telephones over common dial-up lines.

801 Lincoln Center 7800 IH 10 West San Antonio, Texas 78230 (512) 349-2020



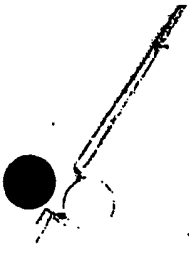

# PHOTOTELESIS

*Remote Image Transmission Systems*

**News Release**

---

Page Two

The PhotoTelesis units offer the additional advantages of allowing voice and video over the same channel, enabling discussion of the picture. An interactive pointer controlled by either party allows discussion of the document as though the two parties were across the table from each other rather than half-way around the world.

PhotoTelesis will introduce three new product lines of RITs at the Armed Forces Communication and Electronics Association annual Convention and Exposition May 27, 28, and 29 at the Washington D.C. Convention Center.

**Tac-RIT™** transmits images over secure tactical line of sight and satellite receivers. Since the units are compatible with current standard military radio transceivers, fast reliable visual communication can now be added to tactical communication and command centers.

**Sec-RIT™** is compatible with secure (encrypted) COMSEC gear, including STU II, STU III, and PSV (Personal Secure Voice) secure telephones over common dial-up lines.

**Com-RIT™** provides compatibility with non-secure mobile cellular telephones and private portable carrier satellite communication systems.

PhotoTelesis is a San Antonio based video systems integration company supplying video teleconferencing rooms, video teleconferencing equipment and specializing in image transmission equipment for government applications.

**PHOTOTELEESIS**  
***Business Plan***

1987

PHOTOTELEESIS Business Overview Copy # \_\_\_\_\_

January 27, 1987

The information contained in this memorandum concerning image transmission products for government applications is furnished to the recipient on a confidential basis for the recipient's exclusive use. By acceptance of this confidential memorandum the recipient agrees not to transmit, divulge, reproduce, or make available to anyone other than himself, this confidential memorandum and any exhibits and documents supplied in connection therewith. *Violation of this confidentiality requirement may place the recipient and the preparers of this document in violation of the Texas and Federal securities laws and the applicable securities laws of other states.*

Any decision to invest in this enterprise should be deferred until the recipient has had the opportunity to review a confidential private placement memorandum now in the process of completion which will describe the specific terms under which an investment may be made and the substantial risks involved in any such investment in addition to any risks which may be described herein.

Prior to the sale of any securities related to the corporation described herein, the preparers of this memorandum will undertake to make available to the recipient hereof the same kind of information that is specified in Schedule A of the Securities Act of 1933, to the extent such persons possess such information or can acquire it without unreasonable effort or expense.

Signature

**PHOTOTELEESIS Business Overview Copy # \_\_\_\_\_**

**January 27, 1987**

The information contained in this memorandum concerning image transmission products for government applications is furnished to the recipient on a confidential basis for the recipient's exclusive use. By acceptance of this confidential memorandum the recipient agrees not to transmit, divulge, reproduce, or make available to anyone other than himself, this confidential memorandum and any exhibits and documents supplied in connection therewith. *Violation of this confidentiality requirement may place the recipient and the preparers of this document in violation of the Texas and Federal securities laws and the applicable securities laws of other states.*

Any decision to invest in this enterprise should be deferred until the recipient has had the opportunity to review a confidential private placement memorandum now in the process of completion which will describe the specific terms under which an investment may be made and the substantial risks involved in any such investment in addition to any risks which may be described herein.

Prior to the sale of any securities related to the corporation described herein, the preparers of this memorandum will undertake to make available to the recipient hereof the same kind of information that is specified in Schedule A of the Securities Act of 1933, to the extent such persons possess such information or can acquire it without unreasonable effort or expense.

Signature

---

# CONTENTS

---

---

---

Executive Summary

About the Company

The Market

Competition

Marketing

Technology

Products

TEMPEST

Risks

Contracts and Agreements

Financials

Appendix

---

# EXECUTIVE SUMMARY

---

---

## ***Overview***

The charter of PHOTOTELESIS is to provide advanced image communications and processing systems to the U.S. Federal Government market. These systems are being developed using proprietary technology and integration of industry-standard components. The company provides total solutions to its customers including development, integration, manufacturing, marketing, support and training, using resources within the company as well as external contract resources.

The PHOTOTELESIS product line permits the capture, manipulation, storage and communication of images, documents and graphics using advanced techniques which permit communication to take place over ordinary voice grade telephone lines or specialized radio or satellite circuits.

The company specializes in providing products which may be connected to U.S. Government approved encryption devices, permitting secure (scrambled) operation over a variety of existing equipment designed for secure voice communications. PHOTOTELESIS also provides specialized packaging of its products to meet needs in desktop, airborne, naval and vehicular environments.

The company's objective is to develop its business to achieve annual revenues of over \$7 million by the end of fiscal 1991, with pre-tax earnings of \$1.6 million.

## ***Company Background***

PHOTOTELESIS was founded in September, 1985 to address specific vertical markets with image communications product needs. The company conducted extensive test marketing before selecting the Federal Government sector as the most promising area to develop. After consulting many high-level users within policy-making groups, the company generated product requirements which it felt would address broad needs within selected government departments and agencies.

The products developed from these requirements were announced at a major trade conference in May of 1986, and active marketing began. Initial product shipments commenced in June of 1986.

In the fall of 1986 the company completed development of its business strategy, assembled the executive team, and began work on a business plan to solicit funding for a significant expansion of marketing and manufacturing activities.

---

# EXECUTIVE SUMMARY

---

---

The PHOTOTELEESIS management team brings together broad skills in the management of high technology companies, as well as specific expertise in the development and marketing of image communications and processing systems. The company intends to focus its personnel on the key activities of marketing, product development, and administration, while utilizing outside contractors for manufacturing, certain specialized engineering, contract development and technical publications.

## ***Market Potential***

PHOTOTELEESIS conducted intensive market research in 1986 in selected segments of the Federal Government market, and concluded that a significant opportunity exists for the company's products. Key indicators in forming this conclusion include:

- An identified and unfulfilled need for low cost image communications to support the development of major program-level initiatives in Communications, Command, Control and Intelligence systems (known as C<sup>3</sup>I) for defense-related applications. The current budget calls for expenditures of \$17.4 billion in fiscal 1987 to support major programs.
- The planned deployment of a new generation of secure and mobile communications equipment for the D.O.D. arena, with program-level expenditures on the order of billions of dollars in the next five years.
- The burgeoning market for products designed to government standards for handling classified information, called TEMPEST, presently estimated at \$350 million and expected to double or triple in size by 1990.
- The absence of significant entrenched competition in providing packaged image systems to Department of Defense and related markets.
- The trend toward use of commercial equipment as opposed to high cost procurement of MIL-SPEC components.

The above indicators prompted PHOTOTELEESIS management to test market reaction to its image communications technology and determine the applications, feature requirements and price points necessary for success in the targeted markets.

---

# EXECUTIVE SUMMARY

---

---

These activities resulted in the identification of highly receptive user groups in the following government departments:

- Department of Defense
- Executive Office of the President
- Department of Energy
- Department of Justice
- Department of Treasury
- NASA

PHOTOTELESIS has made revenue shipments of evaluation quantities to target customers during 1986 and has received orders for additional equipment for delivery in 1987. In addition, high-level user groups have been identified in each of the above departments who are prospects for sale in 1987.

### ***Marketing Strategy***

PHOTOTELESIS sells its products directly to major accounts in its target markets through government purchasing contracts, and plans to offer its products on the G.S.A. (General Services Administration) price lists. The company will also develop indirect marketing channels through Prime Contractors, Sales Representatives, and Value Added Resellers who specialize in government electronics marketing.

The company markets "top down" by identifying major program initiatives in high-level policy-making groups, and selling "seed units" to elite users who can set requirements for large volume contracts in the future.

PHOTOTELESIS management believes that rapid deployment of its image communications technology in high-level user groups will lead to the company's products becoming a defacto standard, as new users develop who require compatible technology. This strategy will provide a significant barrier to future competition in the image communications arena.



---

# EXECUTIVE SUMMARY

---

---

## ***Product Line Overview***

The PHOTOTELEISIS products are known as Remote Image Transceivers, or R.I.T.'s. The RIT is based on technology and components purchased on an O.E.M. basis from Image Data Corporation, who markets their product as The Photophone™.

The company has developed three versions of the RIT which are specialized for its target markets:

- Desktop Products**     The company provides desktop RIT's which offer specialized communications options for secure, radio, or cellular operation, and provides an advanced high-resolution camera and shipping cases as standard features. A version of the desktop secure product is being developed for use in classified applications which require special design features and certification by the National Security Agency.
- ATR-RIT Products**     This product is a repackaging of the desktop technology into an industry standard Aircraft Transport Racking (ATR) form factor suitable for mounting in aircraft, marine or mobile environments. The ATR-RIT is offered with both secure and non-secure communications options and may be powered by an optional battery pack or available DC power. The ATR-RIT permits image communications to take place from field locations such as battlefields, airspace or intelligence monitoring sites where conventional packaging techniques would be impractical.
- Briefcase Products**     Test marketing has uncovered a great interest in a portable or "briefcase" version of the RIT for both secure and non-secure applications where portability is a necessity. The packaging technology for the ATR-RIT will be adapted for the briefcase products, yielding a package that will fit inside a standard briefcase form factor, including display, keypad, electronics, battery pack and communications interface. This product will significantly increase the market potential of the RIT technology and push the product into applications in which image communications has not heretofore been available. Target field applications include infantry, disaster recovery, paramedic, construction, surveillance and security.

---

# EXECUTIVE SUMMARY

---

---

---

## ***Financial Overview***

PHOTOTELEESIS anticipates that revenues from its presently identified markets will be in excess of \$13 million over the next three years, with near break-even profitability achieved during 1987 on revenue of \$1.6 million. Pretax profits are planned to grow to \$1.6 million by the end of calendar 1989 on revenues of \$7.2 million. These forecasts assume penetration of presently identified markets only and do not include substantial potential for the company's products in other markets which have been tested.

The company's financial projections assume that the corporation is funded with \$750,000 by the end of May, 1987. The funds will be used to expand marketing and product development activities, and to ramp up volume manufacturing through a subcontractor.

---

Notes

---

---

---

**PHOTOTELEESIS-CONFIDENTIAL**

## ***The Company***

---

# ABOUT THE COMPANY

---

## History

---

### ***Founded***

PHOTOTELESIS was founded in SEPTEMBER 1985 and was chartered as a Texas Corporation in January 1987. The business purpose of the corporation is to address specific vertical markets with customized video transmission products.

### ***Test Marketing***

Specific product concepts were successfully test marketed at policy-making levels within NASA, the Pentagon, and Federal law enforcement agencies. User groups within each market sector were also consulted, and specific product specifications were derived.

### ***Product Announcement***

The first products were announced at the Armed Forces Communication & Electronics Association (AFCEA) 1986 International Conference & Exhibition in Washington, D.C. in May of 1986.

### ***Development***

The first product prototypes, Sec-RIT and ATR-RIT, were completed in January of 1987.

### ***Orders and Shipments***

Shipment of the Com-RIT product to the FBI occurred in June of 1986. Initial orders for Sec-RIT and ATR-RIT were taken in October and November of 1986, respectively.

### ***Organization***

Additional marketing and financial expertise were added when it became apparent the business opportunity was there. In December of 1986, a corporate strategy and business plan were developed.

NOTE: See product literature in this package for more details about specific products.

PHOTOTELESIS-CONFIDENTIAL

---

# ABOUT THE COMPANY

---

## Strategy

---

### ***Our business strategy***

Our business strategy is to take commercially available, "off-the-shelf" products, add our own technology, packaging, and marketing expertise, then sell to our customers. We will make use of contract personnel when appropriate to keep overhead costs down. Here's how it works:

### ***Suppliers***

Suppliers provide us with commercially available products, such as

- Image communication subassemblies
- Video equipment
- PC's and PC peripheral equipment.

### ***PHOTOTELEESIS***

Then we add our own technology and packaging to create our product. And we market these products to our vertical market sector.

### ***Contract Personnel***

We use contract professionals where possible. In particular, this is appropriate for legal work; certain engineering work, technical publications, documentation, advertising, and manufacturing.

As a result, we can produce specialized products from off-the-shelf products at very competitive prices. We offer these products through a variety of distribution channels. By using contractors where possible for our needs, we greatly reduce overhead costs.

**PHOTOTELEESIS-CONFIDENTIAL**

# ABOUT THE COMPANY

## Strategy Illustration

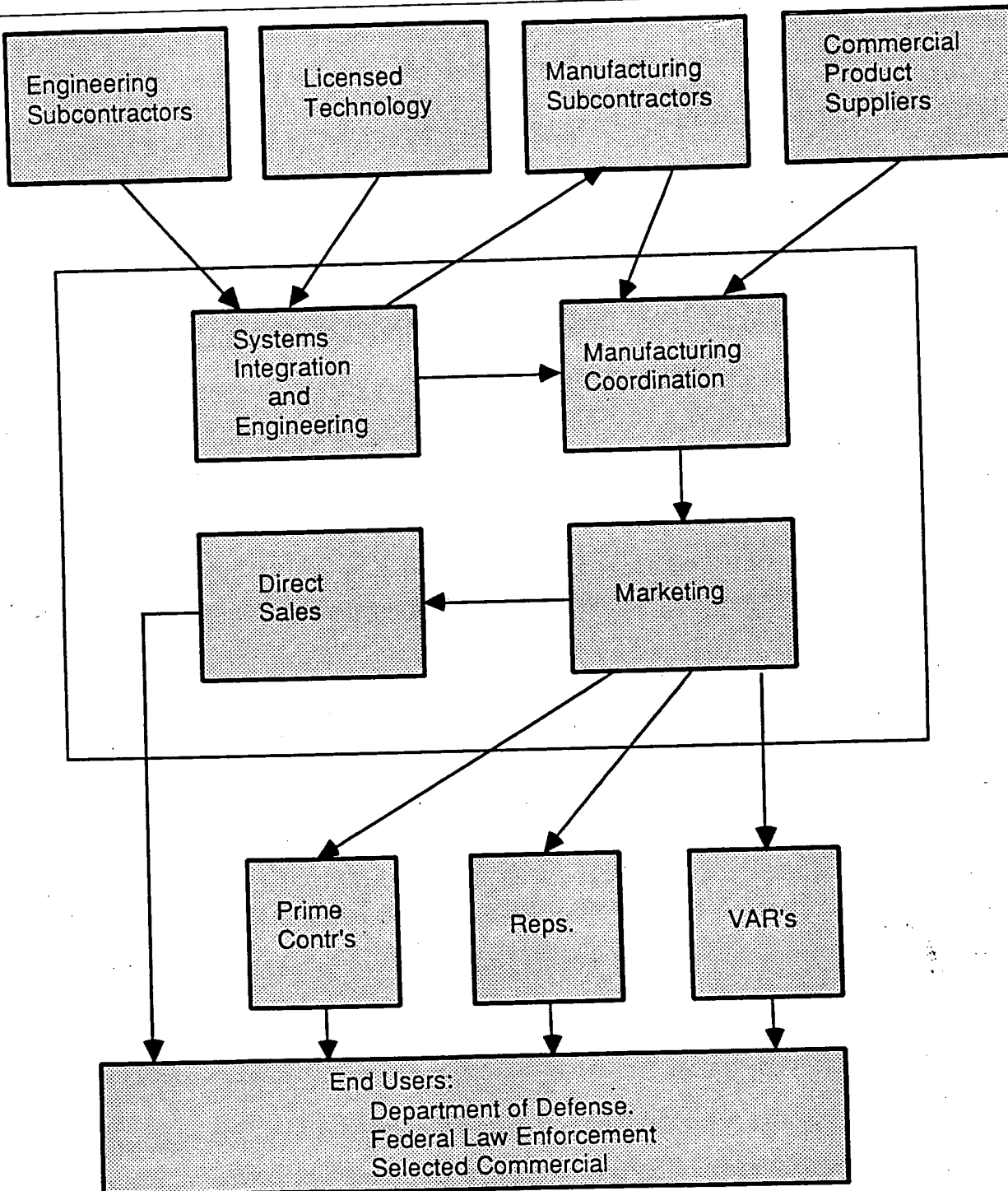

PHOTOTELESIS-CONFIDENTIAL

---

# ABOUT THE COMPANY

---

## Organization

---

### ***Present Organization***

Presently our staff includes:

- David Monroe, President
- Larry Glidewell, Marketing and Sales
- George Leonard, Marketing and Sales
- Mike Huffman, Finance and Administration
- Eric Schweppe, Engineering

### ***Planned Expansion***

During 1987, we plan to add these staff functions:

- Hardware Engineer
- Software Engineer
- Secretary
- Clerk

### ***External Functions***

These functions will be handled by contract personnel:

- Manufacturing
- Government Contract Development
- Customer Service
- Accounting and Legal
- Technical Publications and Documentation
- Engineering Services

**PHOTOTELEESIS-CONFIDENTIAL**



---

# ABOUT THE COMPANY

---

## Organization Chart

---

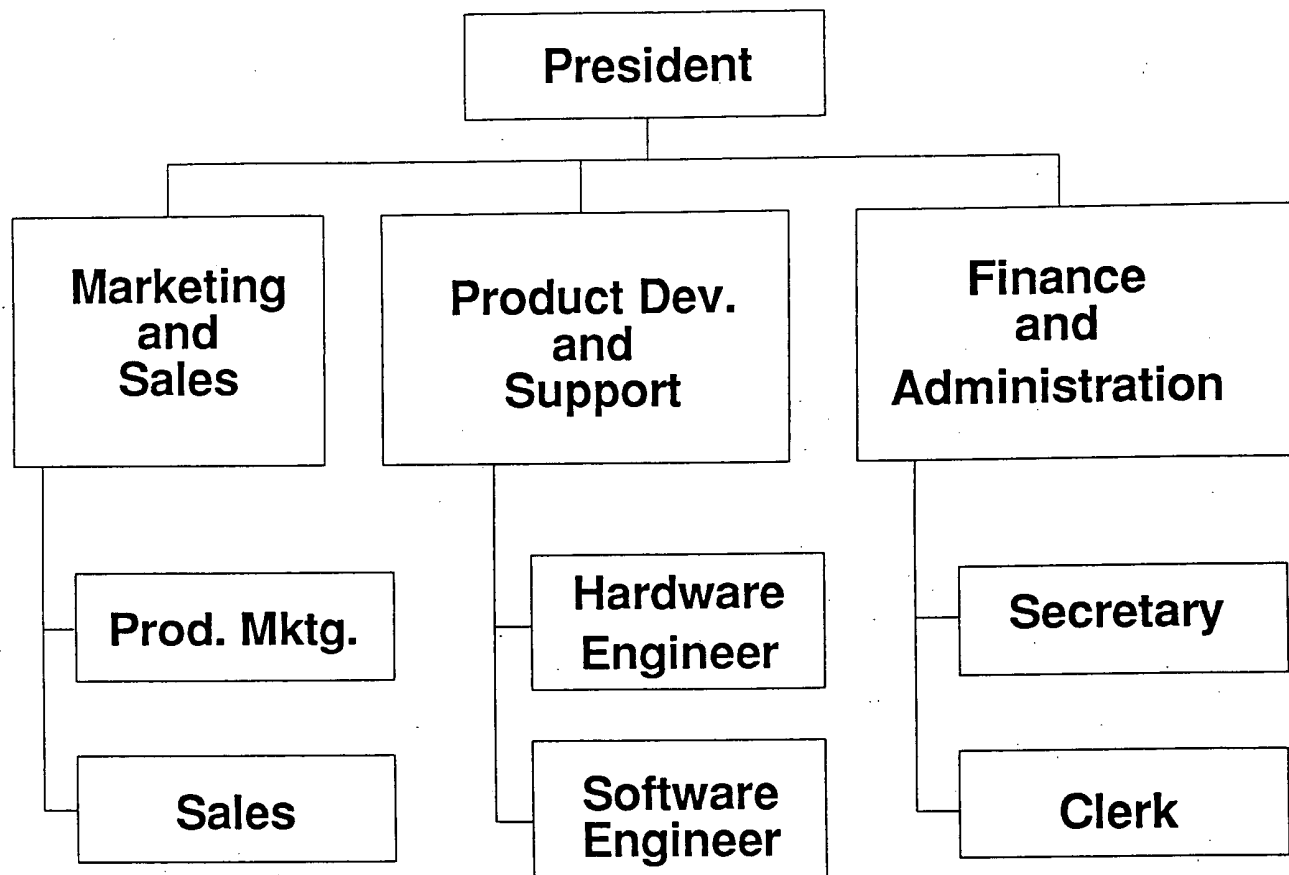

PHOTOTELEESIS-CONFIDENTIAL

---

# ABOUT THE COMPANY

---

## Management Profiles

---

The PHOTOTELEESIS executive team contains the key strengths in management, finance, engineering and marketing that are required for success in the high technology systems field. This section presents brief profiles of each individual on the team.

### **David A. Monroe**

David Monroe, 34, has worked as an engineer and scientist throughout his career, from individual contributor positions progressing to President and Founder of PHOTOTELEESIS Corporation.

Prior to starting PHOTOTELEESIS, Mr. Monroe was Vice President and Co-Founder of Image Data Corporation, where he developed the PHOTOPHONE video telephone product from concept through manufacturing startup and product introduction.

Mr. Monroe was previously Vice President of Office Graphics Systems of Datapoint Corporation, where he was responsible for the management of several of Datapoint's most complex development programs, including the company's Laser Printer, Color Graphics System, Impact Printers and Facsimile products. Prior to Datapoint, Mr. Monroe was Principal Engineer with Mnemonics, Inc., a San Antonio and Sunnyvale-based startup in the field of solid state memory systems.

As President, Mr. Monroe brings vital skills in management of high-technology startups, including research and development, product and market strategy, and general management of electronics and computer products companies.

Mr. Monroe's educational background includes Undergraduate curricula in Physics and Computer Science, University of Kansas, 1970-1973, Wharton Short Course on Finance, 1979, and AMA Management Course, 1980.

---

# ABOUT THE COMPANY

---

## Management Profiles

---

### **Larry P. Glidewell**

Mr. Glidewell, 35, has a varied professional background in communications, organizational development, training, and marketing. Mr. Glidewell created the marketing function at PHOTOTELESIS to conduct the market research and test marketing required to define the business opportunities for the company's technology.

Prior to PHOTOTELESIS, Mr. Glidewell was a partner in Interactive Video Solutions in San Antonio, where he developed the marketing opportunity for computer controlled laser videodisc technology in the military and government markets. Mr. Glidewell previously was Founder and President of MAP Development in Houston, which was a pioneer in the use of interactive video and computer aided instruction for the oil and gas industry. Prior to this, Mr. Glidewell held management positions at NL Industries and Modern Management Methods in industrial and business training and development.

Mr. Glidewell's background provides the company with key strengths in management, business and marketing, as well as specific expertise in the application of high technology videodisk and teleconferencing systems in business.

Mr. Glidewell's educational background includes a B.S. in Communication, 1973, and an M.A. in Organizational Development, 1975, both from Oklahoma State University.

---

# ABOUT THE COMPANY

---

## Management Profiles

---

---

### **Michael L. Huffman**

Mr. Huffman, 37, has an extensive background in finance, accounting, administration, and planning. Mr. Huffman joined PHOTOTELESIS to assume the management of the financial and administrative operations for the company.

Prior to this, he was Director of Finance and Administration for Network Standards Corporation in San Antonio, where he managed all financial, accounting and administrative operations for the company. Previously, Mr. Huffman held management positions in finance and administration at Datapoint Corporation, where he was actively involved in both marketing and product development functions. Prior to this, he held positions in financial analysis and business development with Duncan Smith Co. and Electronic Data Systems.

Mr. Huffman brings excellent credentials and experience to the company in the management of finance, accounting and planning functions, with specific expertise in high technology businesses.

Mr. Huffman's educational background includes a Bachelor of Arts and a Bachelor of Science in Civil Engineering from Bucknell University, 1972, and an MBA in Finance and Management from the University of Texas, 1978.

---

# ABOUT THE COMPANY

---

## Management Profiles

---

### **George L. Leonard**

Mr. Leonard, 37, has a varied background in high technology electronic systems that includes product development, product management, marketing and sales. He joined PHOTOTELESIS to provide additional emphasis in the marketing and sales of the company's products.

Prior to joining the company, Mr. Leonard was Director of Marketing and Sales, Advanced Products Division, for Datapoint Corporation, where he managed the market research, introduction and marketing activities for a new generation of desktop networked video conferencing equipment. Previously, Mr. Leonard held various management positions in product marketing, product development and planning for Datapoint's office automation product line. Prior to this, Mr. Leonard was engaged in product development and engineering management at Basic Four Corporation, Panhandle Eastern Pipeline, and GeoSource International.

Mr. Leonard brings key skills to the company in sales, marketing, and product management, with specific expertise in the field of desktop video conferencing.

Mr. Leonard's educational background includes a Bachelor of Science, Electrical Engineering, 1972, and a Master of Electrical Engineering, 1973, both from Rice University.

---

# Notes

---

---

---

**PHOTOTELEESIS-CONFIDENTIAL**

## ***The Market***

---

# THE MARKET

---

## Background

---

### ***Initial Marketing Contacts***

In the fall of 1985 PHOTOTELESIS became interested in the possible application of video telephone technology in the Department of Defense. Through an association with General Doyle Larson, USAF (Ret.), introductions were made to Donald Latham, Assistant Secretary of Defense, Communication, Command, Control, and Intelligence.

After an initial briefing on the product in Washington, Mr. Latham was sufficiently impressed with the product that he arranged a briefing with General Rice, Chief of Joint Special Operations Command, and General Perroots, Director of the Defense Intelligence Agency, and their staffs, to introduce them to the image transmission capabilities that PHOTOTELESIS had to offer. This meeting, although scheduled for only twenty minutes, lasted for two and a half hours.

### ***What We Learned***

The need for image transmission was well known at the policy levels represented in the briefings, and there was significant interest expressed for products which could provide this need. Mr. Latham was a strong proponent for the military buying and, if necessary, modifying existing commercial equipment rather than incurring the time and expense of developing specifications for bid with large companies that specialize in custom government products. Our product not only fit his model of acquisition and cooperation with the corporate sector, but also fulfilled a need within the C3I (Communication, Command, Control, and Intelligence) community, which is involved in communications across all branches of the military.

We learned that several changes to the standard desktop product would be necessary for widespread use within the C3I arena. First, the unit would have to be made compatible with standard encryption devices (known as COMSEC, for Secure Communications), already in use in the military. Second, the product would have to be modified to meet a government standard known as TEMPEST, in order to permit it to handle classified information in a manner that could not be detected electronically by enemy groups.

We also presented a prototype of a portable image transceiver which fit in a briefcase. There was a great deal of interest in this product for use in the field where small size, battery power and radio or satellite communications is required.

**PHOTOTELESIS-CONFIDENTIAL**



---

# THE MARKET

---

## Background

---

---

### **Results**

Based on the positive reception to our product concept, we were given points of contact within specific user groups and encouraged to discuss our capabilities and their requirements for image transmission products. We concluded that discussions and demonstrations with these groups would allow us to test whether there was indeed a market opportunity for our products.

**PHOTOTELEESIS-CONFIDENTIAL**

---

# THE MARKET

---

## Test Marketing

---

### ***Objectives***

The enthusiastic reception to our products in the C3I market convinced us that a project should be initiated to test the overall market firsthand. The use of image transmission technology in this market was so new that there was no market research data readily available, but we determined that collecting primary market data from potential users would be even more valuable. The objectives of the market test were to determine

- the user needs and potential volume for image transmission products
- how the government would go about purchasing the products
- what competitive products might already exist
- what features and pricing would be required

### ***Initial Product Demonstrations***

Initial user groups that were contacted within the C3I community included the National Security Agency, Joint Chiefs of Staff, Special Operations Command Atlantic (SOCLANT), FBI, NASA, Secret Service, White House Communications, Defense Communications Agency, Defense Intelligence Agency, and groups from the Department of the Army. We held additional briefings in Washington with Army Intelligence, Drug Enforcement Administration, U.S. Postal Investigation Service, Voice of America, Joint Special Operations Agency, and Army Psychological Operations.

The information that was collected from presenting the product to these user groups confirmed that there was a substantial market opportunity for off-the-shelf image transmission equipment. The requirements for COMSEC compatibility and TEMPEST certification were also validated by these groups. We also collected additional information on the need for units that could operate in mobile or portable applications, communicating imagery back to a central "base station" Many groups indicated that the product concept and price range was superior to other imaging products available to the government, and that in fact there was no incumbent product in widespread use.

---

# THE MARKET

---

## Test Marketing

---

### ***Placement of First Units***

The test marketing activities led directly to purchases of initial units from the FBI and Army groups located at Ft. Eustis and Ft. Belvoir. Ft. Bragg SOCLANT, who provided valuable information in defining product features and assistance in compatibility testing, took delivery of the first two prototype encryption-compatible units, which would later become the Sec-RIT. The FBI purchased two units for evaluation, including the first delivery of a unit later called the Com-RIT that could transmit images from a vehicle over cellular telephone. An Army group awarded us a contract for a unit that could be mounted on an aircraft and transmit images over satellite-based secure voice equipment to a distant command center.

### ***Conclusions - the Opportunity***

Several conclusions were evident from the market test. First, there appeared to be a substantial immediate market opportunity in the groups that were sampled for a relatively low-cost, off the shelf image transceiver. Although the purpose of our test marketing was to gather information, we received orders in addition. There did not appear to be substantial entrenched competition for encryption-compatible image transceivers that could operate over existing voice communications facilities. Although more market data was needed to properly measure the total opportunity, there was enough primary data available from talking to prospects and initial customers to justify moving ahead with a major product announcement.

### ***Conclusions - Product Requirements***

Second, specific product modifications in the packaging and communications areas were mandatory to allow interested groups to use even evaluation quantities of units. We concluded that three product families would be required:

- desktop units, for command centers and other stationary installations
- mobile units, for use in vehicle, aircraft or marine platforms
- portable units, for personal use anywhere in the field

Each of these families had to operate over existing secure voice communications systems, and at least the desktop units would have to meet TEMPEST standards to address the broad market. We also saw needs for networking these products together, to allow for multi-site briefings or access to remote image databases.

**PHOTOTELEESIS-CONFIDENTIAL**

---

# THE MARKET

---

## Test Marketing

---

We concluded that this product line could meet broad-based needs in defense or federal law enforcement markets, where, combined with existing communications, complete image networks could be constructed. This concept is illustrated in the accompanying diagram.

### ***Conclusions - Applications***

Many of the applications that we found for our products are in the intelligence community for use by analysts who deal with image-based information on a daily basis. While the specific applications of our users are classified, some of the areas of use include :

- real-time collection and dissemination of reconnaissance imagery from video or radar-based sources
- remote access to documents, drawings, maps, or technical illustrations
- multi-site briefings with graphic support
- communication of images from stationary imaging systems to remote sites
- remote access to image archives for personnel identification, medical records, or intelligence files
- real-time visual access for remote expert consultation and problem solving

### ***Conclusions - Marketing***

We discovered that the user community that was interested in our products was tightly knit because of common requirements, so that initial success in one group could spread by word of mouth to other groups with similar needs. *As a result, it looked like a small but highly focused marketing effort could be highly productive.*

We also discovered that interoperability, a term for the ability of different communications or computer equipment to work together, is a key factor for market success. Because of the different custom imaging systems we found installed, there is no widespread interoperability in place between groups. *We concluded that marketing*

---

# THE MARKET

---

## Test Marketing

---

This diagram illustrates our products in a typical customer application.

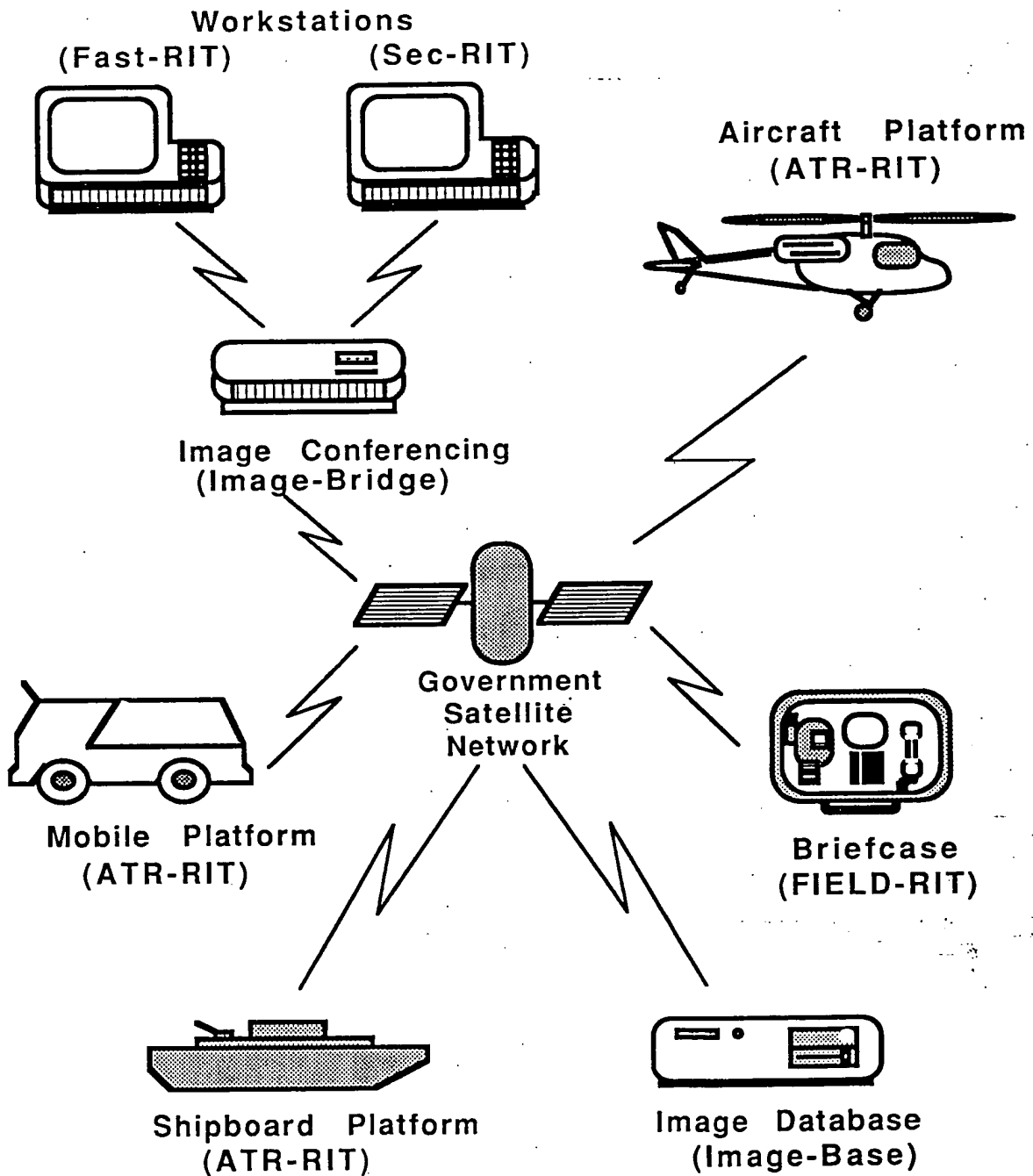

---

# THE MARKET

---

## Test Marketing

---

*success with one group could lead to requirements for new groups to have compatible equipment.*

*We also concluded that our marketing success depended on working through a triangular relationship of policy makers, user groups, and contracting officers or acquisition groups. Understanding the overall direction of government programs and gaining the support of the policy makers allows us to select key user groups to address. Placing evaluation, or "seed" units in these groups gains us influence in the development of specifications for future volume contracts. Finally, working through the acquisition groups to win major contracts for our products can create substantial barriers to future competition.*

In short, we had found a market niche that had immediate requirements, had funds available to spend, and could be successfully penetrated by a small, aggressive company that could be more responsive to user needs than the established government contractors.

During the test marketing project we demonstrated our products to over thirty user groups who have an application which they are interested in pursuing. These groups form the basis for our 1987 forecast, which is detailed in the Marketing section that follows.

### ***Announcement***

In May of 1986, PHOTOTELESIS announced the Sec-RIT and Com-RIT product lines, as well as future directions in portable and TEMPEST qualified units. The products were announced at a major military trade show known as AFCEA (Armed Forces Communications and Electronics Association). There was strong user interest at the show, resulting in over fifty qualified leads for future business. Press releases were published in magazines targeted at both defense and communications audiences which have to date resulted in over 250 leads for Com-RIT and Sec-RIT products. Copies of our press releases may be found in the Appendix.

---

# THE MARKET

---

## Market Statistics

---

### ***Introduction***

During the test marketing campaign, we concluded that additional data should be gathered on the size of the markets we were interested in, and on major policy directions in the Department of Defense that were influencing the market and might be advantageous to us in the future. Since no research reports on image communications equipment in the military was readily available to us, we began to collect statistics through a variety of sources, including books, articles, newspaper stories and personal interviews with highly placed individuals in the military.

Our primary focus remained the C3I market: Command, Control, Communications and Intelligence. Within that umbrella term for all D.O.D. communications programs, we identified three major government programs that were relevant to our market thrust:

- TEMPEST qualified products
- STU-III Secure Telephone Units
- Mobile Subscriber Equipment

Each of these programs is described on the following pages, including forecasts of future market opportunity. Then we will draw conclusions about their importance to our marketing direction.

---

# THE MARKET

---

## Market Statistics

---

### ***Command, Control, Communications and Intelligence (C3I)***

Programs that involve D.O.D secure communications in all branches of the Military are grouped into this classification for administrative control. The Assistant Secretary for C3I reports to the Secretary of Defense, and oversees all policies and budgets regarding agencies, programs, and acquisitions of equipment.

Deployment is accomplished through the Joint Chiefs of Staff to all Military service Command, Control, Communications and Intelligence branches through their world-wide organizational structure composed of CINC's (Commanders in Chief) representing regional and strategic commands. Departments of Army, Navy, Air Force, and Marines may have individual programs, but C3I seeks to ensure inter-service and NATO compatibility.

The growth of budgets for C3I programs provides a broad market opportunity for adding our secure image communications products to D.O.D secure communications systems.

**FY '86 C3I Budgets (\$14.298)**



**FY '87 C3I Budgets (\$17.406)**

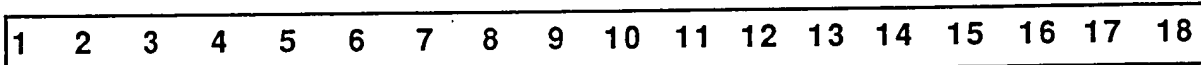

***Billions of Dollars***

Source: C3I Handbook, P. 262, Defense Electronics, 1986.



---

# THE MARKET

---

## Market Statistics

---

### **TEMPEST**

TEMPEST is the Federal government's word for the countermeasures taken on electronic and data processing equipment to prevent them from emitting electronic signals that can be detected by unauthorized persons. TEMPEST requirements are quite common in the Federal government, thus creating an opportunity for TEMPEST qualified image transmission systems.

TEMPEST equipment is required in many office environments in the U.S. Federal government which deal with classified information, and for almost all non-tactical applications outside the U.S. TEMPEST-qualified products command a high price premium in the market compared to comparable commercial versions.

"Government and industry officials are forecasting a steady demand for TEMPEST equipment and services over the next five to ten years.

Current expenditures are \$350 million, a number that might easily double or triple by the end of the decade."

We will provide TEMPEST-compatible desktop and portable Remote Image Transceivers to take advantage of the tremendous growth in this market area.

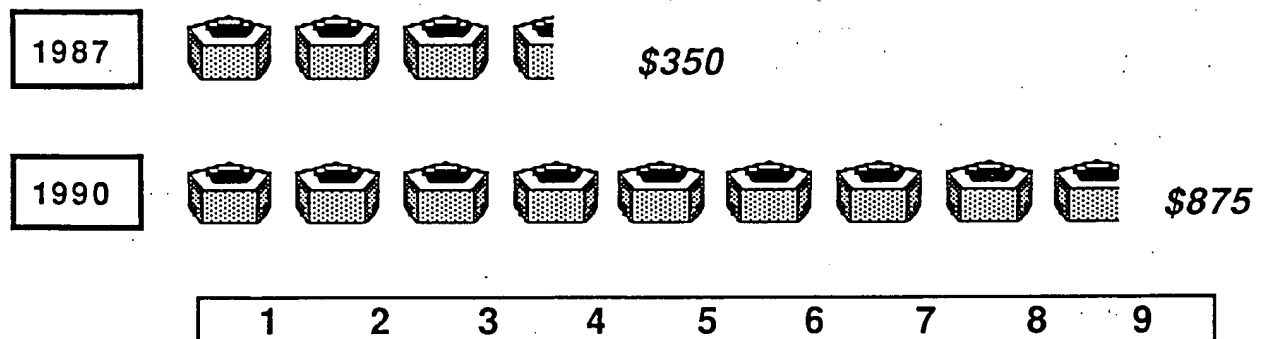

*Millions of Dollars*

Source: C3I Handbook, Pp 181-200, Defense Electronics, 1986.

---

# THE MARKET

---

## Market Statistics

---

### **Secure Telephone Units**

STU-III is the acronym for the third-generation Secure Telephone Unit program. This program extends to all Federal agencies and contractors, creating a tremendous market opportunity for encryption-compatible desktop image transceivers.

Special Secure Telephone Units (STU's) are being developed and produced under a National Security Agency sponsored program. Initial contracts let in 1986 worth \$190 million will allow the secure telephone market to expand from the current STU-II's to up to 50,000 new STU-III's. Ten thousand units will be produced per month and will sell for around \$2000. Initial contracts were let to RCA (\$84.7M), AT&T (\$55.2M) and Motorola (\$50.1M). Industry estimates forecast a market size of \$500 million by 1990, resulting in an installed base of up to 500,000 units over the next ten years.

Our Sec-RIT product is designed for compatibility with STU-III, opening a vast new market for us as these telephone systems come into use. ***For example, if five percent of the expected STU-III desktops are candidates for image transmission, that represents a total available market of 25,000 units over the next ten years.***

### **Contracts in Place and Future Growth**

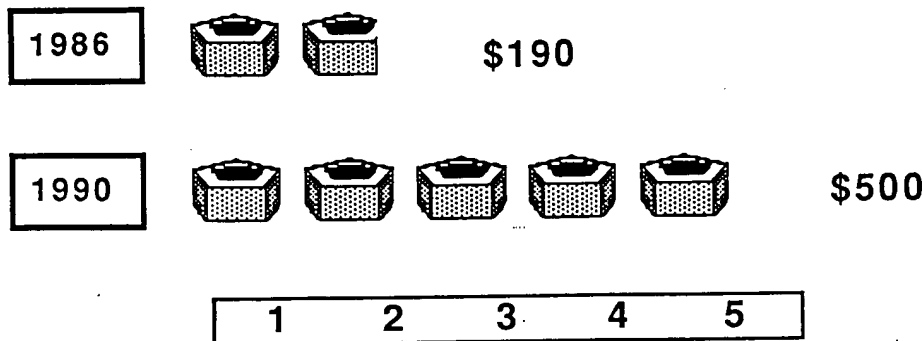

**Millions of Dollars**

Source: The New York Times, Tuesday, July 8, 1986  
Defense Electronics, March, 1987.

---

# THE MARKET

---

## Market Statistics

---

### **Mobile Subscriber Equipment**

The Mobile Subscriber Equipment (MSE) program is a new U.S. Army program which provides vehicular and man-portable communications equipment.

The largest procurement of tactical communications equipment in history, MSE is often described as "the Army's Cellular System". With initial operation scheduled for 1988, the program will provide a worldwide secure switched network for voice, data, teletype, and facsimile communications for digital radio telephone users, switched system subscribers, information processing facilities, and combat-net radio users. This program is slated for expenditures of \$1.0 billion in Fiscal 1988 and \$995 million in Fiscal 1989. Total program expenditures are expected to top \$4.5 billion.

Our ATR-RIT and briefcase product families will be compatible with these new cellular systems. *If the market for image transmission is only one percent the size of the total MSE market, it represents a \$10 million opportunity for us in 1988 alone.*

### **MSE Program Expenditures**

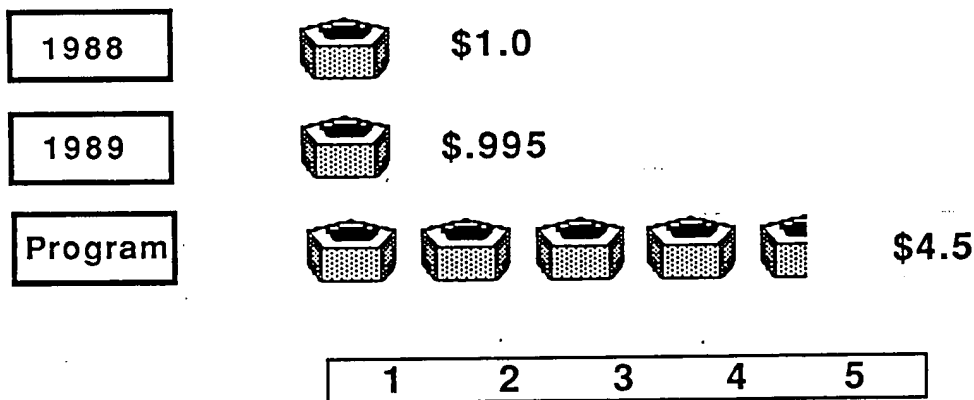

*Billions of Dollars*

Source: C3I Handbook, P.119, Defense Electronics, 1986; Microwave Journal, February 1987.

---

# THE MARKET

---

## Market Statistics

---

### **Conclusions**

Our investigation into these major programs has yielded several important conclusions:

**First**, the overall C3I market is receiving major funding for communications equipment and is projected to have strong future growth. We have developed direct contacts to policy makers in this arena who are enthusiastic supporters for our products. Moreover, C3I has the organizational focus across all branches to allow us to market our products using a top-down approach without needing a large direct sales force.

**Second**, the market for TEMPEST equipment is growing at a rapid pace and is projected to continue to do so over the next five to ten years. This indicates a ready market for TEMPEST-compatible versions of our products, important because the broad market opportunities for us are in applications which demand TEMPEST certification.

**Third**, the STU-III market indicates a major shift in thinking about COMSEC, or Secure Communications, in the Federal Government, from a few expensive units in limited locations to a broad deployment across all branches of the government that deal in classified information. Since these units are just now beginning to appear in the market and are being manufactured in very large quantities, we are well positioned with our COMSEC and future TEMPEST-compatible product line on the leading edge of an important new market.

**Fourth**, the projected growth in the Mobile Subscriber Equipment market points to a vastly increased emphasis on world-wide military communications in the field. We are well positioned to take advantage of this new market with our secure mobile and portable products.

**Taken in total, we have concluded that these programs point to a major market being formed for products which are compatible with the new generation of secure communications equipment.** Our research points to strong growth in this market over the next five years, creating a total available market measured in the billions of dollars, and tens of thousands of "sockets" into which we can plug our products. We have already made significant strides in developing compatible products for this market and have focused our marketing resources on tracking and penetrating major contract opportunities for our image-based product line.

---

# Notes

---

---

---

---

# ***Competition***

---

# COMPETITION

---

## Products

---

### ***Introduction***

A key factor in assessing the market opportunity for the PHOTOTELESIS product line is the presence of competition, particularly in the areas of image transmission systems that offer COMSEC compatibility, can operate over existing voice communications facilities, and are offered in TEMPEST versions. One of our best sources of competitive information is our own customers, who have consistently told us that our product concept is unique in the market.

We realize, however, that there are many communications products and systems in the federal government that are competing for contract dollars, even though they may cover a wide diversity of features and price points. This section takes a look at the competitive environment that currently exists and draws several conclusions that influence our marketing strategy.

### ***Video Conferencing Products***

Currently, video transmission in the Federal arena is primarily confined to full-motion (i.e. closed circuit television) systems. These systems are installed in expensive, custom conference rooms for use between high-level management groups. The cost per room is usually in the range of \$100-250 thousand, and the cost per hour of use ranges from \$250-750. Communications lines which can handle the high speed video information between rooms are highly specialized and in short supply. Although some of these rooms operate over encrypted circuits, security remains a significant problem. Some rooms utilize lower-cost freeze-frame equipment which can send still pictures over standard telephone lines, but the equipment is customized for each installation and, like the full-motion systems, complex to operate.

### ***Tactical Imaging Requirements***

Many groups within the Federal government deal with image-based information on a routine basis. Military and law enforcement groups who collect images in the field often record the images on video tape, which must then be delivered by courier. Alternately, they use conventional camera technology, which must be developed and printed before the images can be couriered to their destination or sent by facsimile.

The advantages of video transmission are that any image, whether it be a document, object, person, or scene, can be captured instantly from any video camera source. Once captured, the image, now in digital form, is compressed and sent over a standard voice-grade communications circuit.

---

# COMPETITION

---

## Products

---

Key factors in applying this technology are:

- the resolution, or clarity, of the image received, including documents, objects, persons, or scenes
- the speed at which an image can be transmitted
- the ability of the transmission device to achieve error-free communication
- the ability to use all types of voice communications circuits, including telephone, radio, and satellite, in both secure and non-secure modes
- the ability to operate the device in fixed, mobile and portable environments
- the ability to transmit classified information without risk of electronic detection
- ease of use to minimize training time
- low cost to acquire and operate
- reliability
- off-the-shelf availability

### ***Freeze-Frame Video Transmission Systems***

There are two principal vendors providing commercial video image transmission systems to the Federal Government: Interrand Corporation and Colorado Video. There are also two main vendors providing military equipment: Dalmo-Victor (division of Singer), and E-Systems. Detailed comparisons of these products against the PHOTOTELESIS products are presented in tabular form at the end of this section. A few salient points are worth noting here:

- The commercial products, which have been used mainly in conference room applications, are not known to have government-supplied encryption interface capabilities, operate only on standard telephone circuits, are not offered in TEMPEST form, and are not available in versions which can be used in mobile or portable applications.



---

# COMPETITION

---

## Products

---

- The military products are very expensive, not available off-the-shelf, do not operate in a network which permits multi-point briefings or remote image database retrieval, are difficult to use, and are not offered in compatible desktop versions.

In short, although some competitive features are offered by each product, no one product meets all the required characteristics defined above.

### ***Facsimile Products***

Facsimile technology provides a way to electronically scan flat images, such as documents or photographs, and send them over ordinary telephone lines. Facsimile technology is capable of high resolution, or image clarity, for black and white images, but suffers in comparison to video techniques where the image has many intermediate levels of gray, such as images of objects, people, or scenes. Facsimile devices attempt to accommodate for this deficiency by using a technique called *half-toning*, which uses closely spaced patterns of black and white dots to simulate shades of gray.

Two military facsimile devices currently in use are the Tactical Field Fax, available from various manufacturers under D.O.D. contract, and the MDFT, manufactured under federal contract by Video Masters. These devices are compared to the PHOTOTELESIS products in a table at the end of this section. The main conclusions of this comparison are as follows:

- Facsimile devices are the preferred alternative for the transmission of documents only, where their high resolution and low cost are significant advantages.
- Facsimile is poorly suited to other kinds of imagery, since the image must first be captured and printed by some other means before it can be fed into the facsimile scanner, a time-consuming process which also degrades the image. Facsimile transfer does not faithfully reproduce the shades of gray in an image, which is vital in many tactical applications including personnel identification, reconnaissance imagery, etc. Therefore, video techniques will be preferred when one device must be usable with a variety of image sources.
- Facsimile protocols are sensitive to communications line quality; "drop-outs" on the line can cause portions of the image to be destroyed, necessitating resending the entire image. The PHOTOTELESIS products use a coding technique known as forward error correction for error-free transmission over a wide range of line quality.

---

# COMPETITION

---

## Products

---

### *Desktop Products*

| Feature               | PHOTOTELEESIS                                  | INTERRAND   | COLORADO VID.   |
|-----------------------|--|---|-----------------|
| Resolution (pixels)   | 592x440x128                                    | 640X480X256   | 512x480x256     |
| Speed (seconds)       | 10-40  | 10 for partial resolution<br>80 for full resolution | 25              |
| Error Correction      | block transmission<br>forward error correction | error checked                                       | no              |
| Transmission          | telephone, radio,<br>cellular, satellite       | telephone   | telephone       |
| Encryption Compatible | yes, programmable                              | unknown   | unknown         |
| Packaging             | desktop, mobile,<br>portable                   | desktop or console                                  | rack mount      |
| Ease of Use           | menu based, helps                              | manual controls                                     | manual controls |
| Cost                  | \$10,000-24,500                                | \$11,000-75,000                                     | \$15,000 est.   |
| Availability          | off-the-shelf                                  | off-the-shelf                                       | off-the-shelf   |

*Note: Data sheets are included in the Appendices.*

---

# COMPETITION

---

## Products

---

### *Military Products*

| Feature                  | PHOTOTELEESIS                                  | DALMO-VICTOR     | E-SYSTEMS        |
|--------------------------|--|------------------|------------------|
| Resolution<br>(pixels)   | 592x440x128                                    | 256x256X256      | 512X480X256      |
| Speed<br>(seconds)       | 10-40  | 3-180            | 120              |
| Error Correction         | block transmission<br>forward error correction | yes              | none specified   |
| Transmission             | telephone, radio,<br>cellular, satellite       | radio, satellite | radio, satellite |
| Encryption<br>Compatible | yes, programmable                              | yes              | yes              |
| Packaging                | desktop, mobile,<br>portable                   | mobile           | two man portable |
| Ease of Use              | menu, help screens                             | manual controls  | manual controls  |
| Cost                     | \$18,500-24,500                                | \$50-100,000     | unknown          |
| Availability             | off-the-shelf                                  | special order    | unknown          |

*Note: Data sheets are included in the Appendices.*

# COMPETITION

## Products

### *Facsimile Products*

| Feature               | PHOTOTELEESIS                                  | FIELD FAX         | MDFT                  |
|-----------------------|--|-------------------|-----------------------|
| Resolution (pixels)   | 592x440 per image                              | 204x19per inch    | 75-300 per inch       |
| Gray Scale            | 128 levels                                     | 4-16 levels       | 5-33 levels           |
| Input Medium          | high res. camera                               | flat scanner      | flat scanner          |
| Speed (seconds)       | 10-40  | 7-15              | 15                    |
| Error Correction      | block transmission<br>forward error correction | none              | none                  |
| Transmission          | telephone, radio,<br>cellular, satellite       | radio, satellite  | radio, satellite      |
| Encryption Compatible | yes, programmable                              | yes               | yes                   |
| Packaging             | desktop, mobile,<br>portable                   | rack mount, 110v. | two suitcase portable |
| Ease of Use           | menu, help screens                             | manual controls   | manual controls       |
| Cost                  | \$18,500-24,500                                | \$7800-16,800     | unknown               |
| Availability          | off-the-shelf                                  | D.O.D. contract   | unknown               |

*Note: Data Sheets are included in the Appendices.*

---

# COMPETITION

---

## Conclusions

---

We have drawn several conclusions from our analysis of the competition:

**First**, the PHOTOTELEESIS approach to image transmission is clearly different and superior to other solutions on the market. We believe that we uniquely meet all the requirements for success stated earlier:

- we offer high resolution combined with full gray-scale capability that gives excellent image clarity with a variety of subject material
- our transmission protocols achieve error-free communication even with marginal communications channel quality
- we can send a typical image over encrypted circuits in 20-30 seconds, and over standard telephone lines in under 10 seconds
- we use a wide variety of voice communications circuits and encryption devices
- we can operate in fixed, mobile and portable environments
- our TEMPEST version will permit us to transmit classified information without risk of electronic detection
- we offer ease of use through simplified control panels and menu-based operation
- our products are low cost to acquire and operate
- our design has proven reliability
- we offer off-the-shelf availability

**Second**, although there are different, incompatible products available which meet some of the needs above, our product line meets them all in one family of interoperable products.

---

# COMPETITION

---

## Conclusions

---

**Third**, we believe that we can minimize competitive threats from other companies with substantially greater resources than ours by

- offering products which are tailored to meet specific user needs by providing compatibility with a wide range of communications systems and encryption devices
- offering a range of compatible product solutions which can work together
- providing products at attractive price points
- concentrating on penetrating key applications early and establishing our products as the standard, thus locking out competition with incompatible communications protocols

---

# Notes

---

---

---

---

**PHOTOTELEESIS-CONFIDENTIAL**

# ***Marketing***



---

# MARKETING

---

## Sales Process

---

### ***Customer Model***

We view our customers and prospects in groups which may be represented as a market pyramid. In an emerging market, penetration occurs at the top of the pyramid where there are a limited number of innovative groups who are eager to purchase state-of-the-art technology. Moving down the pyramid we find larger groups of users, but they are more risk-averse and depend on a more established market before they will commit to purchase. Relating this model to our own customers, we see the market pyramid in four broad groupings:

#### **Advocates**

Product advocates are willing to take standard products for Test & Evaluation, then upgrade to meet full requirements. Purchase volumes: 2 units per order.

#### **Early initiators**

These users must have encryption-compatible units, but do not need to meet all feature requirements initially. Their applications are limited to CONUS (Continental U.S.) operations, since TEMPEST qualification is required for most work off-shore. Purchase volumes: 2-6 units per order

#### **Test bed users**

These groups must prove their products through their own testing and evaluation. Then they will use them in a "test bed" or representative tactical application. They will do their own TEMPEST testing if required. Purchase volumes: 6-30 units per order.

#### **Large groups with established requirements**

Volume orders (30-500 units) over a period of time on open contract, through GSA schedule, or in conjunction with a large contract for other equipment. Many applications will require full TEMPEST certification. Contracts are usually associated with a major program, e.g. STU III, MSE etc.

---

# MARKETING

---

## Sales Process

---

### ***The Role of Product Advocates***

The product advocates mentioned at the top of the market pyramid are extremely important to us as we penetrate new application areas for our products. These users are well known for their expertise in communications and have sufficient "clout" to purchase test and evaluation units. They make their reputation by being the first to use a product in a new area, and are eager to participate in product demonstrations to other user groups. They become "inside salesmen" for the product and are invaluable in establishing early successes. We have developed such champions in each of the initial user groups we have sold into and view their role as an important element of our marketing strategy.

### ***Sales Process***

We have found that successful sales of our products follow this pattern:

- We identify a potential user group through referrals from policy makers or other user groups. They might be identified by their function within a service group or their association with a major communications program.
- Our customers must meet the following qualifications:
  - funds presently budgeted for imaging systems, either on a line-item or discretionary basis
  - defined requirements in place which either fit our products or can be influenced
  - a high priority assigned to the project
  - active involvement of a contracting officer or acquisition group
  - a visible product advocate
- After initial contact by telephone, and assuming the group meets our qualification criteria, we send out a letter and documentation package tailored to their application.
- A follow-up call after the literature is delivered tests interest and identifies specific applications and requirements. A demonstration and briefing is arranged, at headquarters or the customer site.
- The demonstration briefing is held, with participation from key decision makers and their staff. The demonstration is tailored to their applications. We ask for an order for test and evaluation (T&E) units.
- Based on immediate funds availability, the T&E units are purchased and used internally to evaluate the group's broader requirements.

---

# MARKETING

---

## Sales Process

---

- Based on use of the T&E units, the user groups develop written requirements and assign a contracting officer to develop the contract. Key issues involving contract type, price, quantity, contract options for future purchases, and options for other groups to purchase from the same contract are negotiated. More information about contract development is contained in a later section.

Our strategy is to use the above process as a model for our direct marketing activities, tracking the progress of each account through the steps outlined above. In this way we plan to minimize unproductive use of our marketing resources and maximize our focus on accounts that can be developed into volume contracts for our products.

---

# MARKETING

---

## Pricing

---

### ***Pricing Strategy***

We have set our product pricing based on a value-added premium to the commercial PHOTOPHONE product offered by Image Data Corporation, and our analysis of the competition in our market segment. Our goal is to achieve high product gross margins while offering our products at a substantial price advantage to present competition. Our ability to achieve these opposing goals of high margins and price leadership reflects our belief that we have developed and can defend a market niche that has very attractive potential profitability.

Our financial model assumes that our pricing declines by 10% in the second year after product introduction, and 5% per year thereafter, to account for the effects of emerging competition and continued price reductions in the commercial market. We believe that our gross margins will not be eroded by this price reduction due to manufacturing cost efficiencies as our shipment volumes increase.

### ***Commercial Product***

Our Fast-RIT product is priced competitively with the PHOTOPHONE at \$10,000, including high-resolution solid state camera and shipping case.

### ***Secure Desktop Products***

Our Sec-RIT product is priced at \$18,500. We do not offer the secure interface as an optional upgrade to the Fast-RIT since the price premium is greater than the market would bear for an encryption interface alone. We estimate that the TEMPEST Sec-RIT, when introduced in 1988, will have a list price of \$28,000, reflecting the substantial premium that TEMPEST products command in the marketplace.

### ***Mobile Products***

The ATR Sec-RIT carries a list price of \$24,480. Although a high margin product, this price is much lower than anything presently offered in today's market.

### ***Briefcase Products***

We estimate that the Field Sec-RIT, when introduced in 1988, will have a list price of \$18,500, slightly higher than the 1988 price for the Sec-RIT of \$16,650. We believe that offering this product at only a slight price premium to our desktop product, while providing substantial additional functionality, will serve to stimulate this new segment

---

# MARKETING

---

## Pricing

---

of our market. This product will be introduced in a TEMPEST version in 1989 for \$28,000.

### *Options and Spare Parts*

Each of our products are offered with optional features such as encryption interface cables and video printers. Many of our customers also require on-site quantities of spare parts. While these contribute to our revenues and profitability, our financial model does not include them.

### *Discounting*

Our published pricing does not include discounts for volume purchases. We anticipate that all volume purchases of our units will be by contract, and prefer to negotiate these on a case-by-case basis. We believe we can minimize volume discounting in the initial years due to the lack of substantial direct competition and the relatively small size of anticipated purchase contracts during the Test and Evaluation and Test Bed phases of our market development.

### *Price and Gross Margin Summary*

| Product                      | List Price      | Gross Margin % |
|------------------------------|-----------------|----------------|
| <i>Fast-RIT</i>              | \$10,000        | 41             |
| <i>Sec-RIT</i>               | \$18,500        | 67             |
| <i>ATR Sec-RIT</i>           | \$24,480        | 81             |
| <i>Field Sec-RIT</i>         | \$18,500 (est.) | 75             |
| <i>TEMPEST Sec-RIT</i>       | \$28,000 (est.) | 70             |
| <i>TEMPEST Field Sec-RIT</i> | \$28,000 (est.) | 70             |

---

# MARKETING

---

## Sales Status

---

### ***Background***

During our test marketing project we demonstrated our products to a number of user groups, some of whom became customers or placed orders in 1986. We started 1987 with a sales backlog and a growing list of groups who are interested in purchasing our products now that they have reached production status. We also have a list of groups who are interested in our products and are waiting for a product demonstration. Additional prospects have been identified who have received our literature, read a press release, or seen us at a conference. We are well positioned as our marketing activities expand in 1987 with an existing customer base and a database of qualified prospects to address.

This is our sales status as of the end of March, 1987:

### ***Current Customers***

We have three customer accounts presently in our target markets.

### ***Groups with Orders Pending***

A total of five customers have orders presently in progress, one of which is presently booked.

### ***Qualified Prospects***

We have demonstrated our products to 42 user groups who have applications for and interest in our products.

### ***Target Organizations***

Our database contains over 70 organizations in our target market known to have applications for imaging products. We believe that many of these organizations will yield multiple interested user groups as we address them.

### ***Press Release Responses***

We presently have 67 responses from our **Sec-RIT** press release to pursue.

---

# MARKETING

---

## Forecasts

---

### ***Introduction***

In this section we will discuss our model of the sales cycle for our products, how we develop our forecasts from this model, the prospect list we are targeting, and our detailed forecasts. We will present our a monthly forecast by product for 1987 and yearly for 1988-1991.

### ***Sales Cycle Model***

Purchasing practices in the Federal Government market differ substantially from the commercial market. We have already described the sales process in a previous section. The sales cycle model takes each step of this process and maps it against an approximate timeframe to complete each step. This model has been tested against our experience over the last year and by consultation with individuals who are experienced with government procurement, both on the user and vendor sides:

### ***Prospect Identification***

We have at present over 70 groups identified in the Department of Defense, Executive Office of the President, Department of Energy, Department of Justice, Department of the Treasury, and NASA.

### ***Step 1: Prospect Qualification***

We qualify the prospect through an initial telephone call before and after sending our product literature. *Elapsed time: one to two weeks.*

### ***Step 2: Demonstration Briefing***

Setting up and conducting the demonstration for the key decision makers and their staffs. *Elapsed time: two to four weeks.*

*Note: In many cases the first two steps may occur without our direct involvement, as present customers interest related user groups in our products.*

### ***Step 3: Test and Evaluation Units***

We close an order for two test and evaluation units and ship to the customer. *Elapsed time: three months.*

### ***Step 4: Contract for Test Bed***

Once the test and evaluation units are in place, we work with the user group to define their requirements, begin a dialog with the acquisition group who issues the contract, and then go through the contract submission and evaluation process. During this step

---

# MARKETING

---

## Forecasts

---

we strive to influence the requirements and work toward a streamlined method of contracting (sole source or limited competition). *Elapsed time: five months.*

### **Step 5: Delivering Test Bed Units**

This step involves our lead times and the delivery schedule specified on the contract. *Elapsed time: three months.*

### **Step 6: Volume Contract**

A large contract, or Basic Ordering Agreement, is a lengthy process that results in a competitive contract. This type of contract may involve volumes in the hundreds of units. *Elapsed time: one year.*

In summary, we plan on a four month process with a new account to close and ship our first order for two units, and an additional five months to turn on a contract for ten additional units. A year later we have the opportunity to win a large contract for volumes in the hundreds of units.

### **Forecast Development Assumptions**

We have made the following assumptions in the development of our forecasts:

- We have developed our forecasts by mapping the sales cycle model defined above against our prospect list.
- We expect that approximately forty percent of our revenues for 1987 will come from "test bed" contracts from a few key customers who presently have test and evaluation units in place. We expect that the other sixty percent will come from initial shipments of test and evaluation units to new customers.
- During 1988 we expect the initial seed units to develop into test beds, and additional test and evaluation units for new accounts.
- We have not forecasted large contract volumes until 1989.
- Our forecasts assume that our first year revenues are entirely generated through direct sales.
- During 1987 we will develop indirect channels of distribution which we expect to contribute to our revenues in 1988-1991.



---

# MARKETING

---

## Forecasts

---

- Our forecasts are for our primary encryption-compatible image transceivers for the government market. Sale of networking products, or sale of non-secure versions of our products into the commercial market, are not included. Spare parts and options, such as cables or video printers, are also not included. Therefore we believe that there is upside potential in our forecasts.

### ***Prospect List***

Although we have a large prospect list already generated, we expect from past history that we will add many new prospects through customer referrals, trade shows, advertising, and future marketing partnerships with companies who will represent or resell our products. During our test marketing, we developed a list of over thirty qualified prospects for our products, by agency, department, and contact point. This list is highly proprietary and is therefore not presented here.

The following organizations within the Federal Government represent the market from which our present and future prospects are taken:

- **Department of Defense**
  - Joint Chiefs of Staff
  - National Military Command System
  - Joint Special Operations Agency
  - Joint Special Operations Command
  - Joint Tactical Command, Control, & Communications Agency
  - Unified and Specified Commands (Commanders in Chief)
    - CINCLANT
    - CINCPAC
    - CINCEUR
    - US SOUTHCOM
    - NORAD
    - Space Command
    - Strategic Air Command
    - Tactical Air Command
    - Military Airlift Command
  - National Security Agency
  - Defense Intelligence Agency
  - Defense Communications Agency
  - **Department of the Army**
    - Army Intelligence
    - Army Special Operations
    - Information Systems Command
    - Training & Doctrine Command
    - CECOM

---

# MARKETING

---

## Forecasts

---

- **Department of the Navy**
  - Navy Intelligence
  - Information Systems Command
  - SEALS
  
- **Department of the Air Force**
  - Information Systems Command
  - Command, Communications, Control and Computers
  - Air Force Intelligence
  - Air Force Special Operations
  
- **Department of the Marine Corps**
  - Marine Intelligence
  
- **Executive Office of the President**
  - White House Communications Agency
  - Central Intelligence Agency
  
- **Department of Energy**
  - Los Alamos Labs
  - Sandea Labs
  
- **Department of Justice**
  - Federal Bureau of Investigation
  - Drug Enforcement Administration
  
- **Department of the Treasury**
  - Secret Service
  
- **N A S A**
  - N A S A Headquarters
  - Johnson Space Center
  - Goddard Space Flight Center
  - Jet Propulsion Laboratories
  - Kennedy Space Center
  - Vandenberg AF
  - White Sands Test Facility
  - Ames Research Center
  - International Tracking Stations
    - Goldstone Tracking Station
    - Madrid Tracking Station
    - Australia Tracking Station

# MARKETING

---

## Forecasts

---

### ***Shipment Forecast - 1987***

The accompanying chart presents our forecast for 1987. We have made additional assumptions in developing this forecast:

- Shipments for January-May reflect units to present customers and prospects who have been waiting for test and evaluation units. No active marketing occurs during this interval, pending availability of funding to expand marketing activities.
- Shipments of 10 units per month for June-August assume that we are awarded a contract for a "test bed" for our **ATR-RIT**.
- Shipments of 8 units per month for August-November are test and evaluation units placed in 20 user groups that are presently identified. It is assumed that active marketing to these groups begins in May, 1987 after the corporation is funded to expand marketing activities.
- Shipment volumes are forecasted for two products only: the **Sec-RIT** and the **ATR-RIT**.

---

# MARKETING

---

## Forecasts

---

---

### PHOTOTELEESIS 1987 SHIPMENT FORECAST

| Prod.      | Jan | Feb | Mar | Apr | May | Jun | Jul | Aug | Sep | Oct | Nov | Dec | Total |
|------------|-----|-----|-----|-----|-----|-----|-----|-----|-----|-----|-----|-----|-------|
| Sec<br>RIT | 0   | 1   | 2   | 2   | 1   | 3   | 3   | 7   | 8   | 8   | 18  | 0   | 53    |
| ATR<br>RIT | 0   | 1   | 0   | 1   | 0   | 7   | 7   | 11  | 0   | 0   | 0   | 0   | 27    |
| Total      | 0   | 2   | 2   | 3   | 1   | 10  | 10  | 18  | 8   | 8   | 18  | 0   | 80    |
| Cum.       | 0   | 2   | 4   | 7   | 8   | 18  | 28  | 46  | 54  | 62  | 80  | 80  | 80    |

---

# MARKETING

---

## Forecasts

---

### *Shipment Forecast for 1987-1991*

Our five-year shipment forecast is presented in the accompanying chart, including the summary from the 1987 results. Assumptions specific to this forecast are as follows:

- In 1988 we assume that the test and evaluation units placed in 1987 grow into test bed units, yielding approximately 200 units from the initial 20 customers. In addition, we develop 20 new customers who order initial test and evaluation units.
- No major contract volumes are forecasted for 1988, but it is assumed that contracts are bid starting in 1988 which will account for significant growth in volumes from 1989 through 1991.
- We begin shipments of our **Field Sec-RIT**, or military briefcase product, the first quarter of 1988.
- Our TEMPEST desktop units begin shipments mid-year in 1988. This is followed by our briefcase TEMPEST unit in the first quarter of 1989. Shipments of our non-TEMPEST **Sec-RIT** declines as the TEMPEST units become dominant.
- Shipments of the **Fast-RIT** product are flat over the forecast period, reflecting a modest level of non-secure product demand, predominately through listing on the Government Services Administration price lists.

---

# MARKETING

---

## Forecasts

---

---

### PRODUCT SHIPMENTS 1987-1991

| Product/Year         | 87 | 88  | 89  | 90   | 91   | Total |
|----------------------|----|-----|-----|------|------|-------|
| Fast-RIT             | 0  | 50  | 50  | 50   | 50   | 200   |
| Sec-RIT              | 53 | 150 | 100 | 50   | 0    | 353   |
| ATR Sec-RIT          | 27 | 100 | 250 | 500  | 700  | 1577  |
| Field Sec-RIT        | -  | 70  | 150 | 300  | 500  | 1020  |
| TEMPEST<br>Sec-RIT   | -  | 30  | 150 | 500  | 1000 | 1680  |
| TEMPEST<br>Field-RIT | -  | -   | 100 | 200  | 300  | 600   |
| Total Shipments      | 80 | 400 | 800 | 1600 | 2550 | 5783  |

---

# MARKETING

---

## Distribution

---

### ***Distribution Strategy***

Our distribution strategy combines direct sales methods using our own personnel and indirect methods using resellers.

### ***Direct Sales***

PHOTOTELESIS personnel are responsible for direct sales. We intend for direct sales to provide the bulk of our business in 1987 because

- our technology is new and complex
- we can provide closer customer contact and better support
- we realize greater profits

### ***Indirect Sales***

We will use indirect sales channels to increase our market penetration without a large increase in marketing and sales overhead. We will select resellers who are well known in our markets, can support our volume requirements, and are willing to provide the level of support and service our customers demand. These indirect channels include

- Manufacturers Representatives
- Value-Added Resellers
- Prime Contractors

---

# MARKETING

---

## Distribution

---

This diagram illustrates our distribution strategy:

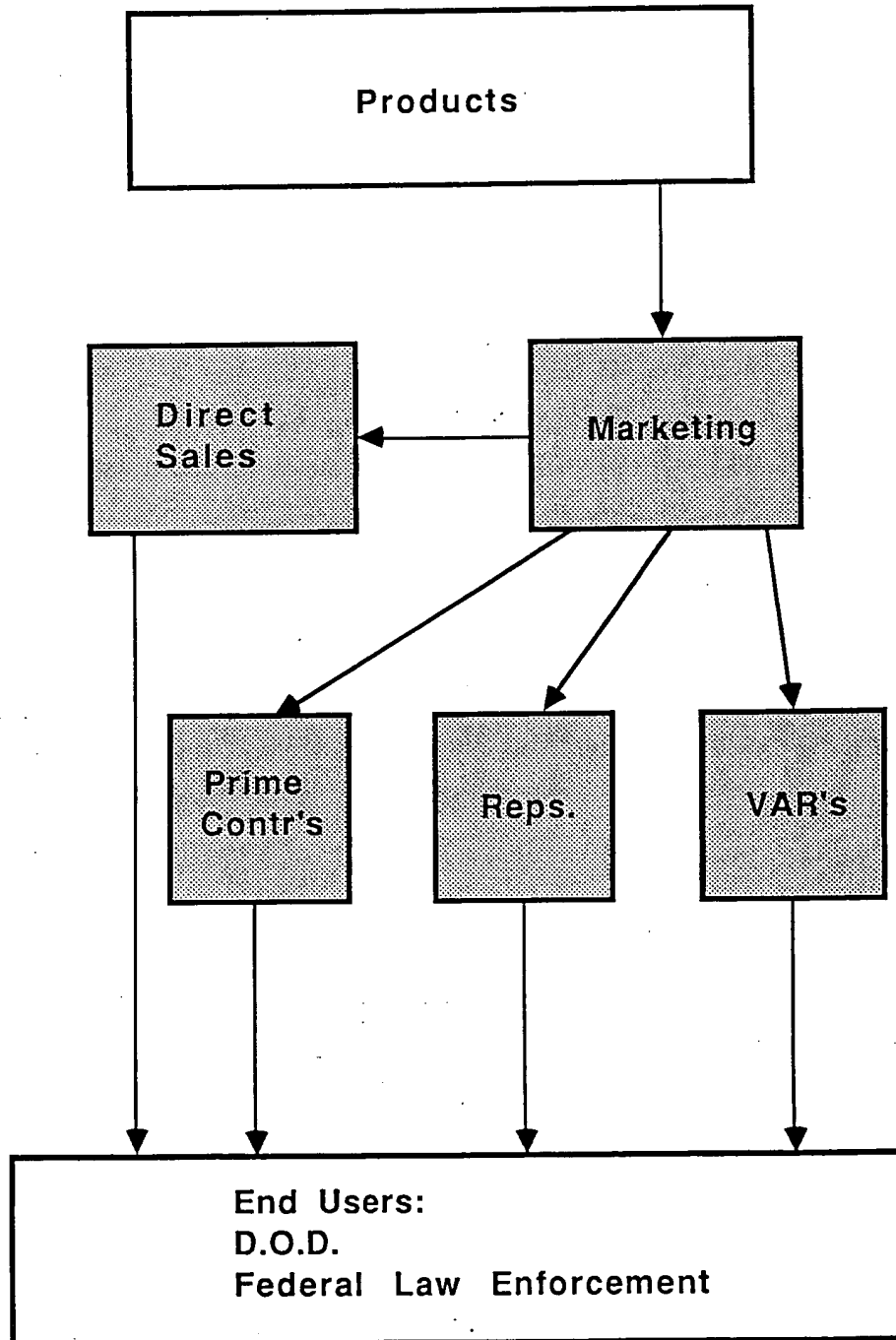



---

# MARKETING

---

## Government Contracts

---

### ***Small Department of Defense Contracts***

Department of Defense purchases for \$25,000 or less are handled through oral or brief written requests, known as Request for Quotations (RFQ's). The successful quoter is issued a purchase order, and compliance with the order constitutes contract acceptance and fulfillment. The contracting officer has the discretion to choose how widely the RFQ is solicited.

This procedure can be used by our prospects and customers on a limited basis when purchasing test and evaluation units, although two of our encrypted Sec-RIT or ATR-RIT products exceed the \$25,000 order maximum.

### ***Bids and Proposals***

However, although these purchase orders represent nearly 98 percent of DOD's contract actions, they are only 20 percent of the procurement dollars spent. The other 80 percent involve formal solicitation procedures that require written offers called sealed bids or competitive proposals. Sealed bids are sought by means of **Invitations for Bids (IFBs)**; competitive proposals are sought by **Requests for Proposals (RFPs)**.

Because major RFPs and IFBs are complex to administer, it may take up to a year for a large contract to be awarded. Shortcuts have been developed which permit the timeframe to be shortened for situations where there is only one source or a limited number of sources for the product or service.

***Competitive Unpublished Contracts:*** Some contracts which have a value under \$1 million can avoid publishing the proposed procurement in the government's Commerce Business Daily newspaper. This shortens the procurement cycle and also limits the number of possible responses.

***Sole Source Contracts:*** In very limited circumstances, where a contract requirement can only be filled by one vendor, the contracting office can greatly speed up the purchase by soliciting only one contractor. This method is usually restricted to contracts of \$125,000 or less.

We expect that most contracts for our products will be IFBs or RFPs; based on experience, we believe that our product uniqueness will allow many contracts for test and evaluation units or test beds to use a streamlined process.

---

# MARKETING

---

## Government Contracts

---

### ***Unsolicited Proposals***

Some contracts result from unsolicited proposals submitted by groups who feel they have an innovative and unique method or approach to accomplish a DOD mission. We have used this approach in one instance during our test marketing and plan to continue its use as our marketing activities expand.

### ***General Services Administration Contracts***

A special type of contract is administered through the General Services Administration (GSA), which provides catalog purchasing abilities on a pre-negotiated basis to government and government-related groups. Many groups who are interested in our products have expressed a desire to be able to purchase limited quantities through the GSA. Orders under GSA are typically limited to \$50,000, although this ceiling can be waived under selected circumstances. We plan to introduce our product on the GSA's New Products Listing this year and have applied for a new listing category for image transmission products for future use.

The following chart summarizes the types of contracts described above, the approximate contract lead time, and the typical per order dollar ceiling.

---

# MARKETING

---

## Government Contracts

---

This chart summarizes the types of contracts that the government will use to purchase our products.

| <b>Contract Type</b>                            | <b>Lead Time</b>        | <b>Per Order Limit</b> |
|---|-------------------------|------------------------|
| Purchase Order                                  | 2-3 months              | \$25,000               |
| Bid and Proposal<br>-SoleSource                 | 3-6 months              | \$125,000              |
| Bid and Proposal<br>-Competitive<br>Unpublished | 3-6 months              | \$1 million            |
| Bid and Proposal<br>- Competitive<br>Published  | up to<br>1 year         | no limit               |
| General Services<br>Administration              | none -<br>prenegotiated | \$50,000               |

---

# Notes

---

---

---

---

**PHOTOTELEESIS-CONFIDENTIAL**

# *Technology*

---

# TECHNOLOGY

---

## PHOTOTELESIS Proprietary

---

### ***Proprietary Technology***

We have developed proprietary technology which enables us to meet the needs of our customers for image communications products. Our investment in market research, and our products which reflect that research, represent our uniqueness in the market and the principal barrier to future competition.

### ***We presently own the following proprietary technology:***

- COMSEC (secure communications) interface designs which enable us to connect with government-supplied encryption devices
- RF-shielded packaging, which enables us to work in environments which process sensitive information
- Radio interface designs, which enable us to connect to non-secure radios and cellular telephones
- Low-power-consumption electronics designs, which enable us to work with DC and battery power
- ATR (Aircraft Transport Racking) packaging, which enables us to work in vehicular environments such as aircraft, ships, and land vehicles.

### ***We are presently developing technology for...***

- briefcase packaging
- image database systems
- TEMPEST qualification.

**PHOTOTELESIS-CONFIDENTIAL**

---

# TECHNOLOGY

---

## PHOTOTELESIS Proprietary

---

Our proprietary technology is contained in these subsystems and products:

### ***Communication Interface Subsystem***

Cellular  
Satellite  
Two-way Radio

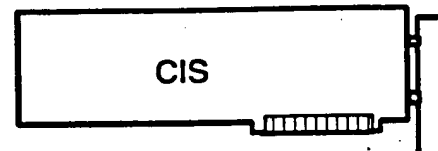

### ***Encryption Interface Subsystem***

Ground to Air  
Satellite  
Line of Sight

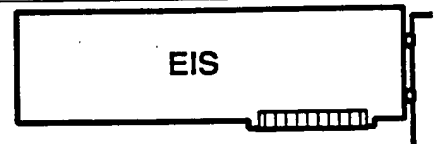

### ***Control Processor I***

Forward Error Correction  
Custom communications software  
Remote control capability

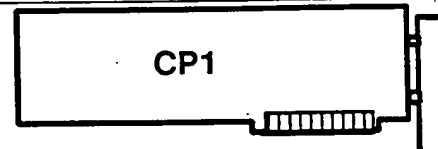

### ***ATR Package***

Aircraft Transport Racking spec.  
DC or battery power  
Ruggedized  
Cellular or  
Secure

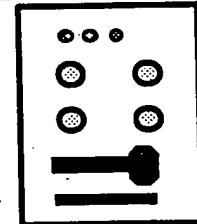

### ***Field Package***

Briefcase Portable  
Battery powered  
Cellular or  
Secure

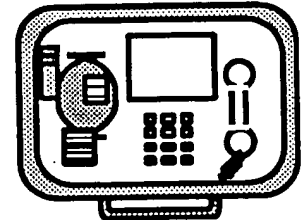

### ***Image Data Base***

Software Database  
Multi-user  
Telephone or Secure

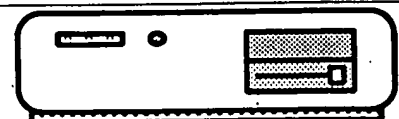

---

PHOTOTELESIS-CONFIDENTIAL

---

# TECHNOLOGY

---

## Licensed

---

We buy certain off-the-shelf equipment and license certain technology from Image Data Corporation.

Specific technology we presently license from Image Data includes:

- Processor design
- Video subsystem design
- Software design.

Our unique value added lies in:

- Communications subsystems
- Packaging
- Specialized software.

**PHOTOTELEESIS-CONFIDENTIAL**



---

# Notes

---

---

---

---

**PHOTOTELEESIS-CONFIDENTIAL**

# ***Products***

---

# PRODUCTS

---

## Introduction

---

In this section of the business plan we will introduce our products. We will provide a rationale as to how we arrived at our product mix. Then we will give you specific information about each of the products. Finally, we will provide a product availability schedule showing our product timetable.

Promotional literature containing further information about our products is included in this package for your information.

### ***About our products***

Basically, our products consist of a matrix of packaging and communications options. Not all combinations are offered because not all combinations make sense. Essentially, we provide configurations to suit the practical requirements of the government's various combinations of applications and communications requirements.

---

# PRODUCTS

---

## Strategy

---

### ***Our product strategy***

Our product strategy begins with commercially available products, to which we add significant proprietary value. These enhanced products become our product line.

### ***Core Technology***

We begin with standard, "off-the-shelf" technology from Image Data Corporation:

- PHOTOPHONE™
- PHOTOBRIDGE™
- PHOTOGATE™

### ***Added Technology***

Then, after acquiring off the shelf base units, we develop new designs based on technology licensed from Image Data, integrate off-the-shelf OEM components, and then add our proprietary technology.

### ***Result***

The resulting products and systems comprise the PHOTOTELESIS product family. This strategy is illustrated on the facing page.

---

# PRODUCTS

---

## Strategy Illustration

---

Here, in graphic form, is the product strategy discussed on the previous page.

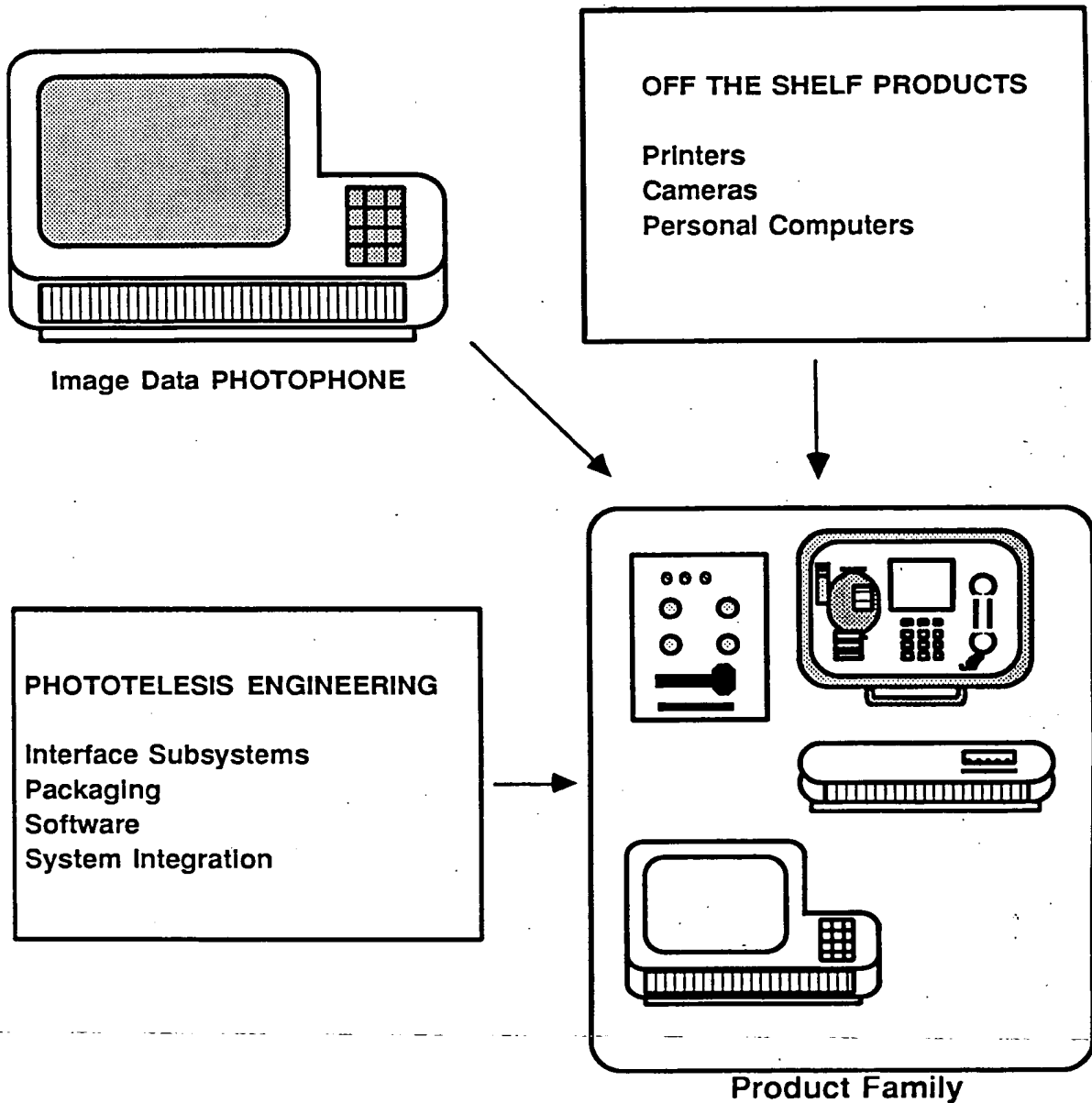

**PHOTOTELEESIS-CONFIDENTIAL**

---

# PRODUCTS

---

## Packaging Options

---

Different applications require different packages; our product line meets those requirements.

### *Desktop Products:*

---

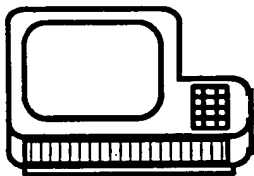

Our desktop family allows image communications in the office, acting as a "base station" for remote units located in the field.

### *ATR Products*

---

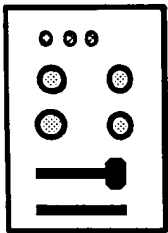

Our ATR family puts image communications to work in the field, where it may be mounted on:

- aircraft,
- shipboard, or
- in a vehicle.

We offer both secure and non-secure versions for many types of existing communications systems.

### *Briefcase Products*

---

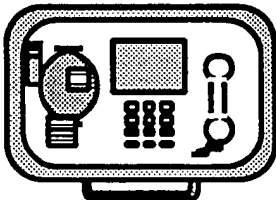

Our briefcase family is the ultimate in portable image communications, with battery operation and a full range of secure and non-secure communications options.

### *Network Products*

---



We meet needs for networking images with:

- ImageBridge, for image conferencing, and
- ImageBase, for remote image storage and retrieval.



---

**PHOTOTELEESIS—CONFIDENTIAL**

# MicroRIT™ Proposal

---

## *Table of Contents*

---

### Section 1 - Executive Summary

- 1.0 PhotoTelesis Background
- 1.1 Texas Instruments Background
- 1.2 The Combined Team
- 1.3 Program Background

### Section 2 - Technical Approach

- 2.0 Capturing Video
- 2.1 Video Demodulation
- 2.2 Image Compression
- 2.3 Image Storage
- 2.4 Communications
- 2.5 User Interface
- 2.6 Hardware
  - 2.6.1 Packaging
  - 2.6.2 Hardware Implementation
  - 2.6.3 Memory
  - 2.6.4 I/O Ports
  - 2.6.5 Power Sources

### Section 3 - Cost

- 3.0 Schedule
- 3.1 GFE
- 3.2 Personnel
- 3.3 Attachments

### Section 4 - Product Specifications

### Section 5 - Drawing and Block Diagram

### Section 6 - Schedule

### Section 7 - Cost Detail

### Section 8 - Personnel Resumes

# SECTION 1

## EXECUTIVE SUMMARY



# MicroRIT™ Proposal

2 November 1995

## EXECUTIVE SUMMARY

This unsolicited proposal describes a state-of-the-art image transmitter that is specifically designed for field agent applications with handheld and vehicle mounted digital/secure radios. The MicroRIT image transmitter will capture and transmit high quality monochrome or color images over typical radio circuits, such as the Government Saber Secure Radio on the B-Radio net or commercial cellular phone circuits. The MicroRIT is unique because it can transmit a high quality image in ten to twenty seconds from a unit that is small, low power, and *low cost*. This unique capability is currently unavailable and is crucial for field law enforcement applications.

This MicroRIT miniaturized image transmitter proposal is submitted by PhotoTelesis, a Business of Texas Instruments Incorporated. The PhotoTelesis group is a world leader in Tactical Image Transmission technology, and Texas Instruments (TI) is a world leader in Digital Signal Processing technology and Micro Electronics technology. The proven track records and technology bases of the PhotoTelesis/TI combined team places this technically challenging program well within reach.

### 1.0 The PhotoTelesis Organization Background:

PhotoTelesis has a 10 year history of specialization in Government tactical image transmission. PhotoTelesis is the leader in tactical transmission of monochrome or color imagery, captured from either television or digital cameras over Government secure radios, Government satellite circuits, and commercial cellular and satellite radios.

The company has installed more than 1000 systems within the Army, Navy, Air Force, Special Operations, Federal Law Enforcement, and Intelligence groups. These systems have been used in classified and unclassified operations. The PhotoTelesis name has become well known as the leader in the tactical image transmission field.

The PhotoTelesis comprehensive product line provides users with a full complement of hardware and software, to support operation from various platforms, including:

- ⇒ Man Portable Applications
- ⇒ Covert Operations
- ⇒ Aircraft Platforms
- ⇒ Ground Vehicle Platforms
- ⇒ Portable Base Stations
- ⇒ Fixed Base Stations

The tactical communications functions of the PhotoTelesis products include:

- ⇒ Distribution of images, text and data over all government secure voice bandwidth circuits.
- ⇒ Database Archiving of stored images and text data.
- ⇒ Traditional Data Processing activities in MS-DOS and Windows
- ⇒ Interoperability with Government NITFS 2.0 "National Imagery Transmission Systems"

### *Distinctive Competence*

A unique blend of Independent Research and Development, combined with commercial off-the-shelf technology, has allowed PhotoTelesis to offer products with innovative designs and superior performance at competitive prices. The modular construction of products allows easy technology insertion of hardware and software enhancements lowering life cycle costs.

The success of PhotoTelesis can be attributed to a commitment to service and providing solutions to our customer problems. Our reputation has been earned by focusing our expertise in the following key areas:

- **Reliable/Dependable Transmission of Data.** Imagery and Data can be sent from a harsh tactical environment where air time for transmissions is limited. Users depend upon their equipment to transmit images and data reliably over wideband SATCOM or narrowband communication channels. To compensate for natural and man-made noise, PhotoTelesis' proprietary protocols incorporate error correction techniques and compression algorithms that provide both efficient and reliable transmissions. These message and image transmission protocols are specifically designed for noisy narrow-band radio communications, and are currently heavily used in operations involving Command, Control, Communications, and Intelligence (C4I) applications.
- **Ease of Operation for the User.** The operational simplicity and versatility of both hardware and software design allow non-technical user compatibility with a wide range of cryptologic devices, secure telephones, and radios. The systems are designed to be automatically configured by cable connections reducing hardware damage by operator error. The equipment is built with user friendly interfaces (GUI) or a menu driven screen.
- **Products for Various Platforms.** The company has focused on customer requirements to develop, with IR&D funds, products used on various platforms, i.e., vehicle, aircraft, and man-portable units. This has resulted in building a repertoire of off-the-shelf products for Aircraft, Special Operations, and Law Enforcement.
- **Rapid Product Development.** PhotoTelesis has reduced the time and cost of product development, from product definition through design, development, and pilot production. This is accomplished by significant technology re-use, in conjunction with strong specialized skill sets of the engineering team. The majority of the PhotoTelesis products have been sold as Non-

Developed-Items on Indefinite Delivery Order or Fixed Priced Contracts, thus reducing customer financial and technical risks.

### **1.1 Texas Instruments (TI) Incorporated Background:**

Texas Instruments has diverse capability in micro-electronics, Government, commercial, and consumer products. TI is a high technology company with sales or manufacturing operations in more than 30 countries; a major supplier of integrated high performance EO based fire control systems, high performance processors, thermal sensors, missile systems, and radar components to the U.S. Department of Defense (DoD). The MicroRIT program will utilize several key TI capabilities:

TI is a world leader in Digital Signal Processing (DSP) technology. The DSP is key to the MicroRIT's small size, low power, and low cost. Commercial technology and the capability for high volume production also provide opportunity for significant unit cost reductions, allowing for *extensive* deployment of the technology at a *very affordable* cost.

### **1.2 The Combined PhotoTelesis/Texas Instruments Team:**

On August 18, 1995, PhotoTelesis Corporation was acquired by Texas Instruments Incorporated. PhotoTelesis' expertise with tactical image transmission combined with the financial strength of Texas Instruments offer our customers innovative and cost effective tactical imaging product solutions.

PhotoTelesis and Texas Instruments have a two year continuing history of cooperation and teaming on other Government imagery programs, including the US Army Hunter Sensor Suite program and the Lightweight Video Reconnaissance System (LVRS) program.

PhotoTelesis/Texas Instruments is excited about the opportunity to provide new state-of-the-art capability through more closely integrated efforts on the part of all team members.

### **1.3 The Program Background:**

Tactical Imagery has proven to be the most efficient and quickest means to distribute critical information to the decision maker. Imagery in the field can provide agents with near-real time secure surveillance that improves their situational awareness, suspect identification capability, and thus, reduces allocation of limited personnel resources. Unfortunately, both military and commercial products used for transmission of Tactical Imagery are currently unsuitable for law enforcement because the military products are too large and too expensive, and the commercial products are too large and are not capable of operation over Government tactical radio circuits.

~~Current generation Remote Image Transceivers (RIT's) manufactured by PhotoTelesis are in operation over the Motorola digital radio systems owned by the Government for the purpose of transmitting secure (encrypted) imagery from mobile platforms to fixed sites.~~

Still Imagery is being transmitted using the SABER II, with the Secure INDICTOR option, at 12Kbps. A primary requirement of maintaining minimum data transmission times and a quick restoration of the radio-to-voice communications have been met in product demonstrations of this capability. At a recent test, using the PhotoTelesis man-pack TAC-RIT, monochrome images at a resolution 592 by 440, 8-bit pixels were transmitted in 8 seconds using Wavelet compression, and 21 seconds using industry standard JPEG compression.

This proposal describes an engineering program that miniaturizes the PhotoTelesis current capability into a very small, covert, low power Remote Image Transmitter (MicroRIT) *specifically* designed for agent use. The primary goals for field agent use are:

- ⇒ Very Small Size (Cellular phone size)
- ⇒ Low Power (2-4 watts)
- ⇒ Simple User Interface
- ⇒ Fast Transmission Time
- ⇒ Monochrome or Color Use

# **SECTION 2**

## **TECHNICAL APPROACH**

## TECHNICAL APPROACH

Until the advent of small, low power digital signal processor (DSP) semiconductors, the MicroRIT was unfeasible. Now, however, such DSP's allow the design of very small, but highly sophisticated data acquisition and processing devices. In fact, the DSP component is the heart of the MicroRIT, controlling all aspects of its operation from video acquisition, to image compression, to tactical communications protocol, to user interface.

A digital signal processor, or DSP, is a special type of microprocessor that has been highly optimized for numerical computations (namely digital signal processing) which involve long sequences of multiplication and addition operations. Digital filters, spectrum analyzers, and data compression algorithms fall squarely in this category. While the DSP is not often used as a generalized host processor (such as an 80486, Pentium, or 68000), it can certainly be used as a host CPU. Because of the particular hardware optimizations that were implemented for digital signal processing, a DSP tends to have smaller address spaces (under 1 megabyte) and less support for string-oriented operations (for handling character strings). However, several DSP variants can quite easily be used as an embedded controller and signal processor - obviating the need for two separate processors. This often simplifies the hardware design and interprocessor communications mechanisms.

The MicroRIT was conceptualized specifically with a DSP as the system controller in mind to reduce the size and power requirements of the unit. In addition, to controlling the overall system function, the DSP is responsible for controlling the digitization of video, the compression of this captured video, and the communications protocol and link-layer interface. These functions would occur serially. That is, it would not be possible to be capturing video while sending a compressed image at the same time. This one-at-a-time restriction is due to two problems. The first is the limited amount of multi-tasking support in the DSP architecture. Few DSP operating systems are available that support preemptive multi-tasking. The second is the limited address space of the DSP. Many DSP's have a fairly limited address space - often under 64K words! This will require that both the codespace and the dataspace be page-swapped. Page-swapping essentially means that only one software function can be active at a time - which implies the serial nature of the major functions.

### 2.0 Capturing Video

A conventional frame grabber contains a great deal of circuitry necessary for demodulating the video signal, identifying and triggering off the vertical sync signal, stripping the sync signals from the image data, digitizing the demodulated data, and storing it in a dual-ported RAM. This is required because the host processor has neither access to the raw video signal, nor the processing power to execute these functions in a real-time fashion. The DSP used in the MicroRIT approach, will however, be controlling the video digitization while itself does the vertical sync identification. External analog-to-digital converters (ADC) will still be used to digitize the video signal, rather than using any onboard ADC capabilities of the DSP chip, because most DSP ADC's are not fast enough to digitize at video rates (at least those DSP's that can meet our low-power requirements). Another subtle point about this approach is that video need only be digitized on user demand. This implies that the video ADC circuitry only has to be energized for 1-2 frame times to acquire the image. Video ADC's can consume several watts if left free running. The non-requirement for video output allows this digitization-on-demand

approach that should significantly help reduce size, weight, and heat dissipation, as well as extend battery life.

## 2.1 Video Demodulation

A color video signal, in particular a composite color video signal, carries the luminance and color (chrominance) information in different frequency bands. Usually, an analog filter is used to separate these signals into two analog channels that can then be digitized separately. In order to save power and space in the MicroRIT, we will perform this demodulation in software running on the DSP after a frame's worth of video data has been captured. Even an S-Video signal carries two color channels on the chrominance signal (which is physically separated from the luminance channel). The same type of *software* demodulation will be done on the S-Video chrominance channel for S-Video. The video demodulation is performed after a frame acquisition, not during. This is significant because it restricts the MicroRIT to performing system functions in a serial fashion. That is, one high level function after another is performed by the central processor (the DSP). There is no multitasking of system functionality in the MicroRIT. This is due in part to the lack of multitasking DSP operating systems as well as the somewhat limited addressing capability of today's DSP's (under 1 megabyte of codespace). Thus, after the user specifies that an image is to be acquired, the video digitization circuitry powers up, acquires a frame of video data, and passes control to the video demodulation software which then separates luminance from the color signal by a digital filter.

## 2.2 Image Compression

After the image has been digitized, separated, and demodulated by the system DSP, it will be compressed with either the JPEG or PhotoTelesis wavelet image compressor. This choice is user selectable (via the set of buttons and alphanumeric display). The wavelet compressor is well suited to the S-Video type of input since it was designed to work on L/Cr/Cb video data. Like all other PhotoTelesis implementations of the wavelet codec, the user will be able to select several choice of compression ratio and/or "quality". PhotoTelesis is constantly improving its image compression technology. These improvements affect compression/decompression time and image quality. They also affect compression features such as, quality specification (Q-Factor), multiresolution compression, and industry standardization. The contractor will strive to incorporate image compression improvements into the MicroRIT product, subject to the program schedule.

## 2.3 Image Storage

There will be enough battery-backed SRAM within the MicroRIT to hold 40 wavelet compressed color images. These can be held on-board until downloaded to a host computer via an RS-232 port. Originally, it was conceived to use a PCMCIA SRAM card for this image storage. However, the physical size of the mechanical PCMCIA slot and the extra interface circuitry was not justified. If the images are stored within the MicroRIT, the user will have to bring back something, be it the MicroRIT or a PCMCIA card, in order to offload the images to some sort of Base-Station unit. Thus, the SRAM memory was chosen over PCMCIA.

## 2.4 Communications

The MicroRIT will be able to connect to all standard COMSEC equipment including STU-III's, SINCGAR's, SABER and RACAL (MHSR) radios, KY-57, KY-58, and Sunburst. The DSP processor will run the PTAC and PTAC-2 (required for file pull capability) protocols in order to

be backward compatible with existing PhotoTelesis equipment. The DSP will also directly control all COMSEC control lines (PTT, BDMC, etc.) as well. The DSP and some glue logic will essentially replace the original EIS card of the PhotoTelesis ACT product line.

Note that this version of the MicroRIT will not include the NITFS TACO-2 protocol. There is an assumption that the MicroRIT will be communicating with other PhotoTelesis equipment (i.e., Base Stations) which do have the TACO-2 capability.

Note that the automatic voice/data cutover modes for the KY-57 and KY-58 will not be implemented. Manual data switching will be used.

## 2.5 User Interface

The user will be able to interface to the MicroRIT two ways: 1) the set of onboard pushbuttons, 2) an RS-232 cable linking the MicroRIT to a host computer. There will be five (5) buttons on the MicroRIT to control normal operation of the system. There will also be an alphanumeric display for status and menu information. The functions on the MicroRIT will include power (on/off), capture, send, and menu. The menu will allow the specification of compression type, compression ratio, protocol, call sign information, send/hold modes, etc.

The RS-232 interface to the MicroRIT will be used for 3 functions: 1) Update system software (stored in FlashRAM on the MicroRIT), 2) download configuration information to the MicroRIT (call sign lists, compression defaults, etc.), and 3) download compressed/stored images from the MicroRIT to a workstation (such as an MIT-301). This will be a very simple RS-232 interface with a subminiature connector on the MicroRIT to the standard 9-pin COM connector on a PC.

## 2.6 Hardware

**2.6.1 Packaging.** The MicroRIT is designed to utilize standard snap on cellular telephone batteries. Several battery sizes and capacities are available from telephone retail outlets. The MicroRIT's overall size approximates that of a hand-held cellular flip-phone. High capacity battery life is estimated at 1 hour of full operation, with standby time approaching 30 hours.

The initial design and packaging will be implemented with an aluminum machined case. The finish will be black anodized for cosmetic finish. High volume applications could be done with a plastic injected molded case, but these costs are not included in the funding proposals submitted. A conceptual drawing is shown in Figure 1. The display and interface panel will allow system status and operational menus to be displayed to the operator. There is a recessed subminiature-D connector on the bottom edge of the unit that provides all input/output connections. If this unit is used in embedded system applications, external power can also be provided through this same connector. The connector is recessed to prevent damage to the connector by accidental dropping or striking other objects. The connector is installed on the bottom edge to provide best comfort to the operator when the cable is installed.

This MicroRIT package design will also include the ability to embed this device in higher capability equipment. Examples include radios, portable video equipment, or other equipment including cameras and radio transmission capabilities. This concept is similar to equipment with font cartridges, game cartridges, etc. The operator interface and display panel will not be included on these embedded applications. Power will be supplied through the external I/O connector.



**2.6.2 Hardware Implementation.** The MicroRIT architecture is based on the Texas Instruments TMS320 series of Digital Signal Processors. This DSP is the core of the design, with additional components providing the input/output interfaces to the operator, external power source, radios/Cryptos, and external computer links. There is one D-subminiature connector that provides these I/O functions. There are 5 control buttons, along with an alpha-numeric LED display for operator control and feedback status. The Overall block diagram is shown in Figure 2.

**2.6.3 Memory.** The memory implemented in the MicroRIT consists of low-power Static Rams (S-Rams). These memories are page partitioned to provide both program storage, raw video data workspace, as well as compressed video image storage. The design goal is to provide the capability to store a minimum of 40 images of 32K each in compressed image size. The architecture provides one memory page per image when storing compressed images.

**2.6.4 I/O Ports.** There are 2 input/output Serial ports incorporated into the design. One is designated for communication over radios, Crypto's, and STU type telephone devices. The other is intended for interfacing to other standard RS-232 computer devices such as Global Positioning Systems, some camera devices, and personal computer links for downloading image data or downloading operating program software. If the system needs to be reprogrammed for different mission requirements, the planned mechanism is to download from any serial computer device, the operating parameters and program software. If the user elects to save images, rather than send them immediately, these saved images could also be downloaded from the internal S-RAM memory via this serial port.

**2.6.5 Power Sources.** The MicroRIT is powered from either an attached cellular phone compatible battery, or via external power input through the I/O connector. For extended operating times, the external power mode is used. The input DC voltage range is 5.5-8.0 volt.

# SECTION 3

**COST**

## COST

The project represents a significant development effort with a medium level of risk. The contractor is keenly aware of the budget constraints and has taken steps to reduce the government's cost. The proposed cost has been reduced by the contractor's program investment of \$576K and utilization of the contractor's Image Compression and Communication Software, which was previously developed with IR&D funds.

The development effort is allocated into hardware engineering and software engineering as follows:

|                               |                       |
|-------------------------------|-----------------------|
| Hardware                      | \$661,093.80          |
| Software                      | <u>\$984,492.21</u>   |
| Total Development Effort      | \$1,645,586.01        |
| Less: Contractor's Investment | <u>(\$645,586.01)</u> |
| Cost to government            | \$1,000,000.00        |

Upon completion of the project the government will receive 2 prototypes. The production cost per unit is targeted to be \$3,000.00-\$4,000.00 in lot sizes of 100. Cost reductions are possible by tooling the cage for plastic injection molding based upon higher volumes.

### 3.0 Schedule

The contractor anticipates the project will require 12 months from inception to prototype delivery. After prototype delivery, unit production could begin immediately. Attached are program schedules for Hardware and Software.

### 3.1 GFE

The contractor will require two SABRE II radios for testing during the program.

### 3.2 Personnel

The contractor will assign two Engineering managers and one program manager to this project. Their resumes are attached:

#### SOFTWARE

Dr. Bruce Mather.....Manager of Software Engineering

#### ELECTRONICS HARDWARE

Roger Vest.....Manager of Hardware Engineering

#### PROGRAM MANAGEMENT

Bill Kidd.....Program Manager

### 3.3 Attachments:

1. Micro-RIT Technical Specifications
2. Block Diagram
3. Drawing
4. Program Schedule
5. Detail Costs

# SECTION 4

## PRODUCT SPECIFICATIONS

## MicoRIT Functional & Physical Specifications

|  |  |
|--|--|
| Video Input:   | Color/Monochrome<br>Composite/S-Video<br>640 x 480 x 16-bit color (8-bit grayscale)<br>768 x 512                                     |
| Image Storage:   | Onboard flash (or battery-backed SRAM) for 40 + compressed color images (@32K)   |
| Video Output:  | None   |
| Audio:   | Digitized voice annotation will be provided  |
| Comms:   | PTAC (KY-57, Sunburst/STU-III, Sincgars, Saber)  |
| RS-232 Interface:  | External GPS receiver, S/W update, offload images, system configuration (call sign download, etc.)                                   |
| User Controls:   | Five (5) buttons - (1) On/Off and (4) controls:<br>On/Off switch, Call Sign Select, Grab Image, Send Image, Settings (scrolls menus) |
| Display:   | 5x7 dot alpha-numeric low power green LED's (like cellular phones)<br>One (1) flashing "battery low" LED                             |
| * User Controls & Display are optional for embedded applications (i.e., RIT can be built without them) |  |
| Power:   | 2-4 watts @ full operation (idle mode when not doing imaging portion)  |
| Battery:   | Internal battery and/or external power<br>30 hours idle, 1 hour operational<br>Disposables or Rechargeable (like cellular phone)     |
| Weight:  | 1 pound (plastic) 1.5 pounds (metal)   |
| Size:  | 1" x 4" x 3" (Hand-Held Cellular Size)   |
| Temperature:   | -20° to 50° C  |

System does only one function at a time:

|                    |  |
|--------------------|--|
| Grab image         | one frame at a time  |
| Color demodulation |  |
| Image Compression  | < 5 seconds (to grab, demodulate, and compress)                      |
| Store image ( 40+) | < 1 second per image   |
| Send Image         | 12Kbit line - 15 seconds goal for image xmit; up to 64Kbit comm link |

Modem functions - built in FEC

Remote Control (configure) capability:

- New call signs
- Set compression ratio
- Snap picture
- Retrieve image

# **SECTION 5**

## **DRAWING AND BLOCK DIAGRAM**

Figure 1 - Micro™ Drawing

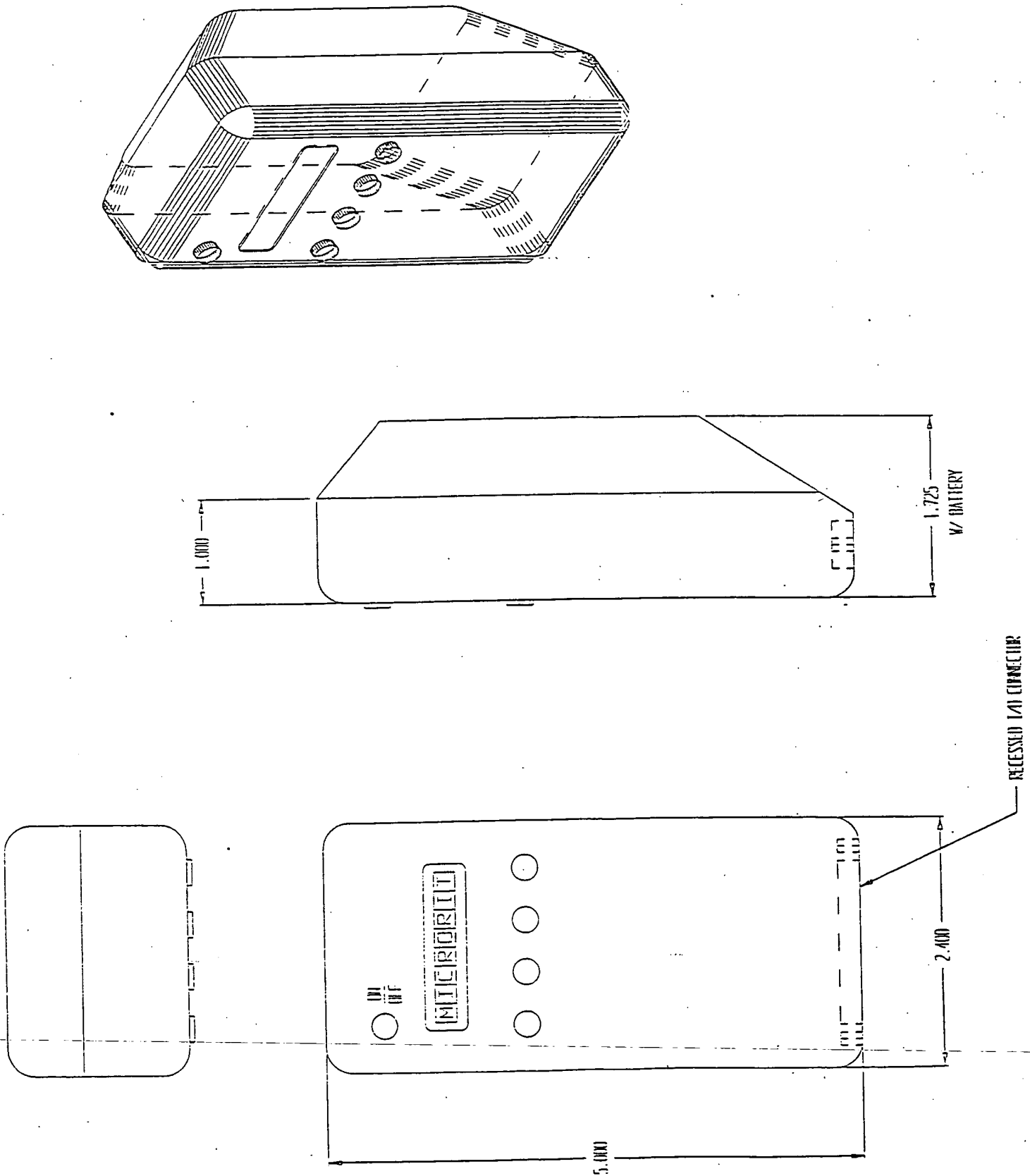
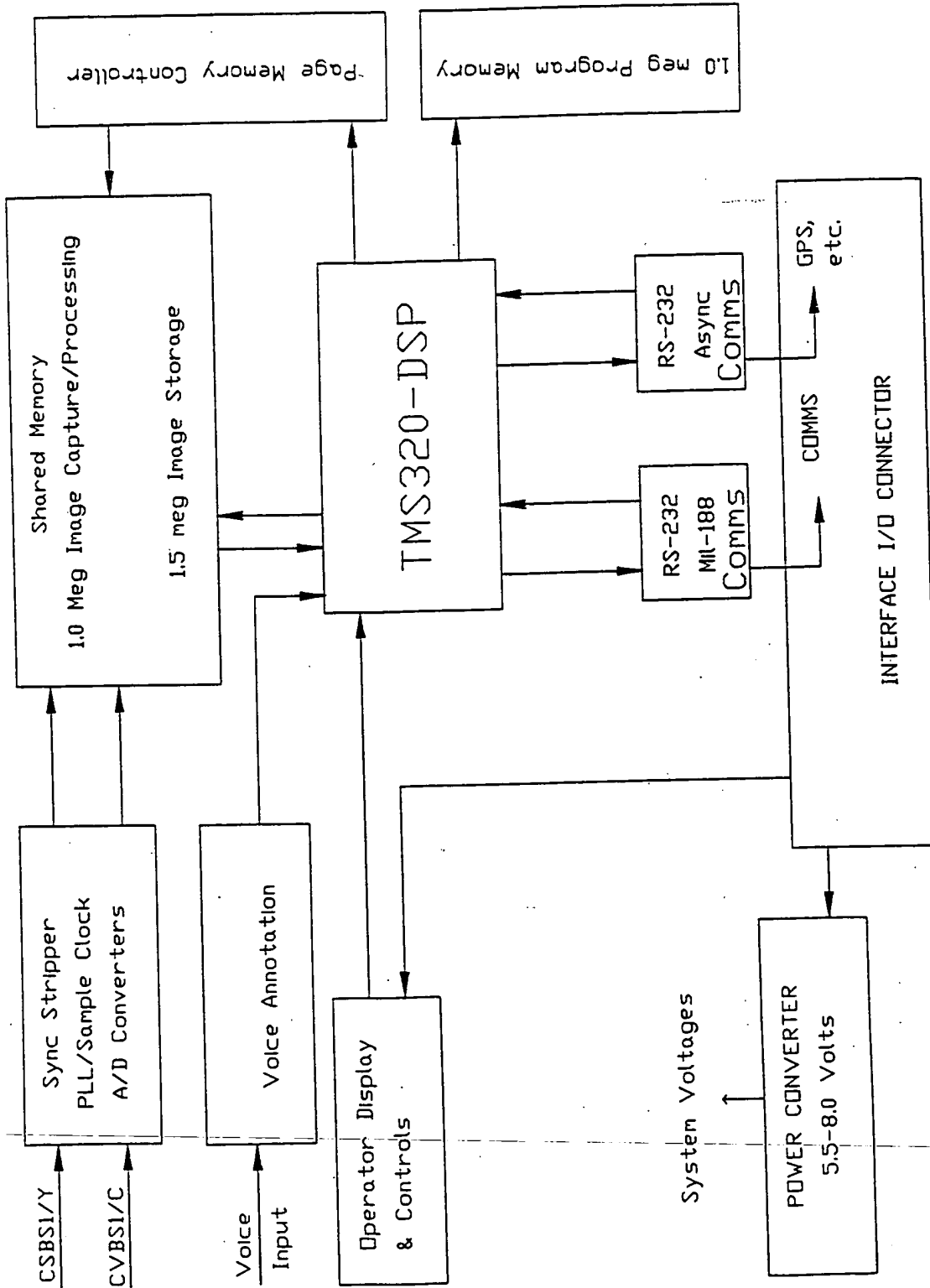

Figure 2 - MicroRIT™ Block Diagram



MICRO-RIT™ BLOCK DIAGRAM





# **SECTION 6**

# **SCHEDULE**

| ID               | Task     | 29 |
|------------------|----------|----|
| 1                | Pro      |    |
| 2                | Wri      |    |
| 3                | Eva      |    |
| 4                | Eva      |    |
| 5                | Eva      |    |
| 6                | DSF      |    |
| 7                | O/S      |    |
| 8                | Orde     |    |
| 9                | Writ     |    |
| 10               | Syst     |    |
| 11               |          |    |
| 12               |          |    |
| 13               |          |    |
| 14               |          |    |
| 15               |          |    |
| 16               |          |    |
| 17               |          |    |
| 18               | Vide     |    |
| 19               |          |    |
| 20               | V        |    |
| 21               | V        |    |
| 22               | F        |    |
| 23               | F        |    |
| 24               | it       |    |
| 25               | Comm     |    |
| 26               | A        |    |
| 27               | S        |    |
| 28               | P        |    |
| 29               | P        |    |
| 30               | Audio    |    |
| 31               | A        |    |
| 32               | A        |    |
| 33               | A        |    |
| 34               | A        |    |
| 35               | User I   |    |
| 36               | LI       |    |
| 37               | Pe       |    |
| 38               | M        |    |
| 39               | Remot    |    |
| 40               | R        |    |
| 41               | D        |    |
| 42               | Hardwa   |    |
| 43               | System   |    |
| 44               | User M   |    |
| 45               | System   |    |
| 46               | Write A  |    |
| 47               | Custom   |    |
| 48               | Montly   |    |
| 61               | Custon   |    |
| 68               | Delivery |    |
| Project: micront |          |    |
| Date: Thu 11/2/9 |          |    |

# MicroRit Hardware Development

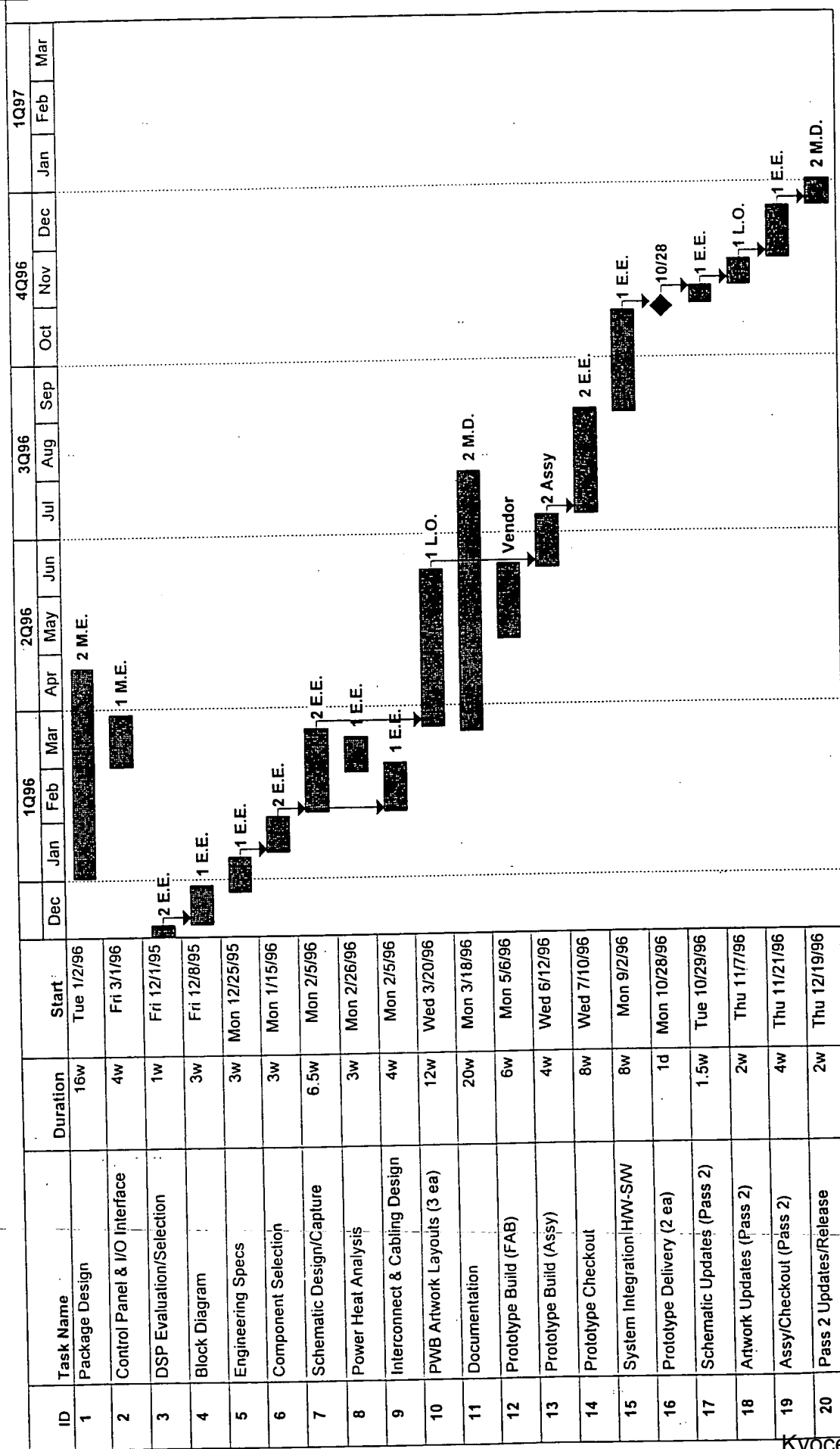

# SECTION 7

## COST DETAIL

MICR. RIT  
PHOTOTELEESIS

Micro-Rit

| Hardware  | Hours   | Rates   | Labor \$  | Materials   | Overhead  | Total Cost   |
|---|---|---|---|-------------|---|--|
| Mechanical design,<br>Packaging<br>Control Panel & I/O Interface  | 1040<br>160   | \$26.62<br>\$27.47  | \$27,684.80<br>\$4,395.20   |             | \$69,212.00<br>\$10,988.00  | \$96,896.80<br>\$15,383.20   |
| Electrical design<br>DSP Evaluation /Selection<br>Block Diagram<br>Engineering Specifications/ Updates<br>Component Selection<br>Power/Heat Analysis<br>Interconnect/Cabling Design<br>Schematic Design/Capture<br>Schematic update Pass2 (3 each)<br>PWB artwork design/layout (3 each)<br>PWB layout Pass 2 (2 each)<br>Documentation | 80<br>120<br>240<br>180<br>120<br>160<br>520<br>80<br>480<br>120<br>800 | \$30.52<br>\$30.52<br>\$30.52<br>\$30.52<br>\$42.19<br>\$26.62<br>\$30.56<br>\$30.56<br>\$22.92<br>\$22.92<br>\$19.53 | \$2,441.60<br>\$3,662.40<br>\$7,324.80<br>\$5,493.60<br>\$5,062.80<br>\$4,259.20<br>\$15,891.20<br>\$2,444.80<br>\$11,001.60<br>\$2,750.40<br>\$15,624.00 |             | \$6,104.00<br>\$9,156.00<br>\$18,312.00<br>\$13,734.00<br>\$12,657.00<br>\$10,648.00<br>\$39,728.00<br>\$6,112.00<br>\$27,504.00<br>\$6,876.00<br>\$39,060.00 | \$8,545.60<br>\$12,818.40<br>\$25,636.80<br>\$19,227.60<br>\$17,719.80<br>\$14,907.20<br>\$55,619.20<br>\$8,556.80<br>\$38,505.60<br>\$9,626.40<br>\$54,684.00 |
| Prototype<br>Assembly /Checkout labor<br>Materials & Fab  | 960   | \$21.93   | \$21,052.80   | \$30,000.00 | \$52,632.00   | \$73,684.80<br>\$30,000.00   |
| H/W Project Management<br>Project review  | 480<br>320  | \$42.19<br>\$42.19  | \$20,251.20<br>\$13,500.80  |             | \$50,628.00<br>\$33,752.00  | \$70,879.20<br>\$47,252.80   |
| Development Equipment<br>DSP Development station<br>DSP Evaluation Kit  | 320<br>160  | \$27.47<br>\$27.47  | \$8,790.40<br>\$4,395.20  | \$15,000.00 | \$21,976.00<br>\$10,988.00  | \$45,766.40<br>\$15,383.20   |
| Total Hardware  | 6340  |   | \$176,026.80  | \$45,000.00 | \$440,067.00  | \$661,093.80   |

MICRO-RIT  
PHOTOTELEESIS

| Software                             | Hours | Rates   | Labor \$    | Materials   | Overhead     | Total Cost   |
|--------------------------------------|-------|---------|-------------|-------------|--------------|--------------|
| Specification Document               | 80    | \$32.81 | \$2,624.80  |             | \$6,562.00   | \$9,186.80   |
| Evaluate and select DSP              | 80    | \$32.81 | \$2,624.80  |             | \$6,562.00   | \$9,186.80   |
| Evaluate and Select Operating system | 170   | \$31.51 | \$5,356.70  |             | \$13,391.75  | \$18,748.45  |
| Evaluate and Select Compiler         | 170   | \$31.51 | \$5,356.70  |             | \$13,391.75  | \$18,748.45  |
| Other Development O/S compiler       |       |         |             | \$15,000.00 | \$0.00       | \$15,000.00  |
| Software Specification               | 170   | \$32.81 | \$5,577.70  |             | \$13,944.25  | \$19,521.95  |
| System Management Functions          |       |         |             |             |              |              |
| Memory Management Routines           | 320   | \$30.21 | \$9,667.20  |             | \$24,168.00  | \$33,835.20  |
| Code Space Manager                   | 320   | \$32.81 | \$10,499.20 |             | \$26,248.00  | \$36,747.20  |
| Data Space Manager                   | 160   | \$25.00 | \$4,000.00  |             | \$10,000.00  | \$14,000.00  |
| Refresh Interface                    | 160   | \$32.81 | \$5,249.60  |             | \$13,124.00  | \$18,373.60  |
| Interrupt Handling                   | 320   | \$25.00 | \$8,000.00  |             | \$20,000.00  | \$28,000.00  |
| Power Management                     |       |         |             |             |              |              |
| Video System                         | 420   | \$28.91 | \$12,140.10 |             | \$30,350.25  | \$42,490.35  |
| Video Frame Grabber S/W              | 160   | \$32.81 | \$5,249.60  |             | \$13,124.00  | \$18,373.60  |
| Video Demodulation S/W S-Video       | 160   | \$32.81 | \$5,249.60  |             | \$13,124.00  | \$18,373.60  |
| Video Demodulation S/W Composite     | 240   | \$32.81 | \$7,874.40  |             | \$19,686.00  | \$27,560.40  |
| Port Wavelet compressor              | 240   | \$25.00 | \$6,000.00  |             | \$15,000.00  | \$21,000.00  |
| Port JPEG compressor                 | 80    | \$30.21 | \$2,416.80  |             | \$6,042.00   | \$8,458.80   |
| Image Storage Handler                |       |         |             |             |              |              |
| Communications System                | 60    | \$25.00 | \$1,500.00  |             | \$3,750.00   | \$5,250.00   |
| Asynch Port Interface                | 120   | \$25.00 | \$3,000.00  |             | \$7,500.00   | \$10,500.00  |
| Synch Port Interface                 | 1650  | \$28.91 | \$47,693.25 |             | \$119,233.13 | \$166,926.38 |
| Port PTAC                            | 240   | \$25.00 | \$6,000.00  |             | \$15,000.00  | \$21,000.00  |
| Port PTAC-2                          | 545   | \$32.64 | \$17,791.00 |             | \$44,477.50  | \$62,268.50  |
| Audio System                         | 160   | \$30.21 | \$4,833.60  |             | \$12,084.00  | \$16,917.60  |
| User Interface                       | 60    | \$25.00 | \$1,500.00  |             | \$3,750.00   | \$5,250.00   |
| LED Display Driver                   | 60    | \$25.00 | \$1,500.00  |             | \$3,750.00   | \$5,250.00   |
| Push Button Interface                | 120   | \$25.00 | \$3,000.00  |             | \$7,500.00   | \$10,500.00  |
| Menuing Interface                    |       |         |             |             |              |              |
| Remote Control/Host Mode             | 480   | \$30.21 | \$14,500.80 |             | \$36,252.00  | \$50,752.80  |
| Remote Control Interface             | 320   | \$30.21 | \$9,667.20  |             | \$24,168.00  | \$33,835.20  |
| Docking Station Interface            |       |         |             |             |              |              |

CONFIDENTIAL DATA

MICRO-RIT  
PHOTOTELEESIS

|  | Hours   | Rates   | Labor \$     | Materials   | Overhead       | Total Cost     |
|--|---------|---------|--------------|-------------|----------------|----------------|
| Software                                 | 1200    | \$28.26 | \$33,906.00  |             | \$84,765.00    | \$118,671.00   |
| System Integration                       | 280     | \$21.10 | \$5,906.60   |             | \$14,766.50    | \$20,673.10    |
| User Manuals                             | 475     | \$25.72 | \$12,217.30  |             | \$30,543.24    | \$42,760.54    |
| System Checkout & rework                 | 120     | \$38.91 | \$4,668.60   |             | \$11,671.50    | \$16,340.10    |
| Write acceptance test plan               | 14      | \$45.84 | \$641.76     |             | \$1,604.40     | \$2,246.16     |
| Customer Acceptance test Plan Management | 277.2   | \$38.91 | \$10,784.47  |             | \$26,961.17    | \$37,745.63    |
| Total Software                           | 9431.2  |         | \$276,997.77 | \$15,000.00 | \$692,494.43   | \$984,492.21   |
| Combined                                 | 15771.2 |         | \$453,024.57 | \$60,000.00 | \$1,132,561.43 | \$1,645,586.01 |

# SECTION 8

## PERSONNEL RESUMES



## **BRUCE C. MATHER**

Manager of Software Engineering  
PhotoTelesis...a business of Texas Instruments Incorporated

Dr. Mather joined PhotoTelesis Corporation in December 1993, as Director of Software Engineering. Prior to joining PhotoTelesis, he was a Senior Research Engineer at Southwest Research Institute where he was employed for seven years. He also serves as an Adjunct Professor at St. Mary's University where he teaches a course in Digital Speech Processing.

Among Dr. Mather's technical areas of expertise are robotic systems, image processing, machine perception, neural networks, virtual reality, multimedia database systems and digital signal processing. He is a member of the Institute of Electrical and Electronic Engineers (IEEE), the Society of Manufacturing Engineers (SME), and the International Neural Network Society (INNS).

Dr. Mather attended the University of Illinois in Champaign, Urbana, where he earned his BSEE degree in 1980, his MSEE in 1983, and his PhD in Electrical Engineering in 1986. He graduated with highest honors and received the Eta Kappa Nu Senior Honor Award for academic excellence. His PhD dissertation involved advanced, multidimensional digital signal processing (DSP) of synthetic aperture radar (SAR) data.

At Southwest Research Institute, while working in their Advanced Robotics Department, he designed and developed interprocess and intercomputer communication and synchronization in the C programming language under the Unix operating system.

In 1991, Bruce joined the Advanced Training Concepts Section at SWRI and was instrumental in the development of the Visual Information System multimedia database product which runs under Windows 3.1. He also worked on an IR&D project involving a Virtual Environment system for multidimensional data visualization. His other areas of interest include speech recognition, position sensing, and holographic sound.

## ROGER D. VEST

Manager of Hardware Engineering  
PhotoTelesis...a business of Texas Instruments Incorporated

Mr. Vest joined PhotoTelesis Corporation in January of 1994 as Director of Hardware Engineering. Previously, he was Manager of Engineering for CompuAdd Express Corporation in Austin, Texas. In that position, he reported to the President and was responsible for all phases of product development and product sourcing. During his time there, three portable computer (notebook) products were introduced.

Prior to CompuAdd Express, Mr. Vest was employed by Texas Instruments, also in Austin, for over fifteen years. When he resigned to accept the CompuAdd Express position, he was a Senior Member of the Technical Staff. During his last year with TI, Mr. Vest managed a PWB design/layout center for their Custom Manufacturing Group. This effort included initial layout, prototype PWB fabrication, PWB assembly, and prototype checkout of customer products for several high volume computer suppliers. He has an extensive background in surface-mount technology, including footprint design, PWB layout guidelines and automatic test compatibility. He has published several articles on surface-mount technology design rules and footprint requirements.

Mr. Vest graduated from Texas Tech University in Lubbock, Texas, with a Bachelor of Science degree in Electrical Engineering. He was on the Dean's list at the time of his graduation.

## WILLIAM A. KIDD

Program Manager

PhotoTelesis...a business of Texas Instruments Incorporated

Mr. Kidd joined Texas Instruments in June 1988. While assigned to the Airborne department of the Defense Systems and Electronics Group, Mr. Kidd was a member of the Light Helicopter program where he was the Program Control manager and cost account manager for several hundred data item submittals. Follow-on assignments included management support to numerous projects. Most recently Mr. Kidd was transferred to PhotoTelesis, a business of Texas Instruments, where he was assigned the program management responsibility for the U.S. Army's Light Weight Video Reconnaissance System (LVRS).

Mr. Kidd developed an excellent understanding of DoD acquisition while on active duty with the U.S. Air Force from 1967-1988. During his military career he gained more than 20 years direct experience in DoD Systems Acquisition Management. At the time of his retirement, Mr. Kidd was the Commander of Air Force Systems Command's, Systems Acquisition School. Previous Air Force program management assignments included the Pave Tack Pod program, the Pave Tack Forward Looking Infrared (FLIR) subsystem, and the Pave Tiger Mini-Drone program. Other relevant Air Force assignments include schedule planning and control for launch, on-orbit support, and recovery of satellite payloads, and Air Force Plant Representative Officer at a defense contractor's facility, responsible for on-site engineering management of DEM/VAL and production programs.

Mr. Kidd has an MS degree in Engineering Management from Arizona State University, Tempe, AZ. His undergraduate BS degree in Mechanical Engineering, was received from Grove City College, Grove City, PA.





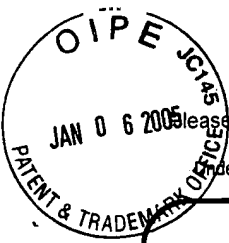

1fw \$2622

Please type a plus sign (+) inside this box →

Approved for use through 10/31/2002. OMB 0651-0031  
 U.S. Patent and Trademark Office: U.S. DEPARTMENT OF COMMERCE  
 Under the Paperwork Reduction Act of 1995, no persons are required to respond to a collection of information unless it displays a valid OMB control number.

|  |                             |                               |                 |
|--|-----------------------------|-------------------------------|-----------------|
| <b>TRANSMITTAL FORM</b><br><i>(to be used for all correspondence after initial filing)</i> | <b>Application Number</b>   | 10/336,470                    |                 |
|  | <b>Filing Date</b>          | January 13, 2003              |                 |
|  | <b>First Named Inventor</b> | David A. Monroe               |                 |
|  | <b>Group Art Unit</b>       | 2622                          |                 |
|  | <b>Examiner Name</b>        | Joseph P. Pokrzywa            |                 |
| <b>Total Number of Pages in This Submission</b>  | 134                         | <b>Attorney Docket Number</b> | 121817.0002.042 |

| ENCLOSURES (check all that apply)   |   |   |
|---|---|---|
| <input checked="" type="checkbox"/> Fee Transmittal Form<br><input type="checkbox"/> Fee Attached<br><input checked="" type="checkbox"/> Amendment / Response<br><input type="checkbox"/> After Final<br><input checked="" type="checkbox"/> Affidavits/declaration(s)<br><input checked="" type="checkbox"/> Extension of Time Request<br><input type="checkbox"/> Express Abandonment Request<br><input type="checkbox"/> Information Disclosure Statement<br><input type="checkbox"/> Certified Copy of Priority Document(s)<br><input type="checkbox"/> Response to Missing Parts/ Incomplete Application<br><input type="checkbox"/> Response to Missing Parts under 37 CFR 1.52 or 1.53 | <input type="checkbox"/> Assignment Papers (for an Application)<br><input checked="" type="checkbox"/> Drawing(s)<br><input type="checkbox"/> Licensing-related Papers<br><input type="checkbox"/> Petition<br><input type="checkbox"/> Petition to Convert to a Provisional Application<br><input type="checkbox"/> Power of Attorney, Revocation Change of Correspondence Address<br><input type="checkbox"/> Terminal Disclaimer<br><input type="checkbox"/> Request for Refund<br><input type="checkbox"/> CD, Number of CD(s) ____ | <input type="checkbox"/> After Allowance Communication to Group<br><input type="checkbox"/> Appeal Communication to Board of Appeals and Interferences<br><input type="checkbox"/> Appeal Communication to Group (Appeal Notice, Brief, Reply Brief)<br><input type="checkbox"/> Proprietary Information<br><input type="checkbox"/> Status Letter<br><input checked="" type="checkbox"/> Other Enclosure(s) (please identify below):<br><p style="text-align: center;"><b>Index and 17 Exhibits included therein; and Acknowledgement Postcard</b></p> |
| Remarks   |   |   |

| SIGNATURE OF APPLICANT, ATTORNEY, OR AGENT |  |
|--|--|
| Firm or Individual name                    | Robert C. Curfiss<br>Jackson Walker L.L.P. |
| Signature                                  |  |
| Date                                       | January 3, 2005                            |

| CERTIFICATE OF MAILING   |               |      |                 |
|--|---------------|------|-----------------|
| I hereby certify that this correspondence is being deposited with the United States Postal Service as first class mail in an envelope addressed to: Commissioner for Patents, P.O. Box 1450, Alexandria, VA. 22313-1450: <span style="border: 1px solid black; padding: 2px;">January 3, 2005</span> |               |      |                 |
| Typed or printed name  | Renee Treider |      |                 |
| Signature  |               | Date | January 3, 2005 |

**Burden Hour Statement:** This form is estimated to take 0.2 hours to complete. Time will vary depending upon the needs of the individual case. Any comments on the amount of time you are required to complete this form should be sent to the Chief Information Officer, U.S. Patent and Trademark Office, Washington, DC 20231. DO NOT SEND FEES OR COMPLETED FORMS TO THIS ADDRESS. SEND TO: Assistant Commissioner for Patents, Washington, DC 20231.

JAN 06 2005  
 PATENT & TRADEMARK OFFICE

# FEE TRANSMITTAL for FY 2004

Effective 10/01/2003. Patent fees are subject to annual revision.

Applicant claims small entity status. See 37 CFR 1.27

TOTAL AMOUNT OF PAYMENT (\$) 670.00

Complete if Known

|                      |                    |
|----------------------|--------------------|
| Application Number   | 10/336,470         |
| Filing Date          | January 3, 2003    |
| First Named Inventor | David A. Monroe    |
| Examiner Name        | Joseph P. Pokrzywa |
| Art Unit             | 2622               |
| Attorney Docket No.  | 121817.0002.042    |

**METHOD OF PAYMENT (check all that apply)**

Check  Credit card  Money Order  Other  None

Deposit Account:

Deposit Account Number: 50-3322

Deposit Account Name: Constant & Vela

The Director is authorized to: (check all that apply)

Charge fee(s) indicated below  Credit any overpayments

Charge any additional fee(s) during the pendency of this application

Charge fee(s) indicated below, except for the filing fee to the above-identified deposit account.

**FEE CALCULATION**

**1. BASIC FILING FEE**

| Large Entity | Small Entity | Fee Code | Fee (\$) | Fee Description        | Fee Paid |
|--------------|--------------|----------|----------|------------------------|----------|
|              |              | 1001     | 770      | Utility filing fee     |          |
|              |              | 1002     | 340      | Design filing fee      |          |
|              |              | 1003     | 530      | Plant filing fee       |          |
|              |              | 1004     | 770      | Reissue filing fee     |          |
|              |              | 1005     | 160      | Provisional filing fee |          |
| SUBTOTAL (1) |              |          |          |                        | (\$)     |

**2. EXTRA CLAIM FEES FOR UTILITY AND REISSUE**

Total Claims: 62 -20\*\* = 7 Extra Claims X 50 Fee from below = 350 Fee Paid

Independent Claims: 4 -3\*\* = 1 X 200 = 200

Multiple Dependent: X = 0

| Large Entity | Small Entity | Fee Code | Fee (\$) | Fee Description  | Fee Paid    |
|--------------|--------------|----------|----------|--|-------------|
|              |              | 1202     | 18       | Claims in excess of 20                                     |             |
|              |              | 1201     | 86       | Independent claims in excess of 3                          |             |
|              |              | 1203     | 290      | Multiple dependent claim, if not paid                      |             |
|              |              | 1204     | 86       | ** Reissue independent claims over original patent         |             |
|              |              | 1205     | 18       | ** Reissue claims in excess of 20 and over original patent |             |
| SUBTOTAL (2) |              |          |          |  | (\$) 550.00 |

\*\*or number previously paid, if greater. For Reissues, see above

**3. ADDITIONAL FEES**

| Large Entity                      | Small Entity | Fee Code | Fee (\$) | Fee Description  | Fee Paid                |
|-----------------------------------|--------------|----------|----------|--|-------------------------|
|                                   |              | 1051     | 130      | 2051 65 Surcharge - late filing fee or oath  |                         |
|                                   |              | 1052     | 50       | 2052 25 Surcharge - late provisional filing fee or cover sheet.                    |                         |
|                                   |              | 1053     | 130      | 1053 130 Non-English specification   |                         |
|                                   |              | 1812     | 2,520    | 1812 2,520 For filing a request for reexamination                                  |                         |
|                                   |              | 1804     | 920*     | 1804 920* Requesting publication of SIR prior to Examiner action                   |                         |
|                                   |              | 1805     | 1,840*   | 1805 1,840* Requesting publication of SIR after Examiner action                    |                         |
|                                   |              | 1251     | 110      | 2251 55 Extension for reply within first month                                     | 120.00                  |
|                                   |              | 1252     | 420      | 2252 210 Extension for reply within second month                                   |                         |
|                                   |              | 1253     | 950      | 2253 475 Extension for reply within third month                                    |                         |
|                                   |              | 1254     | 1,480    | 2254 740 Extension for reply within fourth month                                   |                         |
|                                   |              | 1255     | 2,010    | 2255 1,005 Extension for reply within fifth month                                  |                         |
|                                   |              | 1401     | 330      | 2401 165 Notice of Appeal  |                         |
|                                   |              | 1402     | 330      | 2402 165 Filing a brief in support of an appeal                                    |                         |
|                                   |              | 1403     | 290      | 2403 145 Request for oral hearing  |                         |
|                                   |              | 1451     | 1,510    | 1451 1,510 Petition to institute a public use proceeding                           |                         |
|                                   |              | 1452     | 110      | 2452 55 Petition to revive - unavoidable   |                         |
|                                   |              | 1453     | 1,330    | 2453 665 Petition to revive - unintentional  |                         |
|                                   |              | 1501     | 1,330    | 2501 665 Utility issue fee (or reissue)  |                         |
|                                   |              | 1502     | 480      | 2502 240 Design issue fee  |                         |
|                                   |              | 1503     | 640      | 2503 320 Plant issue fee   |                         |
|                                   |              | 1460     | 130      | 1460 130 Petitions to the Commissioner   |                         |
|                                   |              | 1807     | 50       | 1807 50 Processing fee under 37 CFR 1.17 (q)                                       |                         |
|                                   |              | 1806     | 180      | 1806 180 Submission of Information Disclosure Stmt                                 |                         |
|                                   |              | 8021     | 40       | 8021 40 Recording each patent assignment per property (times number of properties) |                         |
|                                   |              | 1809     | 770      | 2809 385 Filing a submission after final rejection (37 CFR § 1.129(a))             |                         |
|                                   |              | 1810     | 770      | 2810 385 For each additional invention to be examined (37 CFR § 1.129(b))          |                         |
|                                   |              | 1801     | 770      | 2801 385 Request for Continued Examination (RCE)                                   |                         |
|                                   |              | 1802     | 900      | 1802 900 Request for expedited examination of a design application                 |                         |
| Other fee (specify) _____         |              |          |          |  |                         |
| *Reduced by Basic Filing Fee Paid |              |          |          |  | SUBTOTAL (3) (\$120.00) |

**SUBMITTED BY** Complete (if applicable)

Name (Print/Type): Robert C. Curfiss Registration No. (Attorney/Agent): 26,540 Telephone: 713-752-4322

Signature: [Signature] Date: January 3, 2005

**WARNING: Information on this form may become public. Credit card information should not be included on this form. Provide credit card information and authorization on PTO-2038.**

This collection of information is required by 37 CFR 1.17 and 1.27. The information is required to obtain or retain a benefit by the public which is to file (and by the USPTO to process) an application. Confidentiality is governed by 35 U.S.C. 122 and 37 CFR 1.14. This collection is estimated to take 12 minutes to complete, including gathering, preparing, and submitting the completed application form to the USPTO. Time will vary depending upon the individual case. Any comments on the amount of time you require to complete this form and/or suggestions for reducing this burden, should be sent to the Chief Information Officer, U.S. Patent and Trademark Office, U.S. Department of Commerce, P.O. Box 1450, Alexandria, VA 22313-1450. DO NOT SEND FEES OR COMPLETED FORMS TO THIS ADDRESS. SEND TO: Commissioner for Patents, P.O. Box 1450, Alexandria, VA 22313-1450.

If you need assistance in completing this form, call 1-800-PTO-9199 (1-800-786-9199) and select option 2.

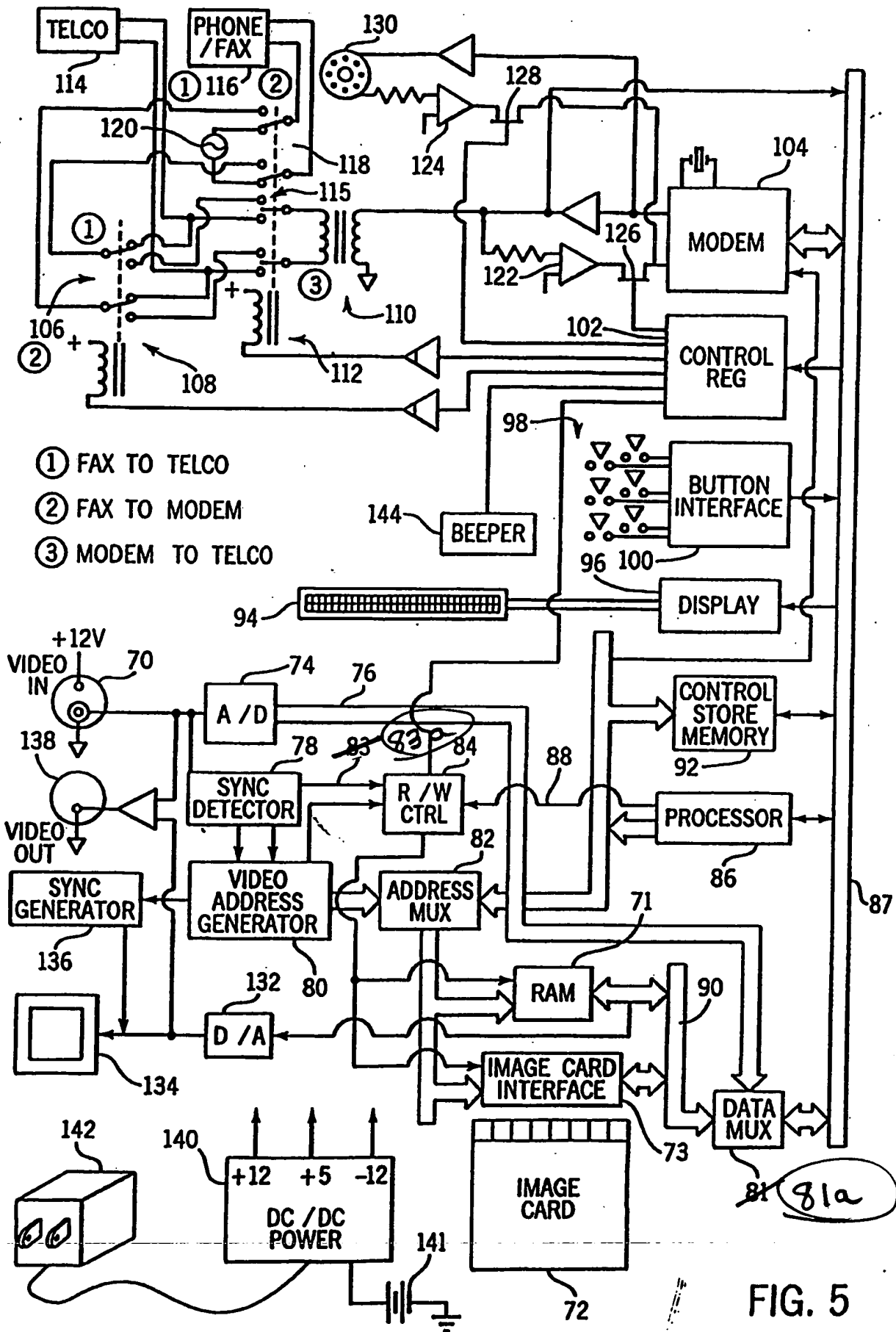

FIG. 5





UNITED STATES PATENT AND TRADEMARK OFFICE

UNITED STATES DEPARTMENT OF COMMERCE  
United States Patent and Trademark Office  
Address: COMMISSIONER FOR PATENTS  
P.O. Box 1450  
Alexandria, Virginia 22313-1450  
www.uspto.gov

| APPLICATION NO. | FILING DATE | FIRST NAMED INVENTOR | ATTORNEY DOCKET NO. | CONFIRMATION NO. |
|-----------------|-------------|----------------------|---------------------|------------------|
| 10/336,470      | 01/03/2003  | David A. Monroe      | 121817.0002.042     | 8448             |

7590 09/27/2004  
Robert C Curfiss  
JACKSON WALKER L.L.P.  
112 E. Pecan Street, Suite 2100  
San Antonio, TX 78205

EXAMINER

POKRZYWA, JOSEPH R

ART UNIT PAPER NUMBER

2622

DATE MAILED: 09/27/2004

Please find below and/or attached an Office communication concerning this application or proceeding.

|                              |                                       |   |  |
|------------------------------|---------------------------------------|---|--|
| <b>Office Action Summary</b> | <b>Application No.</b><br>10/336,470  | <b>Applicant(s)</b><br>MONROE, DAVID A. |  |
|                              | <b>Examiner</b><br>Joseph R. Pokrzywa | <b>Art Unit</b><br>2622                 |  |

-- The MAILING DATE of this communication appears on the cover sheet with the correspondence address --

**Period for Reply**

A SHORTENED STATUTORY PERIOD FOR REPLY IS SET TO EXPIRE 3 MONTH(S) FROM THE MAILING DATE OF THIS COMMUNICATION.

- Extensions of time may be available under the provisions of 37 CFR 1.136(a). In no event, however, may a reply be timely filed after SIX (6) MONTHS from the mailing date of this communication.
- If the period for reply specified above is less than thirty (30) days, a reply within the statutory minimum of thirty (30) days will be considered timely.
- If NO period for reply is specified above, the maximum statutory period will apply and will expire SIX (6) MONTHS from the mailing date of this communication.
- Failure to reply within the set or extended period for reply will, by statute, cause the application to become ABANDONED (35 U.S.C. § 133). Any reply received by the Office later than three months after the mailing date of this communication, even if timely filed, may reduce any earned patent term adjustment. See 37 CFR 1.704(b).

**Status**

- 1)  Responsive to communication(s) filed on \_\_\_\_.
- 2a)  This action is **FINAL**.                      2b)  This action is non-final.
- 3)  Since this application is in condition for allowance except for formal matters, prosecution as to the merits is closed in accordance with the practice under *Ex parte Quayle*, 1935 C.D. 11, 453 O.G. 213.

**Disposition of Claims**

- 4)  Claim(s) 1-42 is/are pending in the application.  
    4a) Of the above claim(s) \_\_\_\_ is/are withdrawn from consideration.
- 5)  Claim(s) \_\_\_\_ is/are allowed.
- 6)  Claim(s) 1-42 is/are rejected.
- 7)  Claim(s) \_\_\_\_ is/are objected to.
- 8)  Claim(s) \_\_\_\_ are subject to restriction and/or election requirement.

**Application Papers**

- 9)  The specification is objected to by the Examiner.
- 10)  The drawing(s) filed on 14 July 2003 is/are: a)  accepted or b)  objected to by the Examiner.  
    Applicant may not request that any objection to the drawing(s) be held in abeyance. See 37 CFR 1.85(a).  
    Replacement drawing sheet(s) including the correction is required if the drawing(s) is objected to. See 37 CFR 1.121(d).
- 11)  The oath or declaration is objected to by the Examiner. Note the attached Office Action or form PTO-152.

**Priority under 35 U.S.C. § 119**

- 12)  Acknowledgment is made of a claim for foreign priority under 35 U.S.C. § 119(a)-(d) or (f).  
    a)  All    b)  Some \*    c)  None of:
1.  Certified copies of the priority documents have been received.
  2.  Certified copies of the priority documents have been received in Application No. \_\_\_\_\_.
  3.  Copies of the certified copies of the priority documents have been received in this National Stage application from the International Bureau (PCT Rule 17.2(a)).
- \* See the attached detailed Office action for a list of the certified copies not received.

**Attachment(s)**

- |  |   |
|--|---|
| 1) <input type="checkbox"/> Notice of References Cited (PTO-892)   | 4) <input type="checkbox"/> Interview Summary (PTO-413)<br>Paper No(s)/Mail Date. _____ |
| 2) <input type="checkbox"/> Notice of Draftsperson's Patent Drawing Review (PTO-948)   | 5) <input type="checkbox"/> Notice of Informal Patent Application (PTO-152)             |
| 3) <input checked="" type="checkbox"/> Information Disclosure Statement(s) (PTO-1449 or PTO/SB/08)<br>Paper No(s)/Mail Date <u>1/20/04</u> . | 6) <input type="checkbox"/> Other: _____  |

## DETAILED ACTION

### *Information Disclosure Statement*

1. The references listed in the Information Disclosure Statement submitted on 1/20/04 have been considered by the examiner (see attached PTO-1449).

### *Specification*

2. The disclosure is objected to because of the following informalities:  
in paragraph 0051, line 13, PCMCIA card 50” should read PCMCIA card 72”.

Appropriate correction is required.

### *Drawings*

3. The drawings are objected to as failing to comply with 37 CFR 1.84(p)(4) because reference character “81” has been used to designate both the hardwired personal computer in Fig. 4 and the data multiplexer circuit in Fig. 5, and reference character "83" has been used to designate both the communications interface module in Fig. 4 and the sync signal in Fig. 5. Corrected drawing sheets in compliance with 37 CFR 1.121(d) are required in reply to the Office action to avoid abandonment of the application. Any amended replacement drawing sheet should include all of the figures appearing on the immediate prior version of the sheet, even if only one figure is being amended. The replacement sheet(s) should be labeled “Replacement Sheet” in the page header (as per 37 CFR 1.84(c)) so as not to obstruct any portion of the drawing figures. If the changes are not accepted by the examiner, the applicant will be notified and informed of any

Art Unit: 2622

required corrective action in the next Office action. The objection to the drawings will not be held in abeyance.

4. The drawings are objected to as failing to comply with 37 CFR 1.84(p)(5) because they do not include the following reference sign(s) mentioned in the description: reference numeral "29", in paragraph 0049, line 18. Corrected drawing sheets in compliance with 37 CFR 1.121(d) are required in reply to the Office action to avoid abandonment of the application. Any amended replacement drawing sheet should include all of the figures appearing on the immediate prior version of the sheet, even if only one figure is being amended. The replacement sheet(s) should be labeled "Replacement Sheet" in the page header (as per 37 CFR 1.84(c)) so as not to obstruct any portion of the drawing figures. If the changes are not accepted by the examiner, the applicant will be notified and informed of any required corrective action in the next Office action. The objection to the drawings will not be held in abeyance.

5. The drawings are objected to because in Fig. 4, PC modem protocol box "66" should read "68", as read in paragraph 0053, lines 20 and 21. Corrected drawing sheets in compliance with 37 CFR 1.121(d) are required in reply to the Office action to avoid abandonment of the application. Any amended replacement drawing sheet should include all of the figures appearing on the immediate prior version of the sheet, even if only one figure is being amended. The figure or figure number of an amended drawing should not be labeled as "amended." If a drawing figure is to be canceled, the appropriate figure must be removed from the replacement sheet, and where necessary, the remaining figures must be renumbered and appropriate changes made to the brief description of the several views of the drawings for consistency. Additional replacement sheets may be necessary to show the renumbering of the remaining figures. The replacement

Art Unit: 2622

sheet(s) should be labeled "Replacement Sheet" in the page header (as per 37 CFR 1.84(c)) so as not to obstruct any portion of the drawing figures. If the changes are not accepted by the examiner, the applicant will be notified and informed of any required corrective action in the next Office action. The objection to the drawings will not be held in abeyance.

### *Claim Objections*

6. **Claims 3 and 5** are objected to because of the following informalities:

In *claim 3*, line 1, "claim 1" should read "claim 2", as reference is made to "said memory", introduced in claim 2;

In *claim 5*, line 1, "claim 1" should read "claim 4", as reference is made to "the digital signal", introduced in claim 4.

Appropriate correction is required.

### *Claim Rejections - 35 USC § 102*

7. The following is a quotation of the appropriate paragraphs of 35 U.S.C. 102 that form the basis for the rejections under this section made in this Office action:

A person shall be entitled to a patent unless –

(b) the invention was patented or described in a printed publication in this or a foreign country or in public use or on sale in this country, more than one year prior to the date of application for patent in the United States.

(e) the invention was described in (1) an application for patent, published under section 122(b), by another filed in the United States before the invention by the applicant for patent or (2) a patent granted on an application for patent by another filed in the United States before the invention by the applicant for patent, except that an international application filed under the treaty defined in section 351(a) shall have the effects for purposes of this subsection of an application filed in the United States only if the international application designated the United States and was published under Article 21(2) of such treaty in the English language.

Art Unit: 2622

8. **Claims 1, 2, 4-12, 21, 23-27, and 30-36** are rejected under 35 U.S.C. 102(b) as being anticipated by Hassan *et al.* (U.S. Patent Number 5,550,646, cited in the Information Disclosure Statement dated 1/20/04).

Regarding **claim 1**, Hassan discloses a self-contained image processing system (device 110 in Figs. 1 and 2) for capturing a visual image and transmitting it to a remote receiving station (see abstract, column 1, lines 47 through 52, column 2, lines 43 through 61, and column 3, lines 10 through 20), with the system comprising an image capture device (CCD 203, column 3, lines 21 through 67), a processor (microcontroller 205) for generating a data signal representing the image (column 3, lines 21 through 67), a communications device (facsimile interface 219) adapted for transmitting the data signal to the remote receiving station (column 4, line 65 through column 5, line 9), and a wireless transmission system between the communications device and the compatible receiving station (column 2, lines 4 through 54, and column 3, lines 10 through 20, with the fax modem 240, being “applied as an input to the transmitter section of a cellular telephone”, as read in column 5, lines 7 through 9).

Regarding **claim 2**, Hassan discloses the system discussed above in claim 1, and further teaches of a memory for receiving and storing the data signal (RAM 207), and wherein the communications device is adapted for recalling the stored data signal from memory (column 4, lines 24 through 64).

Regarding **claim 4**, Hassan discloses the system discussed above in claim 1, and further teaches of the image capture device is an analog camera (lens assembly 201 on a CCD 203) for generating an analog image signal (column 3, lines 21 through 67), and there is further included

Art Unit: 2622

an analog to digital converter for converting the analog image signal to a digital signal (column 3, line 47 through column 4, line 67).

Regarding *claim 5*, Hassan discloses the system discussed above in claim 4 (as understood by the examiner), and further teaches of a subprocessor for generating a Group-III facsimile compatible signal representing the digital signal (column 4, line 65 through column 5, line 9).

Regarding *claim 6*, Hassan discloses the system discussed above in claim 1, and further teaches that the subprocessor comprises a gray scale bit map, a halftone converter, and a binary bit map (see abstract, column 1, lines 54 through 63, and column 3, lines 47 through 67).

Regarding *claim 7*, Hassan discloses the system discussed above in claim 1, and further teaches of an integrated wireless telephone associated with the communications device (column 2, lines 4 through 54).

Regarding *claim 8*, Hassan discloses the system discussed above in claim 1, and further teaches of a housing for housing all of the elements of the system in an integrated body (column 2, lines 39 through 66).

Regarding *claim 9*, Hassan discloses the system discussed above in claim 1, and further teaches that the image capture device is a digital camera (column 2, lines 39 through 67, and column 3, lines 21 through 46).

Regarding *claim 10*, Hassan discloses the system discussed above in claim 1, and further teaches of a view screen for viewing the captured and stored image (LCD display 215, column 4, lines 19 through 64).

Art Unit: 2622

Regarding *claim 11*, Hassan discloses the system discussed above in claim 5, and further teaches of a facsimile receiving device associated locally with the system for providing a local printer for reproducing the captured image in hard copy (column 2, line 66 through column 3, line 4, and column 4, line 65 through column 5, line 22).

Regarding *claim 12*, Hassan discloses the system discussed above in claim 1, and further teaches that the processor is adapted for generating a signal in any of a plurality of selected protocols and wherein the communications device is adapted for transmitting the signal in the proper protocol to a remote, compatible receiving station (column 4, line 65 through column 5, line 10).

Regarding *claim 21*, Hassan discloses the system discussed above in claim 1, and further teaches that the system is of modular construction (see Fig. 2), and the camera (CCD 203), the processor (microcontroller 205), and the communications device (fax interface 219) are each independent, functional units (column 3, line 21 through column 5, line 9) which may be coupled to one another for defining the assembled system (see Fig. 2).

Regarding *claim 23*, Hassan discloses the system discussed above in claim 1, and further teaches of a data processor for creating a text data signal associated with the image data signal (column 4, lines 19 through 64).

Regarding *claim 24*, Hassan discloses the system discussed above in claim 23, and further teaches of an input device for providing text data to the data processor (keypad 211, column 4, lines 1 through 64).

Regarding *claim 25*, Hassan discloses the system discussed above in claim 24, and further teaches that the input device is user controlled (column 4, lines 1 through 64).



Art Unit: 2622

Regarding **claim 26**, Hassan discloses the system discussed above in claim 25, and further teaches that the user controlled input device is an integral keyboard (keypad 211, column 4, lines 1 through 18).

Regarding **claim 27**, Hassan discloses the system discussed above in claim 24, and further teaches that the input device comprises a real time clock (column 4, lines 24 through 42).

Regarding **claim 30**, Hassan discloses the system discussed above in claim 2, and further teaches that the image data signal is stored in a compressed format (column 3, lines 47 through 54).

Regarding **claim 31**, Hassan discloses the system discussed above in claim 2, and further teaches that the image data signal is stored in a half-tone format (column 3, lines 37 through 67).

Regarding **claim 32**, Hassan discloses the system discussed above in claim 1, and further teaches that the remote receiving station is a standard bi-level facsimile machine and the image data signal is generated in a gray-scale format and protocol (column 3, lines 50 through 67, column 4, line 65 through column 5, line 9, and column 6, line 62 through column 7, line 2).

Regarding **claim 33**, Hassan discloses the system discussed above in claim 1, and further teaches that the remote receiving station is a gray-scale facsimile machine and the image data signal is generated in a gray-scale format and protocol (column 3, lines 50 through 67, column 4, line 65 through column 5, line 9, and column 6, line 62 through column 7, line 2).

Regarding **claim 34**, Hassan discloses the system discussed above in claim 1, and further teaches that the remote receiving station is a color facsimile machine and the image data signal is generated in a full color format and protocol (column 3, lines 50 through 67, column 4, line 65 through column 5, line 9, and column 6, line 62 through column 7, line 2).

Art Unit: 2622

Regarding *claim 35*, Hassan discloses the system discussed above in claim 1, and further teaches that the remote receiving station is a digital device and the image data is digital (column 2, line 45 through column 3, line 33, and column 4, line 65 through column 5, line 9).

Regarding *claim 36*, Hassan discloses the system discussed above in claim 1, and further teaches of a self-contained power source for powering the system (column 5, lines 23 through 25).

9. **Claims 1-3** are rejected under 35 U.S.C. 102(e) as being anticipated by Wertsberger (U.S. Patent Number 6,072,600, cited in the Information Disclosure Statement dated 1/20/04).

Regarding *claim 1*, Wertsberger discloses a self-contained image processing system (see Figs. 1 and 2) for capturing a visual image and transmitting it to a remote receiving station (see abstract, column 2, line 50 through column 3, line 25), with the system comprising an image capture device (CCD image sensor 1, column 4, lines 5 through 47), a processor (CPU 16) for generating a data signal representing the image (column 4, lines 20 through 58), a communications device (fax modem circuitry 13) adapted for transmitting the data signal to the remote receiving station (column 4, lines 48 through 67), and a wireless transmission system (telephone interface circuitry 15) between the communications device and the compatible receiving station (column 5, lines 1 through 6).

Regarding *claim 2*, Wertsberger discloses the system discussed above in claim 1, and further teaches of a memory for receiving and storing the data signal (memory means 11, and secondary storage 20), and wherein the communications device is adapted for recalling the stored data signal from memory (column 4, lines 48 through 67, and column 5, lines 24 through 27).

Art Unit: 2622

Regarding **claim 3**, Wertsberger discloses the system discussed above in claim 2 (as understood by the examiner), and further teaches that the memory is a removable RAM and wherein the system is adapted for selectively charging and discharging the memory (column 5, lines 24 through 27).

10. **Claims 1, 21, and 36-42** are rejected under 35 U.S.C. 102(e) as being anticipated by Parulski *et al.* (U.S. Patent Number 5,666,159, cited in the Information Disclosure Statement dated 1/20/04).

Regarding **claim 1**, Parulski discloses a self-contained image processing system (see Figs. 1, 2, and 7-9) for capturing a visual image and transmitting it to a remote receiving station (see abstract), with the system comprising an image capture device (camera module 10, column 3, lines 6 through 40), a processor (pen-based computer 12) for generating a data signal representing the image (column 3, lines 27 through column 4, line 6), a communications device (RF transmitter module 14) adapted for transmitting the data signal to the remote receiving station (column 4, lines 4 through 25), and a wireless transmission system between the communications device and the compatible receiving station (column 4, lines 7 through 25).

Regarding **claim 21**, Parulski discloses the system discussed above in claim 1, and further teaches that the system is of modular construction (see Fig. 1), and the camera (camera module 10), the processor (pen-based computer 12), and the communications device (RF transmitter module 14) are each independent, functional units which may be coupled to one another for defining the assembled system (see Figs. 1-3).

Regarding *claim 36*, Parulski discloses the system discussed above in claim 1, and further teaches of a self-contained power source for powering the system (column 3, lines 41 through 60).

Regarding *claim 37*, Parulski discloses the system discussed above in claim 36, and further teaches that the communications device is adapted to be used independently of the image capture device and the processor, and wherein the power supply is adapted for isolating the power to the communications device from the power to the image capture device and processor (column 3, lines 41 through 56).

Regarding *claim 38*, Parulski discloses the system discussed above in claim 37, and further teaches of a power initiation device associated with the image capture device and the processor, wherein the power to the image capture device and the processor is off when the initiation device is not activated (column 3, lines 41 through 56).

Regarding *claim 39*, Parulski discloses the system discussed above in claim 38, and further teaches that the power initiation device is user controlled (column 3, lines 41 through 56).

Regarding *claim 40*, Parulski discloses the system discussed above in claim 38, and further teaches of a trigger device for activating the power initiation device (column 3, lines 41 through 56).

Regarding *claim 41*, Parulski discloses the system discussed above in claim 40, and further teaches that the trigger device is a timer (see Fig. 5, and column 3, lines 33 through 60, whereby the flash 24 is equivalent to a timer, as it waits a predetermined amount of time to charge before firing).

Regarding *claim 42*, Parulski discloses the system discussed above in *claim 40*, and further teaches that the trigger device is triggered by the presence of an image to be captured (column 3, lines 41 through 60).

***Claim Rejections - 35 USC § 103***

11. The following is a quotation of 35 U.S.C. 103(a) which forms the basis for all obviousness rejections set forth in this Office action:

(a) A patent may not be obtained though the invention is not identically disclosed or described as set forth in section 102 of this title, if the differences between the subject matter sought to be patented and the prior art are such that the subject matter as a whole would have been obvious at the time the invention was made to a person having ordinary skill in the art to which said subject matter pertains. Patentability shall not be negated by the manner in which the invention was made.

12. **Claims 13-18, and 29** are rejected under 35 U.S.C. 103(a) as being unpatentable over Hassan *et al.* (U.S. Patent Number 5,550,646, cited in the Information Disclosure Statement dated 1/20/04) in view of Ross (U.S. Patent Number 5,546,194, cited in the Information Disclosure Statement dated 1/20/04).

Regarding *claim 13*, Hassan discloses the system discussed above in *claim 1*, but fails to expressly disclose if the image capture device is an analog video camera for generating a video signal.

Ross discloses a self-contained image processing system (see Fig. 1) for capturing a visual image and transmitting it to a remote receiving station, with the system comprising an image capture device (video camera 10, column 3, lines 4 through 5), a processor (control system 22 in Fig. 1, or CPU 44 in Fig. 2) for generating a data signal representing the image (column 3, lines 20 through 29, and column 3, line 63 through column 4, line 20), a communications device (Group III fax transmitter 20 in Fig. 1, and fax modem 50 in Fig. 2) adapted for transmitting the

Art Unit: 2622

data signal to the remote receiving station (column 2, lines 15 through 29, wherein the remote receiving station is inherently included in the system), and a subprocessor (Group III formatter 18) for generating a Group-III facsimile compatible signal representing the data signal (column 3, lines 30 through 52). Continuing, Ross teaches that the image capture device is an analog video camera for generating a video signal (column 3, lines 4 through 9). Further Ross teaches that the processor comprises a sync detector (sync separator 24, column 3, lines 53 through 62) and a video address generator (address multiplexer 43, column 4, lines 6 through 11) for synchronizing the digital signal with the analog signal for defining the beginning and end of the signal to define a still frame (column 3, lines 20 through 62), a random access memory (RAM 38) for receiving and storing the converted, synchronized signal frame-by-frame (column 4, lines 3 through 22), a processor routine for converting the signals stored in the memory to a protocol adapted for transmission (column 4, lines 22 through 36) to a remote, compatible protocol receiving station (inherently included), and a communications device (FAX modem 50) for transmitting the signal in the proper protocol to the compatible receiving station (column 5, lines 7 through 16).

Hassan & Ross are combinable because they are from the same field of endeavor, that being systems that transmit images from a camera to a destination via facsimile transmission.

At the time of the invention, it would have been obvious to a person of ordinary skill in the art to include the analog video camera that transmits a video signal, which is taught by Ross, in the system of Hassan.

Art Unit: 2622

The suggestion/motivation for doing so would have been that Hassan's system would become usable in more formats, as recognized by Ross in column 1, thereby increasing the system's desirability.

Therefore, it would have been obvious to combine the teachings of Ross with the system of Hassan to obtain the invention as specified in claim 13.

Regarding *claim 14*, Hassan and Ross disclose the system discussed above in claim 13, and Hassan further teaches that the processor routine converts the signals to a Group-III facsimile protocol, the system further including a facsimile modem for accepting the signal and transmitting to the compatible receiving station (column 4, line 65 through column 5, line 9).

Regarding *claim 15*, Hassan and Ross disclose the system discussed above in claim 13, and Hassan further teaches of a hardwired transmission system associated with the modem and a switching device for selecting in the alternative either the hardwired or the wireless transmission system (column 3, lines 10 through 17, and column 4, line 65 through column 5, line 9).

Regarding *claim 16*, Hassan and Ross disclose the system discussed above in claim 13, and Hassan further teaches of a local facsimile receiving system associated with the modem for providing local hard copy of the stored image signals in the memory (column 4, line 65 through column 5, line 22, and column 6, lines 10 through 21).

Regarding *claim 17*, Hassan and Ross disclose the system discussed above in claim 16, and Hassan further teaches of a switching device for selectively activating and deactivating the local facsimile receiving system (column 6, lines 10 through 21).

Art Unit: 2622

Regarding *claim 18*, Hassan and Ross disclose the system discussed above in claim 13, and Hassan further teaches of an integral viewer for viewing the images stored in the memory (LCD display 215, column 4, lines 19 through 64).

Regarding *claim 29*, Hassan discloses the system discussed above in claim 2, but fails to expressly disclose if the image data signal is stored in a raw video format.

Ross discloses a self-contained image processing system (see Fig. 1) for capturing a visual image and transmitting it to a remote receiving station, with the system comprising an image capture device (video camera 10, column 3, lines 4 through 5), a processor (control system 22 in Fig. 1, or CPU 44 in Fig. 2) for generating a data signal representing the image (column 3, lines 20 through 29, and column 3, line 63 through column 4, line 20), a communications device (Group III fax transmitter 20 in Fig. 1, and fax modem 50 in Fig. 2) adapted for transmitting the data signal to the remote receiving station (column 2, lines 15 through 29, wherein the remote receiving station is inherently included in the system), and a subprocessor (Group III formatter 18) for generating a Group-III facsimile compatible signal representing the data signal (column 3, lines 30 through 52). Continuing, Ross teaches of a memory for receiving and storing the data signal (RAM 38, column 3, line 65 through column 4, line 11), and that the image data signal is stored in a raw video format (column 3, line 63 through column 4, line 51).

Hassan & Ross are combinable because they are from the same field of endeavor, that being systems that transmit images from a camera to a destination via facsimile transmission.

At the time of the invention, it would have been obvious to a person of ordinary skill in the art to include the analog video camera that transmits a video signal, which is taught by Ross, in the system of Hassan.



Art Unit: 2622

The suggestion/motivation for doing so would have been that Hassan's system would become usable in more formats, as recognized by Ross in column 1, thereby increasing the system's desirability.

Therefore, it would have been obvious to combine the teachings of Ross with the system of Hassan to obtain the invention as specified in claim 29.

13. **Claims 19 and 20** are rejected under 35 U.S.C. 103(a) as being unpatentable over Hassan *et al.* (U.S. Patent Number 5,550,646, cited in the Information Disclosure Statement dated 1/20/04) in view of Ross (U.S. Patent Number 5,546,194, cited in the Information Disclosure Statement dated 1/20/04), and further in view of Wertsberger (U.S. Patent Number 6,072,600, cited in the Information Disclosure Statement dated 1/20/04).

Regarding *claims 19 and 20*, Hassan and Ross disclose the system discussed above in claim 13, but fail to expressly disclose if the memory is a removable memory medium which may be selectively removed from the system, with the removable memory medium comprising a PCMCIA card memory.

Wertsberger discloses a self-contained image processing system (see Figs. 1 and 2) for capturing a visual image and transmitting it to a remote receiving station (see abstract, column 2, line 50 through column 3, line 25), with the system comprising an image capture device (CCD image sensor 1, column 4, lines 5 through 47), a processor (CPU 16) for generating a data signal representing the image (column 4, lines 20 through 58), a communications device (fax modem circuitry 13) adapted for transmitting the data signal to the remote receiving station (column 4, lines 48 through 67), and a wireless transmission system (telephone interface circuitry 15)

Art Unit: 2622

between the communications device and the compatible receiving station (column 5, lines 1 through 6). Continuing, Wertsberger teaches of a memory for receiving and storing the data signal (memory means 11, and secondary storage 20), and wherein the communications device is adapted for recalling the stored data signal from memory (column 4, lines 48 through 67, and column 5, lines 24 through 27). Further, Wertsberger teaches that the memory is a removable memory medium which may be selectively removed from the system (column 5, lines 24 through 27), with the removable memory medium comprises a PCMCIA card memory (column 5, lines 24 through 27).

Hassan, Ross & Wertsberger are combinable because they are each from the same field of endeavor, that being systems that transmit images from a camera to a destination via facsimile transmission.

At the time of the invention, it would have been obvious to a person of ordinary skill in the art to include the removable PCMCIA card memory, which is taught by Wertsberger, in the system of Hassan and Ross.

The suggestion/motivation for doing so would have been that the system of Hassan and Ross would become more user-friendly, since allowing a user to load data on a portable, removable memory would aid the user's options of data storage, as recognized in column 5 by Wertsberger.

Therefore, it would have been obvious to combine the teachings of Wertsberger with the system of Hassan and Ross to obtain the invention as specified in claims 19 and 20.

Art Unit: 2622

14. **Claim 22** is rejected under 35 U.S.C. 103(a) as being unpatentable over Hassan *et al.* (U.S. Patent Number 5,550,646, cited in the Information Disclosure Statement dated 1/20/04) in view of Shibata *et al.* (U.S. Patent Number 5,689,300, cited in the Information Disclosure Statement dated 1/20/04).

Regarding **claim 22**, Hassan discloses the system discussed above in claim 1, but fails to expressly disclose if an audio signal capture device adapted for capturing an audio signal in correlation with the captured video signal.

Shibata discloses a self-contained image processing system for capturing a visual image and transmitting it to a remote receiving station (see Figs. 1, 8A, and 8B, and abstract), which includes an audio signal capture device adapted for capturing an audio signal in correlation with a captured video signal (column 17, lines 12 through 51).

Hassan & Shibata are combinable because they are from the same field of endeavor, that being systems that transmit images from a camera to a destination via facsimile transmission.

At the time of the invention, it would have been obvious to a person of ordinary skill in the art to include the teachings of capturing an audio signal, recognized by Shibata, in the system of Hassan.

The suggestion/motivation for doing so would have been that Hassan's system would become more convenient for a user, as the user would be able to communicate audio information along with video information, as recognized by Shibata in column 17.

Therefore, it would have been obvious to combine the teachings of Shibata with the system of Hassan to obtain the invention as specified in claim 22.

Art Unit: 2622

15. **Claim 28** is rejected under 35 U.S.C. 103(a) as being unpatentable over Hassan *et al.* (U.S. Patent Number 5,550,646, cited in the Information Disclosure Statement dated 1/20/04) in view of Bradley *et al.* (U.S. Patent Number 5,995,041, cited in the Information Disclosure Statement dated 1/20/04).

Regarding **claim 28**, Hassan discloses the system discussed above in claim 24, but fails to expressly disclose if the input device comprises a global positioning system.

Bradley discloses a self-contained image processing system for capturing a visual image and transmitting it to a remote receiving station (column 2, line 42 through column 3, line 6, and column 7, line 43 through column 8, line 30), with the system comprising an image capture device (column 7, line 43 through column 8, line 24), a processor (500, column 8, line 64 through column 10, line 2), a communications device adapted for transmitting a data signal to the remote receiving station (column 2, line 57 through column 3, line 6), and a wireless transmission system between the communications device and the compatible receiving station (see Figs. 1-3). Further, Bradley teaches that an input device comprises a global positioning system (column 2, lines 42 through 61).

Hassan & Bradley are combinable because they are from the same field of endeavor, that being systems that transmit images from a camera to a destination via facsimile transmission.

At the time of the invention, it would have been obvious to a person of ordinary skill in the art to include Bradley's teachings of using a global positioning system in the system of Hassan.

The suggestion/motivation for doing so would have been that Hassan's system would become more user-friendly with the addition of Bradley's GPS teachings, since the user would

Art Unit: 2622

automatically know the coordinates of where he is located, as recognized by Bradley in column 2.

Therefore, it would have been obvious to combine the teachings of Bradley with the system of Hassan to obtain the invention as specified in claim 28.

***Conclusion***

16. Any inquiry concerning this communication or earlier communications from the examiner should be directed to Joe Pokrzywa whose telephone number is (703) 305-0146. The examiner can normally be reached on Monday-Friday, 7:30-4:00.

If attempts to reach the examiner by telephone are unsuccessful, the examiner's supervisor, Edward L. Coles can be reached on (703) 305-4712. The fax phone number for the organization where this application or proceeding is assigned is 703-872-9306.

Information regarding the status of an application may be obtained from the Patent Application Information Retrieval (PAIR) system. Status information for published applications may be obtained from either Private PAIR or Public PAIR. Status information for unpublished applications is available through Private PAIR only. For more information about the PAIR system, see <http://pair-direct.uspto.gov>. Should you have questions on access to the Private PAIR system, contact the Electronic Business Center (EBC) at 866-217-9197 (toll-free).

Joseph R. Pokrzywa  
Examiner  
Art Unit 2622

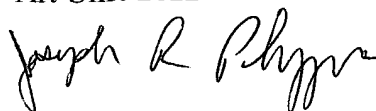

jrj

**APPARATUS FOR CAPTURING, CONVERTING AND TRANSMITTING  
A VISUAL IMAGE SIGNAL VIA A DIGITAL TRANSMISSION SYSTEM**

**Inventor: David A. Monroe**

**APPARATUS FOR CAPTURING, CONVERTING AND TRANSMITTING  
A VISUAL IMAGE SIGNAL VIA A DIGITAL TRANSMISSION SYSTEM**

[0001] This application is a divisional application of and claims priority from a non-provisional United States Application entitled Apparatus For Capturing, Converting And Transmitting A Visual Image Signal Via A Digital Transmission System, Serial No. 09/006,073, having a filing date of January 12, 1998; the specification and drawings of which are hereby incorporated by reference.

**BACKGROUND OF THE INVENTION**

**FIELD OF THE INVENTION**

[0002] The invention is generally related to image capture and transmission systems and is specifically directed to an image capture, compression and transmission system for use in connection with land line and wireless telephone systems.

**DISCUSSION OF THE PRIOR ART**

[0003] Industry has developed and continues to develop and enhance techniques for scanning, compressing, transmitting, receiving, decompressing, viewing and printing documents. This technology, encompassing the full body of facsimile transmission and reception, is currently in widespread use. The current standards, CCITT Group III and Group IV, define methods to scan and transmit high quality, bi-level images with a high degree of success and has become commercially acceptable throughout the world. However, gray scale documents are not easily transmitted because the scanners and algorithms are not tailored to the function. Three dimensional objects will not fit into the flat document scanners and cannot be transmitted.

[0004] Examples of systems that have addressed some of these issues are shown in U.S. Patent No. 5,193,012 which shows a video to facsimile signal converter, and U.S. Patent No. 3,251,937 which discloses a system for transmitting still television pictures over a telephone line.

[0005] Wire photography, and its extension, radio photography, have long been used by the news media. The most common form involves an input device that converts photographs into encoded signals for communication over telecommunications facilities or radio. At the receiving end, reproducing equipment reconverts the encoded image signals by exposing photographic film or other sensitized paper. The term facsimile is often used with these products.

[0006] Still video equipment has recently become available from vendors such as Kodak, Canon and Sony, and is again primarily used by television and print media, although applications are expanding rapidly in such areas as insurance investigations and real estate transactions. A still video camera captures a full color still video image that can be reproduced using a special video printer that converts the still video image data into hard copy form. For applications requiring communication of the still video image, transmit/receive units are available wherein the image begins and ends as a video image.

[0007] The Photophone from Image Data Corporation is an example of a specialty product that combines a video camera, display and storage facility in a terminal package. One terminal can send a real time or stored still video image to another for display or storage, or printing on special video printers. Again, the signal begins and ends as a video image.

[0008] Another example of a specialty product is peripheral equipment available for personal computers that enables the input/output, storage and processing of still video images in digitized formats. For instance, the Canon PV-540 is a floppy disk drive that uses conventional still video disks, digitizing and a still video image using a conventional format, and communicates with the computer through a standard communications I/O port.



[0009] U.S. Patent No. 5,193,012 discloses a still-video to facsimile conversion system for converting the still-video image frame into a half-tone facsimile reproduction without having to store an entire intermediated gray scale image frame by repeatedly transmitting the still-video image frame from a still-video source to an input circuit with a virtual facsimile page synchronization module. This system permits image to facsimile conversion by utilizing a half tone conversion technique.

[0010] While the various prior art systems and techniques provide limited solutions to the problem of transmitting visual images via a facsimile transmission system, all fall short of providing a reliable and convenient method and apparatus for readily capturing, storing, transmitting and printing visual images in a practical manner.

#### **SUMMARY OF THE INVENTION**

[0011] The subject invention is an image capture, compression and transmission system that is specifically designed to permit reliable visual image transmission over land line or wireless communications using commercially available facsimile transmission techniques. The invention incorporates a camera and signal converter into an integrated unit wherein the converted signal may be transmitted on a real time basis or may be stored in memory for later recall and transmission. The design of the invention permits maximum flexibility, with the camera/converter/telephone or other transmission device being designed in a modular configuration wherein any or all of the devices may exist as integrated or independent units.

[0012] The preferred embodiment permits capture of a video image using a digital camera, an analog camera, or a video camera such as a camcorder. The captured video image is then converted into still frame digitized format for transmission over any of a variety of transmission systems ranging from Group-III facsimile to computer, or to a like device at a remote location, in any protocol desired. The invention recognizes that once the signal is digitized, the transmission protocols are virtually endless.

[0013] For example, the present invention, permits a still frame visual image to be

captured at a remote location and sent immediately, over wireless communication systems, to a remote location such as, by way of example, a computer system wherein the image could be merged directly into newsprint. The image may also be sent to and printed as a hard copy using any Group-III facsimile machine, anywhere in the world. Where desired, the images may be stored in memory for later recall, and may be archived on a portable medium such as a memory card or the like.

**[0014]** The system of the subject invention is particularly useful for applications where immediate transmission of visual images of scenes, people and objects is desirable and sophisticated equipment is not always available for receiving the information. The system also provides a unique and reliable means for transmitting visual data to and from remote locations, such as, by way of example, law enforcement and emergency vehicles and the like.

**[0015]** In the preferred embodiment of the invention, the system includes a video camera and an integral cellular telephone, wherein the telephone using the standard audio mode or future digital modes, can be used to transmit and receive visual image signals. A desk model is also disclosed and permits connection to a standard land line telephonic system. A mobile console model is disclosed for use in law enforcement vehicles, and the like. Other communication systems are also supported by the subject invention, including hardwired networks, radio and satellite transmission and the like.

**[0016]** A local facsimile machine may be incorporated with the unit and can serve as a printer for providing hard copy of the captured image at the point of capture, as well as being adapted for receiving facsimile transmissions in the standard fashion.

**[0017]** The circuitry is disclosed for supporting any of the preferred configurations from a basic real time transmission system via Group-III fax to a comprehensive system supporting both land line and wireless transmission of image, audio and documentary data at both a local and remote station.

**[0018]** The subject invention also permits digitized collection of audio signals through

the use of an internal microphone, and external input device, a cellular telephone, land line telephone, wireless radio or other communication system, and digitized audio playback, as well. The playback can be via an internal speaker, out an external outjack to a remote device or via a cellular telephone, land line telephone, wireless radio or other communication system.

**[0019]** The digitized image and audio capture features permit association of audio with an image, as well as data with the image. Useful data associated with the image includes GPS from either internal or external GPS devices, range information from ranging devices, date and time, and text which may be input from an integrated keyboard or from a remote device.

**[0020]** It is an important feature of the invention that the system supports storage of images in an interim storage format including raw video, compressed video, interim gray scale format and/or half tone format. The image can also be stored in the selected output mode, such as by way of example, a Group III facsimile mode. The versatile capability of the system permits transmission of captured data to a standard bi-level facsimile machine such as Group III, to gray scale facsimile systems or full color facsimile systems, as well as to other remote receiving devices such as, by way of example, personal computers and network servers. The data may be transferred in any of a variety of formats and protocols including JPEG, FAX, wavelets, emerging imagery formats, FAX and computer data protocols. The invention is adapted to operate in multiple modes, with a unitary capture and send mode or separate capture and store, and send modes.

**[0021]** In the preferred embodiment, the system is adapted for tagging a collected image, video, audio, and other data such as a GPS information, with geospatial information and real time clock and added text. This permits the complete historical data to be transmitted simultaneously with the image signal.

**[0022]** It is contemplated that the system of the invention would be self-contained with an integral power unit such as a disposable battery, rechargeable battery source or the

like. Therefore, the system is adapted to power up when in use and power down or “sleep” when not activated, preserving power during idle time. The power systems for the video camera, the video input circuits and converters, the modem or other transmission devices and other high drain components may be isolated and only powered when needed. This also permits use of ancillary functions, such as use as a cellular telephone, to proceed without draining the power source by powering idle components. The processor clock rate may also be slowed down during idle mode to further conserve power.

[0023] Where desired, the system also includes camera operation control capability through the use of digital/analog circuits for converting digital commands to analog signals for controlling the gain, pedestal, setup, white clip, lens focus, white balance, lens iris, lens zoom and other functions of the camera from a local input device, a remote device or as automatic or programmed functions. The central processor may also be used to control camera shutter rate. Other camera features and parameters which may be controlled in this manner are compressor resolution ( such as high, medium, low user settings) corresponding to compression rate parameters, field/frame mode, color or monochrome, image spatial resolution (640x420 pixels, 320x240 pixels, for example), lens and camera adjustments, input selection where multiple cameras or video sources are used and the like.

[0024] When an integrated communications device is used, such as by way of example, a cellular telephone, the telephone can be isolated from the rest of the system to permit independent use, and independent power up and power off and other cellular phone functions.

[0025] In operation, the system permits not only the manual capture, dial (select) and send of images, but may also be fully automated to capture, dial and send, for example, on a timed sequence or in response to a sensor such as a motion sensor, video motion detection, or from a remote trigger device. The remote trigger also may be activated by an incoming telephone signal, for example.

[0026] The remote device may also be used for remote loading and downloading of firmware, and for setting of the programmable parameters such as to provide remote configuration of sampling modes during capture, compression rates, triggering methods and the like.

[0027] The triggering function permits a multitude of sampling schemes for a simple triggered activation for capturing an image upon initiation to a trigger signal to more complicated schemes for capturing and transmitting images prior to and after receipt of the trigger signal. The trigger function can be set to operate, for example, on a time per sample and number of sample basis, or time per sample and total sample time basis, or number of samples and total time basis. Depending on application, the trigger can sample in a prior to and after signal mode, using in combination the time per sample and number of samples prior and after signal basis, a total time basis, a percent prior versus percent after trigger basis, time per sample basis, time prior to and time after trigger basis, and other combination. For example, if the image capture device is positioned to monitor traffic accidents at a specific location, and an audio signal sensor identifying a crash were used as the trigger, it would be desirable to collect image sample both prior to and after the trigger signal. The number of samples, total sample time, and percentage of samples prior to and after trigger would be controlled by the specific application.

[0028] Circular sampling techniques are supported by the data capture system of the present invention. This is particularly useful when triggering events are used to initiate transmission of collected image data over the communications system. For example, if a triggering event is motion detected at a motion sensor, it may be useful to look at the images captured for a period of time both prior to and after the actual event. The circuitry of the subject invention permits any circular sampling technique to be utilized depending upon application, such as prior to an after trigger, only after trigger or only before trigger or prior to and after the trigger point. Again, as an example, it may be desirable to look primarily at images captured before a triggering event if the event is a catastrophic event such as an explosion or the like. Other circular sampling techniques may be employed, as well,

incorporating multiple cameras, for example, wherein different fields are sampled depending upon the time frame in a sequence of events.

[0029] It is, therefore, an object and feature of the invention to provide an apparatus for capturing, converting and transmitting a visual image via standard facsimile transmissions systems.

[0030] It is another object and feature of the invention to provide an apparatus for compressing the visual image data in order to minimize the capacity requirements of the data capture and storage system.

[0031] It is an additional object and feature of the invention to provide an apparatus for capturing and storing a visual image for later recall and review and/or transmission.

[0032] It is yet another object and feature of the invention to provide an apparatus for storing a captured video image in digital format on a portable storage medium.

[0033] It is an additional object and feature of the invention to provide an apparatus capable of sending and receiving telephonic audio messages, facsimile documents and captured visual images to and from standard, readily available remote stations.

[0034] It is a further object and feature of the invention to provide the means and method for capturing images prior to, prior to and after, or after a triggering event.

[0035] It is also an object and feature of the invention to provide for multiple triggering events and/or optional viewing or review of the captured images prior to printing or transmission.

[0036] It is another object and feature of the invention to provide an apparatus which may be activated from a remote location for initiating the capture of images by the device.

[0037] Other objects and features will be readily apparent from the drawings and detailed description.

### **BRIEF DESCRIPTION OF THE DRAWINGS**

[0038] Fig. 1. is a block diagram of a basic facsimile camera configuration for capturing an image via a camera and transmitting it via Group III facsimile transmission to a standard hard copy medium.

[0039] Fig. 2 is similar to Fig. 1, but incorporates a memory storage capability, permitting storage and optional review or viewing of the image prior to transmission.

[0040] Fig. 3 is similar to Figs. 1 and 2, but incorporates a data compression scheme for increasing the capacity of the memory and for increasing efficiency of transmission.

[0041] Fig. 4 includes the capture and transmission configuration of Fig. 2, with multiple transmission format capability including Group-III facsimile, personal computer, modem, parallel and serial transmission schemes.

[0042] Fig. 5 is an exemplary schematic diagram supporting the configurations shown in each of Figs. 1-4.

[0043] Figs. 6A, 6B, and 6C, are block diagrams of the physical components of desktop, portable and comprehensive console embodiments of the invention, respectively.

[0044] Fig. 7A and 7B are perspective drawings of a hand held device for capturing, storing and transmitting an image in accordance with the invention (new drawings to replace Frassinito design).

[0045] Figs. 8A-8L (Formerly Fig. 12) comprises a schematic diagram for an exemplary embodiment of the circuit for supporting the subject invention.

[0046] Fig. 9 is a diagram of the various triggering sequence options.

### **DETAILED DESCRIPTION OF THE PREFERRED EMBODIMENTS**

[0047] The image capture and transmission system of the subject invention is suited for capturing one or more single frame analog image or a digital image data signal and transmitting the captured signal via any of a plurality of transmission schemes to a remote receiving station where the image is downloaded in a suitable format for viewing and printing on hard paper copy, a CRT screen image, or other medium. The system is particularly well suited for sending and/or receiving images via a standard Group III facsimile transmission system and permits capture of the image at a remote location using an analog or digital camera. Two generic configurations are shown and described, the first, where each image is transmitted as it is captured, and the second, which permits capture, storage, and selective recall of captured images for transmission. The invention also contemplates a portable storage medium, wherein the captured stored medium may be removed from the capture device and archived for later use. While a system for black and white (gray tones) for Group-III facsimile transmission is described in detail herein, the invention could be readily adapted to transmission of color images utilizing the teachings of the present invention using industry standard color video standards and circuits. Both portable, or hand held, and stationary, or desktop, units are described. The circuitry utilized for both configurations is identical, but stationary configurations do not need a battery.

[0048] Figs. 1-5 are circuit configuration diagrams for the various capture, storage and transmission schemes. The physical embodiments utilized to employ the teachings of the schemes taught in Figs. 1-5 are not limited. Figs. 6-10 are exemplary physical embodiments of the subject invention.

[0049] Turning now to Fig. 1, the simplest embodiment of the invention incorporates a standard analog or digital camera device 10 for capturing a visual image in the typical



fashion. The camera 10 may be operator activated as indicated at 12, or may be programmed to be activated at selected intervals or in response to certain conditions. For example, a motion detector may be utilized to activate the camera 10 in a surveillance installation. Once activated, the camera 10 captures a visual image in typical fashion through a lens (see lens 192, for example, in Fig. 7A). In the illustrated embodiment, the captured image is then transmitted to a gray scale bit map memory device 16, from which it is output to a half-tone conversion scheme 18 to be input into a binary bit map 20 for formatting the captured image in a configuration suitable for transmission via a Group-III facsimile system. The signal generated at 22 by the binary bit map 20 is input into a Group-III encoding and compression network 24 for generating an output signal at 26 which is introduced into a Group III protocol transmission device 28. The output at 30 of the transmission device 28 is then transmitted into any standard transmission interface such as, by way of example, hard line telephonic transmission, cellular transmission, radio signal, satellite transmission or other transmission system 32 via a modem or similar device, as needed (as diagrammatically illustrated at 29), to be received via a compatible interface by a remote Group-III receiving system 34. The Group III receiving system 34 is a typical Group-III facsimile system comprising a Group-III receiver 36, decoder and decompressor 38 and binary bit map 40, from which a facsimile hard copy such as plain paper copy 42 may be generated.

[0050] This configuration is particularly well suited where real near time transmission is desired, for example when the system is operator controlled and a "real time" image is desired at a remote location. An example of such a system may be a photo identification confirmation of an apprehended suspect in law enforcement use, or transmission of images of damaged assets for insurance purposes, or transmission of images of construction job site conditions. This configuration is also well suited for use in those applications where a sensor activates the system and real time transmission of the sensed condition is desired. An example of such a system would be a motion activated camera in a surveillance location, where the image is immediately transmitted to a remote monitoring station. Of course, it will be readily understood by those who are skilled in the art that tagging a transmitted image with information such as, by way

of example, date, time and location, can be incorporated in the transmitted signal so that a receiving station could monitor a plurality of remote image data capture systems. This is also useful for reviewing a body of previously stored or printed images to determine the time and location of such image.

**[0051]** The embodiment of Fig. 2 is similar to Fig. 1, but incorporates a memory and optional operator viewer system. The image is captured by the camera 10 and conditioned by the gray scale bit map 16, as in Fig. 1. In this embodiment, the output 44 of the bit map 16 is input into a standard digital memory device 46 for later recall. This configuration is particularly well suited for applications where near real time transmission of the image either is not required or is not desirable. It will be noted that with the exception of the insertion of the memory device 46 and the optional viewer device 48, the capture and transmission system of Fig. 2 is identical to that shown and described in Fig. 1. Once the image is captured by the camera 10 and is presented at 44 to the memory device 46, it is stored for later recall and transmission. The specific type of memory device is optional and may include, for example, an SRAM device, a DRAM, Flash RAM, hard drive, floppy disk, PCMCIA format removable memory (see, for example, the PCMCIA card 50 in Fig. 7A), writeable optical media or other storage device. The memory may selectively capture images, as indicated by the operator interface/capture interface 52, or may be programmed to selectively capture periodic images or all images. In the embodiment shown in Fig. 2, an optional viewer device 48 is provided. This permits the operator to recall and view all or selective images before transmission, as indicated by the operator interface/recall interface 54. This permits the operator to review all images retained in the memory 46 and transmit selective images, as desired, to the Group-III transmission system. The remainder of the system of Fig. 2 operates in the same manner as the configuration shown and described in Fig. 1.

**[0052]** The configuration of Fig. 3 incorporates all of the features of Figs. 1 and 2, and additionally, includes an interim data compression and decompression scheme to permit increased utilization of the memory or storage medium 46. As shown in Fig. 3, an interim format compressor 56 is inserted between the gray scale bit map 16 and the memory device 46. This permits compression and reduction of the data required to

store the image, effectively increasing the capacity of the storage device. It is an objective of the storage device to preserve the gray scale quality of the image for viewing at the location of capture. An interim format decompression device 58 is inserted between the output of the memory device 46 and the rest of the system, whether the optional viewer 48 is utilized, or the output is entered directly into the half-tone convertor 18. The interim compression/decompression scheme is particularly useful when all of the image data is to be permanently archived, or when limited capacity portable media are used, such as, by way of example, floppy disks or a portable PCMCIA card. It will be noted that the remainder of the system shown in Fig. 3 is identical to the system shown and described in Fig. 2.

[0053] Fig. 4 illustrates the use of the image capture and/or retention configured in any of the optional embodiments of Figs. 1-3 and adapted for use in combination with any of a variety of transmitting and receiving schemes such as, by way of example, the Group-III system shown in Figs. 1-3, a modem, direct connection to a personal computer, serial or parallel transmission, or any selected transmitting/receiving protocol. This illustration demonstrates the versatility of the system once the image has been captured, converted and conditioned by the image capture device of the subject invention. Specifically, once the image is captured by the camera 10 and conditioned by the gray scale bit map 16, it may be stored and transmitted, or transmitted "real time" via any transmitting and receiving scheme. As shown in Fig. 4 the image capture device includes the memory device 46 and the optional viewer 48 for incorporating maximum capability. However, any of the schemes of Figs. 1-3 would be suitable for producing a transmittable signal. In the embodiment shown, a format select interface switch 60 is positioned to receive the fully conditioned signal on line 59. This would permit either automated or manual selection of the transmitting protocol, including the Group-III facsimile system previously described in connection with Figs. 1-3, as indicated by selecting format select switch 60 position A; or PC modem protocol as illustrated by the JPEG compressor 62 and protocol generator 64, as indicated by selecting format select switch position B; or the wavelet compressor and PC modem protocol, as illustrated by the wavelet compressor 66 and PC modem protocol generator 68 by selecting switch position C; or any selected conversion network 65, (if needed)

with a compatible compressor 67 (if needed) and compatible protocol generator 75 (if needed), as indicated by switch position D; or a serial protocol scheme 77, with serial drivers 79 directly to a hardwired personal computer 81 by selecting switch position E. Of course, it will be readily understood by those skilled in the art that one or a plurality of transmitting protocols may be simultaneously selected. Depending on the protocol selected, the signal output is generated at the selected output module and introduced to a communications interface module 83 via a modem or other device, as needed, for transmission via a transmission system to a compatible receiving station such as the Group-III facsimile device 34, the personal computer 85, the video telephone 89, and/or other server or receiving device 91 for distribution.

**[0054]** An exemplary circuit supporting the configurations of Figs. 1-4 is shown in Fig. 5. With specific reference to Fig. 5, an analog camera is indicated by the "video in" signal at 70. Typically, the video signal is a composite video/sync signal. The diagram shows all of the signal processing necessary to sync up to an NTSC signal 70 coming out of the analog camera and processed for introduction into an integral RAM memory 71 and/or a portable RAM memory via interface 73. An analog to digital (A/D) converter 74 converts the video portion of the analog signal from the camera and produces the digital signal for output at line 76. The digital output data on path 76 is introduced into a data multiplexer circuit 81 and into the RAM memory unit(s) 71, 72. In the exemplary embodiment, the portable RAM memory 72 is an image card such as, by way of example, a PCMCIA SRAM card or a PCMCIA Flash RAM card. However, it will be readily understood that any suitable RAM memory configuration can be used within the teachings of the invention. It is desirable to store compressed rather than raw data in card 72 because of space and transmission speed factors.

**[0055]** As the signal at 70 is introduced into the circuit, the sync detector 78 strips the sync signal portion off of the video signal. The sync signal drives the video address generator 80 for providing a signal used to generate an address signal at the address multiplexer circuit 82 for synchronizing the scanned in video signal with the locations in RAM to define each frame to be captured. The read/write control 84 controls the coordination of the sync signal 93 with the video signal to define a full frame.

Basically, when the camera is activated either by the operator or by automation, the system processor 86 detects the initiation of the camera and capture sequence and sends a signal via line 88 to the read/write control 84. The read/write control then monitors the incoming video signal 83 to find the horizontal and vertical sync pulse to identify the beginning of a frame. The read/write control then initiates writing to memory at the RAM devices to initiate capture of the frame. The read/write control continues to "write" to memory until the appropriate sync signal is received, indicating the end of the frame. At this point a single frame is captured in RAM 71 and/or on the portable medium RAM 72.

**[0056]** This frame may now be output from the system via any of the available transmitting schemes. In the exemplary embodiment, the processor 86 may be any processor or such as a microprocessor or DSP, with sufficient capability to perform the described functions. The processor bus is indicated at 87. The circuitry supporting the processor comprises the processor chip 86 and the control store memory (ROM, Flash RAM, PROM, EPROM or the like) 92 for storing the software program executed by the processor. It will be understood that other memory devices could be utilized without departing from the spirit of the invention. For example, a Flash RAM would permit flexibility and replacement of the program for upgrades and enhancements. The user interface commands are generated and interpreted by the software that is being executed by the processor 86.

**[0057]** The display unit 94 is connected through a typical interface 96, and provides visual user interface at the camera body to give the operator a visual read-out of the status of the collection and transmission of a selected frame. In the exemplary embodiment, the display unit is a two line, multi-character LCD display, but other sizes or technology displays could be readily incorporated, depending, for example, on the amount of graphics desired in the display module. The bank of operator buttons and/or switches 98 are connected to the system through the button interface 100.

**[0058]** The general purpose control register 102 serves as a latch and permits control bits to be introduced from the processor 86 to the transmitting systems or to transfer

status bits from the transmitting systems back to the processor in the well known manner. The modem 104 may be any of a variety of widely available modems or modem chip sets currently in commercial use. The modem should support CCITT Group III fax format for transmission to Group III fax machines. Once the signal is introduced into the modem 104, it is handled in typical fashion to provide input/output transmissions: (1) from the subject device to a hardwired telephonic line as indicated at 114, (2) from the subject device to the external facsimile machine as indicated at 116, or (3) from the subject device to an external wireless device telephone as indicated at 130. The specific selection is controlled by the user at button module 98 in conjunction with the processor 86.

[0059] An isolation transformer 110 is provided to isolate the circuitry connected to external communications circuit from the circuitry of the subject device. The relays at 108 and 112 permit patching directly into the hardwired telephonic line and to the telephone company system as indicated at 114, to an external handset or fax machine at 116, or to the modem 104, whereby facsimile data can be sent and received via the modem. These relays could be mechanical or solid state. The relay 118 is connected to a tone source 120 for providing an audible tone signaling to the user that the system is being used for transmitting or receiving a captured image.

[0060] With specific reference to the circuitry associated with relay 112, it will be noted that when the handset is switched away from the phone line to the tone source, the modem transformer 110 is switched to the telephone line 114. This blocks normal audio telephone service and permits the transmission of an image signal from the RAM devices 71 or 72, through the modem 104, and to the telephone line 114.

[0061] In the exemplary embodiment, a stand alone facsimile machine can be connected through the external handset jack at 116. With relay 112 set to activate telephone service and the tone generator 120 disconnected, the relay 108 can be set in either of two positions. The first position, as drawn, connects the facsimile machine at jack 116 to the telephone line, permitting standard facsimile transmission. The second or alternative position permits the modem 104 to transmit the image data signal

directly to the facsimile machine at jack 116, for providing an archive copy or the like. In this configuration, the facsimile machine will operate as a local printer for printing the captured images. Signal source 120 may be used as a ringing voltage generator for signaling such facsimile machine prior to connection.

**[0062]** The system of the present invention also contemplates wireless transmission over a cellular telephone, radio frequency, satellite transmission or the like. In the exemplary embodiment, the specific configuration for a cellular telephone interface is shown in detail. The amplifiers 122, 124 amplify the input of the modem 104 and are controlled by the FETs 126, 128, respectively. The FETs are controlled by the control register 102 and allow selection of the audio either coming in from the cellular interface 130 or from the telephone line 104 to the modem. This permits the cellular phone to be used for three distinct functions: (1) as an audio telephone, (2) as a transmitting system for transmitting the captured image and related signals via a cellular system, and (3) for receiving incoming transmissions to the processor. such as remote control, remote configuration, or images.

**[0063]** In the exemplary embodiment, the image card 72 is a DRAM card or non volatile storage card such as a Flash RAM or the like and provides a removable medium for storing the image data as either raw or compressed data. The card can also be used to store compressed data sent into the system via external facsimile transmission. As illustrated, the system is capable of both sending and receiving image data via Group-III fax or other protocol. By incorporating the digital to analog (D/A) converter into the system and pulling the signal from the RAM 71 (or portable RAM 72), the signal can be displayed right at the camera viewfinder 134 or other display device connected at port 138. A sync generator 136 is incorporated to provide synchronization of incoming data in the same manner. The sync detector 78 is utilized to define a frame-by-frame correlation of the data generated by the camera at the video input 70 for storage to memory 71 or 72.

**[0064]** Any standard power source may be utilized, including replaceable or rechargeable batteries 141, or an AC adapter 142. The AC adapter is particularly

suitable for desktop applications.

[0065] The exemplary embodiment includes a speaker or other audio transducer 144 for emitting a detectable signal whenever the user interface merits its use, such as user induced errors, system errors, user attention getting and the like.

[0066] In order to send a facsimile transmission over a typical Group-III Facsimile system, the multiplexer 82 is switched to the processor 86 such that the RAM address is generated by the processor 82 instead of the video address generator signal. In the facsimile transmitting mode, the processor accesses the RAM and manipulates the data representing each frame image. For example, the processor will perform the gray scale to half tone conversions described in connection with Figs. 1-4 to prepare the signal for facsimile transmission. The processor can also perform image compression and output the image as a gray scale. In the facsimile transmission mode, once the half tone conversion is completed, the processor executes a code for performing a bi-level compression of the data and the signal representing the frame data is output over line 90, through the multiplexer 81 and over the processor bus 87 to the processor 86, then to modem 104 for transmission. Other memory and processor configurations could be used without departing from the scope and spirit of the invention, as will be recognized by those skilled in the art.

[0067] Various physical configurations of the invention are shown in Figs. 7A & 7B. Figs. 6A, 6B and 6C are block diagrams for desktop and portable units. Figs. 7A and 7B illustrate the subject invention as incorporated in a standard 35 millimeter type camera housing.

[0068] A basic desktop system is shown in Fig. 6A, and includes a console unit having a telephone jack 152, an external telephone connection 154 and a video input/camera power jack 156 for connecting the analog camera 10. A facsimile machine may be also connected at jack 154 to provide local printer capability. The configuration shown in Fig. 6B is a basic portable system, with a battery powered portable module 160 having a self-contained power source 162. The system may include an integral RAM and/or



the removable memory module as indicated by the image card 72. The camera 10 may be an integral feature of the portable module 160, or may be a detached unit, as desired. In this embodiment, a cellular telephone 164 is provided with a data jack 166 for connecting to the output jack 168 of the module, whereby the image data signal may be transmitted via the cellular telephone to a remote facsimile machine over standard cellular and telephone company facilities. When incorporating the circuitry of Fig. 5, the cellular phone may be used as both an input and an output device, and incoming data or stored images may be viewed through the viewfinder 170.

[0069] Fig. 6C shows a comprehensive desk or stationary configuration incorporating all of the features supported by the circuitry of Fig. 5. As there shown, the control module 172 is adapted for receiving the image card 72 and is powered by an AC power adapter as indicated at 142. The camera 10 is connected to the module via a hardwired connection at jack 174. A monitor 176 is provided for viewing data images. A video cassette recorder 178 is provided and may be used as an auxiliary input device for the images transmitted from the system. The facsimile machine 180 can be used as a local printer, or can be used to send facsimiles transmissions in the well-known manner. Direct connections to the telephone line system are provided at jack 182. The FAX/phone jack 186 can be connected to a facsimile machine 180 and/or a standard telephone 184, where the public telephone system can be accessed. A data jack 188 is used to connect to a cellular telephone or the cellular modem, or other wireless device for transmission or reception of image data.

[0070] Turning now to Figs. 7A and 7B, the camera body 190 is similar to a standard 35 millimeter camera housing and is adapted to receive a standard lens 192 with a viewfinder 194. The electronics are housed in the casing in the area normally occupied by the film and film advancing implements. The operator interface button keys 98 are housed within the housing and may be positioned on the back plate 196 of the body. Fig. 8. The LCD unit may be positioned to be visible through the viewfinder 194 or may be in a separate back window 198. The memory card 72 is positioned in a slot 200 provided in a sidewall of the camera body. This camera has the appearance of a standard SLR 35 millimeter camera. In addition, where desired, an integral cellular

phone can be incorporated in the camera housing and transmission can be sent directly from the camera housing to a remote receiving station. The keypad for the telephone is indicated at 202.

[0071] Fig. 8 is an illustration of an exemplary schematic diagram for the circuit of a system according to the teaching of the invention as specifically taught in the diagram of Fig. 5. Pin numbers, wiring harnesses and components are as shown on the drawing. Fig. 8, part A, is the system interconnect and shows the central processor board 300, the video board 302, the power board 304 and the CRT electronic interconnect board 306. The telephone interface is provided at 307. Board 308 is the audio connector board. Board 310 is the serial connector board and board 312 is the video connector board. Fig. 8, part B contains the audio logic, with audio I/O at 314. The audio amplifiers are designated 316 and 318. A microphone connector is provided at 320, with preamplifier circuit 322. Audio switches are provided at 324 and 326. Summing circuit 328 provides audio summing. The serial RAM for audio is designated 330. Fig. 8, part C includes the camera module 332 and the camera control digital to analog convertor 334. Amplifier 336 is the video buffer. Module 338 is the camera shutter control resistor.

[0072] Fig. 8, part D contains the central processor unit 340. Voltage in is at 342, with the power switch at FET 344. Power shutdown is provided at the video shutdown bit 346. The video connector is designated at 348. Pin I is switched five volts out to video logic. Pins 2-9 are connected to the video data bus and pins 10-22 are video control signals. Buffers 350 and 352 are the video board I/O isolation buffers. As shown, pin 19 of buffer 352 is the output enable and is connected to the video shutdown bit 346. Line 354 is bus enable. Pin A0 of buffer 350 is the direction control signal and pins A1 A7 are connected to the processor data bus. Pins 10-17 of buffer 352 are also connected to the processor bus.

[0073] The system DRAM memory is designated 356. The processor I/O module is designated 358 and the I/O decoder is provided at 360. A non-volatile RAM 362 provides system parameters. The processor oscillator is shown at 364 and a real time clock at 366. Controller 368 is the RAM card controller. The PCMCIA socket for the

RAM card is shown at 370a and 370b. The modem is designated 372. The serial controller is shown at 374 with serial controller oscillator 376. Module 378 is a memory module. A signal buffer is provided at 380, and an address decoder at 382. Connectors are designated at 384, 386 and 388.

**[0074]** Fig. 8, part E shows the modem board connector at 390, the glue logic PLD at 392 and the glue logic module at 394. Module 396 is the synchronous/asynchronous serial controller. Circuit 398 is the signal multiplex relay and circuit 400 is the transmit/PTT relay. Bypass relays are shown at 402. Relay 404 is the digital mode relay. Transformer 406 is the audio isolation transformer. Circuit 408 provides a low speed data filter. The line drivers are designated 410 and the line rectifiers are designated 412, respectively. Connector 414 provides radio/serial data connection.

**[0075]** Fig. 8, part F shows the status LED's 416 and the PCMCIA door open switch 418. Fig. 8, part G shows the power switches 420. Fig. 8, part H is the battery pack 422.

**[0076]** Fig. 8, part I is the power supply. The rechargeable battery connection is shown at 424, with DC power input at 426. An internal battery/external DC input transfer relay is provided at 430. The signal for the power switch on the removable disk drive access door is on pins 3,4 of connector 428. The voltage IN regulator is designated at 432, with the processor voltage regulator designated 434. The processor power control bit is at 436. The system power control bit is at 438, with the system voltage regulator at 440. The video power control bits are at 442 and 444, with the video voltage regulators at 446 and 448, respectively. Battery 450 is the real time clock battery. Connector 452 is the battery charger connector. Connector 454 connects processor power, system power, regulated battery power and real time clock power, as shown. Connector 456 connects video power. The power sequencer circuit is at 458.

**[0077]** Fig. 8, part J shows the direct access arrangement to a land line telephone at 460 and the video viewfinder circuitry (CRT electronics) at 462.

[0078] Fig. 8, part K is the video control circuitry. The video input amplifier is designated at 464. The composite video sync stripper is designated at 466. The video H/V timing pulse generator is at 468 and the video phase lock loop at 470. The register 472 is the video control register. Circuit 474 provide programmable video filters--edge enhancers, with the FET switch designated at 476. The video filter circuit is at 478 and the video filter is at 480. The video reference digital to analog circuit-is shown at 482, with the video analog to digital circuit at 484 and the video analog to digital data out buffer at 486. The voltage reference circuit is designated at 488.

[0079] Fig. 8, part L shows the push button control switches as 490 and 492. The keyboard display is designated 494, and the microcontroller 496 is the keyboard and keyboard display microcontroller. The backlight circuitry is designated at 498, with the back light control at 500. Module 502 is the LCD module.

[0080] The circuitry supports any of the preferred configurations from a basic real time transmission system via Group-III fax to a comprehensive system supporting both land line and wireless transmission of image, audio and documentary data at both a local and remote station.

[0081] The subject invention also permits digitized collection of audio signals through the use of an internal microphone, and external input device, a cellular telephone, land line telephone, wireless radio or other communication system, and digitized audio playback, as well. The playback can be via an internal speaker, out an external out jack to a remote device or via a cellular telephone, land line telephone, wireless radio or other communication system.

[0082] The digitized image and audio capture features permit association of audio with an image, as well as data with the image. Useful data associated with the image includes GPS from either internal or external GPS devices, date and time, and text which may be input from an integrated keyboard or from a remote location.

[0083] It is an important feature of the invention that the system supports storage of

images in an interim storage format including raw video, interim gray scale format and/or half tone format. The image can also be stored in the selected output mode, such as by way of example, a Group III facsimile mode. The versatile capability of the system permits transmission of captured data to a standard bi-level facsimile machine such as Group III, to gray scale facsimile systems or full color facsimile systems, as well as to other remote receiving devices such as, by way of example, personal computers and network servers. The data may be transferred in any of a variety of formats and protocols including JPEG, FAX, emerging imagery formats, wavelets and data protocols. The invention is adapted to operate in multiple modes, with a unitary capture and send mode or separate capture and store, and send modes.

In the preferred embodiment, the system is adapted for tagging a collected image, video, audio, and other data such as a GPS signal, with a real time clock and added text. This permits the complete historical data to be transmitted simultaneously with the image signal.

**[0084]** It is contemplated that the system of the invention would be self-contained with an integral power unit such as a rechargeable battery source or the like. Therefore, the system is adapted to power up when in use and power down when not activated, preserving power during idle time. The power systems for the video camera, the video input circuits and converters, the modem or other transmission devices and other high drain components may be isolated and only powered when needed. This also permits use of ancillary functions, such as use as a cellular telephone, to proceed without draining the power source by powering idle components. The processor clock rate may also be slowed down during idle mode to further conserve power.

**[0085]** Where desired, the system also includes camera operation control capability through the use of a digital/analog network for converting digital commands to analog signals for controlling the gain, pedestal, setup, white clip, lens focus, and other functions of the camera from a local input device, a remote device or as programmed functions. The central processor may also be used to control camera shutter rate. Other camera features and parameters which may be controlled in this manner are compressor resolution (high, medium, low), field/frame mode, color or monochrome, image spatial

resolution (640x430, 320x240, for example), lens and camera adjustments, input selection where multiple cameras are used and the like.

[0086] When an integrated communications device is used, such as by way of example, a cellular telephone, the telephone can be isolated from the rest of the system to permit independent use, and independent power up and power off and other cellular phone functions.

[0087] In operation, the system permits not only the manual capture, dial (select) and send of images, but may also be fully automated to capture, dial and send, for example, on a timed sequence or in response to a sensor such as a motion sensor or from a remote trigger device. The remote trigger may be activated by an incoming telephone signal, for example. The remote device may also be use for remote loading and downloading of firmware, and of the programmable devices, as well as to provide remote configuration of sampling modes during both the capture and the send functions.

[0088] Circular sampling techniques are supported by the data capture system of the present invention. Fig. 9 is a diagram illustrating exemplary sampling techniques in accordance with the teachings of the invention. As shown in Fig. 9, the time sequence is indicated by the Time Line:  $t_1, t_2 \dots t_n$ , with a sample at each time interval, as indicated by  $S_1 \dots S_n$ . For purposes of illustration, the triggering event occurs at time interval  $t_{10}$ . Based on the predetermined programming of the system, images will start to be collected upon triggering event, as shown at 210, for a predetermined period prior to and after trigger, as shown at 212, or immediately preceding the trigger, as shown at 214. This permits "circular image storage" without requiring that all images be collected and stored in order to look at events surrounding a triggering event. The technique is also very useful when multiple overlapping zones are monitored by multiple devices and it is desirable to sequence from device to device without losing any critical images.

[0089] This is particularly useful when triggering events are used to initiate transmission of collected image data over the communications system. For example,

if a triggering event is motion detected at a motion sensor, it may be useful to look at the images captured for a period of time both prior to and after the actual event. The circuitry of the subject invention permits any circular sampling technique to be utilized depending upon application, such as prior to an after trigger, only after trigger or only before trigger. Again, as an example, it may desirable to look primarily at images captured before a triggering event if the event is a catastrophic event such as an explosion or the like. Other circular sampling techniques may be employed, as well, incorporating multiple cameras, for example, wherein different fields are sampled depending upon the time frame in a sequence of events.

[0090] Other configurations are contemplated and are within the teachings of the invention. While specific embodiments have been shown and described herein, it will be understood that the invention includes all modifications and enhancements within the scope and spirit of the claims.

**CLAIMS**

What is claimed is:

1. A self-contained image processing system for capturing a visual image and transmitting it to a remote receiving station, the image processing system comprising:
  - a. An image capture device;
  - b. A processor for generating a data signal representing the image;
  - c. A communications device adapted for transmitting the data signal to the remote receiving station;
  - d. A wireless transmission system between the communications device and the compatible receiving station.
2. The image processing system of claim 1, further including a memory for receiving and storing the data signal, and wherein the communications device is adapted for recalling the stored data signal from memory.
3. The image processing system of claim 1, wherein said memory is a removable random access medium and wherein the system is adapted for selectively charging and discharging the memory.
4. The image processing system of claim 1, wherein the image capture device is an analog camera for generating an analog image signal and there is further included an analog to digital converter for converting the analog image signal to a digital signal.
5. The image processing system of claim 1, further including a subprocessor for generating a Group-III facsimile compatible signal representing the digital signal.
6. The image processing system of claim 1, wherein the subprocessor comprises:
  - a. A gray scale bit map;
  - b. A half tone converter; and
  - c. A binary bit map.



7. The image processing system of claim 1, wherein there is further included an integrated wireless telephone associated with the communications device.
8. The image processing system of claim 1, further comprising a housing for housing all of the elements of the system in an integrated body.
9. The image processing system of claim 1, wherein said image capture device is a digital camera.
10. The image processing system of claim 2, further including a view screen for viewing the captured and stored image.
11. The image processing system of claim 5, further including a facsimile receiving device associated locally with the system for providing a local printer for reproducing the captured image in hard copy.
12. The image processing system of claim 1 wherein the processor is adapted for generating a signal in any of a plurality of selected protocols and wherein the communications device is adapted for transmitting the signal in the proper protocol to a remote, compatible receiving station.
13. The image processing system of claim 1, wherein:
  - a. The image capture device is an analog video camera for generating a video signal;
  - b. The processor further comprises:
    - i. An analog to digital converter;
    - ii. A sync detector and a video address generator for synchronizing the digital signal with the analog signal for defining the beginning and end of the signal to define a still frame;
    - iii. A random access memory for receiving and storing the converted, synchronized signal frame-by-frame;

- iv. A processor routine for converting the signals stored in the memory to a protocol adapted for transmission to a remote, compatible protocol receiving station;
  - c. A communications device for transmitting the signal in the proper protocol to the compatible receiving station.
- 14. The image processing system of claim 13, wherein the processor routine converts the signals to a Group III facsimile protocol, the system further including a facsimile modem for accepting the signal and transmitting to the compatible receiving station.
- 15. The image processing system of claim 13, further including a hardwired transmission system and a wireless transmission system associated with the modem and a switching device for selecting in the alternative either the hardwired or the wireless transmission system.
- 16. The image processing system of claim 13, further including a local facsimile receiving system associated with the modem for providing local hard copy of the stored image signals in the memory.
- 17. The image processing system of claim 16, further including a switching device for selectively activating and deactivating the local facsimile receiving system.
- 18. The image processing system of claim 13, further including an integral viewer for viewing the images stored in the memory.
- 19. The image processing system of claim 13, wherein the memory is a removable memory medium which may be selectively removed from the system.
- 20. The image processing system of claim 19, wherein the removable memory medium comprises a PCMCIA card memory.
- 21. The image processing system of claim 1, wherein the system is of modular construction, and the camera, the processor and the communications device are each independent, functional

units which may be coupled to one another for defining the assembled system.

22. The image processing system of claim 1, further comprising an audio signal capture device adapted for capturing an audio signal in correlation with the captured video signal.
23. The image processing system of claim 1, further comprising a data processor for creating a text data signal associated with said image data signal.
24. The image processing system of claim 23, further including an input device for providing text data to the data processor.
25. The image processing system of claim 24, wherein said input device is user controlled.
26. The image processing system of claim 25, wherein said user controlled input device is an integral keyboard.
27. The image processing system of claim 24, said input device comprising a real time clock.
28. The image processing system of claim 24, said input device comprising a global positioning system.
29. The image processing system of claim 2, wherein said image data signal is stored in a raw video format.
30. The image processing system of claim 2, wherein said image data signal is stored in a compressed format.
31. The image processing system of claim 2, wherein said image data signal is stored in a half-tone format.

32. The image processing system of claim 1, wherein the remote receiving station is a standard bi-level facsimile machine and the image data signal is generated in a standard bi-level facsimile machine format and protocol.
33. The image processing system of claim 1, wherein the remote receiving station is a gray-scale facsimile machine and the image data signal is generated in a gray-scale format and protocol.
34. The image processing system of claim 1, wherein the remote receiving station is a color facsimile machine and the image data signal is generated in a full color format and protocol.
35. The image processing system of claim 1, wherein the remote receiving station is a digital device and the image data is digital.
36. The image processing system of claim 1, further comprising a self-contained power source for powering the system.
37. The image processing system of claim 36, wherein said communications device is adapted to be used independently of the image capture device and the processor, and wherein the power supply is adapted for isolating the power to the communications device from the power to the image capture device and processor.
38. The image processing system of claim 37, further including a power initiation device associated with the image capture device and the processor wherein the power to the image capture device and the processor is off when the initiation device is not activated.
39. The image processing system of claim 38, wherein the power initiation device is user controlled.
40. The image processing system of claim 38, further including a trigger device for activating the power initiation device.
41. The image processing system of claim 40, wherein the trigger device is a timer.

42. The image processing system of claim 40, wherein the trigger device is triggered by the presence of an image to be captured.

**ABSTRACT**

[0091] An image capture, conversion, compression, storage and transmission system provides a data signal representing the image in a format and protocol capable of being transmitted over any of a plurality of readily available transmission systems and received by readily available, standard equipment receiving stations. In its most comprehensive form, the system is capable of sending and receiving audio, documentary and visual image data to and from standard remote stations readily available throughout the world.

Application of David A. Monroe  
Apparatus for Capturing, Converting  
and Transmitting Visual Image Signal  
Page 1 of 21

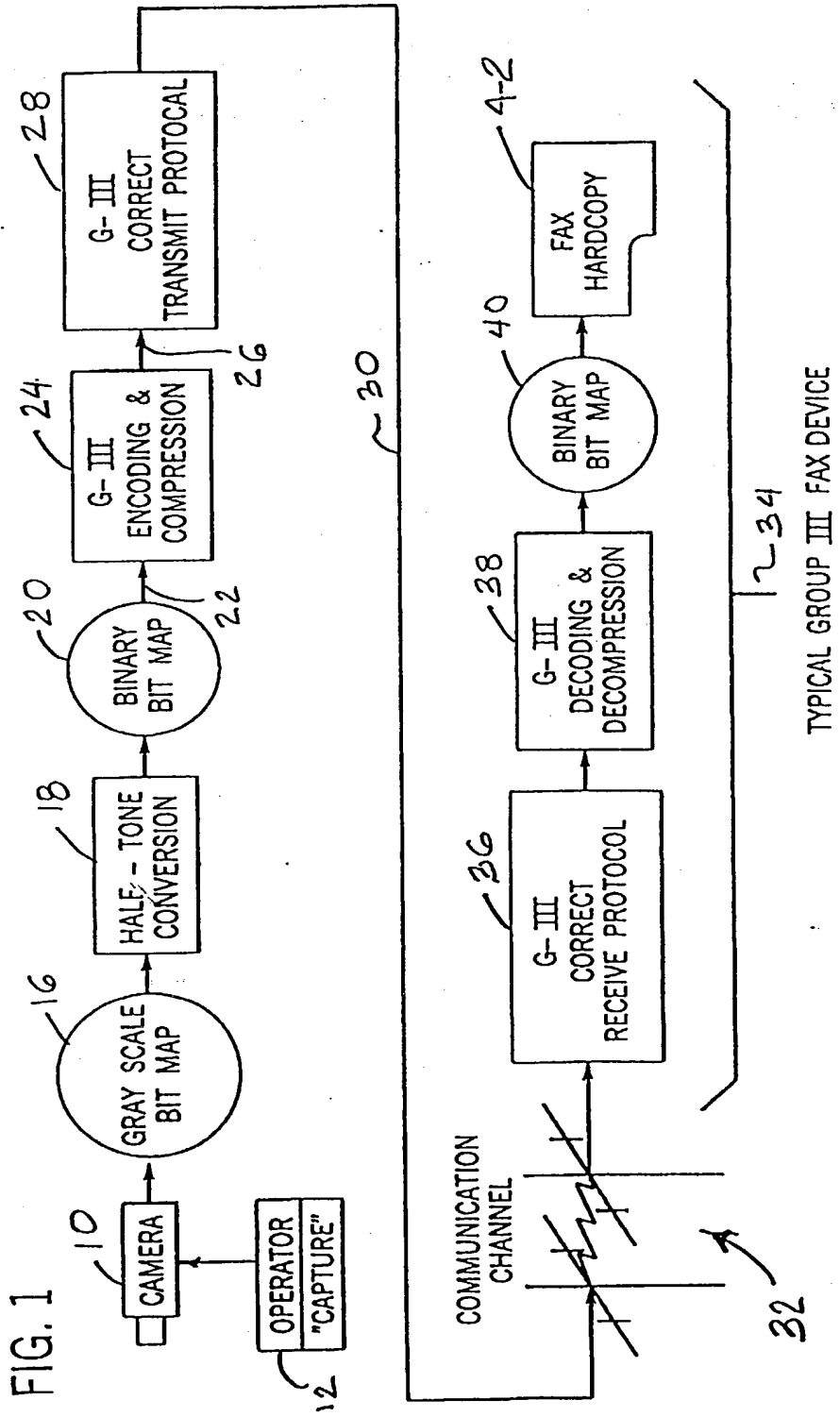
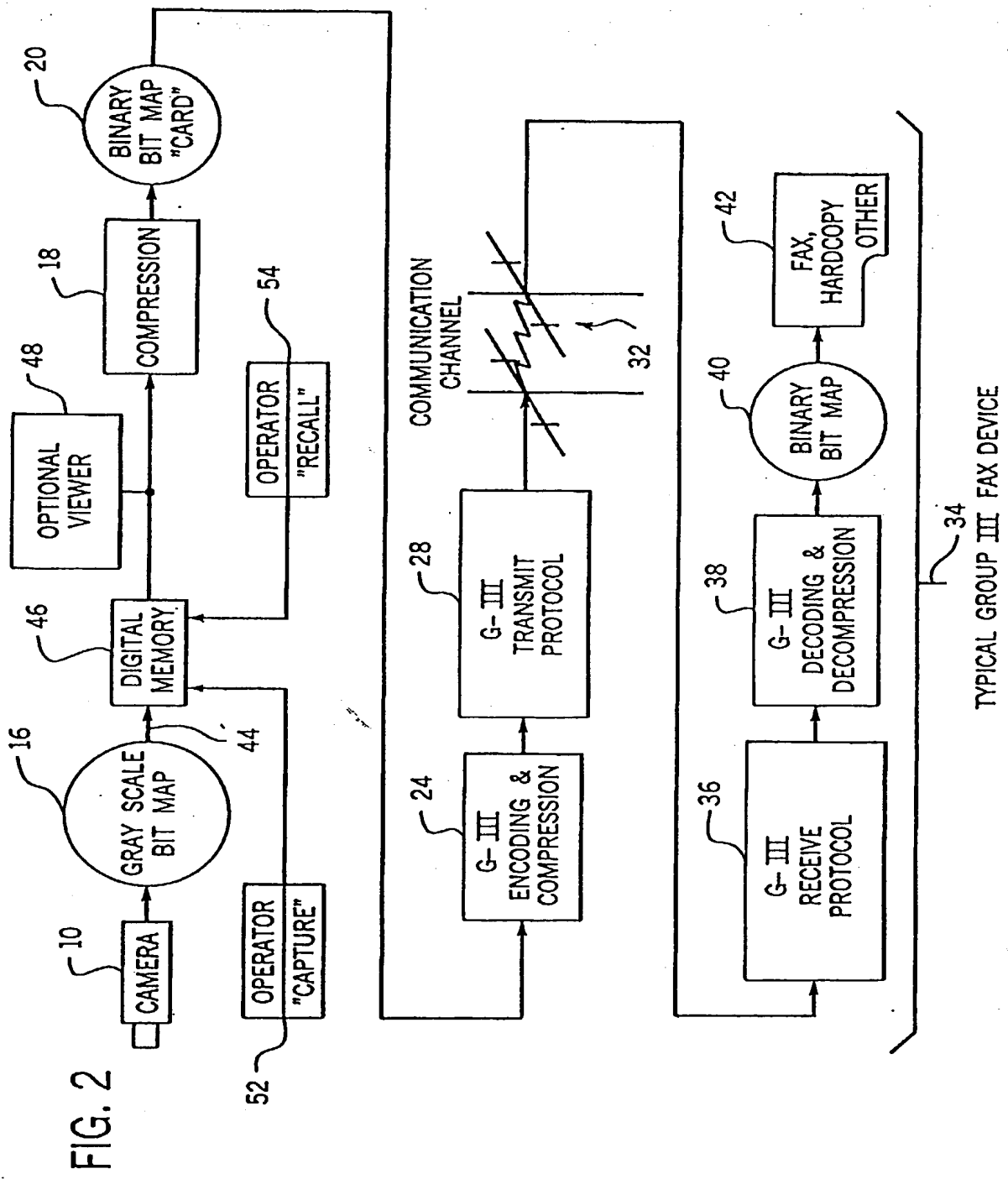

FIG. 1

Application of David A. Monroe  
Apparatus for Capturing, Converting,  
and Transmitting Visual Image Signal  
Page 2 of 21





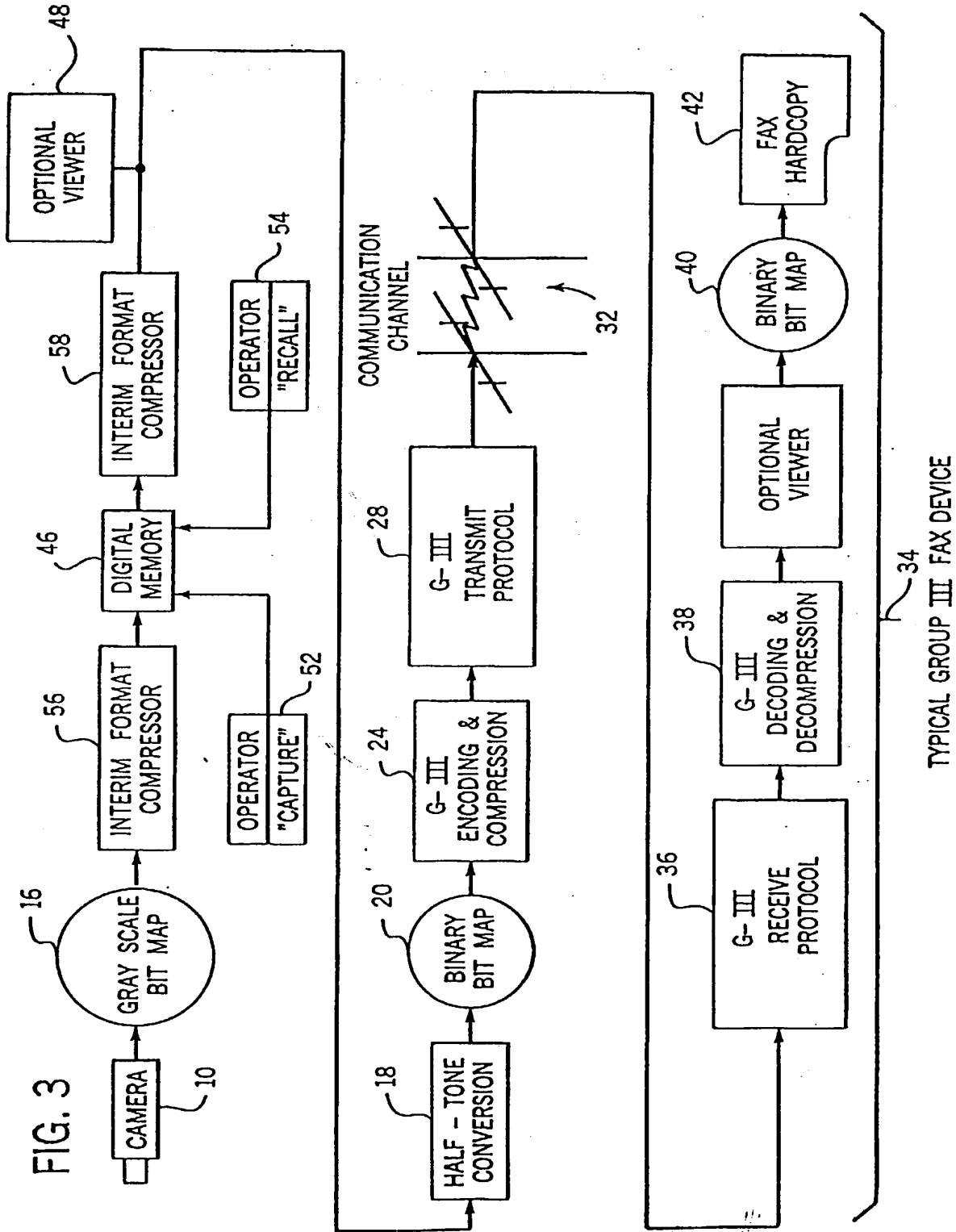
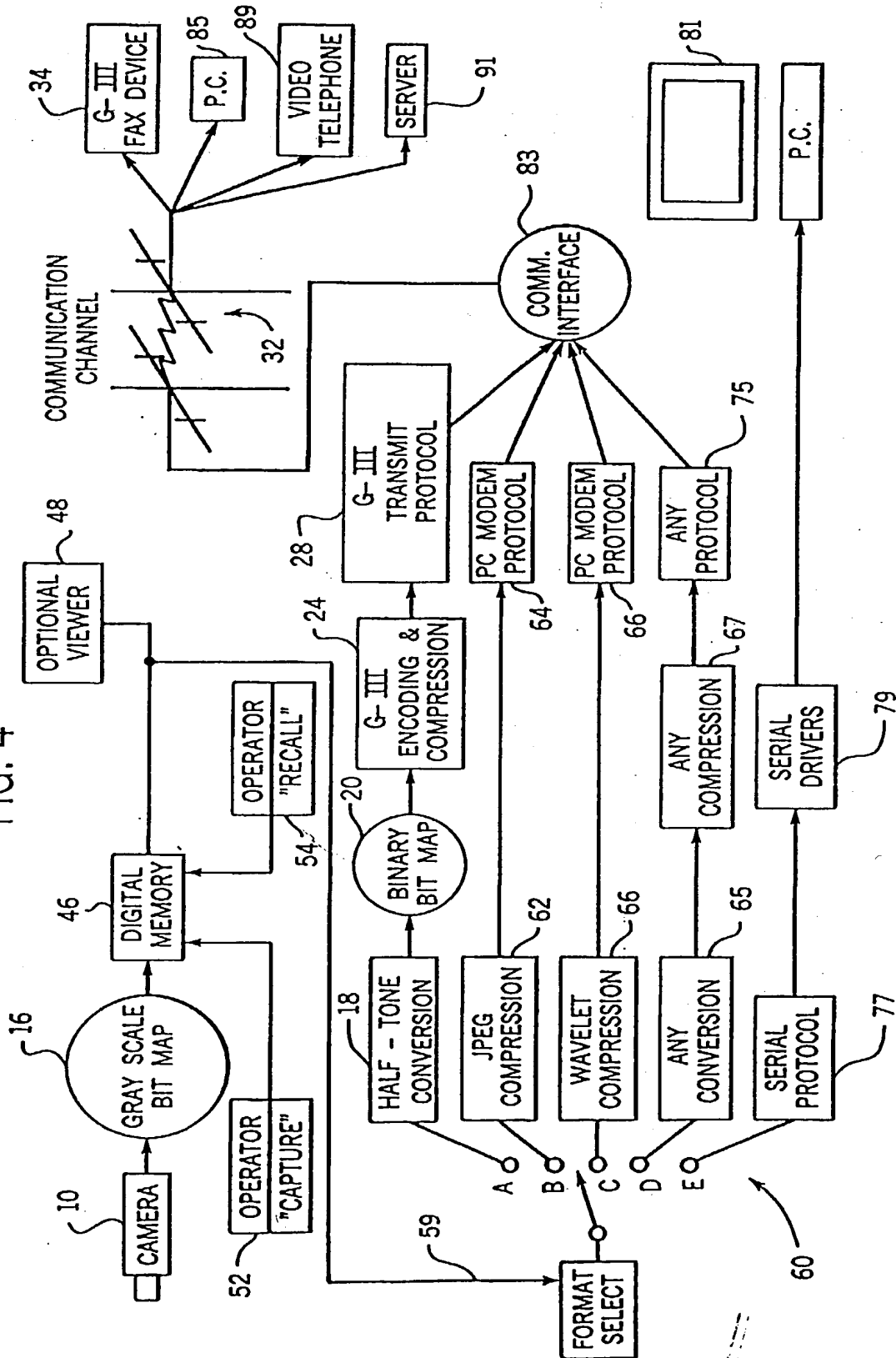

FIG. 3

FIG. 4



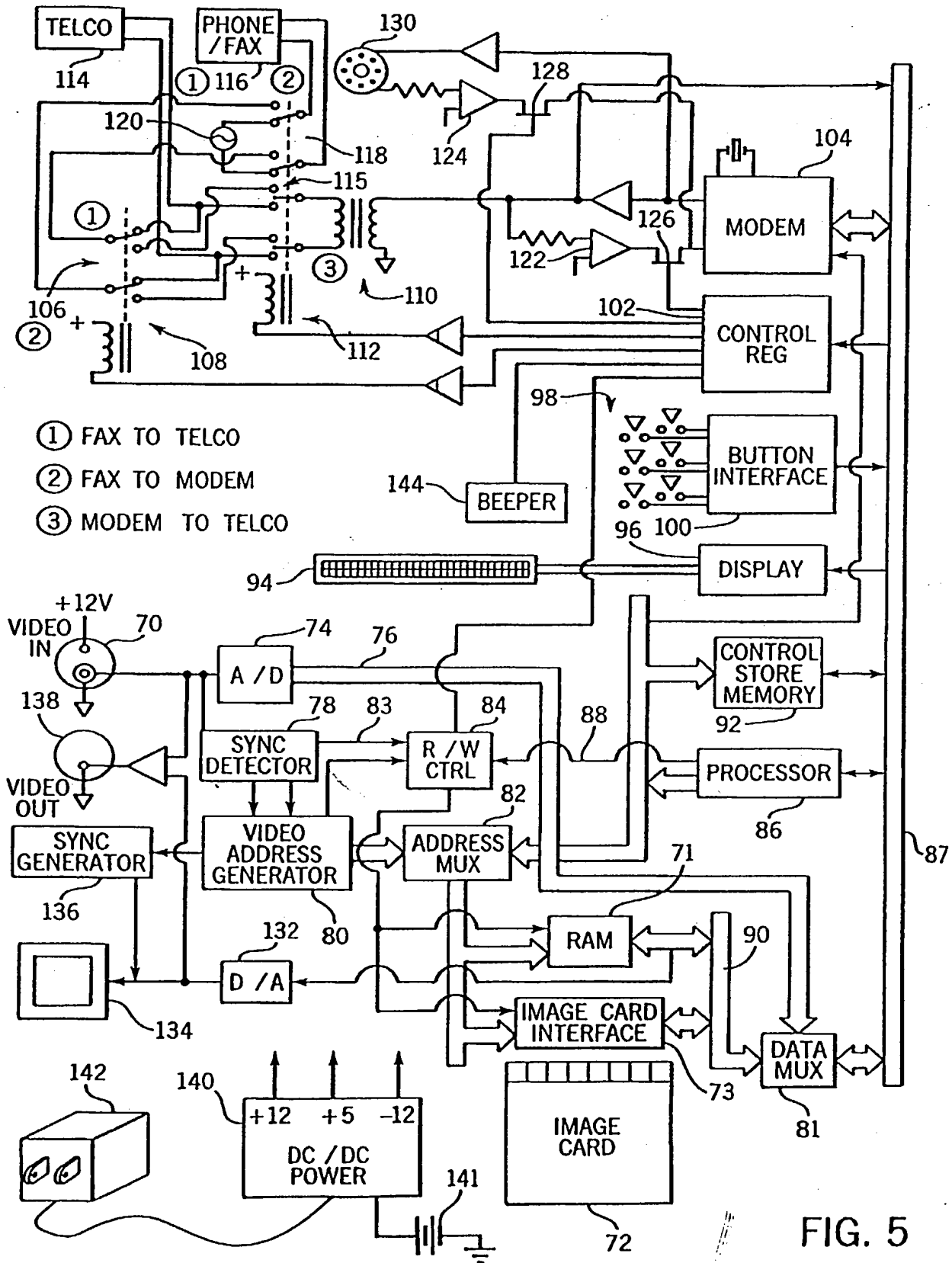

FIG. 5

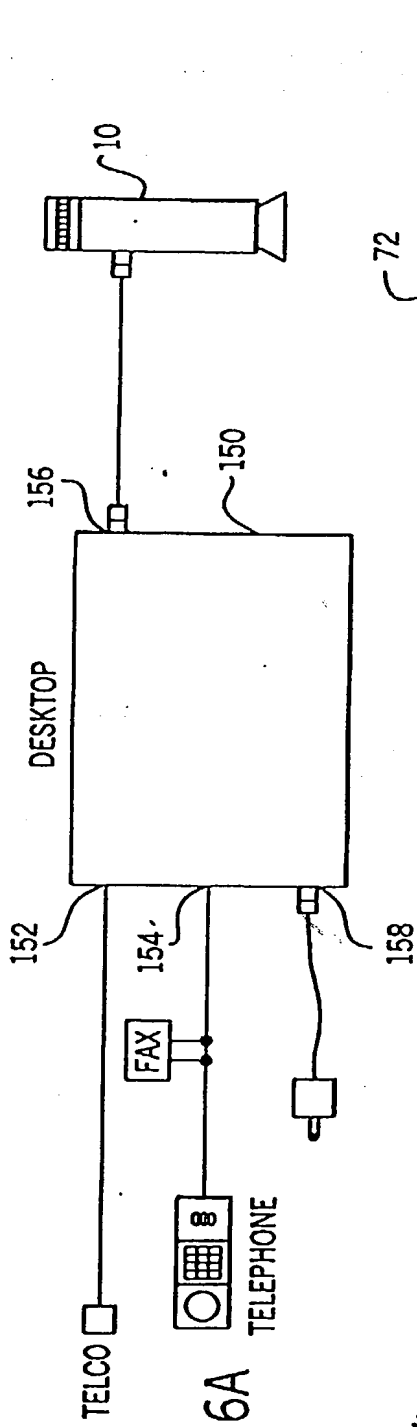

FIG. 6A

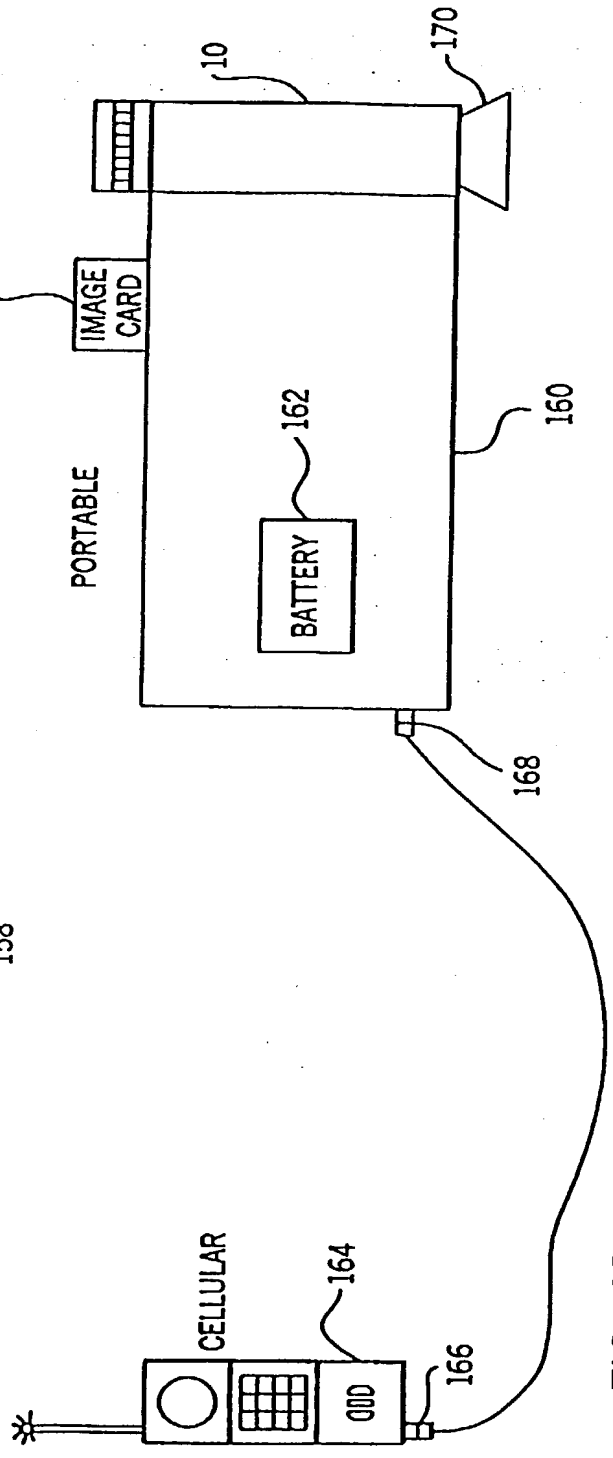

FIG. 6B

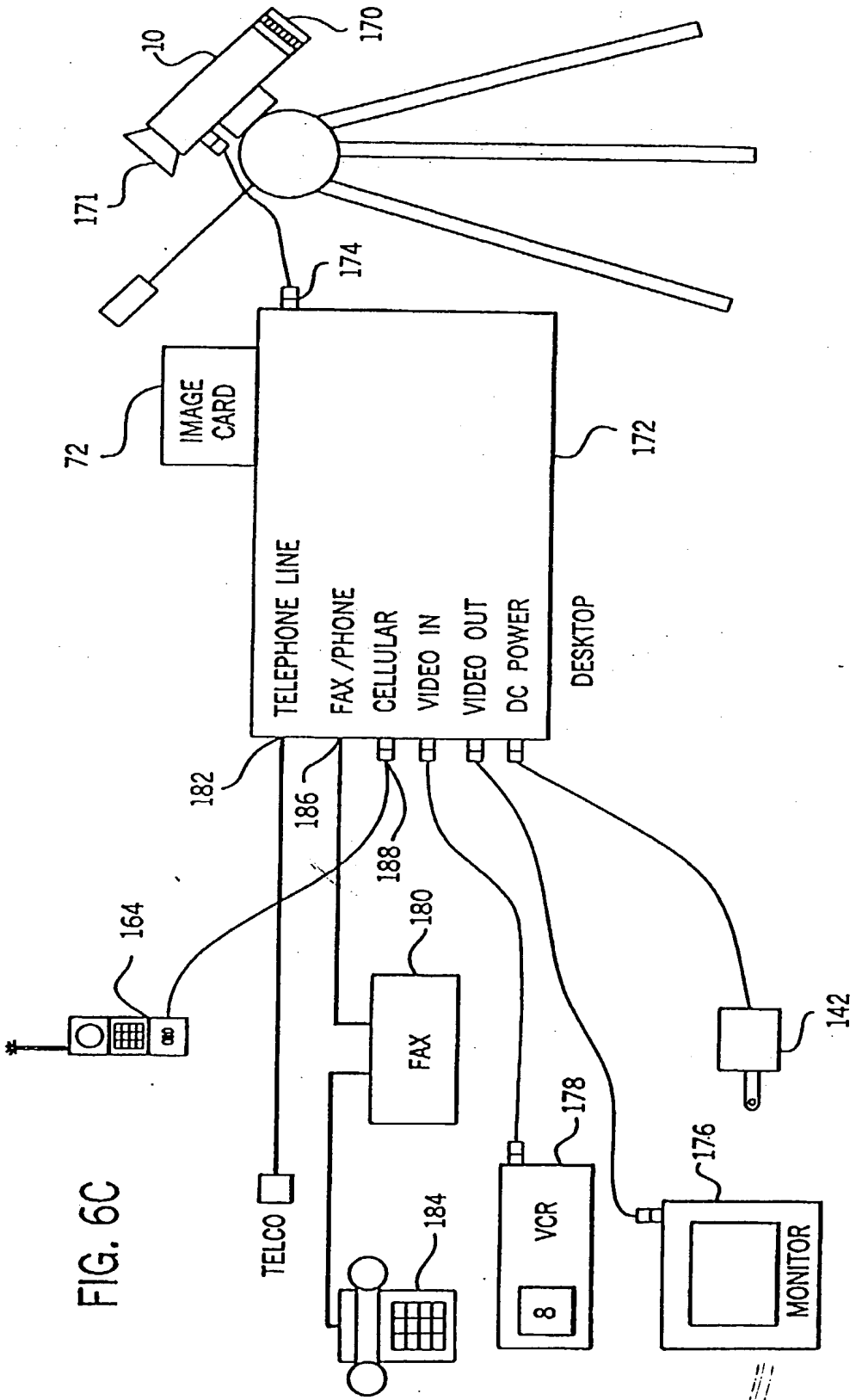

FIG. 6C

FIG. 7A

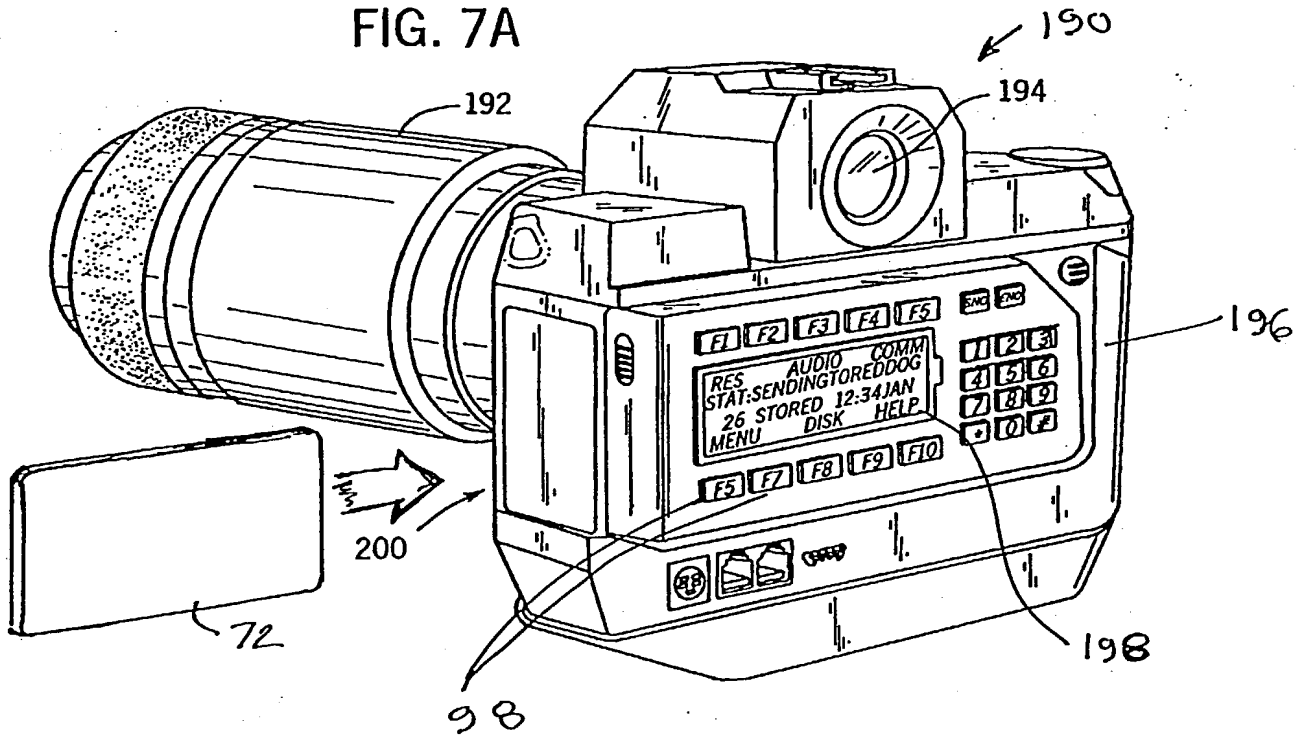

FIG. 7B

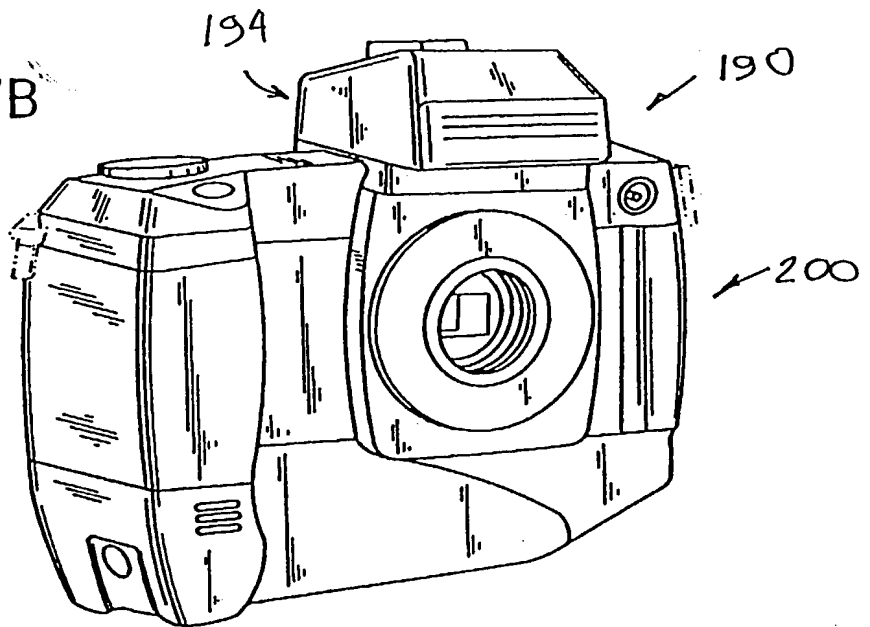

Fig. 8  
Part A

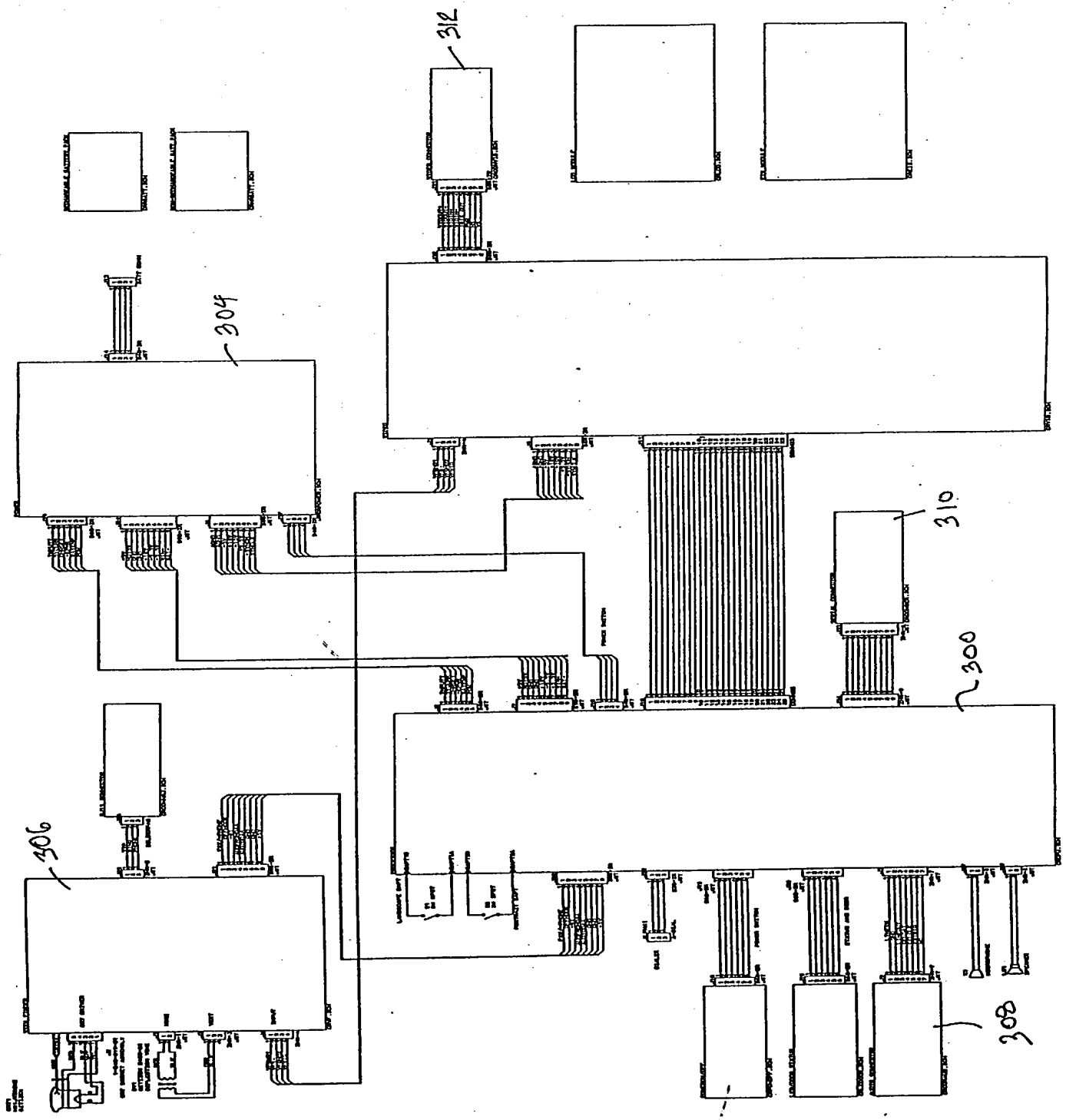
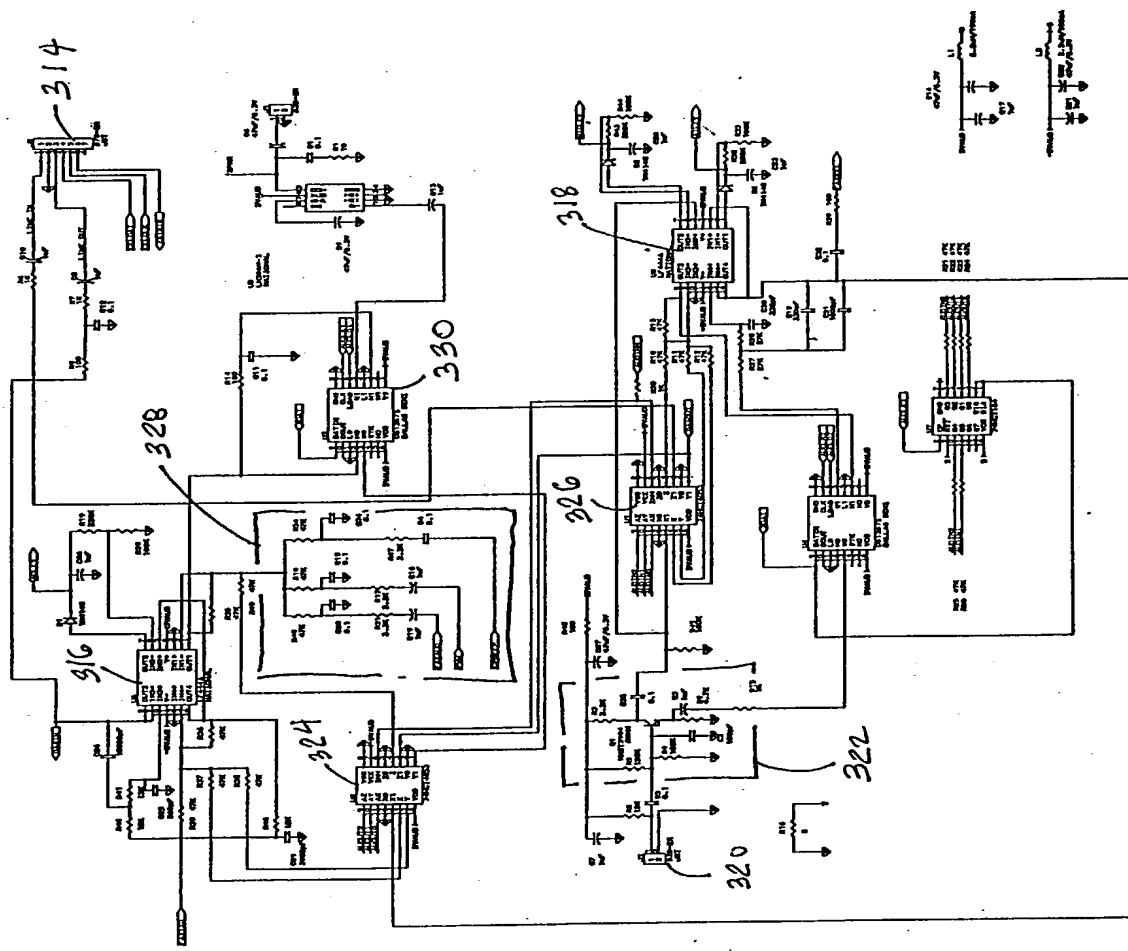

Fig 8  
Part B



Application of David A. Monroe  
 Apparatus for Capturing, Converting  
 and Transmitting Visual Image Signal  
 Page 10 of 21



Fig. 8  
Part C

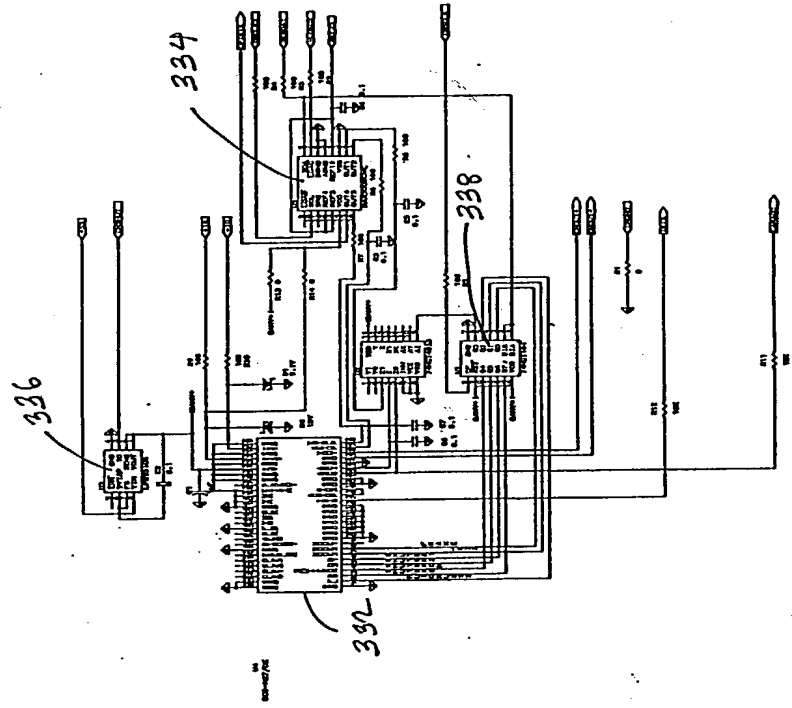

REPRODUCTION OF THIS DOCUMENT IS PROHIBITED BY LAW

Application of David A. Monroe  
Apparatus for Capturing, Converting  
and Transmitting Visual Image Signal  
Page 12 of 21

Fig. 9  
Part D

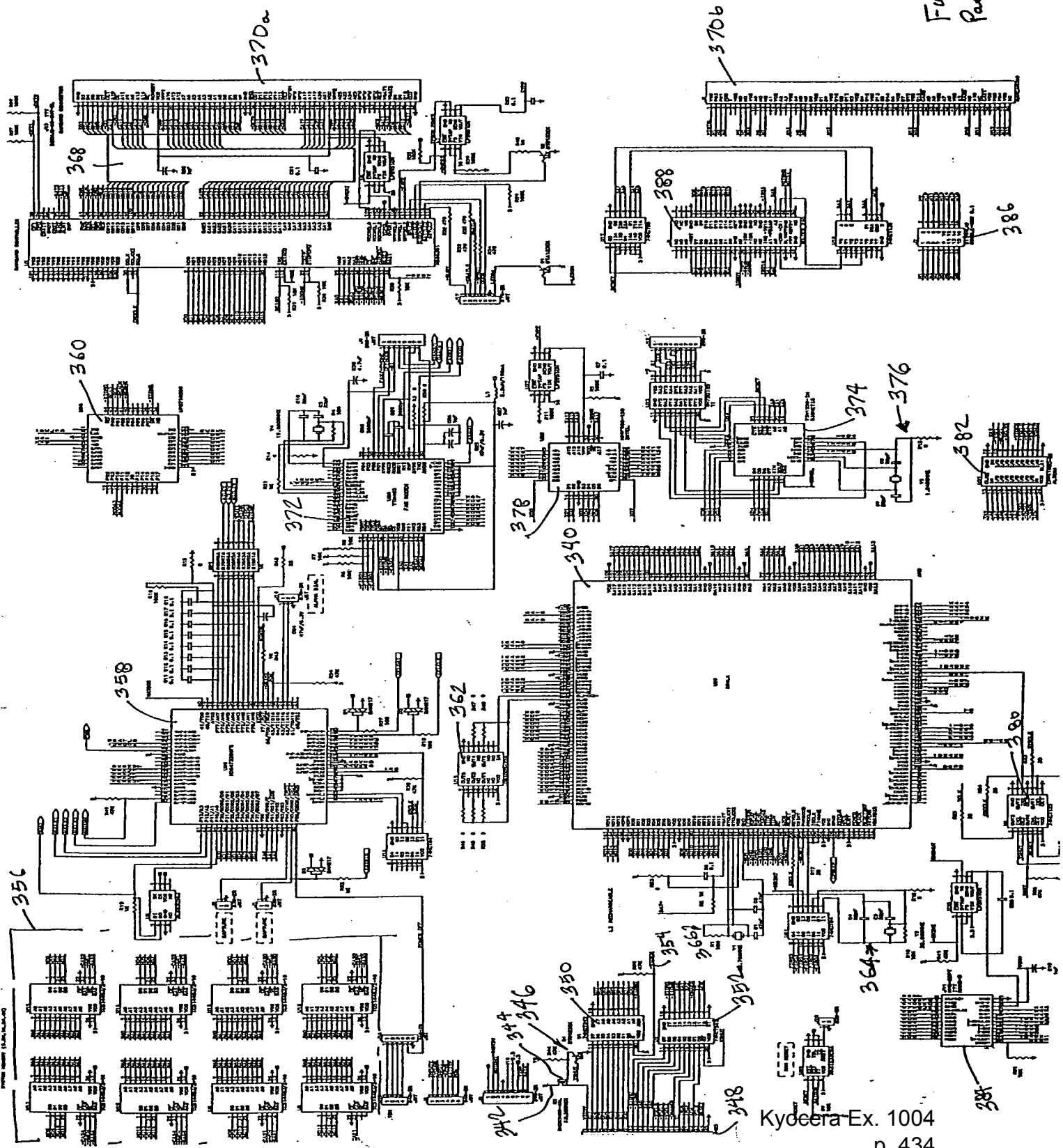

Application of David A. Monroe  
Apparatus for Capturing, Converting  
and Transmitting Visual Image Signal  
Page 13 of 21

Fig. 8  
Part E

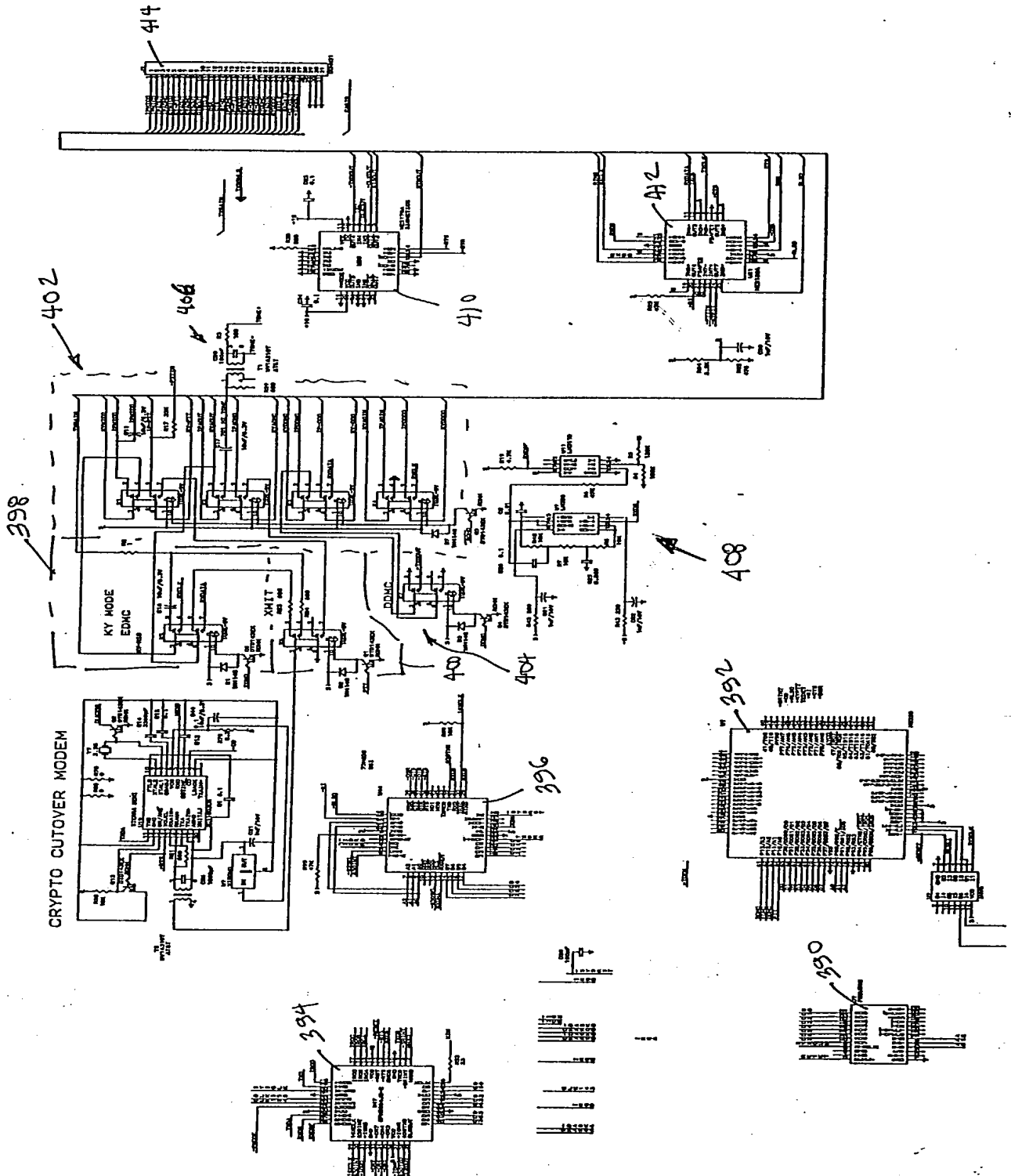
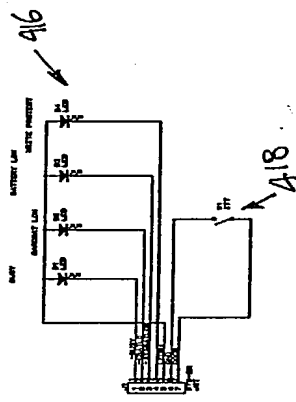

Fig 8  
Fig 4



8  
Print  
Part

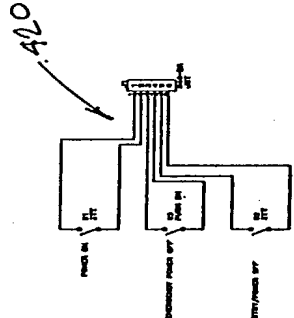

Fig. 8  
Rgt

Battery pack

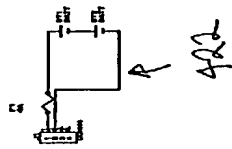

Fig. 8  
Part I

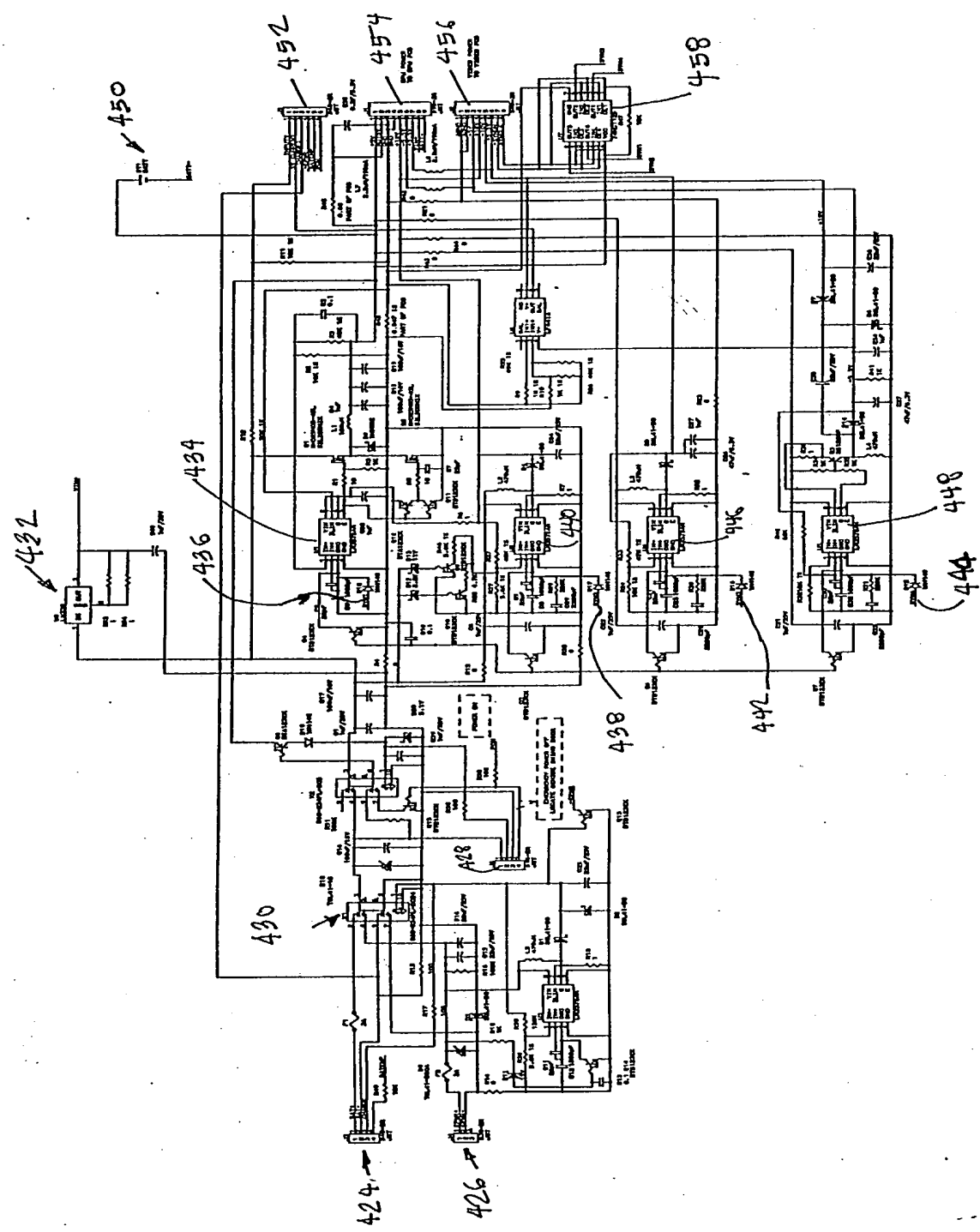

Fig. 6  
Part I

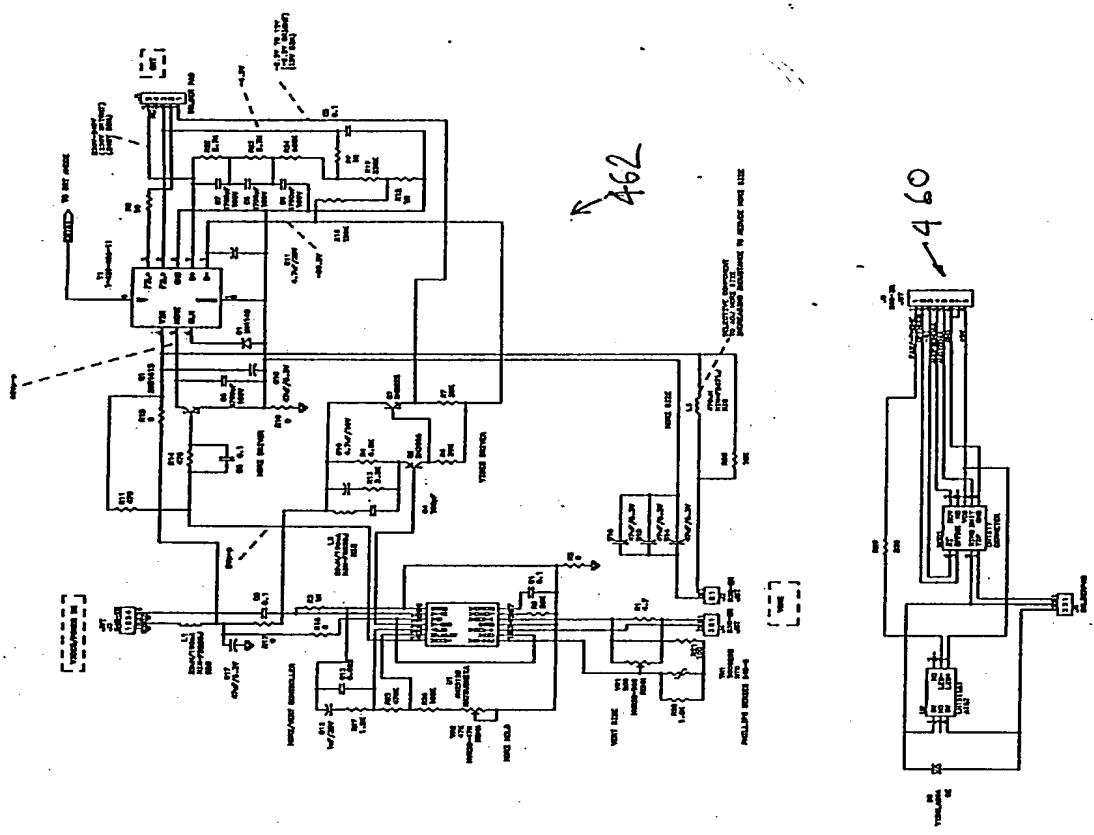
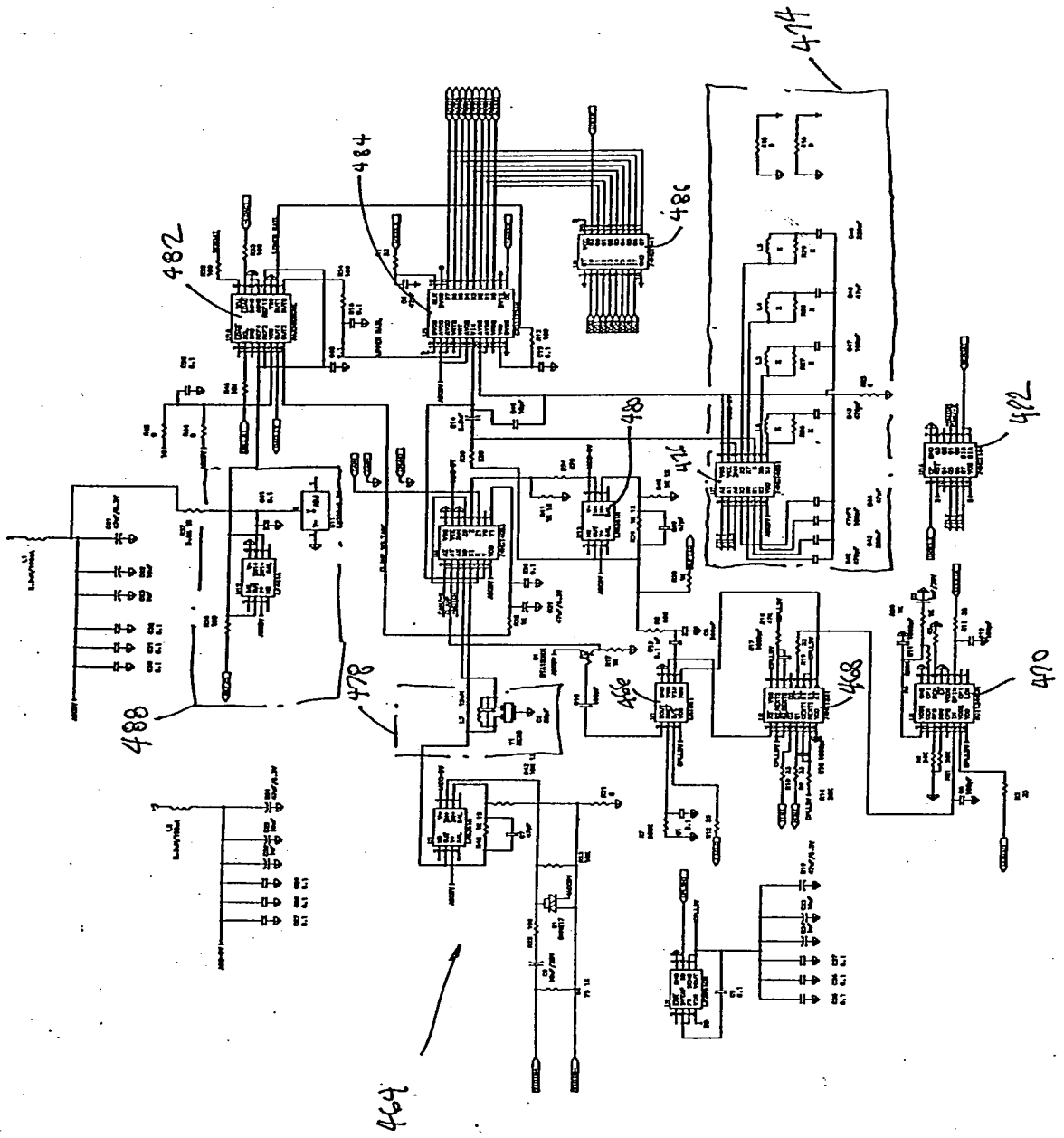

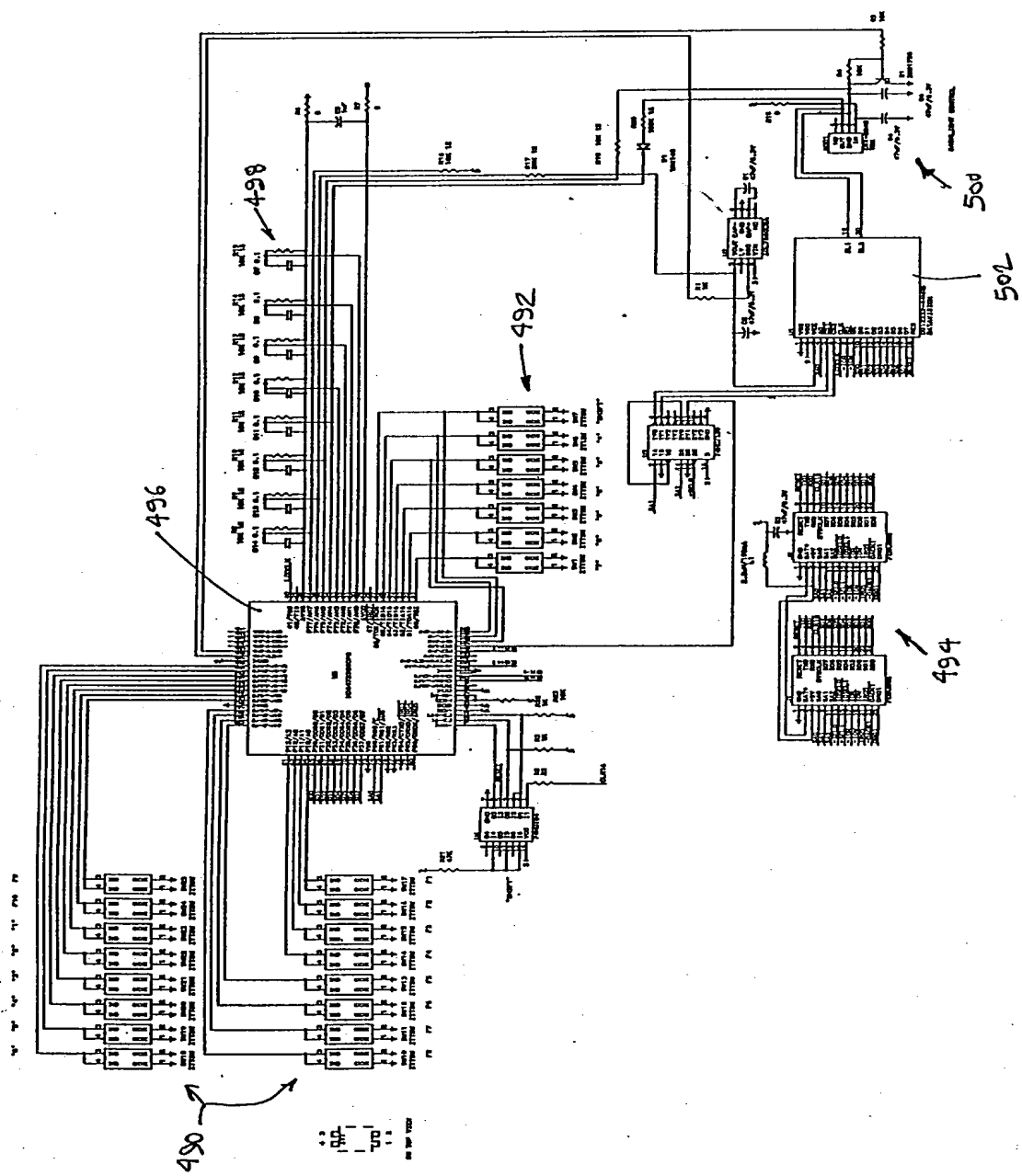

Fig. 8  
Part X



Application of David A. Monroe  
 Apparatus for Capturing, Converting,  
 and Transmitting Visual Image Signal  
 Page 19 of 21

Fig. 6  
Part L



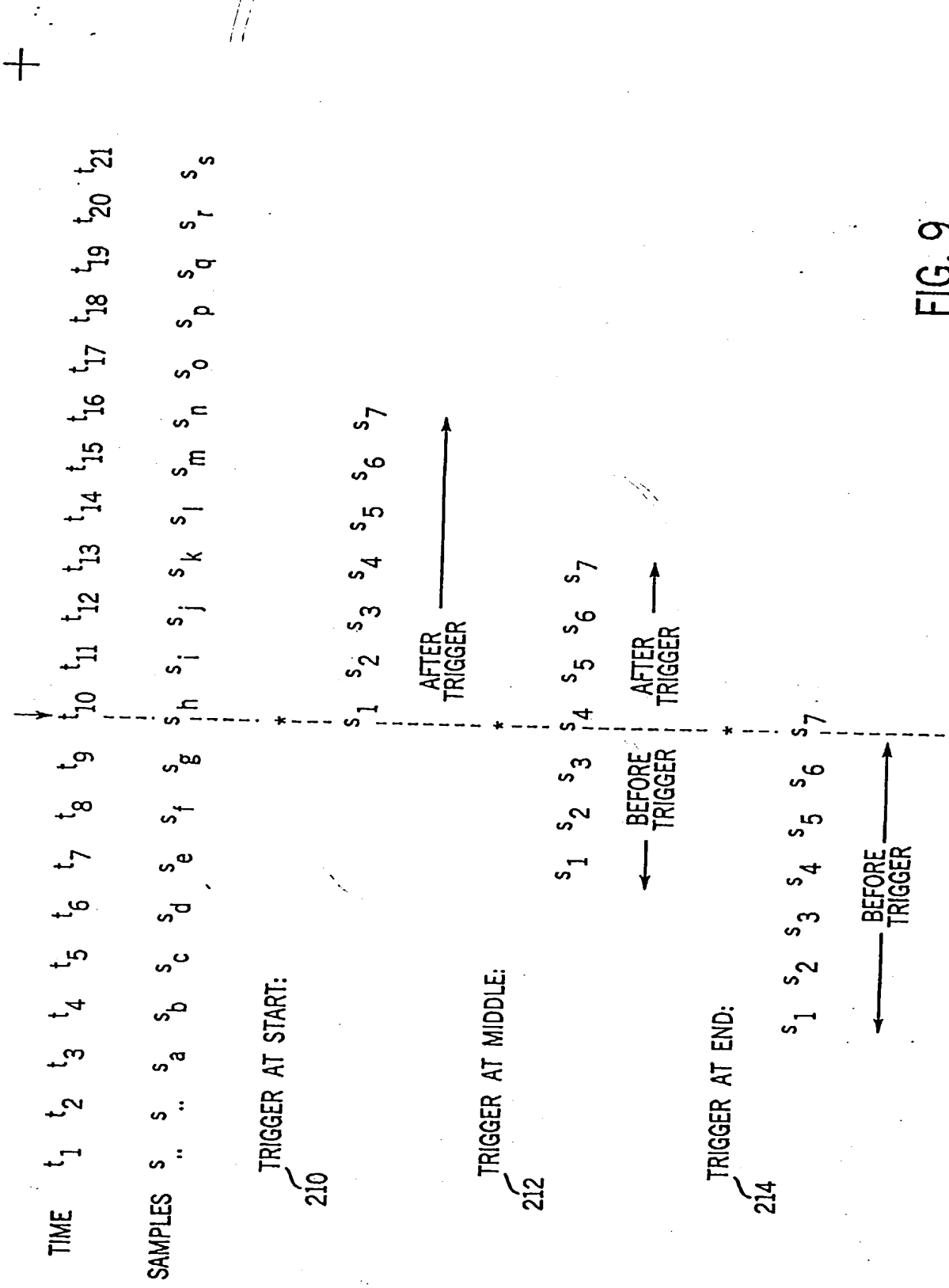

FIG. 9

10336470 010303