

- 8 -

and stores data concerning the wingspan 22 of the aircraft and other details concerning the size, shape and ICAO category (A to G) of the aircraft. The image processing system 8 classifies the aircraft on the basis of the size which can be used subsequently when determining the registration markings on the port wing 20. The data obtained can also be used for evaluation of the aircraft during landing and/or take-off.

Alternatively a pyroelectric sensor 27 can be used with a signal processing wing detection unit 29 to provide a tracking system 1 which also generates the acquisition signal using the trigger logic circuit 39, as shown in Figure 4 and described later.

Detecting moving aircraft in the field of view of the sensor 3 or 27 is based on forming a profile or signature of the aircraft, $P(y,t)$, that depends on a spatial coordinate y and time t . To eliminate features in the field of view that are secondary or slowly moving, a difference profile $\Delta P(y,t)$ is formed. The profile or signature can be differenced in time or in space because these differences are equivalent for moving objects. If the intensity of the light or thermal radiation from the object is not changing then the time derivative of the profile obtained from this radiation is zero. A time derivative of a moving field can be written as a convective derivative involving partial derivatives, which gives the equation

$$\frac{dP(y,t)}{dt} = \frac{\partial P(y,t)}{\partial t} + v \frac{\partial P(y,t)}{\partial y} = 0 \quad (3)$$

where v is the speed of the object as observed in the profile. After rearranging equation (3), gives

$$\frac{\partial P(y,t)}{\partial t} = -v \frac{\partial P(y,t)}{\partial y} \quad (4)$$

which shows that the difference in the profile in time is equivalent to the difference in the profile in space. This only holds for moving objects, when $v \neq 0$. Equation (4) also follows from the simple fact that if the profile has a given value $P(y_0, t_0)$ at the

- 9 -

coordinate (y_0, t_0) , then it will have this same value along the line

$$y = y_0 + v(t - t_0) \quad (5)$$

To detect and locate a moving feature that forms an extremum in the profile, such as an aircraft wing, the profile can be differenced in space $\Delta_y P(y, t)$. Then an extremum in the profile $P(y, t)$ will correspond to a point where the difference profile $\Delta_y P(y, t)$ crosses zero.

In one method for detecting a feature on the aircraft, a profile $P(y, t)$ is formed and a difference profile $\Delta_y P(y, t)$ is obtained by differencing in time, as described below. According to equation (4) this is equivalent to a profile of a moving object that is differenced in space. Therefore the position y_p of the zero crossing point of $\Delta_y P(y, t)$ at time t is also the position of the zero crossing point of $\Delta_y P(y, t)$ which locates an extremum in $P(y, t)$.

In another method for detecting a feature on the aircraft, the difference between the radiation received by a sensor 27 from two points in space is obtained as a function of time, $\Delta_y S(t)$, as described below. If there are no moving features in the field of view, then the difference is constant. If any object in the field of view is moving, then the position of a point on the object is related to time using equation (5). This allows a profile or signature differenced in space to be constructed

$$\Delta_y P(y(t), t) = \Delta_y S(t) \quad (6)$$

and, as described above, allows an extremum corresponding to an aircraft wing to be located in the profile from the zero crossing point in the differential signature.

The image acquisition system 10 includes at least one high resolution camera 7 to obtain images of the aircraft when triggered. The images are of sufficient resolution to enable automatic character recognition of the registration code on the port wing 20 or elsewhere. The illumination unit 16 is also triggered simultaneously to provide illumination of the aircraft during adverse lighting conditions, such as at night

- 10 -

or during inclement weather.

The acquired images are passed to the analysis system 12 which performs Optical Character Recognition (OCR) on the images to obtain the registration code.

5 The registration code corresponds to aircraft type and therefore the aircraft classification determined by the image processing system 8 can be used to assist to the recognition process, particularly when characters of the code are obscured in an acquired image. The registration code extracted and any other information concerning the aircraft can be then passed to other systems via a network connection 24.

10

Once signals received from the pyroelectric sensors 21 indicate the aircraft 28 is within the field of view of the sensors 3 of the tracking sensor system 6, the tracking system 1 is activated by the proximity detector 4. The proximity detector 4 is usually the first stage detection system to determine when the aircraft is in the proximity of the
15 more precise tracking system 1. The tracking system 1 includes the tracking sensor system 6 and the image processing system 8 and according to one embodiment the images from the detection cameras 3 of the sensor system 6 are used by the image processing system 8 to provide a trigger for the image acquisition system when some point in the image of the aircraft reaches a predetermined pixel position. One or more
20 detection cameras 3 are placed in appropriate locations near the airport runway such that the aircraft passes within the field of view of the cameras 3. A tracking camera 3 provides a sequence of images, $\{I_n\}$. The image processing system 8 subtracts a background image from each image I_n of the sequence. The background image represents an average of a number of preceding images. This yields an image ΔI_n that
25 contains only those objects that have moved during the time interval between images. The image ΔI_n is thresholded at appropriate values to yield a binary image, i.e. one that contains only two levels of brightness, such that the pixels comprising the edges of the aircraft are clearly distinguishable. The pixels at the extremes of the aircraft in the direction perpendicular to the motion of the aircraft will correspond to the edges
30 of the wings of the aircraft. After further processing, described below, when it is determined the pixels comprising the port edge pass a certain position in the image

- 11 -

corresponding to the acquisition point, the acquisition system 10 is triggered, thereby obtaining an image of the registration code beneath the wing 20 of the aircraft.

Imaging the aircraft using thermal infrared wavelengths and detecting the
5 aircraft by its thermal radiation renders the aircraft self-luminous so that it can be imaged both during the day and night primarily without supplementary illumination. Infrared (IR) detectors are classified as either photon detectors (termed cooled sensors herein), or thermal detectors (termed uncooled sensors herein). Photon detectors (photoconductors or photodiodes) produce an electrical response directly
10 as the result of absorbing IR radiation. These detectors are very sensitive, but are subject to noise due to ambient operating temperatures. It is usually necessary to cryogenically cool (80°K) these detectors to maintain high sensitivity. Thermal detectors experience a temperature change when they absorb IR radiation, and an electrical response results from temperature dependence of the material property.
15 Thermal detectors are not generally as sensitive as photon detectors, but perform well at room temperature.

Typically, the cooled sensing devices are formed from Mercury Cadmium Telluride offer far greater sensitivity than uncooled devices, which may be formed from
20 Barium Strontium Titanate. Their Net Equivalent Temperature Difference (NETD) is also superior. However, with the uncooled sensor a chopper can be used to provide temporal modulation of the scene. This permits AC coupling of the output of each pixel to remove the average background. This minimises the dynamic range requirements for the processing electronics and amplifies only the temperature differences. This is
25 an advantage for resolving differences between cloud, the sun, the aircraft and the background. The advantage of differentiation between objects is that it reduced the load on subsequent image processing tasks for segmenting the aircraft from the background and other moving objects such as the clouds.

30 Both a cooled and uncooled thermal infrared imaging system 6 has been used during day, night and foggy conditions. The system 6 produced consistent images of

- 12 -

the aircraft in all these conditions, as shown in Figures 8 and 9. In particular, the sun in the field of view produced no saturation artefacts or flaring in the lens. At night, the entire aircraft was observable, not just the lights.

5 The image processing system 8 uses a background subtraction method in an attempt to eliminate slowly moving or stationary objects from the image, leaving only the fast moving objects. This is achieved by maintaining a background image that is updated after a certain time interval elapses. The update is an incremental one based on the difference between the current image and the background. The incremental
10 change is such that the background image can adapt to small intensity variations in the scene but takes some time to respond to large variations. The background image is subtracted from the current image, a modulus is taken and a threshold applied. The result is a binary image containing only those differences from the background that exceed the threshold.

15

One problem with this method is that some slow moving features, such as clouds, still appear in the binary image. The reason for this is that the method does not select on velocity but on a combination of velocity and intensity gradients. If the intensity in the image is represented by $I(x,y,t)$, where x and y represent the position
20 in rows and columns, respectively, and t represents the image frame number (time) and if the variation in the intensity due to ambient conditions is very small then it can be shown that the time variation of the intensity in the image due to a feature moving with velocity v is given by

$$\frac{\partial I(x,y,t)}{\partial t} = -v \cdot \nabla I(x,y,t) \quad (7)$$

In practice, the time derivative in equation (7) is performed by taking the
25 difference between the intensity at (x,y) at different times. Equation (7) shows that the value of this difference depends on the velocity v of the feature at (x,y) and the intensity gradient. Thus a fast moving feature with low contrast relative to the background is identical to a slow moving feature with a large contrast. This is the

- 13 -

situation with slowly moving clouds that often have very bright edges and therefore large intensity gradients there, and are not eliminated by this method. Since features in a binary image have the same intensity gradients, better velocity selection is obtained using the same method but applied to the binary image. In this sense, the background-subtraction method is applied twice, once to the original grey-scale image to produce a binary image as described above, and again to the subsequent binary image, as described below.

The output from the initial image processing hardware is a binary image $B(x,y,t)$ where $B(x,y,t) = 1$ if a feature is located at (x,y) at time t , and $B(x,y,t) = 0$ represents the background. Within this image the fast moving features belong to the aircraft. To deduce the aircraft wing position the two-dimensional binary image can be compressed into one dimension by summing along each pixel row of the binary image,

$$P(y,t) = \int B(x,y,t) dx \quad (8)$$

where the aircraft image moves in the direction of the image columns. This row-sum profile is easily analysed in real time to determine the location of the aircraft. An example of a profile is shown in Figure 10 where the two peaks 30 and 31 of the aircraft profile correspond to the main wings (large peak 30) and the tail wings (smaller peak 31).

In general, there are other features present, such as clouds, that must be identified or filtered from the profile. To do this, differences between profiles from successive frames are taken, which is equivalent to a time derivative of the profile. Letting $A(x,y,t)$ be the aircraft where $A(x,y,t) = 1$ if (x,y) lies within the aircraft and 0 otherwise and letting $C(x,y,t)$ represent clouds or other slowly moving objects, then it can be shown that the time derivative of the profile is given by

$$\begin{aligned} \frac{\partial P(y,t)}{\partial t} &= \int \frac{\partial A(x,y,t)}{\partial t} dx + \int \frac{\partial C(x,y,t)}{\partial t} dx - \int \frac{\partial}{\partial t} [A(x,y,t)C(x,y,t)] dx \\ &= \int \frac{\partial A(x,y,t)}{\partial t} [1 - C(x,y,t)] dx + \varepsilon(C) \end{aligned} \quad (9)$$

- 14 -

where $\varepsilon(C) \approx 0$ is a small error term due to the small velocity of the clouds. Equation (9) demonstrates an obvious fact that the time derivative of a profile gives information on the changes (such as motion) of feature A only when the changes in A do not overlap features C . In order to obtain the best measure of the location of a feature, the
5 overlap between features must be minimised. This means that $C(x,y,t)$ must cover as small an area as possible. If the clouds are present but do not overlap the aircraft, then apart from a small error term, the time difference between profiles gives the motion of the aircraft. The difference profile corresponding to Figure 10 is shown in Figure 11 where the slow moving clouds have been eliminated. The wing positions
10 occur at the zero-crossing points 33 and 34. Note that the clouds have been removed, apart from small error terms.

The method is implemented using a programmable logic circuit of the image processing system 8 which is programmed to perform the row sums on the binary
15 image and to output these as a set of integers after each video field. When taking the difference between successive profiles the best results were obtained using differences between like fields of the video image, i.e. even-even and odd-odd fields.

The difference profile is analysed to locate valid zero crossing points
20 corresponding to the aircraft wing positions. A valid zero crossing is one in which the difference profile initially rises above a threshold I_T for a minimum distance y_T and falls through zero to below $-I_T$ for a minimum distance y_T . The magnitude of the threshold I_T is chosen to be greater than the error term $\varepsilon(C)$ which is done to discount the affect produced by slow moving features, such as clouds.

25

In addition, the peak value of the profile, corresponding to the aircraft wing, can be obtained by summing the difference values when they are valid up to the zero crossing point. This method removes the contributions to the peak from the non-overlapping clouds. It can be used as a guide to the wing span of the aircraft.

30

The changes in position of the aircraft in the row-sum profile are used to

- 15 -

determine a velocity for the aircraft that can be used for determining the image acquisition or trigger time, even if the aircraft is not in view. This situation may occur if the aircraft image moves into a region on the sensor that is saturated, or if the trigger point is not in the field of view of the camera 3. However, to obtain a reliable estimate
5 of the velocity, geometric corrections to the aircraft position are required to account for the distortions in the image introduced by the camera lens. These are described below using the coordinate systems (x,y,z) for the image and (X,Y,Z) for the aircraft as shown in Figures 12 and 13, respectively.

- 10 For an aircraft at distance Z and at a constant altitude Y_0 , the angle from the horizontal to the aircraft in the vertical plane is

$$\tan\theta_y = \frac{Y_0}{Z} \quad (10)$$

Since Y_0 is approximately constant, a normalised variable $Z_N = Z/Y_0$ can be used. If y_0 is the coordinate of the centre of the images, f is the focal length of the lens and θ_c is the angle of the camera from the horizontal in the vertical plane, then

$$\frac{y_0 - y}{f} = \tan(\theta_y - \theta_c) = \frac{\tan\theta_y - \tan\theta_c}{1 + \tan\theta_y \tan\theta_c} \quad (11)$$

- 15 where the tangent has been expanded using a standard trigonometric identity. Using (10) and (11) an expression for the normalised distance Z_N is obtained

$$Z_N(y) = \frac{1 + \beta(y - y_0)\tan\theta_c}{\tan\theta_c - \beta(y - y_0)} \quad (12)$$

where $\beta = 1/f$. This equation allows a point in the image at y to be mapped onto a true distance scale, Z_N . Since the aircraft altitude is unknown, the actual distance cannot be determined. Instead, all points in the image profile are scaled to be
20 equivalent to a specific point, y_1 , in the profile. This point is chosen to be the trigger line or image acquisition line. The change in the normalised distance $Z_N(y_1)$ at y_1 due to an increment in pixel value Δy_1 is $\Delta Z_N(y_1) = Z_N(y_1 + \Delta y_1) - Z_N(y_1)$. The number

of such increments over a distance $Z_N(y_2) - Z_N(y_1)$ is $M = (Z_N(y_2) - Z_N(y_1))/\Delta Z_N(y_1)$. Thus the geometrically corrected pixel position at y_2 is

$$y_{c2} = y_1 + M\Delta y_1 = y_1 + \frac{Z_N(y_2) - Z_N(y_1)}{\Delta Z_N(y_1)} \Delta y_1 \tag{13}$$

For an aircraft at distance Z and at altitude Y_0 , a length X on it in the X direction subtends an angle in the horizontal plane of

$$\tan\theta_x = \frac{X}{\sqrt{Y_0^2 + Z^2}} = \frac{X_N}{\sqrt{1 + Z_N^2}} \tag{14}$$

5 where normalised values have been used. If x_0 is the location of the centre of the image and f is the focal length of the lens, then

$$\frac{x - x_0}{f} = \tan\theta_x \tag{15}$$

Using (12), (14) and (15), the normalised distance X_N can be obtained in terms of x and y

$$X_N = \frac{(x - x_0)}{f} \sqrt{1 + Z_N^2(y)} \tag{16}$$

As with the y coordinate, the x coordinate is corrected to a value at y_1 . Since X_N 10 should be independent of position, then a length $x_2 - x_0$ at y_2 has a geometrically corrected length of

$$\begin{aligned} x_{c2} - x_0 &= (x_2 - x_0) \frac{\sqrt{1 + Z_N^2(y_2)}}{\sqrt{1 + Z_N^2(y_1)}} \\ &= (x_2 - x_0) \frac{\sqrt{1 + \beta^2(y_2 - y_0)^2} \sin\theta_c - \beta(y_1 - y_0)\cos\theta_c}{\sin\theta_c - \beta(y_2 - y_0)\cos\theta_c \sqrt{1 + \beta^2(y_1 - y_0)^2}} \end{aligned} \tag{17}$$

The parameter $\beta = 1/f$ is chosen so that x and y are measured in terms of pixel numbers. If y_0 is the centre of the camera centre and it is equal to half the total number of pixels, and if θ_{FOV} is the vertical field of view of the camera, then

- 17 -

$$\beta = \frac{\tan(\theta_{FOV}/2)}{y_0} \quad (18)$$

This relation allows β to be calculated without knowing the lens focal length and the dimensions of the sensor pixels.

The velocity of a feature is expressed in terms of the number of pixels moved between image fields (or frames). Then if the position of the feature in frame n is y_n , the velocity is given by $v_n = y_n - y_{n-1}$. Over N frames, the average velocity is then

$$\langle v \rangle = \frac{1}{N} \sum_{n=1}^N v_n = \frac{1}{N} \sum_{n=1}^N (y_n - y_{n-1}) = \frac{1}{N} (y_N - y_0) \quad (19)$$

which depends only on the start and finish points of the data. This is sensitive to errors in the first and last values and takes no account of the positions in between. The error in the velocity due to an error δy_N in the value y_N is

$$e(\langle v \rangle) = \frac{\delta y_N}{N} \quad (20)$$

10 A better method of velocity estimation uses all the position data obtained between these values. A time t is maintained which represents the current frame number. Then the current position is given by

$$y = y_0 - vt \quad (21)$$

where y_0 is the unknown starting point and v is the unknown velocity. The number n of valid positions y_n measured from the feature are each measured at time t_n .

15 Minimising the mean square error

$$\chi^2 = \frac{1}{N} \sum_{n=1}^N (y_n - y_0 + vt_n)^2 \quad (22)$$

with respect to v and y_0 gives two equations for the unknown quantities y_0 and v . Solving for v yields

- 18 -

$$v = \frac{\sum_{n=1}^N y_n \sum_{n=1}^N t_n - N \sum_{n=1}^N y_n t_n}{N \sum_{n=1}^N t_n^2 - \sum_{n=1}^N t_n \sum_{n=1}^N t_n} \quad (23)$$

This solution is more robust in the sense that it takes account of all the motions of the feature, rather than the positions at the beginning and at the end of the observations. If the time is sequential, so that $t_n = n\Delta t$ where $t_n = 1$ is the time interval between image frames, then the error in the velocity due to an error δy_n in the value y_n is

$$\varepsilon(\langle v \rangle) = \frac{\delta y_n \{6(N+1-2n)\}}{N \{(N+1)(N-1)\}} \quad (24)$$

5 which, for the same error δy_n in (19), gives a smaller error than (21) for $N > 5$. In general, the error in (24) varies as $1/N^2$ which is less sensitive to uncertainties in position than (19).

If the aircraft is not in view, then the measurement of the velocity v can be used
10 to estimate the trigger time. If y_l is the position of a feature on the aircraft that was last seen at a time t_l , then the position at any time t is estimated from

$$y = y_l - v(t - t_l) \quad (25)$$

Based on this estimate of position, the aircraft will cross the trigger point located at y_T at a time t_T estimated by

$$t_T = t_l - \frac{y_T - y_l}{v} \quad (26)$$

An alternative method of processing the images obtained by the camera 3 to
15 determine the aircraft position, which also automatically accounts for geometric corrections, is described below. The method is able to predict the time for triggering the acquisition system 10 based on observations of the position of the aircraft 28.

To describe the location of an aircraft 28 and its position, a set of coordinates are defined such that the \hat{x} axis points vertically upwards, the \hat{z} axis points horizontally along the runway towards the approaching aircraft, and \hat{y} is horizontal and perpendicular to the runway. The image 66 of the aircraft is located in the digitised
 5 image by pixel values (x_p, y_p) , where x_p is defined to be the vertical pixel value and y_p the horizontal value. The lens on the camera inverts the image so that a light ray from the aircraft strikes the sensor at position $(-x_p, -y_p, 0)$, where the sensor is located at the coordinate origin. Figure 14 shows a ray 68 from an object, such as a point on the
 10 aircraft, passing through a lens of a focal length f , and striking the imaging sensor at a point $(-x_p, -y_p)$, where x_p and y_p are the pixel values. The equation locating a point on the ray is given by

$$r = x_p(z/f - 1)\hat{x}_c + y_p(z/f - 1)\hat{y}_c + z\hat{z}_c \quad (27)$$

where z is the horizontal distance along the ray, and the subscript c refers to the camera coordinates. The camera axis \hat{z}_c is collinear with the lens optical axis. It will be assumed that $z/f \gg 1$, which is usually the case.

15

Assuming the camera is aligned so that $\hat{y}_c = \hat{y}$ is aligned with the runway coordinate, but the camera is tilted from the horizontal by angle θ . Then

$$\begin{aligned} \hat{x}_c &= \hat{x} \cos\theta - \hat{z} \sin\theta \\ \hat{z}_c &= \hat{x} \sin\theta + \hat{z} \cos\theta \end{aligned} \quad (28)$$

and a point on the ray from the aircraft to its image is given by

$$r = z[(x_p \cos\theta / f + \sin\theta) \hat{x} + (y_p / f) \hat{y} + (\cos\theta - x_p \sin\theta / f) \hat{z}] \quad (29)$$

Letting the aircraft trajectory be given by

$$r(t) = (z(t) \tan\theta_{GS} + x_0) \hat{x} + y_0 \hat{y} + z(t) \hat{z} \quad (30)$$

20 where $z(t)$ is the horizontal position of the aircraft at time t , θ_{GS} is the glide-slope angle, and the aircraft is at altitude x_0 and has a lateral displacement y_0 at $z(t_0) = 0$. Here, $t = t_0$ is the time at which the image acquisition system 10 is triggered, i.e. when

- 20 -

the aircraft is overhead with respect to the cameras 7.

Comparing equations (29) and (30) allows z to be written in terms of $z(t)$ and gives the pixel positions as

$$x_p(t) = f \left(\frac{z(t)[\cos\theta \tan\theta_{GS} - \sin\theta] + x_0 \cos\theta}{z(t)[\sin\theta \tan\theta_{GS} + \cos\theta] + x_0 \sin\theta} \right) \quad (31)$$

5 and

$$y_p(t) = \frac{fy_0}{z(t)[\sin\theta \tan\theta_{GS} + \cos\theta] + x_0 \sin\theta} \quad (32)$$

Since $z_p(t)$ is the vertical coordinate and its value controls the acquisition trigger, the following discussion will be centred on equation (31). The aircraft position is given by

$$z(t) = v(t_0 - t) \quad (33)$$

where v is the speed of the aircraft along the \hat{z} axis.

10

The aim is to determine t_0 from a series of values of $z_p(t)$ at t determined from the image of the aircraft. For this purpose, it is useful to rearrange (31) into the following form

$$c - t + ax_p - bt_x = 0 \quad (34)$$

where

$$a = \frac{vt_0(\tan\theta_{GS} + \cot\theta) + x_0}{f(1 - \tan\theta_{GS} \cot\theta)} \quad (35)$$

$$b = \frac{\tan\theta_{GS} + \cot\theta}{f(1 - \tan\theta_{GS} \cot\theta)} \quad (36)$$

15 and

- 22 -

Then the values of a , b and c that minimise equation (39) are given by

$$a = \frac{(NP - XT)(P^2 - NS) - (NR - PT)(PX - NQ)}{(NY - X^2)(P^2 - NS) + (PX - NQ)^2} \quad (41)$$

$$b = \frac{(NP - XT)(PX - NQ) + (NR - PT)(NY - X^2)}{(NY - X^2)(P^2 - NS) + (PX - NQ)^2} \quad (42)$$

and

$$c = \frac{T + bP - aX}{N} \quad (43)$$

On obtaining a , b and c from equations (41) to (43), then t_0 can be obtained from equation (38).

5

Using data obtained from video images of an aircraft landing at Melbourne airport, a graph of aircraft image position as a function of image frame number is shown in Figure 15. The data was processed using equations (41) to (43) and (38) to yield the predicted value for the trigger frame number $t_0 = 66$ corresponding to trigger point 70. The predicted point 70 is shown in Figure 16 as a function of frame number. The predicted value is $t_0 = 66 \pm 0.5$ after 34 frames. In this example, the aircraft can be out of the view of the camera 3 for up to 1.4 seconds and the system 2 can still trigger the acquisition camera 7 to within 40 milliseconds of the correct time. For an aircraft travelling at 62.5 m/s, the system 2 captures the aircraft to within 2.5 metres
15 of the required position.

The tracking system 6, 8 may also use an Area-Parameter Accelerator (APA) digital processing unit, as discussed in International Publication No. WO 93/19441, to extract additional information, such as the aspect ratio of the wing span to the
20 fuselage length of the aircraft and the location of the centre of the aircraft.

The tracking system 1 can also be implemented using one or more pyroelectric sensors 27 with a signal processing wing detection unit 29. Each sensor 27 has two

- 23 -

adjacent pyroelectric sensing elements 40 and 42, as shown in Figure 17, which are electrically connected so as to cancel identical signals generated by each element. A plate 44 with a slit 46 is placed above the sensing elements 40 and 42 so as to provide the elements 40 and 42 with different fields of view 48 and 50. The fields of view 48 and 50 are significantly narrower than the field of view of a detection camera discussed previously. If aircraft move above the runway in the direction indicated by the arrow 48, the first element 40 has a front field of view 48 and the second element 42 has a rear field of view 50. As an aircraft 28 passes over the sensor 27 the first element 40 detects the thermal radiation of the aircraft before the second element 42, the aircraft 28 will then be momentarily in both fields of view 48 and 50, and then only detectable by the second element 42. An example of the difference signals generated by two sensors 27 is illustrated in Figure 18 where the graph 52 is for a sensor 27 which has a field of view that is directed at 90° to the horizontal and a sensor 27 which is directed at 75° to the horizontal. Graph 54 is an expanded view of the centre of graph 52. The zero crossing points of peaks 56 in the graphs 52 and 54 correspond to the point at which the aircraft 28 passes the sensor 27. Using the known position of the sensor 27 the time at which the aircraft passes, and the speed of the aircraft 28, a time can be determined for generating an acquisition signal to trigger the high resolution acquisition cameras 7. The speed can be determined from movement of the zero crossing points over time, in a similar manner to that described previously.

The image acquisition system 10, as mentioned previously, acquires an image of the aircraft with sufficient resolution for the aircraft registration characters to be obtained using optical character recognition. According to one embodiment of the acquisition system 10, the system 10 includes two high resolution cameras 7 each comprising a lens and a CCD detector array. Respective images obtained by the two cameras 7 are shown in Figures 19 and 20.

The minimum pixel dimension and the focal length of the lens determine the spatial resolution in the image. If the dimension of a pixel is L_p , the focal length f and the altitude of the aircraft is h , then the dimension of a feature W_{\min} on the aircraft that

- 24 -

is mapped onto a pixel is

$$W_{\min} = \frac{L_p h}{f} \quad \text{or} \quad f = \frac{L_p h}{W_{\min}} \quad (44)$$

The character recognition process used requires each character stroke to be mapped onto at least four pixels with contrast levels having at least 10% difference from the background. The width of a character stroke in the aircraft registration is 5 regulated by the ICAO. According to the ICAO Report, Annex 7, sections 4.2.1 and 5.3, the character height beneath the port wing must be at least 50 centimetres and the character stroke must be 1/6th the character height. Therefore, to satisfy the character recognition criterion, the dimension of the feature on the aircraft that is mapped onto a pixel should be $W_{\min} = 2$ centimetres, or less. Once the CCD detector 10 is chosen, L_p is fixed and the focal length of the system 10 is determined by the maximum altitude of the aircraft at which the spatial resolution $W_{\min} = 2$ centimetres is required.

The field of view of the system 10 at altitude h is determined by the spatial 15 resolution W_{\min} chosen at altitude h_{\max} and the number of pixels N_{pl} along the length of the CCD,

$$W_{FOV} = \frac{N_{pl} W_{\min} h}{h_{\max}} \quad (45)$$

For $h = h_{\max}$ and $N_{pl} = 1552$ the field of view is $W_{FOV} = 31.04$ metres.

To avoid blurring due to motion of the aircraft, the image moves a distance less 20 than the size of a pixel during the exposure. If the aircraft velocity is v , then the time to move a distance equal to the required spatial resolution W_{\min} is

$$t = \frac{W_{\min}}{v} \quad (46)$$

The maximum aircraft velocity that is likely to be encountered on landing or

- 25 -

take-off is $v = 160 \text{ knots} = 82 \text{ ms}^{-1}$. With $W_{\min} = 0.02 \text{ m}$, the exposure time to avoid excessive blurring is $t < 240 \mu\text{s}$.

The focal length of the lens in the system 10 can be chosen to obtain the 5 required spatial resolution at the maximum altitude. This fixes the field of view. Alternatively, the field of view may be varied by altering the focal length according to the altitude of the aircraft. The range of focal lengths required can be calculated from equation (44)

10 The aircraft registration, during daylight conditions, is illuminated by sunlight or scattered light reflected from the ground. The aircraft scatters the light that is incident, some of which is captured by the lens of the imaging system. The considerable amount of light reflected from aluminium fuselages of an aircraft can affect the image obtained, and is taken into account. The light power falling onto a 15 pixel of the CCD is given by

$$P_p = L_\lambda \Delta\lambda \Omega_{\text{sun}} \frac{R_{\text{gnd}} R_A A_p}{8f\#^2} \quad (47)$$

where L_λ is the solar spectral radiance, $\Delta\lambda$ is the wavelength bandpass of the entire configuration, Ω_{sun} is the solid angle subtended by the sun, R_{gnd} is the reflectivity of the ground, R_A is the reflectivity of the aircraft, A_p is the area of a pixel in the CCD detector and $f\#$ is the lens f-number.

20

The solar spectral radiance L_λ varies markedly with wavelength λ . The power falling on a pixel will therefore vary over a large range. This can be limited by restricting the wavelength range $\Delta\lambda$ passing to the sensor and optimally choosing the centre wavelength of this range. The optimum range and centre wavelength are 25 chosen to match the characteristics of the imaging sensor.

In one embodiment, the optimum wavelength range and centre wavelength are chosen in the near infrared waveband, 0.69 to 2.0 microns. This limits the variation in

- 26 -

light power on a pixel in the sensor to within the useable limits of the sensor. A KODAK™ KAF-1600L imaging sensor (a monolithic silicon sensor with lateral overflow anti-blooming) was chosen that incorporated a mechanism to accommodate a thousandfold saturation of each pixel, giving a total acceptable range of light powers 5 in each pixel of 10^5 . This enables the sensor to produce a useful image of an aircraft when very bright light sources, for example the sun, are in its field of view.

The correct choice of sensor and the correct choice of wavelength range and centre wavelength enables an image to be obtained within a time interval that arrests 10 the motion of the aircraft and that provides an image with sufficient contrast on the aircraft registration to enable digital image processing and recognition of the registration characters.

In choosing the wavelength range and centre wavelength, it was important to 15 avoid dazzling light from the supplementary illumination of the illumination unit 16. The optimum wavelength range was therefore set to between $0.69 \mu\text{m}$ and $2.0 \mu\text{m}$.

The power of sunlight falling onto a pixel directly from the sun is

$$P_{p\text{-sun}} = L_{\lambda} \Delta\lambda \frac{A_p \pi}{4f\#^2} \quad (48)$$

The relative light powers from the sun and from the aircraft registration falling 20 onto a single pixel is

$$\frac{P_{p\text{-sun}}}{P_p} = \frac{2\pi}{\Omega_{\text{sun}} R_{\text{gnd}} R_A} \quad (49)$$

With $\Omega_{\text{sun}} = 6.8 \times 10^{-5}$ steradians, $R_{\text{gnd}} \approx 0.2$ and $R_A = 1$, the ratio is $P_{p\text{-sun}}/P_p = 4.6 \times 10^5$. This provides an estimate of the relative contrast between the image of the sun and the image of the underneath of the aircraft on a CCD pixel. The CCD sensor and system electronics are chosen to accommodate this range of light 25 powers.

- 27 -

In poor lighting conditions, the aircraft registration requires additional illumination from the illumination unit 16. The light source of the unit 16 needs to be sufficient to illuminate the aircraft at its maximum altitude. If the source is designed to emit light into a solid angle that just covers the field of view of the imaging system then
 5 the light power incident onto a pixel of the imaging system 10 due to light emitted from the source and reflected from the aircraft is given by

$$P_p = P_s \frac{R_A}{8A_A} \frac{A_p}{N_{\text{ptot}} \#^2} \quad (50)$$

where A_A is the area on the aircraft imaged onto a pixel of area A_p , P_s is the light power of the source, R_A is the aircraft reflectivity, N_{ptot} is the total number of pixels in the CCD sensor and $\#$ is the f-number of the lens. The power of the source required
 10 to match the daytime reflected illumination is estimated by setting $P_p = 7.3 \times 10^{-11}$ W, $R_A = 1$, $A_p = 81 \mu\text{m}^2$, $N_{\text{ptot}} = 1552 \times 1032$, $\# = 1.8$ and noting that $A_A = W_{\text{min}}^2$ where $W_{\text{min}} = 0.02$ m. Then $P_s = 1.50 \times 10^4$ W. For a Xenon flash lamp, the flash time is typically $t = 300 \mu\text{s}$ which compares favourably with the exposure time to minimise motion blurring. Then the source must deliver an energy of
 15 $E_s = P_s t = 4.5$ J. This is the light energy in a wavelength band $\Delta\lambda = 0.1 \mu\text{m}$. Xenon flash lamps typically have 10% of their light energy within this bandpass centred around $\lambda = 0.8 \mu\text{m}$. Furthermore, the flash lamp may only be 50% efficient. Thus the electrical energy required is approximately 90 J. Flash lamps that deliver energies of 1500 J in 300 μs are readily available. Illumination with such a flash lamp during the
 20 day reduces the contrast between the direct sun and the aircraft registration, thereby relaxing the requirement for over-exposure tolerance of the CCD sensor. This result depends on the flash lamp directing all of its energy into the field of view only and that the lens focal length is optimally chosen to image the region of dimension $W_{\text{min}} = 0.02$ m onto a single pixel.

25

In one embodiment, the aperture of the lens on the acquisition camera 7 is automatically adjusted to control the amount of light on the imaging sensor in order to optimise the image quality for digital processing. In the image obtained, the intensity

- 28 -

level of the registration characters relative to the underside of the aircraft needs to be maintained to provide good contrast between the two for OCR. The power P_s of the flash 16 is automatically adjusted in accordance with the aperture setting $f\#$ of the acquisition camera 7 to optimise the image quality and maintain the relative contrast 5 between the registration characters and the underside of the aircraft, in accordance with the relationship expressed in equation (50). For example, during the day the aperture of the lens may be very small and the power of the flash may be increased to provide additional illumination of the underside, whereas during night conditions, the aperture may be fully opened and the power of the flash reduced considerably as 10 additional illumination is not required. As an alternative, or in addition, the electrical gain of the electronic circuits connected to an acquisition camera 7 is adjusted automatically to optimise the image quality.

To appropriately set the camera aperture and/or gain one or more point optical 15 sensors 60, 62, as shown in Figure 21, are used to measure the ambient lighting conditions. The electrical output signals of the sensors 60, 62 are processed by the acquisition system 10 to produce the information required to control the camera aperture and/or gain. Two point sensors 60, 62 sensitive to the same optical spectrum as the acquisition cameras 7 can be used. One sensor 60 receives light from the sky 20 that passes through a diffusing plate 64 onto the sensor 60. The diffusing plate 64 collects light from many different directions and allows it to reach the sensor 60. The second sensor 62 is directed towards the ground to measure the reflected light from the ground.

25 The high resolution images obtained of the aircraft by the acquisition system 10 are submitted, as described previously, to the analysis system 12 which performs optical character recognition on the images to extract the registration codes of the aircraft.

30 The analysis system 12 processes the aircraft images obtained by a high resolution camera 7 according to an image processing procedure 100, as shown in

- 29 -

Figure 22, which is divided into two parts 102 and 104. The first part 102 operates on a sub-sampled image 105, as shown in Figure 23, to locate regions that contain features that may be registration characters, whereas the second part 104 executes a similar procedure but is done using the full resolution of the original image and is
5 executed only on the regions identified by the first part 102. The sub-sampled image 105 is the original image with one pixel in four removed in both row and column directions, resulting in a one in sixteen sampling ratio. Use of the sub-sampled image improves processing time sixteen-fold.

10 The first part 102 receives the sub-sampled image at step 106 and filters the image to remove features which are larger than the expected size of the registration characters (b) at step 108. Step 108 executes a morphological operation of linear closings applied to a set of lines angled between 0 and 180°. The operation passes a kernel or window across the image 105 to extract lines which exceed a
15 predetermined length and are at a predetermined angle. The kernel or window is passed over the image a number of times and each time the predetermined angle is varied. The lines extracted from all of the passes are then subtracted from the image 105 to provide a filtered difference image 109. The filtered difference image 109 is then thresholded or binarised at step 110 to convert it from a grey scale image to a
20 binary scale image 111. This is done by setting to 1 all image values that are greater than a threshold and setting to 0 all other image values. The threshold at a given point in the image is determined from a specified multiple of standard deviations from the mean calculated from the pixel values within a window centred on the given point. The binarised image 111 is then filtered at step 112 to remove all features that have pixel
25 densities in a bounding box that are smaller or larger than the expected pixel density for a bounded registration character. The image 111 is then processed at step 114 to remove all features which are not clustered together like registration characters. Step 114 achieves this by grouping together features that have similar sizes and that are close to one another. Groups of features that are smaller than a specified size are
30 removed from the image to obtain a cleaned image 113. The cleaned image 113 is then used at step 116 to locate regions of interest. Regions of interest are obtained

- 30 -

in step 116 from the location and extents of the groups remaining after step 114. Step 116 produces regions of interest which include the registration characters and areas of the regions are bounded above and below, as for the region 115 shown in Figure 23.

5

The regions of interest obtained by the first part 102 of the procedure 100 are further processed individually using the full resolution of the original image and the second part 104 of the procedure. The second part 104 takes a region of interest 115 from the original image at step 120 and for that region filters out features larger than 10 the expected character sizes at step 122, using the same morphological operation of linear closings applied to a set of lines angled between 0 and 180°, followed by image subtraction, as described above, to obtain image 117. The filtered image 117 is then binarised at step 124 by selecting a filter threshold that is representative of the pixel values at the edges of features. To distinguish the registration characters from the 15 aircraft wing or body the filter threshold needs to be set correctly. A mask image of significant edges in image 117 is created by calculating edge-strengths at each point in image 117 and setting to 1 all points that have edge-strengths greater than a mask threshold and setting to 0 all other points. An edge-strength is determined by taking at each point pixel gradients in two directions, Δx and Δy , and calculating 20 $\sqrt{\Delta x^2 + \Delta y^2}$ to give the edge-strength at that point. The mask threshold at a given point is determined from a specified multiple of standard deviations from the mean calculated from the edge-strengths within a window centred on the given point. The filter threshold for each point in image 117 is then determined from a specified multiple 25 of standard deviations from the mean calculated from the pixel values at all points within a window centred on the given point that correspond to non-zero values in the mask image. The binarised image 118 is then filtered at step 126 to remove features that are smaller than the expected character sizes. Features are clustered together at step 128 that have similar sizes, that are near to one another and that are associated with similar image values in image 117. At step 130 the correctly clustered features 30 that have sizes, orientations and relative positions that deviate too much from the averages for the clusters are filtered out to leave features that form linear chains. Then

- 31 -

at step 132, if the number of features remaining in the image produced by step 130 is greater than 3, then a final image is created by rotating image 118 to align the linear chain of features with the image rows and by masking out features not belonging to the linear chain. The final image is passed to a character recognition process 200 to
5 determine whether the features are registration characters and, if so, which characters.

The final image undergoes a standard optical character recognition process 200, as shown in Figure 24, to generate character string data which represents the
10 ICAO characters on the port wing. The process 200 includes receiving the final image at step 202, which is produced by step 132 of the image processing procedure 100, and separating the characters of the image at step 204. The size of the characters are normalised at step 206 and at step 208 correction for the alignment of the characters is made and further normalisation occurs. Character features are extracted at step 210
15 and an attempt made to classify the features of the characters extracted at step 212. Character rules are applied to the classified features at step 214 so as to produce a binary string representative of the registration characters at step 216.

Although the system 2 has been described above as being one which is
20 particularly suitable for detecting an aircraft, it should be noted that many features of the system can be used for detecting and identifying other moving objects. For example, the embodiments of the tracking system 1 may be used for tracking land vehicles. The system 2 may be employed to acquire images of and identify automobiles at tollway points on a roadway.

25

Many modifications will be apparent to those skilled in the art without departing from the scope of the present invention as hereinbefore described with reference to the accompanying drawings.

30

- 32 -

CLAIMS:

1. An object detection system including:
passive sensing means for receiving electromagnetic radiation from a moving
5 object and generating intensity signals representative of the received radiation; and
processing means for subtracting said intensity signals to obtain a differential
signature representative of the position of said moving object.
2. An object detection system as claimed in claim 1, wherein said processing
10 means generates an image acquisition signal on the basis of said differential
signature.
3. An object detection system as claimed in claim 2, including acquisition means,
responsive to said acquisition signal, for acquiring an image of at least part of said
15 moving object; and
analysis means for processing said image to identify said moving object.
4. An object detection system as claimed in claim 3, wherein said analysis system
processes said acquired image to extract markings to identify said moving object
20
5. An object detection system as claimed in claim 1, 2, 3 or 4, wherein said moving
object is an aircraft.
6. An object detection system as claimed in claim 5, wherein said aircraft is in
25 flight.
7. An object detection system as claimed in claim 5, wherein said electromagnetic
radiation is thermal radiation.

30

- 33 -

8. An object detection system as claimed in claim 5, including proximity detecting means for detecting the presence of said aircraft within a predetermined region and, in response thereto, generating an activation signal for said passive sensing means.
- 5 9. An object detection system as claimed in claim 1, wherein said passive sensing means includes imaging means for obtaining images of said radiation at successive periods of time, and
said processing means generates respective profiles of pixel values for said images and a difference profile, generated from the difference between successive
10 profiles, which includes said differential signature.
10. An object detection system as claimed in claim 9, wherein said position corresponds to a zero crossing point in said difference profile where said difference profile has risen above a first predetermined threshold for at least a first predetermined
15 distance and then falls to below a second predetermined threshold for a second predetermined distance.
11. An object detection system as claimed in claim 10, wherein said processing means monitors the movement of said position in successive ones of said difference
20 profile and determines the time for generation of an image acquisition signal.
12. An object detection system as claimed in claim 11, wherein said processing means generates a background image from successive images obtained by said imaging means and subtracts said background image from images of said radiation
25 before generating said profiles.
13. An object detection system as claimed in claim 1, wherein said passive sensing means includes pyroelectric sensors with different fields of view and said intensity signals include at least first and second signals representative of the thermal radiation
30 present in said views, respectively, and

- 34 -

said processing means subtracts said first and second signals to obtain a differential signal including said differential signature.

14. An object detection system as claimed in claim 13, wherein said processing
5 means determines a time for generation of an image acquisition signal on the basis of the position of said passive sensing means, the time of generation of said differential signature and the speed of said moving object.
15. An object detection system as claimed in claim 14, wherein said time of
10 generation and said speed are determined from a zero crossing point of said differential signature.
16. An image acquisition system including:
at least one camera for acquiring an image of at least part of a moving object,
15 in response to a trigger signal, and
analysis means for processing said image to locate a region in said image including markings identifying said object and processing said region to extract said markings for a recognition process.
- 20 17. An image acquisition system as claimed in claim 16, wherein said camera images received radiation between 0.69 to 2.0 μm .
18. An image acquisition system as claimed in claim 17, wherein said camera has an exposure time of $< 240 \mu\text{s}$.
- 25 19. An image acquisition system as claimed in claim 17, including an infrared flash having its power adjusted on the basis of the aperture setting of said camera.
20. An image acquisition system as claimed in claim 17, including optical sensor
30 means positioned to obtain measurements of ambient direct light and reflected light for the field of view of said camera and adjust settings of said camera on the basis of said measurements.

- 35 -

21. An image acquisition system as claimed in claim 16, wherein said analysis means sub-samples said image, extracts lines exceeding a predetermined length and at predetermined angles, binarises the image, removes features smaller or larger than said markings, removes features not clustered as said markings, and locates said
5 region using the remaining features.

22. An image acquisition system as claimed in claim 21, wherein said analysis means extracts said region from said image and processes said region by removing features larger than expected marking sizes, binarising said region, removing features
10 smaller than expected marking sizes, removing features not clustered as identifying markings, and passing the remaining image for optical recognition if including more than a predetermined number of markings.

23. An image acquisition system as claimed in claim 17, wherein said moving object
15 is an aircraft.

24. An image acquisition system as claimed in claim 23, wherein said aircraft is in flight.

20 25. An object detection system as claimed in claim 2, including an image acquisition system as claimed in any one of claims 16 to 24, wherein said trigger signal is said image acquisition signal.

26. An object detection method including:
25 passively sensing electromagnetic radiation received from a moving object; generating intensity signals representative of the received radiation; and subtracting said intensity signals to obtain a differential signature representative of the position of said moving object.

30 27. An object detection method as claimed in claim 26, including generating an image acquisition signal on the basis of said differential signature.

- 36 -

28. An object detection method as claimed in claim 27, including acquiring an image of at least part of said moving object in response to said acquisition signal; and processing said image to identify said moving object.
- 5 29. An object detection method as claimed in claim 28, including processing said acquired image to extract markings identifying said moving object.
30. An object detection method as claimed in claim 26, 27, 28 or 29, wherein said moving object is an aircraft.
- 10 31. An object detection method as claimed in claim 30, wherein said aircraft is in flight.
32. An object detection method as claimed in claim 30, wherein said
15 electromagnetic radiation is thermal radiation.
33. An object detection method as claimed in claim 30, including detecting the presence of said aircraft within a predetermined region and, in response thereto, generating an activation signal to execute said passive sensing step.
- 20 34. An object detection method as claimed in claim 26, wherein said passive sensing includes imaging said radiation at successive periods of time, and said subtracting includes generating respective profiles of pixel values for images of said radiation and generating a difference profile, from the difference
25 between successive profiles, which includes said differential signature.
35. An object detection method as claimed in claim 34, wherein said position corresponds to a zero crossing point in said difference profile where said difference profile has risen above a first predetermined threshold for at least a first predetermined
30 distance and then falls to below a second predetermined threshold for a second predetermined distance.

- 37 -

36. An object detection method as claimed in claim 35, including monitoring the movement of said position in successive ones of said difference profile and determining the time for generation of an image acquisition signal.

5 37. An object detection method as claimed in claim 36, wherein said subtracting includes generating a background image from successive images of said radiation imaging means and subtracting said background image from images of said radiation before generating said profiles.

10 38. An object detection method as claimed in claim 26, wherein said passive sensing includes pyroelectric sensing with different fields of view and said intensity signals include at least first and second signals representative of the thermal radiation present in said views, respectively, and

15 said subtracting includes subtracting said first and second signals to obtain a differential signal including said differential signature.

39. An object detection method as claimed in claim 38, including determining a time for generation of an image acquisition signal on the basis of the position of passive sensors, the time of generation of said differential signature and the speed of said
20 moving object.

40. An object detection method as claimed in claim 39, wherein said time of generation and speed are determined from a zero crossing point of said differential signature.

25

41. An image acquisition method including:

acquiring an image of at least part of a moving object, in response to a trigger signal, using at least one camera, and

30 processing said image to locate a region in said image including markings identifying said object and processing said region to extract said markings for a recognition process.

- 38 -

42. An image acquisition method as claimed in claim 41, wherein said camera images received radiation between 0.69 to 2.0 μm .

43. An image acquisition method as claimed in claim 42, wherein said camera has
5 an exposure time of < 240 μs .

44. An image acquisition method as claimed in claim 42, including adjusting the power of an infrared flash for said camera on the basis of the aperture setting of said camera.

10

45. An image acquisition method as claimed in claim 42, including obtaining automatic measurements of ambient direct light and reflected light for the field of view of said camera and adjusting settings of said camera on the basis of said measurements.

15

46. An image acquisition method as claimed in claim 41, wherein said image processing includes sub-sampling said image, extracting lines exceeding a predetermined length and at predetermined angles, binarising the image, removing features smaller or larger than said markings, removing features not clustered as said
20 markings, and locating said region using the remaining features.

47. An image acquisition method as claimed in claim 46, wherein said region processing includes extracting said region from said image, removing features larger than expected marking sizes, binarising said region, removing features with areas
25 smaller or larger than expected marking areas, removing features not clustered as identifying markings, and passing the remaining image for optical recognition if including more than a predetermined number of markings.

48. An image acquisition method as claimed in claim 42, wherein said moving
30 object is an aircraft.

- 39 -

49. An image acquisition method as claimed in claim 48, wherein said aircraft is in flight.

50. An object detection method as claimed in claim 27, including an image acquisition method as claimed in any one of claims 41 to 49, wherein said trigger signal is said image acquisition signal.

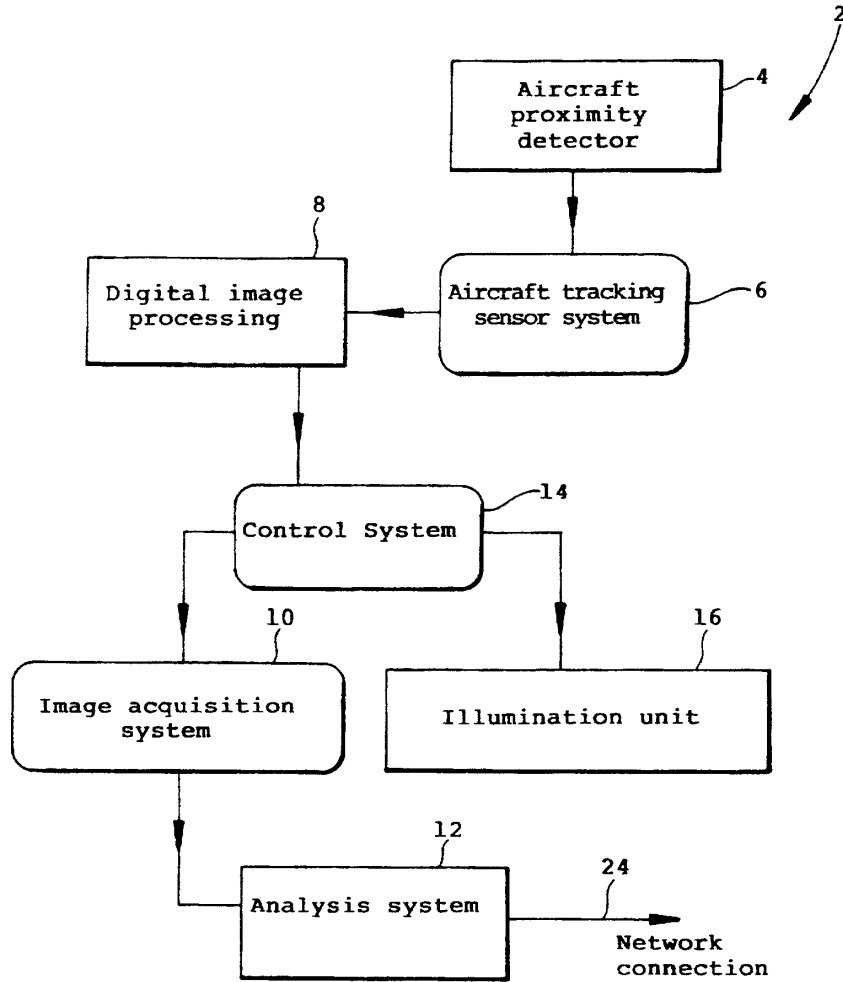

FIGURE 1

SUBSTITUTE SHEET (RULE 26)

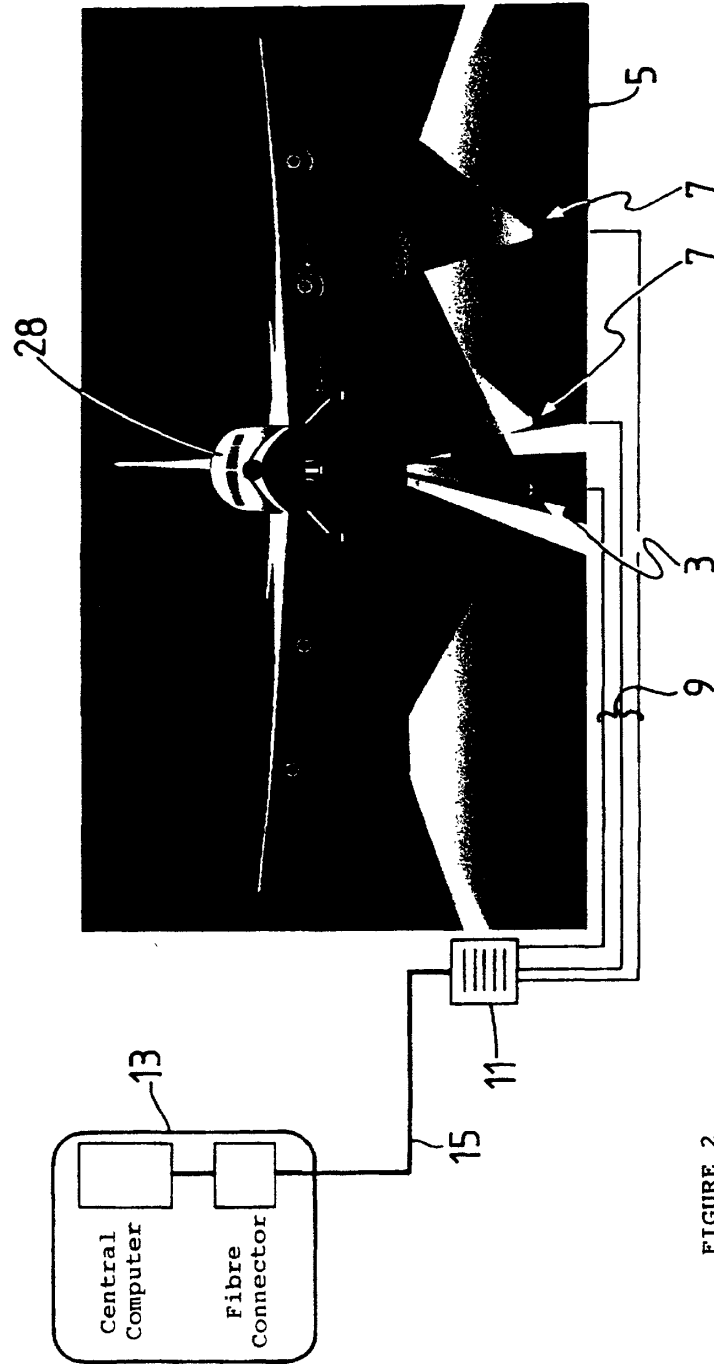
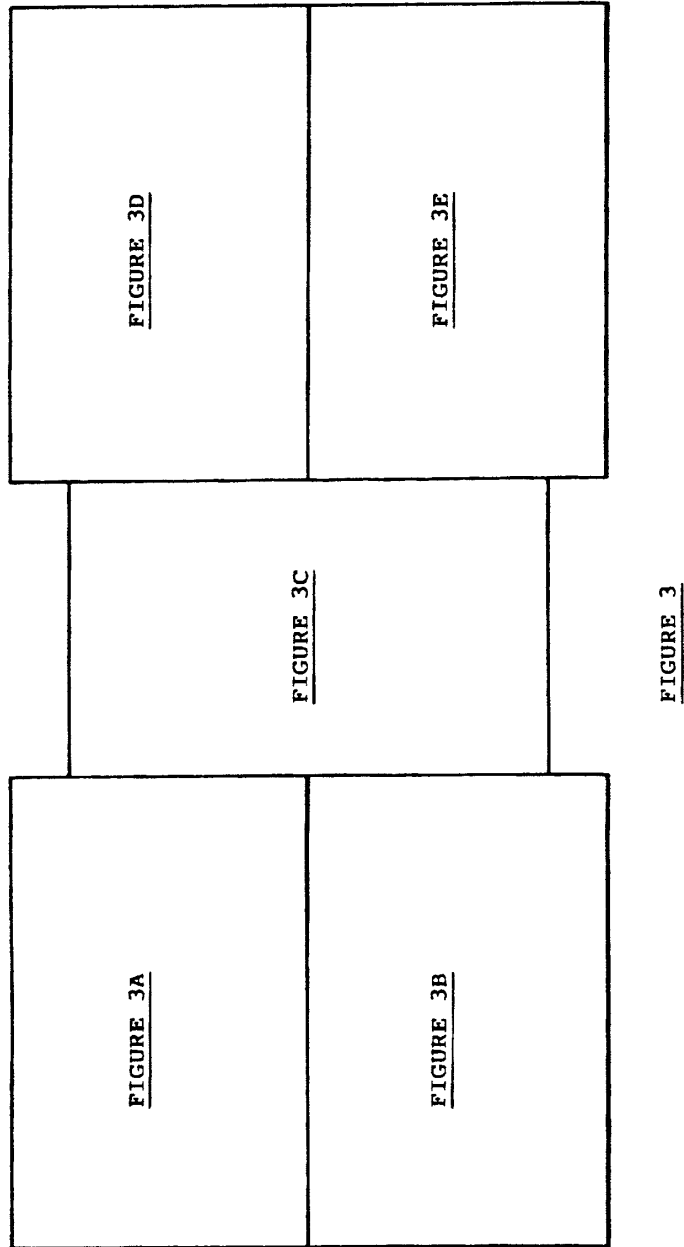

FIGURE 2

SUBSTITUTE SHEET (RULE 26)



SUBSTITUTE SHEET (RULE 26)

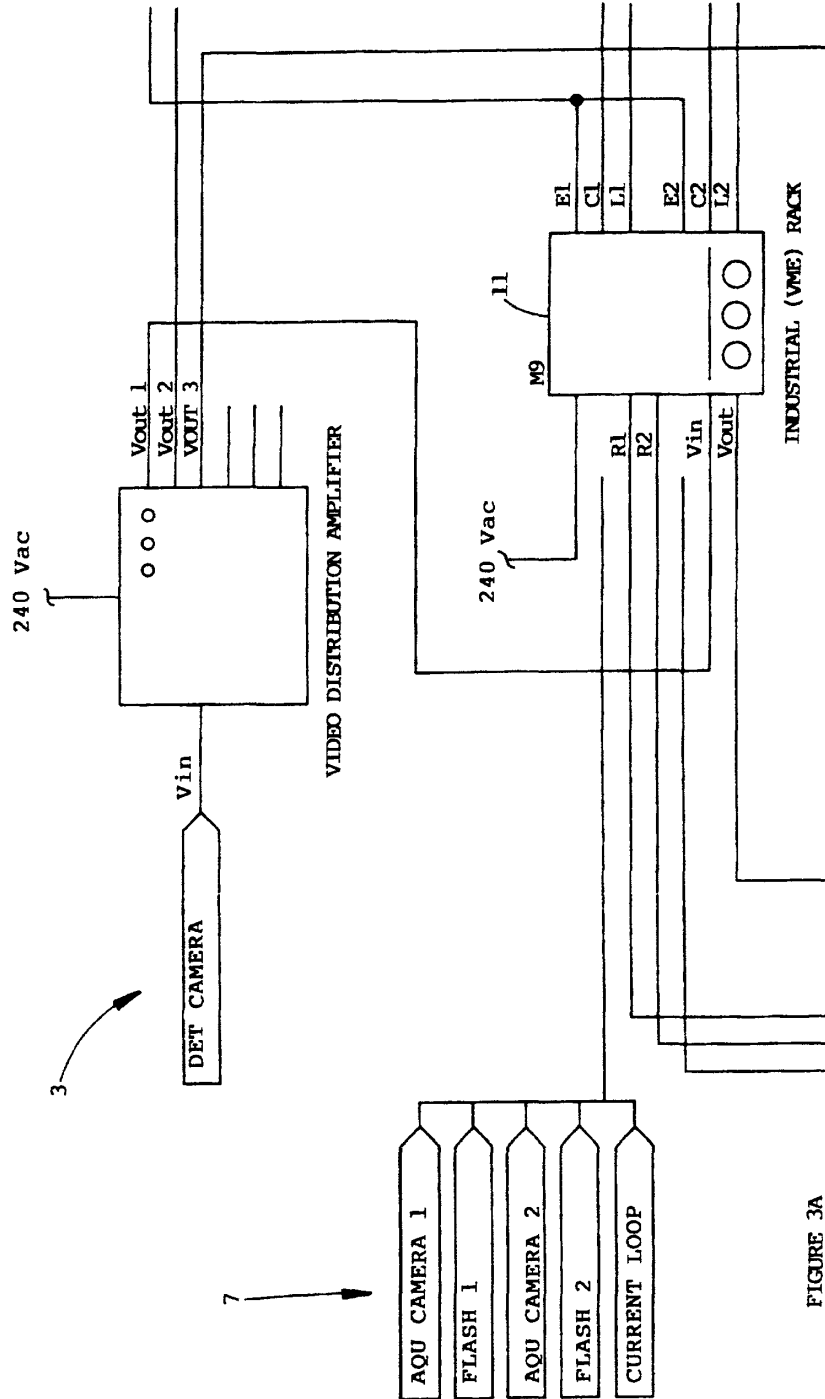

FIGURE 3A

SUBSTITUTE SHEET (RULE 26)

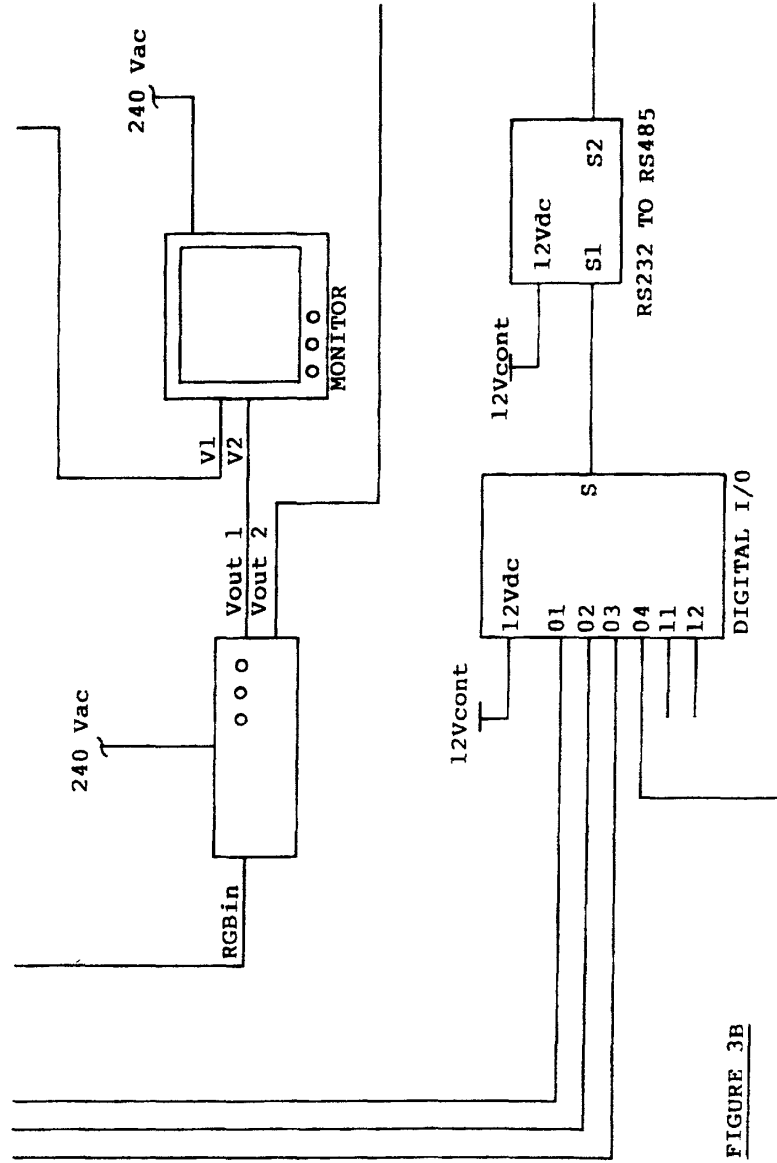
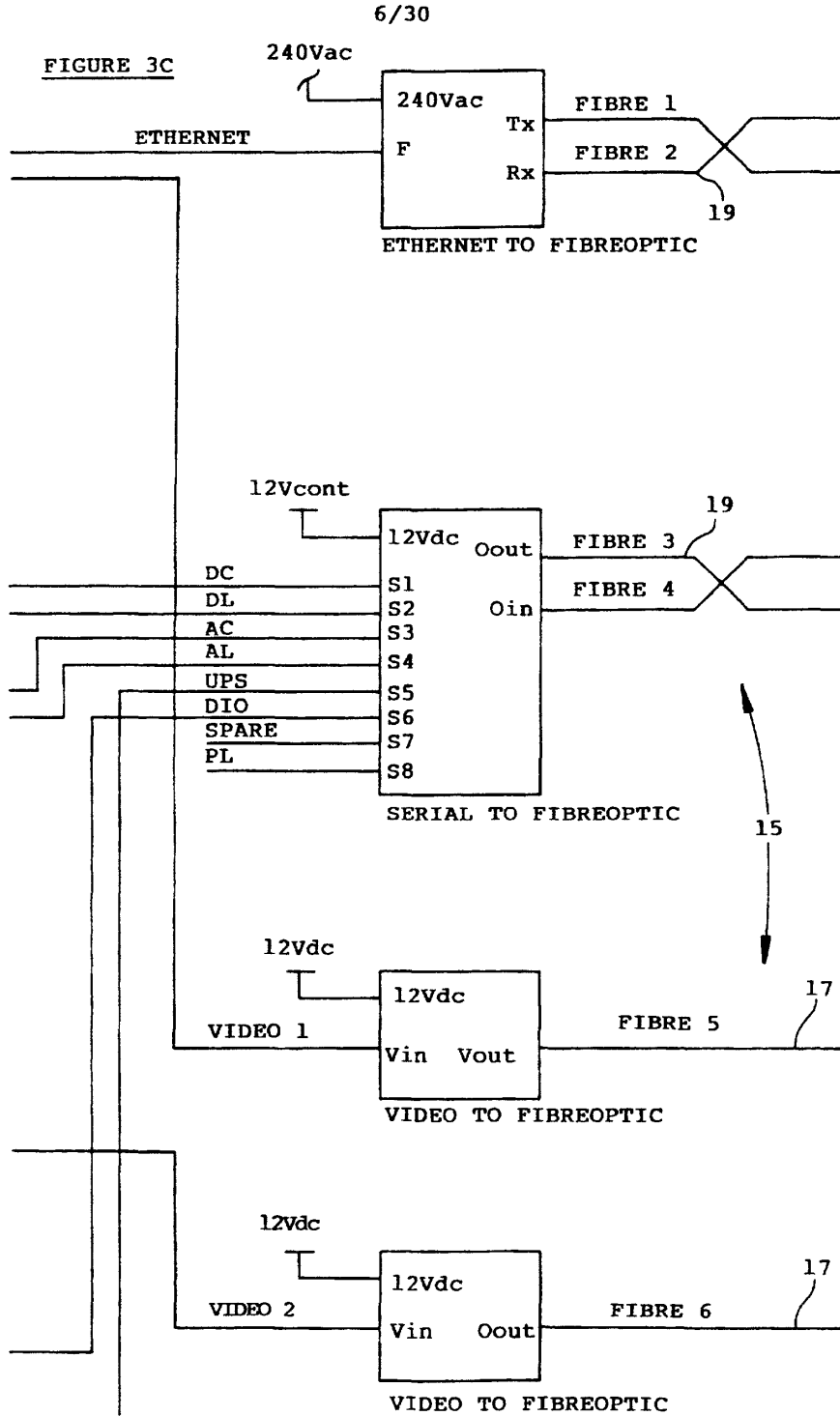

FIGURE 3B

SUBSTITUTE SHEET (RULE 26)



SUBSTITUTE SHEET (RULE 26)

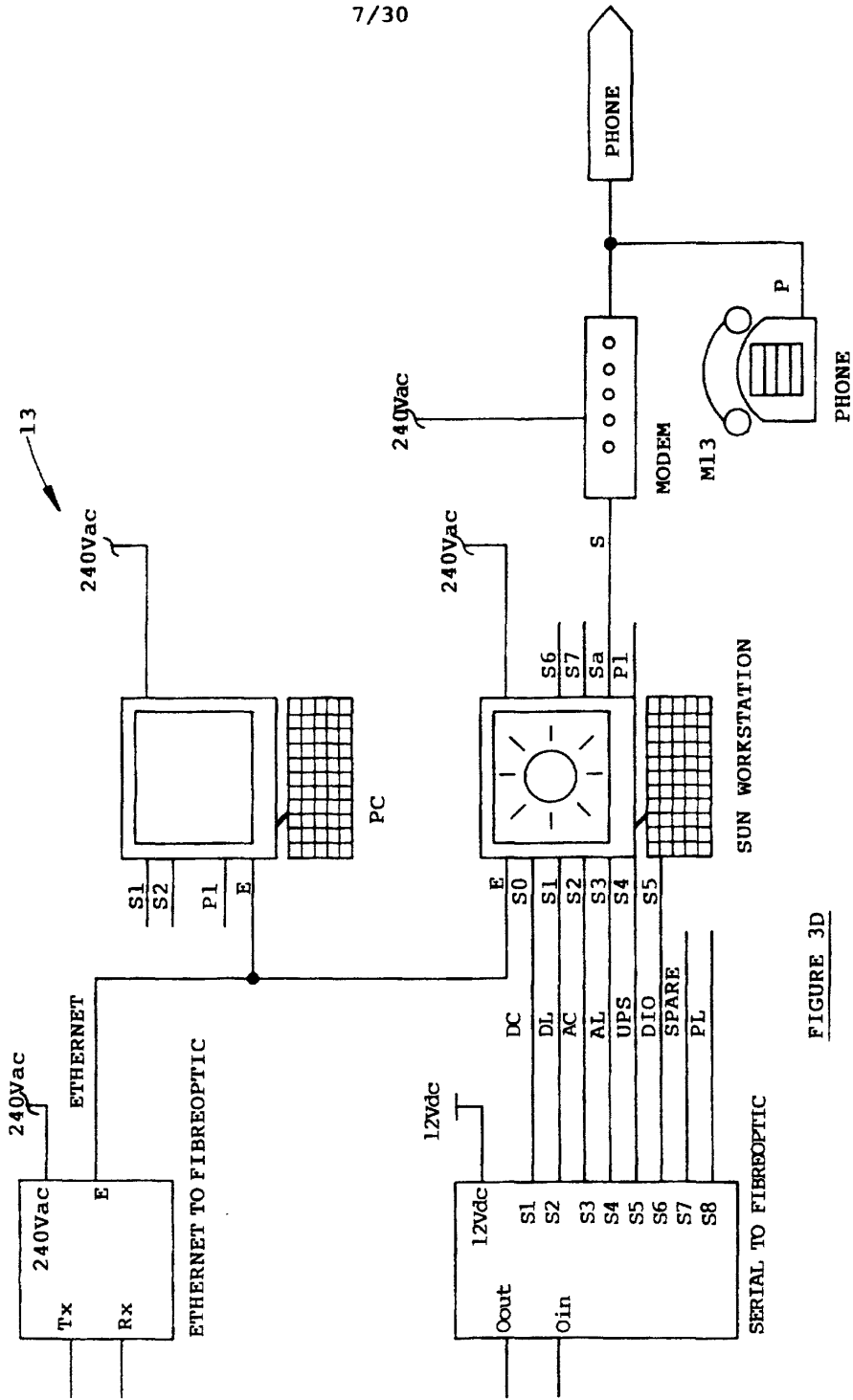

FIGURE 3D

SUBSTITUTE SHEET (RULE 26)

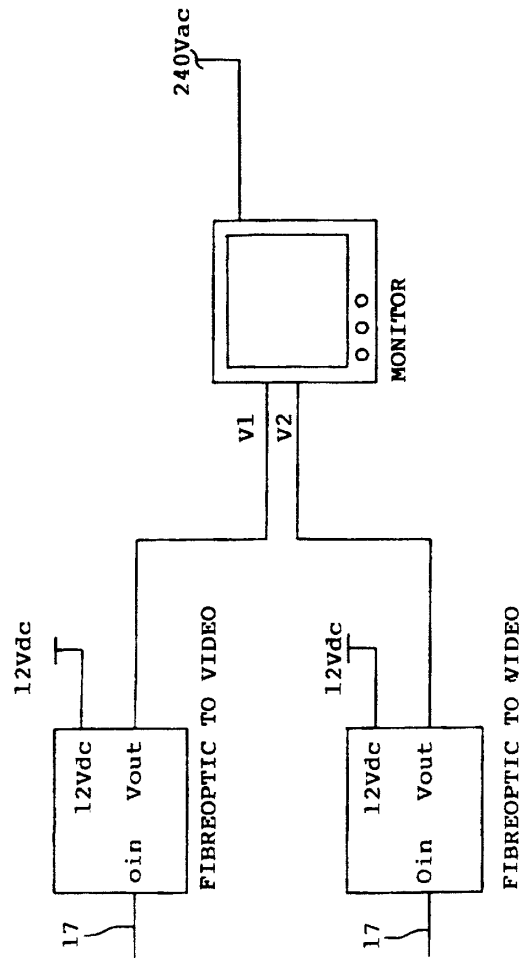

FIGURE 3E

SUBSTITUTE SHEET (RULE 26)

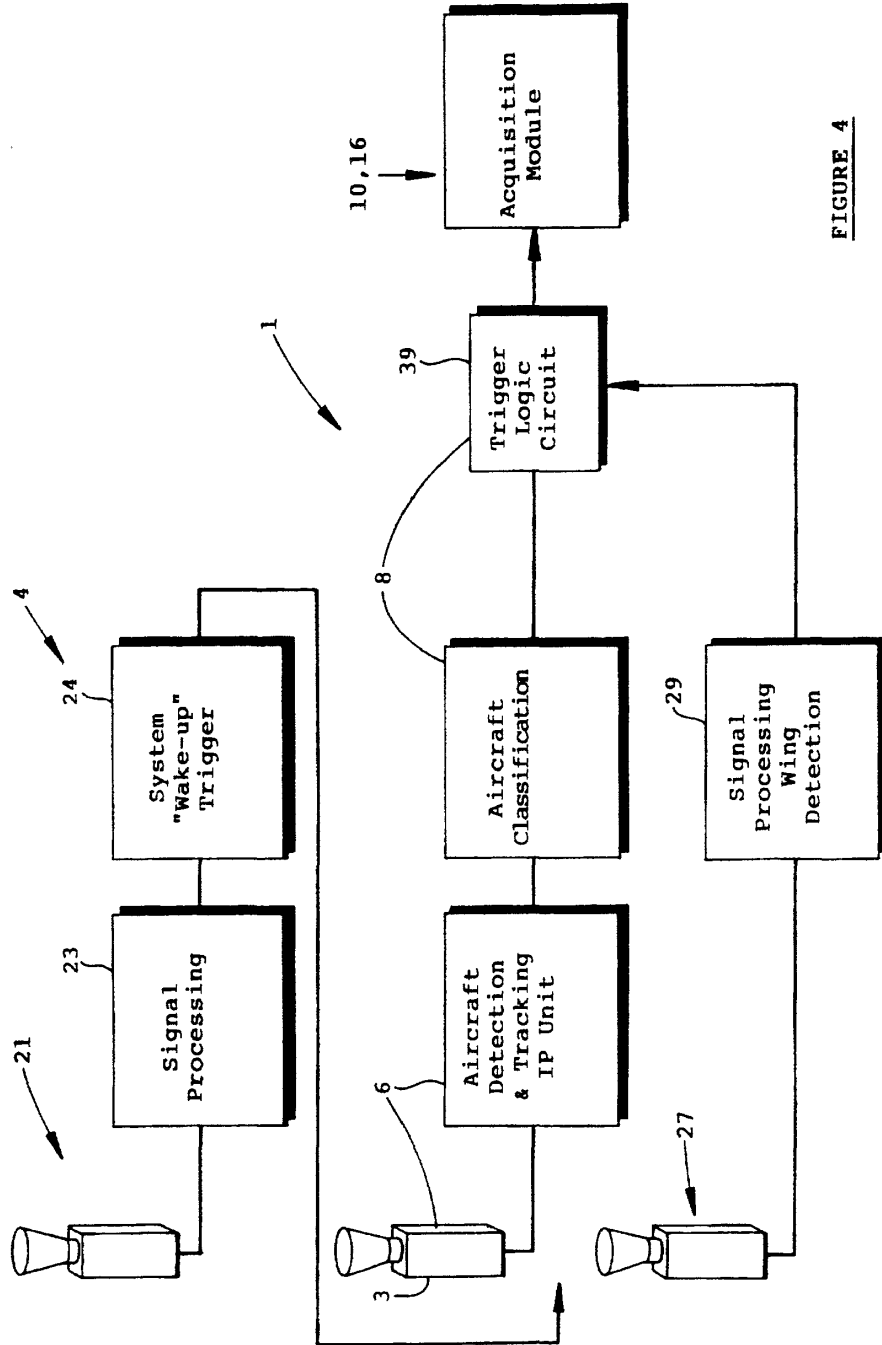

FIGURE 4

SUBSTITUTE SHEET (RULE 26)

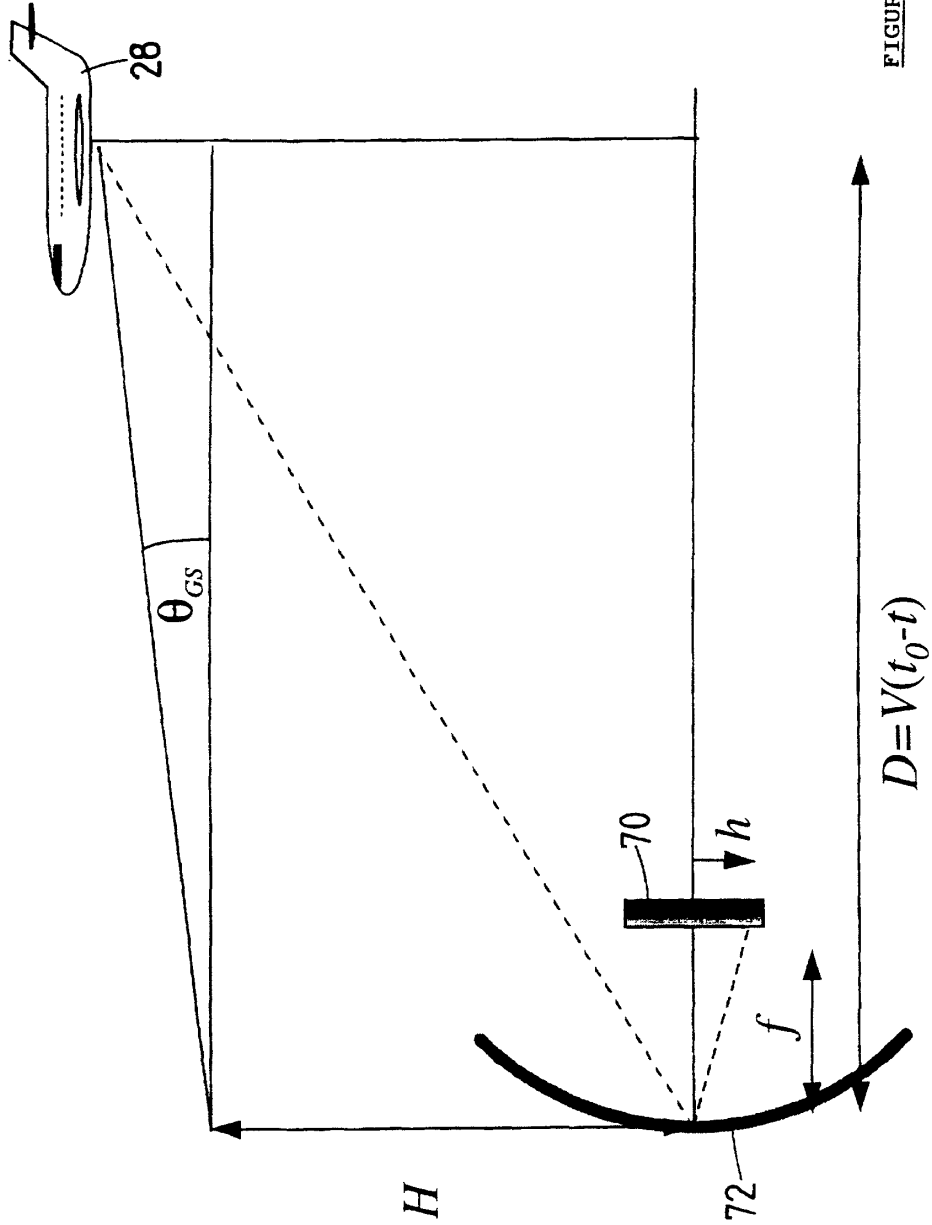

FIGURE 5

SUBSTITUTE SHEET (RULE 26)

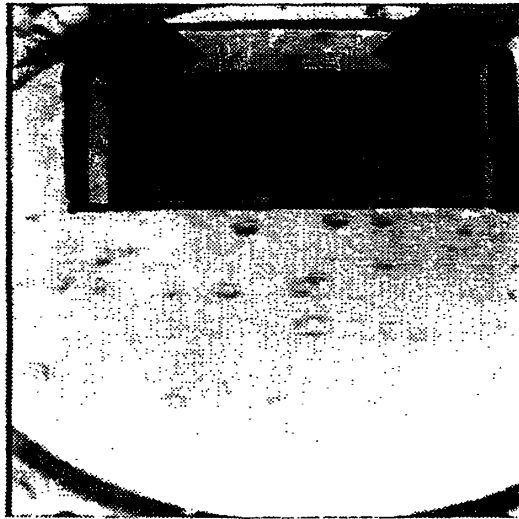

Figure 6a

SUBSTITUTE SHEET (RULE 26)

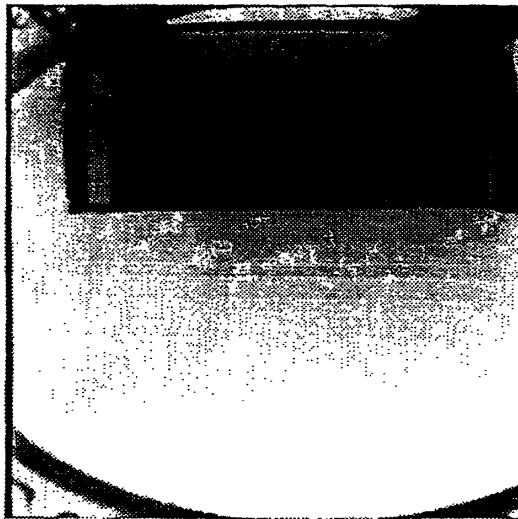

Figure 6b

SUBSTITUTE SHEET (RULE 26)

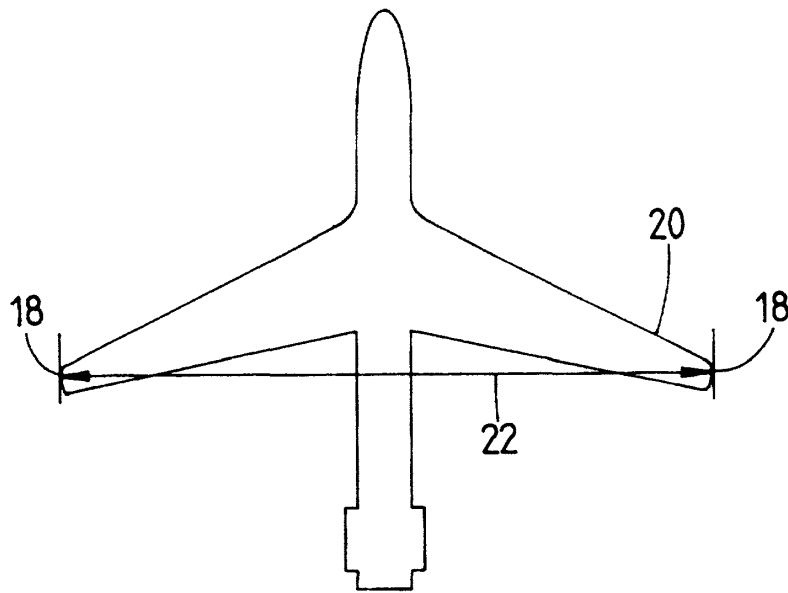

FIGURE 7

SUBSTITUTE SHEET (RULE 26)

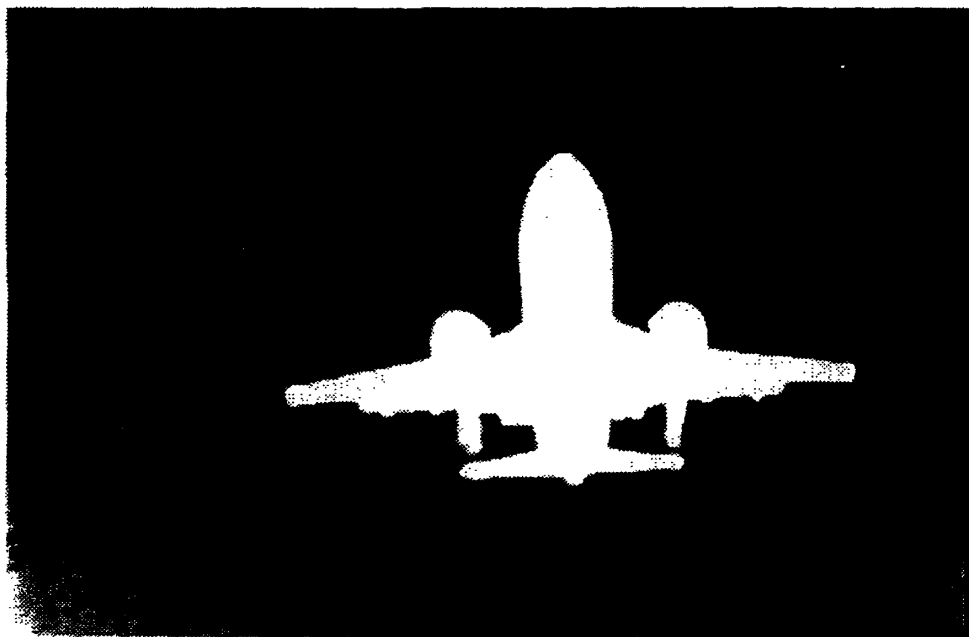

Figure 8

SUBSTITUTE SHEET (RULE 26)



Figure 9

SUBSTITUTE SHEET (RULE 26)

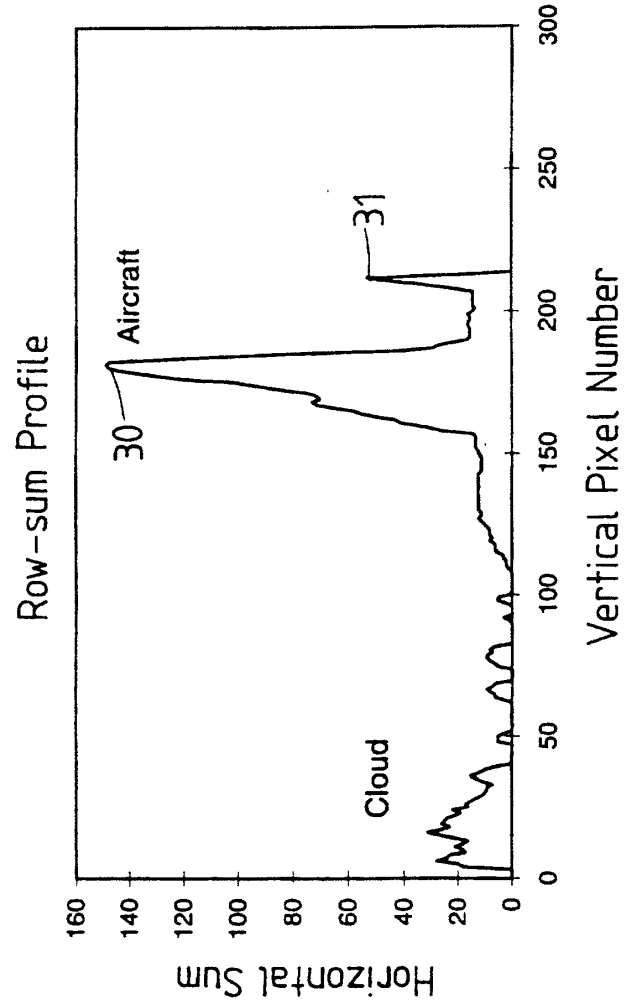

FIGURE 10

SUBSTITUTE SHEET (RULE 26)

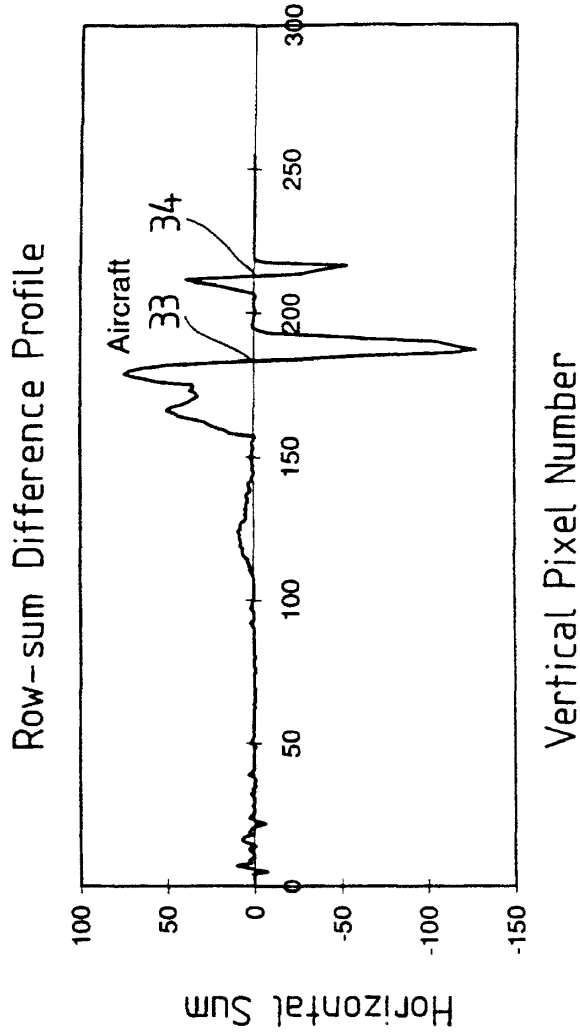

FIGURE 11

SUBSTITUTE SHEET (RULE 26)

(x, y, z)

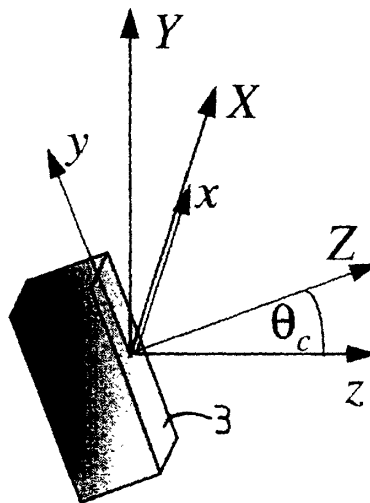

FIGURE 12

SUBSTITUTE SHEET (RULE 26)

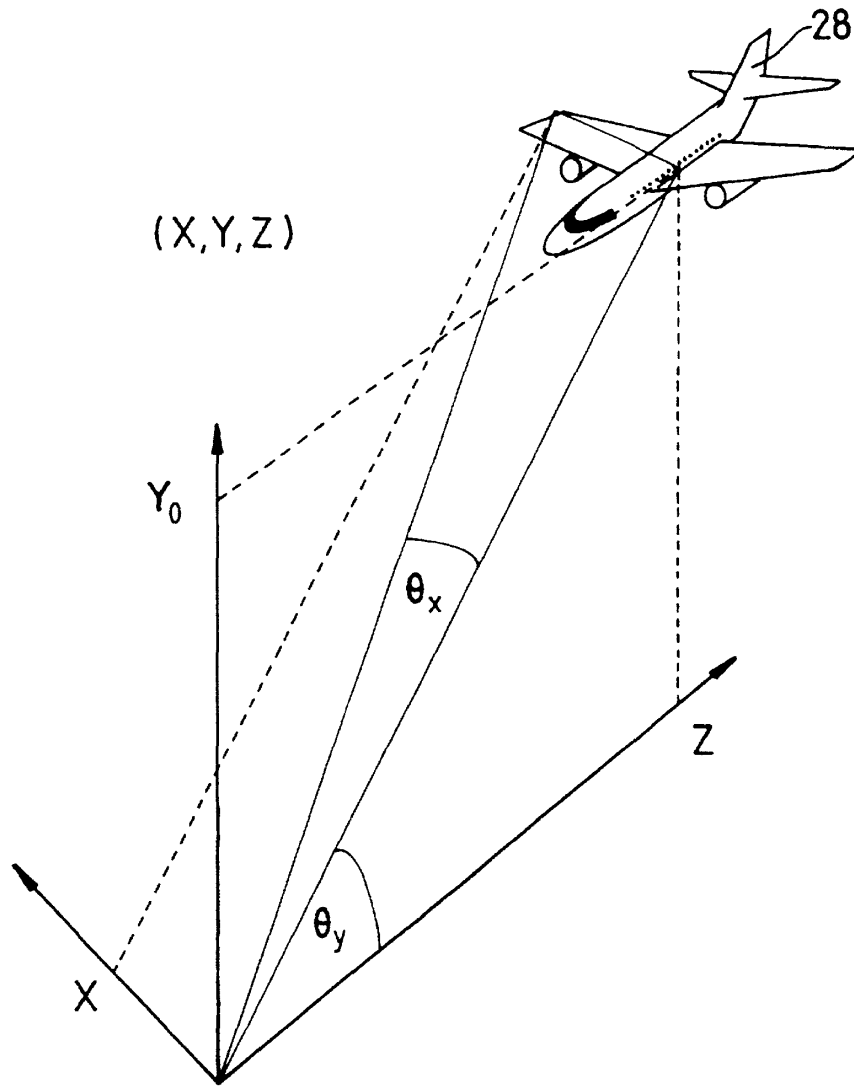

FIGURE 13

SUBSTITUTE SHEET (RULE 26)

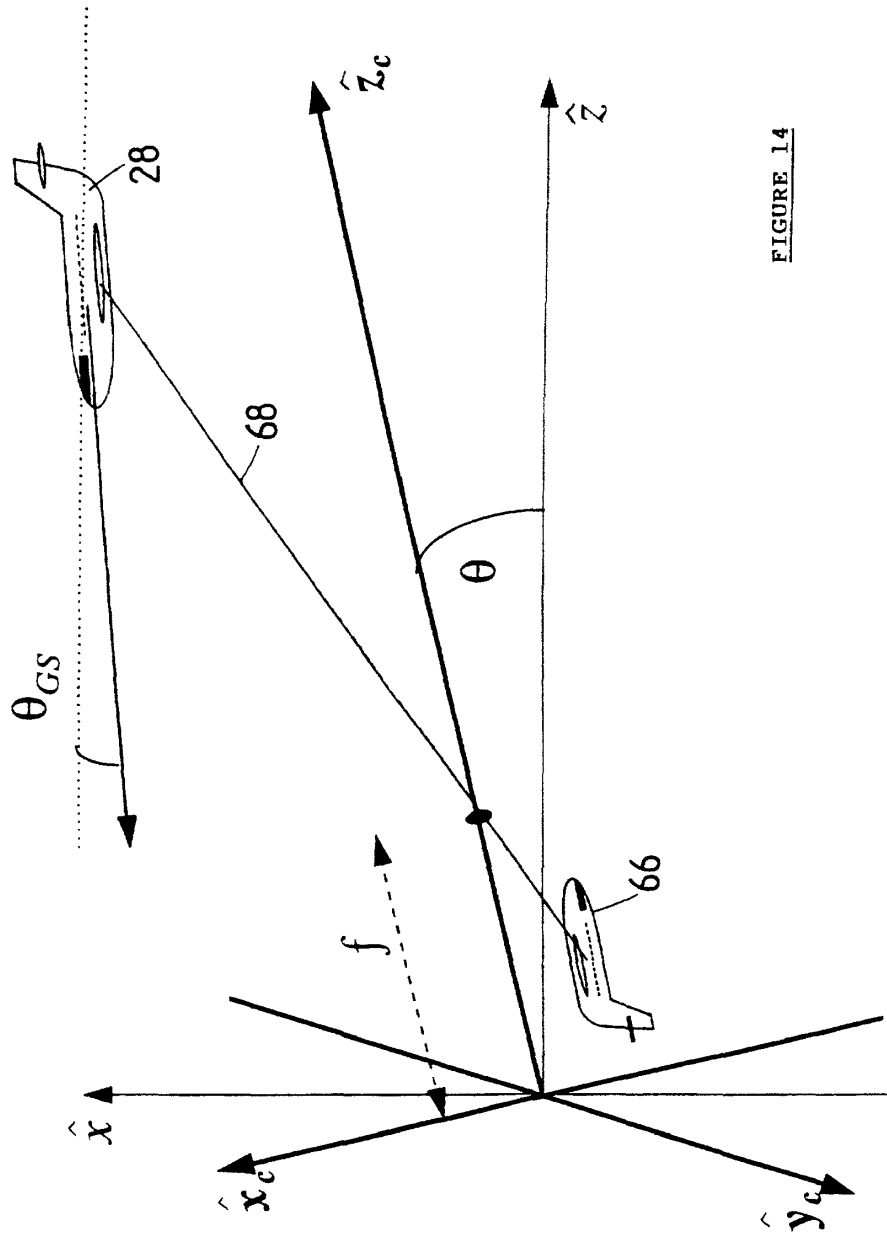

FIGURE 14

SUBSTITUTE SHEET (RULE 26)

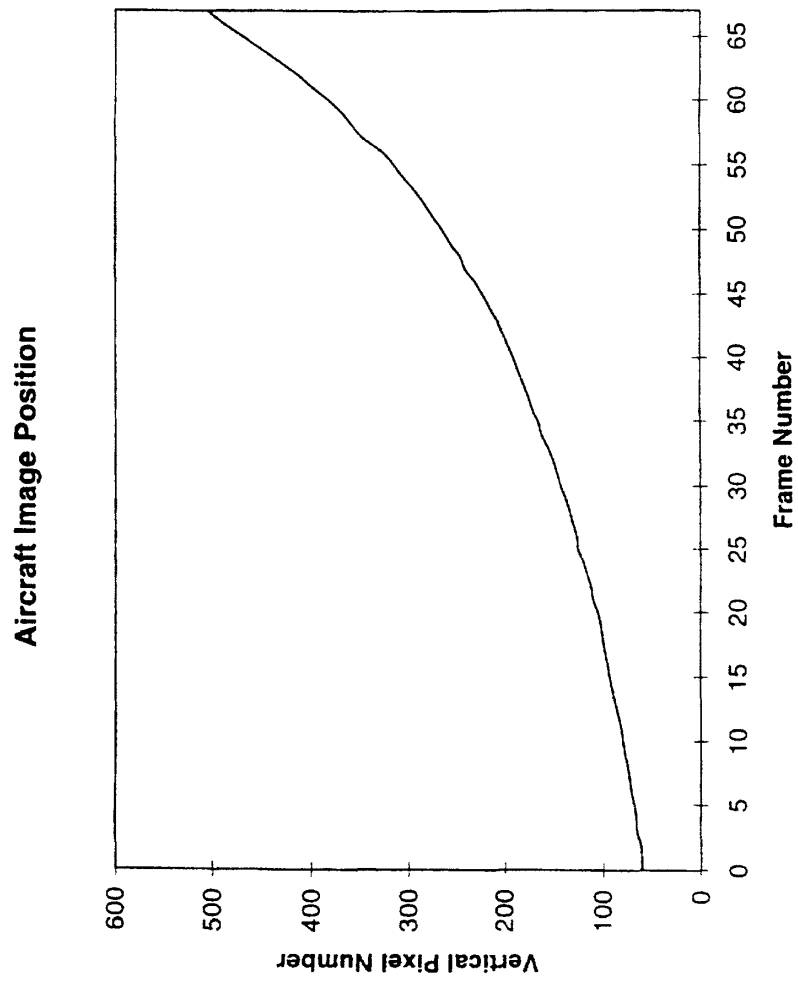

FIGURE 15

SUBSTITUTE SHEET (RULE 26)

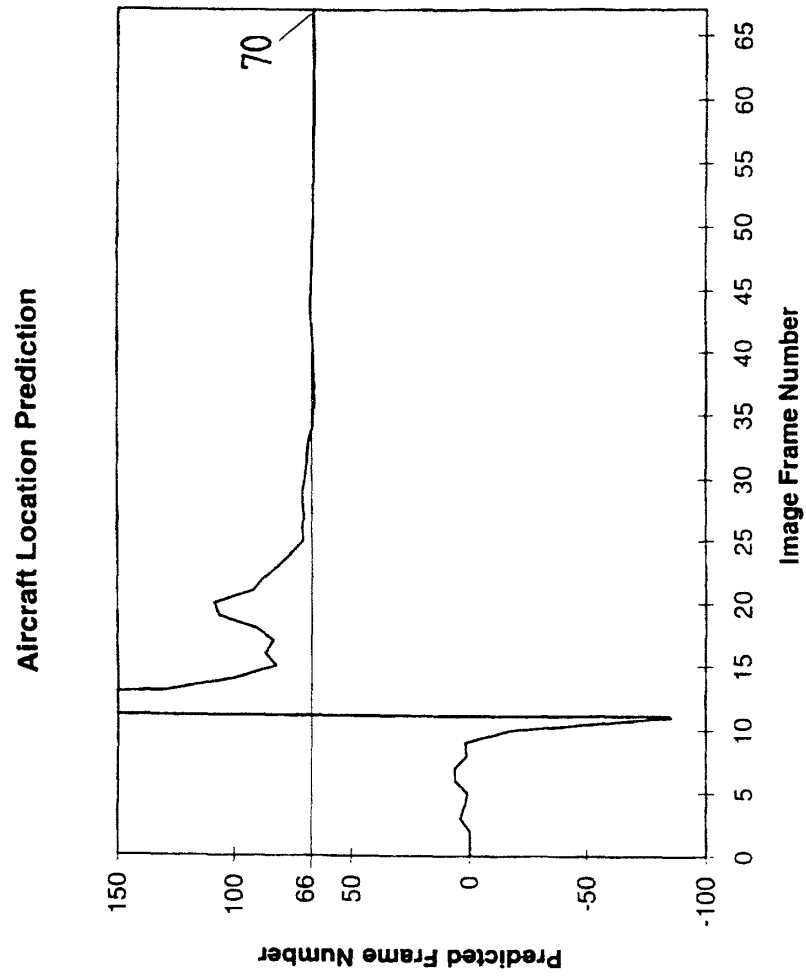

FIGURE 16

SUBSTITUTE SHEET (RULE 26)

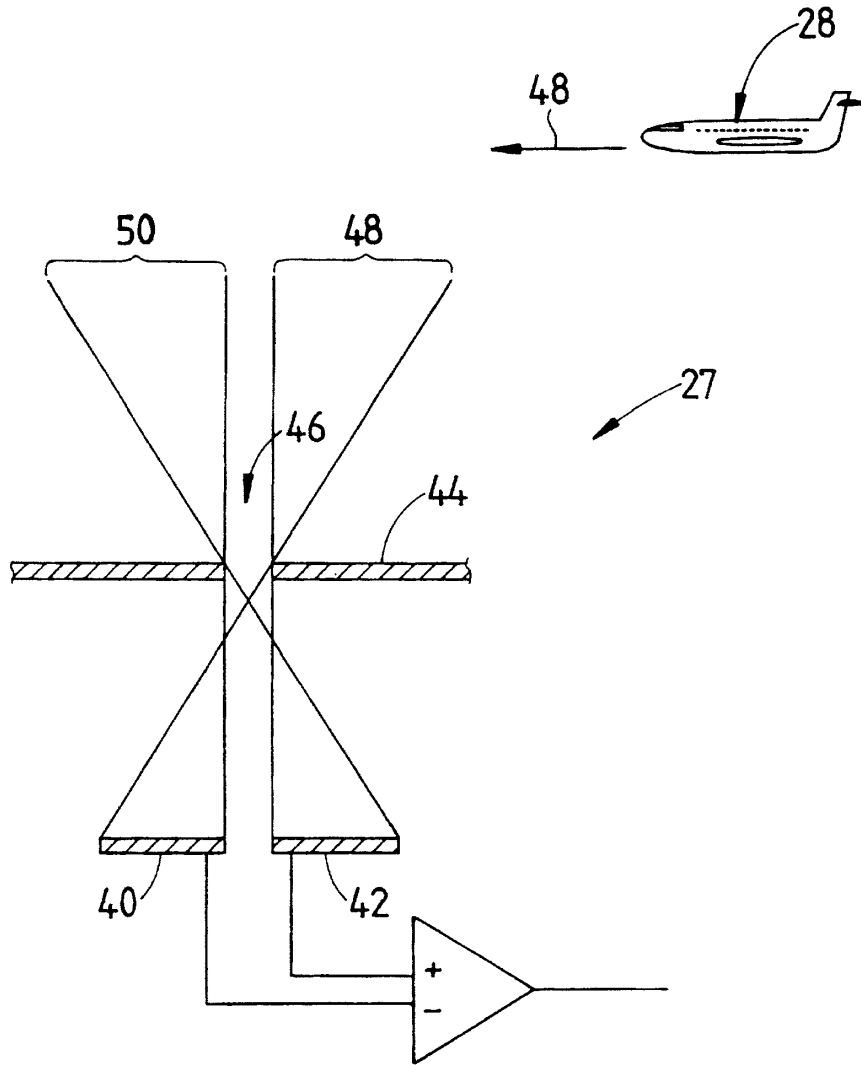

FIGURE 17

SUBSTITUTE SHEET (RULE 26)

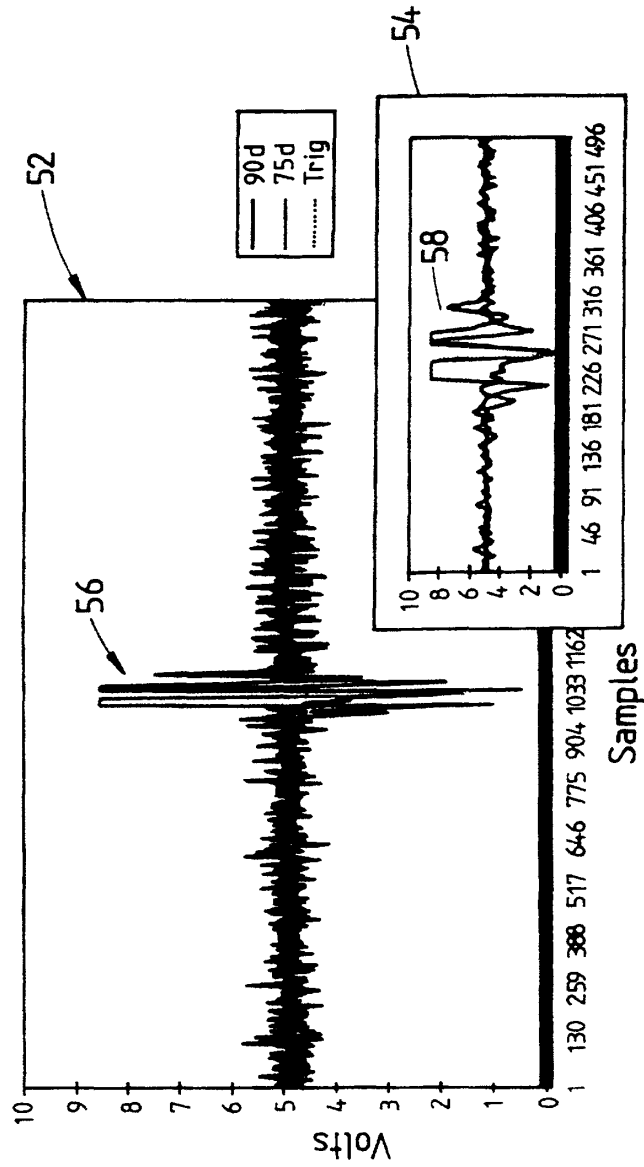

FIGURE 18

SUBSTITUTE SHEET (RULE 26)

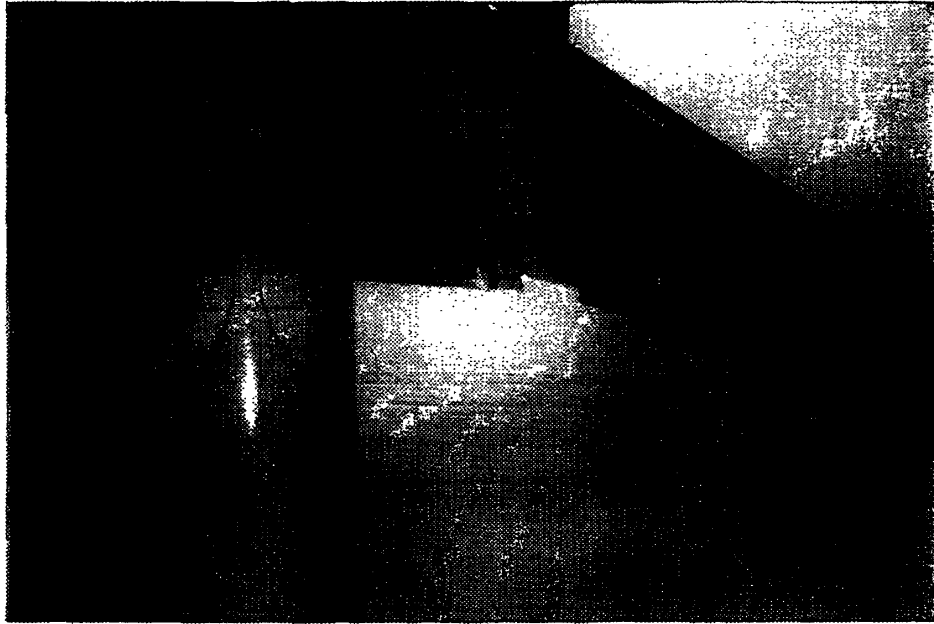

Figure 19

SUBSTITUTE SHEET (RULE 26)

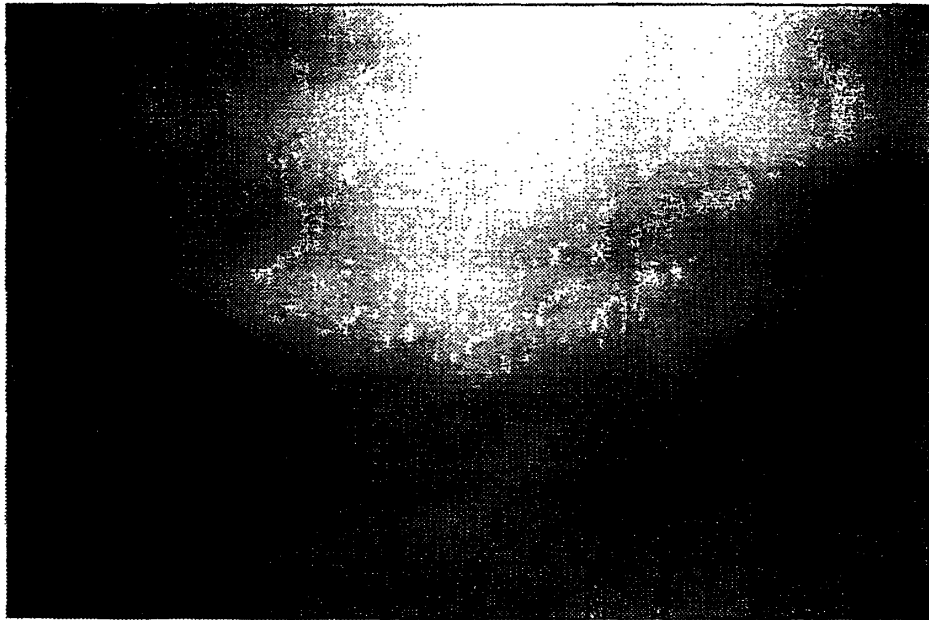

Figure 20

SUBSTITUTE SHEET (RULE 26)

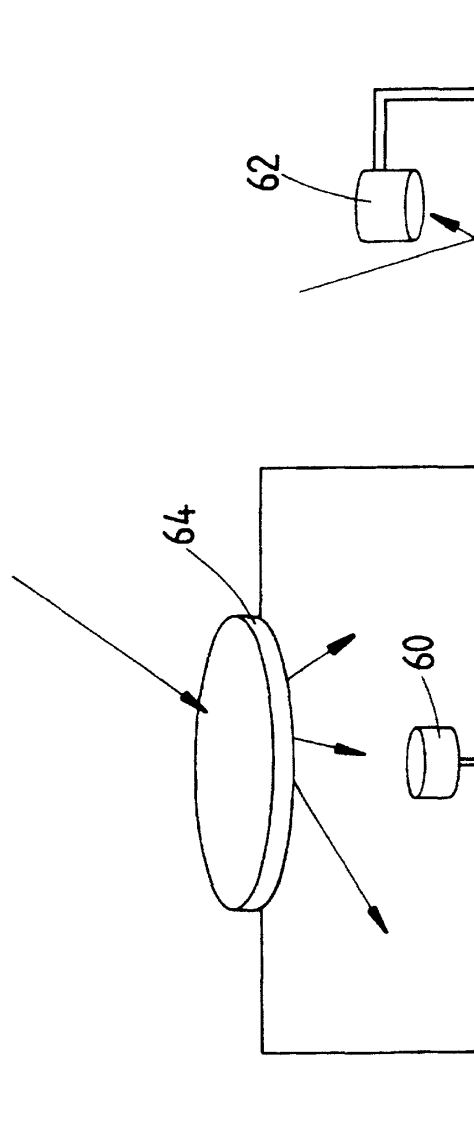

FIGURE 21

SUBSTITUTE SHEET (RULE 26)

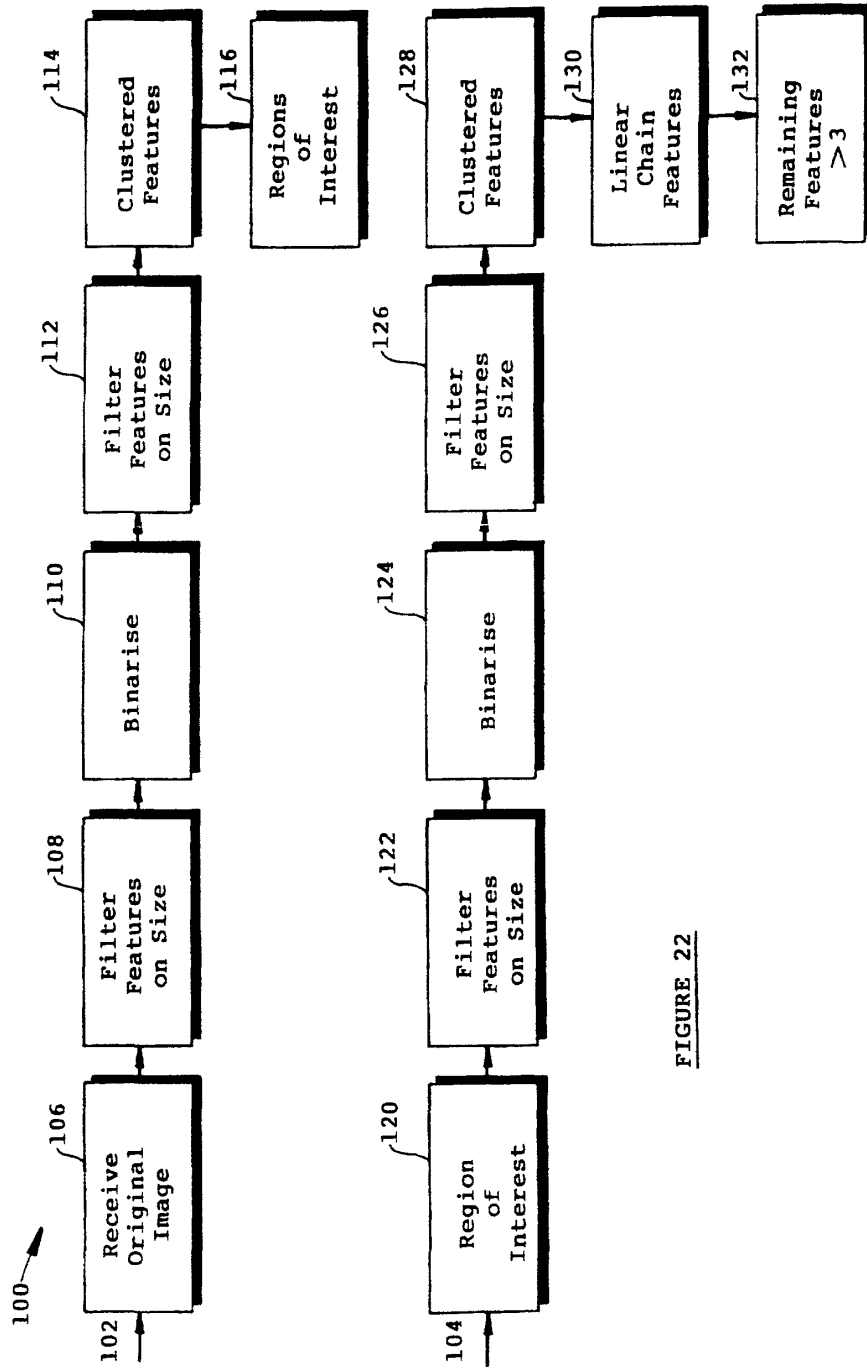
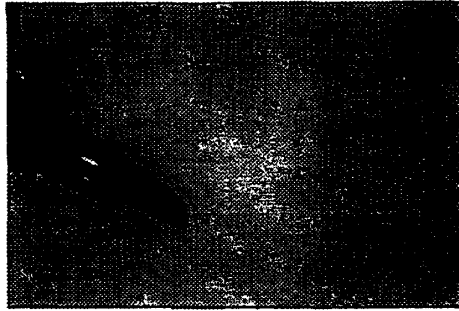
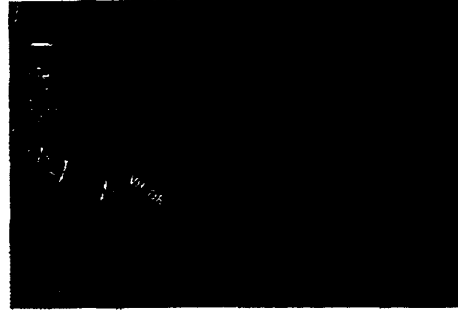

FIGURE 22



105



109



111

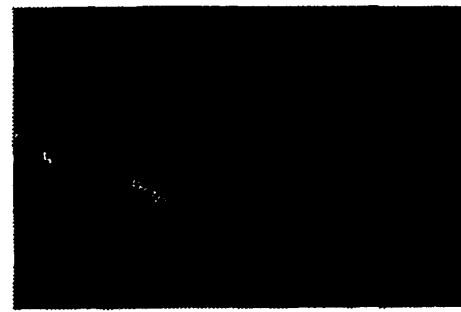

113



115

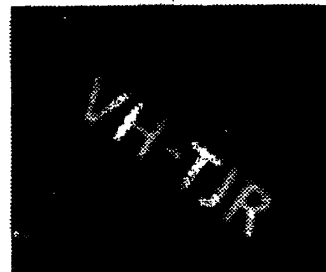

117



118



Figure 23

SUBSTITUTE SHEET (RULE 26)

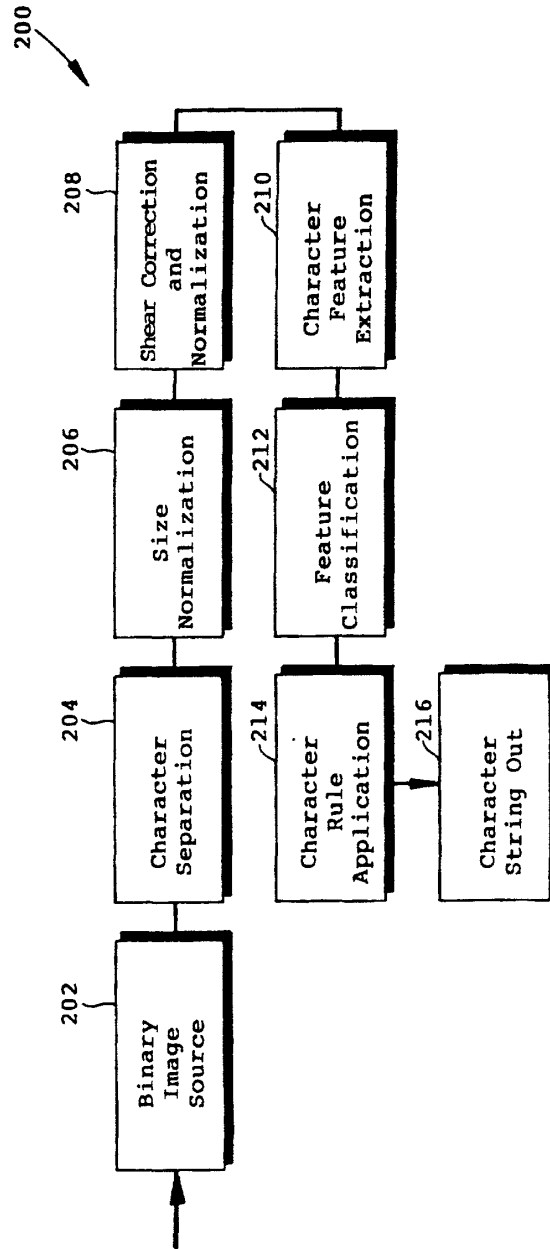

FIGURE 24

SUBSTITUTE SHEET (RULE 26)

INTERNATIONAL SEARCH REPORT

International Application No.
PCT/AU 97/00198

A. CLASSIFICATION OF SUBJECT MATTER		
Int Cl ⁶ : G08G 5/00, G01P 3/38, G06T 7/20, G06K 9/78, 9/46		
According to International Patent Classification (IPC) or to both national classification and IPC		
B. FIELDS SEARCHED		
Minimum documentation searched (classification system followed by classification symbols) IPC as above		
Documentation searched other than minimum documentation to the extent that such documents are included in the fields searched AU: IPC as above		
Electronic data base consulted during the international search (name of data base and, where practicable, search terms used) WPAT, INSC (IMAG.; OBJECT.; DETECT.; POSITION.; MARK, ID:)		
C. DOCUMENTS CONSIDERED TO BE RELEVANT		
Category*	Citation of document, with indication, where appropriate, of the relevant passages	Relevant to claim No.
X	EP 686943- A2 (Matsushita Electric Industrial Co. Ltd.) 13 December 1995, whole document	1, 26, 9, 34
X	US 5,406,501 (U.S. Philips Corp.) 11 April 1995, whole document	1, 7, 9, 32, 34
X	WO 93/19441 (Commonwealth Scientific and Industrial Research Organisation) 30 September 1993 whole document	1-4, 16, 17, 19, 20 26-29, 41, 42, 44, 45
<input checked="" type="checkbox"/> Further documents are listed in the continuation of Box C <input checked="" type="checkbox"/> See patent family annex		
<p>* Special categories of cited documents:</p> <p>"A" document defining the general state of the art which is not considered to be of particular relevance</p> <p>"E" earlier document but published on or after the international filing date</p> <p>"L" document which may throw doubts on priority claim(s) or which is cited to establish the publication date of another citation or other special reason (as specified)</p> <p>"O" document referring to an oral disclosure, use, exhibition or other means</p> <p>"P" document published prior to the international filing date but later than the priority date claimed</p> <p>"T" later document published after the international filing date or priority date and not in conflict with the application but cited to understand the principle or theory underlying the invention</p> <p>"X" document of particular relevance; the claimed invention cannot be considered novel or cannot be considered to involve an inventive step when the document is taken alone</p> <p>"Y" document of particular relevance; the claimed invention cannot be considered to involve an inventive step when the document is combined with one or more other such documents, such combination being obvious to a person skilled in the art</p> <p>"&" document member of the same patent family</p>		
Date of the actual completion of the international search 9 May 1997		Date of mailing of the international search report 21 MAY 1997
Name and mailing address of the ISA/AU AUSTRALIAN INDUSTRIAL PROPERTY ORGANISATION PO BOX 200 WODEN ACT 2606 AUSTRALIA Facsimile No. (06) 285 3929		Authorized officer Dale Siver Telephone No.: (06) 283 2196

INTERNATIONAL SEARCH REPORT

International Application No.

PCT/AU 97/00198

C (Continuation) DOCUMENTS CONSIDERED TO BE RELEVANT		
Category*	Citation of document, with indication, where appropriate, of the relevant passages	Relevant to claim No
X Y	US 5,243,418 (K.K. Toshiba, Kawasaki) 7 September 1993, whole document	1, 26, 9, 34 10, 35
X Y	AU-35311/93-B (Iconix Pty Ltd) 8 July 1993, whole document especially page 21, lines 11-26	16, 41 21, 46
X	US 5, 134, 472 (K.K. Toshiba) 28 July 1992, whole document	1, 9, 26, 34
X Y	GB 2,227,589 A (Image Recognition Equipment Corp.) 1 August 1990 Abstract, Summary pages 1-4, Figures	16, 41 21, 46
X	WO 90/01706 (Hughes Aircraft Co.) 22 February 1990, whole document	1, 5, 6, 9, 10, 26, 30, 31, 34, 35
Y	WO 93/21617 (Traffic Technology Ltd.) 28 October 1993, whole document	1, 2, 26, 27
A	WO 96/12265 (Airport Technology in Scandinavia) 25 April 1996, Abstract Figures	5, 23, 26, 48

Box I Observations where certain claims were found unsearchable (Continuation of item 1 of first sheet)

This International Search Report has not been established in respect of certain claims under Article 17(2)(a) for the following reasons:

1. Claims Nos. .
because they relate to subject matter not required to be searched by this Authority, namely:

2. Claims Nos.:
because they relate to parts of the international application that do not comply with the prescribed requirements to such an extent that no meaningful international search can be carried out, specifically:

3. Claims Nos.:
because they are dependent claims and are not drafted in accordance with the second and third sentences of Rule 6 4(a)

Box II Observations where unity of invention is lacking (Continuation of item 2 of first sheet)

This International Searching Authority found multiple inventions in this international application, as follows:

1. An object detection system using passive sensor to obtain a differential signature representative of the position of moving object. (No image acquisition or analysis) Claims 1, 5-10, 26, 34, 35, 38.
2. An image acquisition system and analysis system to locate a region in an image including markings identifying said object and processing said region to extract said markings for recognition. (No position or movement detection.) Claims 16-22, 41-47.
1. As all required additional search fees were timely paid by the applicant, this international search report covers all searchable claims
2. As all searchable claims could be searched without effort justifying an additional fee, this Authority did not invite payment of any additional fee.
3. As only some of the required additional search fees were timely paid by the applicant, this international search report covers only those claims for which fees were paid, specifically claims Nos.:

4. No required additional search fees were timely paid by the applicant. Consequently, this international search report is restricted to the invention first mentioned in the claims; it is covered by claims Nos.:

Remark on Protest The additional search fees were accompanied by the applicant's protest.
 No protest accompanied the payment of additional search fees.

INTERNATIONAL SEARCH REPORT
Information on patent family members

International Application No.
PCT/AU 97/00198

This Annex lists the known "A" publication level patent family members relating to the patent documents cited in the above-mentioned international search report. The Australian Patent Office is in no way liable for these particulars which are merely given for the purpose of information.

Patent Document Cited in Search Report				Patent Family Member			
EP	686943	CA	2151079	JP	7336694	US	5606376
US	5406501	EP	492724	FR	2670978	JP	4307681
WO	9319441	AU	37402/93	EP	631683	JP	7505966
		NZ	249799				
US	5243418	JP	4192781	JP	5046771		
AU	35311/93	AU	37398/93	WO	9319429		
US	5134472	JP	2207381	JP	2214989		
GB	2227589	FR	2642542	JP	2282881	US	4958064
WO	9001706	AU	44005/89	CA	1313704	DE	68910498
		EP	380658	ES	2016049	IL	90898
		JP	3502018	NO	901560	TR	25266
		US	4937878				
WO	9321617	AU	39599/93	GB	2266398		
WO	9612265	AU	11251/95				

END OF ANNEX

12

EUROPEAN PATENT APPLICATION

21 Application number: 87300392.5

51 Int. Cl. 4: **G 08 B 13/18**

22 Date of filing: 16.01.87

30 Priority: 03.02.86 GB 8602575

43 Date of publication of application:
12.08.87 Bulletin 87/33

84 Designated Contracting States:
AT BE CH DE ES FR GR IT LI LU NL SE

71 Applicant: **SAYZEN LIMITED**
53 Brookwood Road
Southfields London SW18 5BQ (GB)

72 Inventor: **Hale, Christopher John**
53 Brookwood Road
Southfields London, SW18 5BQ (GB)

74 Representative: **Jones, Graham H.**
Graham Jones & Company 77 Beaconsfield Road
Blackheath
London SE3 7LG (GB)

54 **An aircraft surveillance system.**

57 An aircraft surveillance system (2) comprising an aircraft (4), at least one closed circuit slow scan television camera (6) which is positioned in the aircraft (4) and which is for surveying a predetermined area, first transducer means (8) which is positioned in the aircraft (4) and which is for converting video signals from the camera (6) into audio signals, first transceiver means (10) which is positioned in the aircraft (4) and which is for transmitting the audio signals from the first transducer means (8) and for receiving command signals, second transceiver means (12) which is positioned in a command base (14) remote from the aircraft (4) and which is for receiving the audio signals from the first transceiver means (10) and for sending the command signals, second transducer means (16) which is positioned in the command base (14) and which is for converting the audio signals received from the second transceiver means (12) into video signals, and at least one television monitor (18) for providing a visual display consequent upon receiving the video signals from the second transducer means (16).

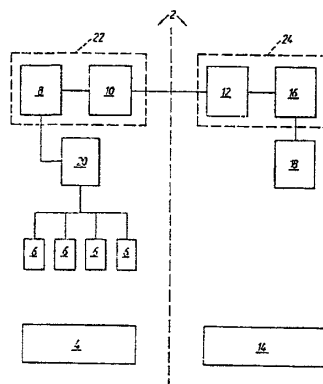

EP 0 232 031 A2

Description

AN AIRCRAFT SURVEILLANCE SYSTEM

This invention relates to an aircraft surveillance system.

It is an aim of the present invention to provide an aircraft surveillance system which can be used to survey the inside of an aircraft during an emergency such for example as a hijack or which can be used to survey land or objects outside the aircraft such for example as a border sheltering terrorists.

Accordingly, this invention provides an aircraft surveillance system comprising an aircraft, at least one closed circuit slow scan television camera which is positioned in the aircraft and which is for surveying a predetermined area, first transducer means which is positioned in the aircraft and which is for converting video signals from the camera into audio signals, first transceiver means which is positioned in the aircraft and which is for transmitting the audio signals from the first transducer means and for receiving command signals, second transceiver means which is positioned in a command base remote from the aircraft and which is for receiving the audio signals from the first transceiver means and for sending the command signals, second transducer means which is positioned in the command base and which is for converting the audio signals received by the second transceiver means into video signals, and at least one television monitor for providing a visual display consequent upon receiving the video signals from the second transducer means.

The aircraft surveillance system of the invention is especially useful for surveying the inside of an aircraft during a hijack. When a hijack occurs, the hijackers invariably inform ground control that they have hijacked the aircraft and, with the surveillance system of the present invention, it is only necessary for the ground control to issue an appropriate command signal to cause the camera to operate and to cause pictures of the hijack to be transmitted back to a television monitor in ground control. The transmitted pictures can be enlarged as may be desired, for example to ascertain the identity of a hijacker and/or whether or not the hijacker has a real gun, grenade or the like or whether the gun, grenade or the like is an imitation device. It will thus be apparent, that by the time the aircraft is forced to land at its destination determined by the hijacker, ground control will be in a good position to know exactly what action to take.

The aircraft surveillance system of the invention is also of a special use for surveying land. In this case, the aircraft will usually be a slow flying aircraft such for example as a helicopter, as opposed to a passenger flying aircraft. Pictures of the land can be relayed to a command base and the pictures may help to establish the position of terrorists, escaped prisoners or the like on the land.

The pictures can be displayed as black and white or colour pictures.

The command base will usually be a ground command base but, if desired, the command base

could be in another aircraft, a ship or a vehicle.

The command signals will usually be start-up signals for initiating operation of the aircraft surveillance system. However, if desired, the start-up signals may be other signals for actuating the commencement of other desired functions.

The first and the second transceiver means may be substantially identical pieces of equipment.

The first transducer means will usually convert the video signals from the camera to audio signals on cassette tape. The audio signals will usually be transmitted from the aircraft to the command base as radio signals. For example, the audio signals may be transmitted on normal aircraft radio frequencies such for example as the aircraft Mayday frequency.

Advantageously, the first transducer means and the first transceiver means are housed together in a single piece of equipment. Similarly, the second transducer means and the second transceiver means are also advantageously housed together in a single piece of equipment. Such single pieces of equipment can be arranged to be mobile or static.

The transducer means and the transceiver means are advantageously in the form of a single piece of equipment known as IBSONSCAN II. The IBSONSCAN II is manufactured and sold by Ibsonmain Limited, of Uxbridge, Middlesex, England. Other equipment can of course be used if desired.

Preferably, the first and the second transceiver means record on to tape so that they have a playback facility for helping repeated surveillance of an area or an object in that area.

Usually, the first and the second transceiver means will have a rewind facility.

Any appropriate camera may be employed. Examples of cameras that may be employed are those manufactured by Ademco, Philips and Norbane. The cameras may be positioned where desired and appropriate in the aircraft. For example, for a passenger aircraft there will usually be one camera positioned in the cockpit together with a number of other cameras positioned in the passenger accommodation of the aircraft, the actual number of cameras employed being dependent upon the size of the passenger accommodation. For a jumbo jet, it is envisaged that at least four cameras will be required for the passenger accommodation, whilst it is envisaged that a minimum of two cameras will be required for the passenger accommodation of a Boeing 737 or a Boeing 757.

The cameras will usually be connected to the aircraft TPU power circuit to ensure that the power to the cameras cannot easily be switched off. Indeed, it is desirable that the entire aircraft surveillance system is such that it cannot be switched on or off or otherwise generally interfered with by aircraft personnel so that, in the event that the hijackers should know that they are being filmed, they cannot instruct the aircraft personnel to switch off the aircraft surveillance system.

The cameras can be positioned at random

positions in the same type of aircraft if desired in order that hijackers cannot easily know the location of the cameras. The cameras can also be concealed where possible, for example in overhead compartments, again so that their presence cannot easily be established.

Preferably, the aircraft surveillance system is such that the TV monitor has a picture hold facility.

The aircraft surveillance system may be one which has a visual display facility only, the signals passing from the aircraft to the command base then being signals which are only for permitting the visual display. Alternatively, the aircraft surveillance system may be one which has a visual display facility and also a speech facility, the signals passing from the aircraft to the command base then being first signals which permit the visual display and second signals which permit the speech.

An embodiment of the invention will now be described solely by way of example and with reference to the accompanying drawing which shows in diagrammatic form an aircraft surveillance system.

Referring to the drawing, there is shown an aircraft surveillance system 2 comprising an aircraft 4 and four closed circuit slow scan television cameras 6 which are positioned in the aircraft 4 and which are for surveying predetermined areas in the aircraft 4 such for example as the cockpit area and the passenger areas. One camera 6 will be employed for surveying each predetermined area.

The aircraft surveillance system 2 also comprises first transducer means 8 which is positioned in the aircraft 4 and which is for converting video signals from the cameras 6 into audio signals. First transceiver means 10 is positioned in the aircraft 4 and is for transmitting the audio signals from the first transducer means 8 and for receiving command signals.

The aircraft surveillance system 2 also comprises second transceiver means 12 which is positioned in a command base 14 remote from the aircraft 4 and which is for receiving audio signals from the first transceiver means 10 and for sending the command signals. The command base 14 is also provided with second transducer means 16 which is for converting the audio signals received by the second transceiver means 12 into video signals. A television monitor 18 is linked to the second transducer means 16 for providing a visual display consequent upon receiving the video signals from the second transducer means 16.

The cameras 6 are controlled by a control device 20 which is activated by receiving appropriate control signals from the first transducer means 8. The control device 20 can be used to make the cameras 6 pan, tilt, zoom or perform other functions. The control device 20 can also be used to activate lights or perform other control functions.

The first transducer means 8 and the first transceiver means 10 are advantageously formed together in a single housing as a single piece of equipment 22. Similarly, the second transceiver means 12 and the second transducer means 16 are advantageously formed together in a single housing

as a single piece of equipment 24. The equipment 22,24 is advantageously the equipment referred to above and known as IBSONSCAN II. The equipment 22,24 is such that it enables the pictures to be set as a continuous series of still pictures, updated every twenty two seconds, through standard voice frequency radio channels. The equipment 22 is able to take a television frame from the television cameras 6, convert the video signals to audio signals, record then, dial the command base 14, make a security check, and send the pictures, if desired accompanied by the time, date, source and any other required information. The equipment 24 is able to receive the signals from the equipment 22, make a security check, accept the signals, and record the signals. The equipment 24 contemporaneously restores the signal to a video mode and allows the picture to be displayed on the television monitor 18, together with any other transmitted information such for example as the above mentioned time, date and source.

The equipment 22,24 can control the entire aircraft surveillance system 2 and the transmitting equipment by sending up to sixty four separate instructions. If a poor connection is made, the equipment 22 can be instructed to rewind and replay its recording of an entire sequence. The equipment 24 can receive an entire transmission and it also has the facility to enable a single frame to be held on the television monitor 18. An entire transmission can be played back later for analysis and hard copying if desired.

It is envisaged that the aircraft surveillance system 2 will be especially useful for dealing with hijack situations and also for enabling aircraft border patrols to spot terroriste.

It is to be appreciated that the embodiment of the invention described above with reference to the accompanying drawing has been given by way of example only and that modifications may be effected. Thus, for example, more or less than the illustrated four cameras 6 may be employed, and more than one television monitor 18 may also be employed. Also, the cameras 6 could be directed outside an aircraft to survey a predetermined area such as a border or a coastline.

Claims

1. An aircraft surveillance system comprising an aircraft, at least one closed circuit slow scan television camera which is positioned in the aircraft and which is for surveying a predetermined area, first transducer means which is positioned in the aircraft and which is for converting video signals from the camera into audio signals, first transceiver means which is positioned in the aircraft and which is for transmitting the audio signals from the first transducer means and for receiving command signals, second transceiver means which is positioned in a command base remote from the aircraft and which is for receiving the audio signals from the first transceiver means and for

sending the command signals, second transducer means which is positioned in the command base and which is for converting the audio signals received by the second transceiver means into video signals, and at least one television monitor for providing a visual display consequent upon receiving the video signals from the second transducer means. 5

2. An aircraft surveillance system according to claim 1 in which the first transducer means is for converting the video signals from the camera to audio signals on cassette tape. 10

3. An aircraft surveillance system according to claim 1 or claim 2 in which the first transducer means and the first transceiver means are housed together in a single piece of equipment, and in which the second transducer means and the second transceiver means are also housed together in a single piece of equipment. 15

4. An aircraft surveillance system according to any one of the preceding claims in which the first and the second transceiver means record on to tape so that they have a play back facility for helping repeated surveillance of an area of an object in that area. 20

5. An aircraft surveillance system according to any one of the preceding claims in which the first and the second transceiver means have a rewind facility. 25

6. An aircraft surveillance system according to any one of the preceding claims in which the television monitor has a picture hold facility. 30

7. An aircraft surveillance system according to any one of the preceding claims and which has a visual display facility only, the signals passing from the aircraft to the command base then being signals which are only for permitting the visual display. 35

8. An aircraft surveillance system according to any one of claims 1 - 6 and which has a visual display facility and also a speech facility, the signals passing from the aircraft to the command base then being first signals which permit the visual display and second signals which permit the speech. 40

45

50

55

60

65

4

0232031

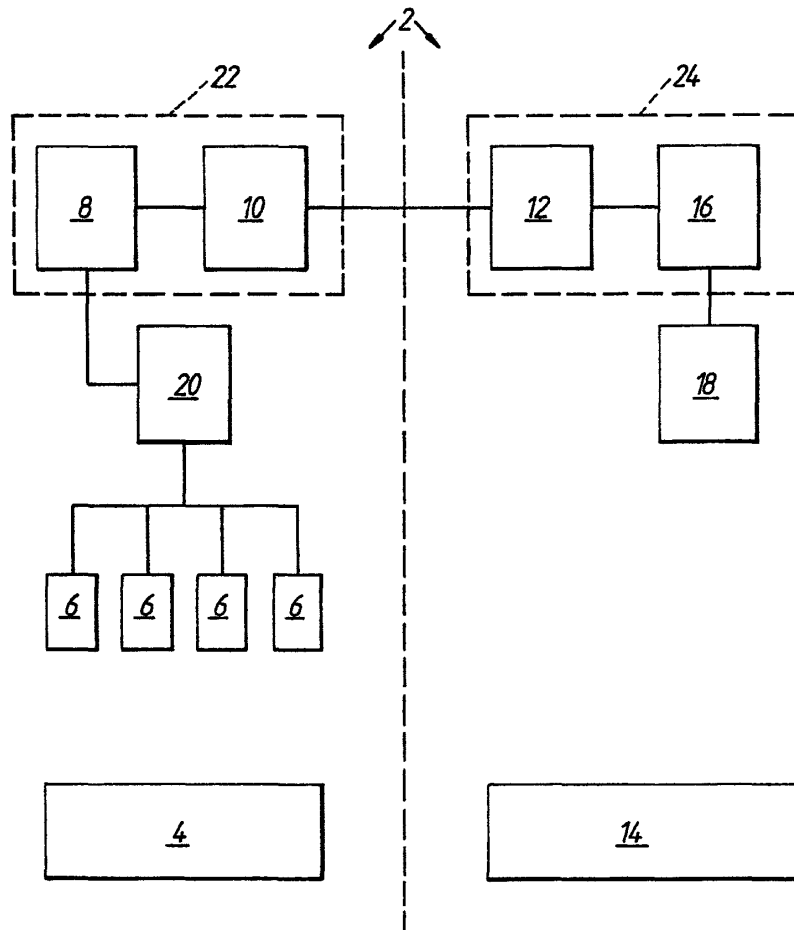

EUROPEAN PATENT APPLICATION

Application number: **87300392.5**

Int. Cl. 4: **G08B 13/18**

Date of filing: **16.01.87**

Priority: **03.02.86 GB 8602575**

Applicant: **SAYZEN LIMITED**
53 Brookwood Road
Southfields London SW18 5BQ(GB)

Date of publication of application:
12.08.87 Bulletin 87/33

Inventor: **Hale, Christopher John**
53 Brookwood Road
Southfields London, SW18 5BQ(GB)

Designated Contracting States:
AT BE CH DE ES FR GR IT LI LU NL SE

Representative: **Jones, Graham H.**
Graham Jones & Company 77 Beaconsfield
Road Blackheath
London SE3 7LG(GB)

Date of deferred publication of the search report:
08.02.89 Bulletin 89/06

An aircraft surveillance system.

An aircraft surveillance system (2) comprising an aircraft (4), at least one closed circuit slow scan television camera (6) which is positioned in the aircraft (4) and which is for surveying a predetermined area, first transducer means (8) which is positioned in the aircraft (4) and which is for converting video signals from the camera (6) into audio signals, first transceiver means (10) which is positioned in the aircraft (4) and which is for transmitting the audio signals from the first transducer means (8) and for receiving command signals, second transceiver means (12) which is positioned in a command base (14) remote from the aircraft (4) and which is for receiving the audio signals from the first transceiver means (10) and for sending the command signals, second transducer means (16) which is positioned in the command base (14) and which is for converting the audio signals received from the second transceiver means (12) into video signals, and at least one television monitor (18) for providing a visual display consequent upon receiving the video signals from the second transducer means (16).

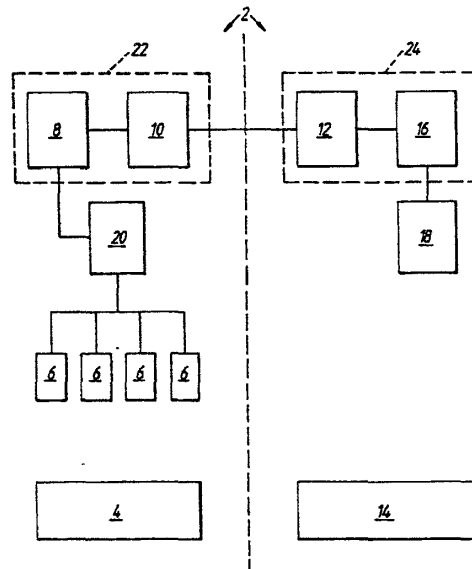

EP 0 232 031 A3



DOCUMENTS CONSIDERED TO BE RELEVANT			
Category	Citation of document with indication, where appropriate, of relevant passages	Relevant to claim	CLASSIFICATION OF THE APPLICATION (Int. Cl. 4)
Y	EP-A-0 137 320 (ATIS) * Page 3, line 33 - page 4, line 33; figure 1 *	1-7	G 08 B 13/18
Y	EP-A-0 028 933 (ASCOTTS LTD) * Page 4, line 23 - page 5, line 29; figure 1 *	1-7	
A	CH-A- 651 984 (DUCROT) * Whole document *	1,8	
A	FR-A-2 551 240 (ARPHI) * Abstract *	1	
			TECHNICAL FIELDS SEARCHED (Int. Cl.4)
			G 08 B
The present search report has been drawn up for all claims			
Place of search THE HAGUE		Date of completion of the search 22-11-1988	Examiner SGURA S.
CATEGORY OF CITED DOCUMENTS		T : theory or principle underlying the invention E : earlier patent document, but published on, or after the filing date D : document cited in the application L : document cited for other reasons & : member of the same patent family, corresponding document	
X : particularly relevant if taken alone Y : particularly relevant if combined with another document of the same category A : technological background O : non-written disclosure P : intermediate document			

EPO FORM 1503 03.82 (P0401)



EUROPEAN PATENT APPLICATION

Application number : **94301261.7**

Int. Cl.⁵ : **G08G 5/06**

Date of filing : **23.02.94**

Priority : **26.02.93 US 23978**

Date of publication of application :
31.08.94 Bulletin 94/35

Designated Contracting States :
DE ES FR GB IT NL SE

Applicant : **RAYTHEON COMPANY**
141 Spring Street
Lexington Massachusetts 02173 (US)

Inventor : **Hoover, Peter L.**
20 Kelleher Street
Marlboro, MA 01752 (US)

Representative : **Jackson, David Spence et al**
REDDIE & GROSE
16, Theobalds Road
London, WC1X 8PL (GB)

Infrared vehicle identification system.

An infrared vehicle identification system [109] comprising a microprocessor controlled infrared (IR) transmitter [112] located on an aircraft nose wheel landing strut [111] and an infrared receiver [128] including a microprocessor [44] enclosed in a plurality of edge light assemblies [20] located along surface pathways of an airport including runways and taxiways. The infrared transmitter [112] comprises an array of light emitting diodes [120] (LEDs) arranged in a semicircle within the horizontal plane. The transmitter [112] emits a plurality of fields [121, Fig.13] of encoded data to provide vehicle identification and position information. One field [122] comprises a steady stream of pulses that allows the IR receiver [128] to calculate the baud rate of the transmitter [112] and automatically adjust its internal timing. The other fields include a unique word [123] for marking the beginning of a message, the number [124] of characters in the message, the vehicle identification number [125], the vehicle position [126] and a checksum [127]. The latter [127] ensures that a complete and correct message has been received. If the transmitted message is interrupted for any reason, the checksum [127] will detect it and the messages will be voided. The IR receiver [128] relays a valid message of vehicle identification [125] and position [126] to a central computer system [12, Fig.1] at the airport control tower via the edge light assembly power wiring [21, Fig.1].

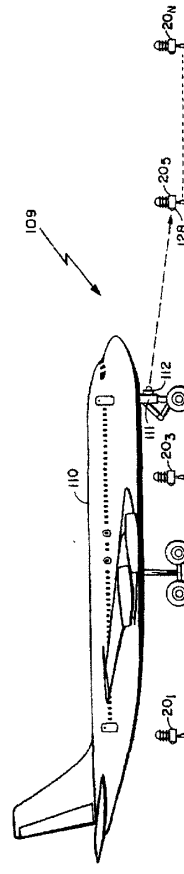

FIG. 10

EP 0 613 109 A1

Background of the Invention

This invention relates to identification of airport surface traffic and in particular to an apparatus and method for detecting and identifying aircraft or other vehicle movement on airport taxiways, runways and other surface areas.

5 Currently, ground control of aircraft at an airport is done visually by the air traffic controller in the tower. Low visibility conditions sometimes make it impossible for the controller to see all parts of the field. Ground surface radar can help in providing coverage during low visibility conditions; it plays an important part in the solution of the runway incursion problem but cannot solve the entire problem. A runway incursion is defined as "any occurrence at an airport involving an aircraft, vehicle, person, or object on the ground that creates a collision hazard or results in loss of separation with an aircraft taking off, intending to take off, landing, or intending to land." The U.S. Federal Administration Agency (FAA) has estimated that it can only justify the cost of ground surface radar at 29 of the top 100 airports in the United States. However, such radar only provides location information; it cannot alert the controller to possible conflicts between aircraft.

10 In the prior art, an airport control and monitoring system has been used to sense when an airplane reaches a certain point on a taxiway and controls switching lights on and off to indicate to the pilot when he may proceed on to a runway. Such a system sends microwave sensor information to a computer in the control tower. The computer comprises software for controlling the airport lighting and for providing fault information on the airport lighting via displays or a control panel to an operator. Such a system is described in sales information provided on a Bi-directional Series 7 Transceiver (BRITEE) produced by ADB-ALNACO, Inc., A Siemens Company, of Columbus, Ohio. However, such a system does not show the location of all vehicles on an airfield and is not able to detect and avoid a possible vehicle incursion.

15 A well known approach to airport surface traffic control has been the use of scanning radars operating at high frequencies such as K-band in order to obtain adequate definition and resolution. An existing airport ground traffic control equipment of that type is known in the art as Airport Surface Detection Equipment (ASDE). However, such equipment provides surveillance only, no discrete identification of aircraft on the surface being available. Also there is a need for a relatively high antenna tower and a relatively large rotation antenna system thereon.

20 Another approach to airport ground surveillance is a system described in U. S. Patent No. 3,872,474, issued March 18, 1974, to Arnold M. Levine and assigned to International Telephone and Telegraph Corporation, New York, NY, referred to as LOCAR (Localized Cable Radar) which comprises a series of small, lower powered, narrow pulses, transmitting radars having limited range and time sequenced along opposite sides of a runway ramp or taxiway. In another U. S. Patent No. 4,197,536, issued on April 8, 1980, to Arnold M. Levine, an airport surface identification and control system is described for aircraft equipped with ATCRBS (Air Traffic Control Radio Beacon System) and ILS (Instrument Landing System). However, these approaches are expensive, require special cabling and for identification purposes require expensive equipment to be included on the aircraft and other vehicles.

25 Another approach to vehicle identification such as types of aircraft by identifying the unique characteristic of the "footprint" presented by the configuration of wheels unique to a particular type of vehicle is described in U.S. Patent No. 3,872,283, issued March 18, 1975, to Gerald R. Smith et al. and assigned to The Cadre Corporation of Atlanta Georgia.

30 An automatic system for surveillance, guidance and fire-fighting at airports using infrared sensors is described in U. S. Patent No. 4,845,629, issued July 4, 1989 to Maria V. Z. Murga. The infrared sensors are arranged along the flight lanes and their output signals are processed by a computer to provide information concerning the aircraft movements along the flight lanes. Position detectors are provided for detecting the position of aircraft in the taxiways and parking areas. However, such system does not teach the use of edge lights along the runways and taxiways along with their associated wiring and it is not able to detect and avoid a possible vehicle incursion.

35 The manner in which the invention deals with the disadvantages of the prior art to provide a low cost infrared vehicle identification system will be evident as the description proceeds.

Summary of the Invention

40 Accordingly, it is therefore an object of this invention to provide a low cost infrared system that identifies aircraft or other vehicles on airport taxiways and runways.

45 It is also an object of this invention to provide at an airport a low cost aircraft or vehicle identification system using existing edge light assemblies and associated wiring along runways and taxiways.

50 It is another object of this invention to provide an infrared vehicle identification system that generates a

graphic display of the airport showing the location of all ground traffic including direction and velocity data and identifies such ground traffic.

5 The objects are further accomplished by providing a vehicle identification system for identifying aircraft and other vehicles on surface pathways including runways and other areas of an airport comprising means disposed on the aircraft and other vehicles for transmitting identification message data, means disposed in each of a plurality of light assembly means on the airport for receiving and decoding the message data from the transmitting means, means for providing power to each of the plurality of light assembly means, means for processing the decoded identification message data generated by the receiving and decoding means in 10 each of the plurality of light assembly means, means for providing data communication between each of the light assembly means and the processing means, and the processing means comprises means for providing a graphic display of the airport comprising symbols representing the aircraft and other vehicles, each of the symbols having the identification message data displayed. The transmitting means comprises means for creating unique message data which includes aircraft and flight identification, and infrared means coupled to the message creating means for transmitting a coded stream of the message data. The message data further includes position information. The receiving and decoding means comprises an infrared sensor. The receiving and decoding means comprises microprocessor means coupled to the infrared sensor for decoding the message data. The plurality of light assembly means are arranged in two parallel rows along runways and taxiways of the airport. The light assembly means comprises light means coupled to the lines of the power providing means for lighting the airport, vehicle sensing means for detecting aircraft or other vehicles on the airport, microprocessor means coupled to the receiving and decoding means, the light means, the vehicle sensing means and the data communication means for decoding the identification message data, and the data communication means being coupled to the microprocessor means and the lines of the power providing means. The symbols representing aircraft and other vehicles comprise icons having a shape indicating type of aircraft or vehicle. The processing means determines a location of the symbols on the graphic display of the airport in accordance with data received from the light assembly means. 25

The objects are further accomplished by a vehicle identification system for surveillance and identification of aircraft and other vehicles on an airport comprising a plurality of light circuits on the airport, each of the light circuits comprises a plurality of light assembly means, means for providing power to each of the plurality of light circuits and to each of the light assembly means, means in each of the light assembly means for sensing ground traffic on the airport, means disposed on the aircraft and other vehicles for transmitting identification message data, means disposed in each of the light assembly means for receiving and decoding the message data from the transmitting means, means for processing ground traffic data from the sensing means and decoded message data from each of the light assembly means for presentation on a graphic display of the airport, means for providing data communication between each of the light assembly means and the processing means, 35 the processing means comprises means for providing such graphic display of the airport comprising symbols representing the ground traffic, each of the symbols having direction, velocity and the identification message data displayed. Each of the light circuits are located along the edges of taxiways or runways on the airport. The sensing means comprises infrared detectors. The transmitting means comprises means for creating unique message data which includes aircraft and flight identification, and infrared means coupled to the message creating means for transmitting a coded stream of the message data. The message data further comprises position information. The receiving and decoding means comprises an infrared sensor. The receiving and decoding means comprises microprocessor means coupled to the infrared sensor for decoding the message data. The plurality of light assembly means of the light circuits being arranged in two parallel rows along runways and taxiways of the airport. The light assembly means comprises light means coupled to the lines of the power providing means for lighting the airport, the ground traffic sensing means for detecting aircraft or other vehicles on the airport, microprocessor means coupled to the receiving and decoding means, the light means, the ground traffic sensing means and the data communication means for decoding the identification message data and processing a detection signal from the ground traffic sensing means, and the data communication means being coupled to the microprocessor means and the lines of the power providing means. 45 The light assembly means further comprises a photocell means coupled to the microprocessor means for detecting the light intensity of the light means. The light assembly means further comprises a strobe light coupled to the microprocessor means. The processing means comprises redundant computers for fault tolerance operation. The symbols representing the ground traffic comprise icons having a shape indicating type of aircraft or vehicle. The processing means determines a location of the symbols on the graphic display of the airport in accordance with the data receive from the light assembly means. The processing means determines a future path of the ground traffic based on a ground clearance command, the future path being shown on the graphic display. The processing means further comprises means for predicting an airport incursion. The power providing means comprises constant current power means for providing a separate line to each of the plurality of 55

light circuits, and network bridge means coupled to the constant current power means for providing a communication channel to the processing means for each line of the constant current power means.

The objects are further accomplished by providing a method of providing a vehicle identification system for identifying aircraft and other vehicles on surface pathways including runways and other areas of an airport comprising the steps of transmitting identification message data with means disposed on the aircraft and other vehicles, receiving and decoding the message data from the transmitting means with means disposed in each of a plurality of light assembly means on the airport, providing power to each of the plurality of light assembly means, processing the decoded identification message data generated by the receiving and decoding means in each of the plurality of light assembly means, providing data communication between each of the light assembly means and the processing means, and providing a graphic display of the airport with the processing means comprising symbols representing the aircraft and other vehicles, each of the symbols having the identification message data displayed. The step of transmitting identification message data comprises the steps of creating unique message data which includes aircraft and flight identification, and transmitting a coded stream of the message data with infrared means coupled to the message creating means. The step of transmitting message data further includes transmitting position information. The step of receiving and decoding the message data includes using an infrared sensor. The step of receiving and decoding the message data further comprises the step of coupling microprocessor means to the infrared sensor for decoding the message data. The step of receiving and decoding the message data with means disposed in the plurality of light assembly means further comprises the step of arranging the plurality of light assembly means in two parallel rows along runways and taxiways of the airport. The step of providing a graphic display comprising symbols representing aircraft and other vehicles further comprises the step of providing icons having a shape indicating type of aircraft or vehicle. The step of providing a graphic display comprises the step of determining a location of the symbols on the graphic display of the airport in accordance with data received from the light assembly means.

25

Brief Description of the Drawings

Other and further features of the invention will become apparent in connection with the accompanying drawings wherein:

30

FIG. 1 is a block diagram of an airport vehicle incursion avoidance system;

FIG. 2 is a block diagram of an edge light assembly showing a sensor electronics unit coupled to an edge light of an airfield lighting system;

FIG. 3 is a pictorial diagram of the edge light assembly showing the edge light positioned above the sensor electronics unit;

35

FIG. 4 is a diagram of an airfield runway or taxiway having a plurality of edge light assemblies positioned along each side of the runway or taxiway for detecting various size aircraft as shown;

FIG. 5 is a block diagram of the central computer system shown in FIG. 1;

FIG. 6 shows eleven network variables used in programming the microprocessor of an edge light assembly to interface with a sensor, a light and a strobe light;

40

FIG. 7 is a block diagram showing an interconnection of network variables for a plurality of edge light assemblies located on both sides of a runway, each comprising a sensor electronics unit 10 positioned along a taxiway or runway;

FIG. 8 shows a graphic display of a typical taxiway/runway on a portion of an airport as seen by an operator in a control tower, the display showing the location of vehicles as they are detected by the sensors mounted in the edge light assemblies located along taxiways and runways;

45

FIG. 9 is a block diagram of the data flow within the system shown in FIG. 1 and FIG. 5;

FIG. 10 is a pictorial diagram of an infrared identification system showing an IR transmitter mounted on an airplane wheel strut and an IR receiver mounted in an edge light assembly of an airport lighting system;

FIG. 11 is a block diagram of an IR transmitter of an IR vehicle identification system;

50

FIG. 12 shows a top view of the IR transmitter mounted on an airplane wheel strut providing a 195° area of coverage generated by an IR light emitting diode array in the IR transmitter;

FIG. 13 shows data fields of a coded data stream transmitted by the IR transmitter;

FIG. 14 is a block diagram of an IR receiver of the IR vehicle identification system;

55

FIG. 15 is a flow chart of an IR message routine which is a communication protocol continuously performed in an IR receiver microprocessor; and

FIG. 16 is a flow chart of a vehicle sensor routine which is continuously performed in an IR receiver microprocessor.

Description of the Preferred Embodiment

Referring to FIG. 1 a block diagram of an airport vehicle incursion avoidance system 10 is shown comprising a plurality of light circuits 18_{1-n}, each of said light circuits 18_{1-n} comprises a plurality of edge light assemblies 20_{1-n} connected via wiring 21_{1-n} to a lighting vault 16 which is connected to a central computer system 12 via a wide area network 14. Each of the edge light assemblies 20_{1-n} comprises an infrared (IR) detector vehicle sensor 50 (FIG. 2).

The edge light assemblies 20_{1-n} are generally located along side the runways and taxiways of the airport with an average 100 foot spacing and are interconnected to the lighting vault 16 by single conductor series edge light wiring 21_{1-n}. Each of the edge light circuits 18_{1-n} is powered via the wiring 21_{1-n} by a constant current supply 24_{1-n} located in the lighting vault 16.

Referring now to FIG. 1 and FIG. 2, communication between the edge light assemblies 20_{1-n} and the central computer system 12 is accomplished with LON Bridges 22_{1-n} interconnecting the edge light wiring 21_{1-n} with the Wide Area Network 14. Information from a microprocessor 44 located in each edge light assembly 20_{1-n} is coupled to the edge light wiring 21_{1-n} via a power line modem 54. The LON bridges 22_{1-n} transfers message information from the edge light circuits 18_{1-n} via the wiring 21_{1-n} to the wide area network 14. The wide area network 14 provides a transmission path to the central computer system 12. These circuit components also provide the return path communications link from the central computer system 12 to the microprocessor 44 in each edge light assembly 20_{1-n}. Other apparatus and methods, known to one of ordinary skill in the art, for data communication between the edge light assemblies 20_{1-n} and the central computer system 12 may be employed, such as radio techniques, but the present embodiment of providing data communication on the edge light wiring 21_{1-n} provides a low cost system for present airports. The LON Bridge 22 may be embodied by devices manufactured by Echelon Corporation of Palo Alto, California. The wide area network 14 may be implemented by one of ordinary skill in the art using standard Ethernet or Fiber Distributed Data Interface (FDDI) components. The constant current supply 24 may be embodied by devices manufactured by Crouse-Hinds of Winslow, Connecticut.

Referring now to FIG. 2 and FIG. 3, FIG. 3 shows a pictorial diagram of the edge light assembly 20_{1-n}. The edge light assembly 20_{1-n} comprises a bezel including an incandescent lamp 40 and an optional strobe light assembly 48 (FIG. 2) which are mounted above an electronics enclosure 43 comprising a vehicle sensor 50. The electronics enclosure 43 sits on the top of a tubular shaft extending from a base support 56. The light assembly bezel with lamp 40 and base support 56 may be embodied by devices manufactured by Crouse-Hinds of Winslow, Connecticut.

A block diagram of the contents of the electronics enclosure 43 is shown in FIG. 2 which comprises a coupling transformer 53 connected to the edge light wiring 21_{1-n}. The coupling transformer 53 provides power to both the incandescent lamp 40 via the lamp control triac 42 and the microprocessor power supply 52; in addition, the coupling transformer 53 provides a data communication path between the power line modem 54 and the LON Bridges 22_{1-n} via the edge light wiring 21_{1-n}. The microprocessor 44 provides the computational power to run the internal software program that controls the edge light assemblies 20_{1-n}. The microprocessor 44 is powered by the microprocessor power supply 52. Also connected to the microprocessor 44 is the lamp control triac 42, a lamp monitoring photo cell 46, the optional strobe light assembly 48, the vehicle sensor 50, and the data communications modem 54. The microprocessor 44 is used to control the incandescent edge light 40 intensity and optional strobe light assembly 48. The use of the microprocessor 44 in each light assembly 20_{1-n} allows complete addressable control over every light on the field. The microprocessor 44 may be embodied by a VLSI device manufactured by Echelon Corporation of Palo Alto, California 94304, called the Neuron® chip.

Still referring to FIG. 2, the sensor 50 in the present embodiment comprises an infrared (IR) detector and in other embodiments may comprise other devices such as proximity detectors, CCD cameras, microwave motion detectors, inductance loops, or laser beams. The program in the microprocessor 44 is responsible for the initial filtering of the sensor data received from the sensor 50 and responsible for the transmission of such data to the central computer system 12. The sensor 50 must perform the following functions: detect a stationary object, detect a moving object, have a range at least half the width of the runway or taxiway, be low power and be immune to false alarms. This system design does not rely on just one type of sensor. Since sensor fusion functions are performed within the central computer system 12, data inputs from all different types of sensors are acceptable. Each sensor relays a different view of what is happening on the airfield and the central computer system 12 combines them. There are a wide range of sensors that may be used in this system. As a new sensor type becomes available, it can be integrated into this system with a minimum of difficulty. The initial sensor used is an IR proximity detector based around a piezoelectric strip. These are the kind of sensors you use at home to turn on your flood lights when heat and/or movement is detected. When the sensor output pro-

vides an analog signal, an analog-to-digital converter readily known in the art may be used to interface with the microprocessor 44.

Another proximity detector that can be used is based around a microwave Gunn diode oscillator. These are currently in use in such applications as Intrusion Alarms, Door Openers, Distance Measurement, Collision Warning, Railroad Switching, etc. These types of sensors have a drawback because they are not passive devices and care needs to be taken to select frequencies that would not interfere with other airport equipment. Finally, in locations such as the hold position lines on taxiways, solid state laser and detector combinations could be used between adjacent taxiway lights. These sensor systems create a beam that when broken would identify the location of the front wheel of the airplane. This type of detector would be used in those locations where the absolute position of a vehicle was needed. The laser beam would be modulated by the microprocessor 44 to avoid the detector being fooled by any other stray radiation.

Referring to FIG. 2 and FIG. 4, a portion of an airport runway 64 or taxiway is shown having a plurality of edge light assemblies 20₁₋₈ positioned along each side of the runway or taxiway for detecting various size airplanes or vehicles 60, 62. The dashed lines represent the coverage area of the sensors 50 located in each edge light assembly 20₁₋₈ positioned along each side of the runway 64 or taxiway to insure detection of any airplane 60, 62 or other vehicles traveling on such runway 64 or taxiway. The edge light assemblies 20_{1-n} comprising the sensor 50 are logically connected together in such a way that an entire airport is sensitized to the movement of vehicles. Node to node communication takes place to verify and identify the location of the vehicles. Once this is done a message is sent to the central computer system 12 reporting the vehicles location. Edge lights assemblies (without a sensor electronics unit 43) and taxiway power wiring currently exist along taxiways, runways and open areas of airports, therefore, the sensor electronics unit 43 is readily added to existing edge lights and existing taxiway power wiring without the inconvenience and expense of closing down runways and taxiways while installing new cabling.

Referring now to FIG. 1, FIG. 5, FIG. 8 and FIG. 9, the central computer system 12 is generally located at a control tower or terminal area of an airport and is interconnected to the LON Bridges 22_{1-n} located in the lighting vault 16 with a Wide Area Network 14. The central computer system 12 comprises two redundant computers, computer #1 26 and computer #2 28 for fault tolerance, the display 30, speech synthesis units 29 & 31, alert lights 34, keyboard 27 and a speech recognition unit 33, all of these elements being interconnected by the wide area network 14 for the transfer of information. The two computers 26 and 28 communicate with the microprocessors 44 located in the edge light assemblies 20_{1-n}. Data received from the edge light assembly 20_{1-n} microprocessors 44 are used as an input to a sensor fusion software module 101 (FIG. 9) run on the redundant computers 26 and 28. The output of the sensor fusion software module 101 operating in the computers 26, 28 is used to drive the CRT display 30 which displays the location of each vehicle on the airport taxiway and runways as shown in FIG. 8. The central computer system 12 may be embodied by devices manufactured by IBM Corporation of White Plains, New York. The Wide Area Network 14 may be embodied by devices manufactured by 3Com Corporation of Santa Clara, California. The speech synthesis units 29, 31 and the speech recognition unit 33 may be embodied by devices manufactured by BBN of Cambridge, Massachusetts.

The speech synthesis unit 29 is coupled to a speaker 32. Limited information is sent to the speech synthesis unit 29 via the wide area network 14 to provide the capability to give an air traffic controller a verbal alert. The speech synthesis unit 31 is coupled to a radio 37 having an antenna 39 to provide the capability to give the pilots a verbal alert. The voice commands from the air traffic controller to the pilots are captured by microphone 35 and sent to the pilots via radio 36 and antenna 38. In the present embodiment a tap is made and the speech information is sent to both the radio 36 and the speech recognition unit 33 which is programmed to recognize the limited air traffic control vocabulary used by a controller. This includes airline names, aircraft type, the numbers 0-9, the name of the taxiways and runways and various short phrases such as "hold short", "expedite" and "give way to." The output of the speech recognition unit 33 is fed to the computers 26, 28.

Referring again to FIG. 2, the power line modem 54 provides a data communication path over the edge light wiring 21_{1-n} for the microprocessor 44. This two way path is used for the passing of command and control information between the various edge light assemblies 20_{1-n} and the central computer system 12. A power line transceiver module in the power line modem 54 is used to provide a data channel. These modules use carrier current approach to create the data channel. Power line modems that operate at carrier frequencies in the 100 to 450 Khz band are available from many manufacturers. These modems provide digital communication paths at data rates of up to 10,000 bits per second utilizing direct sequence spread spectrum modulation. They conform to FCC power line carrier requirements for conducted emissions, and can work with up to 55 dB of power line attenuation. The power line modem 54 may be embodied by a device manufactured by Echelon Corporation of Palo Alto, California 94304, called the PLT-10 Power Line Transceiver Module.

The data channel provides a transport layer or lowest layer of the open system interconnection (OSI) protocol used in the data network. The Neuron[®] chip which implements the microprocessor 44 contains all of the firmware required to implement a 7 layer OSI protocol. When interconnected via an appropriate medium the Neuron[®] chips automatically communicate with one another using a robust Collision Sense Multiple Access (CSMA) protocol with forward error corrections, error checking and automatic retransmission of missed messages (ARQ).

The command and control information is placed in data packets and sent over the network in accordance with the 7 Layer OSI protocol. All messages generated by the microprocessor 44 and destined for the central computer system 12 are received by the network bridge 22 via the power lines 21_{1-n} and routed to the central computer system 12 over the wide area network 14.

The Neuron[®] chip of the microprocessor 44 comprises three processors (not shown) and the firmware required to support a full 6 layer open systems interconnection (OSI) protocol. The user is allocated one of the processors for the application code. The other two processors give the application program access to all of the other Neuron[®] chips in the network. This access creates a Local Operating Network or LON. A LON can be thought of as a high level local area network LAN. The use of the Neuron[®] chip for the implementation of this invention, reduces the amount of custom hardware and software that otherwise would have to be developed.

Data from the sensor electronic unit 43 of the edge light assemblies 20_{1-n} is coupled to the central computer system 12 via the existing airport taxiway lighting power wiring 21. Using the existing edge light power line to transfer the sensor data into a LON network has many advantages. As previously pointed out, the reuse of the existing edge lights eliminates the inconvenience and expense of closing down runways and taxiways while running new cable and provides for a low cost system.

The Neuron[®] chip allows the edge light assemblies 20_{1-n} to automatically communicate with each other at the applications level. This is accomplished through network variables which allow individual Neuron[®] chips to pass data between themselves. Each Neuron[®] 'C' program comprises both local and network variables. The local variables are used by the Neuron[®] program as a scratch pad memory. The network variables are used by the Neuron[®] program in one of two ways, either as a network output variables or a network input variables. Both kinds of variables can be initialized, evaluated and modified locally. The difference comes into play in that once a network output variable is modified, network messages are automatically sent to each network input variable that is linked to that output variable. This variable linking is done at installation time. As soon as a new value of a network input variable is received by a Neuron[®] chip, the code is vectored off to take appropriate action based upon the value of the network input variable. The advantage to the program is that this message passing scheme is entirely transparent since the message passing code is part of the embedded Neuron[®] operating system.

Referring now to FIG. 6, eleven network variables have been identified for a sensor program in each microprocessor 44 of the edge light assemblies 20_{1-n}. The sensor 50 function has two output variables: prelim_detect 70 and confirmed_detect 72. The idea here is to have one output trigger whenever the sensor 50 detects movement. The other output does not trigger unless the local sensor and the sensor on the edge light across the runway both spot movement. Only when the detection is confirmed will the signal be fed back to the central computer system 12. This technique of confirmation helps to reduce false alarms in order to implement this technique the adjacent sensor 50 has an input variable called adj_prelim_detect 78 that is used to receive the other sensors prelim_detect output 70. Other input variables are upstream_detect 74 and downstream_detect 76 which are used when chaining adjacent sensors together. Also needed is a detector_sensitivity 80 input that is used by the central computer system 12 to control the detection ability of the sensor 50.

The incandescent light 40 requires two network variables, one input and the other an output variable. The input variable light_level 84 would be used to control the light's brightness. The range would be OFF or 0% all the way to FULL ON or 100%. This range from 0% to 100% would be made in 0.5% steps. Since the edge light assembly 20_{1-n} also contains the photocell 46, an output variable light_failure 84 is created to signal that the lamp did not obtain the desired brightness.

The strobe light 48 requires three input variables. The strobe-mode 86 variable is used to select either the OFF, SEQUENTIAL, or ALTERNATE flash modes. Since the two flash modes require a distinct pattern to be created, two input variables active_delay 88 and flash_delay 90 are used to time align the strobe flashes. By setting these individual delay factors and then addressing the Neuron[®] chips as a group, allows the creation of a field strobe pattern with just one command.

Referring now to FIG. 7, a block diagram of an interconnection of network variables for a plurality of edge light assemblies 20_{1-n} located on both sides of a runway is shown, each of the edge light assemblies 20_{1-n} comprising a microprocessor 44. Each Neuron[®] program in the microprocessor 44 is designed with certain network input and output variables. The user writes the code for the Neuron[®] chips in the microprocessor 44

assuming that the inputs are supplied and that the outputs are used. To create an actual network the user has to "wire up" the network by interconnecting the individual nodes with a software linker. The resulting distributed process is best shown in schematic form, and a portion of the network interconnect matrix is shown in Figure 7. The `prelim_detect` 70 output of a sensor node 44_i is connected to the `adj_primary_detect` 92 input of the sensor node 44_4 across the taxiway. This is used as a means to verify actual detections and eliminate false reports. The communications link between these two nodes 44_i and 44_4 is part of the distributed processing. The two nodes communicate among themselves without involving the central computer system 12. If in the automatic mode or if instructed by the controller, the system will also alert the pilots via audio and visual indications.

Referring again to FIG. 1 and FIG. 4, the central computer system 12 tracks the movement of vehicles as they pass from the sensor 50 to sensor 50 in each edge light assembly 20_{1-n} . Using a variation of a radar automatic track algorithm, the system can track position, velocity and heading of all aircraft or vehicles based upon the sensor 50 readings. New vehicles are entered into the system either upon leaving a boarding gate or landing. Unknown vehicles are also tracked automatically. Since taxiway and runway lights are normally across from each other on the pavement (as shown in FIG. 4 and FIG. 7), the microprocessor 44 in each edge lights assembly 20_{1-n} is programmed to combine their sensor 50 inputs and agree before reporting a contact. A further refinement is to have the microprocessor 44 check with the edge light assemblies 20_{1-n} on either side of them to see if their sensors 50 had detected the vehicle. This allows a vehicle to be handed off from sensor electronic unit 43 to sensor electronic unit 43 of each edge light assembly 20_{1-n} as it travels down the taxiway. This also assures that vehicle position reports remain consistent. Vehicle velocity may also be calculated by using the distance between sensors, the sensor pattern and the time between detections.

Referring to FIG. 5 and FIG. 8, the display 30 is a color monitor which provides a graphical display of the airport, a portion of which is shown in FIG. 8. This is accomplished by storing a map of the airport in the redundant computers 26 and 28 in a digital format. The display 30 shows the location of airplanes or vehicles as they are detected by the sensors 50 mounted in the edge light assemblies 20_{1-n} along each taxiway and runway or other airport surface areas. All aircraft or vehicles on the airport surface are displayed as icons, with the shape of the icons being determined by the vehicle type. Vehicle position is shown by the location of the icon on the screen. Vehicle direction is shown by either the orientation of the icon or by an arrow emanating from the icon. Vehicle status is conveyed by the color of the icon. The future path of the vehicle as provided by the ground clearance command entered via the controllers microphone 35 is shown as a colored line on the display 30. The status of all field lights including each edge light 20_{1-n} in each edge light circuit 18_{1-n} is shown via color on the display 30.

Use of object orientated software provides the basis for building a model of an airport. The automatic inheritance feature allows a data structure to be defined once for each object and then replicated automatically for each instance of that object. Automatic flow down assures that elements of the data base are not corrupted due to typing errors. It also assures that the code is regular and structured. Rule based object oriented programming makes it difficult to create unintelligible "spaghetti code." Object oriented programming allows the runways, taxiways, aircraft and sensors, to be decoded directly as objects. Each of these objects contains attributes. Some of these attributes are fixed like runway 22R or flight UA347, and some are variable like vehicle status and position.

In conventional programming we describe the attributes of an object in data structures and then describe the behaviors of the object as procedures that operate on those data structures. Object oriented programming shifts the emphasis and focuses first on the data structure and only secondarily on the procedures. More importantly, object oriented programming allows us to analyze and design programs in a natural manner. We can think in terms of runways and aircraft instead of focusing on either the behavior or the data structures of the runways and aircraft.

Table 1 shows a list of objects with corresponding attributes. Each physical object that is important to the runway incursion problem is modeled. The basic airplane or vehicle tracking algorithm is shown in Table 2 in a Program Design Language (PDL). The algorithm which handles sensor fusion, incursion avoidance and safety alerts is shown in a single program even though it is implemented as distributed system using both the central computer system 12 and the sensor microprocessors 44.

55

TABLE 1

<u>OBJECT</u>	<u>ATTRIBUTE</u>	<u>DESCRIPTION</u>	
5 Sensor	Location	X & Y coordinates of sensor	
	Circuit	AC wiring circuit name & number	
	Unique_address	Net address for this sensor and its mate	
	Lamp_intensity	0% to 100% in 0.5% steps	
	10 Strobe_status	Strobe_status	Blink rate/off
		Strobe-delay	From start signal
		Sensor_status	Detect/no detect
15 Runway	Sensor_type	IR, laser, proximity, etc.	
	Name	22R, 27, 33L, etc.	
	Location	X & Y coordinates of start of center line	
	Length	In feet	
	Width	In feet	
	20 Direction	Direction	In degrees from north
		Status	Not_active, active_takeoff, active_landing, alarm
Sensors (MV)		List of lights/sensors along this runway	
25 Intersections (MV)	Intersections (MV)	List of intersections	
	Vehicles	List of vehicles on the runway	
	Taxiway	Name	Name of taxiway
Location		X & Y coordinates of start of center line	
Length		In feet	
Width		In feet	
Direction		In degrees from north	
Status		Not active, active, alarm	
Sensors (MV)		List of intersections	
35 Hold_Locations	Hold_Locations	List of holding locations	
	Vehicles (MV)	List of vehicles on the runway	

40

45

50

55

EP 0 613 109 A1

5	Intersection	Name	Intersection Name
		Location	Intersection of two center lines
		Status	Vacant/Occupied
		Sensors (MV)	List of sensors creating intersection border
10 15 20	Aircraft	Airline	United
		Model	727-200
		Tail-number	N3274Z
		Empty_weight	9.5 tons
		Freight_weight	2.3 tons
		Fuel_weight	3.2 tons
		Top_speed	598 mph
		V1_speed	100 mph
		V2_speed	140 mph
	Acceleration	0.23 g's	
	Deceleration	0.34 g's	

MV = Multi-variable or array

25

Table 2

```

while (forever)
  | if (edge light shows a detection)
  | | if (adjacent light also shows a detection sensor fusion)
  | | | /* CONFIRMED DETECTION */
  | | | if (previous block showed a detection)
  | | | | /* ACCEPT HANDOFF */
  | | | | Update aircraft position and speed
  | | | else
  | | | | /* MAY BE AN ANIMAL OR SERVICE TRUCK */
  | | | | Alert operator to possible incursion
  | | | | /* MAY BE AN AIRCRAFT ENTERING THE SYSTEM */
  | | | | Start a new track
  | | else
  | | | Request status from adjacent light

```

55

```

| | | if (Adjacent light is OK)
| | | | /* NON CONFIRMED DETECTION */
5 | | | else
| | | | Flag adjacent light for repair
| | | endif
10 | | endif
| endif
| if (Edge light loses a detection AND status is OK)
15 | | if (Next block showed a detection)
| | | /* PROPER HANDOFF */
| | | else
20 | | | if (vehicle speed > = takeoff)
| | | | Handoff to departure control
| | | else
25 | | | | /* MISSING HANDOFF */
| | | | Alert operator to possible incursion
| | | endif
| | endif
30 | endif
| /* CHECK FOR POSSIBLE COLLISIONS */
| for (all tracked aircraft)
35 | | Plot future position
| | if (position conflict)
| | | Alert operator to possible incursion
40 | | endif
| endif
| Update display
45 | endwhile

```

Referring again to FIG. 1 and FIG. 2, the control of taxiway lighting intensity is usually done by placing all the lights on the same series circuit and then regulating the current in that circuit. In the present embodiment the intensity of the lamp 40 is controlled by sending a message with the light intensity value to the microprocessor 44 located within the light assembly 20_{1-n}. The message allows for intensity settings in the range of 0 to 100% in 0.5% steps. The use of photocell 46 to check the light output allows a return message to be sent if the bulb does not respond. This in turn generates a maintenance report on the light. The strobe light 48 provides an additional optional capability under program control of the microprocessor 44. Each of the microprocessors 44 in the edge light assemblies 20 is individually addressable. This means every lamp on the field is controlled individually by the central computer system 12.

The system 10 can be programmed to provide an Active Runway Indicator by using the strobe lights 48 in those edge light assemblies 20_{1-n} located on the runway 64 to continue the approach light "rabbit" strobe

pattern all the way down the runway. This lighting pattern could be turned-on as a plane is cleared for landing and then turned-off after the aircraft has touched down. A pilot approaching the runway along an intersecting taxiway would be alerted in a clear and unambiguous way that the runway was active and should not be crossed.

5 If an incursion was detected the main computers 26, 28 could switch the runway strobe lights 48 from the "rabbit" pattern to a pattern that alternatively flashes either side of the runway in a wig-wag fashion. A switch to this pattern would be interpreted by the pilot of an arriving aircraft as a wave off and a signal to go around. The abrupt switch in the pattern of the strobes would be instantaneously picked up by the air crew in time for them to initiate an aborted landing procedure.

10 During Category III weather conditions both runway and taxiway visibility are very low. Currently radio based landing systems are used to get the aircraft from final approach to the runway. Once on the runway it is not always obvious which taxiways are to be used to reach the airport terminal. In system 10 the main computers 26,28 can control the taxiway lamps 40 as the means for guiding aircraft on the ground during CAT III conditions. Since the intensity of the taxiway lamps 40 can be controlled remotely, the lamps just in front of an aircraft could be intensified or flashed as a means of guiding it to the terminal.

15 Alternatively, a short sequence of the "rabbit" pattern may be programmed into the taxiway strobes just in front of the aircraft. At intersections, either the unwanted paths may have their lamps turned off or the entrance to the proper section of taxiway may flash directing the pilot to head in that direction. Of course in a smart system only those lights directly in front of a plane would be controlled, all other lamps on the field would remain in their normal mode.

20 Referring now to FIG. 9, a block diagram is shown of the data flow within the system 10 (as shown in FIG. 1 and FIG. 5). The software modules are shown that are used to process the data within the computers 26, 28 of the central computer system 12. The tracking of aircraft and other vehicles on the airport operates under the control of a sensor fusion software module 101 which resides in the computers 26, 28. The sensor fusion software module 101 receives data from the plurality of sensors 50, a sensor 50 being located in each edge light assembly 20_{1-n}, which reports the heat level detected, and this software module 101 combines this information through the use of rule based artificial intelligence to create a complete picture of all ground traffic at the airport on a display 30 of the central computer system 12.

25 The tracking algorithm starts a track upon the first report of a sensor 50 detecting a heat level that is above the ambient background level of radiation. This detection is then verified by checking the heat level reported by the sensor directly across the pavement from the first reporting sensor. This secondary reading is used to confirm the vehicle detected and to eliminate false alarms. After a vehicle has been confirmed the sensors adjacent to the first reporting sensor are queried for changes in their detected heat level. As soon as one of the adjacent sensors detects a rise in heat level a direction vector for the vehicle can be established. This process continues as the vehicle is handed off from sensor to sensor in a bucket brigade fashion as shown in FIG. 7. Vehicle speed can be roughly determined by calculating the time between vehicle detection by adjacent sensors. This information is combined with information from a system data base on the location of each sensor to calculate the velocity of the target. Due to hot exhaust or jet blast, the sensors behind the vehicle may not return to a background level immediately. Because of these condition, the algorithm only uses the first four sensors (two on either side of the taxiway) to calculate the vehicles position. The vehicle is always assumed to be on the centerline of the pavement and between the first four reporting sensors.

30 Vehicle identification can be added to the track either manually or automatically by an automated source that can identify a vehicle by its position. An example would be prior knowledge of the next aircraft to land on a particular runway. Tracks are ended when a vehicle leaves the detection system. This can occur in one of two ways. The first way is that the vehicle leaves the area covered by the sensors 50. This is determined by a vehicle track moving in the direction of a gateway sensor and then a lack of detection after the gateway sensor has lost contact. A second way to leave the detection system is for a track to be lost in the middle of a sensor array. This can occur when an aircraft departs or a vehicle runs onto the grass. Takeoff scenarios can be determined by calculating the speed of the vehicle just before detection was lost. If the vehicle speed was increasing and above rotation speed then the aircraft is assumed to have taken off. If not then the vehicle is assumed to have gone on to the grass and an alarm is sounded.

35 Referring to FIG. 5 and FIG. 9, the ground clearance routing function is performed by the speech recognition unit 33 along with the ground clearance compliance verifier software module 103 running on the computers 26,28. This software module 103 comprises a vehicle identification routine, clearance path routing, clearance checking routine and a path checking routine.

40 The vehicle identification routine is used to receive the airline name and flight number (i.e. "Delta 374") from the speech recognition unit 33 and it highlights the icon of that aircraft on the graphic display of the airport on display 30.

The clearance path routine takes the remainder of the controller's phrase (i.e. "outer taxiway to echo, hold short of runway 15 Left") and provides a graphical display of the clearance on the display 30 showing the airport.

The clearance checking routine checks the clearance path for possible conflict with other clearances and vehicles. If a conflict is found the portion of the path that would cause an incursion is highlighted in a blinking red and an audible indication is given to the controller via speaker 32.

The path checking routine checks the actual path of the vehicle as detected by the sensors 50 after the clearance path has been entered into the computers 26, 28 and it monitors the actual path for any deviation. If this routine detects that a vehicle has strayed from the assigned course, the vehicle icon on the graphic display of the airport flashes and an audible indicator is given to the controller via speaker 32 and optionally the vehicle operator via radio 37.

The airport vehicle incursion avoidance system 10 operates under the control of safety logic routines which reside in the collision detection software module 104 running on computers 26, 28. The safety logic routines receive data from the sensor fusion software module 101 location program via the tracker software module 102 and interpret this information through the use of rule based artificial intelligence to predict possible collisions or runway incursions. This information is then used by the central computer system 12 to alert tower controllers, aircraft pilots and truck operators to the possibility of a runway incursion. The tower controllers are alerted by the display 30 along with a computer synthesized voice message via speaker 32. Ground traffic is alerted by a combination of traffic lights, flashing lights, stop bars and other alert lights 34, lamps 40 and 48, and computer generated voice commands broadcast via radio 36.

Knowledge based problems are also called fuzzy problems and their solutions depend upon both program logic and an interface engine that can dynamically create a decision tree, selecting which heuristics are most appropriate for the specific case being considered. Rule based systems broaden the scope of possible applications. They allow designers to incorporate judgement and experience, and to take a consistent solution approach across an entire problem set.

The programming of the rule based incursion detections software is very straight forward. The rules are written in English allowing the experts, in this case the tower personnel and the pilots, to review the system at an understandable level. Another feature of the rule based system is that the rules stand alone. They can be added, deleted or modified without affecting the rest of the code. This is almost impossible to do with code that is created from scratch. An example of a rule we might use is:

```
30   If (Runway_Status = Active)
       then (Stop_Bar_Lights = RED).
```

This is a very simple and straight forward rule. It stands alone requiring no extra knowledge except how Runway_Status is created. So let's make some rules affecting Runway_Status.

```
35   If (Departure = APPROVED) or (Landing = IMMINENT),
       then (Runway_Status = ACTIVE).
```

For incursion detection, another rule is:

```
   If (Runway_Status = ACTIVE) and (Intersection = OCCUPIED),
       then (Runway_Incursion = TRUE).
```

Next, detect that an intersection of a runway and taxiway are occupied by the rules:

```
40   If (Intersection_Sensors = DETECT),
       then (Intersection = OCCUPIED).
```

To predict that an aircraft will run a Hold Position stop, the following rule is created:

```
   If (Aircraft_Stopping_Distance > Distance_to_Hold_Position),
       then (Intersection = OCCUPIED).
```

45 In order to show that rules can be added without affecting the reset of the program, assume that after a demonstration of the system 10 to tower controllers, they decided that they wanted a "Panic Button" in the tower to override the rule based software in case they spot a safety violation on the ground. Besides installing the button, the only other change would be to add this extra rule.

```
50   If (Panic_button = PRESSED),
       then (Runway_Incursion = TRUE).
```

It is readily seen that the central rule based computer program is very straight forward to create, understand and modify. As types of incursions are defined, the system 10 can be upgraded by adding more rules.

Referring again to FIG. 9, the block diagram shows the data flow between the functional elements within the system 10 (FIG. 1). Vehicles are detected by the sensor 50 in each of the edge light assemblies 20_{1-n}. This information is passed over the local operating network (LON) via edge light wiring 21_{1-n} to the LON bridges 22_{1-n}. The individual message packets are then passed to the redundant computers 26 and 28 over the wide area network (WAN) 14 to the WAN interface 108. After arriving at the redundant computers 26 and 28, the message packet is checked and verified by a message parser software module 100. The contents of the mes-

sage are then sent to the sensor fusion software module 101. The sensor fusion software module 101 is used to keep track of the status of all the sensors 50 on the airport; it filters and verifies the data from the airport and stores a representative picture of the sensor array in a memory. This information is used directly by the display 30 to show which sensors 50 are responding and used by the tracker software module 102. The tracker software module 102 uses the sensor status information to determine which sensor 50 reports correspond to actual vehicles. In addition, as the sensor reports and status change, the tracker software module 102 identifies movement of the vehicles and produces a target location and direction output. This information is used by the display 30 in order to display the appropriate vehicle icon on the screen.

The location and direction of the vehicle is also used by the collision detection software module 104. This module checks all of the vehicles on the ground and plots their expected course. If any two targets are on intersecting paths, this software module generates operator alerts by using the display 30, the alert lights 34, the speech synthesis unit 29 coupled to the associated speaker 32, and the speech synthesis unit 31 coupled to radio 37 which is coupled to antenna 39.

Still referring to FIG. 9, another user of target location and position data is the ground clearance compliance verifier software module 103. This software module 103 receives the ground clearance commands from the controller's microphone 35 via the speech recognition unit 33. Once the cleared route has been determined, it is stored in the ground clearance compliance verifier software module 103 and used for comparison to the actual route taken by the vehicle. If the information received from the tracker software module 102 shows that the vehicle has deviated from its assigned course, this software module 103 generates operator alerts by using the display 30, the alert lights 34, the speech synthesis unit 29 coupled to speaker 32, and the speech synthesis unit 31 coupled to radio 37 which is coupled to antenna 39.

The keyboard 27 is connected to a keyboard parser software module 109. When a command has been verified by the keyboard parser software module 109, it is used to change display 30 options and to reconfigure the sensors and network parameters. A network configuration data base 106 is updated with these reconfiguration commands. This information is then turned into LON message packets by the command message generator 107 and sent to the edge light assemblies 20_{1-n} via the WAN interface 108 and the LON bridges 22_{1-n}.

Referring now to FIG. 1 and FIG. 10, FIG. 10 shows a pictorial diagram of an infrared vehicle identification system 109 invention comprising an infrared (IR) transmitter 112 mounted on an airplane 110 wheel strut 111 and an IR receiver 128 which comprises a plurality of edge light assemblies 20_{1-n} of an airport lighting system also shown in FIG. 1. The combination of the IR transmitter 112 mounted on aircraft and/or other vehicles and a plurality of IR receivers 128 located along runways and taxiways form the infrared vehicle identification system 109 for use at airports for the safety, guidance and control of surface vehicles in order to provide positive detection and identification of all aircraft and other vehicles and to prevent runway incursions. Runway incursions generally occur when aircraft or other vehicles get onto a runway and conflict with aircraft cleared to land or takeoff on that same runway. All such incursions are caused by human error.

Referring now to FIG. 11, a block diagram of the IR transmitter 112 is shown comprising an embedded microprocessor 118 having DC power 114 inputs from the aircraft host or vehicle on which the IR transmitter 112 is mounted and an ID switch 116 within the aircraft for entering vehicle identification data which is received by the IR transmitter 112 on a serial line. Vehicle position information is provided to the IR transmitter 112 from a vehicle position receiver 117 which may be embodied by a global positioning system (GPS) receiver readily known in the art. The output of embedded microprocessor 118 feeds an IR emitter comprising a light emitting diode (LED) array 120. When power is applied to the IR transmitter 112, the microprocessor continuously outputs a coded data stream 121 (FIG. 13) which is transmitted by the IR LED array 120. The embedded microprocessor 118 may be embodied by microprocessor Model MC 6803 or equivalent manufactured by Motorola Microprocessor Products of Austin; Texas. The IR LED array 120 may be embodied by IR LED Devices manufactured by Harris Semiconductor of Melbourne, Florida.

Referring now to FIG. 12, a top view of the IR transmitter 112 comprising the IR LED array 120 mounted on an airplane wheel strut 111 is shown. The IR LED array 120 comprises a plurality of high power LEDs each having a beam width of 15°. By placing thirteen LEDs in an array, a 195° area can be covered. The IR LED array 120 illuminates edge light assemblies 20₁₋₄ along the edges of the runway 64. Each of the edge light assemblies 20₁₋₄ comprises an IR receiver 128.

Referring now to FIG. 13, the coded data stream emitted from the IR transmitter 112 comprises six separate fields. The first field is called timing pattern 122 and comprises a set of equally spaced pulses. The second field is called unique word 123 which marks the beginning of a message. The third field is called character count 124 which specifies the number of characters in a message. The fourth field is called vehicle identification number 125. The fifth field is called vehicle position 126 and provides latitude and longitude information.

The sixth field is called message checksum 127. The equally spaced pulses of the timing pattern 122 allow the IR receiver 128 to calculate the baud rate of a transmitted message and automatically adjust its internal timing to compensate for either a doppler shift or an offset in clock frequency. The checksum 126 field allows the IR receiver 128 to find the byte boundary. The character count 124 field is used to alert the IR receiver 128 in the edge light assemblies 20₁₋₄ as to the length of the message being received. The IR receiver 128 uses this field to determine when the message has ended and if the message was truncated.

The vehicle identification number 125 field comprises an airline flight number or a tail number of an aircraft or a license number of other vehicles. The actual number can be alpha-numeric since each character will be allocated eight (8) bits. An ASCII code which is known to those of ordinary skill in the art is an example of a code type that may be used. The only constraints on the vehicle ID number is that it be unique to the vehicle and that it be entered in the airport's central computer data base to facilitate automatic identification. The checksum 127 guarantees that a complete and correct message is received. If the message is interrupted for any reason, such as a blocked beam or a change in vehicle direction, it is instantly detected and the reception voided. This procedure reduces the number of false detects and guarantees that only perfect vehicle identification messages are passed on to the central computer system 12 at the airport tower.

Referring now to FIG. 1, FIG. 2, FIG. 10 and FIG. 14, a block diagram of the IR receiver 128 is shown in FIG. 14 which comprises an IR sensor 130 connected to an edge light assembly 20_{1-n} shown in FIG. 1, FIG. 2 and FIG. 10, on an airport. In FIG. 14, only the relevant portions of FIG. 2 are shown, but it should be understood that all of the elements of the edge light assembly 20_{1-n} shown in FIG. 2 are considered present in FIG. 14. The IR receiver 128 comprises the IR sensor 130 which receives the coded data stream 121 (FIG. 13) from the transmitter 112. The output of the IR sensor 130 is fed to the microprocessor 44 for processing by an IR message routine 136 for detecting the data message. A vehicle sensor routine 138 in microprocessor 44 processes signals from the vehicle sensor 50 for detecting an aircraft or other vehicles. The IR message routine 136 is implemented with software within the microprocessor 44 as shown in the flow chart of FIG. 15. The vehicle sensor routine 138 is also implemented with software within the microprocessor 44 as shown in the flow chart of FIG. 16. The outputs of the IR message routine 136 and vehicle sensor routine 138 are processed by the microprocessor 44 which sends via the power line modem 54 the identified aircraft or vehicle and their position data over the edge light wiring 21_{1-n} communication lines to the central computer system 12 shown in FIG. 1 at the airport terminal or control tower. The IR sensor 130 may be embodied with Model RY5BD01 IR sensor manufactured by Sharp Electronics, of Paramus, New Jersey. The microprocessor 44 may be embodied by the VLSI Neuron[®] Chip, manufactured by Echelon Corporation, of Palo Alto, California.

Referring to FIG. 15, a flow chart of the IR message routine 136 is shown which is a communication protocol continuously performed in the microprocessor 44 of the IR receiver 128. After an IR signal is detected 150 the next action is transmitter acquisition or to acquire timing 152. The microprocessor 44 looks for the proper timing relationship between the received IR pulses. If the correct on/off ratio exists, the microprocessor 44 calculates the baud rate from the received timing and waits to acquire the unique word 156 signifying byte boundary and then checks for the capture of the character count 160 field byte. After the character count is known, the microprocessor 44 then captures each character in the vehicle ID 162 field and stores them away in a buffer. It then captures vehicle position 163 including latitude and longitude data. If the IR coded data stream is disrupted before all the vehicle ID characters are received, the microprocessor 44 aborts this reception try and returns to the acquisition or IR detected 150 state. After all characters have been received, the checksum 164 is calculated. If the checksum matches 166, then the message is validated and the vehicle ID relayed 168 to the central computer system 12. With this scheme the microprocessor 44 is implementing both the physical and a link layer of the OSI protocol by providing an error free channel.

Referring now to FIG. 16, a flow chart is shown of the vehicle sensor routine 138 software running on microprocessor 44. This software routine 138 runs as a continuous loop. An internal timer is continuously checked for a time out condition (timer = zero 170). As soon as the timer expires the analog value from sensor 50 is read (Read Sensor Value 171) by the microprocessor 44 and the timer is reset to the poll_time 172 variable downloaded by the central computer system 12. This sensor value is compared against a predetermined detection threshold 173 and downloaded by the central computer system 12. If the sensor value is less than the detection threshold, the microprocessor 44 sets the network variable prelim_detect to the FALSE state 174. If the sensor value is greater than the detection threshold the microprocessor 44 sets the network variable prelim_detect to the TRUE state 175. If a preliminary detection is declared, the program then checks to see what reporting mode 176 is in use. If all detections are required to be sent to the central computer system 12, then this sensor value 180 is sent. If only those readings that are different from the previous reading by a predetermined delta and download by the central computer system 12, then this check is made 177. If the change is greater than the delta 177, the program checks to see if it should confirm the detection 178 to eliminate any

false alarms. If a confirmation is not required, then this sensor value 181 is sent. If in the confirmation mode, then the adjacent sensor's 179 preliminary network variable is checked. If the adjacent sensor has also detected the object, then the current sensor value 182 is sent.

This concludes the description of the preferred embodiment. However, many modifications and alterations will be obvious to one of ordinary skill in the art without departing from the spirit and scope of the inventive concept. Therefore, it is intended that the scope of this invention be limited only by the appended claims.

Claims

1. A vehicle identification system for identifying aircraft and other vehicles on surface pathways including runways and other areas of an airport comprising:
 - means disposed on said aircraft and other vehicles for transmitting identification message data;
 - means disposed in each of a plurality of light assembly means on said airport for receiving and decoding said message data from said transmitting means;
 - means for providing power to each of said plurality of light assembly means;
 - means for processing said decoded identification message data generated by said receiving and decoding means in each of said plurality of light assembly means;
 - means for providing data communication between each of said light assembly means and said processing means; and
 - said processing means comprises means for providing a graphic display of said airport comprising symbols representing said aircraft and other vehicles, each of said symbols having said identification message data displayed.
2. The vehicle identification system as recited in Claim 1 wherein said transmitting means comprises:
 - means for creating a unique message data which includes aircraft and flight identification; and
 - infrared means coupled to said message creating means for transmitting a coded stream of said message data.
3. The vehicle identification system as recited in Claim 3 wherein:
 - said message data further includes position information.
4. The vehicle identification system as recited in Claim 1 wherein:
 - said receiving and decoding means comprises an infrared sensor.
5. The vehicle identification system as recited in Claim 3 wherein:
 - said receiving and decoding means comprises microprocessor means coupled to said infrared sensor for decoding said message data.
6. The vehicle identification system as recited in Claim 1 wherein:
 - said plurality of light assembly means being arranged in two parallel rows along runways and taxiways of said airport.
7. The vehicle identification system as recited in Claim 1 wherein said light assembly means comprises:
 - light means coupled to said lines of said power providing means for lighting said airport;
 - vehicle sensing means for detecting aircraft or other vehicles on said airport;
 - microprocessor means coupled to said receiving and decoding means, said light means, said vehicle sensing means and said data communication means for decoding said identification message data; and
 - said data communication means being coupled to said microprocessor means and said lines of said power providing means.
8. The vehicle identification system as recited in Claim 1 wherein:
 - said symbols representing aircraft and other vehicles comprise icons having a shape indicating type of aircraft or vehicle.
9. The vehicle identification system as recited in Claim 1 wherein:
 - said processing means determines a location of said symbols on said graphic display of said airport in accordance with data received from said light assembly means.

10. A vehicle identification system for identifying aircraft and other vehicles on surface pathways including runways and other areas of an airport comprising:
 means disposed on said aircraft and other vehicles for creating a unique message including aircraft and flight identification;
 5 infrared means coupled to said message creating means for transmitting a coded stream of said message data;
 infrared means disposed in each of a plurality of light assembly means on said airport for receiving said message data from said transmitting means;
 microprocessor means coupled to said receiving means for decoding said message data;
 10 means for providing power to each of said plurality of light assembly means;
 means for processing said decoded message data generated by said decoding means in each of said plurality of light assembly means;
 means for providing data communication between each of said light assembly means and said processing means; and
 15 said processing means comprises means for providing a graphic display of said airport comprising symbols representing said aircraft and other vehicles, each of said symbols having said identification message data displayed.
11. The vehicle identification system as recited in Claim 10 wherein:
 20 said message data further includes position information.
12. The vehicle identification system as recited in Claim 10 wherein:
 said plurality of light assembly means being arranged in two parallel rows along runways and taxiways of said airport.
- 25 13. The vehicle identification system as recited in Claim 10 wherein said light assembly means comprises:
 light means coupled to said lines of said power providing means for lighting said airport;
 vehicle sensing means for detecting aircraft or other vehicles on said airport;
 said microprocessor means coupled to said decoding means, said light means, said vehicle sensing means and said data communication means further processes a detection signal from said vehicle sensing means; and
 30 said data communication means being coupled to said microprocessor means and said lines of said power providing means.
14. The vehicle identification system as recited in Claim 10 wherein:
 35 said symbols representing aircraft and other vehicles comprise icons having a shape indicating type of aircraft or vehicle.
15. The vehicle identification system as recited in Claim 10 wherein:
 40 said processing means determines a location of said symbols on said graphic display of said airport in accordance with data received from said light assembly means.
16. A vehicle identification system for surveillance and identification of aircraft and other vehicles on an airport comprising:
 a plurality of light circuits on said airport, each of said light circuits comprises a plurality of light assembly means;
 45 means for providing power to each of said plurality of light circuits and to each of said light assembly means;
 means in each of said light assembly means for sensing ground traffic on said airport;
 means disposed on said aircraft and other vehicles for transmitting identification message data;
 50 means disposed in each of said light assembly means for receiving and decoding said message data from said transmitting means;
 means for processing ground traffic data from said sensing means and decoded message data from each of said light assembly means for presentation on a graphic display of said airport;
 means for providing data communication between each of said light assembly means and said processing means; and
 55 said processing means comprises means for providing such graphic display of said airport comprising symbols representing said ground traffic, each of said symbols having direction, velocity and said identification message data displayed.

17. The vehicle identification system as recited in Claim 16 wherein:
each of said light circuits being located along the edges of taxiways or runways on said airport.
- 5 18. The vehicle identification system as recited in Claim 16 wherein:
said sensing means comprises infrared detectors.
- 10 19. The vehicle identification system as recited in Claim 16 wherein said transmitting means comprises:
means for creating unique message data which includes aircraft and flight identification; and
infrared means coupled to said message creating means for transmitting a coded stream of said
message data.
20. The vehicle identification system as recited in Claim 19 wherein:
said message data further comprises position information.
- 15 21. The vehicle identification system as recited in Claim 16 wherein:
said receiving and decoding means comprises an infrared sensor.
22. The vehicle identification system as recited in Claim 21 wherein:
said receiving and decoding means comprises microprocessor means coupled to said infrared sen-
sor for decoding said message data.
- 20 23. The vehicle identification system as recited in Claim 16 wherein:
said plurality of light assembly means of said light circuits being arranged in two parallel rows along
runways and taxiways of said airport.
- 25 24. The vehicle identification system as recited in Claim 16 wherein said light assembly means comprises:
light means coupled to said lines of said power providing means for lighting said airport;
said ground traffic sensing means for detecting aircraft or other vehicles on said airport;
microprocessor means coupled to said receiving and decoding means, said light means, said
ground traffic sensing means and said data communication means for decoding said identification mes-
sage data and processing a detection signal from said ground traffic sensing means; and
30 said data communication means being coupled to said microprocessor means and said lines of said
power providing means.
- 35 25. The vehicle identification system as recited in Claim 24 wherein:
said light assembly means further comprises a photocell means coupled to said microprocessor
means for detecting the light intensity of said light means.
- 40 26. The vehicle identification system as recited in Claim 24 wherein:
said light assembly means further comprises a strobe light coupled to said microprocessor means.
27. The vehicle identification system as recited in Claim 16 wherein:
said processing means comprises redundant computers for fault tolerance operation.
- 45 28. The vehicle identification system as recited in Claim 16 wherein:
said symbols representing said ground traffic comprise icons having a shape indicating type of air-
craft or vehicle.
- 50 29. The vehicle identification system as recited in Claim 16 wherein:
said processing means determines a location of said symbols on said graphic display of said airport
in accordance with said data receive from said light assembly means.
30. The vehicle identification system as recited in Claim 16 wherein:
said processing means determines a future path of said ground traffic based on a ground clearance
command, said future path being shown on said graphic display.
- 55 31. The vehicle identification system as recited in Claim 16 wherein:
said processing means further comprises means for predicting an airport incursion.
32. The vehicle identification system as recited in Claim 16 wherein said power providing means comprises:

constant current power means for providing a separate line to each of said plurality of light circuits;
and

network bridge means coupled to said constant current power means for providing a communication channel to said processing means for each line of said constant current power means.

- 5
33. A method of providing a vehicle identification system for identifying aircraft and other vehicles on surface pathways including runways and other areas of an airport comprising the steps of:
transmitting identification message data with means disposed on said aircraft and other vehicles;
receiving and decoding said message data from said transmitting means with means disposed in
10 each of a plurality of light assembly means on said airport;
providing power to each of said plurality of light assembly means;
processing said decoded identification message data generated by said receiving and decoding means in each of said plurality of light assembly means;
providing data communication on lines of said power providing means between each of said light
15 assembly means and said processing means; and
providing a graphic display of said airport with said processing means comprising symbols representing said aircraft and other vehicles, each of said symbols having said identification message data displayed.
- 20
34. The method as recited in Claim 33 wherein said step of transmitting identification message data comprises the steps of creating unique message data which includes aircraft and flight identification; and transmitting a coded stream of said message data with infrared means coupled to said message creating means.
- 25
35. The method as recited in Claim 34 wherein said step of transmitting message data further includes transmitting position information.
36. The method as recited in Claim 33 wherein said step of receiving and decoding said message data includes using an infrared sensor.
- 30
37. The method as recited in Claim 33 wherein said step of receiving and decoding said message data further comprises the step of coupling microprocessor means to said infrared sensor for decoding said message data.
- 35
38. The method as recited in Claim 33 wherein said step of receiving and decoding said message data with means disposed in said plurality of light assembly means further comprises the step of arranging said plurality of light assembly means in two parallel rows along runways and taxiways of said airport.
- 40
39. The method as recited in Claim 33 wherein said step of providing a graphic display comprising symbols representing aircraft and other vehicles further comprises the step of providing icons having a shape indicating type of aircraft or vehicle.
- 45
40. The method as recited in Claim 33 wherein said step of providing a graphic display comprises the step of determining a location of said symbols on said graphic display of said airport in accordance with data received from said light assembly means.

50

55

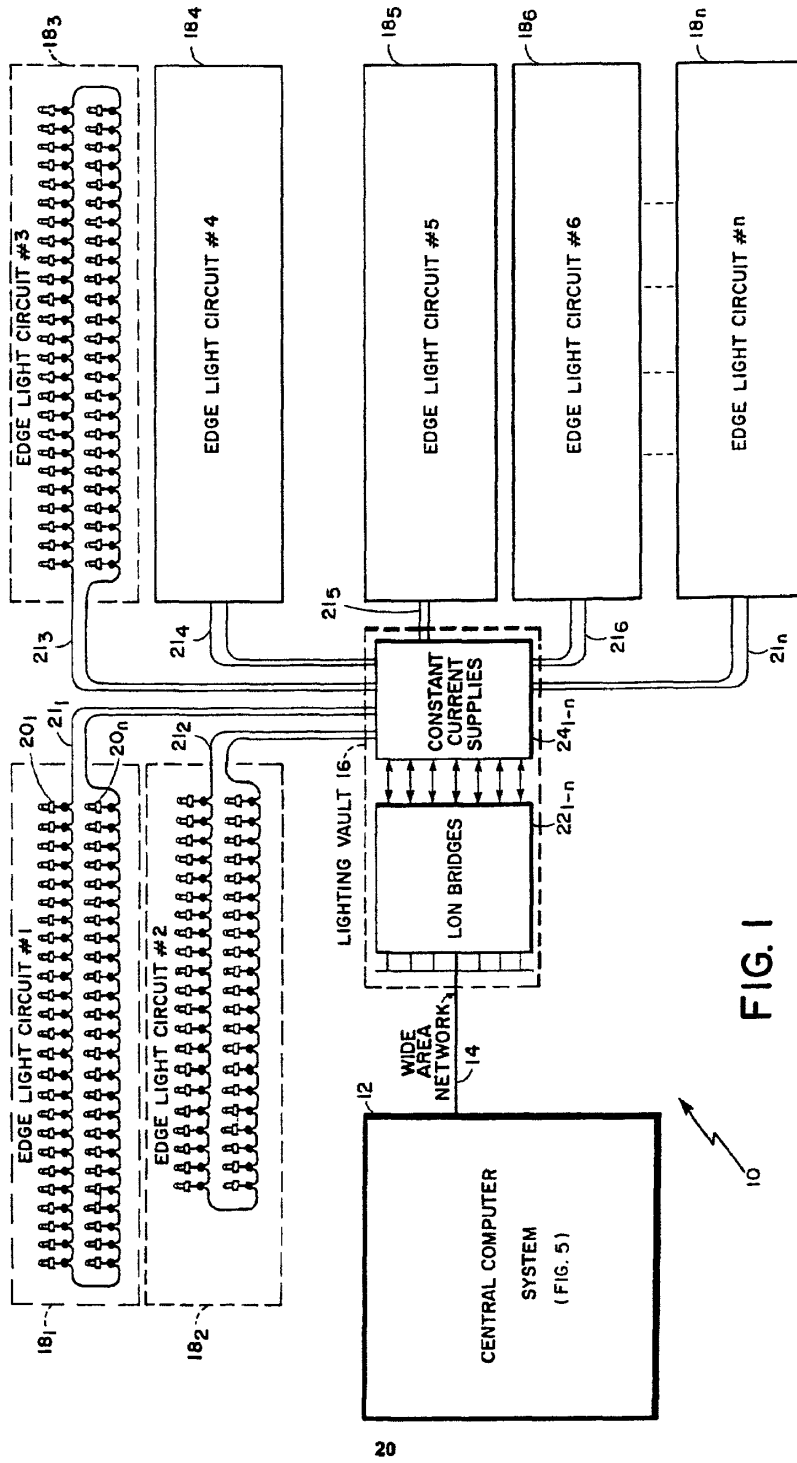

FIG. 1

20

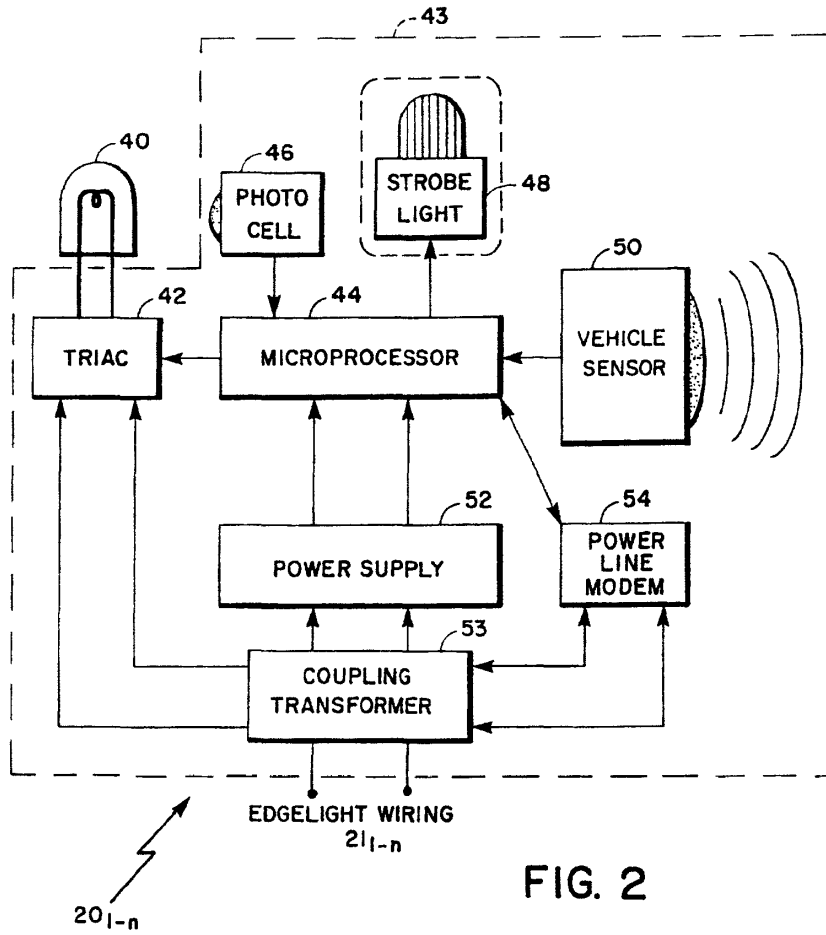

FIG. 2

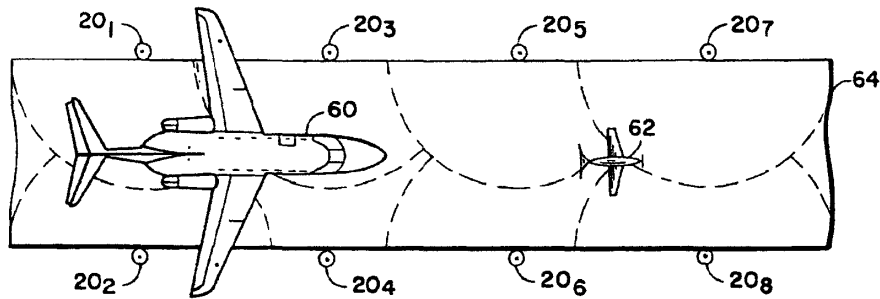

FIG. 4

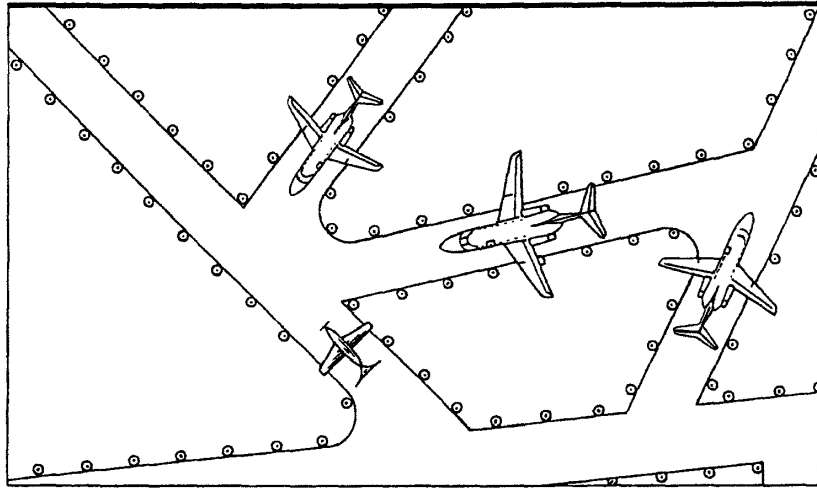

FIG. 8

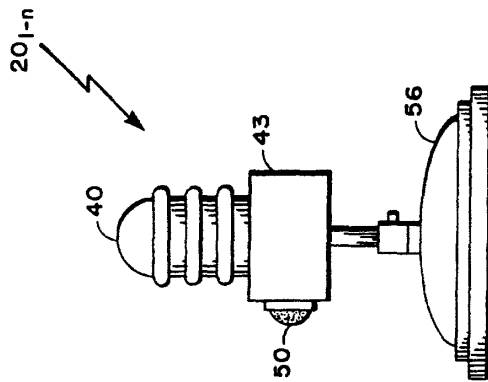

FIG. 3

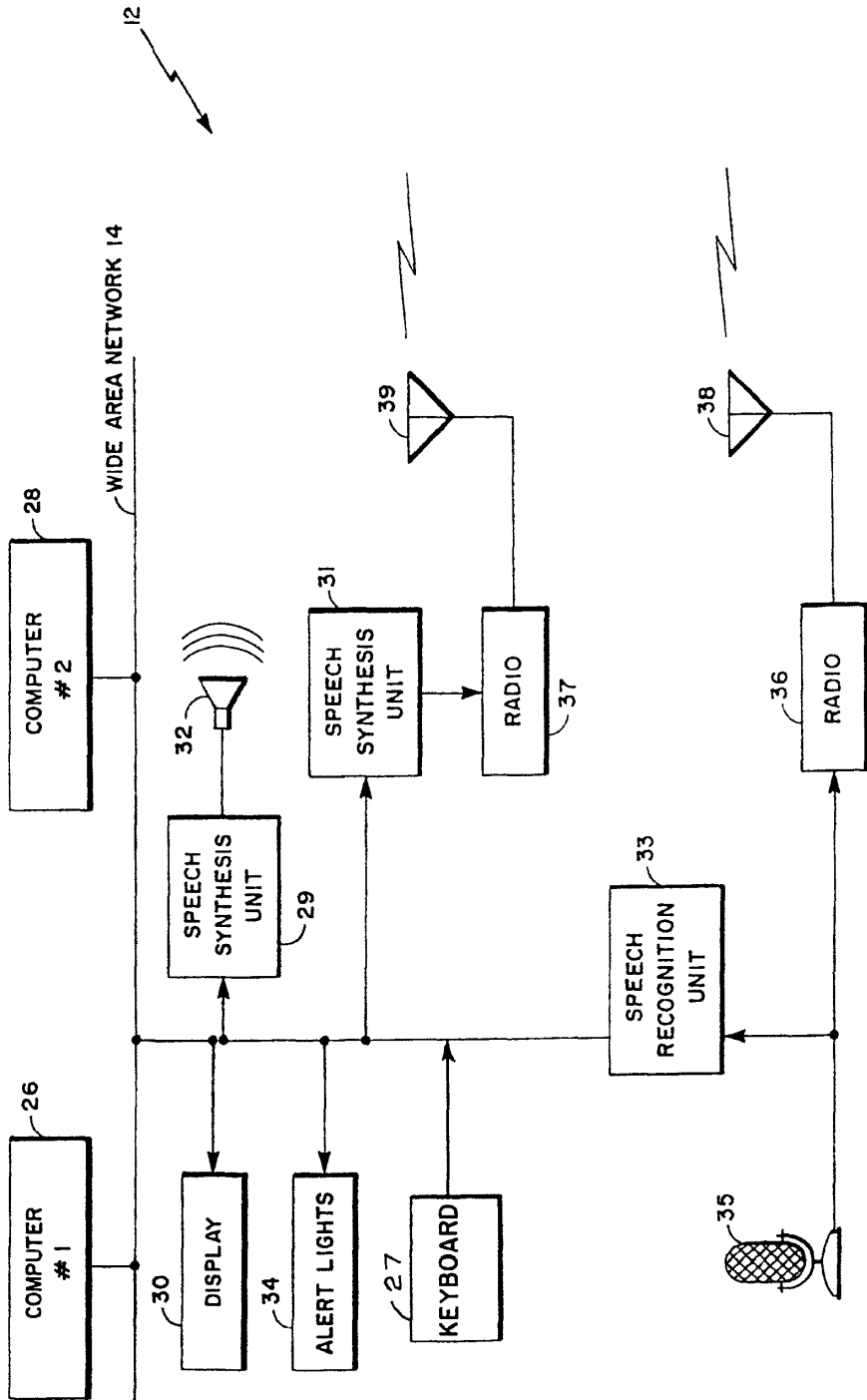

FIG. 5

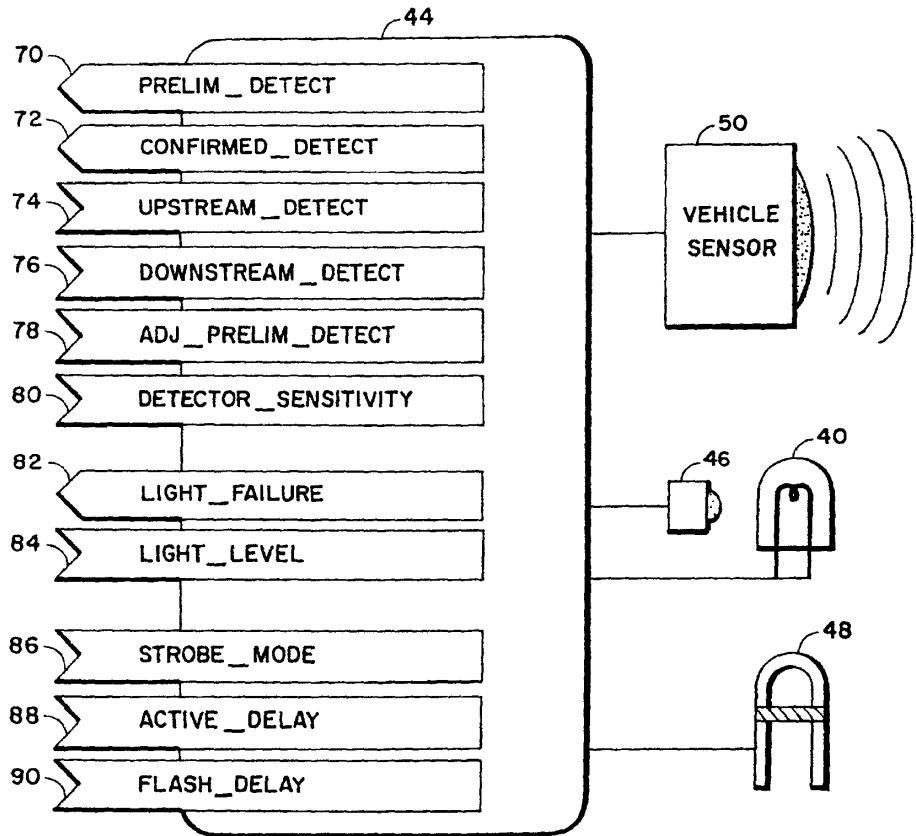

FIG. 6

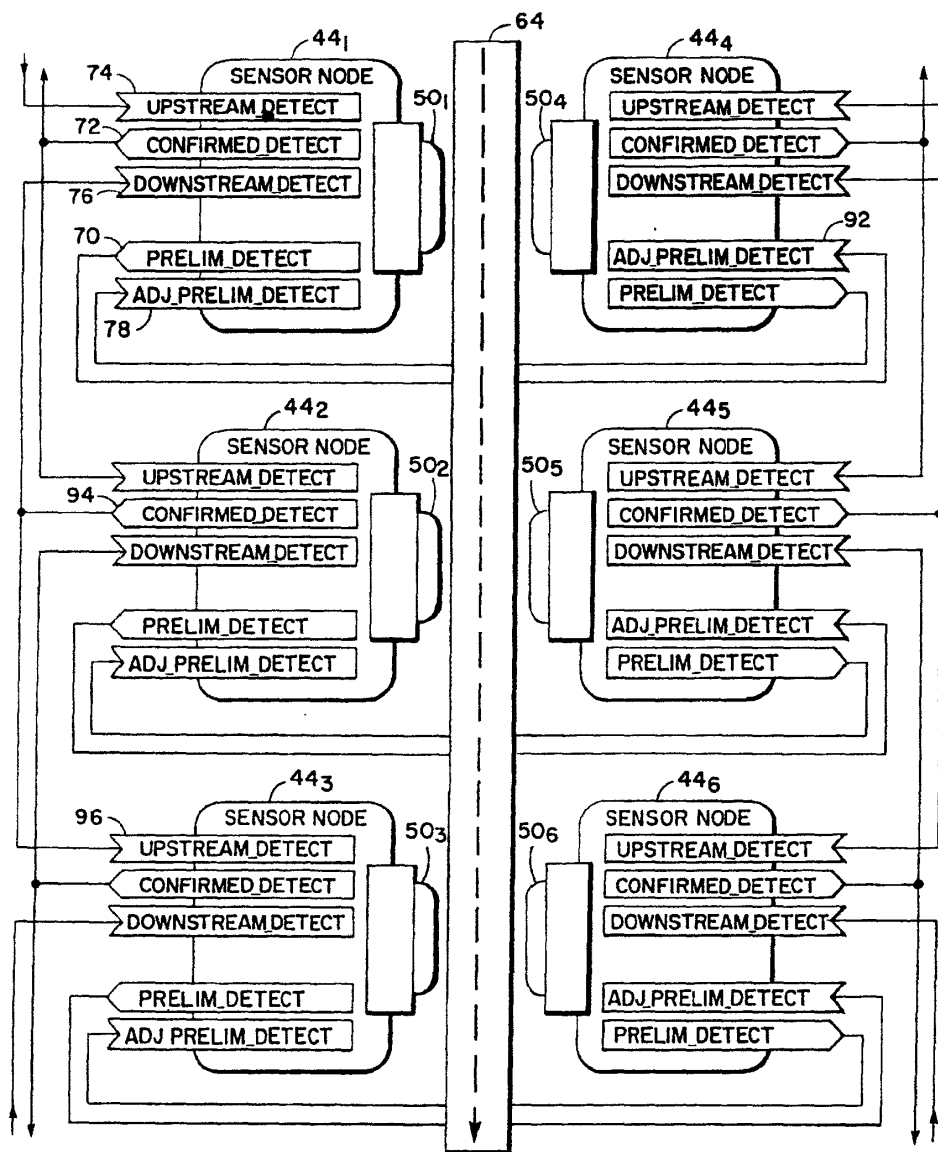

FIG. 7

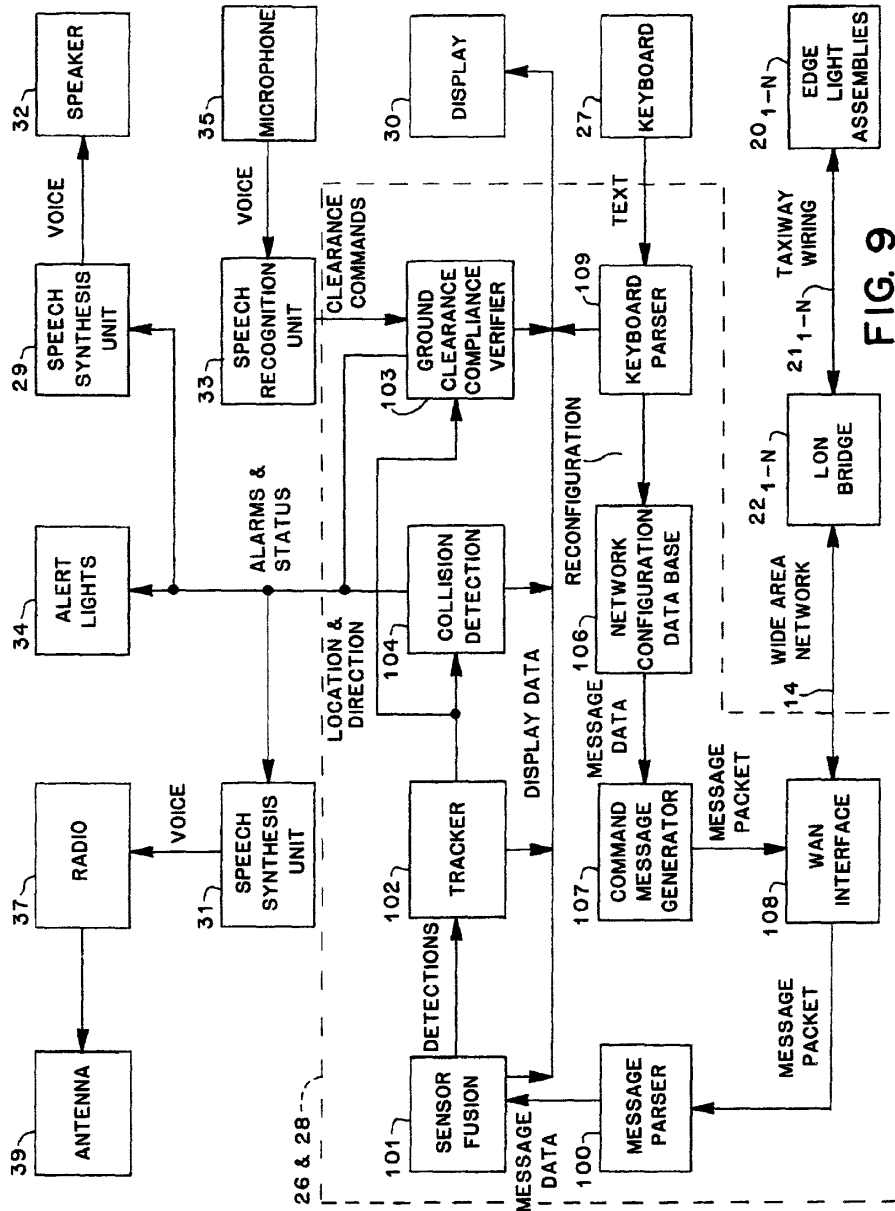

FIG. 9

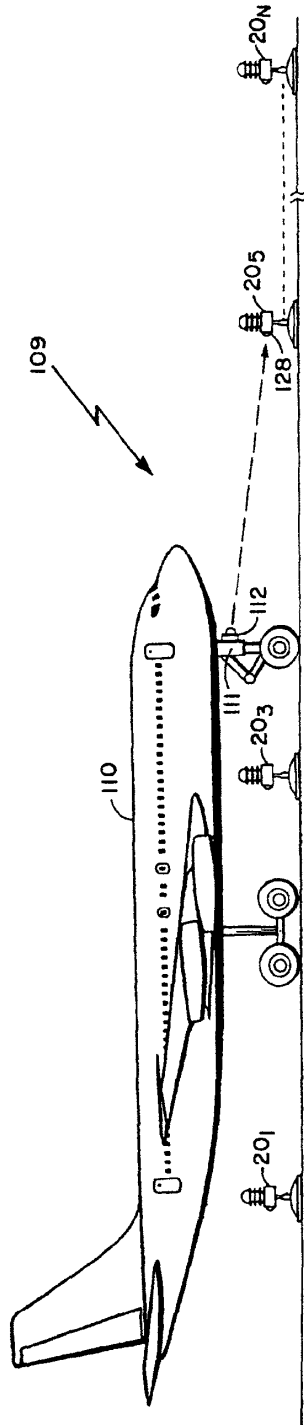

FIG. 10

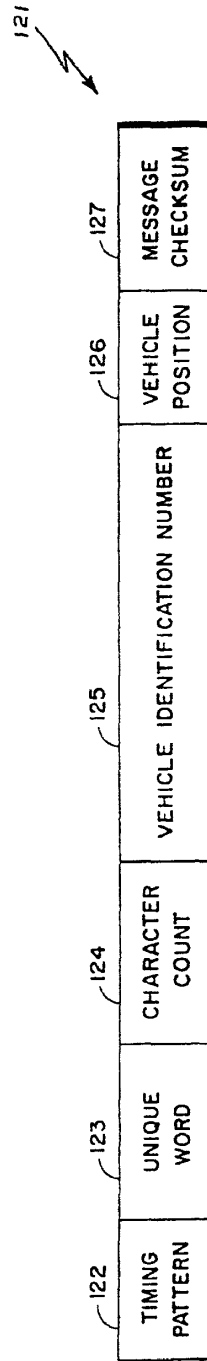

FIG. 13

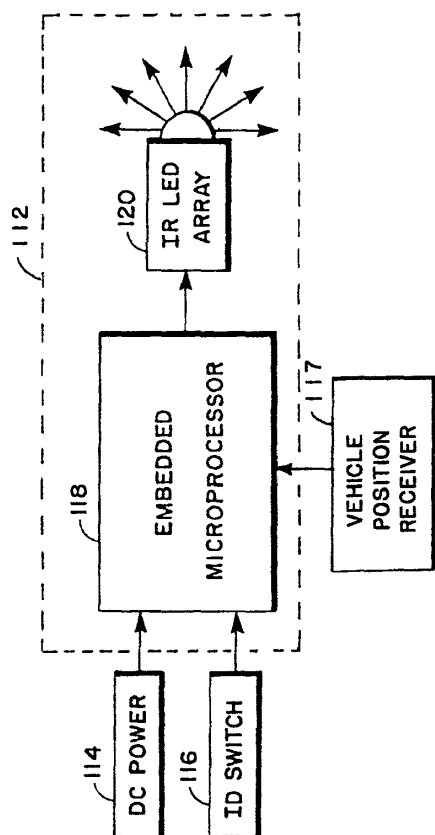

FIG. 11

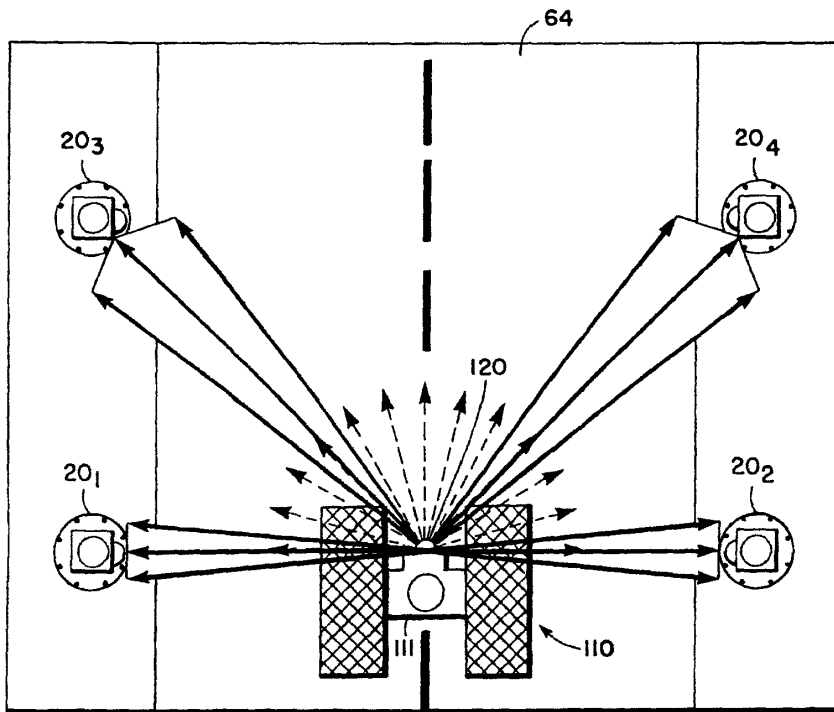

FIG. 12

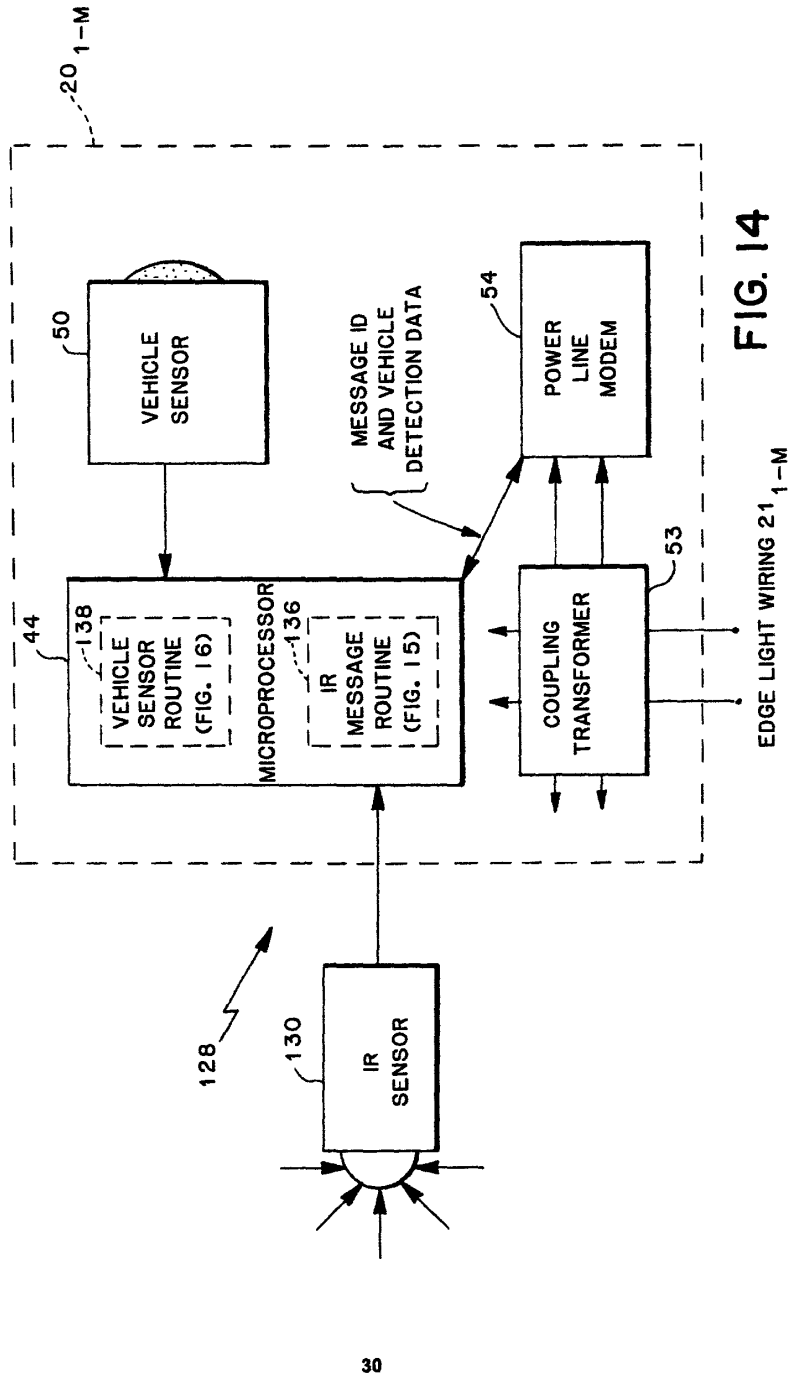

FIG. 14

EDGE LIGHT WIRING 21_{1-M}

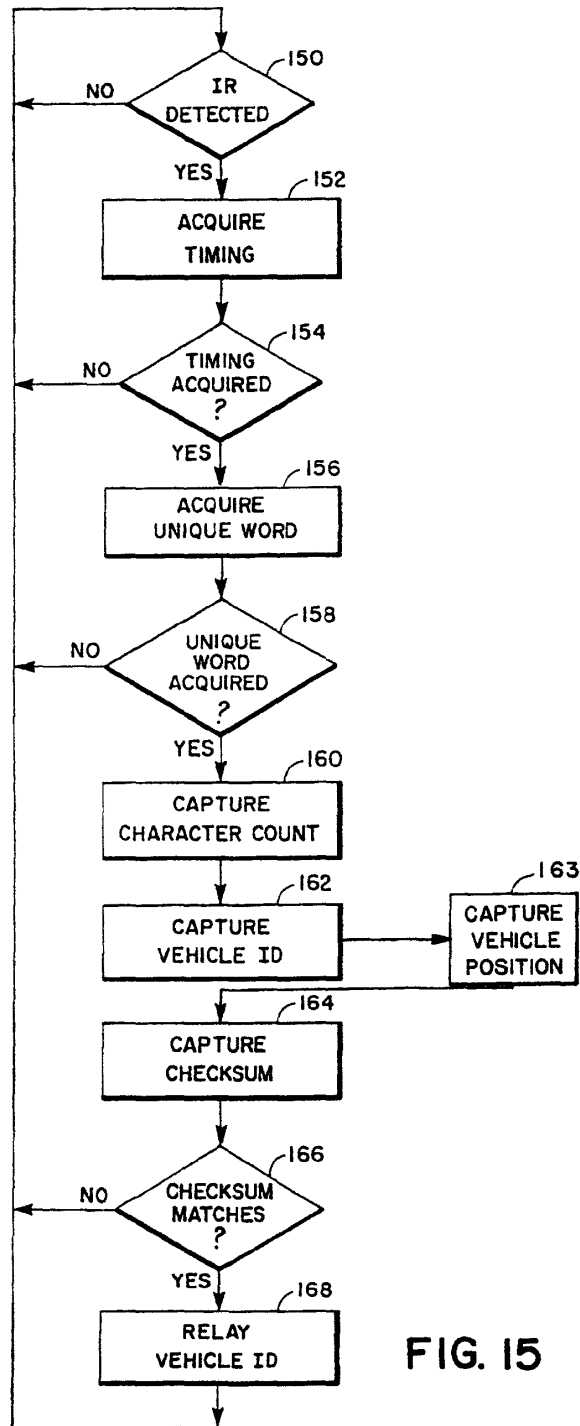

FIG. 15

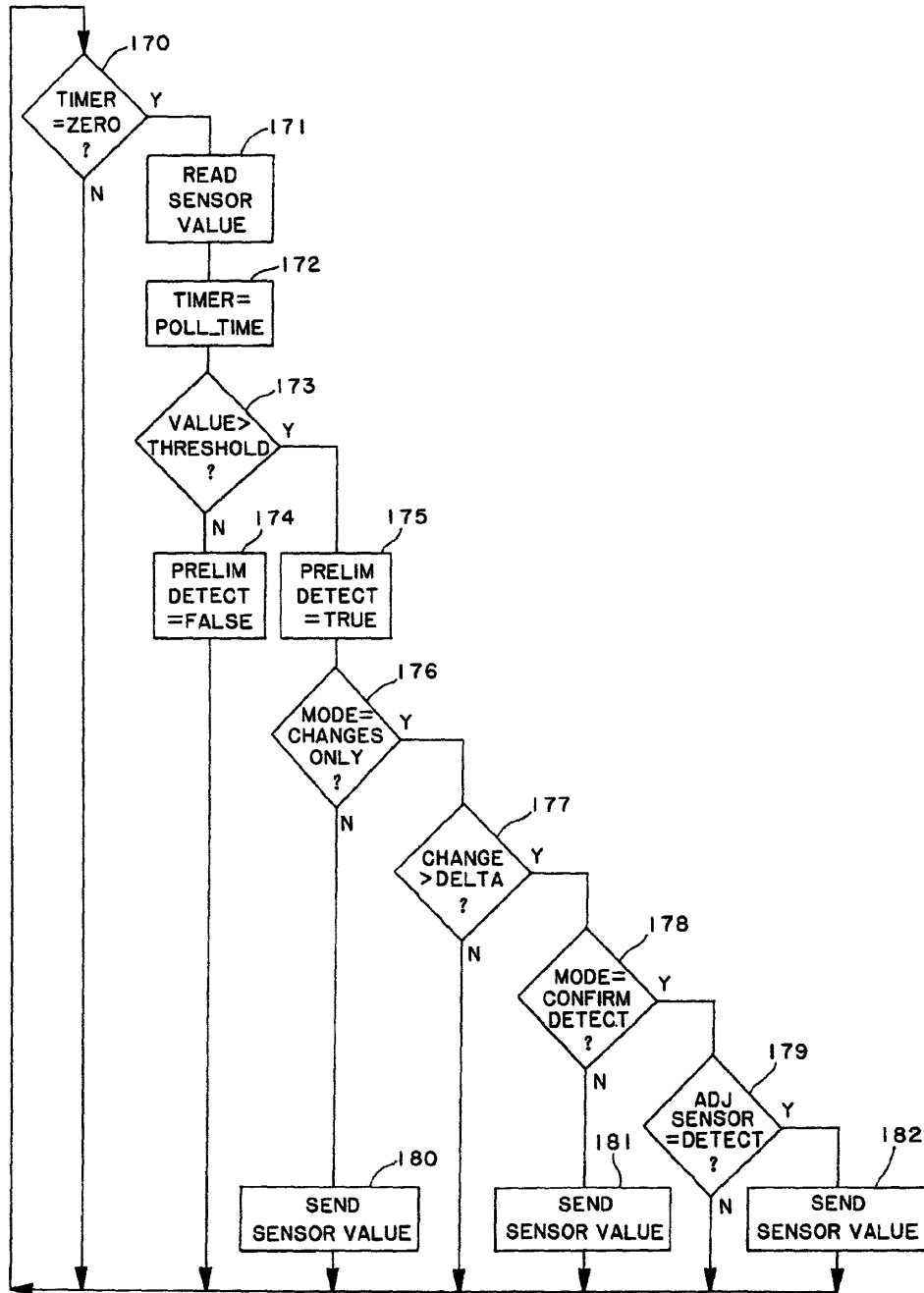

FIG. 16



European Patent Office

EUROPEAN SEARCH REPORT

Application Number
EP 94 30 1261

DOCUMENTS CONSIDERED TO BE RELEVANT			
Category	Citation of document with indication, where appropriate, of relevant passages	Relevant to claim	CLASSIFICATION OF THE APPLICATION (Int.Cl.5)
Y	US-A-3 855 571 (MASSA) * the whole document * ---	1-40	G08G5/06
Y	WO-A-90 04242 (SWEDISH AIRPORT TECHNOLOGY HB) * the whole document * ----	1-40	
Y	FR-A-2 620 551 (RINALDI) * the whole document * ----	2-5, 10, 16, 18, 21, 22, 33, 36, 37	
Y	EP-A-0 209 397 (GENERAL DE INVESTIGACION Y DESARROLLO S.A.) * claims 1,5-13,23,27 * D & US-A-4 845 629 (MURGA ET AL.) ----	7-9, 13-15, 24, 39, 40	
Y	US-A-4 093 937 (HABINGER) * column 2, line 3 - line 33 * ----	26	
Y	US-A-3 706 969 (PAREDES) * column 3, line 18 - column 4, line 59 * * column 22, line 57 - column 23, line 28 * * -----	30, 31	TECHNICAL FIELDS SEARCHED (Int.Cl.5) G08G
The present search report has been drawn up for all claims			
Place of search THE HAGUE		Date of completion of the search 20 June 1994	Examiner Reekmans, M
CATEGORY OF CITED DOCUMENTS X : particularly relevant if taken alone Y : particularly relevant if combined with another document of the same category A : technological background O : non-written disclosure F : intermediate document T : theory or principle underlying the invention E : earlier patent document, but published on, or after the filing date D : document cited in the application L : document cited for other reasons & : member of the same patent family, corresponding document			

EPO FORM 1800/92 (P/0301)

PCT

WORLD INTELLECTUAL PROPERTY ORGANIZATION
International Bureau



INTERNATIONAL APPLICATION PUBLISHED UNDER THE PATENT COOPERATION TREATY (PCT)

<p>(51) International Patent Classification ⁶ : G08G 5/06, B64F 1/00</p>	<p>A1</p>	<p>(11) International Publication Number: WO 96/12265 (43) International Publication Date: 25 April 1996 (25.04.96)</p>
<p>(21) International Application Number: PCT/SE94/00968 (22) International Filing Date: 14 October 1994 (14.10.94) (71) Applicant (for all designated States except US): AIRPORT TECHNOLOGY IN SCANDINAVIA AB [SE/SE]; Frösövägen 3, S-832 01 Frösön (SE). (72) Inventor; and (75) Inventor/Applicant (for US only): MILLGÅRD, Lars [SE/SE]; Bagarvägen 3, S-831 52 Östersund (SE). (74) Agents: ONN, Thorsten et al.; AB Stockholms Patentbyrå, Zacco & Bruhn, P.O. Box 23101, S-104 35 Stockholm (SE).</p>	<p>(81) Designated States: AM, AT, AU, BB, BG, BR, BY, CA, CH, CN, CZ, DE, DK, EE, ES, FI, GB, GE, HU, JP, KE, KG, KP, KR, KZ, LK, LT, LU, LV, MD, MG, MN, MW, NL, NO, NZ, PL, PT, RO, RU, SD, SE, SI, SK, TJ, TT, UA, US, UZ, VN, European patent (AT, BE, CH, DE, DK, ES, FR, GB, GR, IE, IT, LU, MC, NL, PT, SE), OAPI patent (BF, BJ, CF, CG, CI, CM, GA, GN, ML, MR, NE, SN, TD, TG), ARIPO patent (KE, MW, SD, SZ). Published With international search report.</p>	

(54) Title: AIRCRAFT IDENTIFICATION AND DOCKING GUIDANCE SYSTEMS

(57) Abstract

A system for detecting, identifying and docking aircraft using laser pulses to obtain a profile of an object in the distance. The system initially scans the area in front of the gate until it locates and identifies an object. Once the identity of the object is known, the system tracks the object. By using the information from the profile, the system can in real time display the type of airplane, the distance from the stopping point and the lateral position of the airplane.

FOR THE PURPOSES OF INFORMATION ONLY

Codes used to identify States party to the PCT on the front pages of pamphlets publishing international applications under the PCT.

AT	Austria	GB	United Kingdom	MR	Mauritania
AU	Australia	GE	Georgia	MW	Malawi
BB	Barbados	GN	Guinea	NE	Niger
BE	Belgium	GR	Greece	NL	Netherlands
BF	Burkina Faso	HU	Hungary	NO	Norway
BG	Bulgaria	IE	Ireland	NZ	New Zealand
BJ	Benin	IT	Italy	PL	Poland
BR	Brazil	JP	Japan	PT	Portugal
BY	Belarus	KE	Kenya	RO	Romania
CA	Canada	KG	Kyrgyzstan	RU	Russian Federation
CF	Central African Republic	KP	Democratic People's Republic of Korea	SD	Sudan
CG	Congo	KR	Republic of Korea	SE	Sweden
CH	Switzerland	KZ	Kazakhstan	SI	Slovenia
CI	Côte d'Ivoire	LJ	Liechtenstein	SK	Slovakia
CM	Cameroon	LK	Sri Lanka	SN	Senegal
CN	China	LU	Luxembourg	TD	Chad
CS	Czechoslovakia	LV	Latvia	TG	Togo
CZ	Czech Republic	MC	Monaco	TJ	Tajikistan
DE	Germany	MD	Republic of Moldova	TT	Trinidad and Tobago
DK	Denmark	MG	Madagascar	UA	Ukraine
ES	Spain	ML	Mali	US	United States of America
FI	Finland	MN	Mongolia	UZ	Uzbekistan
FR	France			VN	Viet Nam
GA	Gabon				

AIRCRAFT IDENTIFICATION AND
DOCKING GUIDANCE SYSTEMS

BACKGROUND OF THE INVENTION

5 Field Of The Invention

This invention relates to systems for locating, identifying and tracking objects. More particularly, it relates to aircraft location, identification and docking guidance systems and to ground traffic control methods for locating and identifying objects on an airfield and for safely and efficiently docking aircraft at such airport.

10 Description Of Related Art

In recent years there has been a significantly increased amount of passenger, cargo and other aircraft traffic including take offs, landings and other aircraft ground traffic. Also there has been a marked increase in the number of ground support vehicles which are required to off load cargo, provide catering services and on going maintenance and support
15 of all aircraft. With this substantial increase in ground traffic has come a need for greater control and safety in the docking and identification of aircraft on an airfield.

Exemplary of prior art systems which have been proposed for detecting the presence of aircraft and other traffic on an airfield are those systems disclosed in U.S. Patent 4,995,102; European Patent No. 188 757; and PCT Published Applications W0
20 93/13104 and W0 93/15416.

However, none of those systems have been found to be satisfactory for detection of the presence of aircraft on an airfield, particularly, under adverse climatic conditions causing diminished visibility such as encountered under fog, snow or sleet conditions. Furthermore, none of the systems disclosed in the prior references are capable of
25 identifying and verifying the specific configuration of an approaching aircraft. Still further, none of the prior systems provide adequate techniques for tracking and docking an aircraft at a designated stopping point such as an airport loading gate. Also, none of the prior systems have provided techniques which enable adequate calibration of the instrumentation therein.

30 Thus, it has been a continuing problem to provide systems which are sufficiently safe and reliable over a wide range of atmospheric conditions to enable detection of objects such as aircraft and other ground traffic on an airfield.

In addition, there has been a long standing need for systems which are not only capable of detecting objects such as aircraft, but which also provide for the effective

SUBSTITUTE SHEET (RULE 26)

identification of the detected object and verification of the identity of such object, for example, a detected aircraft with the necessary degree of certainty regardless of prevailing weather conditions and magnitude of ground traffic.

There has also been a long standing, unfulfilled need for systems which are
5 capable of accurately and efficiently tracking and guiding objects such as incoming aircraft to a suitable stopping point such as an airport loading gate. In addition, the provision of accurate and effective calibration techniques for such systems has been a continuing problem requiring resolution.

10 SUMMARY OF THE INVENTION

In order to overcome the foregoing problems, systems and methods are required which are capable of achieving accurate, safe, efficient and cost effective location of objects such as aircraft on an airfield and for proper identification and verification of the identity of such objects. In addition, systems and methods are required for tracking and
15 docking guidance of objects such as aircraft, particularly, in a real time operating mode. Furthermore, systems and methods are required for calibration of such operating systems.

Accordingly, it is a primary object of the present invention to provide such systems and methods. In this regard, it is a specific object of the present invention to provide docking guidance systems which are capable of determining the precise position as
20 well as verifying the identity of aircraft on an airfield. Another object of the invention is to provide information to an individual or individuals controlling the docking or parking of aircraft on an airfield via a display unit utilizing communications between the system and a personal computer and other methods for monitoring the overall method operation.

A further object is to provide the safety of digitally precise docking control and,
25 also, to provide for implementation of such control in an extremely cost effect manner.

A still further object is to provide for the display of aircraft docking information for use by a pilot, co-pilot or other personnel docking an aircraft including information concerning the closing rate distance from an appropriate stopping point for the aircraft. Another significant object is to provide for the automatic comparison and determination
30 that the aircraft positioning and incoming direction does not deviate from the appropriate path necessary for the particular type of aircraft being docked and, particularly, to provide visual feedback as to the closing distance in a countdown format from a display, positioned forward of the aircraft which contains the distance for docking, position to left or right of appropriate center line for docking and a check of the aircraft type.

SUBSTITUTE SHEET (RULE 26)

Yet another object is to provide systems which not only provide azimuth guidance to either the pilot or the co-pilot, but also provide for scanning of the apron to enable appropriate and safe docking of an aircraft. Another object is to provide systems which are particularly sensitive so that accurate parking positions are achieved within extremely
5 minimal tolerances.

A further object is to provide systems which are extremely flexible and allow for the implementation of new operational parameters such as adding new aircraft types, alternate or secondary parking stop positions and other related information in regard to identifying, guiding and docking aircraft on an airfield.

10 These and other objects of the invention are accomplished by providing systems and methods for detecting the presence of an object on an airfield employing light pulses such as laser pulses projected, for example, off of mirrors in the direction of an incoming object positioned within a capture zone on the airfield and collecting light pulses reflected
15 off the object which indicates the presence of the object. Likewise, this technique enables the determination of the aircraft's position within the capture zone as well as the detection thereof.

The present invention also provides systems and methods for verifying the identity of the detected object which, for example, enables a determination that the correct type of aircraft is approaching the docking facility and is to be docked therein. Such verification
20 systems and methods involve the projection of light pulses such as laser pulses in angular coordinates onto an object and collecting reflected pulses off of the object in a detection device which enables a comparison of the reflected pulses to be made with a profile corresponding to the shape of a known object in order to determine whether the detected shape corresponds to the known shape.

25 Furthermore, the present invention provides systems and methods for tracking incoming objects wherein light pulses such as laser pulses are projected onto an incoming object and the light reflected from the object is collected and employed in order to ascertain the position of the object relative to an imaginary axial line projecting from a predetermined docking point and to detect the distance between the object and the predeter-
30 mined point for purposes of determining the location of the object.

Thus, the present invention provides for the location or capture of an approaching aircraft and for the identification or recognition of its shape within a designated capture zone or control area which is essential in initiating an aircraft docking procedure. Thereafter, in accordance with the present invention, a display is provided which enables

SUBSTITUTE SHEET (RULE 26)

docking of the identified aircraft in an appropriate docking area for off loading of passengers, cargo and the like.

The present invention accomplishes these features while eliminating the heretofore standard need for sensors which must be embedded in the apron of the docking areas. This results in a significant reduction not only in installation time and associated costs but, also, reduces maintenance costs thereafter. Furthermore, this invention permits retrofitting of the present systems into existing systems without requiring apron construction and the accompanying interruption in use of the airport docking areas which has been required with prior devices previously used for docking guidance systems.

10 In preferred embodiments of the systems of the present invention, a pilot bringing an aircraft into a gate at an airport is provided with a real time display mounted, for example, above the gate which indicates the aircraft's position relative to the point where the pilot must start to brake the plane. Also displayed is the aircraft's lateral position compared to a predetermined line for a plane of its type to follow in order to most
15 expeditiously arrive at the gate.

The software employed in the systems of the present invention preferably comprises four modules which perform the main computational tasks of the system and control the hardware. These modules include one for capture, one for identification, one for tracking and one for calibration of the system.

20 In a preferred embodiment of this invention, the capture module is employed to direct the devices for projecting light pulses to scan the area in front of a docking gate. Thus, when mirrors are employed to reflect and project pulses such as laser pulses, the capture module continues to direct the laser to scan this area until it detects an object entering the area. Once it detects an object, the capture module computes the distance and
25 the angular position of the object and passes control onto the tracking module.

Once activated, the tracking module follows the incoming aircraft to the gate while providing information about its lateral location and distance relative to the desired stopping point. Using this information, the pilot can correct the course of the plane and brake at the precise point that will result in stopping the aircraft in a desired docking
30 position in alignment with the gate. During the tracking, an identification module first scans the detected object to determine if its profile matches the reference profile of the type of aircraft expected. If the profiles do not match, the system informs the airport tower and a signal is transmitted for stopping the docking function.

Finally, the calibration module calibrates the distance and angular measurements to

SUBSTITUTE SHEET (RULE 26)

ensure that the readings of the detection devices such as a Laser Range Finder accurately correspond to the distance and angle of the aircraft. This module runs periodically during the capture and tracking modules to determine the continued accuracy of the system.

5 BRIEF DESCRIPTION OF THE DRAWINGS

The features and advantages of the invention will become apparent from the following detailed description taken in connection with the accompanying drawings wherein:

- Fig 1 is a view illustrating the system as in use at an airport;
- 10 Fig 2 is a diagrammatic view illustrating the general componentry of a preferred system in accordance with the present invention;
- Fig 3 is a top plan view illustrating the detection area in front of a docking gate which is established for purposes of detection and identification of approaching aircraft;
- 15 Fig 4 is a flow chart illustrating the main routine and the docking mode of the system;
- Fig 5 is a flow chart illustrating the calibration mode of the system;
- Fig 6 is a view illustrating the components of the calibration mode;
- Fig 7 is a flow chart illustrating the capture mode of the system;
- 20 Fig 8 is a flow chart illustrating the tracking phase of the system;
- Fig 9 is a flow chart illustrating the height measuring phase of the system; and
- Fig 10 is a flow chart illustrating the identification phase of the system.
- Table I is a preferred embodiment of a Horizontal Reference Profile Table which is employed to establish the identity of an aircraft in the systems of the present invention;
- 25 Table II is a preferred embodiment of a Comparison Table which is employed in the systems of the present invention for purposes of effectively and efficiently docking an aircraft;

30

DETAILED DESCRIPTION OF THE PREFERRED EMBODIMENTS

Reference is now made to Figures 1-10 and Tables I-II. in which like numerals designate like elements throughout the several views. Throughout the following detailed description, numbered stages depicted in the illustrated flow diagrams are generally indi-

SUBSTITUTE SHEET (RULE 20)

cated by element numbers in parenthesis following such references

Referring to Fig. 1, the systems of the present invention generally designated 10 in the drawings provide for the computerized location of an object, verification of the identity of the object and tracking of the object, the object preferably being an aircraft 12. In operation, once the control tower 14 lands an aircraft 12, it informs the system that a plane is approaching the gate 16 and the type of aircraft (i.e., 747, L-1011, etc.) expected. The system 10 then scans the area in front of the gate 16 until it locates an object that it identifies as an airplane 12. The system 10 then compares the profile of the aircraft 12 with a reference profile for the expected type of aircraft. If the located aircraft does not match the expected profile, the system informs or signals the tower 14 and shuts down.

If the object is the expected aircraft 12, the system 10 tracks it into the gate 16 by displaying in real time to the pilot the distance remaining to the proper stopping point 29 and the lateral position 31 of the plane 12. The lateral position 31 of the plane 12 is provided on a display 18 allowing the pilot to correct the position of the plane to approach the gate 16 from the correct angle. Once the airplane 12 is at its stopping point 53, this fact is shown on the display 18 and the pilot stops the plane. Employing the system 10 of the present invention, it should be noted that once the plane 12 comes to rest, it is accurately aligned with the gate 16 requiring no adjustment of the gate 16 by the ground staff.

Referring to Fig. 2, the system 10 consists of a Laser Range Finder (LRF) 20, two mirrors 21, 22, a display unit 18, two step motors 24, 25, and a microprocessor 26. Suitable LRF products for use herein are sold by Laser Atlanta Corporation and are capable of emitting laser pulses and receiving the reflections of those pulses reflected off of distant objects and computing the distance to those objects.

The system 10 is arranged such that there is a connection 28 between the serial port of the LRF 20 and the microprocessor 26. Through this connection, the LRF 20 sends measurement data approximately every 1/400th of a second to the microprocessor 26. The hardware components generally designated 23 of the system 10 are controlled by the programmed microprocessor 26. In addition, the microprocessor 26 feeds data to the display 18. As the interface to the pilot, the display unit 18 is placed above the gate 16 to show the pilot how far the plane is from its stopping point 29, the type of aircraft 30 the system believes is approaching and the lateral location of the plane 31. Using this display, the pilot can adjust the approach of the plane 12 to the gate 16 to ensure the plane is on the correct angle to reach the gate. If the display 18 is showing the wrong aircraft type 30,

SUBSTITUTE SHEET (RULE 26)

the pilot can abort the approach before any damage is done. This double check ensures the safety of the passengers, plane and airport facilities because if the system tries to maneuver a larger 747 as if it was a 737, it likely will cause extensive damage.

In addition to the display 18, the microprocessor 26 processes the data from the LRF 20 and controls the direction of the laser 20 through its connection 32 to the step motors 24, 25. The step motors 24, 25 are connected to the mirrors 21, 22 and move them in response to instructions from the microprocessor 26. Thus, by controlling the step motors 24, 25, the microprocessor 26 can change the angle of the mirrors 21, 22 and aim the laser pulses from the LRF 20.

The mirrors 21, 22 aim the laser by reflecting the laser pulses outward over the tarmac of the airport. In the preferred embodiment, the LRF 20 does not move. The scanning by the laser is done with mirrors. One mirror 22 controls the horizontal angle of the laser while the other mirror 21 controls the vertical angle. By activating the step motors 24, 25, the microprocessor 26 controls the angle of the mirrors and thus the direction of the laser pulse.

The system 10 controls the horizontal mirror 22 to achieve a continuous horizontal scanning within a ± 10 degree angle in approximately 0.1 degree angular steps which are equivalent to 16 microsteps per step with the Escap EDM-453 step motor. One angular step is taken for each reply from the reading unit, i.e., approximately every 2.5 ms. The vertical mirror 21 can be controlled to achieve a vertical scan between $+20$ and -30 degrees in approximately 0.1 degree angular steps with one step every 2.5 ms. The vertical mirror 21 is used to scan vertically when the nose height is being determined and when the aircraft 12 is being identified. During the tracking mode, the vertical mirror 21 is continuously adjusted to keep the horizontal scan tracking the nose tip of the aircraft 12.

Referring to Fig. 3, the system 10 divides the field in front of it by distance into three parts. The farthest section, from about 50 meters out, is the capture zone 50. In this zone 50, the system 10 detects the aircraft's nose and makes a rough estimate of lateral and longitudinal position of the aircraft 12. Inside the capture zone 50 is the identification area 51. In this area, the system 10 checks the profile of the aircraft 12 against a stored profile. The system 10 shows the lateral position of the aircraft 12 in this region, related to a predetermined line, on the display 18. Finally, nearest to the LRF 20 is the display or tracking area 52. In the display area 52, the system 10 displays the lateral and longitudinal position of the aircraft 12 relative to the correct stopping position with its highest degree of accuracy. At the end of the display area 52 is the stopping point 53. At the stopping point

SUBSTITUTE SHEET (RULE 26)

53, the aircraft will be in the correct position at the gate 16.

In addition to the hardware and software, the system 10 maintains a database containing reference profiles for any type of aircraft it might encounter. Within this database, the system stores the profile for each aircraft type as a horizontal and vertical
5 profile reflecting the expected echo pattern for that type of aircraft.

Referring to Table I, the system maintains the horizontal profile in the form of a Table I whose rows 40 are indexed by angular step and whose columns 41 are indexed by distance from the stopping position for that type of aircraft. In addition to the indexed rows, the table contains a row 42 providing the vertical angle to the nose of the plane at
10 each distance from the LRF, a row 44 providing the form factor, k, for the profile and a row 45 providing the number of profile values for each profile distance. The body 43 of the Table I contains expected distances for that type of aircraft at various scanning angles and distances from the stopping point 53.

Theoretically, the 50 angular steps and the 50 distances to the stopping point 53
15 would require a Table I containing 50 x 50, or 2500, entries. However, the Table I will actually contain far fewer entries because the profile will not expect a return from all angles at all distances. It is expected that a typical table will actually contain between 500 and 1000 values. Well known programming techniques provide methods of maintaining a partially full table without using the memory required by a full table.

20 In addition to the horizontal profile, the system 10 maintains a vertical profile of each type of aircraft. This profile is stored in the same manner as the horizontal profile except its rows are indexed by angular steps in the vertical direction and its column index contains fewer distances from the stopping position than the horizontal profile. The vertical profile requires fewer columns because it is used only for identifying the aircraft 12 and
25 for determining its nose height, which take place at a defined range of distances from the LRF 20 in the identification area 51. Consequently, the vertical profile stores only the expected echoes in that range without wasting data storage space on unneeded values.

The system 10 uses the previously described hardware and database to locate, identify and track aircraft using the following procedures:

30 Referring to Fig. 4, the software running on the microprocessor performs a main routine containing subroutines for the calibration mode 60, capture mode 62 and docking mode 64. The microprocessor first performs the calibration mode 60, then the capture mode 62 and then the docking mode 64. Once the aircraft 12 is docked, the program finishes. These modes are described in greater detail as follows:

SUBSTITUTE SHEET (RULE 26)

Calibration Mode

To ensure system accuracy, the microprocessor 26 is programmed to calibrate itself in accordance with the procedure illustrated in Fig. 5 before capturing an aircraft 12 and at various intervals during tracking. Calibrating the system 10 ensures that the relationship between the step motors 24, 25 and the aiming direction is known. The length measuring ability of the LRF 20 is also checked

Referring to Fig. 6, for calibration, the system 10 uses a square plate 66 with a known position. The plate 66 is mounted 6 meters from the LRF 20 and at the same height as the LRF 20.

To calibrate, the system sets (α, β) to $(0, 0)$ causing the laser to be directed straight forward. The vertical mirror 22 is then tilted such that the laser beam is directed backwards to a rear or extra mirror 68 which redirects the beam to the calibration plate 66. (100) The microprocessor 26 then uses the step motors 24, 25 to move the mirrors 21, 22 until it finds the center of the calibration plate 66. Once it finds the center of the calibration plate 66, the microprocessor 26 stores the angles $(\alpha_{cp}, \beta_{cp})$ at that point and compares them to stored expected angles. (102) The system 10 also compares the reported distance to the plate 66 center with a stored expected value. (102) If the reported values do not match the stored values, the microprocessor 26 changes the calibration constants, which determine the expected values, until they do. (104, 106) However, if any of these values deviate too much from the values stored at installation, an alarm is given. (108)

Capture Mode

Initially, the airport tower 14 notifies the system 10 to expect an incoming airplane 12 and the type of airplane to expect. This signal puts the software into a capture mode 62 as outlined in Fig. 8. In capture mode 62, the microprocessor 26 uses the step motors 24, 25 to direct the laser to scan the capture zone 50 horizontally for the plane 12. This horizontal scan is done at a vertical angle corresponding to the height of the nose of the expected type of aircraft at the midpoint of the capture zone 50.

To determine the correct height to scan, the microprocessor 26 computes the vertical angle for the laser pulse as:

$$\beta_f = \arctan [(H-h)/l_f]$$

where H = the height of the LRF 20 above the ground, h = the nose height of the expected aircraft, and l_f = the distance from the LRF 20 to the middle of the capture zone 50. This equation results in a vertical angle for the mirror 21 that will enable the search to be at the correct height at the middle of the capture zone 50 for the expected airplane 12.

SUBSTITUTE SHEET (RULE 26)

Alternatively, the system 10 can store in the database values for β_f for different types of aircraft at a certain distance. However, storing β_f limits the flexibility of the system 10 because it can capture an aircraft 12 only at a single distance from the LRF 20.

In the capture zone 50 and using this vertical angle, the microprocessor 26 directs
5 the laser to scan horizontally in pulses approximately 0.1 degree apart. The microprocessor 26 scans horizontally by varying α , the horizontal angle from a center line starting from the LRF 20, between $\pm\alpha_{\max}$, a value defined at installation. Typically, α_{\max} is set to 50 which, using 0.1 degree pulses, is equivalent to 5 degrees and results in a 10 degree scan.

The release of the laser pulses results in echoes or reflections from objects in the
10 capture zone 50. The detection device of the LRF 20 captures the reflected pulses, computes the distance to the object from the time between pulse transmission and receipt of the echo, and sends the calculated distance value for each echo to the microprocessor 26. The micro processor 26 stores, in separate registers in a data storage device, the total number of echoes or hits in each 1 degree sector of the capture zone 50. (70) Because the
15 pulses are generated in 0.1 degree intervals, up to ten echoes can occur in each sector. The microprocessor 26 stores these hits in variables entitled s_α where α varies from 1 to 10 to reflect each one degree slice of the ten degree capture zone 50.

In addition to storing the number of hits per sector, the microprocessor 26 stores, again in a data storage device, the distance from the LRF 20 to the object for each hit or
20 echo. Storing the distance to each reflection requires a storage medium large enough to store up to ten hits in each 1 degree of the capture zone 50 or up to 100 possible values. Because, in many cases, most of the entries will be empty, well known programming techniques can reduce these storage requirements below having 100 registers always allocated for these values.

25 Once this data is available for a scan, the microprocessor 26 computes the total number of echoes, S_T , in the scan by summing the s_α 's. The microprocessor 26 then computes S_M , the largest sum of echoes in three adjacent sectors. (72) In other words, S_M is the largest sum of $(S_{\alpha-1}, S_\alpha, S_{\alpha+1})$.

Once it computes S_M and S_T , the microprocessor 26 determines whether the
30 echoes are from an incoming airplane 12. If S_M is not greater than 24, no airplane 12 has been found and the microprocessor 26 returns to the beginning of the capture mode 62. If the largest sum of echoes, S_M is greater than 24 (74), a "possible" airplane 12 has been located. If a "possible" airplane 12 has been located, the microprocessor checks if S_M/S_T is greater than 0.5 (76), or the three adjacent sectors with the largest sum contain at least half

SUBSTITUTE SHEET (RULE 26)

of all the echoes received during the scan.

If S_M/S_T is greater than 0.5, the microprocessor 26 calculates the location of the center of the echo. (78, 82) The angular location of the center of the echo is calculated as:

$$\alpha_t = \alpha_v + (S_{\alpha+1} - S_{\alpha-1}) / (S_{\alpha-1} + S_{\alpha} + S_{\alpha+1})$$

5 where S_{α} is the S_{α} that gave S_M and α_v is the angular sector that corresponds to that S_{α} .

The longitudinal position of the center of the echo is calculated as:

$$l_t = (1/n) \sum_{i=1}^{10} l_{avi}$$

where the l_{avi} are the measured values, or distances to the object, for the pulses that returned an echo from the sector α_v and where n is the total number of measured values
10 in this sector. (78, 82) Because the largest possible number of measured values is ten, n must be less than or equal to ten.

However, if $S_M/S_T < 0.5$, the echoes may have been caused by snow or other aircraft at close range. If the cause is an aircraft at close range, that aircraft is probably positioned fairly close to the centerline so it is assumed that α_t should be zero instead of
15 the above calculated value and that l_t should be the mean distance given by the three middle sectors. (80) If the distance distribution is too large, the microprocessor 26 has not found an airplane 12 and it returns to the beginning of the capture mode 62. (81).

After calculating the position of the aircraft 12, the system 10 switches to docking mode 64.

20 Docking Mode

The docking mode 64, illustrated in Fig. 4, includes three phases, the tracking phase 84, the height measuring phase 86 and the identification phase 88. In the tracking phase 84, the system 10 monitors the position of the incoming aircraft 12 and provides the pilot with information about axial location 31 and distance from the stopping point 53 of
25 the plane through the display 18. The system 10 begins tracking the aircraft 12 by scanning horizontally.

Referring to Fig. 8, during the first scan in tracking phase 84, the microprocessor 26 directs the LRF 20 to send out laser pulses in single angular steps, α , or, preferably, at 0.1 degree intervals between:

30 $(\alpha_t - \alpha_p - 10)$ and $(\alpha_t + \alpha_p + 10)$

where α_t is determined during the capture mode 62 as the angular position of the echo center and α_p is the largest angular position in the current profile column that contains distance values.

After the first scan, α is stepped back and forth with one step per received LRF

SUBSTITUTE SHEET (RULE 26)

value between:

$$(\alpha_s - \alpha_p - 10) \text{ and } (\alpha_s + \alpha_p + 10)$$

where α_s is the angular position of the azimuth determined during the previous scan.

During the tracking phase 84, the vertical angle, β , is set to the level required for the identified craft 12 at its current distance from the LRF 20 which is obtained from the reference profile Table I. The current profile column is the column representing a position less than but closest to l_i .

The microprocessor 26 uses the distance from the stopping point 53 to find the vertical angle for the airplane's current distance on the profile Table I. During the first scan, the distance, l_i , calculated during the capture mode 62, determines the appropriate column of the profile Table I and thus the angle to the aircraft 12. For each subsequent scan, the microprocessor 26 uses the β in the column of the profile Table I reflecting the present distance from the stopping point 53. (112)

Using the data from the scans and the data on the horizontal profile Table I, the microprocessor 26 creates a Comparison Table II. Referring to Table II the Comparison Table II is a two dimensional table with the number of the pulse, or angular step number, as the index 91, i , to the rows. Using this index, the following information, represented as columns of the table, can be accessed for each row: l_i 92, the measured distance to the object on this angular step, l_{ki} 93, the measured value compensated for the skew caused by the displacement (equal to l_i minus the quantity s_m , the total displacement during the last scan, minus the quantity i times s_p , the average displacement during each step in the last scan (i.e. $l_i - (s_m - is_p)$), d_i 94, the distance between the generated profile and the reference profile (equal to r_{ij} , the profile value for the corresponding angle at the profile distance j , minus l_{ki}), a_i 95, the distance between the nose of the aircraft and the measuring equipment (equal to r_{j50} , the reference profile value at zero degrees, minus d_i), a_e 96, the estimated nose distance after each step (equal to a_m , the nose distance at the end of the last scan, minus the quantity i times s_p), a_d , the difference between the estimated and measured nose distance (equal to the absolute value of a_i minus a_e), and Note 97 which indicates the echoes that are likely caused by an aircraft.

During the first scan in the tracking phase 84, the system 10 uses the horizontal profile column representing an aircraft position, j , less than but closest to the value of l_i . For each new scan, the profile column whose value is less than but closest to $(a_m - s_m)$ is chosen where a_m is the last measured distance to the aircraft 12 and s_m is the aircraft's displacement during the last scan. Additionally, the values of the profile are shifted

SUBSTITUTE SHEET (RULE 26)

sideways by α_s to compensate for the lateral position of the aircraft. (112)

During each scan, the microprocessor 26 also generates a Distance Distribution Table (DDT). This table contains the distribution of a_i values as they appear in the Comparison Table II. Thus, the DDT has an entry representing the number of occurrences
 5 of each value of a_i in the Comparison Table II in 1 meter increments between 10 to 100 meters.

After every scan, the system 10 uses the DDT to calculate the average distance, a_m , to the correct stopping point 53. The microprocessor 26 scans the data in the DDT to find the two adjacent entries in the DDT for which the sum of their values is the largest.
 10 The microprocessor 26 then flags the Note 97 column in the Comparison Table II for each row containing an entry for a_i corresponding to either of the two DDT rows having the
 -- largest sum. (114)

The system 10 then determines the lateral deviation or offset. (116) The microprocessor 26 first sets:

$$15 \quad 2d = \alpha_{\max} - \alpha_{\min}$$

where α_{\max} and α_{\min} are the highest and lowest α values for a continuous flagged block of d_i values in the Comparison Table II. Additionally, the microprocessor 26 calculates:

$$Y_1 = \sum d_i$$

for the upper half of the flagged d_i in the block and:

$$20 \quad Y_2 = \sum d_i$$

for the lower half of the block. Using Y_1 and Y_2 , "a" 116 is calculated as:

$$a = k \times (Y_1 - Y_2)/d^2$$

where k is given in the reference profile. If "a" exceeds a given value, preferably set to one, it is assumed that there is a lateral deviation approximately equal to "a". The l_i
 25 column of the Comparison Table II is then shifted "a" steps and the Comparison Table II is recalculated. This process continues until "a" is smaller than an empirically established value, preferably one. The total shift, α_s , of the l_i column is considered equal to the lateral deviation or offset. (116) If the lateral offset is larger than a predetermined value, preferably set to one, the profile is adjusted sideways before the next scan. (118, 120)

30 After the lateral offset is checked, the microprocessor 26 provides the total sideways adjustment of the profile, which corresponds to the lateral position 31 of the aircraft 12, on the display 18. (122)

The microprocessor 26 next calculates the distance to the nose of the aircraft, a_m ,
 as:

SUBSTITUTE SHEET (RULE 26)

$$a_m = \Sigma(\text{flagged } a_i)/N$$

where N is the total number of flagged a_i . From a_m , the microprocessor 26 can calculate the distance from the plane 12 to the stopping point 53 by subtracting the distance from the LRF 20 to the stopping point 53 from the distance to the nose of the aircraft. (124)

5 Once it calculates of the distance to the stopping point 53, the microprocessor 26 calculates the average displacement during the last scan, s_m . The displacement during the last scan is calculated as:

$$S_m = a_{m-1} - a_m$$

where a_{m-1} and a_m belong to the last two scans. For the first scan in tracking phase 84, S_m
10 is set to 0.

The average displacement s_p during each step is calculated as:

$$S_p = S_m / P$$

where P is the total number of steps for the last scan cycle.

15 The microprocessor 26 will inform the pilot of the distance to the stopping position 53 by displaying it on the display unit 18, 29. By displaying the distance to the stopping position 29, 53 after each scan, the pilot receives constantly updated information in real time about how far the plane 12 is from stopping.

20 If the aircraft 12 is in the display area 52, both the lateral 31 and the longitudinal position 29 are provided on the display 18. (126, 128) Once the microprocessor 26 displays the position of the aircraft 12, the tracking phase ends.

25 Once it completes the tracking phase, the microprocessor 26 verifies that tracking has not been lost by checking that the total number of rows flagged divided by the total number of measured values, or echoes, in the last scan is greater than 0.5. (83) In other words, if more than 50% of the echoes do not correspond to the reference profile, tracking is lost. If tracking is lost and the aircraft 12 is greater than 12 meters from the stopping point, the system 10 returns to the capture mode 62. (85) If tracking is lost and the aircraft 12 is less than or equal to 12 meters from the stopping point 53, the system 10 turns on the stop sign to inform the pilot that it has lost tracking. (85, 87)

30 If tracking is not lost, the microprocessor 26 determines if the nose height has been determined. (130) If the height has not yet been determined, the microprocessor 26 enters the height measuring phase 86. If the height has already been determined, the microprocessor 26 checks to see if the aircraft has been identified. (132)

In the height measuring phase, illustrated in Fig. 9, the microprocessor 26 determines the nose height by directing the LRF 20 to scan vertically. The nose height is

SUBSTITUTE SHEET (RULE 26)

used by the system to ensure that the horizontal scans are made across the tip of the nose.

To check the nose height, the microprocessor 26 sets β to a predetermined value β_{\max} and then steps it down in 0.1 degree intervals once per received/reflected pulse until it reaches β_{\min} , another predetermined value. β_{\min} and β_{\max} are set during installation and typically are -20 and 30 degrees respectively. After β reaches β_{\min} the microprocessor 26 directs the step motors 24, 25 up until it reaches β_{\max} . This vertical scanning is done with α set to α_s , the azimuth position of the previous scan.

Using the measured aircraft distance, the microprocessor 26 selects the column in the vertical profile table closest to the measured distance. (140) Using the data from the scan and the data on the vertical profile table, the microprocessor 26 creates a Comparison Table II. Referring to Fig.4, the Comparison Table II is a two dimensional table with the number of the pulse, or angular step number, as an index 91, i. to the rows. Using this index, the following information, represented as columns of the table, can be accessed for each row: l_i 92, the measured distance to the object on this angular step, l_{ki} 93, the measured value compensated for the skew caused by the displacement (equal to l_i minus the quantity S_m , the total displacement during the last scan, minus the quantity i times s_p , the average displacement during each step in the last scan), d_i 94, the distance between the generated profile and thereference profile (equal to r_{ij} , the profile value for the corresponding angle at the profile distance j , minus l_{ki}), a_i 95, the distance between the nose of the aircraft and the measuring equipment (equal to r_{j50} , the reference profile value at zero degrees, minus d_i), a_e 96, the estimated nose distance after each step (equal to a_m , the nose distance at the end of the last scan, minus the quantity i times s_p), a_d , the difference between the estimated and measured nose distance (equal to the absolute value of a_i minus a_e), and Note 97 which indicates echoes that are likely caused by an aircraft 12.

During each scan, the microprocessor 26 also generates a Distance Distribution Table (DDT). This table contains the distribution of a_i values as they appear in the Comparison Table II. Thus, the DDT has an entry representing the number of occurrences of each value of a_i in the Comparison Table II in 1 meter increments between 10 to 100 meters.

After every scan, the system 10 uses the DDT to calculate the average distance, a_m , to the correct stopping point 53. The microprocessor 26 scans the data in the DDT to find the two adjacent entries in the DDT for which the sum of their values is the largest. The microprocessor 26 then flags the Note 97 column in the Comparison Table II for each row containing an entry for a_i corresponding to either of the two DDT rows having the

SUBSTITUTE SHEET (RULE 26)

largest sum. (142)

Once it completes the calculation of the average distance to the correct stopping point 53, the microprocessor 26 calculates the average displacement during the last scan, s_m . The displacement during the last scan is calculated as:

$$5 \quad s_m = a_{m-1} - a_m$$

where a_{m-1} and a_m belong to the last two scans. For the first scan in tracking phase 84, s_m is set to 0. The average displacement s_p during each step is calculated as

$$s_p = s_m / P$$

where P is the total number of steps for the last scan cycle.

- 10 Calculating the actual nose height is done by adding the nominal nose height, predetermined height of the expected aircraft when empty, to the vertical or height deviation. Consequently, to determine the nose height, the system 10 first determines the vertical or height deviation. (144) Vertical deviation is calculated by setting:

$$2d = \beta_{\max} - \beta_{\min}$$

- 15 where β_{\max} and β_{\min} are the highest and lowest β value for a continuous flagged block of d_i values in the Comparison Table II. Additionally, the microprocessor 26 calculates:

$$Y_1 = \sum d_i$$

for the upper half of the flagged d_i in the block and:

$$Y_2 = \sum d_i$$

- 20 for the lower half of the block. Using Y_1 and Y_2 , "a" is calculated as

$$a = k \times (Y_1 - Y_2) / d^2$$

where k is given in the reference profile. If "a" exceeds a given value, preferably one, it is assumed that there is a vertical deviation approximately equal to "a". The l_i column is then shifted "a" steps, the Comparison Table II is re-screened and "a" recalculated. This process

- 25 continues until "a" is smaller than the given value, preferably one. The total shift, β_s of the l_i column is considered equal to the height deviation. (144) The β_j values in the vertical Comparison Table II are then adjusted as $\beta_j + \Delta\beta_j$ where the height deviation $\Delta\beta_j$ is:

$$\Delta\beta_j = \beta_s \times (a_{m\beta} + a_s) / (a_j + a_s)$$

and where $a_{m\beta}$ is the valid a_m value when β_s was calculated.

- 30 Once the height deviation is determined, the microprocessor 26 checks if it is bigger than a predetermined value, preferably one. (146) If the deviation is larger than that value, the microprocessor 26 adjusts the profile vertically corresponding to that offset. (148) The microprocessor 26 stores the vertical adjustment as the deviation from the nominal nose height. (150) The actual height of the aircraft is the nominal nose height plus

SUBSTITUTE SHEET (RULE 26)

the deviation. Once it completes the height measuring phase 86, the microprocessor 26 returns to the tracking phase 84.

If the microprocessor 26 has already determined the nose height, it skips the height measuring phase 86 and determines whether the aircraft 12 has been identified.

5 (130, 132) If the aircraft 12 has been identified, the microprocessor 26 checks whether the aircraft 12 has reached the stop position. (134) If the stop position is reached, the microprocessor 26 turns on the stop sign and the system 10 has completed the docking mode 64. (136) If the aircraft 12 has not reached the stop position, the micro-processor 26 returns to the tracking phase 84. (134)

10 If the aircraft 12 is not identified, the microprocessor 26 checks whether the aircraft 12 is less than or equal to 12 meters from the stopping position 53. (133) If the aircraft 12 not more than 12 meters from the stopping position 53, the system 10 turns on the stop sign to inform the pilot that identification has failed (135) After displaying the stop sign, the system 10 shuts down.

15 If the aircraft 12 is more than 12 meters from the stopping point 53; the microprocessor 26 enters the identification phase illustrated in Fig.10. (133, 88) In the identification phase 88, the microprocessor 26 creates a Comparison Table II to reflect the results of another vertical scan and the contents of the profile table. (152, 154) Another vertical scan is performed in the identification phase 88 because the previous scan may have provided
20 sufficient data for height determination but not enough for identification. In fact, several scans may need to be done before a positive identification can be made. After calculating the vertical offset 156, checking that it is not too large 158 and adjusting the profile vertically corresponding to the offset 160 until the offset drops below a given amount, preferably one, the microprocessor 26 calculates the average distance between marked echoes and
25 the profile and the mean distance between the marked echoes and this average distance. (162)

The average distance d_m between the measured and corrected profile and the deviation T from this average distance is calculated after vertical and horizontal scans as follows:

$$30 \quad d_m = \sum d_i / N$$

$$T = \sum |d_i - d_m| / N$$

If T is less than a given value, preferably 5, for both profiles, the aircraft 12 is judged to be of the correct type provided that a sufficient number of echoes are received. (164)

Whether a sufficient number of echoes is received is based on.

SUBSTITUTE SHEET (RULE 26)

$$N/\text{size} > 0.75$$

where N is the number of "accepted" echoes and "size" is the maximum number of values possible. If the aircraft 12 is not of the correct type, the microprocessor turns on the stop sign 136 and suspends the docking mode 64. Once the microprocessor 26 completes the
5 identification phase 88, it returns to the tracking phase 84.

While the present invention has been described in connection with particular embodiments thereof, it will be understood by those skilled in the art that many changes may be made without departing from the true spirit and scope of the present invention as set forth in the following claims.

10 ---

SUBSTITUTE SHEET (RULE 26)

Table I

5						
			41			
	42	78.25	78	77.5	...	23
	44	5	5	5.6	...	10
10	45	1	2	3	...	50
	0	xx	xx	xx	...	xx
	1	xx	xx	xx	...	xx
	2	xx	xx	xx	...	xx
15	3	xx	xx	xx	...	xx
	4	xx	xx	xx	...	xx
10	5	xx	xx	xx	...	xx
	6	xx	xx	xx	...	xx
	7	xx	xx	xx	...	xx
20	8	xx	xx	xx	...	xx
	9	xx	xx	xx	...	xx
25	50	xx	xx	xx	...	xx

43

SUBSTITUTE SHEET (RULE 26)

Table II

	91 i	92 l_i	93 l_{ki}	94 d_i	95 a_i	96 a_c	97 Note
5							
10	1	xx	xx	xx	xx	xx	xx
	2	xx	xx	xx	xx	xx	xx
	3	xx	xx	xx	xx	xx	xx
	4	xx	xx	xx	xx	xx	xx
15	5	xx	xx	xx	xx	xx	xx
	6	xx	xx	xx	xx	xx	xx
20	50	xx	xx	xx	xx	xx	xx
	100	xx	xx	xx	xx	xx	xx
25							

SUBSTITUTE SHEET (RULE 26)

WE CLAIM:

1. A system for verifying the shape of a detected object comprising:
means for projecting light pulses in angular coordinates onto an object;
means for collecting light pulses reflected off said object and for determining the
5 detected shape of said object; and
means for comparing said detected shape with a profile corresponding to the shape
of a known object and for determining whether said detected shape
corresponds to said known shape.
2. The system of claim 1 wherein the light pulses are projected onto a mirror system
10 with means for adjusting the mirror system to project the light pulses outwardly.
3. The system of claims 1- 2 wherein the profile corresponding to the shape of a
known object comprises sets of expected reflected pulses at various distances from the
stopping point.
4. The system of claims 1-3 further including means for detecting the presence of an
15 object within a capture zone, said detection means comprising:
said adjustable mirror system projects said light pulses outwardly in a predeter-
mined plane such that said projected light pulses will reflect off an object
within a capture zone;
means for processing collected light pulses reflected off said object within the
20 capture zone to enable detection of the presence of such object.
5. The system of claim 4 wherein said capture zone comprises an area within said
plane of said projected light pulses, said area being defined as a predetermined angular
configuration relative to an axis extending from said mirror system and at predetermined
axial distances from said mirror system, said area being divided into multiple angular
25 sectors defined by rays extending outwardly from said mirror system. 6. The system of
claims 4-5 wherein said capture zone is repetitiously scanned with said light pulses
projected in said predetermined plane until an object is detected based on the processing of
said collected light pulses reflected off said object.
7. The system of claim 4-6 wherein said object is an airplane having a nose section
30 positioned a predetermined vertical height above a surface of an airfield.
8. The system of claims 4-7 wherein said adjustable mirror system projects said light
pulses at a predetermined angle relative to said surface of said airfield so that said light
pulses intersect with said nose section of said airplane.
9. The system of claims 2-8 wherein said adjustable mirror system is operated by

SUBSTITUTE SHEET (RULE 26)

step motors under the control of a programmed microprocessor

10. The system of claims 2-9 including a microprocessor for adjusting the mirror system so that the projected light pulses scan the capture zone and a data storage device for receiving data concerning the light pulses reflected off an object, said data storage device
5 containing comparative information for comparison with the received data and said microprocessor employing said received data and said comparative information to determine whether an object has entered the capture zone.

11. The system of claim 10 wherein said received data includes the number of pulses reflected off a detected object in each sector of the capture zone and said comparative
10 information includes data for determining the distance between a detected object and said means for collecting the light pulses.

12. The system of claims 9-10 wherein:
the microprocessor totals the number of reflected pulses in each scan of said
capture zone;
15 said microprocessor determines the largest sum of reflected pulses for three adjacent sectors; and
said microprocessor determines that an object has been detected if the largest sum of reflected pulses for three adjacent sectors is at least a predetermined minimum number out of a total number of pulses projected within said
20 three adjacent sectors and the number of reflected pulses in the three sectors with the largest sum is more than half of the total number of reflected pulses in the scan of said capture zone.

13. The system of claims 1-12 further including means for tracking an incoming object, said tracking means comprising:
25 means for detecting the position of said incoming object relative to an imaginary axial line projecting from a predetermined point and for detecting the distance between said object and said predetermined point whereby tracking of the location of said object is enabled.

14. The system of claim 13 wherein:
30 a comparison table is generated containing information about collected light pulses and said information is compared with a profile table indicating the shape of known objects;
a distance distribution table is generated recording the distribution of distances from the object to said collection means for each collected light pulse; and

SUBSTITUTE SHEET (RULE 26)

an average distance is calculated from the detected position of said object to a desired stopping position for said object

15. The system of claims 14 wherein:
the average distance to the stopping position is calculated by averaging the
5 distance to said stopping position recorded for the entries in the
comparison table corresponding to the two adjacent entries in the distance
distribution table having the largest sum.
16. The system of claims 13-15 including a display indicating the distance from the
object to a stopping point, the type of object and the location of the object compared to
10 said imaginary axial line.
17. The system of claims 14-16 wherein the average stopping distance is communi-
cated to a computer on board the aircraft allowing that computer to stop the aircraft when
said aircraft reaches said stopping position.
18. The system of claims 1-17 further including means for directing said projected
15 light pulses onto a calibration element positioned in a known angular direction and at a
known distance from said means for directing said projected light for purposes of
calibration of said system.
19. The system of claim 18 wherein the means for directing said projected light
comprises a second mirror system.
20. 20. The system of claims 18-19 wherein:
said light pulses are reflected off said object and are received at a detector;
determining a detected angular direction of the object relative to said light
source based on said pulses received at said detector and in accordance
with predetermined angular parameters;
25 comparing said detected angular direction with said known angular direction to
determine whether said detected angular direction corresponds to said
known angular direction.
21. The system of claim 20 further comprising:
adjusting the angular parameters if said detected angular direction and said known
30 angular direction do not correspond so that the detected angular direction
is caused to correspond essentially to the known angular direction.
22. The system of claims 20-21 further comprising:
determining the detected distance of the object from said light source based on
predetermined distance parameters; comparing said detected distance with

SUBSTITUTE SHEET (RULE 26)

- a known distance of said object from said light source to determine whether said detected distance corresponds to said known distance.
23. The system of claims 20-22 further comprising:
adjusting the distance parameters if said detected distance and said known
5 distance do not correspond so that the detected distance is caused to correspond essentially to the known distance.
24. The system of claims 18-20 wherein the angular direction and distance of said calibration means from said means for directing said projected light in a horizontal plane are calibrated while the angular direction and distance of said calibration means from said
10 means for directing said projected light in a vertical plane are held constant.
25. The system of claims 1-24 wherein said light pulses are laser light pulses.
26. The system of claims 1-25 wherein said profile is stored in a memory device.
27. A system for tracking an incoming object comprising:
means for generating light pulses;
15 means for projecting said pulses outwardly onto an incoming object and for reflecting said light pulses off said object;
means for collecting the light pulses reflected off of said object;
means for detecting the position relative to an imaginary axial line projecting from a predetermined point and for detecting the distance between said object
20 and said predetermined point whereby tracking of the location of said object is enabled.
28. The tracking system of claim 27 wherein the light pulses are laser light pulses.
29. The tracking system of claim 27-28 wherein the light pulses are projected onto a mirror system with means for adjusting the mirror system to project the light pulses
25 outwardly onto an incoming object.
30. The tracking system of claims 27-29 wherein a microprocessor provides the means for monitoring the location of said object.
31. The tracking system of claims 27-30 wherein
a comparison table is generated reflecting information about the laser scan and is
30 compared with a profile table indicating the shape of known objects;
a distance distribution table is generated recording the distribution of distances from the nose of the object to the measuring device for each reflected pulse; and
an average distance to a desired stopping position is calculated.

SUBSTITUTE SHEET (RULE 26)

32. The tracking system of claims 27-31 wherein
the average distance to the stopping position is calculated by averaging the
distance to said stopping position recorded for the entries in the comparison
table corresponding to the two adjacent entries in the distance distribution
5 table having the largest sum.
33. The tracking system of claims 27-32 wherein a display shows the distance from
the object to the stopping point, the type of object and the location of the object compared
to center.
34. The tracking system of claims 27-33 wherein the average stopping distance is
10 communicated to a computer on board the aircraft allowing that computer to stop the
aircraft when said aircraft reaches said stopping position.
35. A method for verifying the shape of a detected object comprising:
projecting light pulses in angular coordinates onto an object;
reflecting said pulses back to a detector and determining the detected shape of the
15 object based on said reflected pulses;
comparing said detected shape with a profile corresponding to the shape of a
known object; and
determining whether said detected shape corresponds to said known shape.
36. The method of claim 35 wherein the profile corresponding to the shape of a
20 known object comprises sets of expected reflected pulses at various distances from the
stopping point.
37. The method of claim 35-36 wherein a microprocessor is programmed to identify
an object.

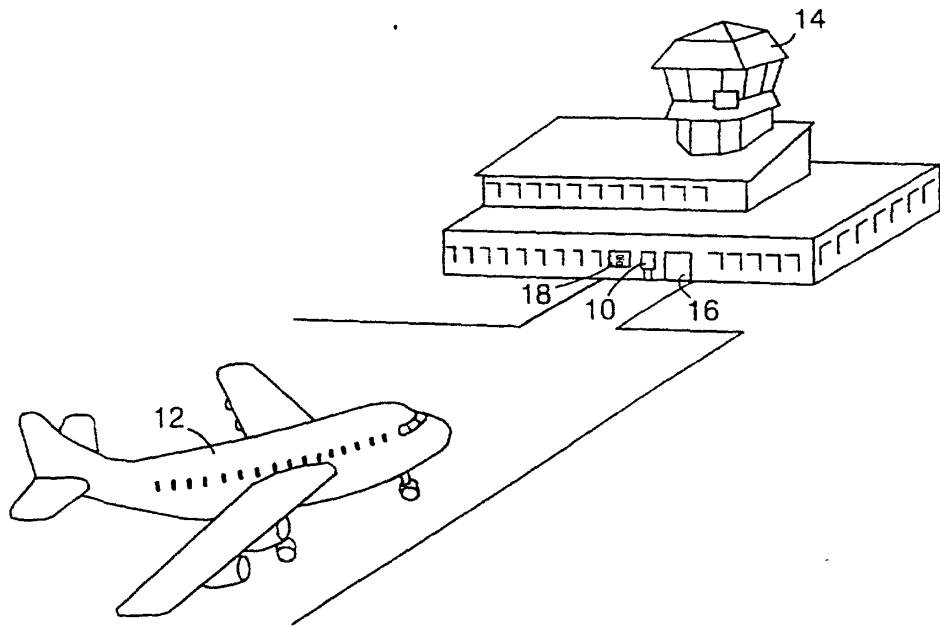

FIG.1

SUBSTITUTE SHEET (RULE 26)

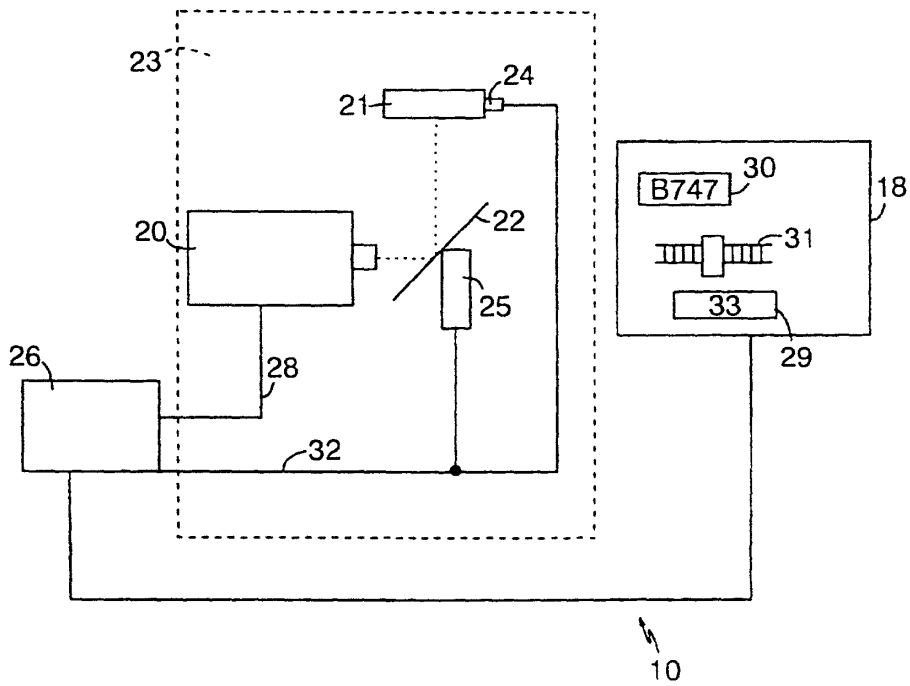

FIG.2

SUBSTITUTE SHEET (RULE 26)

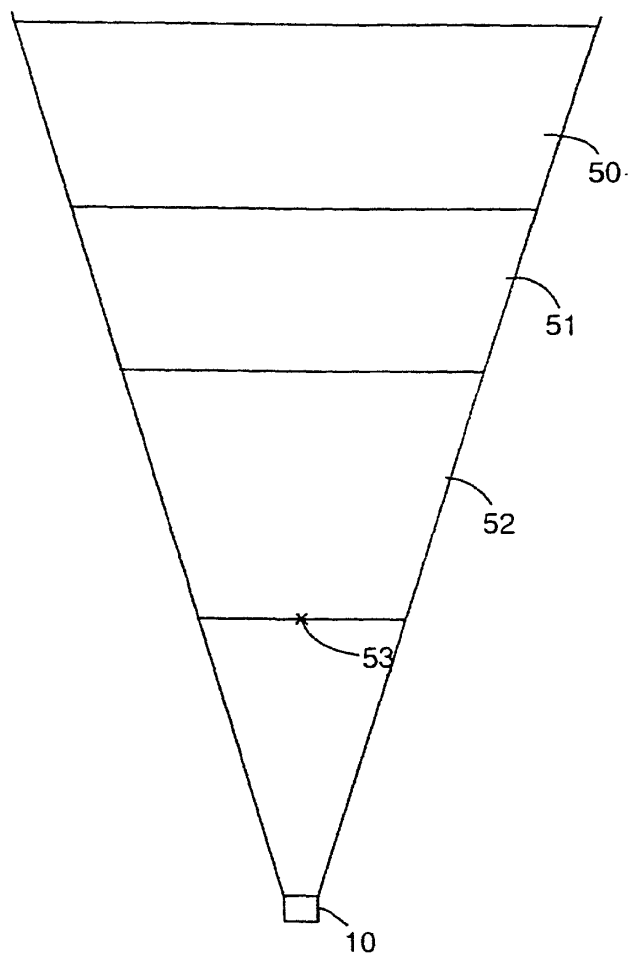
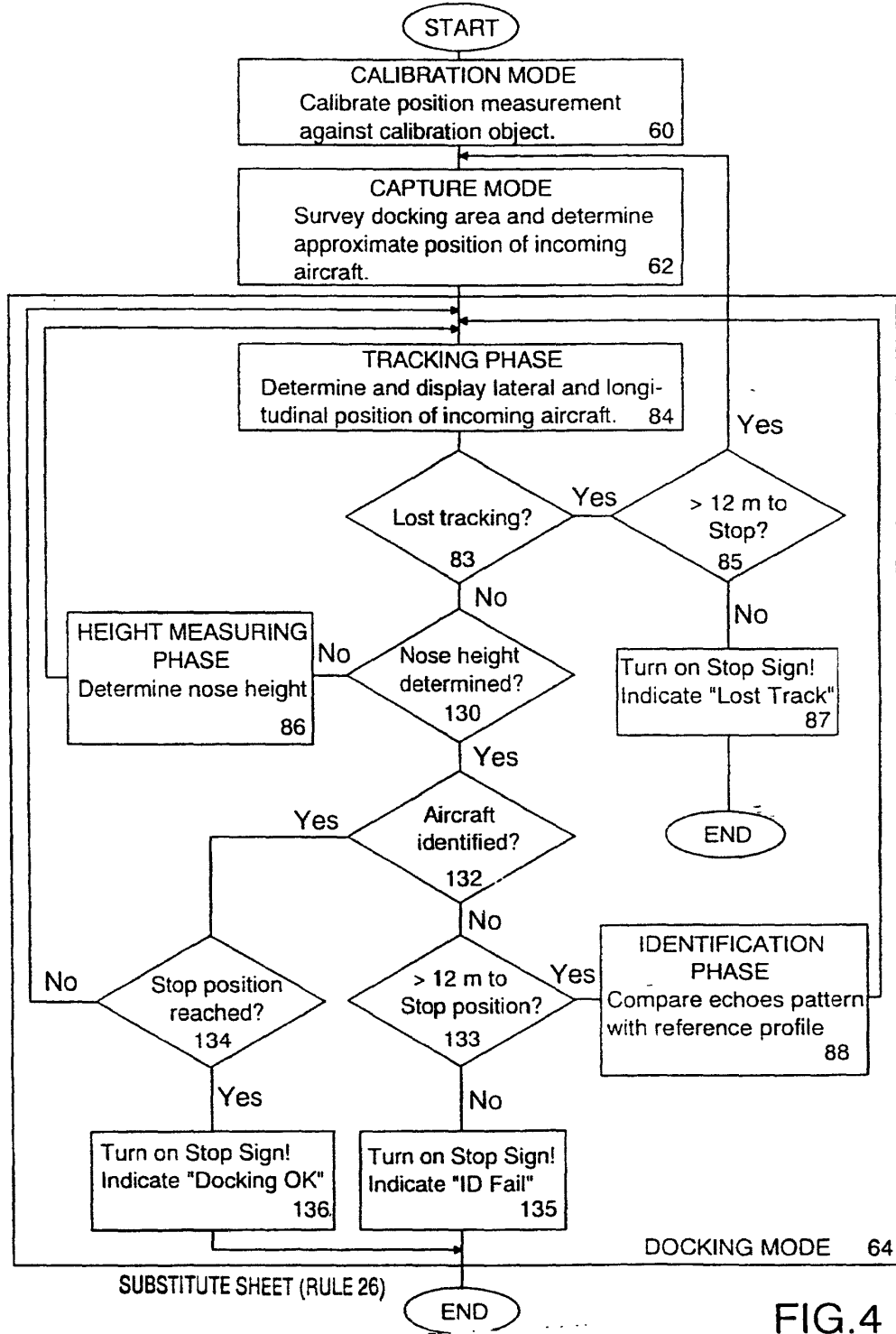

FIG.3

SUBSTITUTE SHEET (RULE 26)

4/10



SUBSTITUTE SHEET (RULE 26)

SUBSTITUTE SHEET (RULE 26)

FIG.4

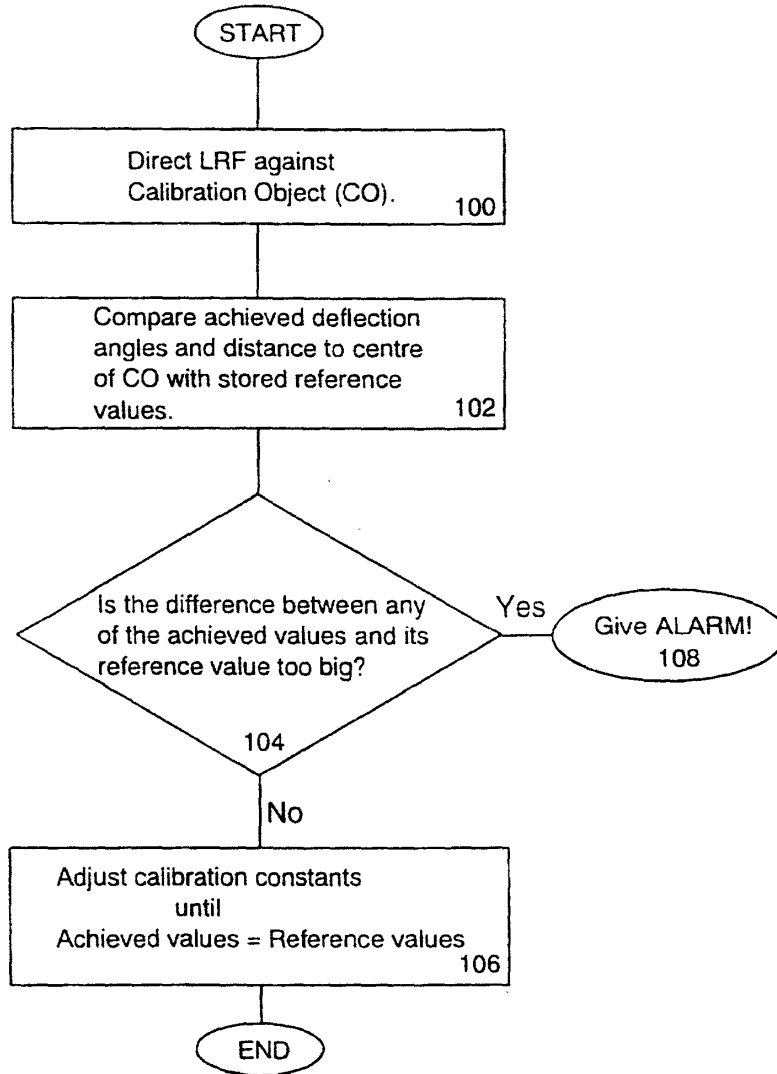

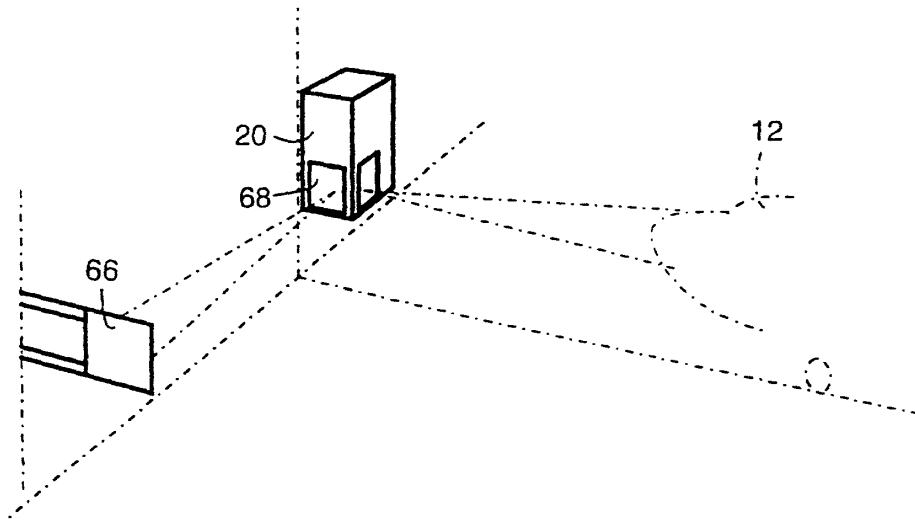
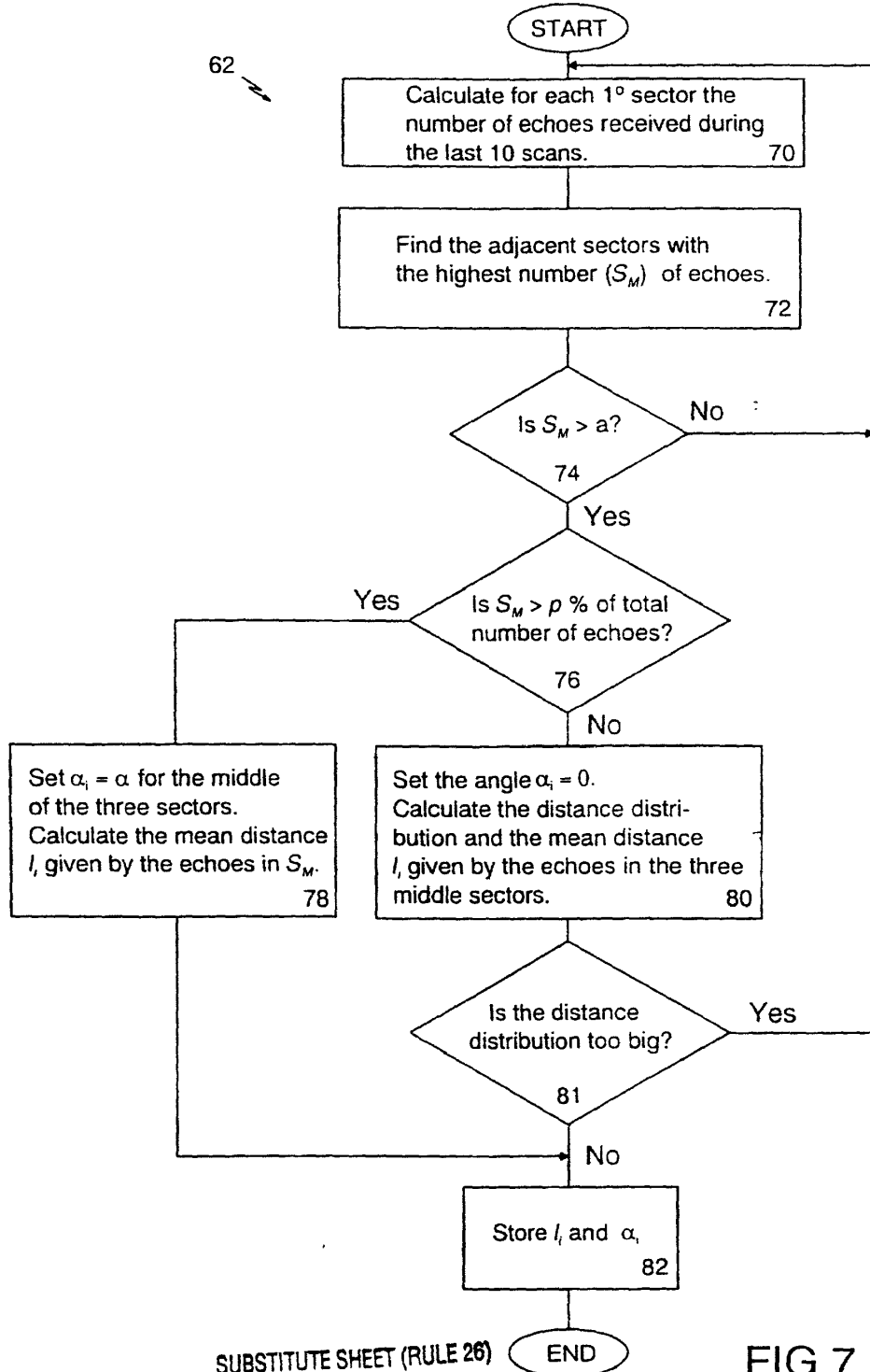

FIG.6

SUBSTITUTE SHEET (RULE 26)

7/10



SUBSTITUTE SHEET (RULE 26)

FIG.7

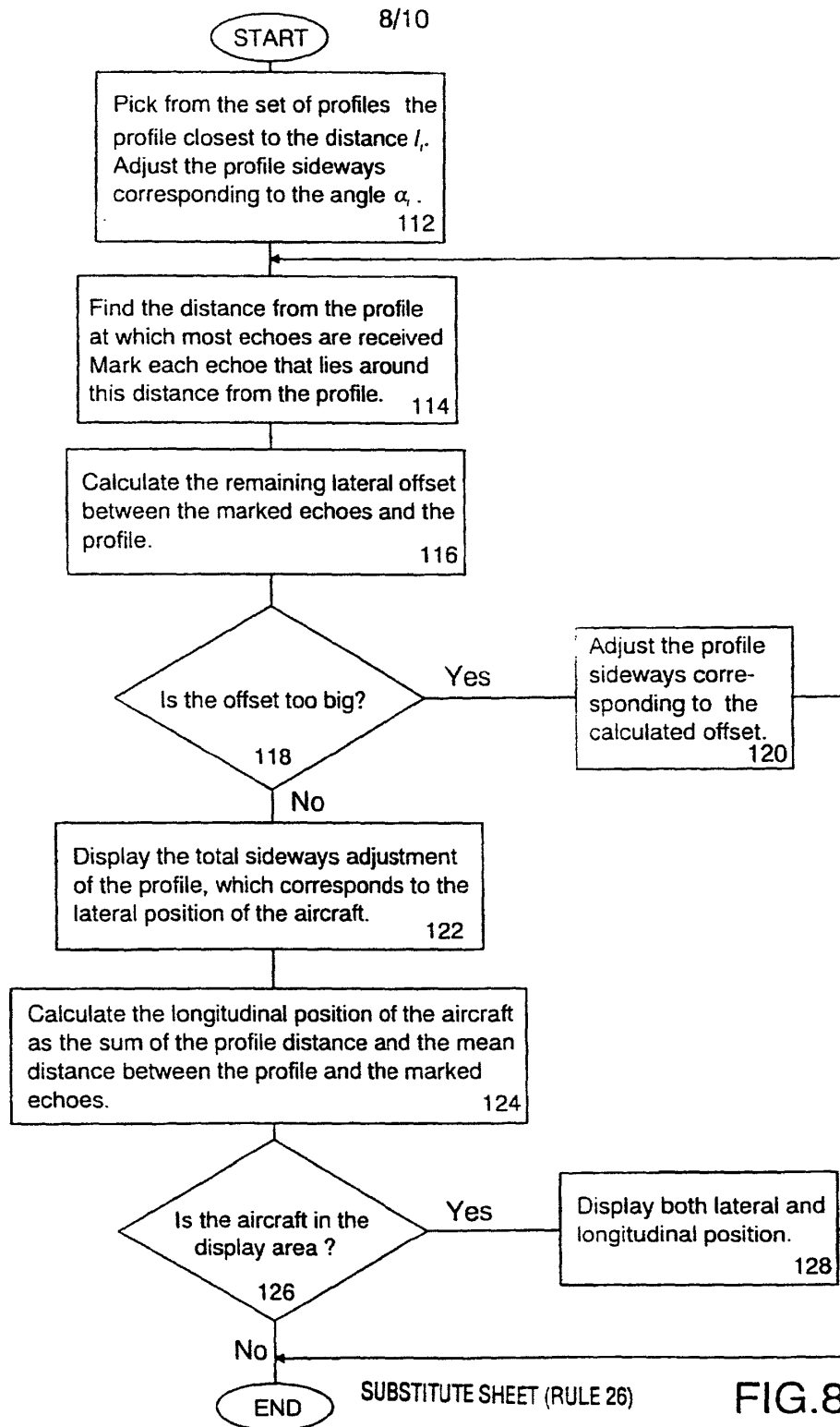

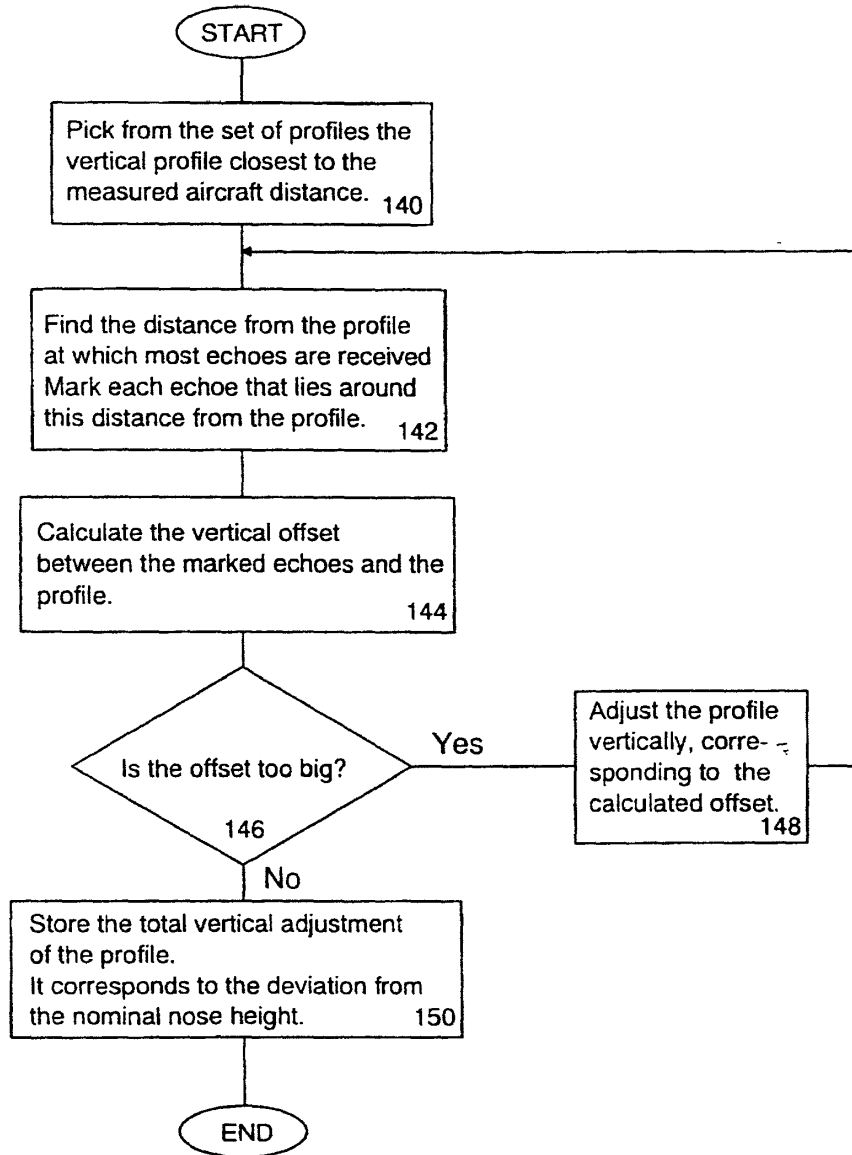

10/10

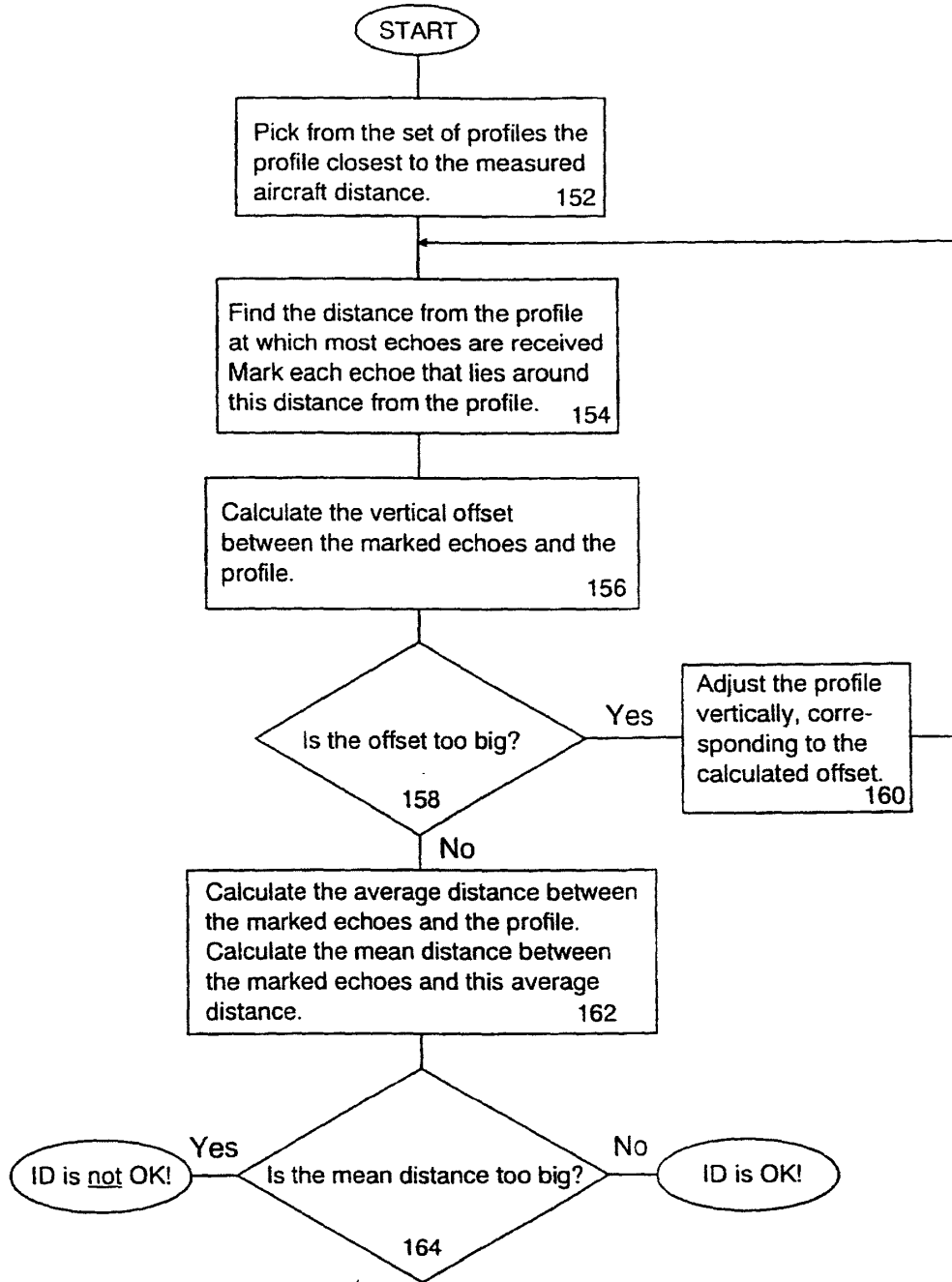

SUBSTITUTE SHEET (RULE 26)

FIG. 10

INTERNATIONAL SEARCH REPORT

International Application No
PCT/SE 94/00968

<p>A. CLASSIFICATION OF SUBJECT MATTER IPC 6 G08G5/06 B64F1/00</p>		
<p>According to International Patent Classification (IPC) or to both national classification and IPC</p>		
<p>B. FIELDS SEARCHED</p>		
<p>Minimum documentation searched (classification system followed by classification symbols) IPC 6 G08G G08B B64F</p>		
<p>Documentation searched other than minimum documentation to the extent that such documents are included in the fields searched</p>		
<p>Electronic data base consulted during the international search (name of data base and, where practical, search terms used)</p>		
<p>C. DOCUMENTS CONSIDERED TO BE RELEVANT</p>		
Category *	Citation of document, with indication, where appropriate, of the relevant passages	Relevant to claim No.
X	DE,A,43 01 637 (DEUTSCHE AEROSPACE AG) 11 August 1994 see the whole document ---	1-11,13, 16,17, 25-30, 33,35-37
X	US,A,4 319 332 (MEHNERT) 9 March 1982	1-6,13, 16,18, 25-30, 35-37
A	see column 6, line 25 - line 45; figures 1,2 see column 8, line 15 - line 29 see column 11, line 14 - column 16, line 8; figures 5,6 see abstract; claims --- -/--	7,8,10, 11,33
<p><input checked="" type="checkbox"/> Further documents are listed in the continuation of box C. <input checked="" type="checkbox"/> Patent family members are listed in annex.</p>		
<p>* Special categories of cited documents :</p>		
<p>"A" document defining the general state of the art which is not considered to be of particular relevance</p> <p>"E" earlier document but published on or after the international filing date</p> <p>"L" document which may throw doubts on priority claim(s) or which is cited to establish the publication date of another citation or other special reason (as specified)</p> <p>"O" document referring to an oral disclosure, use, exhibition or other means</p> <p>"P" document published prior to the international filing date but later than the priority date claimed</p>		<p>"T" later document published after the international filing date or priority date and not in conflict with the application but cited to understand the principle or theory underlying the invention</p> <p>"X" document of particular relevance; the claimed invention cannot be considered novel or cannot be considered to involve an inventive step when the document is taken alone</p> <p>"Y" document of particular relevance; the claimed invention cannot be considered to involve an inventive step when the document is combined with one or more other such documents, such combination being obvious to a person skilled in the art.</p> <p>"&" document member of the same patent family</p>
<p>Date of the actual completion of the international search 16 June 1995</p>		<p>Date of mailing of the international search report 22. 06. 95</p>
<p>Name and mailing address of the ISA European Patent Office, P.B. 5818 Patentlaan 2 NL - 2280 HV Rijswijk Tel. (+31-70) 340-2040, Tx. 31 651 epo nl, Fax: (+31-70) 340-3016</p>		<p>Authorized officer Reekmans, M</p>

INTERNATIONAL SEARCH REPORT

International Application No
PCT/SE 94/00968

C.(Continuation) DOCUMENTS CONSIDERED TO BE RELEVANT		
Category *	Citation of document, with indication, where appropriate, of the relevant passages	Relevant to claim No.
A	DE,A,40 09 668 (SIEMENS AG) 2 October 1991 see the whole document ---	7,8,10, 11,33
A	EP,A,0 035 101 (ELTRO GMBH GESELLSCHAFT FÜR STRAHLUNGSTECHNIK) 9 September 1981 see the whole document ---	2,4-6,9, 10
A	DATABASE WPI Section EI, Week 9332 Derwent Publications Ltd., London, GB; Class S02, AN 93-256658 & SU,A,1 753 273 (URALS EXPER MECH WKS) , 7 August 1992 see abstract ---	2,4-6,9
E	DATABASE WPI Section EI, Week 9514 Derwent Publications Ltd., London, GB; Class T04, AN 95-105467 & SE,A,9 301 843 (GUSTAVSSON K) , 13 December 1994 see abstract -----	1,4-8, 35,37

INTERNATIONAL SEARCH REPORT

Information on patent family members

International Application No
PCT/SE 94/00968

Patent document cited in search report	Publication date	Patent family member(s)	Publication date
DE-A-4301637	11-08-94	NONE	
US-A-4319332	09-03-82	DE-A- 2818942 AU-B- 525309 AU-A- 4659879 CH-A- 641583 FR-A, B 2424594 GB-A, B 2021893 JP-A- 54143097 NL-A- 7902139 SE-A- 7903699	08-11-79 28-10-82 01-11-79 29-02-84 23-11-79 05-12-79 07-11-79 30-10-79 29-10-79
DE-A-4009668	02-10-91	NONE	
EP-A-35101	09-09-81	DE-A- 3007893	10-09-81



INTERNATIONAL APPLICATION PUBLISHED UNDER THE PATENT COOPERATION TREATY (PCT)

<p>(51) International Patent Classification ⁶ : G01V 1/00, G01H 3/08</p>	<p>A1</p>	<p>(11) International Publication Number: WO 95/27910 (43) International Publication Date: 19 October 1995 (19.10.95)</p>
<p>(21) International Application Number: PCT/GB95/00820 (22) International Filing Date: 10 April 1995 (10.04.95) (30) Priority Data: 9407091.9 9 April 1994 (09.04.94) GB (71) Applicant (for all designated States except US): CIRRUS RESEARCH PLC [GB/GB]; Acoustic House, Hunmanby, North Yorkshire YO14 0PH (GB). (72) Inventor; and (75) Inventor/Applicant (for US only): WALLIS, Dudley [GB/GB]; Daytona, Station Road, Crossgates, Scarborough YO12 4LT (GB). (74) Agent: TUNSTALL, Christopher, Stephen; Dibb Lupton Broomhead, 117 The Headrow, Leeds, West Yorkshire LS1 5JX (GB).</p>	<p>(81) Designated States: AM, AT, AU, BB, BG, BR, BY, CA, CH, CN, CZ, DE, DK, EE, ES, FI, GB, GE, HU, IS, JP, KE, KG, KP, KR, KZ, LK, LR, LT, LU, LV, MD, MG, MN, MW, MX, NO, NZ, PL, PT, RO, RU, SD, SE, SG, SI, SK, TJ, TM, TT, UA, UG, US, UZ, VN, European patent (AT, BE, CH, DE, DK, ES, FR, GB, GR, IE, IT, LU, MC, NL, PT, SE), OAPI patent (BF, BJ, CF, CG, CI, CM, GA, GN, ML, MR, NE, SN, TD, TG), ARIPO patent (KE, MW, SD, SZ, UG). Published <i>With international search report. Before the expiration of the time limit for amending the claims and to be republished in the event of the receipt of amendments.</i></p>	

(54) Title: AIRPORT NOISE MONITORING SYSTEM

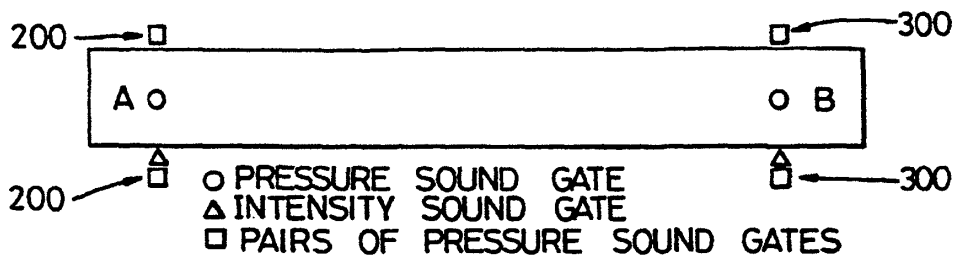

(57) Abstract

An airport noise monitoring system is disclosed comprising a pair of sound detectors (200, 300) installed in and spaced along a runway. A CPU monitors the output of each sound detector so as to recognize an output form from one (200) of the detectors characteristic of an aircraft flying overhead. A flag is assigned to any event giving rise to such an output form indicating the direction of motion of the aircraft, depending on the sound profile from the detector (300) other than the one providing the characteristic output form, and also indicating whether the aircraft is landing, taking off or flying by. Accurate timing and direction information may be obtained and accurately correlated with noise events detected around the airport, to identify noisy flights or carriers.

FOR THE PURPOSES OF INFORMATION ONLY

Codes used to identify States party to the PCT on the front pages of pamphlets publishing international applications under the PCT.

AT	Austria	GB	United Kingdom	MR	Mauritania
AU	Australia	GE	Georgia	MW	Malawi
BB	Barbados	GN	Guinea	NE	Niger
BE	Belgium	GR	Greece	NL	Netherlands
BF	Burkina Faso	HU	Hungary	NO	Norway
BG	Bulgaria	IE	Ireland	NZ	New Zealand
BJ	Benin	IT	Italy	PL	Poland
BR	Brazil	JP	Japan	PT	Portugal
BY	Belarus	KE	Kenya	RO	Romania
CA	Canada	KG	Kyrgyzstan	RU	Russian Federation
CF	Central African Republic	KP	Democratic People's Republic of Korea	SD	Sudan
CG	Congo	KR	Republic of Korea	SE	Sweden
CH	Switzerland	KZ	Kazakhstan	SI	Slovenia
CI	Côte d'Ivoire	LI	Liechtenstein	SK	Slovakia
CM	Cameroon	LK	Sri Lanka	SN	Senegal
CN	China	LU	Luxembourg	TD	Chad
CS	Czechoslovakia	LV	Latvia	TG	Togo
CZ	Czech Republic	MC	Monaco	TJ	Tajikistan
DE	Germany	MD	Republic of Moldova	TT	Trinidad and Tobago
DK	Denmark	MG	Madagascar	UA	Ukraine
ES	Spain	ML	Mali	US	United States of America
FI	Finland	MN	Mongolia	UZ	Uzbekistan
FR	France			VN	Viet Nam
GA	Gabon				

AIRPORT NOISE MONITORING SYSTEM

This invention relates to airport noise monitoring systems, i.e. noise monitoring systems which are adapted to distinguish aircraft from other noise events. Once a noise event is attributed to an aircraft, the aircraft is identified from other information, which enables the carrier to be fined if the noise level exceeds an acceptable noise level.

Background to the invention

10 Airport noise monitoring systems commonly include a number of noise monitoring terminals distributed in and around the airport. Most current airport noise monitors use the technique of "Short Leq" for the acquisition of data, usually based upon a 62.5 ms long basic integration period.

15 Short Leq allows the system to recognize an individual flight by its time history. Of course, not all noise monitoring terminals have a sufficiently good signal-to-noise ratio and in practice, many noise events are lost amongst other noise sources such as heavy vehicles or

20 industrial plant. One measure of the efficiency of an aircraft noise monitoring system is how well it recovers signals in noisy conditions.

Cirrus Research plc produces a noise monitoring terminal which uses efficient aircraft-recognition algorithms. The algorithms are described in A. D. Wallis & R. W. Krug, "The Sydney and Brisbane Noise Terminals", Proc. WESTPRAC, pp. 492-499, Nov. 1991 and basically consist of multiple threshold detection with specified event durations.

30 Experience has proven that this complex nine-parameter algorithm will recognise some 99% of scheduled or military aircraft correctly. In common with all systems, the Cirrus system does have a lower success rate for very quiet aircraft or in areas of high background noise.

35 With 100 flights per day, the system described above may incorrectly identify one flight per day and thus, before the noise events can be assigned to individual aircraft,

something else must be brought in to reduce this recognition error rate, since at a major airport with over 1000 flights per day, even a 99% success rate is unacceptable.

5

Each airport has access to flight information - as displayed on the internal information boards - and this is often used as one of the correlation parameters in identification. However, if the airport has significant
10 general aviation or private traffic, this information will be incomplete and significant events such as jet test flights will not be included. Thus, knowing that a noise event has taken place and that there was an incoming or outgoing flight at a similar time is still not adequate to
15 enable the two to be correlated with a sufficient degree of confidence. The flight information data must be tied to a particular noise event with no significant possibility of error.

20 Summary of the invention

According to the present invention, a true take-off or landing time is attributed to each flight by appropriate sound detectors, and whether the aircraft is taking off or landing is recognised. An airport noise monitoring system
25 according to the present invention comprises a pair of sound detectors to be installed in or on and spaced along a runway and means for monitoring the output of each sound detector so as to recognize an output form from either one of the detectors characteristic of an aircraft flying
30 overhead, checking the output from the other sound detector representing time prior to and subsequent to the event giving rise to the characteristic output form for an output form indicative of the proximity of an aircraft and consequently assigning to the event a flag indicative of
35 the direction of motion of the aircraft and whether it is taking off, flying by or landing. The output form from either of the detectors characteristic of an aircraft flying overhead may be recognized by the nine-parameter algorithm as discussed above.

Having sound detectors placed in or on the runway and recognizing and timing the passage of aircraft provides accurate information as to take-off or landing times, which may then be correlated with noise events detected by monitoring terminals elsewhere with a reasonable degree of certainty. The data from the sound detectors are now used in place of the airport flight time information to give a good event definition and only then is the flight time information added to enable individual flights to be recognised. In effect, the flight time information is required only to indicate the order in which the aircraft take off or land, rather than the exact time.

Preferably, the means for monitoring, checking and assigning is adapted to assign to the event a flag indicating that the direction of motion of the aircraft is away from the said one sound detector and towards the said other sound detector when the output from the said other sound gate includes an output form indicative of the proximity of an aircraft within a predetermined window of time subsequent to the event. Further, the means for monitoring, checking and assigning is preferably adapted to assign to the event a flag indicating that the aircraft is landing when the said output form indicative of the proximity of an aircraft is not characteristic of an aircraft flying overhead. When the said output form indicative of the proximity of an aircraft is characteristic of an aircraft flying overhead, the means for monitoring, checking and assigning will preferably assign to the event a flag indicating that the aircraft is flying by. The output form indicative of the proximity of an aircraft may be any output exceeding a predetermined noise level.

Similarly, the means for monitoring, checking and assigning is preferably adapted to assign to the event a flag indicating that the direction of motion of the aircraft is towards the said one sound detector and away from the said other sound detector when the output from the said other

sound gate includes an output form indicative of the proximity of an aircraft within a predetermined window of time prior to the event. Further, the means for monitoring, checking and assigning is preferably adapted to
5 assign to the event a flag indicating that the aircraft is taking off when the said output form indicative of the proximity of an aircraft is not characteristic of an aircraft flying overhead. Any output from the said other
10 sound detector which has already been taken into account in assigning a flag indicative of the direction of motion of an aircraft giving rise to a previous event will preferably be disregarded by the means for monitoring, checking and assigning.

15 The noise monitoring system may further include a plurality of further sound detectors to be distributed in or around the airport and including means for monitoring the output of each noise detector so as to recognize an output form characteristic of an aircraft flying overhead and for
20 correlating the events and flags recognized and assigned by the means for monitoring, checking and assigning with events giving rise to the characteristic output forms recognized by the means for monitoring the output of each further sound detector.

25 The means for monitoring the output of each further sound detector and/or the means for monitoring, checking and assigning may comprise one or more suitably programmed microprocessors.

30 The present invention also extends to a method of detecting an aircraft comprising monitoring the output of each of a pair of sound detectors installed in or on and spaced along a runway so as to recognize an output form from either one
35 of the detectors characteristic of an aircraft flying overhead, checking the output from the other sound detector representing time prior to and subsequent to the event giving rise to the characteristic output form for an output form indicative of the proximity of an aircraft and

assigning to an event giving rise to such a characteristic output form a flag indicative of the direction of motion of the aircraft and whether it is taking off, flying by or landing in dependence upon the output from the said other
5 sound detector.

The method may include checking the output from the said other sound detector within a predetermined window of time subsequent to the event and assigning to the event a flag
10 indicating that the direction of motion of the aircraft is away from the said one sound detector and towards the said other sound detector if that output includes an output form indicative of the proximity of an aircraft. In these
15 circumstances, the method preferably includes assigning to the event a flag indicating that the aircraft is landing if the said output form indicative of the proximity of an aircraft is not characteristic of an aircraft flying overhead. Further, the method preferably includes
20 assigning to the event a flag indicating that the aircraft is flying by if the said output form indicative of the proximity of an aircraft is characteristic of an aircraft flying overhead.

The method may include checking the output from the said
25 other sound detector within a predetermined window of time prior to the event and assigning to the event a flag indicating that the direction of motion of the aircraft is towards the said one sound detector and away from the said other sound detector if that output includes an output form
30 indicative of the proximity of an aircraft. In these circumstances, the method preferably includes assigning to the event a flag indicating that the aircraft is taking off if the said output form indicative of the proximity of an aircraft is not characteristic of an aircraft flying
35 overhead. Preferably, any output from the said other sound detector which has already been taken into account in assigning a flag indicative of the direction of motion of an aircraft giving rise to a previous event is disregarded.

The method may further include monitoring the output of each of a plurality of further sound detectors distributed in or around the airport so as to recognize an output form characteristic of an aircraft flying overhead and correlating the events and flags recognized and assigned by monitoring and checking the outputs of the said pair of sound detectors with events giving rise to the characteristic output forms recognized by monitoring the output of each further sound detector.

The monitoring of the output of each further sound detector and/or the monitoring and checking of the output of the said pair of sound detectors and consequent assignment of flags may be accomplished by one or more suitably programmed microprocessors.

Brief description of the drawings

The present invention will now be described by way of example with reference to the accompanying drawings in which:

Fig. 1 illustrates a simple sound detector with one pressure transducer;

Fig. 2 illustrates a more complex sound detector with provision for intensity measurement;

Fig. 3 is a schematic illustration of a runway with sound detectors installed;

Fig. 4 is a schematic illustration of the output from the two sound detectors when an aircraft is taking off; and

Fig. 5 is a corresponding illustration when the aircraft is landing.

Detailed description

The simple noise detector 10 illustrated in fig. 1 includes a pressure transducer 12, which in this example is a microphone. The output from the microphone is passed through a band-pass filter 14, which removes unwanted frequencies, leaving those which are generated by aircraft engines and provide the highest signal-to-noise ratio. The filtered signal then passes through a squarer 16 and is integrated by an integrator 18, operating over a 62.5 ms cycle, to provide a series of pulses representing the mean square average sound level during the preceding 62.5 ms. These pulses are digitised and stored in a memory or store 20 to be processed by a CPU 22 as described.

A more complex noise detector 110 is illustrated in fig. 2, including a pair of microphones 112, 114. The signals from the microphones are summed at 116 and 118, with one summation circuit 118 having the output from one microphone 114 inverted by inverter 120, thus outputting the difference between the two microphone signals. The signals pass through respective band-pass filters 122, 124 as described above and are then processed by an integrator 126, a pre-processor 128 and a CPU 130 to yield intensity, sound power and directionality information in the usual way. Again, a series of digitised pulses is stored in a memory or store 132 to be processed by a suitably programmed CPU 134.

Fig. 3 illustrates schematically the placement of the sound detectors on a runway. As can be seen, one sound detector 200 or possibly a pair of sound detectors 200 is placed at one end A of the runway and another sound detector 300 or pair of sound detectors 300 is placed at the other end B. Where a single detector is emplaced at each end of the runway, it is preferred that it be embedded in the runway surface. The separate detectors 200; 300 or pairs of detectors 200; 300 are able by virtue of their spacing along the runway to resolve the position of the aircraft at various times as it flies overhead and therefore determine its direction of flight.

Fig. 4 illustrates diagrammatically a typical output from two sound detectors 200; 300 positioned at points A and B on or in the runway when an aircraft is taking off in the direction A-B. As the aircraft taxis into place at one and
5 A of the runway, the associated sound detector 200 detects the increased level of sound. However, the character of the sound detected by this detector 200 is quite different from that attributable to an aircraft passing overhead and accordingly, the sound level is simply stored in memory for
10 future reference. As the aircraft begins its run along the runway, the sound level detected by the detector 200 diminishes with a characteristic slope. Although this slope could be used as a trigger for an attributable event, this is not preferred owing to inherent differences in the
15 take-off patterns of various aircraft and flights and the fact that incoming aircraft could be mistaken for aircraft beginning their take-off. Rather, the characteristically diminishing sound level is again stored for future reference.

20
Once the aircraft has travelled sufficiently far down the runway, it takes off and subsequently passes over the second sound detector 300. The output from this detector 300 will have a form characteristic of an aircraft flying
25 overhead and will be recognised as such by the processing electronics, i.e. the microprocessor. The recognition algorithm is as described above. Once this characteristic form has been recognised, the CPU will refer back to the stored sound levels from the first detector 200 within a
30 predetermined window of time preceding the event at the second detector 300 and in doing so will encounter the high level of sound terminating in a characteristic slope. This will be recognised as indicating the presence of an aircraft at the first detector 200, and perhaps even the
35 fact that it is beginning its take-off. Accordingly, this event will be timed and flagged as a take-off in the direction A-B.

Fig. 5 illustrates diagrammatically a typical output from two sound detectors 200; 300 positioned at points A and B on or in the runway when an aircraft is landing in the direction A-B. As the aircraft passes over the first sound detector 200, the output from this detector 200 will have a form characteristic of an aircraft flying overhead and will be recognised as such by the processing electronics, i.e. the microprocessor. Again, the recognition algorithm is as described above. Once this characteristic form has been recognised, the CPU will refer back to stored sound levels from the second detector 300 within a predetermined window of time preceding the event at the second detector 300 and in doing so will be unable to identify a high level of sound, which has not already been attributed to a previous event, indicating the presence of an aircraft at the second detector 300. Accordingly, the CPU will wait until the beginning of predetermined window of time and then inspect the output from the second detector.

After landing, the aircraft will run or taxi by the second detector 300, which detects the increased level of sound. The character of the sound detected by this detector 300 is quite different from that attributable to an aircraft passing overhead and accordingly, provided this sound level coincides with the window of time following the event at the first detector 200, this event will be timed and flagged as a landing in the direction A-B. In the unlikely event that both detectors show characteristic forms attributable to an aircraft flying overhead within the predetermined window of time from one another, the event will be flagged as a fly-by or abortive landing in the relevant direction.

Once the take-offs and landings are accurately timed and flagged, they may be correlated with high confidence levels with noise events detected by other noise monitoring stations in and around the airport, and the flights in question identified from airport information which is used

to determine the order in which particular flights took off
and landed.

CLAIMS

1. An airport noise monitoring system comprising a pair
of sound detectors to be installed in or on and spaced
5 along a runway and means for monitoring the output of
each sound detector so as to recognize an output form
from either one of the detectors characteristic of an
aircraft flying overhead, checking the output from the
10 other sound detector representing time prior to and
subsequent to the event giving rise to the
characteristic output form for an output form
indicative of the proximity of an aircraft and
consequently assigning to the event a flag indicative
15 of the direction of motion of the aircraft and whether
it is taking off, flying by or landing.
2. A noise monitoring system according to claim 1 in
which the means for monitoring, checking and assigning
20 is adapted to assign to the event a flag indicating
that the direction of motion of the aircraft is away
from the said one sound detector and towards the said
other sound detector when the output from the said
other sound gate includes an output form indicative of
25 the proximity of an aircraft within a predetermined
window of time subsequent to the event.
3. A noise monitoring system according to claim 2 in
which the means for monitoring, checking and assigning
30 is adapted to assign to the event a flag indicating
that the aircraft is landing when the said output form
indicative of the proximity of an aircraft is not
characteristic of an aircraft flying overhead.
4. A noise monitoring system according to claim 2 or
35 claim 3 in which the means for monitoring, checking
and assigning is adapted to assign to the event a flag
indicating that the aircraft is flying by when the
said output form indicative of the proximity of an

aircraft is characteristic of an aircraft flying overhead.

5. A noise monitoring system according to any preceding claim in which the means for monitoring, checking and assigning is adapted to assign to the event a flag indicating that the direction of motion of the aircraft is towards the said one sound detector and away from the said other sound detector when the output from the said other sound gate includes an output form indicative of the proximity of an aircraft within a predetermined window of time prior to the event.
6. A noise monitoring system according to claim 5 in which the means for monitoring, checking and assigning is adapted to assign to the event a flag indicating that the aircraft is taking off when the said output form indicative of the proximity of an aircraft is not characteristic of an aircraft flying overhead.
7. A noise monitoring system according to claim 5 or claim 6 in which the means for monitoring, checking and assigning is adapted to disregard any output from the said other sound detector which has already been taken into account in assigning a flag indicative of the direction of motion of an aircraft giving rise to a previous event.
8. A noise monitoring system according to any preceding claim further including a plurality of further sound detectors to be distributed in or around the airport and including means for monitoring the output of each noise detector so as to recognize an output form characteristic of an aircraft flying overhead and for correlating the events and flags recognized and assigned by the means for monitoring, checking and assigning with events giving rise to the characteristic output forms recognized by the means

for monitoring the output of each further sound detector.

- 5 9. A noise monitoring system according to any preceding claim in which the means for monitoring the output of each further sound detector comprises one or more suitably programmed microprocessors.
- 10 10. A noise monitoring system according to any preceding claim in which the means for monitoring, checking and assigning comprises one or more suitably programmed microprocessors.
- 15 11. A method of detecting an aircraft comprising monitoring the output of each of a pair of sound detectors installed in or on and spaced along a runway so as to recognize an output form from either one of the detectors characteristic of an aircraft flying overhead, checking the output from the other sound detector representing time prior to and subsequent to the event giving rise to the characteristic output form for an output form indicative of the proximity of an aircraft and assigning to an event giving rise to such a characteristic output form a flag indicative of the direction of motion of the aircraft and whether it is taking off, flying by or landing in dependence upon the output from the said other sound detector.
- 20 25 12. A method according to claim 11 including checking the output from the said other sound detector within a predetermined window of time subsequent to the event and assigning to the event a flag indicating that the direction of motion of the aircraft is away from the said one sound detector and towards the said other sound detector if that output includes an output form indicative of the proximity of an aircraft.
- 30 35 13. A method according to claim 12 including assigning to the event a flag indicating that the aircraft is

landing if the said output form indicative of the proximity of an aircraft is not characteristic of an aircraft flying overhead.

- 5 14. A method according to claim 12 or claim 13 including assigning to the event a flag indicating that the aircraft is flying by if the said output form indicative of the proximity of an aircraft is characteristic of an aircraft flying overhead.
- 10 15. A method according to any one of claims 11-14 including checking the output from the said other sound detector within a predetermined window of time prior to the event and assigning to the event a flag indicating that the direction of motion of the aircraft is towards the said one sound detector and away from the said other sound detector if that output includes an output form indicative of the proximity of an aircraft.
- 15 16. A method according to claim 15 including assigning to the event a flag indicating that the aircraft is taking off if the said output form indicative of the proximity of an aircraft is not characteristic of an aircraft flying overhead.
- 20 17. A method according to claim 15 or claim 16 in which any output from the said other sound detector which has already been taken into account in assigning a flag indicative of the direction of motion of an aircraft giving rise to a previous event is disregarded.
- 25 18. A method according to any one of claims 11-17 further including monitoring the output of each of a plurality of further sound detectors distributed in or around the airport so as to recognize an output form characteristic of an aircraft flying overhead and correlating the events and flags recognized and
- 30
- 35

assigned by monitoring and checking the outputs of the said pair of sound detectors with events giving rise to the characteristic output forms recognized by monitoring the output of each further sound detector.

5

19. A method according to claim 18 in which the monitoring of the output of each further sound detector is accomplished by one or more suitably programmed microprocessors.

10

20. A method according to any one of claims 10-19 in which the monitoring and checking of the output of the said pair of sound detectors and consequent assignment of flags is accomplished by one or more suitably programmed microprocessors.

15

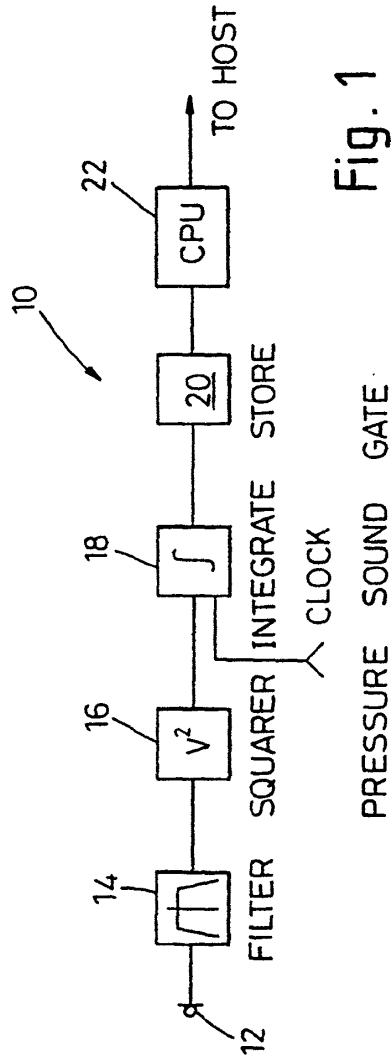

Fig. 1

1/2

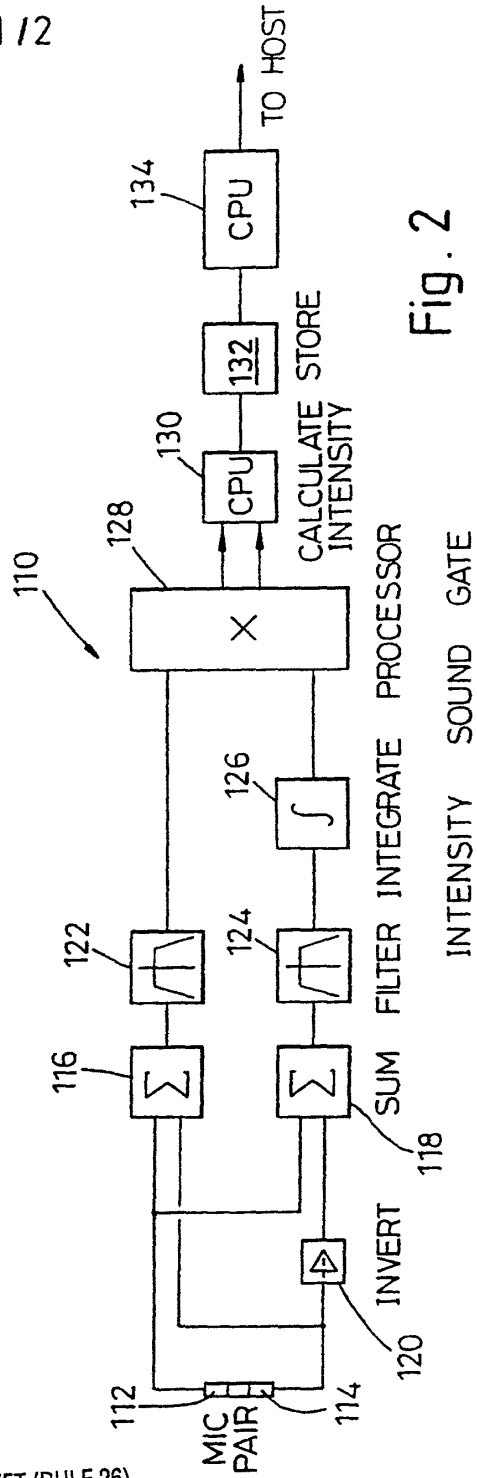

Fig. 2

SUBSTITUTE SHEET (RULE 26)

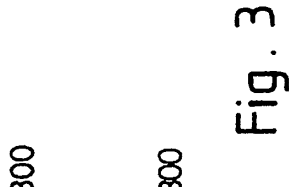

Fig. 3

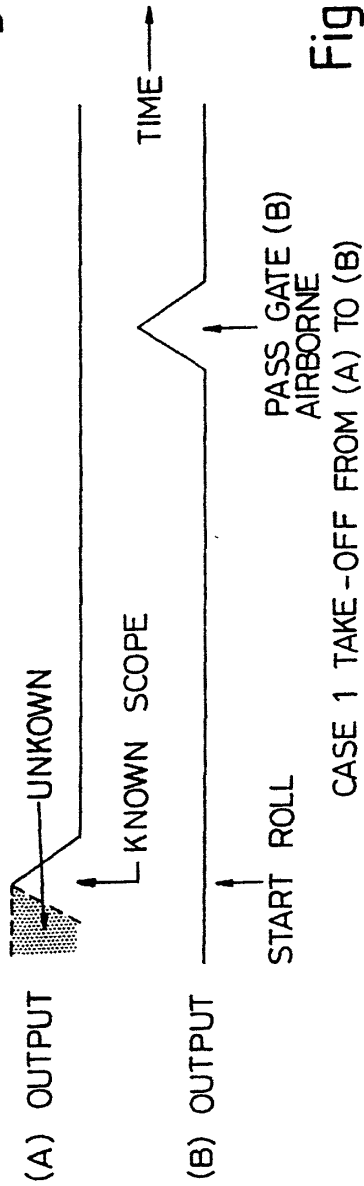

Fig. 4

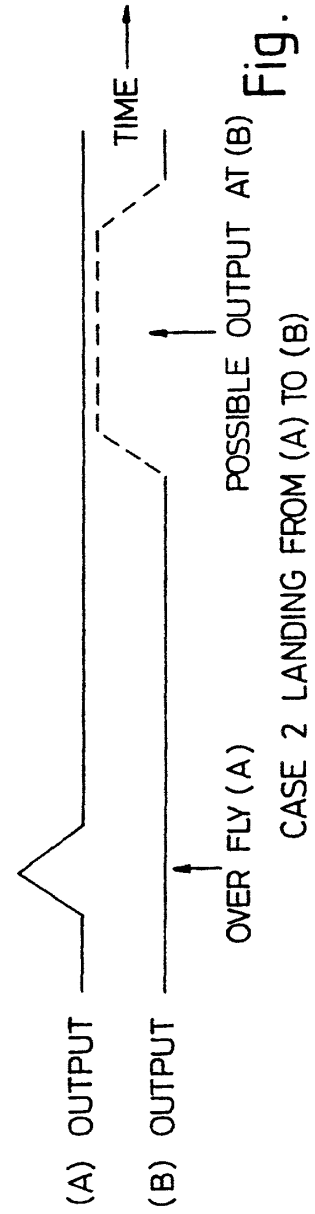

Fig. 5

SUBSTITUTE SHEET (RULE 26)

INTERNATIONAL SEARCH REPORT

International Application No
PCT/GB 95/00820

<p>A. CLASSIFICATION OF SUBJECT MATTER IPC 6 G01V1/00 G01H3/08</p> <p>According to International Patent Classification (IPC) or to both national classification and IPC</p>											
<p>B. FIELDS SEARCHED</p> <p>Minimum documentation searched (classification system followed by classification symbols) IPC 6 G01V G01H</p> <p>Documentation searched other than minimum documentation to the extent that such documents are included in the fields searched</p> <p>Electronic data base consulted during the international search (name of data base and, where practical, search terms used)</p>											
<p>C. DOCUMENTS CONSIDERED TO BE RELEVANT</p> <table border="1"> <thead> <tr> <th>Category*</th> <th>Citation of document, with indication, where appropriate, of the relevant passages</th> <th>Relevant to claim No.</th> </tr> </thead> <tbody> <tr> <td>X</td> <td>GB-A-2 235 771 (SECR DEFENCE) 13 March 1991 see abstract; claims 1,8; figure 5 ---</td> <td>1,2,5,9, 11,12</td> </tr> <tr> <td>X</td> <td>J. WIGHT, P. DE HEERING, D. BALL, S. RADHAKANT 'Development of a prototype aircraft counter- Phase I, A technical report prepared for the Transportation Development Centre, Montreal, Quebec.' December 1987, CANADIAN ASTRONAUTICS LIMITED, OTTAWA, CANADA see page 13-21 ----- -/--</td> <td>1,2,5,9</td> </tr> </tbody> </table>			Category*	Citation of document, with indication, where appropriate, of the relevant passages	Relevant to claim No.	X	GB-A-2 235 771 (SECR DEFENCE) 13 March 1991 see abstract; claims 1,8; figure 5 ---	1,2,5,9, 11,12	X	J. WIGHT, P. DE HEERING, D. BALL, S. RADHAKANT 'Development of a prototype aircraft counter- Phase I, A technical report prepared for the Transportation Development Centre, Montreal, Quebec.' December 1987, CANADIAN ASTRONAUTICS LIMITED, OTTAWA, CANADA see page 13-21 ----- -/--	1,2,5,9
Category*	Citation of document, with indication, where appropriate, of the relevant passages	Relevant to claim No.									
X	GB-A-2 235 771 (SECR DEFENCE) 13 March 1991 see abstract; claims 1,8; figure 5 ---	1,2,5,9, 11,12									
X	J. WIGHT, P. DE HEERING, D. BALL, S. RADHAKANT 'Development of a prototype aircraft counter- Phase I, A technical report prepared for the Transportation Development Centre, Montreal, Quebec.' December 1987, CANADIAN ASTRONAUTICS LIMITED, OTTAWA, CANADA see page 13-21 ----- -/--	1,2,5,9									
<p><input checked="" type="checkbox"/> Further documents are listed in the continuation of box C. <input checked="" type="checkbox"/> Patent family members are listed in annex.</p>											
<p>* Special categories of cited documents :</p> <p>*A* document defining the general state of the art which is not considered to be of particular relevance</p> <p>*E* earlier document but published on or after the international filing date</p> <p>*L* document which may throw doubts on priority claim(s) or which is cited to establish the publication date of another citation or other special reason (as specified)</p> <p>*O* document referring to an oral disclosure, use, exhibition or other means</p> <p>*P* document published prior to the international filing date but later than the priority date claimed</p> <p>*T* later document published after the international filing date or priority date and not in conflict with the application but cited to understand the principle or theory underlying the invention</p> <p>*X* document of particular relevance; the claimed invention cannot be considered novel or cannot be considered to involve an inventive step when the document is taken alone</p> <p>*Y* document of particular relevance; the claimed invention cannot be considered to involve an inventive step when the document is combined with one or more other such documents, such combination being obvious to a person skilled in the art.</p> <p>*&* document member of the same patent family</p>											
<p>Date of the actual completion of the international search 11 August 1995</p>		<p>Date of mailing of the international search report 18.08.95</p>									
<p>Name and mailing address of the ISA European Patent Office, P.B. 5818 Patentlaan 2 NL - 2280 HV Rijswijk Tel. (+31-70) 340-2040, Tx. 31 651 epo nl, Fax (+31-70) 340-3016</p>		<p>Authorized officer de Heering, P</p>									

Form PCT/ISA/210 (second sheet) (July 1992)

INTERNATIONAL SEARCH REPORT

International Application No
PCT/GB 95/00820

C.(Continuation) DOCUMENTS CONSIDERED TO BE RELEVANT		
Category	Citation of document, with indication, where appropriate, of the relevant passages	Relevant to claim No.
X	NOISE CONTROL ENGINEERING, vol. 5, no. 1, July 1975 - August 1975 USA, pages 36-40, W. K. CONNOR, B. K. COOPER 'Automatic airport noise monitoring system' Paragraph: "Aircraft detection". see page 39; figure 6 ---	1
A	US-A-3 855 571 (MASSA F) 17 December 1974 see abstract ---	1
A	PATENT ABSTRACTS OF JAPAN vol. 008 no. 179 (P-295), 17 August 1984 & JP,A,59 072028 (KOBAYASHI RIGAKU KENKYUSHO;OTHERS: 01) 23 April 1984, see abstract ---	1
A	US-A-5 189 425 (HACKEL RICHARD P ET AL) 23 February 1993 see abstract; figures 9-11 -----	8

Form PCT/ISA/210 (continuation of second sheet) (July 1992)

INTERNATIONAL SEARCH REPORT

International Application No
PCT/GB 95/00820

Patent document cited in search report	Publication date	Patent family member(s)	Publication date
GB-A-2235771	13-03-91	DE-C- 3101307 FR-A- 2712705 US-A- 5047995	22-08-91 24-05-95 10-09-91
US-A-385571	17-12-74	NONE	
US-A-5189425	23-02-93	US-A- 5075680	24-12-91

Form PCT/ISA/210 (patent family annex) (July 1992)

JP1998-155040 (Nisshin Denki ; Pub.Jun.9,1998) (JP-A-10-155040)

[Title of the Invention] CALLING METHOD OF DIAL-UP CONNECTION COMMUNICATION EQUIPMENT AND SUPERVISORY CONTROL SYSTEM USING IT

[Abstract]

[Problem] To provide a calling method, which may surely call the communication equipment connected to the Internet network by dial-up and perform two-way communication securely in real time.

[Means for Resolution] The communication equipment 2 calls the communication equipment 3 through a telephone line 4 to transmit a connection request and its own public key to the communication equipment 3. On the other hand, the communication equipment 3 transmits its own public key to the communication equipment 2. After that, both of the communication equipment 2, 3 once disconnect the telephone line 4, and call neighboring providers 5, 6 to connect the same respectively to the Internet network 7. Both of the communication equipment 2, 3, encipher their own IP addresses in the current connection by the public key of the party to transmit it as an electronic mail to the electronic mail address of the party. Each of the communication equipment 2, 3 decodes the received electronic mail by its own privacy key to confirm the IP address of the party. After that, both of the communication equipment 2, 3 communicate through the Internet network 7 using the concerned IP address.

[Claims]

[Claim 1] A calling method of dial-up connection communication equipment, which is a method of calling dial-up connection communication equipment connected to a network by dial-up, comprising: a first process in which calling communication equipment transmits a connection request to dial-up connection communication equipment by a communication line provided separately from the network and capable of calling the dial-up connection communication equipment; a second process in which the dial-up connection communication equipment receiving the connection request is connected to the network by dial-up; and a third process in which the calling communication equipment and the dial-up connection communication equipment communicate with each other through the network.

[Claim 2] The calling method of dial-up connection communication equipment according to claim 1, wherein the third process includes: an encipher process in which the transmitting communication equipment between the calling communication equipment and the dial-up connection communication equipment enciphers and transmits at least part of the data transmitted in the third process; and a decoding process in which the receiving communication equipment decodes the enciphered data.

[Claim 3] The calling method of dial-up connection communication equipment according to claim 2, wherein the first process includes a process in which the calling

communication equipment or the dial-up connection communication equipment informs the party at the other end of a key of cryptograph used in encipher.

[Claim 4] The calling method of dial-up connection communication equipment according to claim 1, 2 or 3, wherein the network is provided with a server for relaying the communication between the calling communication equipment and the dial-up connection communication equipment, and the third process includes: a process in which both of the above communication equipment inform the sever of their own identifications; a process in which both of the above communication equipment inform the server of the identification of the party at the other end to select the communication equipment of the party at the other end; and a process in which the server relays the communication between the selected communication equipment.

[Claim 5] The calling method of dial-up connection communication equipment according to claim 1, 2 or 3, wherein the network is a network which specifies a transmitting destination by an address in the network in transmitting data, and also assigns the dial-up connection communication equipment a temporary address in every connection, and the third process includes: a process in which the dial-up connection communication equipment obtains its own address in the current connection; a process in which the dial-up connection communication equipment informs the calling communication equipment of its own address by an electronic mail; and a process in which the calling communication equipment and the dial-up connection communication equipment specify the party at the other end by mutual addresses to communicate with each other.

[Claim 6] The calling method of dial-up connection communication equipment according to claim 1, 2, 3, 4 or 5, wherein after the third process, the calling method further includes a fourth process in which the calling communication equipment directly calls the dial-up connection communication equipment by the communication line to confirm whether or not the dial-up connection communication equipment normally disconnects the line from the communication line.

[Claim 7] A supervisory control system, comprising: a child station having facility equipment; and a parent station for controlling the facility equipment by communication with the child station, wherein the parent station includes: parent station communication means for calling the child station through a ring enable communication line to transmit a connection request, and then communicating with the child station through a network provided separately from the communication line, and the child station includes: child station communication means connected to the network by dialing up it on receiving the connection request through the communication line to communicate with the parent station through the network.

[Detailed Description of the Invention]

[0001]

[Technical Field to which the Invention Belongs]

This invention relates to a calling method of dial-up connection communication equipment connected to a network at need such as communication equipment connected to the

Internet network, for example, by dialing up it and a supervisory control system using it.

[0002]

[Prior Art]

As one of communication means, public telephone line network has been widely used. In this public telephone line network, prior to the communication, the connection (logical channel) is secured between the calling end and the called end to call the called party. In this type of connection mode communication system, the longer the channel is, the more the establishment of connection becomes difficult. Therefore, the public telephone line network generally adopts the rate system according to the communication distance.

[0003]

On the other hand, as new communication means, the Internet network has been spread rapidly in recent years. In the case of the Internet network, the communication equipment at the transmitting end creates datagrams by separating a data raw by each predetermined size upon transmitting data and transmits the same to the adjacent communication equipment. An address (IP address) in the Internet network of the communication equipment at the receiving end is added to each datagram. In the case of receiving the datagram, the communication equipment transmits the data to the communication equipment closer to the receiving end among the adjacent communication equipment according to the IP address of the transmitting destination (the receiving end). Thus, the transmit data can be sent to the receiving end without establishing the connection. In this type of connectionless mode communication system, both of the communication equipment at the transmitting end and at the receiving end do not grasp the channel between them. Therefore, in the case of the Internet network, frequently the rate system according to the quantity of data (the communication time) is adopted, or a fixed rate system is adopted at intervals of a predetermined period such as every year. Since both of rate systems are not susceptible to the distance between the transmitting end and the receiving end, in the long distance communication, especially in the communication with the foreign countries or the like, there is high possibility of reducing the communication cost by communication using the Internet network.

[0004]

Although the Internet network has been used the electronic mail, etc., for data communication mainly composed of characters heretofore, in recent years, with the improvement in bandwidth of the line, it has been used for two-way communication in real time between the communication equipment as well such as a video conferencing system and the Internet telephone.

[0005]

The methods of connecting the respective communication equipment to the Internet network are classified roughly into the connecting using a leased line and the dial-up connection. In the connection method using the leased line, a dedicated communication line is provided between the communication equipment and an Internet connecting firm (a

provider) to thereby always connect each piece of communication equipment and the Internet network. In this case, since the communication equipment is always connected to the Internet network, an inherent IP address is assigned to the communication equipment. This method is adopted in the large companies and universities, and the users always pay fixed expenses as the maintenance costs for the communication line to the telephone company or the like.

[0006]

On the other hand, the dial-up connection is a method of connecting the communication equipment and the Internet network to each other in the case of requiring the connection to the Internet network. The connection to the Internet network is performed by communicating with the provider using the telephone line and relaying this communication by the provider. The provider assigns a free IP address as an IP address of the communication equipment when the communication equipment is put in the connecting state. Thus, the IP address can be shared among a plurality of pieces of communication equipment. Further, this method may dispense with the dedicated communication line between the respective pieces of the communication equipment. As a result, when the amount of communication is small, the connection can be done more inexpensively as compared with the leased line circuit. Accordingly, the dial-up connecting method is adopted mostly in a small firm and a personal house, which have comparatively smaller amount of communication. In this case, the electronic mail is stored by the provider, so the user verifies the arrival of the electronic mail by confirming a predetermined storage area in the provider at every connection.

[0007]

[Problems that the Invention is to Solve]

However, when the called communication equipment adopts the dial-up connection method, the calling communication equipment cannot determine whether or not the called end is connected to the Internet network beforehand. When the communication equipment at the called end is connected to the Internet network at the time of calling, the calling communication equipment can communicate with the called end, but if not so, both of the communication equipment cannot communicate with each other. Consequently, the connection cannot be made surely, resulting in the problem of insufficient quick responsiveness. This problem is critical in the case of speech communication similar to that on the ordinary telephone, in the case of a video conferencing system, and especially in the case of two-way communication in real time.

[0008]

Although this problem occurs when each communication equipment is connected not only to the Internet network but also to the network at need as in the case of personal computer communication, as described in the following, further problems are caused in the case of dial-up connection to the Internet network.

[0009]

To be concrete, the datagram is transmitted according to the respective

communication equipment configuring the Internet network and the IP address of the transmitting destination included in the datagram. Consequently, in communication, the transmitting end has to grasp the IP address of the receiving end. In the dial-up connection method, however, the IP addresses of the respective pieces of communication equipment are not determined until they are connected to the provider. Consequently, the transmitting end cannot grasp the IP address of the receiving end beforehand as in the leased line connection method.

[0010]

In order to solve the above problem, a server having a fixed IP address has been installed heretofore for relaying the communication between the respective pieces of the communication equipment. In this case, the respective pieces of communication equipment start to communicate with the server after connection to the Internet network. When the respective pieces of communication equipment start to communication, the server relays the communication with the equipment at one end to that at the other end. In this case, the datagram transmitted to the IP address of the server is transferred to the communication equipment of the other party, so the respective pieces of communication equipment need not know the IP address of the other party. As a result, the communication can be performed without any obstacle even between the pieces of communication equipment connected to each other by dial-up.

[0011]

In the case of providing the server, however, it is necessary to maintain the server, resulting in newly causing the problem of requiring the maintenance cost. Further encountered is the problem that when the server is busy, even if the relevant communication equipment and the communication equipment of the other party are free, the communication cannot be performed. Further a method of searching for the other party of communication other in the server is not set up, so it is difficult to find a desired other party of communication. For example, at the moment, it is frequent to search for the other party by the following searching method. That is, the respective pieces of communication equipment register its own identifier in the server. The server displays a list of identifiers received, and the respective pieces of communication equipment select a desired other party from the list. According to this method, as the number of connectors increases, the more the time and trouble for searching increases.

[0012]

Further, even if the server is installed, the problem that when the communication equipment of the other party is not connected to the network, communication cannot be started remains unsolved.

[0013]

The invention has been made in the light of the above problems and it is an object of the invention to provide a calling method of communication equipment, which may improve the quick responsiveness of the communication equipment when the called communication

equipment is connected to a network by dial-up.

[0014]

[Means for Solving the Problems]

According to the invention of claim 1, a calling method of dial-up connection communication equipment is a method of calling dial-up connection communication equipment connected to a network by dial-up, and it is characterized in that the method includes the following processes in order to solve the above problems.

[0015]

That is, the method includes: a first process in which calling communication equipment transmits a connection request to dial-up connection communication equipment by a communication line provided separately from the network and capable of calling the dial-up connection communication equipment; a second process in which the dial-up connection communication equipment receiving the connection request is connected to the network by dial-up; and a third process in which the calling communication equipment and the dial-up connection communication equipment communicate with each other through the network.

[0016]

As the above network, cited are connectionless mode network such as the Internet network and personal computer communication, and as the communication line, cited are a telephone line and a harbor radio.

[0017]

Generally the network, which cannot call the other party, is more easily achieved than the communication line, which can call the other party, such as the telephone line. Further, in the case where the communication equipment is connected to the network at need as in the dial-up connection, a channel between the network and the communication equipment and resources on the network such as an address can be shared by the other communication equipment and the other uses. Accordingly, the dialed-up connection communication equipment can be reduced in communication cost as compared with the case of directly communicating using the communication line and the case of connection to the network by a leased line.

[0018]

In the above constitution, before both of the calling communication equipment and the dial-up connection communication equipment communicate through the network, the calling communication equipment transmits a connection request to the dial-up connection communication equipment. Thus, even if the dial-up connection communication equipment is not connected to the network, in communication in the third process, it can be connected to the network. Accordingly, in the dial-up connection communication equipment, which can communicate at a low rate, communication can be surely started in a desired timing to enable real-time communication.

[0019]

According to the invention of claim 2, the calling method of dial-up connection

communication equipment is characterized in that in the constitution of the invention as claimed in claim 1, the third process includes: an encipher process in which the transmitting communication equipment between the calling communication equipment and the dial-up connection communication equipment enciphers and transmits at least part of the data transmitted in the third process; and a decoding process in which the receiving communication equipment decodes the enciphered data.

[0020]

As the method used in encipher, various methods such as a method of using a common key of cryptograph to encipher and decoding and a method of enciphering using a public key and encoding using a privacy key different from the public key may be applied. Both of communication equipment acquire key of cryptograph such as a common key of cryptograph and the public key of the other party by a predetermined method such as communication in the first process or mail prior to the third process.

[0021]

In the case of communication through the network, there is the risk that the transmitted data is wiretapped or altered. Especially in the case of using the Internet network or the like as the network, the communication equipment at the calling end and the communication equipment at the receiving end cannot specify a data transmission channel, so that the degree of risk of communication jamming such as tapping is high.

[0022]

In the above constitution, however, among the communication contents, at least some contents are concealed from a third party other than the calling communication equipment and the dial-up connection communication equipment. As a result, the security to the communication jamming can be improved as compared with the case of transmitting a plaintext as it is without enciphering the communication contents.

[0023]

As the data to be enciphered, cited are the communication contents themselves, and the user names or addresses of both of communication equipment. However, as the amount of data to be enciphered increases, the load of both of the communication equipment increases, so that only part of the data may be enciphered in consideration of the signification of communication. Generally when the user name and address are heard by a third party, the significance of the communication contents is apt to be guessed. Accordingly, in the case of transmitting the user name and address prior to communication such as an image and voice, encryption of these is especially desired. Thus, the security to communication jamming can be improved without much increase in load of both of communication equipment.

[0024]

Further, according to the invention of claim 3, the calling method of dial-up connection communication equipment is characterized in that in the constitution of claim 2, the first process includes: a process in which the calling communication equipment or the dial-up connection communication equipment informs the party at the other end of a key of

cryptograph used in encipher.

[0025]

In the case of using the public key in encipher, the party at the other end is informed of the public key corresponding to its own privacy key. In the case of enciphering using common key of cryptograph, the key of cryptograph is informed to the party at the other end.

[0026]

In the above constitution, the key of cryptograph is informed at every connection request, whereby even when the key of cryptograph is changed from that of the preceding communication, both of communication equipment can transmit and receive the enciphered data smoothly. In addition, both notification of connection request and sending of key of cryptograph are performed in a batch using the communication line. Accordingly, the time and trouble for connecting the communication line can be reduced as compared with the case of individually performing both of the above.

[0027]

Further, in the case of setting the key of cryptograph by mail or the like, the respective pieces of communication equipment have to set the key of cryptograph before use. The key of cryptograph is provided for each of communication equipment, so that especially when the number of parties to communicate increases, the time and trouble for setting increases. On the contrary, in the constitution as described in claim 3 of the invention, the key of cryptograph is informed in every connection, whereby it is not necessary to preset the respective keys of cryptograph, so that the time and trouble for setting can be reduced.

[0028]

The key of cryptograph is transmitted to the communication equipment of the party at the other end through the communication line, and the data enciphered by the key of cryptograph is transmitted through the network. Accordingly, when a third party attempts to interfere the communication, wire tapping of two-way communication is needed. As a result, the security to communication jamming can be improved as compared with the case of transmitting the key of cryptograph and data by single communication means.

[0029]

On the other hand, according to the invention of claim 4, the calling method of dial-up connection communication equipment is characterized in that in the constitution of the invention as claimed in claim 1, 2 or 3, the network is provided with a server for relaying the communication between the calling communication equipment and the dial-up connection communication equipment, and the third process includes: a process in which both of the above communication equipment inform the sever of their own identifications; a process in which both of the above communication equipment inform the server of the identification of the party at the other end to select the communication equipment of the party at the other end; and a process in which the server relays the communication between the selected communication equipment.

[0030]

As the network, cited is a connectionless mode network such as the Internet network. In this constitution, in enciphering in claim 2 or 3, the identifications of both of communication equipment are cited as especially suitable data.

[0031]

In the above constitution, similarly to claim 1, even when the dial-up connection communication equipment is not connected to the network, in communication in the third process, it can be connected to the network. Thus, both of communication equipment can surely start the communication in a desired timing through the server provided in the network. Even when the server makes public the identification, the user identification is enciphered and registered to thereby easily conceal the identifications of both of communication equipment from a third party.

[0032]

According to the invention of claim 5, the calling method of dial-up connection communication equipment is characterized in that in the constitution of the invention as described in claim 1, 2 or 3, the network is a network such as the Internet network, which specifies a transmitting destination by an address in the network in transmitting data, and also assigns the dial-up connection communication equipment a temporary address in every connection, and the third process includes: a process in which the dial-up connection communication equipment obtains its own address in the current connection; a process in which the dial-up connection communication equipment informs the calling communication equipment of its own address by an electronic mail; and a process in which the calling communication equipment and the dial-up connection communication equipment specify the party at the other end by mutual addresses to communicate with each other.

[0033]

In the case of the dial-up connection communication equipment, an address is undetermined until the connection to the network is made. Therefore, according to the conventional method, the calling communication equipment cannot grasp the address of the receiving end so that the dialed connections of communication equipment cannot communicate through the network.

[0034]

On the other hand, as in the constitution of the invention of claim 4, in the case of providing the network with the server for relaying the communication between both of communication equipment, even the dialed-up connections of communication equipment can communicate smoothly. In this case, however, the cost for separately providing the server and the maintenance cost are needed. Further, when the server is busy, there is the risk that both of communication equipment cannot communicate.

[0035]

On the contrary, in the constitution of the invention as described in claim 5, at the point of time the dial-up connection communication equipment determines its own address after connection to the network, it can inform the calling communication equipment of the

address. Thus, both of communication equipment can communicate through the network without providing the server as in the constitution of claim 4. Accordingly, the cost required for communication can be further reduced as compared with the constitution of the invention described in claim 4, and also both of communication equipment can surely communicate regardless of congestion in the server.

[0036]

At the end of communication through the network, the dial-up connection communication equipment disconnects the connection to the network. In this case, when the dial-up connection communication equipment fails in disconnection of the line from the network, the dial-up connection communication equipment continues the connection to the network, so that the communication cost is raised against our desire. Especially, when no user is present in the periphery of the dial-up connection communication equipment such as the case where the dial-up connection communication equipment is a child station of a monitoring control system, failure in line disconnection is hard to grasp. Accordingly, when failure in line disconnection occurs, the period of time the dial-up connection communication equipment is connected to the network against our desire is apt to get longer, resulting in the high risk of increasing wasteful communication cost.

[0037]

On the contrary, according to the invention of claim 6, the calling method of dial-up connection communication equipment is characterized in that in the constitution of the invention described in claim 1, 2, 3, 4 or 5, after the third process, the calling method further includes a fourth process in which the calling communication equipment directly calls the dial-up connection communication equipment by the communication line to confirm whether or not the dial-up connection communication equipment normally disconnects the line connection to the communication line.

[0038]

In the above constitution, at the end of communicating with the dial-up connection communication equipment, the calling communication equipment confirms whether the line disconnection is successful or not by ring tone in direct calling. Thus, the calling communication equipment can surely recognize the line disconnection failure of the dial-up connection communication equipment. Accordingly, it is possible to take suitable measure such as the calling communication equipment's again designating the dial-up connection communication equipment to disconnect the line or the calling communication equipment's user leaving for the installation place of the dial-up connection communication equipment to disconnect the line. As a result, the occurrence of wasteful communication cost due to failure in line disconnection can be surely prevented.

[0039]

In the case of the communication line using ring tone different between the period the line is connected and the period the line is disconnected, the dial-up connection communication equipment is set so that call-in is not caused until a predetermined number of

times of ring tone, and in conformation, the calling communication equipment discriminates the ring tone before it reaches the predetermined number of times, thereby confirming the disconnection of the line. In this case, when the calling communication equipment disconnects the line used for direct call before it reaches the predetermined number of times, the communication cost is not needed even when the dial-up connection communication equipment can normally disconnect the line from the network.

[0040]

When the calling method of dial-up connection communication equipment related to the invention of claim 1 is used, it is possible to construct a communication system, which may start the communication in a desired timing, and reduce the communication cost.

[0041]

In this case, in the supervisory control system, generally, a child station is installed in a place away from a parent station, and the parent station monitors and controls a number of child stations. Therefore, the cost for communication between the parent station and the child stations is liable to increase, and there is a strong demand toward reduction of communication cost. Especially, in the case where the data transmitted to the parent station by the child station is video data such as the case of monitoring the installation place, the amount of data is very large so that when the data is transmitted through a ring enable communication line, high communication cost is needed. On the other hand, in the supervisory control system, delay of designation is directly linked with escalation of an accident so that the child station has to instantaneously respond to designation of the parent station. Therefore, when the child station communicates with the parent station through the network only connected by dial-up connection, the child station cannot respond to the designation of the parent station and there is the risk of escalating the accident. As a result of these, in the monitor and control system, while the quick responsiveness of the child station to the designation of the parent station is kept, reduction of communication cost is strongly demanded.

[0042]

On the contrary, according to the invention of claim 7, in order to solve the above problem, a supervisory control system includes: a child station having facility equipment; and a parent station for controlling the facility equipment by communication with the child station, and the monitor and control system is characterized in that the parent station includes: parent station communication means for calling the child station through a ring enable communication line to transmit a connection request, and then communicating with the child station through a network provided separately from the communication line, and the child station includes: child station communication means connected to the network by dialing up it on receiving the connection request through the communication line to communicate with the parent station through the network.

[0043]

In the above constitution, the parent station communication means of the parent

station calls the child station through a communication line such as a telephone at an arbitrary point of time such as a point of time user's designation is given. On the other hand, the child station communication means of the child station receives a connection request from the parent station and then sets up the connection to the network such as the Internet by dial-up connection. After that, the parent station and the child station transmit and receive the data through the network.

[0044]

In the above constitution, the child station is connected to the network by dial-up connection, which enables communication at a low rate, whereby the communication cost can be remarkably reduced as compared with the case where the child station and the parent station communicate using the communication line only. On the other hand, after the parent station calls the child station using the ring enable communication line, the data is transmitted and received through the network, so that the parent station can start communication with the child station in a desired timing. As a result of these, it is possible to achieve the supervisory control system, which may remarkably reduce the communication cost between the child station and the parent station while the child station can instantaneously respond to the designation of the parent station.

[0045]

[Mode for Carrying Out the Invention]

[First Embodiment] One embodiment of the invention will now be described according to Figs. 1 to 4. A calling method of dial-up connection communication equipment according to the present embodiment is a calling method applied to a communication system in which the calling end and the called end communicate through a telephone line and the Internet network and also at least the called communication equipment is connected to the Internet network by dial-up, and this is a preferable method especially for long-distance communication such as between Japan and the U.S.A. The dial-up connection is a method of connecting the communication equipment, which is not always connected to the network such as the Internet network, to the network when each of communication equipment determines to need connection.

[0046]

In the following, prior to the description of the above calling method and communication equipment for implementing the method, a communication system using the communication equipment will be described. That is, as shown in Fig. 1, a communication system 1 according to the present embodiment includes the above calling method, and the system is provided with communication equipment 2 and 3 which are at the calling end or at the called end, respectively. In the present embodiment, which communication equipment 2, 3 is at the calling end or at the called end is not especially determined, and both of communication equipment 2 and 3 have the functions of both the calling end and the called end as mentioned later. The communication equipment 2, 3 at the called end corresponds to the dial-up connection communication equipment described in the scope of the claims.

[0047]

Both of the communication equipment 2, 3 are respectively connected to a telephone line (a communication line) 4. The telephone line 4 is a digital line such as ISDN (Integrated Services Digital Network) or an analog line, and the respective communication equipment 2, 3 can inform a switchboard not shown of the telephone line 4 of the telephone number of the party at the other end by dialing. Thus, the respective communication equipment 2 and 3 can mutually call the party at the other end through the telephone line 4 to directly communicate with each other.

[0048]

The users of the respective communication equipment 2 and 3 join the Internet connection firms (provider) 5 or 6, and the communication equipment 2, 3 can respectively use the Internet network (network) 7 by dial-up connection. Since the communication equipment 2, 3 are respectively at the calling end in some case and at the called end in some case, both of providers 5, 6 are required to have the same function. In the following, although the provider 5 on the communication equipment 2 side will be described for the sake of convenience, the configuration of the provider 6 is the same.

[0049]

To be concrete, on receiving a connection request from the communication equipment 2 through the telephone line 4, the provider 5 causes the communication equipment to input ID showing an account (use capability) and a password preset by each ID. At the end of checking the account with the password, the provider 5 assigns a free IP address among its possessed addresses (IP addresses) on the Internet network 7 as a temporary IP address of the communication equipment 2. Thus, the communication equipment 2 can recognize its own IP address in current connection. As a result, the communication equipment 2 can create a data row (datagram) divided by each predetermined size, transmit the same to the provider 5, and discriminate the datagram addressed thereto out of the datagram received from the provider 5. The provider 5 transfers the datagram from the communication equipment 2 to the Internet network 7, and transmits the datagram from the Internet network 7 to the communication equipment 2. Thus, the communication equipment 2 can be connected to the Internet network 7 without any inherent IP address.

[0050]

The provider 5 shares the IP address and the connection line with the Internet network 7 among subscribers of dial-up connection. Accordingly, in the provider 5, the connection rate of the dial-up connection is often set to a lower rate as compared with the case where the communication equipment 2 holds an inherent IP address, and is always connected to the Internet network 7 through a leased communication line, that is, the case of leased line connection.

[0051]

The provider 5 is provided with an access point for communicating with the communication equipment 2 through the telephone line 4. The access point is disposed near

to the communication equipment 2 such as the range of speech communication specified by local exchange code, and the communication equipment 2 can hold down the rate (telephone charge) of the telephone line 4 in communicating with the provider 5.

[0052]

Further, the provider 5 is a main server of the communication equipment 2 as well. To be concrete, the provider 5 previously assigns an electronic mail address to the communication equipment 2 and includes a storage area (a mail box) not shown corresponding thereto. The electronic mail addressed to the communication equipment 2 is delivered to the provider 5, and the provider 5 receives the electronic mail addressed to the communication equipment 2 and stores it in the corresponding mailbox. The provider 5 is always connected to the Internet network 7, and the IP address is always constant. Accordingly, the electronic mail is surely delivered whether the communication equipment 2 is connected to the Internet network 7 or not and regardless of the IP address in connection. Each of communication equipment 2 can read out an electronic mail addressed to itself from the mailbox in connection by dial-up.

[0053]

At present the Internet network has been spread widely and a number of providers have started to provide service. Most of these providers support dial-up connection and have a function of a mail server. Accordingly, the communication system 1 of the present embodiment can be easily configured by providing the communication equipment 2 and 3.

[0054]

The following description mainly deals with the case of transmitting both a voice and an image as in a video conference as configuration examples of the communication equipment 2 and 3. In the following, not only the case of transmitting both of a voice and an image but also the real-time transmission of data through the network such as the Internet network 7 by both communication equipment 2 and 3 are known generally as network conference.

[0055]

As to a method of achieving the respective pieces of communication equipment 2 and 3, although various configurations are considered as mentioned later, the description will now deal with the configuration in which the communication equipment 2(3) includes: a connector 2a (3a) controlling the connection between the telephone line 4 and the Internet network 7; and a computer 2b (3b) serving as an input/output device. In this configuration, the calling method of the present embodiment is implemented by the connector 2a. The communication equipment 2 and 3 are respectively provided with telephone sets 2c, 3c for ordinary speech communication except communication according to the above calling method. Since both of communication equipment 2 and 3 have the same configuration, in the following, for the sake of convenience, only the configuration of the communication equipment 2 will be described in detail.

[0056]

That is, the computer 2b includes an input device not shown such as a video camera

and a microphone, wherein the voice and image of the user side can be transmitted as a digital data row to the connector 2a. Further, the computer 2b includes an output device (not shown) such as a monitor and a speaker, wherein the data row received from the communication equipment 3 through the connector 2a can be informed as an image and a voice to the user.

[0057]

The computer 2b and the connector 2a are connected to each other by a previously selected communication method such as RS232C, RS422A, IrDA or LAN, whereby data can be transmitted and received in two-way. As to the communication method between both, it doesn't matter whether wired or wireless, or digital or analog, and also what the communication speed and the communication standard are like if only two-way communication is enabled in real time.

[0058]

On the other hand, the connector 2a of the present embodiment, as shown in Fig. 2, includes: a flash memory 11 for storing a program for implementing the calling method of the present embodiment and various settings; an interface part 12 communicating with the computer 2b in the above predetermined communication method; a communicating IC (Integrated Circuit) 13 connected to the telephone line 4 and the telephone set 2c; a CPU (Central Processing Unit) 14 for controlling the whole connector 2a; and a RAM (Random Access Memory) 15 serving as a working storage. Further, a status display liquid crystal panel 16 is provided to display the status of the connector 2a such as the electronic mail address of the communication equipment 3. The respective members 11 to 16 are respectively connected to a bus 17, and the data is transmitted between the respective members through the bus 17.

[0059]

The above flash memory 11 is an electrically reloadable non-volatile memory, which stores a program for performing the operation mentioned later and various set points used in the concerned program. To be concrete, as the set points concerning the communication equipment 3, cited is a telephone number in a direct call. Further, the memory stores a password for identifying the communication equipment 2 by the communication equipment 3 in a direct call. The concerned password is previously transmitted to the communication equipment 3, and the communication equipment 3 can determine whether or not the password is a call from a regular user by checking. Further, as the set points concerning the provider 5, a telephone number of the provider 5, an account, a password and its own electronic main address are stored. Further, in the present embodiment, in communication through the Internet network 7, the communication equipment 2 and the communication equipment 3 communicate by enciphering at least part of the communication contents using the public key cryptosystem such as RSA code. Accordingly, the flash memory 11 stores a privacy key used in encipher and decoding and a public key as well. Naturally instead of the flash memory 11, non-volatile record means such as ROM (Read-Only Memory), a battery back-up

RAM or a hard disk may be used.

[0060]

The interface part 12 is an interface such as RS232 C interface according to a method of communication between the computer 2b and the connector 2a, and the CPU 14 can communicate with the computer 2b through the interface part 12.

[0061]

Further, the communicating IC 13 is an IC for MODEM, which may control the line connection/disconnection of the telephone line 4, and convert a data row processed by the CPU 14 from and to an electric signal transmitted through the telephone line 4. Further, according to the designation of the CPU 14, the telephone line 4 and the telephone set 2c can be connected to each other to ring the bell of the telephone set 2c.

[0062]

On the other hand, the CPU 14 controls the interface part 12 and the communicating IC 13 according to the program of the flash memory 11. To be concrete, the connector 2a can be directly communicated with the communication equipment 3 through the telephone line 4 by dialing a desired telephone number or connected to the Internet network 7 through the provider 5. Thus, the connector 2a can perform direct communication through the telephone line 4 and communication through the Internet network 7 in a predetermined order as mentioned later.

[0063]

The CPU 14 can control the computer 2b and the telephone set 2c through the interface part 12 or the communicating IC 13. Thus, the connector 2a can determine whether or not the computer 2b designates the connection through the Internet network 7 from the user by keying or the like, and a connecting destination. The connector 2a connects the telephone line 4 and the telephone set 2c to each other to perform ordinary speech communication.

[0064]

In the case of direct connection through the telephone line 4, the CPU 14 can transmit a predetermined message to the communication equipment 3 through the communicating IC 13, and also identify the message received from the communication equipment 3. The communication method between the communication equipment 2 and 3 is serial communication according to the standards V32, V32bis, V34, V21 or V22, in which a message can be transmitted and received between them.

[0065]

On the other hand, in the case where the communication equipment 2 and the provider 5 are connected to each other by dial-up, the CPU 14 transmits and receives datagram to and from the provider 5 through the communicating IC 13. Thus, the connector 2a can recognize the IP address in current connection and also transmits an electronic mail in a predetermined format. Further, the connector 2a confirms its own mailbox provided in the provider 5 in a predetermined period to determine whether or not the electronic mail from the communication equipment 3 arrives. When the electronic mail has arrived, the contents of

the electronic mail are confirmed to recognize the IP address of the other party.

[0066]

In addition, in the case of connection through the Internet network 7, the CPU 14 controls the interface part 12 and the communicating IC 13 to relay the communication between the computer 2b and the Internet network 7. In the case where data is transmitted in a format different from that of datagram transmitted through the Internet network 7 such as a voice data row and an image data row between the computer 2b and the connector 2a, the CPU 14 converts both of them mutually. On the other hand, in the case of transmitting the datagram to the computer 2b, the CPU 14 passes the datagram as it is. Thus, the connector can smoothly relay the communication between the computer 2b and the Internet network 7.

[0067]

Further, the CPU 14 can encipher the data transmitted to the communication equipment 3 using the public key of the communication equipment 3 or decode the data received from the communication equipment 3 using its previously stored own privacy key.

[0068]

Although the computer 2b is in charge of input/output in the communication equipment 2 in the above description, the input/output device is not limited to this. As described above, as to the communication method between the input/output device such as the computer 2b and the connector 2a, it doesn't matter whether wired or wireless, or digital or analog, and also what the communication speed and the communication standard are like. Accordingly, various input devices such as a telephone set and a video camera can be used. In this case, however, the connector 2a need to convert the datagram transmitted by the Internet network 7 and the data between the telephone set 2c and the connector 2a mutually.

[0069]

Especially as shown in Fig. 3, in the case of using a telephone set 22c as an input device of communicating equipment 22, the telephone set 22c can be used both in speech communication through the Internet network 7 and ordinary speech communication. Further, it will be sufficient to provide a connector 22a between the telephone set 22c having the same configuration as the conventional one and the telephone line 4, the installation can be more facilitated as compared with the case of providing another input device.

[0070]

In this case, since the input device is only the telephone set 22c, it is necessary to discriminate between speed communication through the Internet network 7 and ordinary speed communication. Although a switch or the like is provided on the connector 22a, thereby designating the speech communication through the Internet network 7, the following method may be adopted to allow the user to discriminate between them using the telephone set 22c only. That is, the user presses a button for a preset register number of the party at the other end after the operation not used in the ordinary speech communication such as pressing the “#” button three times on lifting a telephone receiver. The connector 22a recognizes the above button operation according to a voice signal sent from the telephone set 22c to identify

the occurrence of a connection request and the party at the other end. When speech communication with the other party is enabled through the Internet network 7, the user is notified by ringing a bell of the telephone set 22c or the like. On the other hand, when an ordinary telephone number is pressed, the connector 22a determines the ordinary speech communication according to a signal from the telephone set 22c, and passes the signal intact to the telephone line 4. Thus, the telephone set 22c can perform a direct call through the telephone line 4 similarly to the case without the connector 22a. Thus, as the operation for designating the communication through the Internet network 7, the operation not used ordinarily is assigned by the input device, whereby a connection request through the Internet network 7 and an ordinary communication connection request can be discriminated only by using the same input device as the conventional one.

[0071]

Although the above description deals with the case in which the computer 2b is in charge of input/output, and the connector 2a is in charge of controlling the connection order to the telephone line 4 or the Internet network 7 or encryption in the communication equipment 2, the role sharing between both members 2a, 2b is also not limited to this. For example, the processing of the connector 2a such as the above connection order control and the encryption may be mostly performed by the computer 2b. In this case, ordinary MODEM or a terminal adaptor of ISDN may be applied to the connector 2a.

[0072]

In Fig. 1 and Fig. 3, although the connector 2a (22a), the computer 2b and the telephone set 2c (22c) are respectively described as separate members for the sake of convenience of description, naturally they may be integrated. As an example of integration, cited are a domestic television set shown in Fig. 1, in which the connector 2a and the computer 2b are integrated and a telephone set shown in Fig. 3, in which the connector 22a and the telephone set 22c are integrated. Further, when a wireless telephone line is used as the telephone set 4, the above integrated telephone set may be constructed as a cellular phone. When a video camera is adopted as the input/output device and integrated with the connector 2a, it is possible to achieve the video camera, which may transmit an image and a video through the Internet network 7. In this case, more preferably a wireless telephone line is used so that the video camera is made portable. The selective combination of integration/separation or input/output device, and further wireless or wired telephone line 4 will achieve various configurations of communication equipment 2.

[0073]

The operation in the case where the communication equipment 2 calls the communication equipment 3 in the communication system 1 shown in Fig. 1 will now be described step by step according to the flowchart shown in Fig. 4.

[0074]

That is, when the user of the communication equipment 2 designates the communication equipment 2 to communicate with the communication equipment 3 by keying

of the computer 2b, in the step S1a, the communication equipment 2 dials the telephone number of the communication equipment 3. Thus, the communication equipment 3 is called through the telephone line 4. In the following, the step S1a is abbreviated as S1a simply. Further, the processing conducted by the communication equipment 2 is indicated by adding a final letter (a) such as S1a, and the processing conducted by the communication equipment 3 is indicated by adding a final letter (b) such as S1b to discriminate between them.

[0075]

On the other hand, in the case of ready for communication, the user of the communication equipment 3 designates the communication equipment 3 to turn on "receive wait" by previously pressing a button or the like (S1b). When the "receive wait" is on state, the communication equipment 3 responds to a telephone call (S2b). As a result, the communication equipment 2 and the communication equipment 3 can start direct communication through the telephone line 4.

[0076]

On detecting the response of the communication equipment 3, the communication equipment 2 transmits a predetermined message such as "CALL CU-SEEME from user name of the communication equipment 2, PASSWORD: user's electronic mail address of the password communication equipment 2, public key of the communication equipment 2" to inform the communication equipment 3 of user name of the communication equipment 2, password, electronic mail address, and public key of the communication equipment 2 used in communication (S2a). The communication equipment 3 checks the combination of received user name and password with the previously stored combination to determine whether or not the party is a qualified communication party (S3b). When the party is not the qualified communication party, for example, when the user name or password is wrong, or the party at the other end speaks by a voice, the connector 3a of the communication equipment 3 rings the bell of the telephone set 3c to connect the telephone line 4 and the telephone set 3c (S4b). Thus, the user of the communication equipment 3 can talk with the party at the other end using the telephone set 3c. In this case, the following processing is not conducted.

[0077]

On the other hand, in the above S3b, when the qualified communication party is verified, the communication equipment 3 transmits a predetermined message such as "OK CU-SEEME from the user name of the communication equipment 3, user's electronic mail address of the communication equipment 3 and public key of the communication equipment 3" (S5b), and the communication equipment 2 receives the message (S3a). Thus, the communication equipment 2 can obtain the receipt of its own connection request by the communication equipment 3, the user name of the communication equipment 3, electronic mail address and the public key of the communication equipment 3 used in communication.

[0078]

After that, the communication equipment 2 and 3 disconnect their connection to the telephone line 4 (S4a, S6b), and start dialing-up a predetermined provider 5 or 6 (S5a, S7b).

In the respective communication equipment 2 and 3, the connectors 2a, 3a designate the computer 2b to start network conferencing software previously provided on the computer 2b such as CU-SEEME developed by Corel University (S6a, S8b).

[0079]

In the above S5a and S7b, when dial-up connection is successful, the communication equipment 2 and 3 obtain IP address for the current connection only from the respective providers 5, 6 (S7a, S9b). As a result, the respective communication equipment 2 and 3 can transmit the datagram to the Internet network 7.

[0080]

At this point of time, however, the communication equipment 2 and the communication equipment 3 do not grasp the IP address of the party at the other end so that the datagram addressed to the party at the other end cannot be generated. Therefore, although the communication equipment 2 and 3 can communicate with the equipment having the predetermined IP address such as the providers 5, 6, the communication between both of the communication equipment 2 and 3 cannot be started.

[0081]

Subsequently, the respective communication equipment 2 and 3 encipher their own names and own IP addresses using the public key sent from the party at the other end in the above S2a or S5b. After that, the communication equipment 2 and 3 transmit the cryptogram as an electronic mail to the electronic mail address of the party at the other end (S8a, S10b). Each electronic mail is enciphered by the public key of the party at the other end, so that it cannot be decoded without the privacy key held by the party at the other end.

[0082]

The communication equipment 2 and 3 monitor their own mailboxes provided on the providers 5, 6 at a predetermined period such as the intervals of five seconds. When the electronic mail arrives from the party at the other end, the communication equipment 2 and 3 read the electronic mail from the mailbox and perform decoding using their own privacy keys. Thus, the communication equipment 2 and 3 can obtain the name and IP address of the party at the other end (S9a, S11b).

[0083]

Further, on receiving the IP address of the party at the other end, the communication equipment 2 and 3 inform the network conferencing software of the IP address to call the party at the other end. Thus, at the network conferencing software, the communication is started (S10a, S12b).

[0084]

Each datagram includes the IP address of the transmitting end in addition to the IP address of the transmitting destination. Thus, when one communication equipment 2 (3) calls the communication equipment 3(2) of the party at the other end, the called network conferencing software can recognize the calling IP address based upon the received datagram. Accordingly, the communication can be started at the point of time one calls. To be concrete,

when the processing of the above S10a starts earlier than the processing of the S12b, the communication equipment 3 need not to conduct the above processing S11b. Similarly when the above S12b starts earlier, the communication equipment 2 may omit the processing of the S9a. The network conferencing software is created to communicate even when they mutually call at the same time, so that even when each processing S9a, S11b is not omitted, the communication can be started smoothly.

[0085]

Further, at the point of time one communication equipment 2(3) calls the communication equipment 3(2) of the party at the other end, the communication can be started, so that during dial-up connection of both communication equipment 2 and 3, even if one of them does not transmit an electronic mail, both communication equipment 2 and 3 can start communication. However, when both communication equipment 2 and 3 transmit electronic mails, the communication can be started the moment the electronic mail of one of them arrives, so that the probability of more early starting the communication can be made higher as compared with the case where only one transmits an electronic mail.

[0086]

During the conference, the voice and image from the computer 2b are transmitted to the computer 3b through the connector 2a, the provider 5, the Internet network 7, the provider 6 and the connector 3a, and the voice and image from the computer 3b are transmitted in the opposite direction through the above path. Thus, the users of the communication equipment 2 and the communication equipment 3 can communicate by the network conference software (S10a, S12b). At the end of conference, the communication equipment 2 and 3 respectively disconnect dialed connection (S11a, S13b) to end the communication between the communication equipment 2 and 3.

[0087]

When the user at the receiving end is absent, for example, or when communication through the Internet network 7 is not desired, the connector 3a is designated to turn off "communication wait" by pressing a predetermined button or the like. In this case, the connector 3a makes the connection to the telephone set 3c unconditionally without conducting the processing of the S2 and subsequent steps.

[0088]

In the case of communication through the Internet network 7, it is unknown at the time of sending what the path of datagram transmitted by the communication equipment 2 and 3 is like to reach an address like, and the equipment constituting the Internet network 7 determines the next equipment to pass the datagram on receiving the datagram.

[0089]

Consequently, in the equipment where each datagram passes, the datagram is easily altered and copied, so that communication jamming is easily caused as compared with the case of direct communication through the telephone line 4. Especially in the case of transmitting the user name and IP address still in a plaintext by an electronic mail, the

significance of communication can be judged from the user name so that the possibility that the subsequent communication is subjected to jamming as a priority becomes higher. On the other hand, arithmetic processing is essential to encryption and decoding, so that a higher throughput is demanded from the communication equipment 2 and 3 as compared with the case where encryption is not performed.

[0090]

Accordingly, in the present embodiment, in order to achieve compatibility between load in communication and security to jamming, only the contents of the electronic mail are enciphered. However, when further higher security to jamming is required, the communication contents are enciphered also during the communication period of the network communication software to thereby improve the security comparatively easily.

[0091]

Further, since the path for passing each datagram is not determined, it is difficult to assure the arrival time of the datagram. In a certain channel, when the amount of data exceeds the tolerance, there is the risk of losing datagram. In the communication system 1 of the present embodiment, however, in order to transmit the voice data and the image data, the communication equipment 2 and 3 are connected to the Internet network 7 through the communication line having enough communication capacity. When both providers 5, 6 are selected, a provider which connects both providers 5, 6 by a line having enough communication capacity is selected. Therefore, when the data amount is much smaller like an electronic mail as compared with the voice data and the image data, there is practically very low degree of risk of delay and loss. If an electronic mail does not arrive within a predetermined time, when the electronic mail is retransmitted, the possibility of delay and loss can be further reduced.

[0092]

Although both communication equipment 2 and 3 exchange electronic mail addresses between them through the telephone line 4 prior to the communication through the Internet network 7 in the present embodiment, this is not restrictive. For example, an electronic mail address of the party at the other end may be previously stored in the flash memory 11 shown in Fig. 2 or the like. The electronic mail address is, however, changed on the convenience of the user in some case. In that case, it takes the time and trouble for the user of the communication equipment 2, 3 to inform the party at the other end of a new electronic mail address every time they change the electronic mail address, and for the user of communication equipment 2, 3 at the other end to reset the received electronic mail address on the communication equipment 2, 3. On the contrary, in the present embodiment, the electronic mail addresses are mutually informed at every calling, whereby the time and trouble for changing the electronic mail address can be remarkably reduced.

[0093]

[Second Embodiment]

According to the first embodiment, as separate communication means from the

telephone line 4, the Internet network 7 is used, and the communication equipment 2 and the communication equipment 3 directly communicate through the Internet network 7. On the contrary, as shown in Fig. 5, a communication system 31 of the present embodiment is the same as the first embodiment in that as a separate communication line from a telephone line 34, the Internet network 37 is used. However, the difference is that communication equipment 32 and communication equipment 33 communicate through a server 38 provided on the Internet network 37. In the communication system 31, the respective members of from the communication equipment 32 to the Internet network 37 have the substantially similar functions to those of the communication equipment 2 to the Internet network 7. Therefore, only the different parts will be described, and the description of the similar parts will be omitted.

[0094]

A server 38 provided in the communication system 31 of the present embodiment is called reflector, which has an inherent IP address and may relay the communication between the communication equipment 32 and 33 communicating with the server 38. To be concrete, the server 38 is provided with an area for storing combination of an IP address and identification of the current communicating equipment. When each of equipment informs the server 38 of the identification, the server 38 stores the combination of the IP address and identification of the equipment in the above area. Further, the server 38 may transmit a list of identifications from the above area according to equipment's request. Thus, each of equipment can know the identification of the current communication enabled equipment through the server 38. Further, the equipment specifies the identification to the server 38 to select a desired party at the other end of communication.

[0095]

The server 38 stores the IP addresses and identifications of all of equipment on storing the identification of the equipment. Therefore, the server 38 may transmit datagram received from one end to the IP address of the other end when the equipment specifies the party at the end of communication. The server 38 may transfer the datagram received from some equipment to two or more pieces of equipment. In this case, two or more pieces of equipment can communicate with each other.

[0096]

At present, various servers 38 are provided on the Internet network 37, and among them, some server 38 makes public its IP address to be used by unspecified individuals. Thus, these servers 38 are selected to easily constitute the above communication system 31.

[0097]

In the present embodiment, the hardware configurations of the communication equipment 32 and 33 are the same as those of the communication equipment 2 and 3 as shown in Fig. 1, and the operation varies with a difference in loaded software. Accordingly, in the following, the operation when the communication equipment 32 calls the communication equipment 33 will be described, and the description of the hardware configuration is omitted.

[0098]

As shown in the flowchart of Fig. 6, the calling method of the present embodiment includes steps (S21a to S31a and S21b to S33b) of conducting the same processing as those of step S1a to S11a and S1b to S13b shown in Fig. 4.

[0099]

However, although in specifying the party of communication at the other end, the communication equipment 32 and 33 mutually exchange IP addresses using electronic mails in the first embodiment, according to the present embodiment, the communication equipment 32 and 33 register predetermined identifications in the server 38 and select the identification of the party at the other end to specify the party of communication at the other end. Therefore, instead of the steps of exchanging their own IP addresses as in the steps S8a, S9a and S10b, S11b shown in Fig. 4, the following steps S28a, S29a and S30b, S31b are provided. In the S22a and S25b, the communication equipment 32 and 33 omit notification of an electronic mail address.

[0100]

That is, at the end of processing in the S27a and S29b, the communication equipment 32, 33 may transmit datagram including its own IP address to the Internet network 37 through the providers 35, 36. At this point of time, in the S22a or S25b, the public key and user name transmitted by the party at the other end are obtained.

[0101]

The communication equipment 32 and 33 encipher their user names by the public key. Further, the communication equipment 32, 33 inform the server 38 of the enciphered user names as identifications. The server 38 registers the combination of the identifications and IP addresses of the communication equipment 32, 33 (S28a, S30b). The server 38 can obtain the respective IP addresses according to the datagram transmitted when the communication equipment 32, 33 inform the identifications.

[0102]

In the present embodiment, the identifications of the communication equipment 32, 33 are enciphered and registered in the server 38. Accordingly, although a third party communicating with the server 38 can look at a list of identifications, the user names are unknown. As a result, similarly to the case of enciphering the electronic mail in the first embodiment, also in the present embodiment, the user name can be concealed from a third party.

[0103]

Subsequently, the communication equipment 32 and 33 cause a request for a list of identifications to the server 38. Further, the communication equipment 32 and 33 decode the respective identifications in the list using its own privacy key to select the identification in which a match between a previously informed user name and the decoding result occurs. After that, the communication equipment 32 and 33 inform the server 38 of the identification as the party of communication at the other end (S29a, S31b). The server 38 obtains one IP

address from datagram used in notification, and obtains the other IP address from the IP address corresponding to the identification. After that, on receiving datagram from one of both IP addresses, the server 38 transfers the datagram to the other IP address. Thus, the communication equipment 32 and 33 may perform two-way communication even if they do not know the IP addresses mutually. In the present embodiment, similarly to the above first embodiment, during communication using the network conferencing software, the communication equipment 32 and 33 do not encipher the contents of communication to reduce the load in communication. However, the contents of communication are enciphered by the public key of the party at the other end also during the period to further improve the security to communication jamming.

[0104]

After the S29a, S31b, substantially similarly to the first embodiment, the communication equipment 32 and 33 perform two-way communication using the network conferencing software and then disconnect dialed connection at the end of a conference, thereby ending the communication.

[0105]

In the communication system 31 of the present embodiment, the server 38 relays the communication so that when the communication equipment 32 calls the communication equipment 33, mutually they do not require the IP address. It will be sufficient that both providers 35, 36 are not electronic mail servers of the communication equipment 32 and 33, and the communication equipment 32 and 33 cannot transmit and receive an electronic mail. Also in this case, the same effect as that of the present embodiment can be obtained.

[0106]

The communication equipment 32, 33 need to inform the identification to the IP address of the server 38 in the above S28a, S30b. This IP address may be previously stored in the flash memory 11 shown in Fig. 2, or make arrangements for it in the process of communication on the telephone line 34. Before registration in the above S28a, S30b, if a common server 38 is specified between the communication equipment 32 and 33, it does not matter how the server 38 is specified.

[0107]

[Third Embodiment]

According to the first and second embodiments, as communication means separate from direct communication using the telephone lines 4, 34, the Internet networks 7 and 37 are used. On the contrary, in the present embodiment, as separate communication means, the case of using personal computer communications will be described.

[0108]

As shown in Fig. 7, in a communication system 41 of the present embodiment, the users of communication equipment 42 and 43 enter the personal computer communications, and the communication equipments 42 and 43 telephone neighboring access points 45, 46 to be connected to a personal computer communication server 47 by dial-up.

[0109]

The personal computer communication server 47 communicates with the communication equipment 42 and 43 to provide predetermined services such as database retrieval. Further the personal computer communication server 47 of the present embodiment may relay the communication between both communication equipment 42 and 43 similarly to the server 38 shown in Fig. 5. Thus, two-way communication can be performed between both communication equipment 42 and 43 through the personal computer communication server 47.

[0110]

The personal computer communication server 47 administers the subscribers by ID or the like, and checks ID and password when the communication equipment 42 and 43 are connected through a telephone line 44 to identify the communication equipment 42 and 43, respectively, similarly to the provides 5 and 6 as shown in Fig. 11. However, differently from the case of communication through the Internet network 7 as in the communication system 1 shown in Fig. 1, in the communication system 41 shown in Fig. 7, the IDs of both communication equipments 42 and 43 are managed by the personal computer communication server 47. Accordingly, in the communication system 41, the communication party at the other end is specified by the respective IDs. The respective access points 45, 46 and the personal computer communication server 47 are connected to each other by leased lines 48, 48.

[0111]

Currently many the personal computer communication servers 47 are provided. Therefore, one of them is selected and the communication equipment 42, 43 are provided to comparatively easily constitute the communication system 41.

[0112]

The communication equipment 42 and 43 of the present embodiment are the substantially same hardware components as the communication equipment 2, 3 (22) shown in the first embodiment. However, the communication equipment 42 and 43 of the present embodiment transmit and receive data of a format corresponding to the communication mode with the personal computer communication server 47 when they are connected to the personal computer communication server 47. The transmission and receiving of the data of the format may be easily achieved by partially altering the hardware or software of the communication equipment 2 and 3.

[0113]

In the above configuration, when the communication equipment 42 calls the communication equipment 43, the communication system 41 is operated as shown in Fig. 8. That is, in the steps from S41a to S44a and from S41b to S46b, the communication equipment 42 conducts the same processing as that of Fig. 6 before communication through the personal computer communication server 47, thereby calling the communication equipment 43 through the telephone line 44 to transmit a connection request. At this time, both communication

equipment 42 and 43 exchange public keys with each other.

[0114]

Subsequently, in the steps from S45a to S48a and from S47b to S50b, similarly to Fig. 6, both communication equipment 42 and 43 are respectively connected to the personal computer communication server 47 by dial-up to communicate through network conferencing software.

[0115]

In the present embodiment, however, the communication party at the other end is specified by using ID inherent to the communication equipment 42 and 43. Accordingly, the processing in the steps from S27a to S29a and from S29b to S31b is omitted. According to the present embodiment, in the S47a and S49b, in communication using the network conferencing software, both communication equipment 42 and 43 encipher and transmit the contents of communication using the public key of the party at the other end, which is exchanged with each other through the telephone line 44. The enciphered communication contents are decoded by its own previously held privacy key. Thus, the communication contents can be concealed from a third party.

[0116]

[Fourth embodiment]

The description of the above first to third embodiments deals with the configuration using the calling method of the dial-up connection communication equipment according to the invention even when communication equipment 2 (32, 42) calls the communication equipment 3 (33, 43), and on the contrary, even when the communication equipment 3 (33, 43) calls the communication equipment 2 (32, 42). However, the calling method of the dial-up connection communication equipment may be used only when the communication equipment at one end calls the other communication equipment.

[0117]

The case of using the calling method of dial-up connection communication equipment according to the invention only when the parent station calls the child station will now be described in detail by taking a monitor camera system (a supervisory control system) as an example. Although the Internet network or personal computer communications may be used as a network as shown in the first to third embodiments, the following description deals with the case of using the Internet network similarly to the first embodiment.

[0118]

That is, according to the present embodiment, a monitor camera system 51 is used for monitoring an unmanned parking garage, for example, and as shown in Fig. 9, the system includes: a parent station (calling communication equipment) 52 disposed in a head office and a child station (dial-up connection communication equipment) 53 disposed in each parking garage. The child station 53 is provided with a transmitter (child station communicating means) 53a for transmitting a video obtained by a monitor camera 53b ... to the parent station 52, and the video obtained by each monitor camera 53b is sent to a receiver (parent station

communicating means) 52a of the parent station 52 through the transmitter 53a of the child station 53. At the parent station 52, according to the video, whether the presence/absence of parking without permission is confirmed. Thus, all unmanned parking garages over the country can be monitored by only one head office. Accordingly, it is not necessary to dispatch monitoring staff members to the respective parking garages, so that the labor costs can be reduced. The charge of parking is collected once in a week, for example, by a local contracting staff member.

[0119]

To be more precise, the transmitter 53a of the child station 53 has the substantially same configuration as the connector 3a shown in Fig. 1. However, the difference is that in order to control a plurality of monitor cameras 53b, interfaces of the number corresponding to the number of monitor cameras 53b are provided. With this point, a function of recognizing a designation from the parent station 52 to select the monitor camera 53b designated to obtain a video, and designating the monitor camera 53b to obtain a video is assigned to the transmitter. Since the function can be achieved when the CPU 14 shown in Fig. 2 executes a predetermined program, the transmitter 53a can be achieved by the same hardware as that of the connector 3a.

[0120]

Further, each monitor camera 53b is disposed in a position to photograph a number plate of a vehicle parked in each parking space of the parking garage. The resolution of a video obtained by each monitor camera 53b is set to read the characters of the number plate. Each monitor camera 53b and the transmitter 53a are connected by a predetermined communication method as the computer 2b and the connector 2a shown in Fig. 1, whereby the monitor camera 53b can obtain a video according to the designation of the transmitter 53a, and the video data showing the obtained video can be transmitted to the transmitter 53a.

[0121]

Further, in the present embodiment, a wireless telephone system is used in part of the telephone line 54, and the transmitter 53a is connected to the parent station 52 or the provider 56 through a cellular phone set 53c. The wireless telephone system may utilize various systems such as a personal handy phone system (hereinafter referred to as PHS) and an automobile telephone system, and the child station 53 is provided with the cellular phone set 53c according to each system. Similarly to the connector 3a shown in Fig. 1, the transmitter 53a and the telephone line 54 may be directly connected to each other without utilizing the wireless telephone system.

[0122]

Thus, the child station 53 may directly communicate with the parent station 52 through the telephone line 54 similarly to the communication equipment 33 shown in Fig. 1, and it can be connected to the Internet network 57 through the telephone line 54 and the provider 56 by dial-up.

[0123]

On the other hand, the parent station 52 may communicate with the child station 53 by both the direct connection through the telephone line 54 and the connection through the Internet network 57 similarly to the communication equipment 2 shown in Fig. 1. The parent station 52 of the present embodiment is directly connected to the Internet network 57 by a leased line 58 differently from the communication equipment 2. Thus, the parent station 52 may call the child station 53 to communicate therewith using the calling method of the dial-up connection communication equipment according to the invention. Since the parent station 52 of the present embodiment is always connected to the Internet network 57 by the leased line 58, an inherent IP address is assigned to the parent station 52.

[0124]

To be concrete, the parent station 52 of the present embodiment is provided with a receiver 52a instead of the connector 2a shown in Fig. 1, and provided with a terminal 52b instead of the computer 2b and the telephone set 2c, which informs a video from the monitor camera 53b to a user and receives user's designation. The receiver 52a and the terminal 52b are connected by a predetermined communication method such as LAN similarly to the connector 2a and the computer 2b to perform bi-directional transmission and receiving of the data.

[0125]

The receiver 52a of the present embodiment includes a terminal adapter (TA) function, and it can be connected to an ISDN line through a digital line terminal device (DSU) not shown. The ISDN line is a digital line by which two lines (B channel) are simultaneously used by single subscriber contract. One line is monopolized to be connected to the Internet as a leased line 58, and the other line is used as the telephone line 54. The leased line 58 is not limited to this, but various lines such as a cable television line and an optical fiber can be used. When the ISDN line is used, however, both the leased line 58 and the telephone set 54 can be achieved by single subscriber contract, so that the parent station 52 may be achieved comparatively inexpensively.

[0126]

To be concrete, although the receiver 52a has the similar configuration to that of the connector 2a shown in Fig. 2 as shown in Fig. 10, S/T point interface (referred to S/T point I/F for short) 18 connected to the DSU is provided instead of the communicating IC 13. The S/T point I/F 18 can control setting/disconnection (line connection/disconnection) of a call according to the designation of the CPU 14, or convert a data row processed by the CPU 14 and an electric signal transmitted on the ISDN line to and from each other. Further the S/T point I/F 18 also may modulate the data row to be processed by the CPU 14 to a voice signal, and then transmit the voice signal on the ISDN line, demodulate the voice signal transmitted from the ISDN line, and convert it to the data row to be processed by the CPU 14. Thus, the receiver 52a can directly communicate with the transmitter 53a of the child station 53 through the telephone line 54. The communication method between the receiver 52a and the transmitter 53a is serial communication according to predetermined standards such as V32,

V32bis, V34, V21 or V22, which may transmit and receive a message between them.

[0127]

Thus, the receiver 52a may directly call the child station 53 through the telephone line 54 and also communicate with the child station 53 through the leased line 58 and the Internet network 57.

[0128]

If the function as the whole of the parent station 52 is the same, it is possible to freely set the role sharing of the receiver 52a and the terminal 52b and whether or not both of them are integrally formed according to use, but the case where the receiver 52a acts as a server receiving a video from the monitor camera 53b will now be taken as an example and described. In this case, the video from each monitor camera 53b is stored in the receiver 52a, and the terminal 52b designates the receiver 52a to receive the video and display the video. On the other hand, when the user decides to obtain a video of a place where a certain monitor camera 53b is disposed, the terminal 52b discriminates the designation of the user by keying or the like, and informs the receiver 52a of an obtain request for a video to the monitor camera 53b. The receiver 52a discriminates the child station 53 corresponding to the monitor camera 53b according to the information from the terminal 52b, and calls the child station 53 by the calling method of the dial-up connection communication equipment according to the invention.

[0129]

The operation of the parent station 52 and the child station 53 in calling the child station 53 will now be described according to the flowchart shown in Fig. 11. Similarly to the flowcharts of the first to third embodiments, the step showing the operation of the calling, that is, parent station 52 is referred by a reference numeral to which a final letter (a) is added such as S61a, and the step showing the operation of the called, that is, child station 53 is referred by a reference numeral to which a final letter (b) is added.

[0130]

That is, at the parent station 52, the terminal 52b generates a receive request for obtaining a video from the monitor camera 53b according to the designation of the user and informs it to the receiver 52a (S61a). The receiver 52a retrieves the child station 53 corresponding to the monitor camera 53b according to the receive request to obtain the information for calling the child station 53 such as a telephone number and a password. Further, the receiver 52a telephones to the telephone number using a free line out of two ISDN lines to make a phone call to the transmitter 53a of the child station 53 (S62a). When the transmitter 53a responds to a telephone call (S61b), direction communication is enabled between the receiver 52a and the transmitter 53a by the telephone line 54.

[0131]

Further, in the S63a, when the receiver 52a informs the transmitter 53a of a predetermined password, the transmitter 53a verifies whether or not the received password is a predetermined notified password in the S62b, and if it is the notified password, a response

message is transmitted to the receiver 52a.

[0132]

On receiving the response message, the receiver 52a gives a communication parameter (access information) used in connection through the Internet network 57 to the transmitter 53a in the S64a, and after receiving the communication parameter, the transmitter 53a disconnects the line connection with the telephone line 54 (S63b). Thus, the direction connection between the receiver 52a and the transmitter 53a is disconnected.

[0133]

The communication parameter transmitted in the above S64a includes dial-up information used for dial-up connection of the transmitter 53a such as a telephone number of the nearest provider 56 of the transmitter 53a, an account of the provider 56 and a password. The receiver 52a may inform each transmitter 53a of previously associated dial-up information, and for example, the receiver 52a may confirm the position of the transmitter 53a and inform the dial-up information corresponding to the transmitter 53a using the service of the radio communication system for informing both of the calling end and called end of the current position of the terminal.

[0134]

Further, the communication parameter includes the information used in transmitting video data through the Internet network 57 such as a key of cryptograph, the IP address of the receiver 52a, log-in name for ftp (File Transfer Protocol), and a communication start condition. To be more precise, the above key of cryptograph is a key of cryptograph used in enciphering the video data by the transmitter 53a, which is a throwaway type varying with every connection. The communication start condition shows a condition in connecting the transmitter 53a to the receiver 52a through the Internet network 57, and the following conditions are cited. When a first condition is selected, the receiver 52a calls the transmitter 53a on the telephone line 54, and the moment the communication is disconnected, the child station 53 starts the communication. When a second condition is selected, the transmitter 53a automatically starts the communication at fixed time intervals or at a specified time. Further, when a third condition is selected, in the case where some abnormality is sensed by a sensor (not shown) connected to the transmitter 53a, the transmitter 53a automatically starts the communication. In addition, when a fourth condition is selected, the transmitter 53a always performs the image processing for the video from each monitor camera 53b, and in the case where a predetermined change appears in the video, it automatically starts the communication. When a fifth condition is selected, in the case where a call is received from an ordinary telephone set (not shown) through the telephone line 54, the transmitter 53a automatically starts the communication after the connection with the telephone set is disconnected.

[0135]

When direct communication between the receiver 52a and the transmitter 53a is disconnected in the above S63b, the transmitter 53a is on standby until the communication

start conditions informed in the above S64a are satisfied (S64b).

[0136]

When the communication conditions are satisfied, the transmitter 53a designates the monitor camera 53b to take a photograph or selects the latest video from the videos transmitted from the monitor camera 53b to obtain the video data from the monitor camera 53b, and enciphers the same using the key of cryptograph informed in the above S64a. Further, the transmitter 53a is dialed up and connected to the Internet network 57 through the provider 56 specified in the S64a (S65b). Thus, an IP address is assigned and the transmitter 53a is connected to the Internet network 57. The receiver 52a is always connected to the Internet network 57 through the leased line 58.

[0137]

Subsequently, in the S66b, the transmitter 53a causes a request for ftp connection to the receiver 52a through the Internet network 57 (S66b). The ftp connection request is caused by transmitting a predetermined command to the IP address of the receiver 52a informed in the above S64a.

[0138]

Further, on receiving the ftp connection request, the receiver 52a transmits a random number to the transmitter 53a on a login name input screen (S65a). Since the IP address of the transmitter 53a is not determined until it is assigned in the above S65b, the receiver 52a cannot estimate the IP address of the transmitter 53a. However, the datagram, which is transmitted to the receiver 52a when the transmitter 53a causes a request for ftp connection in the above S66b, includes the IP address of the transmitter 53a as an IP address at the transmitting end. Accordingly, the receiver 52a may transmit arbitrary data to the transmitter 53a through the Internet network 57 without any hindrance by transmitting the datagram to the IP address.

[0139]

Further, the transmitter 53a enciphers the received random number using the key of cryptograph informed in the above S64a to generate a password, and transmits the password to the receiver 52a (S67b). On the other hand, the receiver 52a determines whether or not the received password is a password, which corresponds to the login name and is enciphered using the password informed in the above S64a. When it is the password, which corresponds to the login name and is correctly enciphered, the transmitter 53a is acknowledged to be a regular party at the other end (S66a).

[0140]

The acknowledged transmitter 53a transmits the video data enciphered in the above S65b to the receiver 52a by an ftp protocol (S68b). The video data reaches the receiver 52a through the Internet network 57, and the receiver 52a receives the enciphered video data (S67a). Further, at the completion of transmission, the transmitter 53a disconnects the line connection with the provider 56 (S69b). Thus, the communication between the receiver 52a and the transmitter 53a through the Internet network 57 is completed.

[0141]

Further, the receiver 52a telephones the transmitter 53a to confirm whether or not the line connection between the transmitter 53a and the provider 56 is normally disconnected according to a ring tone. To be concrete, the transmitter 53a is set so that when a telephone call is received, call-in does not occur until ring tone is sounded predetermined number of times such as once or twice. As a result, when the receiver 52a calls up the transmitter 53a, ring tone is sounded a predetermined number of times. In the ordinary telephone line 54, the ring tone varies with whether or not the called transmitter 53a is connected to the line. Accordingly, the receiver 52a may confirm whether or not the line connection between the transmitter 53a and the provider 56 is disconnected according to the ring tone.

[0142]

For example, when an ordinary ring tone indicating that the line is not busy is sounded, the receiver 52a determines that the transmitter 53a is correctly disconnected from the Internet network 57. On the other hand, when a tone "a dah dah" indicating that the line is busy rings, the receiver 52a determines that the transmitter 53a is now connected to the Internet network 57. In this case, the receiver 52a transmits a disconnection command or the like to the IP address of the transmitter 53a, which communicated through the Internet network 57 a little while ago, thereby designating line disconnection to the transmitter 53a. In response to the information of the receiver 52a, the user of the terminal 52b may leave for the installation place of the monitor camera 53b to disconnect the line.

[0143]

In either case, the parent station 52 may grasp the failure in disconnection at the child station 53 to take suitable measures. As a result, the generation of wasteful communication cost due to failure in line disconnection can be surely prevented. When the receiver 52a stops a telephone call before the predetermined number of times, the telephone charges is free.

[0144]

In the S69a, the receiver 52a decodes the received video data and transmits the decoded video data to second equipment such as a terminal 52b shown in Fig. 9 by ftp protocol. Thus, the video data is displayed on the terminal 52b, and the user of the terminal 52b may confirm the video of the installation place of the monitor camera 53b.

[0145]

As a result, even when the child station 53 is dialed up and connected, the parent station 52 may confirm the video from the monitor camera 53b at an arbitrary point of time, and when any abnormality is found, such as when parking without permission is found, a specified monitor camera 53b may be monitored as a priority. Accordingly, the parking space where parking without permission is found is surrounded by a fence or information to that effect is given to a security company to take measures corresponding to the abnormality.

[0146]

As described above, the communication equipment constituting the Internet network 57 receives datagram from the neighboring communication equipment regardless of the IP

address of the transmitting communication equipment. Accordingly, the receiver 52a may receive the video data from a plurality of transmitters 53a through the Internet network 57 when the throughput of the receiver 52a and the communication capacity of the leased line 58 are within the limits. Further, the receiver 52a may maintain the connection through the Internet network 57 and the direct connection through the telephone line 54 at the same time. Accordingly, the receiver 52a may dial up to a second transmitter 53a to designate acquisition of a video even while the video data is received through the Internet network 57.

[0147]

The description of the respective steps deals with the case where the video obtained by the monitor camera 53b is transmitted to the receiver 52a through the Internet network 57. When it is difficult to transmit data through the Internet network 57, such as when the provider 56 is congested, the transmitter 53a may dial up the receiver 52a to transmit a video by the direct communication through the telephone line 54. In this case, access to the Internet network 57 and encryption are not needed, so that the transmitter 53a can transmit a video to the receiver 52a at an earlier time.

[0148]

Although the receiver 52a and the transmitter 53a transmit the video data using the ftp protocol in the above respective steps, this is not restrictive. If it is a method of transmitting the data through the Internet network 57, the video data may be transmitted using the other methods such as an electronic mail. According to the ftp protocol, however, it is possible to surely confirm whether or not the data is transmitted by both of the receiver 52a and the transmitter 53a. Therefore, when data transmission fails, it is possible to take suitable measures, such as retransmission of data.

[0149]

Further, although the receiver 52a confirms whether or not the line connection of the transmitter 53a is disconnected according to a ring tone in the above S68a, this is not restrictive. For example, the receiver 52a may dial up to the transmitter 53a to directly communicate with each other, thereby confirming whether or not the line connection is disconnected. In the case of confirming the disconnection of the line according to a ring tone, however, the communication cost is free so that the communication cost can be further reduced as compared with the case of direct communication.

[0150]

An example of cost in managing the monitor camera system 51 will be simply described. In the above monitor camera system 51, since the number plate is confirmed according to the video obtained from the monitor camera 53b, after being compressed, a video with high precision as much as about 500 kilo-byte per sheet is needed. Accordingly, in the case of performing direct communication for the video using ISDN line whose data transmission speed is 64 k bps, it takes about 62 sec to transmit one sheet of video. In this case, when the parent station 52 and the child station 53 are located in Tokyo and Nagoya, respectively, the communication cost is about 40 yen. As a result, supposing that the

frequency of obtaining a video is one time per hour, about 350,400 yen is needed for one year. On calculating the cost in the case of performing direct communication by analog line whose transmission speed is 33.6 kbps under the same conditions, as about 120 sec is needed for one time transmission, the communication cost is about 120 yen per time and about 700,800 yen is needed for one year. In the case of connecting the child station 53 to the Internet network 57 by a leased line, in recent years, about 400,000 yen is needed for using the leased line for one year.

[0151]

On the contrary, in the case of communication through the Internet network 7, when the provider 6 is within the range of speech communication with the child station 53 at the local telephone charge, the time required for one time transmission is within 180 sec, so the communication cost per time is 10 yen and it is about 87,600 yen for one year. Further, when the charge for the provider 6 is about 60,000 yen for one year, the communication cost per year is about 147,600 yen. As a result, in the above monitor camera system 51, the communication cost per child station 53 can be remarkably reduced by about 560,000 yen (about 79%) as compared with that in the case of direct communication using an ordinary line, and by about 200,000 yen (about 57%) as compared with that in the case of ISDN. Further, as the precision and number of sheets of video required by the parent station 52 or the communication frequency increases, the communication cost becomes relatively lower in the monitor camera system 51. On the other hand, as compared with the case where the child station 53 is connected by the leased line, the communication cost per child station 53 can be reduced by about 250,000 yen (about 63%) per year in the monitor camera system 51.

[0152]

The above communication cost is a merely example, so it largely varies with the rate system of the communication line used, and the rate system of the provider 6. As described above, in the respect of equipment required for communication, the communication cost can be easily reduced in the network more than in the communication line. Further, even in the case of communication using the network, the communication cost can be easily reduced in the dial-up connection more than in the connection using the leased line. Thus, the communication cost of the above monitor camera system 51 is often remarkably low as compared with both the case where the child station 53 is connected by the leased line and the case where the parent station 52 and the child station 53 are directly communicated.

[0153]

[Fifth Embodiment]

The description of the fourth embodiment deals with the case where the parent station 52 is always connected to the Internet network 57 by the leased line 58. On the contrary, as shown in Fig. 12, the description of the present embodiment will deal with the case where a parent station 52 is, similarly to the communication equipment 2 shown in Fig. 1, dialed up and connected to the Internet network 57 through a provider 55.

[0154]

The receiver 52a of the present embodiment has the same hardware configuration as that of the fourth embodiment, so that in communicating with a child station 53, one of two ISDN lines is used to achieve dial-up connection to the provider 55. The other components of the monitor camera system 51 such as the child station 53 have the same construction as that of the fourth embodiment. Therefore, the members having the same functions as those of the fourth embodiment are designated by the same reference numerals to omit the description. The operation of the parent station 52 and the child station 53 will now be described in detail according to the flowchart shown in Fig. 13.

[0155]

In the present embodiment, in addition to the steps shown in Fig. 11, both steps S71a and S72a are provided. In the S71a provided after the S61a, the receiver 52a is dialed up and connected to the Internet network 57 through the provider 55 when it is not connected to the Internet network 57. Thus, the receiver 52a can obtain its own IP address informed in the subsequent S64a.

[0156]

The receiver 52a is connected to the ISDN line. Accordingly, in the above S62a, while the receiver 52a is still connected to the Internet network 57, it may call a transmitter 53a using the other line. As a result, the IP address assigned to the receiver 52a in the above S71a is assigned to the receiver 52a after the S64b as well.

[0157]

On the other hand, in the S72a provided after S67a, the receiver 52a disconnects the line connection from the provider 55. Thus, the receiver 52a is disengaged from the Internet network 57.

[0158]

In the above configuration, the receiver 52a is dialed up and connected to the Internet network 57. Accordingly, as compared with the fourth embodiment in which the receiver 52a is connected by the leased line 58, the communication cost can be further reduced.

[0159]

In the above configuration, when the second to fifth conditions that the receiver 52a cannot manage the communication start point are selected among the communication start conditions informed in the above S64a, sometimes the receiver 52a is not connected to the Internet network 57 in transmitting a video by the transmitter 53a. Accordingly, in the case of selecting these conditions, the transmitter 53a has to call the receiver 52a using the calling method of dial-up connection communication equipment according to the invention. In this case, the receiver 52a and the transmitter 53a inform the party at the other end of its own IP address using an electronic mail or through a server as shown in the first and second embodiments.

[0160]

Although the description of the fourth and fifth embodiments deals with the case where photographing is designated to the monitor camera of the unmanned parking garage to

obtain a photographed video as an application example of a monitor camera system, the monitor camera system of the invention is not limited to this, but it may be used in various purposes. For example, when the monitor camera is disposed in buildings and warehouses possessed in various places all over the country, the management firms may monitor the buildings and warehouses from one office as the parent station. Similarly, it may be applied to the purpose for monitoring unmanned shops and unmanned convenience store in a drive-in from a head office. Further, it may be used when a banking agency manages unmanned shop or an electric company manages an unmanned transformer substation or dam at remote places from a head office. Further, when the monitor camera is disposed in a delivery place, the condition of the delivery place can be known at the head office of a device maker, so that the monitor camera can be made useful for remote maintenance for delivered devices. When the unmanned cameras are disposed in volcanoes of various places, the volcanic activities of these may be monitored from the Research Laboratories of the Universities. The monitor cameras are disposed in the first-food shops, restaurants and convenience chain stores and the data obtained by photographing the respective interiors of the stores are transmitted to the head office, whereby various market information pieces such as customer attendance, the number of customers, constitution, age group or seated places by each time zone, can be acquired at the head office.

[0161]

In either case, it is not necessary to dispatch a monitoring staff member, so that the labor costs can be reduced. In addition, the monitor data can be transmitted through a network such as the Internet so that the communication cost can be remarkably reduced as compared with the case of using the communication line such as a telephone line. Further, since the monitor camera is called by the communication line, the parent station may designate the monitor camera to acquire a video at a desired point of time. As a result of these, it is possible to achieve the monitor camera system, which may acquire a video at an arbitrary point of time at a little budget.

[0162]

Although the description of the fourth and fifth embodiments deals with the case where a controlled system of the child station 53 is the monitor camera 53b, this is not restrictive. The invention may be applied to the monitor control system in which various pieces of equipment are controlled systems such as the case where the child station 53 transmits the data acquired using various sensors to the parent station 52, or the case where the child station 53 controls a motor and a pump according to the designation of the parent station 52. However, when the amount of data transmitted is large as in the case where the monitor camera 53b transmits the acquired video, the time required for communication is long so that when the data is transmitted by direct communication using the communication line, the communication cost rises sharply. Therefore, the effect in applying the invention to the monitor camera system 51 especially becomes larger.

[0163]

As shown in the first to fifth embodiments, respectively, the calling method of dial-up connection communication equipment is the calling method applied to the communication system in which the calling communication equipment and called communication equipment are respectively connected to the telephone line, and at least the called communication equipment is dialed up and connected to the network such as the Internet network and personal computer communications through the telephone line, and it is characterized in that before communication through the network, the calling communication equipment transmits a connection request to the called communication equipment using the telephone line.

[0164]

Thus, even when the called communication equipment is not connected to the network, in communication through the network, the called communication equipment can be connected to the network. Accordingly, both of communication equipment may surely start the communication in a desired timing. Thus, as compared with the prior art, the quick responsiveness of the called communication equipment can be improved to achieve real-time communication.

[0165]

Further, at least the called communication equipment is dialed up and connected to the network. Therefore, the cost in communication through the network can be remarkably reduced as compared with the case of connection to the network through the leased line and the case of direct communication through the telephone line. Especially, in the case where there is a long way between the places for installing both of communication equipment as in the foreign countries or the like, the cost in the case of direct communication through the telephone line is very high, so the effect of the invention is great.

[0166]

Although the description of the respective embodiments deals with the case where both of communication equipment are dialed up and connected, this is not restrictive. As in the fourth embodiment, for example, when at least the called communication equipment is the dial-up connected communication system, the same effect as those of the first to fifth embodiments can be obtained.

[0167]

Although the calling communication equipment informs a connection request by the telephone line in the above respective embodiments, this is not restrictive. The other communication lines such as a harbor radio may be used. When the equipment can inform a connection request to the called end, the same effect as those of the respective embodiments can be obtained.

[0168]

Although the description of the respective embodiments deals with the case where the calling communication equipment calls one piece of communication equipment, this is not restrictive, but two or more pieces of communication equipment may be called. Similarly to the case of calling one piece of communication equipment, two or more pieces of

communication equipment are called in order by the telephone line, whereby a number of pieces of communication equipment can communicate at the same time on the network. In this case, the user of the calling communication equipment is a convener of a conference. In this case, network conferencing software enabling two or more pieces of communication equipment to communicate at the same time is needed, but generally this type of product has been already used.

[0169]

Although the communication equipment of each embodiment enciphers at least part of data transmitted by the network such as the user name and the communication contents, this is not restrictive. In communication through the network, the data may be transmitted still in the plaintext without enciphering.

[0170]

In the case of transmitting the data still in the plaintext, however, there is the risk that the data transmitted through the network is tapped or altered. Especially, in the case of using the Internet network as the network, the transmitting communication equipment and the receiving communication equipment cannot specify a data transmission channel. Consequently, wiretapping is easy so that the risk of communication jamming is high.

[0171]

On the contrary, in the above respective embodiments, in transmitting the data through the network, at least part of data is enciphered by various keys of cryptograph such as a public key of the party at the other end and a common key of cryptograph. Thus, at least part of the data can be concealed from a third party, which is not a regular communication party, so that the security to communication jamming can be improved.

[0172]

As the data to be enciphered, cited are the communication content itself, and user names and addresses of both communication equipment. As the amount of data to be enciphered increase, the load of both communication equipment increase, so only part of data may be enciphered in consideration of significance of communication. Generally, when the user name and address are heard by a third party, the significance of the communication content is easily estimated. Accordingly, as shown in the first and second embodiments, in the case of transmitting the user name and address prior to the communication of an image and a voice, especially preferably these are enciphered. Thus, the security to communication jamming can be improved without much increase in load of both of communication equipment.

[0173]

As a method in which each communication equipment obtains a key of cryptograph, various methods are considered. The key of cryptograph may be previously informed to the party at the other end by the other communication means such as by mail, and stored in storage means of each communication equipment such as the flash memory 11 shown in Fig. 2. In this case, however, the user of each of communication equipment has to set the key of

cryptograph informed from the party at the other end to each of communication equipment prior to communication. Since the key of cryptograph is provided for every communication equipment, as the communication party at the other end is increased in number, the time and trouble for setting is increased. Further, the key of cryptograph should be changed at need to improve the security to communication jamming. Accordingly, the user of each of communication equipment has to inform a new key of cryptograph to all of the parties at the other end every time its own key of cryptograph is changed.

[0174]

On the contrary, according to the above respective embodiments, the key of cryptograph is informed through the communication line at the time of causing a connection request. When the key of cryptograph includes a public key and a privacy key, the public keys are exchanged through the communication line. On the other hand, in the case of using the common public key, it will be sufficient that the communication equipment at one end informs it to the other communication equipment. In this configuration, the key of cryptograph is informed at every connection request, so that even when the key of cryptograph is changed from that in the preceding communication, correction is easy. Accordingly, the key of cryptograph can be easily changed at every connection request, so that the security to communication jamming can be further improved. In addition, both notification of a connection request and sending of a key of cryptograph are performed in a batch using the telephone line. Thus, as compared with the case of individually performing both of them, the time and trouble for connecting the telephone line can be reduced.

[0175]

Further, the key of cryptograph and the enciphered data are transmitted by separate communication means. Accordingly, when a third party attempts to cause communication jamming, it is necessary to tap both of communications, so that the security to communication jamming can be more improved as compared with the case of transmitting the key of cryptograph and the data by single communication means. As the communication line, it is preferable to use the communication line comparatively hard to hear such as the telephone line for preventing wiretapping of the key of cryptograph.

[0176]

In the case where both of communication equipment communicate with each other through a server provided on the network as in the second embodiment, in addition to the above, it is necessary that both of communication equipment register the identifications in the server, and both of communication equipment inform the identification of the party at the other end to the server to select the communication party at the other end.

[0177]

In this case, the identification registered in the server is open to the public, so that when the user name is registered intact, there is the risk of lowering the security to communication jamming. Further, it takes time and trouble to select a desired identification among the identifications registered in the server. In this case, it will be sufficient that the

above public key is used to encipher the user name and register it in the server. Thus, the user name can be concealed from a third party.

[0178]

In the configuration where the server is provided as in the second embodiment, the cost for separately providing the server and maintenance cost are needed. Further, when the server is congested, there is the risk of disabling both of communication equipment from communicating.

[0179]

On the contrary, the first embodiment provides a method in which both of communication equipment can directly communicate with each other through the network differently from the second embodiment. To be concrete, the method includes a process in which in dial-up connection, the called communication equipment acquires its own address, and transmits it to the calling communication equipment by an electronic mail. Thus, differently from the second embodiment, both of communication equipment can communicate through the network without especially providing a server. As a result, the cost required for communication can be further reduced. Further, both of communication equipment can surely communicate regardless of congestion of the server.

[0180]

When the communication through the network is ended, the dial-up connection communication equipment is disconnected from the network. In this case, when the dial-up connection communication equipment fails in line disconnection from the network, the dial-up connection communication equipment is continuously connected to the network, so that the communication cost rises sharply as undesired. Especially, when a user is absent in the periphery of the dial-up connection communication equipment, for example, when the dial-up connection communication equipment is the child station of the monitor control system, failure in line disconnection is hardly grasped. Consequently, when failure in line disconnection occurs, the period of time the dial-up connection communication equipment is connected to the network as undesired is apt to be long so that there is a large risk of increasing the wasteful communication cost.

[0181]

On the contrary, as in the fourth and fifth embodiments, the calling communication equipment calls the dial-up connection communication equipment through the communication line after the end of communication through the network to confirm whether or not the dial-up connection is normally disconnected. As a result, the wasteful communication cost due to failure in line disconnection can be reduced.

[0182]

As one example of a communication system to which the calling method of dial-up connection communication equipment according to the invention is applied, the description of the first to third embodiments deal with the Internet telephone system in which a video and a voice are transmitted, and the description of the fourth and fifth embodiments deals with the

supervisory control system such as the monitor camera system. This is, however, not restrictive. The Internet VPN (Virtual Private Network) is constructed and widely applied in the case of transmitting and receiving arbitrary data.

[0183]

By using the calling method of the dial-up connection communication equipment, the communication can be started in a desired timing, and also the communication system, which may reduce the communication cost can be constructed, so that when the quick responsiveness is strongly demanded as in the Internet telephone system and the supervisory control system, especially it is preferable.

[0184]

To be concrete, in the supervisory control system, generally the child station is installed in a place remote from the parent station, and the parent station supervises and control a number of child stations. Consequently, the cost in communication between the parent station and the child stations is apt to increase, so the reduction of the communication cost is strongly demanded. On the other hand, in the supervisory control system, a delay of designation is directly connected with escalation of an accident, so that the child station has to immediately respond to designation of the parent station. Consequently, when the child station communicates with the parent station only through the dialed-up and connected network, the child station cannot respond to the designation of the parent station, resulting in the risk of escalating an accident. As a result of these, in the supervisory control system, it is strongly requested to reduce the communication cost while maintaining the quick responsiveness of the child station to the designation of the parent station. Therefore, when the parent station calls the child station, the application of the calling method of the dial-up connection communication equipment according to the invention is especially effective.

[0185]

[Advantage of the Invention]

According to the invention of claim 1, the calling method of the dial-up connection communication equipment, as described above, includes: a first process in which the calling communication equipment transmits a connection request to the dial-up connection communication equipment by the communication line provided separately from the network and capable of calling the dial-up connection communication equipment; a second process in which the dial-up connection communication equipment receiving the connection request is connected to the network by dial-up; and a third process in which the calling communication equipment and the dial-up connection communication equipment communicate with each other through the network.

[0186]

In the above constitution, even when the dial-up connection communication equipment is not connected to the network, in communication in the third process, the dial-up connection communication equipment can be connected to the network. Therefore, the invention produces the effect of surely starting the communication in a desired timing and

achieving real-time communication in the dial-up connection communication equipment, which may communicate at a low rate.

[0187]

According to the invention of claim 2, in the calling method of the dial-up connection communication equipment, as described above, in the constitution of the invention described in claim 1, the third process includes: an encipher process in which the transmitting communication equipment between the calling communication equipment and the dial-up connection communication equipment enciphers and transmits at least part of the data transmitted in the third process; and a decoding process in which the receiving communication equipment decodes the enciphered data.

[0188]

In the above constitution, at least part of the communication content is concealed from a third party other than the calling communication equipment and the dial-up connection communication equipment by encryption. As a result, the invention produces the effect of improving the security to communication jamming as compared with the case of transmitting the communication content still in a plaintext without enciphering.

[0189]

According to the invention of claim 3, in the calling method of the dial-up connection communication equipment, in the constitution of the invention described in claim 2, the first process includes: a process in which the calling communication equipment or the dial-up connection communication equipment informs the party at the other end of a key of cryptograph used in encipher.

[0190]

In the above constitution, both notification of a connection request and sending of a key of cryptograph are performed in a batch. Thus, the invention produces the effect of transmitting the key of cryptograph at every connection without any increase in time and trouble for connecting the communication line, and reducing the time and trouble when the key of cryptograph is changed.

[0191]

Further, the key of cryptograph and the enciphered data are transmitted by separate communication means. As a result, the effect of further improving the security to communication jamming such as wiretapping and alteration of data is also produced.

[0192]

According to the invention of claim 4, in the calling method of the dial-up connection communication equipment, as described above, in the constitution of the invention described in claim 1, 2 or 3, the third process includes: a process in which both of the above communication equipment inform the sever of their own identifications; a process in which both of the above communication equipment inform the server of the identification of the party at the other end to select the communication equipment of the party at the other end; and a process in which the server relays the communication between the selected communication

equipment.

[0193]

Therefore, the invention produces the effect that both of communication equipment may surely start the communication in a desired timing through the server provided on the network to achieve real-time communication.

[0194]

According to the invention of claim 5, in the calling method of the dial-up connection communication equipment, as described above, in the constitution of the invention described in claim 1, 2 or 3, the third process includes: a process in which the dial-up connection communication equipment obtains its own address in the current connection; a process in which the dial-up connection communication equipment informs the calling communication equipment of its own address by an electronic mail; and a process in which the calling communication equipment and the dial-up connection communication equipment specify the party at the other end by mutual addresses to communicate with each other.

[0195]

Therefore, both of communication equipment may communicate through the network without especially providing the server as in the constitution of claim 4. As a result, in addition to the effect of the invention described in claim 4, the invention produces the effect of further reducing the cost required for communication and surely performing communication regardless of congestion of the server.

[0196]

According to the invention of claim 6, as described above, in the constitution of the invention described in claim 1, 2, 3, 4 or 5, the calling method of the dial-up connection communication equipment further includes: a fourth process in which the calling communication equipment directly calls the dial-up connection communication equipment by the communication line to confirm whether or not the dial-up connection communication equipment normally disconnects the line from the communication line, after the third process.

[0197]

Therefore, the invention produces the effect that the calling communication equipment can surely recognize failure in line disconnection of the dial-up connection communication equipment to surely prevent the generation of wasteful communication cost due to failure in line disconnection.

[0198]

According to the invention of claim 7, the supervisory control system is, as described above, configured so that the parent station includes: the parent station communication means for calling the child station through a ring enable communication line to transmit a connection request, and then communicating with the child station through a network provided separately from the communication line, and the child station includes: the child station communication means connected to the network by dialing up it on receiving the connection request through the communication line to communicate with the parent station through the network.

[0199]

In the above constitution, after the parent station communication means calls the child station using a ring enable communication line, the child station communication means is connected to the network by dial-up connection which enables communication at a low rate to transmit and receive the data through the network. As a result, the invention produces the effect of achieving the supervisory control system, which may remarkably reduce the communication cost between the child station and the parent station, while the child station can immediately respond to the designation of the parent station.

[Brief Description of the Drawings]

[Fig. 1] Fig. 1 is a block diagram showing the configuration of the principal part of the whole communication system according to one embodiment of the invention.

[Fig. 2] Fig. 2 is a block diagram showing the configuration of the principal part of a connector provided on the calling and called communication equipment of the above communication system.

[Fig. 3] Fig. 3 is a block diagram showing the connecting relationship of communication equipment according to one embodiment of the invention.

[Fig. 4] Fig. 4 is a flowchart showing the operation of both of calling and called communication equipment in calling in the above communication system.

[Fig. 5] Fig. 5 is a block diagram showing the configuration of principal part of the whole communication system according to another embodiment of the invention.

[Fig. 6] Fig. 6 is a flowchart showing the operation of both the calling end and the called end in calling in the above communication system.

[Fig. 7] Fig. 7 is a block diagram showing the configuration of the principal part of the whole communication system according to still another embodiment of the invention.

[Fig. 8] Fig. 8 is a flowchart showing the operation of both the calling end and the called end in calling in the communication system.

[Fig. 9] Fig. 9 is a block diagram showing the configuration of the principal part of a supervisory control system according to still another embodiment of the invention.

[Fig. 10] Fig. 10 is a block diagram showing the configuration of the principal part of a receiver in the above supervisory control system.

[Fig. 11] Fig. 11 is a flowchart showing the operation when the parent station calls the child station in the above supervisory control system.

[Fig. 12] Fig. 12 is a block diagram showing the configuration of the principal part of a supervisory control system according to still another embodiment.

[Fig. 13] Fig. 13 is a flowchart showing the operation when the parent station calls the child station in the supervisory control system.

[Description of the Reference Numerals and Signs]

2, 22, 32, 42: communication equipment

3, 33, 43: communication equipment (dial-up connection communication equipment)

4, 34, 44, 54: telephone line (communication line)

7, 37, 57: Internet network (network)

38: server

48, 58: line (network)

52: parent station (communication equipment)

52a: receiver (parent station communication means)

53: child station (dial-up connection communication equipment)

53a: transmitter (child station communication means)

FIG. 1:
U.S.A
JAPAN
2a: CONNECTOR
3a: CONNECTOR
4: TELEPHONE LINE
5, 6: PROVIDER
7: INTERNET NETWORK

FIG. 2:
TO TELEPHONE SET
TO COMPUTER
4: TELEPHONE LINE
11: FLASH MEMORY
12: INTERFACE PART
13: COMMUNICATING IC
16: STATUS DISPLAY LIQUID CRYSTAL PANEL

FIG. 3:
4: TELEPHONE LINE
22a: CONNECTOR

FIG. 4:
- PROCESSING OF COMMUNICATION EQUIPMENT 2
START
S1a: CALL THE COMMUNICATION EQUIPMENT 3 ON THE PHONE.
S2a: TRANSMIT PASSWORD, ELECTRONIC MAIL ADDRESS AND PUBLIC KEY OF
COMMUNICATION EQUIPMENT 2.
S3a: RECEIVE MESSAGE OF THE PARTY AT THE OTHER END.
S4a: DISCONNECT THE PHONE.
S5a: DIAL-UP CONNECTION
S6a: START NETWORK CONFERENCING SOFTWARE.
S7a: ACQUIRE ITS OWN IP ADDRESS.
S8a: TRANSMIT ELECTRONIC MAIL IN WHICH ITS OWN IP ADDRESS IS
ENCIPHERED.
S9a: DECODE IP ADDRESS OF THE PARTY AT THE OTHER END.
S10a: NETWORK CONFERENCE
S11a: DISCONNECT DIAL-UP CONNECTION.
END

- PROCESSING OF COMMUNICATION EQUIPMENT 3

S1b: RECEIVE WAIT, ON

S2b: RESPONSE ON THE PHONE.

S3b: THE PARTY AT THE OTHER END IS VERIFIED?

S4b: CONNECT THE TELEPHONE SET.

S5b: TRANSMIT A CONNECT ENABLE MESSAGE, AND PUBLIC KEY AND ELECTRONIC MAIL ADDRESS OF COMMUNICATION EQUIPMENT 3.

S6b: DISCONNECT THE PHONE.

S7b: DIAL-UP CONNECTION

S8b: START NETWORK CONFERENCING SOFTWARE.

S9b:

ACQUIRE ITS OWN IP ADDRESS.

S10b: TRANSMIT ELECTRONIC MAIL IN WHICH ITS OWN IP ADDRESS IS ENIPHERED.

S11b: DECODE IP ADDRESS OF THE PARTY AT THE OTHER END.

S12b: NETWORK CONFERENCE

S13b: DISCONNECT DIAL-UP CONNECTION.

FIG. 5:

U.S.A.

JAPAN

32a: CONNECTOR

33a: CONNECTOR

34: TELEPHONE LINE

35, 36: PROVIDER

37: INTERNET NETWORK

38: SERVER

FIG. 6:

- PROCESSING OF COMMUNICATION EQUIPMENT 32

START

S21a: CALL THE COMMUNICATION EQUIPMENT 33 ON THE PHONE.

S22a: TRANSMIT PASSWORD AND PUBLIC KEY OF COMMUNICATION EQUIPMENT 32.

S23a: RECEIVE MESSAGE OF THE PARTY AT THE OTHER END.

S24a: DISCONNECT THE PHONE.

S25a: DIAL-UP CONNECTION

S26a: START NETWORK CONFERENCING SOFTWARE.

S27a: ACQUIRE ITS OWN IP ADDRESS.

S28a: ENIPHER ITS OWN IDENTIFICATION AND REGISTER IT IN SERVER.

S29a: SELECT THE IDENTIFICATION OF THE PARTY AT THE OTHER END.
S30a: NETWORK CONFERENCE
S31a: DISCONNECT DIAL-UP CONNECTION.
END

- PROCESSING OF COMMUNICATION EQUIPMENT 33

S21b: RECEIVE WAIT, ON
S22b: RESPONSE ON THE PHONE.
S23b: THE PARTY AT THE OTHER END IS VERIFIED?
S24b: CONNECT THE TELEPHONE SET.
S25b: TRANSMIT A CONNECT ENABLE MESSAGE, AND PUBLIC KEY OF
COMMUNICATION EQUIPMENT 33.
S26b: DISCONNECT THE PHONE.
S27b: DIAL-UP CONNECTION
S28b: START NETWORK CONFERENCING SOFTWARE.
S29b: ACQUIRE ITS OWN IP ADDRESS.
S30b: ENCIPHER ITS OWN IDENTIFICATION AND REGISTER IT IN SERVER.
S31b: SELECT THE IDENTIFICATION OF THE PARTY AT THE OTHER END.
S32b: NETWORK CONFERENCE
S33b: DISCONNECT DIAL-UP CONNECTION.

FIG. 7:

U.S.A

JAPAN

42a, 43a: CONNECTOR

44: TELEPHONE LINE

45, 46: ACCESS POINT

47: PERSONAL COMPUTER COMMUNICATIONS SERVER

FIG. 8:

- PROCESSING OF COMMUNICATION EQUIPMENT 42

START

S41a: CALL THE COMMUNICATION EQUIPMENT 43 ON THE PHONE.
S22a: TRANSMIT PASSWORD AND PUBLIC KEY OF COMMUNICATION EQUIPMENT
42.
S43a: RECEIVE MESSAGE OF THE PARTY AT THE OTHER END.
S44a: DISCONNECT THE PHONE.
S45a: DIAL-UP CONNECTION
S46a: START NETWORK CONFERENCING SOFTWARE.
S47a: ENCIPHER THE COMMUNICATION CONTENT BY NETWORK

CONFERENCING SOFTWARE AND COMMUNICATE.

S48a: DISCONNECT DIAL-UP CONNECTION.

END

- PROCESSING OF COMMUNICATION EQUIPMENT 43

S41b: RECEIVE WAIT, ON

S42b: RESPONSE ON THE PHONE.

S43b: THE PARTY AT THE OTHER END IS VERIFIED?

S44b: CONNECT THE TELEPHONE SET.

S45b: TRANSMIT A CONNECT ENABLE MESSAGE, AND PUBLIC KEY OF COMMUNICATION EQUIPMENT 43.

S46b: DISCONNECT THE PHONE.

S47b: DIAL-UP CONNECTION

S48b: START NETWORK CONFERENCING SOFTWARE.

S49b: ENCIPHER THE COMMUNICATION CONTENT BY NETWORK CONFERENCING SOFTWARE AND COMMUNICATE.

S50b: DISCONNECT DIAL-UP CONNECTION.

FIG. 9:

52a: RECEIVER

53a: TRANSMITTER

54: TELEPHONE LINE

56: PROVIDER

57: INTERNET NETWORK

FIG. 10:

TO ISDN LINE THROUGH DSU.

TO COMPUTER.

11: FLASH MEMORY

12: INTERFACE PART

13: S/T POINT I/F

16: STATUS DISPLAY LIQUID CRYSTAL PANEL

FIG. 11:

- PROCESSING OF PARENT STATION

START

S61a: CAUSE A RECEIVE REQUEST.

S62a: CALL TRANSMITTER ON THE PHONE.

S63a: INFORM PASSWORD.

S64a: INFORM COMMUNICATION PARAMETER.

S65a: TRANSMIT RANDOM NUMBER TO TRANSMITTER ON LOGIN NAME INPUT SCREEN.

S66a: ACKNOWLEDGE TRANSMITTER BY PASSWORD.

S67a: RECEIVE ENCIPHERED VIDEO DATA.

S68a: CALL TRANSMITTER ON THE PHONE, AND CONFIRM LINE DISCONNECTION ACCORDING TO RING TONE.

S69a: DECODE VIDEO DATA.

END

-PROCESSING OF CHILD STATION

S61b: RESPONSE ON THE PHONE.

S62b: VERIFY PASSWORD, AND TRANSMIT RESPONSE MESSAGE.

S63b: RECEIVE COMMUNICATION PARAMETER AND DISCONNECT THE PHONE.

S64b: WAIT FOR COMMUNICATION START CONDITION.

S65b: ACQUIRE A VIDEO, ENCIPHER AND DIAL-UP CONNECTION.

S66b: ftp CONNECTION REQUEST TO RECEIVER.

S67b: TRANSMIT PASSWORD CREATED BY ENCIPHERING RANDOM NUMBER TO RECEIVER.

S68b: TRANSMIT ENCIPHERED VIDEO DATA.

S69b: DISCONNECT DIAL-UP CONNECTION.

END

FIG. 12:

52a: RECEIVER

53, 53a: TRANSMITTER

54: TELEPHONE LINE

55, 56: PROVIDER

57: INTERNET NETWORK

FIG. 13:

- PROCESSING OF PARENT STATION

START

S61a: CAUSE A RECEIVE REQUEST.

S71a: DIAL-UP CONNECTION

S62a: CALL TRANSMITTER ON THE PHONE.

S63a: INFORM PASSWORD.

S64a: INFORM COMMUNICATION PARAMETER.

S65a: TRANSMIT RANDOM NUMBER TO TRANSMITTER ON LOGIN NAME INPUT SCREEN.

S66a: ACKNOWLEDGE TRANSMITTER BY PASSWORD.

S67a: RECEIVE ENCIPHERED VIDEO DATA.
72a: DISCONNECT DIAL-UP CONNECTION.
S68a: CALL TRANSMITTER ON THE PHONE, AND CONFIRM LINE
DISCONNECTION ACCORDING TO RING TONE.
S69a: DECODE VIDEO DATA.
END

-PROCESSING OF CHILD STATION

S61b: RESPONSE ON THE PHONE.
S62b: VERIFY PASSWORD, AND TRANSMIT RESPONSE MESSAGE.
S63b: RECEIVE COMMUNICATION PARAMETER AND DISCONNECT THE PHONE.
S64b: WAIT FOR COMMUNICATION START CONDITION.
S65b: ACQUIRE A VIDEO, ENCIPHER AND DIAL-UP CONNECTION.
S66b: ftp CONNECTION REQUEST TO RECEIVER.
S67b: TRANSMIT PASSWORD CREATED BY ENCIPHERING RANDOM NUMBER TO
RECEIVER.
S68b: TRANSMIT ENCIPHERED VIDEO DATA.
S69b: DISCONNECT DIAL-UP CONNECTION.
END

(19) 日本国特許庁 (J P)

(12) 公開特許公報 (A)

(11) 特許出願公開番号

特開平10-155040

(43) 公開日 平成10年(1998) 6月9日

(51) Int.Cl. ⁸	識別記号	F I
H 0 4 M 11/00	3 0 3	H 0 4 M 11/00 3 0 3
H 0 4 L 9/08		1/66 A
	9/32	3/42 T
	12/02	H 0 4 Q 9/00 3 1 1 W
	12/54	H 0 4 L 9/00 6 0 1 F

審査請求 未請求 請求項の数7 O L (全 30 頁) 最終頁に続く

(21) 出願番号	特願平9-264639	(71) 出願人	000003942 日新電機株式会社 京都府京都市右京区梅津高畝町47番地
(22) 出願日	平成9年(1997) 9月29日	(72) 発明者	小野 泰正 京都府京都市右京区梅津高畝町47番地 日新電機株式会社内
(31) 優先権主張番号	特願平8-259921	(74) 代理人	弁理士 原 謙三
(32) 優先日	平8(1996) 9月30日		
(33) 優先権主張国	日本 (J P)		

(54) 【発明の名称】 ダイアルアップ接続通信機器の呼び出し方法、および、それを用いた監視制御システム

(57) 【要約】

【課題】 インターネット網へダイアルアップ接続する通信機器を確実に呼び出し、安全にリアルタイム双方向通信できる呼び出し方法を提供する。

【解決手段】 通信機器2は、電話回線4を介して通信機器3を呼び出し、接続要求と自らの公開鍵とを通信機器3へ伝える。一方、通信機器3は、自らの公開鍵を通信機器2へ送出する。その後、両通信機器2・3は、電話回線4を一度切断し、近隣のプロバイダ5・6を呼び出して、インターネット網7にそれぞれ接続する。両通信機器2・3は、現接続時における自らのIPアドレスを相手の公開鍵で暗号化し、電子メールとして、相手の電子メールアドレスへ送信する。各通信機器2・3は、受信した電子メールを自らの秘密鍵で復号して、相手のIPアドレスを確認する。その後、両通信機器2・3は、当該IPアドレスを用いて、インターネット網7で通信する。

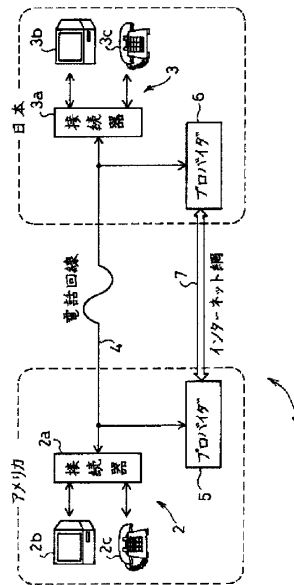

【特許請求の範囲】

【請求項1】 ネットワークへダイヤルアップ接続されるダイヤルアップ接続通信機器の呼び出し方法であって、上記ネットワークとは別に設けられ、上記ダイヤルアップ接続通信機器を呼び出し可能な通信回線によって、発呼側の通信機器がダイヤルアップ接続通信機器へ接続要求を伝える第1工程と、

接続要求を受けたダイヤルアップ接続通信機器が、上記ネットワークへダイヤルアップ接続する第2工程と、上記ネットワークを介して、発呼側の通信機器とダイヤルアップ接続通信機器とが通信する第3工程とを含んでいることを特徴とするダイヤルアップ接続通信機器の呼び出し方法。

【請求項2】 上記第3工程は、上記発呼側の通信機器およびダイヤルアップ接続通信機器のうち送信側の通信機器が、当該第3工程にて送出するデータの少なくとも一部を暗号化して送出する暗号工程と、受信側の通信機器が、暗号化されたデータを復号する復号工程とを含んでいることを特徴とする請求項1記載のダイヤルアップ接続通信機器の呼び出し方法。

【請求項3】 上記第1工程は、発呼側の通信機器あるいはダイヤルアップ接続通信機器が、暗号化の際に使用される暗号鍵を相手に通知する工程を含んでいることを特徴とする請求項2記載のダイヤルアップ接続通信機器の呼び出し方法。

【請求項4】 上記ネットワークには、発呼側の通信機器とダイヤルアップ接続通信機器との間の通信を中継するサーバが設けられており、

上記第3工程は、上記両通信機器が、自らを示す登録名を上記サーバへそれぞれ通知する工程と、上記両通信機器が、相手の登録名を上記サーバへ通知して、相手の通信機器を選択する工程と、上記サーバか選択された通信機器間の通信を中継する工程とを含んでいることを特徴とする請求項1、2または3記載のダイヤルアップ接続通信機器の呼び出し方法。

【請求項5】 上記ネットワークは、データを伝送する際、当該ネットワークにおけるアドレスによって送信先を特定すると共に、

ダイヤルアップ接続通信機器に対して、接続毎に臨時のアドレスを割り当てるネットワークであり、上記第3工程は、ダイヤルアップ接続通信機器が、現接続における自らのアドレスを取得する工程と、

電子メールによって、ダイヤルアップ接続通信機器が、発呼側の通信機器へ自らのアドレスを通知する工程と、発呼側の通信機器およびダイヤルアップ接続通信機器が、自らのアドレスにより相手特定して通信する工程とを含んでいることを特徴とする請求項1、2または3記載のダイヤルアップ接続通信機器の呼び出し方法。

【請求項6】 さらに、上記第3工程の後で、上記発呼側の通信機器がダイヤルアップ接続通信機器を上記通信回

線にて直接呼び出して、当該ダイヤルアップ接続通信機器が当該通信回線との回線接続を正常に切断したか否かを確認する第4工程を含んでいることを特徴とする請求項1、2、3、4または5記載のダイヤルアップ接続通信機器の呼び出し方法。

【請求項7】 設備機器を有する子局と、当該子局との通信によって上記設備機器を制御する親局とを備えた監視制御システムにおいて、

上記親局は、呼び出し可能な通信回線を介して上記子局を呼び出し、接続要求を伝えた後で、上記通信回線とは別に設けられたネットワーク経由で上記子局と通信する親局通信手段を備え、

上記子局は、上記通信回線を介して、上記接続要求を受け取った後で、上記ネットワークにダイヤルアップ接続して、当該ネットワーク経由で上記親局と通信する子局通信手段を備えていることを特徴とする監視制御システム。

【発明の詳細な説明】

【0001】

【発明の属する技術分野】 本発明は、例えば、ダイヤルアップ接続によって、インターネット網に接続される通信機器など、必要ときにネットワークに接続されるダイヤルアップ接続通信機器の呼び出し方法、および、それを用いた監視制御システムに関するものである。

【0002】

【従来の技術】 通信手段の1つとして、公衆電話回線網は、従来より広く用いられている。この公衆電話回線網では、通信に先立って、ネットワーク側が発呼側と被呼側との間でコネクション（論理的な通信パス）を確保して、被呼側を呼び出す。このようなコネクション型の通信システムでは、通信路が長い程、コネクションの確立が困難になる。したがって、公衆電話回線網は、一般に、通信距離に応じた料金体系を採用している。

【0003】 一方、近年では、新たな通信手段として、インターネット網が急速に普及しつつある。インターネット網の場合、送信側の通信機器は、データを送信する際に、データ列を所定の大きさに毎に区切ってデータグラムを作成し、近隣の通信機器へ送出する。各データグラムには、受信側の通信機器のインターネット網におけるアドレス（IPアドレス）が付加されている。データグラムを受け取った場合、送信先（受信側）のIPアドレスに基づいて、通信機器は、近隣の通信機器のうち、受信側に近い方の通信機器へデータを送出する。これにより、コネクションを確立しなくても、送信側のデータは受信側へ届けられる。このようなコネクションレス型の通信システムでは、送信側および受信側の通信機器は、いずれも両者間の通信パスを把握していない。したがって、インターネット網の場合は、データ量（通信時間）に応じた料金体系、あるいは、1年毎など、所定の期間毎に一定の料金体系を採用していることが多い。両料金

体系は、送信側と受信側との距離に影響を受けないので、特に、海外との通信など、長距離の通信では、インターネット網を利用して通信することによって、通信費用を削減できる可能性が高い。

【0004】上記インターネット網は、従来は、電子メールなど、文字主体のデータ通信に使用されていたが、近年では、回線の帯域幅の向上に伴って、ビデオ会議システムやインターネット電話など、通信機器間でのリアルタイム双方向通信にも利用されている。

【0005】ところで、上記インターネット網に各通信機器を接続する方法は、専用線による接続と、ダイヤルアップ接続との2つに大別できる。専用線による接続方法は、通信機器と、インターネット接続業者（プロバイダ）との間に、専用の通信線を用意して、各通信機器とインターネット網とを常時接続する方法である。この場合、インターネット網に常時接続されているため、通信機器には固有のIPアドレスが割り当てられる。この方法は、大きな会社や大学などで採用されており、使用者は、通常、通信線の維持費用として、電話会社などに一定の費用を支払っている。

【0006】一方、ダイヤルアップ接続は、インターネット網に接続したいときに、通信機器とインターネット網とを接続する方法である。インターネット網への接続は、電話回線などを利用して、プロバイダと通信し、この通信をプロバイダが中継することによって行われる。プロバイダは、通信機器が接続されたとき、当該通信機器のIPアドレスとして、空いているIPアドレスを割り当てる。これにより、複数の通信機器間でIPアドレスを共用できる。また、この方法では、各通信機器との間に専用の通信回線も不要である。この結果、通信量が少ない場合には、専用線回線に比べて安価に利用できる。したがって、ダイヤルアップ接続方法は、小さな会社や個人宅など、通信量が比較的小さい場合に採用されることが多い。この場合、電子メールは、プロバイダが蓄積しており、使用者は、接続毎にプロバイダ内の所定の記憶領域を確認するなどして、電子メールの到着を確認する。

【0007】

【発明が解決しようとする課題】しかしながら、被呼側の通信機器がダイヤルアップ接続方法を採用していた場合、発呼側の通信機器は、被呼側がインターネット網に接続されているか否かを事前に判定できない。もし、発呼時において、被呼側の通信機器がインターネット網に接続されていれば、発呼側の通信機器は、被呼側と通信できるが、そうでない場合には、両通信機器は、通信できない。したがって、確実に接続されるとは限らず、即応性に欠けるという問題点を有している。この問題は、通常の電話と同様に通話しようとしている場合や、ビデオ会議システムの場合など、特に、リアルタイムで双方向通信しようとしている場合には致命的となる。

【0008】なお、この問題は、インターネット網に限らず、パソコン通信の場合など、各通信機器が必要に応じてネットワークに接続する場合であれば発生するが、以下に示すように、インターネット網へダイヤルアップ接続する場合には、さらなる問題点が発生する。

【0009】具体的には、インターネット網を構成する各通信機器、データグラムに含まれている送信先のIPアドレスに基づいて、当該データグラムを伝送する。したがって、通信するにあたって、送信側は、受信側のIPアドレスを把握している必要がある。ところが、ダイヤルアップ接続方法では、各通信機器のIPアドレスは、それぞれのプロバイダと接続するまで決定されない。したがって、送信側は、専用線接続方法のように、受信側のIPアドレスを予め把握しておくことができない。

【0010】そこで、従来は、この問題を解決するために、各通信機器間の通信を中継するために、固定のIPアドレスを持つサーバを設置している。この場合、各通信機器は、インターネット網に接続した後、上記サーバと通信を開始する。各通信機器が通信を開始すると、サーバは、一方との通信を他方へ中継する。この場合、サーバのIPアドレスへ送出したデータグラムが相手の通信機器へ転送されるので、各通信機器は、相手のIPアドレスを知る必要がない。この結果、ダイヤルアップ接続している通信機器間であっても、何ら支障なく通信できる。

【0011】ところが、サーバを設けた場合には、サーバを維持する必要があり、維持費用がかかるという問題が新たに発生する。また、サーバが混んでいた場合には、自通信機器と相手の通信機器とが空いていても通信できないという問題も派生する。さらに、サーバ内で通信相手を探す方法が確立されておらず、所望の通信相手を見つけることが困難である。例えば、現時点では、以下のような探索方法によって、相手を探すことが多い。すなわち、各通信機器は、サーバへ自らの名称を登録する。サーバは、受け取った名称のリストを表示し、各通信機器は、そのリスト内から所望の相手を選択する。この方法では、接続者数が増えるに従って、探索時の手間が増大する。

【0012】また、サーバを設置したとしても、相手の通信機器がネットワークに接続されていなければ、通信を開始できないという問題点は、依然として解決されていない。

【0013】本発明は、上記の問題点を鑑みてなされたものであり、その目的は、被呼側の通信機器がネットワークにダイヤルアップ接続されている場合に、当該通信機器の即応性を向上できる通信機器の呼び出し方法を提供することにある。

【0014】

【課題を解決するための手段】請求項1の発明に係るダ

ダイヤルアップ接続通信機器の呼び出し方法は、ネットワークへダイヤルアップ接続されるダイヤルアップ接続通信機器の呼び出し方法であって、上記課題を解決するために、以下の各工程を含んでいることを特徴としている。

【0015】すなわち、上記ネットワークとは別に設けられ、上記ダイヤルアップ接続通信機器を呼び出し可能な通信回線によって、発呼側の通信機器がダイヤルアップ接続通信機器へ接続要求を伝える第1工程と、接続要求を受けたダイヤルアップ接続通信機器が、上記ネットワークへダイヤルアップ接続する第2工程と、上記ネットワークを介して、発呼側の通信機器とダイヤルアップ接続通信機器とが通信する第3工程とを含んでいる。

【0016】なお、上記ネットワークとしては、例えば、インターネット網など、コネクショナル型のネットワークや、パソコン通信などが挙げられ、上記通信回線としては、例えば、電話回線や船舶無線などが挙げられる。

【0017】一般に、相手呼び出せないネットワークは、電話回線など、相手呼び出し可能な通信回線などに比べて実現が容易である。また、ダイヤルアップ接続のように、通信機器が必要に応じてネットワークに接続する場合には、ネットワークと通信機器との通信路と、例えば、アドレスなど、ネットワーク上の資源とを他の通信機器や他の用途と共用できる。したがって、ダイヤルアップ接続された通信機器は、上記通信回線を用いて直接通信する場合、および、ネットワークと専用線にて接続される場合に比べて、通信費用の低減が可能である。

【0018】上記構成では、発呼側の通信機器とダイヤルアップ接続通信機器との両通信機器が、ネットワークを介して通信する前に、発呼側の通信機器は、ダイヤルアップ接続通信機器へ接続要求を伝える。これにより、ダイヤルアップ接続通信機器がネットワークに接続されていない場合であっても、上記第3工程における通信時には、ネットワークへ接続させることができる。それゆえ、安い料金で通信可能なダイヤルアップ接続通信機器において、所望のタイミングで確実に通信を開始でき、リアルタイム通信が可能になる。

【0019】また、請求項2の発明に係るダイヤルアップ接続通信機器の呼び出し方法は、請求項1記載の発明の構成において、上記第3工程は、上記発呼側の通信機器およびダイヤルアップ接続通信機器のうちで送信側の通信機器が、当該第3工程にて送出するデータの少なくとも一部を暗号化して送出する暗号工程と、受信側の通信機器が、暗号化されたデータを復号する復号工程とを含んでいることを特徴としている。

【0020】なお、暗号化する場合に使用する方法は、暗号化と復号とで共通の暗号鍵を使用する方法や、公開鍵を用いて暗号化し、公開鍵とは別の秘密鍵を用いて復号

する方法など、種々の方法を適用できる。また、両通信機器は、第3工程に先立って、例えば、上記第1工程での通信、あるいは、郵送など、所定の方法により、共通の暗号鍵や相手の公開鍵などの暗号鍵を取得している。

【0021】ネットワークを介して通信する場合、伝送されるデータは、盗聴あるいは改ざんされる虞れがある。特に、ネットワークとして、インターネット網などを使用する場合には、発信側および受信側の通信機器がデータの伝送路を指定できないため、盗聴など、通信の妨害の危険性は大きい。

【0022】ところが、上記構成では、通信内容のうち、少なくとも一部は、暗号化によって、発呼側の通信機器およびダイヤルアップ接続通信機器以外の第三者から隠蔽されている。この結果、通信内容を暗号化せず、平文のまま伝送する場合に比べて、通信妨害に対する安全性を向上できる。

【0023】なお、暗号化するデータは、例えば、通信内容そのもの、両通信機器の使用者名あるいはアドレスなどが挙げられる。ただし、暗号化するデータ量が増大するに従って、両通信機器の負担が増大するので、通信の重要度を考慮して、一部のデータのみを暗号化してもよい。一般に、使用者名やアドレスなどが第三者に傍聴されると、通信内容の重要性を推測されやすい。したがって、画像や音声などの通信に先立って、使用者名やアドレスなどを送信する場合には、これらを暗号化することか特に望まれる。これにより、両通信機器の負担を余り増加させることなく、通信妨害に対する安全性を向上できる。

【0024】さらに、請求項3の発明に係るダイヤルアップ接続通信機器の呼び出し方法は、請求項2記載の発明の構成において、上記第1工程は、発呼側の通信機器あるいはダイヤルアップ接続通信機器が、暗号化の際に使用される暗号鍵を相手に通知する工程を含んでいることを特徴としている。

【0025】なお、暗号化の際に公開鍵を使用する場合、相手には、自らの秘密鍵に対応した公開鍵が通知される。また、共通の暗号鍵を用いて暗号化する場合、当該暗号鍵が相手に通知される。

【0026】上記構成では、接続要求毎に暗号鍵を通知するので、前回通信したときと暗号鍵を変更した場合であっても、何ら支障なく、両通信機器は、暗号化したデータを送受できる。加えて、通信回線を用いて、接続要求の通知と暗号鍵の送付との双方を一括して行っている。したがって、両者を個別に行う場合に比べて、通信回線を接続する手間を削減できる。

【0027】さらに、例えば、郵送などによって、暗号鍵を設定する場合、各通信機器は、使用前に暗号鍵を設定する必要がある。暗号鍵は、それぞれの通信機器毎に用意されるので、特に、通信相手の数が増加すると、設定時の手間も増大する。これに対して、請求項3記載の

発明の構成では、接続毎に暗号鍵を通知しており、各暗号鍵を予め設定する必要がないので、設定時の手間を削減できる。

【0028】また、暗号鍵は、通信回線を介して、相手の通信機器へ伝送され、当該暗号鍵にて暗号化されたデータは、ネットワークを介して伝送される。したがって、第三者が通信の妨害を試みる場合、双方の通信を傍受する必要がある。この結果、単一の通信手段にて、暗号鍵とデータとを送信する場合に比べて、通信妨害に対する安全性を向上できる。

【0029】一方、請求項4の発明に係るダイヤルアップ接続通信機器の呼び出し方法は、請求項1、2または3記載の発明の構成において、上記ネットワークには、発呼側の通信機器とダイヤルアップ接続通信機器との間の通信を中継するサーバが設けられており、上記第3工程は、上記両通信機器が、自らを示す登録名を上記サーバへそれぞれ通知する工程と、上記両通信機器が、相手の登録名を上記サーバへ通知して、相手の通信機器を選択する工程と、上記サーバが選択された通信機器間の通信を中継する工程とを含んでいることを特徴としている。

【0030】なお、上記ネットワークとしては、例えば、インターネット網など、コネクションレス型のネットワークが挙げられる。また、この構成では、上記請求項2あるいは3で暗号化する場合、特に適したデータとして、両通信機器の登録名が挙げられる。

【0031】上記構成では、請求項1と同様に、ダイヤルアップ接続通信機器がネットワークに接続されていない場合であっても、上記第3工程における通信時には、ネットワークへ接続させることができる。これにより、両通信機器は、ネットワークに設けられたサーバを介して、所望のタイミングで確実に通信を開始できる。なお、サーバが登録名を公開する場合であっても、使用者名を暗号化して登録することによって、両通信機器の使用人名を第三者から容易に隠蔽できる。

【0032】また、請求項5の発明に係るダイヤルアップ接続通信機器の呼び出し方法は、請求項1、2または3記載の発明の構成において、上記ネットワークは、例えば、インターネット網など、データを伝送する際、当該ネットワークにおけるアドレスによって送信先を特定すると共に、ダイヤルアップ接続通信機器に対して、接続毎に臨時のアドレスを割り当てるネットワークであり、上記第3工程は、ダイヤルアップ接続通信機器が、現接続における自らのアドレスを取得する工程と、電子メールによって、ダイヤルアップ接続通信機器が、発呼側の通信機器へ自らのアドレスを通知する工程と、発呼側の通信機器およびダイヤルアップ接続通信機器が、互いのアドレスにより相手特定して通信する工程とを含んでいることを特徴としている。

【0033】ところで、ダイヤルアップ接続通信機器の

場合には、ネットワークと接続するまでアドレスが未定である。したがって、従来の方法では、発信側の通信機器が受信側のアドレスを把握できず、ダイヤルアップ接続された通信機器同士は、ネットワークを介して通信できない。

【0034】一方、請求項4記載の発明の構成のように、両通信機器間の通信を中継するサーバをネットワークに設ける場合には、ダイヤルアップ接続された通信機器同士であっても、何ら支障なく通信できる。ところが、この場合には、サーバを別に設ける費用や維持費などが必要となる。また、サーバが混み合っている場合には、両通信機器間で通信できなくなる虞れがある。

【0035】これに対して、請求項5記載の発明の構成では、ダイヤルアップ接続通信機器は、ネットワークに接続した後、自らのアドレスが確定した時点で、発呼側の通信機器へ当該アドレスを通知できる。これにより、請求項4の構成のように、サーバを設けることなく、両通信機器は、ネットワークを介して通信できる。したがって、請求項4記載の発明の構成に比べて、通信に要する費用をさらに削減できると共に、サーバの混雑に関わらず、両通信機器は、確実に通信できる。

【0036】ところで、ネットワークを介する通信が終了すると、ダイヤルアップ接続通信機器は、ネットワークとの接続を切断する。ここで、ダイヤルアップ接続通信機器がネットワークとの回線切断に失敗すると、当該ダイヤルアップ接続通信機器は、ネットワークに接続され続けるので、通信費用が不所望に高騰する。特に、例えば、ダイヤルアップ接続通信機器が監視制御システムの子局である場合など、ダイヤルアップ接続通信機器の周囲に使用者がいない場合には、回線切断に失敗したことを把握しにくい。したがって、回線切断に失敗した場合、当該ダイヤルアップ接続通信機器が不所望にネットワークに接続される期間が長くなりがちであり、無駄な通信費用が増大する虞れが大きい。

【0037】これに対して、請求項6の発明に係るダイヤルアップ接続通信機器の呼び出し方法は、請求項1、2、3、4または5記載の発明の構成において、さらに、上記第3工程の後で、上記発呼側の通信機器がダイヤルアップ接続通信機器を上記通信回線にて直接呼び出して、当該ダイヤルアップ接続通信機器が当該通信回線との回線接続を正常に切断したか否かを確認する第4工程を含んでいることを特徴としている。

【0038】上記構成において、発呼側の通信機器は、ダイヤルアップ接続通信機器との通信が終了すると、例えば、直接呼び出した際の呼び出し音などによって、回線切断の成否を確認する。これにより、発呼側の通信機器は、ダイヤルアップ接続通信機器の回線切断失敗を確実に認識できる。したがって、例えば、発呼側の通信機器がダイヤルアップ接続通信機器へ回線切断を再度指示したり、発呼側の通信機器の使用人がダイヤルアップ接続

通信機器の設置場所へ赴いて回線を切断するなど、適切な処置を講じることができる。この結果、回線切断の失敗に起因する無駄な通信費用の発生を確実に防止できる。

【0039】なお、回線が接続されている期間と、回線が切断されている期間とで異なった呼び出し音を用いる通信回線の場合は、所定回数の呼び出し音があるまで着呼しないように、ダイヤルアップ接続通信機器を設定すると共に、確認時において、発呼側の通信機器が呼び出し音を当該所定回数までに識別することによって、回線の切断を確認できる。この場合、発呼側の通信機器が上記所定回数までに直接呼び出しに使用した回線を切断すれば、ダイヤルアップ接続通信機器がネットワークとの回線を正常に切断できた場合であっても通信費用は不要である。

【0040】ところで、請求項1の発明に係るダイヤルアップ接続通信機器の呼び出し方法を用いると、所望のタイミングで通信の開始が可能で、かつ、通信費用を削減できる通信システムを構築できる。

【0041】ここで、監視制御システムでは、一般に、子局が、親局から離れた場所に設置されており、かつ、親局が数多くの子局を監視制御する。したがって、親局と子局とが通信する際の費用は、増大しがちであり、通信費用の削減が強く要求されている。特に、設置場所を監視する場合など、子局が親局へ送出するデータが映像データの場合、データ量が極めて多いので、呼び出し可能な通信回線を介して当該データを伝送すると、高い通信費用が必要になる。一方、監視制御システムでは、指示の遅れが事故の拡大に直結するので、子局は、親局の指示に即座に回答しなければならぬ。したがって、ダイヤルアップ接続により接続されるネットワークのみを介して、子局が親局と通信する場合、子局が親局の指示に即応できず、事故を拡大させる虞れがある。これらの結果、監視制御システムでは、親局の指示に対する子局の即応性を保ったまま、通信費用を削減することが強く求められている。

【0042】これに対して、請求項7の発明に係る監視制御システムは、上記課題を解決するために、設備機器を有する子局と、当該子局との通信によって上記設備機器を制御する親局とを備えた監視制御システムにおいて、上記親局は、呼び出し可能な通信回線を介して上記子局を呼び出し、接続要求を伝えた後で、上記通信回線とは別に設けられたネットワーク経由で上記子局と通信する親局通信手段を備え、上記子局は、上記通信回線を介して、上記接続要求を受け取った後で、上記ネットワークにダイヤルアップ接続して、当該ネットワーク経由で上記親局と通信する子局通信手段を備えていることを特徴としている。

【0043】上記構成において、親局の親局通信手段は、例えば、使用者の指示があった時点などの任意の時

点で、電話などの通信回線を介して子局を呼び出す。一方、子局の子局通信手段は、親局からの接続要求を受け取った後、ダイヤルアップ接続によって、例えば、インターネットなどのネットワークとの接続を確立する。その後、親局と、子局とは、ネットワークを介してデータを送受する。

【0044】上記構成では、子局が、安い料金で通信可能なダイヤルアップ接続によって、ネットワークと接続されているので、通信回線のみを用いて、子局が親局と通信する場合に比べて、通信費用を大幅に削減できる。一方、呼び出し可能な通信回線を用いて、親局が子局を呼び出した後、ネットワークを介して、データの送受信が行われるので、親局は、所望のタイミングで子局との通信を開始できる。これらの結果、親局の指示に対して、子局が即応可能でありながら、子局と親局との間の通信費用を大幅に削減可能な監視制御システムを実現できる。

【0045】

【発明の実施の形態】

〔第1の実施形態〕本発明の一実施形態について図1ないし図4に基づいて説明すると以下の通りである。本実施形態に係るダイヤルアップ接続通信機器の呼び出し方法は、発呼側と被呼側とが電話回線およびインターネット網を介して通信でき、かつ、少なくとも被呼側の通信機器がインターネット網へダイヤルアップ接続されている通信システムに適用される呼び出し方法であって、例えば、日本とアメリカなどと、長距離で通信する際に特に好適な方法である。なお、ダイヤルアップ接続とは、通信機器がインターネット網などのネットワークと常時接続されておらず、各通信機器が必要と判断したときに、ネットワークと接続する方法である。

【0046】以下では、上記呼び出し方法、および、これを実施する通信機器について説明する前に、当該通信機器が使用される通信システムについて説明する。すなわち、図1に示すように、本実施形態に係る通信システム1は、上記呼び出し方法を具備し、発呼側あるいは被呼側となる通信機器2および3を備えている。本実施形態では、各通信機器2・3のいずれが発呼側になるか被呼側になるかは、特に決められておらず、両通信機器2・3は、後述するように、発呼側および被呼側双方の機能を有している。なお、被呼側となる通信機器2・3が、特許請求の範囲に記載のダイヤルアップ接続通信機器に対応する。

【0047】上記両通信機器2・3は、それぞれ電話回線（通信回線）4に接続されている。上記電話回線4は、例えば、ISDN（Integrated Services Digital Network）などのデジタル回線、あるいはアナログ回線などであり、各通信機器2・3は、例えば、ダイヤルを回すなどして、図示しない電話回線4の交換機へ相手先の電話番号を通知できる。これにより、各通信機器2・

3は、電話回線4を介して、互いに相手を呼び出し、直接通信できる。

【0048】また、各通信機器2・3の使用者は、インターネット接続業者（プロバイダ）5あるいは6に加入しており、通信機器2・3は、ダイヤルアップ接続によって、インターネット網（ネットワーク）7をそれぞれ使用できる。各通信機器2・3は、発呼側になる場合と被呼側になる場合とがあるので、両プロバイダ5・6には、同じ機能が要求される。以下では、説明の便宜上、通信機器2側のプロバイダ5について説明するが、プロバイダ6の構成も同様である。

【0049】具体的には、プロバイダ5は、電話回線4を介して通信機器2から接続要求を受けた場合、アカウント（使用資格）を示すIDと、各ID毎に予め設定されたパスワードとを入力させる。アカウントとパスワードとの照合が終わると、プロバイダ5は、自らが保有しているインターネット網7上におけるアドレス（IPアドレス）のうち空いているIPアドレスを、当該通信機器2の臨時のIPアドレスとして割り当てる。これにより、通信機器2は、現接続時における自らのIPアドレスを認識できる。この結果、通信機器2は、所定の大きさ毎に区切られたデータ列（データグラム）を作成してプロバイダ5へ送付したり、プロバイダ5から受け取ったデータグラムのうち、自分宛のデータグラムを識別できる。プロバイダ5は、通信機器2からのデータグラムをインターネット網7へ転送し、インターネット網7からのデータグラムを通信機器2へ送付する。これにより、通信機器2は、固有のIPアドレスを持たなくてもインターネット網7へ接続できる。

【0050】プロバイダ5は、ダイヤルアップ接続による加入者の間で、IPアドレスやインターネット網7との接続回線などを共有している。したがって、プロバイダ5において、ダイヤルアップ接続の接続料金は、通信機器2が固有のIPアドレスを保持し、専用の通信回線を介してインターネット網7と常時接続している場合、すなわち、専用回線接続の場合に比べて安く設定されていることが多い。

【0051】また、プロバイダ5は、電話回線4を介して通信機器2と通信するために、アクセスポイントを備えている。アクセスポイントは、例えば、市内局番で通話できる範囲内など、通信機器2の近隣に配されており、通信機器2は、プロバイダ5と通信する際、電話回線4の使用料（通話料）を安く抑えることができる。

【0052】さらに、プロバイダ5は、通信機器2のメールサーバでもある。具体的には、プロバイダ5は、通信機器2に、電子メールアドレスを予め割り当てており、これに対応した図示しない記憶領域（メールボックス）を備えている。通信機器2宛の電子メールは、プロバイダ5へ配達され、プロバイダ5は、通信機器2宛の電子メールを受け取って、対応するメールボックスに蓄

積する。プロバイダ5は、インターネット網7に常時接続されており、そのIPアドレスは、常に一定である。したがって、通信機器2がインターネット網7に接続されているか否か、および、接続時のIPアドレスに関わらず、電子メールは確実に配達される。各通信機器2は、ダイヤルアップ接続した際に、自分宛の電子メールを上記メールボックスから読み出すことができる。

【0053】現在、インターネット網は、広く普及しつつあり、多くのプロバイダがサービスを開始している。これらのプロバイダの多くは、ダイヤルアップ接続をサポートしており、メールサーバの機能を備えている。したがって、通信機器2および3を設けることによって、本実施形態に係る通信システム1を容易に構成できる。

【0054】続いて、各通信機器2・3の構成例として、例えば、ビデオ会議などのように音声と画像との双方を伝送する場合を中心に説明する。なお、以下では、音声と画像との双方を伝送する場合に限らず、両通信機器2・3が、インターネット網7などのネットワークを介して、リアルタイムにデータを伝送することをネットワーク会議と総称する。

【0055】また、各通信機器2・3の実現方法としては、後述するように種々の構成が考えられるが、ここでは、通信機器2（3）が、電話回線4およびインターネット網7との接続を制御する接続器2a（3a）と、入出力装置となるコンピュータ2b（3b）とを備えている構成について説明する。この構成では、本実施形態に係る呼び出し方法は、接続器2aが実施している。また、各通信機器2・3には、上記呼び出し方法による通信以外の通常通話用に、電話器2c・3cがそれぞれ設けられている。なお、両通信機器2・3は、同様の構成を有しているため、以下では、説明の便宜上、通信機器2の構成についてのみ詳細に説明する。

【0056】すなわち、コンピュータ2bは、例えば、ビデオカメラやマイクなど、図示しない入力装置を備えており、使用者側の音声や画像などをデジタルのデータ列として接続器2aへ伝送できる。また、コンピュータ2bは、モニターやスピーカーなどの出力装置（図示せず）を備えており、接続器2aを介し、通信機器3から受け取ったデータ列を画像や音声として使用者に通知できる。

【0057】コンピュータ2bと接続器2aの間は、例えば、RS232CやRS422A、IrDA、あるいは、LANなど、予め選択された通信方法によって接続されており、双方向にデータを送受できる。なお、両者間の通信方法は、リアルタイムに双方向通信が可能であれば、有線/無線、あるいは、デジタル/アナログ、通信速度や通信規格を問わない。

【0058】一方、本実施形態に係る接続器2aは、図2に示すように、本実施形態に係る呼び出し方法を実施するプログラムや各種設定などを記憶するFlashメ

メモリ11と、上記所定の通信方法でコンピュータ2bと通信するインターフェース部12と、電話回線4および電話器2cと接続されている通信用IC(Integrated Circuit)13と、接続器2a全体を制御するCPU(Central Processing Unit)14と、作業用の記憶領域となるRAM(Random Access Memory)15とを備えている。さらに、例えば、通信機器3の電子メールアドレスなど、接続器2aの状態を表示するために、状態表示液晶パネル16が設けられている。各部材11ないし16は、それぞれバス17に接続されており、各部材間のデータは、バス17を介して伝送される。

【0059】上記Flashメモリ11は、電氣的に書換え可能な不揮発性のメモリであって、後述する動作を行うプログラムと、当該プログラムにて使用する各種設定値とか格納されている。具体的には、通信機器3に関する設定値としては、直接呼び出す際の電話番号などが挙げられる。さらに、直接呼び出す際に、通信機器3が通信機器2を識別するためのパスワードも格納されている。当該パスワードは、予め通信機器3にも伝えられており、通信機器3は、このパスワードを照合することによって、正規の使用者からの呼び出しがどうかを判定できる。また、プロバイダ5に関する設定値として、プロバイダ5の電話番号、アカウント、パスワード、および自分の電子メールアドレスが格納されている。さらに、本実施形態では、インターネット網7を介して通信する際、通信機器2と通信機器3とは、例えば、RSA符号などの公開鍵暗号方式を用いて、通信内容の少なくとも1部を暗号化して通信する。したがって、Flashメモリ11は、暗号化および復号化の際に使用する秘密鍵および公開鍵も記憶している。なお、当然ながら、Flashメモリ11に代えて、ROM(Read-Only Memory)やバッテリーバックアップされたRAM、あるいは、ハードディスクなど、不揮発性を有する記録手段を用いてもよい。

【0060】また、インターフェース部12は、例えば、RS232Cインターフェースなど、コンピュータ2bと接続器2aとの通信方法に応じたインターフェースであり、CPU14は、当該インターフェース部12を介して、コンピュータ2bと通信できる。

【0061】さらに、上記通信用IC13は、例えば、モデム用のICなどであって、電話回線4の回線接続/切断を制御したり、CPU14が処理するデータ列と電話回線4を伝送される電気信号とを相互に変換したりできる。また、CPU14の指示に応じて、電話回線4と電話器2cとを接続して、電話器2cのベルを鳴らすこともできる。

【0062】一方、CPU14は、Flashメモリ11のプログラムに従って、インターフェース部12および通信用IC13を制御する。具体的には、接続器2aは、所望の電話番号をダイヤルして、電話回線4を介し

て、通信機器3と直接通信したり、プロバイダ5を介して、インターネット網7に接続したりできる。これにより、接続器2aは、後述するように、電話回線4を介した直接通信と、インターネット網7を介した通信とを所定の順番で行うことができる。

【0063】また、CPU14は、インターフェース部12あるいは通信用IC13を介して、コンピュータ2bや電話器2cを制御できる。これにより、接続器2aは、コンピュータ2bが、例えば、キー入力などによって、使用者からインターネット網7を介した接続を指示されたか否か、および、接続先などを判定できる。また、接続器2aは、電話回線4と電話器2cとを接続して、通常通話を行うことができる。

【0064】電話回線4を介して直接接続されている場合、CPU14は、通信用IC13を介して、通信機器3へ所定のメッセージを送出すると共に、通信機器3から受信したメッセージを識別できる。通信機器2・3間の通信方法は、例えば、V32、V32bis、V34、V21、あるいはV22などの規格に応じたシリアル通信であり、両者間でメッセージを送受できる。

【0065】一方、通信機器2とプロバイダ5とかダイヤルアップ接続されている場合、CPU14は、通信用IC13を介して、プロバイダ5とデータグラムを送受する。これにより、接続器2aは、現接続時のIPアドレスを認識すると共に、所定の形式の電子メールを送出できる。さらに、接続器2aは、プロバイダ5に設けられた自分のメールボックスを所定の周期で確認して、通信機器3からの電子メールが到着しているか否かを判定する。電子メールが到着していた場合は、電子メールの内容を確認して、相手のIPアドレスを認識できる。

【0066】加えて、インターネット網7を介して接続している場合、CPU14は、インターフェース部12および通信用IC13を制御して、コンピュータ2bとインターネット網7との間の通信を中継する。なお、コンピュータ2bと接続器2aとの間において、例えば、音声データ列や画像データ列そのものなど、インターネット網7にて伝送されるデータグラムと異なる形式でデータが伝送されている場合、CPU14が両者を相互変換する。一方、コンピュータ2bとの間でデータグラムが伝送される場合は、CPU14は、当該データグラムをそのまま通過させる。これにより、接続器2aは、コンピュータ2bとインターネット網7との間で、何ら支障なく通信を中継できる。

【0067】また、CPU14は、通信機器3の公開鍵を用いて、通信機器3へ送出するデータを暗号化したり、予め記憶されている自らの秘密鍵を用いて、通信機器3から受け取ったデータを復号したりできる。

【0068】なお、上記の説明では、通信機器2において、コンピュータ2bが入出力を担当しているが、入出力装置は、これに限るものではない。上述したように、

コンピュータ2 bなどの入出力装置と接続器2 aとの間のデータの伝送方法は、無線/有線、アナログ/デジタル、あるいは通信速度や通信規格などを問わない。したがって、電話器やビデオカメラなど、種々の入力装置を使用できる。ただし、この場合には、接続器2 aは、インターネット網7で伝送されるデータグラムと、電話器2 cおよび接続器2 a間のデータとを、相互に変換する必要がある。

【0069】特に、図3に示すように、通信機器22の入力装置として、電話器22 cを使用する場合には、インターネット網7を介した通話と通常の通話との双方で電話器22 cを使用できる。また、従来と同様の構成の電話器22 cと、電話回線4との間に、接続器22 aを接続するだけでよいので、他の入力装置を設ける場合に比べて設置が容易になる。

【0070】この場合は、入力装置が電話器22 cのみなので、インターネット網7を介した通話と、通常の通話とを区別する必要がある。これは、接続器22 aにスイッチなどを設けて、インターネット網7を介した通話を指示してもよいが、例えば、以下に示す方法を用いることによって、使用者は、電話器22 cのみを用いて両者を区別できる。すなわち、使用者は、受話器を取った後、“#” ボタンを3回押すなど、通常の通話では使用しない操作をした後、予め設定された相手の登録番号のボタンを押す。接続器22 aは、電話器22 cから送られてくる音声信号によって、これらのボタン操作を認識し、接続要求の発生と、相手先とを識別する。そして、インターネット網7を介して、相手と通話が可能になると、例えば、電話器22 cのベルを鳴らすなどして、使用者に通知する。一方、通常の電話番号が押されると、接続器22 aは、電話器22 cからの信号によって、通常の通話と判定し、電話回線4へ当該信号をそのまま通過させる。これにより、電話器22 cは、接続器22 aがない場合と同様に、電話回線4を介して直接通話できる。このように、インターネット網7を介した通信を指示する操作として、入力装置で、通常使用しない操作を割り当てることによって、従来と同様の入力装置のみを用いて、インターネット網7を介した接続要求と、通常の通信接続要求と区別できる。

【0071】また、上記の説明では、通信機器2において、コンピュータ2 bが入出力を担当し、例えば、電話回線4あるいはインターネット網7と接続する順番の制御や、暗号化などを接続器2 aが担当しているが、両部材2 a・2 bの役割分担も、これに限るものではない。例えば、上記接続の順番制御や暗号化など、接続器2 aの処理の殆どを、コンピュータ2 bが行ってもよい。この場合は、接続器2 aは、通常のモデムやISDNのターミナルアダプタなどを流用できる。

【0072】なお、図1および図3では、説明の便宜上、接続器2 a (22 a)、コンピュータ2 b、および

電話器2 c (22 c) をそれぞれ別の部材として記載しているが、当然ながら一体化してもよい。一体化の例としては、図1に示す接続器2 aとコンピュータ2 bとが一体となった家庭用テレビ、あるいは、図3に示す接続器22 aと電話器22 cとを一体に形成した電話器などが挙げられる。さらに、電話回線4として、無線の電話回線を使用すると、上記一体型の電話器を携帯電話として構成することもできる。また、入出力装置としてビデオカメラを採用し、接続器2 aと一体化すると、インターネット網7を介して、画像や音声などを送出できるビデオカメラが実現できる。この場合、無線電話回線を使用すると、携帯できるので、さらに好適である。一体/別体、あるいは、入出力装置、さらには、電話回線4が無線/有線などを組み合わせると、通信機器2は、種々の構成が考えられる。

【0073】次に、図1に示す通信システム1において、通信機器2が通信機器3を呼び出す場合の動作を、図4に示すフローチャートに基づき、各ステップ毎に説明すると以下の通りである。

【0074】すなわち、通信機器2の使用者が、例えば、コンピュータ2 bのキー入力などによって、通信機器3との通信を通信機器2へ指示すると、ステップS1 aにおいて、通信機器2は、通信機器3の電話番号をダイヤルする。これにより、通信機器3は、電話回線4を介して呼び出される。なお、以下では、ステップS1 aを単にS1 aのように略称する。また、通信機器2が行う処理には、S1 aのように末尾にaを示し、通信機器3が行う処理には、S1 bのように末尾にbを付加して、両者を区別する。

【0075】一方、通信してもよい場合、通信機器3の使用者は、例えば、予めボタンを押すなどして、受信ウエイトのオンを通信機器3へ指示している (S1 b)。通信機器3は、受信ウエイトがオンの場合、電話の呼び出しに応答する (S2 b)。この結果、通信機器2と通信機器3とは、電話回線4を介して直接通信を開始できる。

【0076】通信機器2は、通信機器3の応答を検出すると、例えば、“CALL CU—SEEME from 通信機器2の使用者名 PASSWORD:パスワード通信機器2の使用者の電子メールアドレス 通信機器2の公開鍵” など、所定のメッセージを送出して、通信機器2の使用者名、パスワード、電子メールアドレス、および通信時に使用する通信機器2の公開鍵を通信機器3に通知する (S2 a)。通信機器3は、受け取った使用者名とパスワードとの組み合わせを予め記憶している組み合わせと照合して、正規の通信相手か否かを判定する (S3 b)。使用者名やパスワードが誤っている場合や、相手が音声によって通話している場合など、正規の通信相手では無い場合、通信機器3の接続器3 aは、電話器3 cのベルを鳴らして、電話回線4と電話器

3cとを接続する(S4b)。これにより、通信機器3の使用者は、電話器3cを用いて相手と話すことができる。この場合は、以降の処理は行われない。

【0077】一方、上記S3bにおいて、正規の通信相手であることが確認できると、通信機器3は、例えば、"OK CU-SEEME from 通信機器3の使用者名 通信機器3の使用者の電子メールアドレス 通信機器3の公開鍵"など、所定のメッセージを送出し(S5b)、通信機器2は、当該メッセージを受け取る(S3a)。これにより、通信機器2は、自らの接続要求を通信機器3が受け取ったこと、通信機器3の使用者名、電子メールアドレス、および、通信時に使用する通信機器3の公開鍵を取得できる。

【0078】その後、通信機器2および3は、それぞれ電話回線4との接続を切り(S4a・S6b)、所定のプロバイダ5あるいは6へダイヤルアップ接続を開始する(S5a・S7b)。また、各通信機器2・3において、接続器2a・3aは、コンピュータ2bへ指示して、例えば、コーレル大学が開発したCU-SEEMEなど、コンピュータ2bに予め用意されているネットワーク会議ソフトを起動させる(S6a・S8b)。

【0079】上記S5aおよびS7bにおいて、ダイヤルアップ接続に成功すると、各通信機器2・3は、それぞれのプロバイダ5・6から、現接続限りのIPアドレスを取得する(S7a・S9b)。この結果、各通信機器2・3は、インターネット網7へデータグラムを送出できるようになる。

【0080】ただし、現時点では、通信機器2および通信機器3は、相手のIPアドレスを把握しておらず、相手宛のデータグラムを生成できない。したがって、各通信機器2・3は、プロバイダ5・6など、所定のIPアドレスを有する機器とは通信できるが、両通信機器2・3間の通信を開始できない。

【0081】続いて、各通信機器2・3は、上記S2aあるいはS5bにて相手から送られてきた公開鍵を用いて、自らの名前と自らのIPアドレスとを暗号化する。その後、各通信機器2・3は、当該暗号文を電子メールとして、相手先の電子メールアドレスへ送出する(S8a・S10b)。各電子メールは、相手先の公開鍵で暗号化されており、相手が保持している秘密鍵を用いないと復号できない。

【0082】また、各通信機器2・3は、例えば、5秒間隔など、所定の周期で、プロバイダ5・6に設けられた自分のメールボックスを監視している。相手からの電子メールが到着すると、各通信機器2・3は、上記メールボックスから当該電子メールを読み出して、自らの秘密鍵を用いて暗号を解読する。これにより、各通信機器2・3は、相手の名前とIPアドレスとを取得できる(S9a・S11b)。

【0083】さらに、各通信機器2・3は、相手のIP

アドレスを取得すると、ネットワーク会議ソフトへ当該IPアドレスを通知し、相手呼び出す。これにより、ネットワーク会議ソフトにて通信が開始される(S10a・S12b)。

【0084】ところで、各データグラムには、送信先のIPアドレスの他にも、送信側のIPアドレスが含まれている。これにより、一方の通信機器2(3)が相手の通信機器3(2)を呼び出した場合、被呼側の上記ネットワーク会議ソフトは、受信したデータグラムに基づいて、発呼側のIPアドレスを認識できる。したがって、一方が呼び出した時点で通信を開始できる。具体的には、上記S10aの処理がS12bの処理よりも早く開始された場合には、通信機器3は、上記S11bを行う必要がない。同様に、上記S12bの方が早い場合には、通信機器2は、上記S9aの処理を省略できる。なお、上記ネットワーク会議ソフトは、双方が同時に呼び出した場合でも通信できるように作成されているので、上記各処理S9a・S11bを省略しない場合であっても、何ら支障なく通信を開始できる。

【0085】さらに、一方の通信機器2(3)が相手の通信機器3(2)を呼び出した時点で、通信を開始できるので、両方の通信機器2・3がダイヤルアップ接続している場合には、いずれか一方は、電子メールを発信しなくても、両通信機器2・3は、通信を開始できる。ただし、両通信機器2・3が電子メールを発信した場合は、いずれか一方の電子メールが到着した時点で通信を開始できるので、一方のみが電子メールを発信する場合に比べて、通信開始をより早く開始できる確率が高くなる。

【0086】会議中は、コンピュータ2bからの音声および画像は、接続器2a、プロバイダ5、インターネット網7、プロバイダ6、および接続器3aを介して、コンピュータ3bへ送られており、コンピュータ3bからの音声および画像は、上記経路を逆方向に送られている。これにより、通信機器2と通信機器3との使用者は、ネットワーク会議ソフトにより通信できる(S10a・S12b)。会議が終了すると、各通信機器2・3は、それぞれダイヤルアップ接続を切断し(S11a・S13b)、通信機器2・3間の通信が終了する。

【0087】また、例えば、受信側の使用者が不在の場合や、インターネット網7を介した通信を受けたくない場合には、例えば、所定のボタンを押すなどして、接続器3aへ通信ウェイトのオフを指示している。この場合は、接続器3aは、上記S2以降の処理を行わず、電話器3cへ無条件に接続する。

【0088】ところで、インターネット網7を介して通信する場合、各通信機器2・3が送出したデータグラムは、送出時点において、どのような経路を辿って宛先に到達するか不明であり、インターネット網7を構成する機器は、データグラムを受け取った時点で、次にデー

タグラムが通過する機器を決定する。

【0089】したがって、各データグラムが通過した機器において、データグラムの改変や複写などが容易であり、電話回線4を介して直接通信する場合に比べて通信を妨害しやすい。特に、使用者名とIPアドレスとを電子メールにて平文のまま送出した場合は、使用者名から通信の重要性を判断しやすいため、以後の通信が重点的に妨害される可能性が高くなる。一方、暗号処理や復号処理は、演算処理が不可欠であるので、暗号化しない場合と比較すると、各通信機器2・3には、高い処理能力が要求される。

【0090】したがって、本実施形態では、通信時の負担と、妨害に対する安全性とを両立するために、電子メールの内容のみを暗号化している。ただし、妨害に対して、さらに高い安全性が要求される場合には、ネットワーク通信ソフトの通信期間も通信内容を暗号化することによって、比較的容易に安全性を向上できる。

【0091】また、各データグラムが通過する経路が決まっていないため、データグラムの到着時刻の保証が困難である。また、ある通信路において、データ量が許容範囲を越えると、データグラムが失われる虞れがある。ただし、本実施形態に係る通信システム1では、音声データや画像データを伝送するために、各通信機器2・3は、インターネット網7と十分な通信容量を有する通信回線を介して接続している。また、両プロバイダ5・6を選択する際、両プロバイダ5・6間が十分な通信容量を有する回線で接続されているようなプロバイダを選択している。したがって、電子メールのように、音声データや画像データに比べてデータ量が極めて少ない場合には、遅延や損失の危険性は、実用上十分に低い値になっている。なお、所定の時間内に電子メールが到着しない場合に電子メールを再送すれば、遅延や損失の可能性をさらに低減できる。

【0092】なお、本実施形態では、両通信機器2・3は、インターネット網7での通信に先立って、電話回線4にて互いの電子メールアドレスを交換しているが、これに限るものではない。例えば、図2に示すFlashメモリ11などに相手の電子メールアドレスを予め記憶しておいてもよい。ただし、電子メールアドレスは、使用者の都合によって、変更する場合がある。この場合、各通信機器2・3の使用者は、電子メールアドレスを変更する度に、相手に新しい電子メールアドレスを通知すると共に、相手の通信機器2・3の使用者は、受け取った電子メールアドレスを、それぞれの通信機器2・3へ設定しなおす手間が生じる。これに対して、本実施形態では、発呼毎に、互いの電子メールアドレスを通知しているので、電子メールアドレス変更時の手間を大幅に削減できる。

【0093】〔第2の実施形態〕上記第1の実施形態は、電話回線4とは別の通信手段として、インターネッ

ト網7を使用し、通信機器2と通信機器3とがインターネット網7により直接通信するものである。これに対して、図5に示すように、本実施形態に係る通信システム31は、電話回線34とは別の通信回線として、インターネット網37を使用する点では、第1の実施形態と同様である。ただし、通信機器32と通信機器33とが、インターネット網37上に設けられたサーバ38を介して通信する点か異なっている。なお、通信システム31では、通信機器32ないしインターネット網37の各部件は、図1に示す通信機器2ないしインターネット網7と略同様の機能を有している。したがって、異なっている部分のみ説明し、同様の部分の説明は省略する。

【0094】本実施形態に係る通信システム31に設けられたサーバ38は、リフレクタなどと呼ばれており、固有のIPアドレスを有し、サーバ38と通信している通信機器32・33間の通信を中継できる。具体的には、サーバ38には、現在通信している機器のIPアドレスと登録名との組み合わせを格納する領域が設けられている。各機器がサーバ38へ登録名を通知すると、サーバ38は、当該機器のIPアドレスと登録名との組み合わせを上記領域に格納する。また、サーバ38は、各機器の要求に応じて、上記領域から登録名のリストを送出できる。これにより、各機器は、サーバ38を介して、現在通信可能な機器の登録名を知ることができる。さらに、機器は、サーバ38へ登録名を指定して、所望の通信相手を選択できる。

【0095】サーバ38は、機器の登録名を格納した時点で、全機器のIPアドレスと登録名と記憶している。したがって、サーバ38は、機器が通信相手を指定した場合、一方から受け取ったデータグラムを他方のIPアドレスへ送出できる。なお、サーバ38は、ある機器から受け取ったデータグラムを複数の機器へと転送できる。この場合は、複数の機器間での通信が可能になる。

【0096】現在、インターネット網37上には、種々のサーバ38が設けられており、その中には、不特定多数の機器で使用できるように、IPアドレスを公開しているサーバ38も存在している。したがって、これらのサーバ38を選択することによって、上記通信システム31を容易に構成できる。

【0097】本実施形態では、各通信機器32・33のハードウェア構成は、図1に示す通信機器2・3と同様であり、搭載されているソフトウェアの相違によって、動作が異なっている。したがって、以降では、通信機器32か通信機器33を呼び出す際の動作について説明し、ハードウェア構成については説明を省略する。

【0098】図6のフローチャートに示すように、本実施形態に係る呼び出し方法は、図4に示すステップS1aないしS11aおよびS1bないしS13bと同様の処理を行うステップ(S21aないしS31a、およびS21bないしS33b)を備えている。

【0099】ただし、第1の実施形態において各通信機器32・33が通信相手特定の際に、電子メールを用いて、互いのIPアドレスを交換していたのに対して、本実施形態では、各通信機器32・33は、サーバ38へ所定の登録名を登録し、相手の登録名を選択して、通信相手特定している。したがって、図4に示すS8a・S9a、およびS10b・S11bのように、自らのIPアドレスを互いに交換するステップに代えて、以下に示す各ステップ、S28a・S29a、およびS30b・S31bが設けられている。また、S22aおよびS25bにおいて、各通信機器32・33は、電子メールアドレスの通知を省略している。

【0100】すなわち、S27aおよびS29bの処理を終了した時点において、各通信機器32・33は、それぞれのプロバイダ35・36を介して、インターネット網37へ、自らのIPアドレスを含むデータグラムを送出できる。また、この時点では、S22aあるいはS25bで相手が送出した公開鍵および使用者名を取得している。

【0101】各通信機器32・33は、それぞれの使用者名を上記公開鍵によって暗号化する。さらに、各通信機器32・33は、暗号化された使用者名を登録名として、サーバ38へ通知する。サーバ38は、各通信機器32・33の登録名とIPアドレスとの組み合わせを登録する(S28a・S30b)。サーバ38は、各通信機器32・33が登録名の通知時に送出したデータグラムなどに基づいて、それぞれのIPアドレスを取得できる。

【0102】本実施形態では、各通信機器32・33の登録名は、暗号化されてサーバ38に登録されている。したがって、サーバ38と通信している第三者は、登録名のリストを見ることができると、使用者名を知ることができない。この結果、第1の実施形態にて電子メールを暗号化した場合と同様に、本実施形態においても、使用者名を第三者から隠蔽できる。

【0103】次に、各通信機器32・33は、サーバ38へ登録名のリストを要求する。さらに、各通信機器32・33は、リスト中の各登録名を、自分の秘密鍵を用いて復号して、予め通知されている使用者名と復号結果とが一致する登録名を選択する。その後、各通信機器32・33は、通信相手として、当該登録名をサーバ38へ通知する(S29a・S31b)。サーバ38は、通知の際に使用されるデータグラムなどから一方のIPアドレスを取得し、登録名に対応するIPアドレスから他方のIPアドレスを取得する。その後、サーバ38は、上記両IPアドレスの一方からデータグラムを受け取ると、他方のIPアドレスへデータグラムを転送する。これにより、各通信機器32・33は、互いのIPアドレスを知らなくても、互いに双方向に通信できる。本実施形態では、上述の第1の実施形態と同様に、ネットワー

ク会議ソフトによる通信中、各通信機器32・33は、通信内容を暗号化せず、通信時の負担を低減している。しかしながら、相手の公開鍵を用いて、当該期間中も通信内容を暗号化することによって、通信妨害に対する安全性をさらに向上できる。

【0104】S29a・S31b以降は、第1の実施形態と同様に、両通信機器32・33は、ネットワーク会議ソフトを用いて双方向通信した後、会議の終了と共にダイヤルアップ接続を切断して、通信が終了する。

【0105】本実施形態に係る通信システム31では、サーバ38が通信を中継しているので、通信機器32が通信機器33を呼び出す際、互いのIPアドレスを必要としない。したがって、両プロバイダ35・36は、それぞれの通信機器32・33の電子メールアドレスでなくてもよく、通信機器32・33は、電子メールを送受できなくてもよい。この場合でも、本実施形態と同様の効果が得られる。

【0106】各通信機器32・33は、上記S28a・S30bにおいて、サーバ38のIPアドレスへ登録名を通知する必要がある。このIPアドレスは、例えば、図2に示すFlashメモリ11などに予め記憶していてもよいし、電話回線34での通信中に打合せてもよい。上記S28a・S30bでの登録前に、通信機器32・33間で、共通のサーバ38が指定されていれば、サーバ38の指定方法は問わない。

【0107】〔第3の実施形態〕上記第1および第2の実施形態は、電話回線4・34による直接通信とは別の通信手段として、インターネット網7・37を使用している。これに対して、本実施形態では、別の通信手段として、パソコン通信を利用する場合について説明する。

【0108】図7に示すように、本実施形態に係る通信システム41において、各通信機器42・43の使用者は、パソコン通信に加入しており、通信機器42・43は、近隣のアクセスポイント45・46まで電話し、パソコン通信サーバ47にダイヤルアップ接続できる。

【0109】パソコン通信サーバ47は、通信機器42・43と通信して、例えば、データベース検索など、所定のサービスを提供している。さらに、本実施形態に係るパソコン通信サーバ47は、図5に示すサーバ38と同様に、両通信機器42・43間の通信を中継できる。これにより、両通信機器42・43間は、パソコン通信サーバ47を介して、双方向に通信できる。

【0110】パソコン通信サーバ47は、図1に示すプロバイダ5・6と同様に、加入者をIDなどによって管理しており、各通信機器42・43が電話回線44を介して接続した場合に、IDおよびパスワードを照合して、それぞれの通信機器42・43を識別する。ただし、図1に示す通信システム1のように、インターネット網7を介して通信する場合とは異なり、図7に示す通信システム41では、両通信機器42・43のIDが、

いずれもパソコン通信サーバ47により管理されている。したがって、当該通信システム41では、それぞれのIDによって通信相手を選定する。なお、各アクセスポイント45・46とパソコン通信サーバ47との間は、専用の回線48・48で互いに接続されている。

【0111】現在、上記パソコン通信サーバ47は、数多く設けられている。したがって、その中の一つを選択し、通信機器42・43を設けることによって、比較的容易に通信システム41を構成できる。

【0112】本実施形態に係る通信機器42・43は、第1の実施形態に示す通信機器2・3(22)と略同様のハードウェア構成である。ただし、本実施形態に係る通信機器42・43は、パソコン通信サーバ47に接続されている場合、当該パソコン通信サーバ47との通信方式に応じた形式のデータを送受する。なお、当該形式のデータの送受は、通信機器2・3のハードウェアあるいはソフトウェアを一部変更するだけで容易に実現できる。

【0113】上記構成において、通信機器42が通信機器43を呼び出す際、通信システム41は、図8に示すように動作する。すなわち、S41aないしS44a、および、S41bないしS46bにおいて、通信機器42は、パソコン通信サーバ47を介して通信する前に、図6と同様の処理を行い、電話回線44を介して通信機器43を呼び出して接続要求を伝える。この際、両通信機器42・43は、互いの公開鍵を交換する。

【0114】続いて、S45aないしS48a、およびS47bないしS50bにおいて、図6と同様に、両通信機器42・43は、それぞれパソコン通信サーバ47へダイヤルアップ接続して、ネットワーク会議ソフトを介して通信する。

【0115】ただし、本実施形態では、各通信機器42・43に固有のIDを用いて通信相手を選定する。したがって、図6に示すS27a～S29a、および、S29b～S31bの処理は、省かれている。また、本実施形態では、S47aおよびS49bにおいて、ネットワーク会議ソフトで通信する際、両通信機器42・43は、電話回線44を介して、予め交換した相手の公開鍵を用いて、通信内容をそれぞれ暗号化して送出する。また、暗号化された通信内容は、予め保持している自らの秘密鍵を用いて復号する。これにより、通信内容を第三者から隠蔽できる。

【0116】〔第4の実施形態〕上記第1ないし第3の実施形態では、通信機器2(32・42)が通信機器3(33・43)を呼び出すときであっても、これとは逆に、通信機器3(33・43)が通信機器2(32・42)を呼び出すときであっても、本発明に係るダイヤルアップ接続通信機器の呼び出し方法が使用される構成について説明している。しかしながら、本発明に係るダイヤルアップ接続通信機器の呼び出し方法は、一方の通信

機器が他方の通信機器を呼び出すときのみにも使用してもよい。

【0117】以下では、監視カメラシステム(監視制御システム)を例にして、親局側が子局側を呼び出す際のみ、本発明に係るダイヤルアップ接続通信機器の呼び出し方法を使用する場合について詳細に説明する。なお、ネットワークとしては、第1ないし第3の実施形態に示すように、インターネット網やパソコン通信などを利用できるが、以下では、第1の実施形態と同様に、インターネット網を用いた場合を例にして説明する。

【0118】すなわち、本実施形態に係る監視カメラシステム51は、例えば、無人駐車場の監視などに用いられるものであって、図9に示すように、本社に配された親局(発呼側の通信機器)52と、各駐車場に配された子局(ダイヤルアップ接続通信機器)53とを備えている。当該子局53には、監視カメラ53bが取得した映像を親局52へ送出する送信装置(子局通信手段)53aが設けられており、各監視カメラ53bが取得した映像は、子局53の送信装置53aを介して、親局52の受信装置(親局通信手段)52aへ送られる。親局52では、当該映像に基づいて、無断駐車の有無が確認される。これにより、本社1か所のみで、全国の無人駐車場を監視できる。したがって、各駐車場に監視のための人材を派遣する必要がなく、人件費を削減できる。なお、料金回収は、例えば、週1回、地元の契約社員などによって回収される。

【0119】より詳細には、上記子局53の送信装置53aは、図1に示す接続器3aと略同様の構成である。ただし、複数の監視カメラ53bを制御するために、監視カメラ53bの数に応じた数のインターフェースを備えている点が異なっている。また、これに伴って、親局52からの指示を認識して、映像の取得が指示された監視カメラ53bを選択し、当該監視カメラ53bに映像の取得を指示する機能が付されている。ただし、当該機能は、例えば、図2に示すCPU14が所定のプログラムを実行することによって実現できるため、上記接続器3aと同様のハードウェアによって、送信装置53aを実現できる。

【0120】また、上記各監視カメラ53bは、駐車場の各駐車スペースに駐車した車両のナンバープレート撮影可能な位置に配されている。また、各監視カメラ53bが取得可能な映像の解像度は、ナンバープレートの文字を読み取り可能な程度に設定されている。各監視カメラ53bおよび上記送信装置53aは、例えば、図1に示すコンピュータ2bおよび接続器2aのように、所定の通信方法によって接続されており、監視カメラ53bは、送信装置53aの指示に応じて映像を取得できると共に、取得した映像を示す映像データを送信装置53aへ送出できる。

【0121】さらに、本実施形態では、電話回線54の

一部に無線電話システムが使用されており、送信装置53aは、携帯電話器53cを介して、親局52あるいはプロバイダ56と接続される。無線電話システムは、例えば、パーソナル・ハンディホン・システム（以下では、PHSと称する）や自動車電話システムなど、種々のシステムが利用可能であり、子局53には、各システムに応じた携帯電話器53cが設けられる。なお、図1に示す接続器3aと同様に、無線電話システムを利用せずに、送信装置53aと電話回線54とを直接接続してもよい。

【0122】これにより、子局53は、図1に示す通信機器33と同様に、電話回線54を介して親局52と直接通信できると共に、電話回線54およびプロバイダ56を介して、インターネット網57へダイヤルアップ接続できる。

【0123】一方、上記親局52は、図1に示す通信機器2と同様に、電話回線54を介する直接接続と、インターネット網57を介する接続との双方によって、子局53と通信可能である。ただし、本実施形態に係る親局52は、上記通信機器2とは異なり、専用線58にて、インターネット網57と直接接続されている。これにより、親局52は、本発明に係るダイヤルアップ接続通信機器の呼び出し方法を用いて、子局53を呼び出して通信できる。なお、本実施形態に係る親局52が専用線58にてインターネット網57に常時接続されているので、親局52には、固有のIPアドレスが割り当てられている。

【0124】具体的には、本実施形態に係る親局52は、図1に示す接続器2aに代えて、受信装置52aが設けられており、コンピュータ2b・電話器2cに代えて、監視カメラ53bからの映像を使用者に報知すると共に、使用者の指示を受け取る端末52bが設けられている。受信装置52aおよび当該端末52bは、上記接続器2aおよびコンピュータ2bと同様に、例えば、LANなど、所定の通信方法によって接続されており、双方向にデータを送受できる。

【0125】本実施形態に係る受信装置52aは、ターミナルアダプタ(TA)機能を具備するものであって、図示しないデジタル回線終端装置(DSU)を介して、ISDN回線と接続可能に構成されている。ISDN回線は、単一の加入者契約で、2つの回線(Bチャンネル)を同時使用可能なデジタル回線であり、一方の回線が、専用線58としてインターネットに接続するために専有されており、他方が電話回線54として使用される。なお、専用線58は、これに限らず、ケーブルテレビ回線や、光ファイバなど、種々の回線を使用できる。ただし、ISDN回線を使用すると、単一の加入者契約によって、専用線58と電話回線54との双方を実現できるので、比較的安価に親局52を実現できる。

【0126】具体的には、図10に示すように、受信装

置52aは、図2に示す接続器2aと類似した構成であるが、通信用IC13に代えて、上記DSUに接続されるS/T点インターフェース(S/T点I/Fと略称する)18が設けられている。当該S/T点I/F18は、CPU14の指示に基づいて、呼の設定/切断(回線接続/切断)を制御したり、CPU14が処理するデータ列と、ISDN回線を伝送される電気信号とを相互に変換できる。また、S/T点I/F18は、CPU14が処理するデータ列を音声信号に変調した後で、ISDN回線に送出し、ISDN回線から送られてきた音声信号を復調して、CPU14が処理するデータ列に変換することもできる。これにより、受信装置52aは、子局53の送信装置53aと電話回線54を介して直接通信できる。受信装置52aと送信装置53aとの間の通信方法は、例えば、V32、V32bis、V34、V21、あるいはV22など、所定の規格に応じたシリアル通信であり、両者間でメッセージを送受できる。

【0127】これにより、受信装置52aは、電話回線54を介して子局53を直接呼び出しできると共に、専用線58およびインターネット網57を介して、子局53と通信できる。

【0128】なお、親局52全体としての機能が同じであれば、用途に応じて、受信装置52aと端末52bとの役割分担や、両者が一体に形成されているか否かなどを自由に設定できるが、以下では、受信装置52aが監視カメラ53bからの映像を受け取るサーバとして働く場合を例にして説明する。この場合は、各監視カメラ53bからの映像は、受信装置52aに蓄積され、端末52bは、受信装置52aに指示して、これらの映像を受け取り、当該映像を表示する。一方、使用者が、ある監視カメラ53bが配置されている場所の映像を取得したいと判断した場合、端末52bは、例えば、キー入力などによって、使用者の指示を識別し、当該監視カメラ53bに対する映像の取得要求があったことを受信装置52aへ通知する。受信装置52aは、端末52bからの通知に基づいて、監視カメラ53bに対応する子局53を識別し、本発明に係るダイヤルアップ接続通信機器の呼び出し方法を用いて当該子局53を呼び出す。

【0129】以下では、子局53を呼び出す際における親局52および子局53の動作について、図11に示すフローチャートに基づき説明する。なお、上記第1ないし第3の実施形態に係るフローチャートと同様に、発呼側、すなわち、親局52の動作を示すステップは、例えば、S61aなど、末尾に“a”を付した符号にて参照し、被呼側、すなわち、子局53の動作を示すステップは、末尾に“b”を付した符号にて参照する。

【0130】すなわち、親局52において、端末52bは、例えば、使用者の指示などに応じて、監視カメラ53bからの映像を取得したいことを示す受信要求を生成

し、受信装置52aに通知する(S61a)。受信装置52aは、当該受信要求に基づいて、当該監視カメラ53bに対応する子局53を検索して、例えば、電話番号や暗証番号など、当該子局53を呼び出すための情報を取得する。さらに、受信装置52aは、2つのISDN回線のうちの空いている回線を用いて、上記電話番号に電話をかけ、子局53の送信装置53aを電話呼び出しする(S62a)。送信装置53aが電話呼び出しにตอบสนองすると(S61b)、受信装置52aと送信装置53aとの間で、電話回線54を介する直接通信が可能になる。

【0131】さらに、S63aにおいて、受信装置52aが送信装置53aに予め定められた暗証番号を通知すると、S62bにおいて、送信装置53aは、受け取った暗証番号が予め定められた正規の暗証番号であるか否かを認証し、正規の暗証番号の場合、受信装置52aへ応答メッセージを送出する。

【0132】応答メッセージを受け取ると、受信装置52aは、S64aにて、インターネット網57を介して接続する際に用いられる通信パラメータ(アクセス情報)を、送信装置53aに連絡し、送信装置53aは、当該通信パラメータを受け取った後、電話回線54との回線接続を切断する(S63b)。これにより、受信装置52aと送信装置53aとの間の直接接続は切断される。

【0133】上記S64aにて送出される通信パラメータは、例えば、送信装置53aの最寄りのプロバイダ56の電話番号と、並びに、プロバイダ56のアカウントおよびパスワードなど、送信装置53aがダイヤルアップ接続する際に使用するダイヤルアップ情報を含んでいる。なお、受信装置52aは、各送信装置53aに予め対応付けられたダイヤルアップ情報を通知してもよいし、例えば、無線通信システムが発呼側と被呼側との双方に端末の現在位置を通知するサービスなどを用いて、受信装置52aが送信装置53aの位置を確認し、送信装置53aに応じたダイヤルアップ情報を通知してもよい。

【0134】さらに、上記通信パラメータには、例えば、暗号鍵と、受信装置52aのIPアドレスと、ftp(File Transfer Protocol)用のログイン名と、通信開始の条件となど、インターネット網57を介して、映像データを伝送する際に用いられる情報が含まれている。より詳細には、上記暗号鍵は、送信装置53aが映像データを暗号化の際に使用する暗号鍵であり、各接続毎に異なる使い捨てのものが使用される。また、通信開始の条件は、インターネット網57を介して、送信装置53aが受信装置52aへインターネット網57を介して接続する際の条件を示すものであり、例えば、以下に示す条件が挙げられる。第1の条件が選択された場合、受信装置52aが送信装置53aを電話回線54に

て呼び出し、直接通信が切断された後、子局53は、即座に通信を開始する。また、第2の条件が選択された場合、送信装置53aは、一定の時間間隔や指定した時間にて、自動的に通信を開始する。さらに、第3の条件が選択されると、送信装置53aは、送信装置53aに接続されたセンサ(図示せず)にて、何か異常を感知した場合に、自動的に通信を開始する。加えて、第4の条件が選択されると、送信装置53aは、各監視カメラ53bからの映像を常時画像処理し、映像に所定の変化が現れた場合に、自動的に通信を開始する。また、第5の条件が選択されると、送信装置53aは、図示しない通常の電話器(図示せず)から電話回線54を介して呼び出しを受けた場合、当該電話器との接続が切断された後で、自動的に通信を開始する。

【0135】上記S63bにて、受信装置52aと送信装置53aとの間の直接通信が切断されると、送信装置53aは、上記S64aにて通知された通信の開始条件が満たされるまで待機する(S64b)。

【0136】通信条件が満たされると、送信装置53aは、例えば、監視カメラ53bに写真を撮影するように指示したり、あるいは、監視カメラ53bから送られている映像のうち、最近の映像を選択するなどして、監視カメラ53bからの映像データを取得し、上記S64aにて通知された暗号鍵を用いて暗号化する。さらに、送信装置53aは、上記S64aにて指示されたプロバイダ56を介して、インターネット網57へダイヤルアップ接続する(S65b)。これにより、IPアドレスが割り当てられ、送信装置53aは、インターネット網57に接続される。なお、受信装置52aは、専用線58を介してインターネット網57へ常時接続されている。

【0137】続いて、S66bにて、送信装置53aは、インターネット網57を介して受信装置52aへftp接続を要求する(S66b)。なお、ftp接続要求は、例えば、上記S64aにて通知された受信装置52aのIPアドレスへ所定のコマンドを送出するなどして要求される。

【0138】また、受信装置52aは、ftp接続要求を受けると、ログイン名入力画面にて、乱数を送信装置53aに送信する(S65a)。なお、送信装置53aのIPアドレスは、上記S65bにて割り当てられるまで決定していないので、受信装置52aは、送信装置53aのIPアドレスを予め予測することができない。しかしながら、上記S66bにて、送信装置53aがftp接続を要求する際に受信装置52aへ送出したデータグラムには、送信元のIPアドレスとして、送信装置53aのIPアドレスが含まれている。したがって、当該IPアドレスヘデータグラムを送信することによって、受信装置52aは、何ら支障なく、インターネット網57を介して送信装置53aへ任意のデータを送信できる。

【0139】さらに、送信装置53aは、上記S64aにて通知された暗号鍵を用いて、受け取った乱数を暗号化して、パスワードを生成し、受信装置52aへ当該パスワードを送出する(S67b)。一方、受信装置52aは、受け取ったパスワードが、ログイン名に対応し、かつ、上記S64aにて通知したパスワードを用いて暗号化されたパスワードであるか否かを判定する。そして、ログイン名に対応して正しく暗号化されたパスワードであった場合、送信装置53aが正規の相手であると承認する(S66a)。

【0140】承認された送信装置53aは、上記S65bにて暗号化した映像データをftpプロトコルにて受信装置52aへ送信する(S68b)。当該映像データは、インターネット網57を介して、受信装置52aへ到達し、受信装置52aは、暗号化された映像データを受け取る(S67a)。さらに、送信が完了すると、送信装置53aは、プロバイダ56との回線接続を切断する(S69b)。これにより、受信装置52aと送信装置53aとの間のインターネット網57を経由した通信は完了する。

【0141】さらに、受信装置52aは、送信装置53aへ電話をかけて、呼出し音に基づいて、送信装置53aとプロバイダ56との間の回線接続が、正常に切断されているか否かを確認する(S68a)。具体的には、送信装置53aは、電話呼出しを受けた場合、例えば、1～2回など、所定の回数呼出し音になるまで、着呼しないように設定されている。この結果、受信装置52aが送信装置53aへ電話をかけた場合、所定数回の呼出し音が鳴らされる。通常の電話回線54では、被呼側となる送信装置53aが回線接続しているか否かによって呼出し音が異なる。したがって、受信装置52aは、呼出し音によって、送信装置53aとプロバイダ56との回線接続が切断されているか否かを確認できる。

【0142】例えば、話し中ではないことを示す通常の呼出し音が鳴った場合、受信装置52aは、送信装置53aがインターネット網57への接続を正しく切断できたと判断する。一方、話し中を示すツーツーという音が鳴った場合、受信装置52aは、送信装置53aがインターネット網57へ接続中であると判断する。この場合、受信装置52aは、例えば、先程まで通信していた送信装置53aのIPアドレスへ、インターネット網57経由で切断コマンドを送出するなどして、送信装置53aへ回線切断を指示できる。また、受信装置52aの通知に応じて、端末52bの利用者が、監視カメラ53bの設置場所へ赴いて回線接続を切断するなどしてもよい。

【0143】いずれの場合であっても、親局52側は、子局53における回線切断の失敗を把握して、適切な処置を講じることができる。この結果、回線切断の失敗に起因する無駄な通信費用の発生を確実に防止できる。な

お、上記所定の回数までに、受信装置52aが電話呼出しを中止すれば、通話料金は無料である。

【0144】また、S69aにおいて、受信装置52aは、受け取った映像データを復号し、ftpプロトコルにて、例えば、図9に示す端末52bなどの他の機器へ、復号された映像データを送出する。これにより、映像データは、端末52bに表示され、端末52bの利用者は、監視カメラ53bの設置場所の映像を確認できる。

【0145】この結果、子局53がダイヤルアップ接続されている場合であっても、親局52は、任意の時点で、監視カメラ53bからの映像を確認できると共に、例えば、無断駐車を発見したときなど、何らかの異常があったとき、特定の監視カメラ53bを重点的に監視できる。したがって、無断駐車されている駐車スペースを柵などで囲ったり、警備会社に連絡するなど、異常に応じた処理を講じることができる。

【0146】ところで、上述したように、インターネット網57を構成する通信機器は、送信元の通信機器のIPアドレスに拘わらず、近隣の通信機器からデータグラムを受け取っている。したがって、受信装置52aは、受信装置52aの処理能力および専用線58の通信容量の範囲内であれば、複数の送信装置53aからの映像データをインターネット網57経由で受け取ることができる。さらに、受信装置52aは、インターネット網57経由の接続と、電話回線54を介した直接接続とを同時に維持できる。したがって、受信装置52aは、インターネット網57経由で映像データを受け取っている間であっても、他の送信装置53aを電話呼出して、映像の取得を指示できる。

【0147】なお、上記各ステップでは、監視カメラ53bが取得した映像をインターネット網57経由で受信装置52aへ送出する場合について説明している。ただし、例えば、プロバイダ56が混雑している場合など、インターネット網57経由のデータ伝送が難しい場合、送信装置53aは、受信装置52aを電話呼出して、電話回線54を介した直接通信によって映像を伝送することもできる。この場合は、インターネット網57へのアクセスや暗号化を必要としないため、送信装置53aは、より速い時点で、受信装置52aに映像を伝送できる。

【0148】また、上記各ステップにおいて、受信装置52aおよび送信装置53aは、ftpプロトコルを用いて、映像データを伝送しているが、これに限るものではない。インターネット網57経由でデータを伝送できる方法であれば、例えば、電子メールなど、他の方法を用いて映像データを伝送できる。ただし、ftpプロトコルでは、受信装置52aおよび送信装置53aの双方で、データを伝送できたか否かを確実に確認できる。したがって、データ伝送に失敗した場合にデータを再送す

るなど、適切な処置を講ずることができる。

【0149】さらに、上記S68aでは、受信装置52aは、呼出し音によって、送信装置53aの回線接続が切断されているか否かを確認しているが、これに限るものではない。例えば、受信装置52aが送信装置53aを電話呼出して直接通信することによって、回線接続が切断されているか否かを確認してもよい。ただし、呼出し音によって回線接続の切断を確認した場合、通信費用がかからないので、直接通信する場合に比べて、通信費用をさらに削減できる。

【0150】ここで、上記監視カメラシステム51を運営する際の費用の一例について、簡単に説明する。上記監視カメラシステム51では、監視カメラ53bから得られた映像に基づいてナンバープレートを確認するので、例えば、圧縮後で、1枚あたり約500kbyte程度の高精度な映像が必要である。したがって、データの伝送速度が64kbp/sのISDN回線を用いて、当該映像を直接通信する場合、1枚の映像の伝送には、約62秒程度必要とする。ここで、親局52と子局53とが東京と名古屋とに配されている場合には、通信費用が40円程度となる。この結果、映像の取得頻度を1時間に1回程度とすると、1年間で、約350、400円程度必要となる。同様の条件で、伝送速度が33、6kbp/sのアナログ回線にて直接通信する場合の費用を算出すると、1回の伝送に、120秒程度で必要であることから、通信費用は、1回あたり、120円程度、1年で、約700、800円程度が必要となる。また、子局53が専用線にてインターネット網57へ接続する場合、最近では、年間40万円程度の専用線利用料が必要となる。

【0151】これに対して、インターネット網7経由であれば、プロバイダ6が子局53と市内通話料金で通話可能な範囲内であれば、1回の伝送に要する時間が180秒以内であることから、1回あたりの通信費用は、10円となり、1年で、約87、600円程度となる。さらに、プロバイダ6の利用料金を1年あたり60、000円程度とすると、1年あたりの通信費用は、147、600円程度となる。この結果、上記監視カメラシステム51において、1か所の子局53あたりの通信費用は、通常回線にて直接通信する場合に比べて、約56万円程度(約79%)、ISDNの場合に比べても、約20万円(約57%)程度と大幅に削減できる。さらに、親局52で必要とする映像の精度や枚数、あるいは通信頻度が増えるに伴って、監視カメラシステム51の通信費用の方が、より割安となる。また、子局53が専用線接続する場合と比較すると、上記監視カメラシステム51において、1か所の子局53あたりの通信費用は、年間で約25万円(約63%)程度削減できる。

【0152】なお、上述の通信費用は、あくまで一例であり、使用する通信回線の料金体系や、プロバイダ6の

料金体系などによって大きく異なる。ただし、上述したように、通信に要する設備などの面から、通信回線よりもネットワークの方が通信費用を削減しやすい。さらに、ネットワークにて通信する場合でも、専用線による接続よりも、ダイヤルアップ接続の方が通信費用を削減しやすい。したがって、上記監視カメラシステム51の通信費用は、子局53が専用線接続する場合、および、親局52と子局53とが直接通信する場合のいずれと比べても、大幅に廉価であることが多い。

【0153】〔第5の実施形態〕上記第4の実施形態では、親局52が専用線58によってインターネット網57に常時接続されている場合について説明している。これに対して、図12に示すように、本実施形態では、親局52が、図1に示す通信機器2と同様に、プロバイダ55を介してインターネット網57へダイヤルアップ接続する場合について説明する。

【0154】なお、本実施形態に係る受信装置52aは、第4の実施形態と同じハードウェア構成であり、子局53と通信する際、2本のISDN回線のうちの一方を用いて、プロバイダ55へダイヤルアップ接続する。また、子局53など、監視カメラシステム51の残余の構成は、第4の実施形態の構成と同様である。したがって、第4の実施形態と同じ機能を有する部材には、同じ参照番号を付して説明を省略し、以下では、親局52および子局53の動作について、図13に示すフローチャートに基づき詳細に説明する。

【0155】すなわち、本実施形態では、図11に示す各ステップに加えて、S71aおよびS72aの両ステップが設けられている。S61aの後に設けられたS71aにおいて、受信装置52aは、インターネット網57と接続されていない場合、プロバイダ55を介して、インターネット網57にダイヤルアップ接続する。これにより、受信装置52aは、続くS64aにて通知する自らのIPアドレスを得ることができる。

【0156】なお、受信装置52aは、ISDN回線に接続されている。したがって、上述のS62aにおいて、受信装置52aは、一方の回線にて、インターネット網57との接続を保ったまま、他方の回線を用いて送信装置53aを呼び出すことができる。この結果、上記S71aにて受信装置52aに割り当てられたIPアドレスは、S64b以降も受信装置52aに割り当てられている。

【0157】一方、S67aの後に設けられたS72aにおいて、受信装置52aは、プロバイダ55との回線接続を切断する。これにより、受信装置52aは、インターネット網57から切り離される。

【0158】上記構成では、受信装置52aがインターネット網57へダイヤルアップ接続している。したがって、受信装置52aが専用線58にて接続される第4の実施形態に比べて、さらに、通信費用を削減できる。

【0159】なお、上記構成では、上述のS64aにて通知した通信開始条件のうち、受信装置52aが通信開始時点进行管理できない第2ないし第5の条件を選択すると、送信装置53aが映像を送信しようとしたときに受信装置52aがインターネット網57へ接続されていない場合がある。したがって、これらの条件を選択する場合、送信装置53aは、本発明に係るダイヤルアップ接続通信機器の呼び出し方法を用いて、受信装置52aを呼び出す必要がある。この場合、受信装置52aおよび送信装置53aは、第1ないし第2の実施形態に示すように、電子メールを利用したり、サーバを経由するなどして、白らのIPアドレスを相手に通知する。

【0160】ところで、上記第4および第5の実施形態では、監視カメラシステムの適用例として、無人駐車場の監視カメラに撮影を指示し、撮影した映像を取得する場合を例にして説明したが、本発明に係る監視カメラシステムは、これに限らず、種々の用途に使用できる。例えば、全国のあちこちに保有するビルや倉庫に監視カメラを配置すれば、管理会社は、親局となる1か所の事務所から、ビルや倉庫を監視できる。同様に、ドライブインの無人店舗や無人のコンビニを、本社から監視する用途にも適用できる。また、金融機関が無人店舗を管理したり、電力会社が、遠隔地の無人変電所やダムなどを本社から管理したりする際にも使用できる。さらに、装置の納入場所に監視カメラを配すれば、装置メーカーの本社にて、納入場所の状態を知ることができるので、納入した装置をリモートメンテナンスの際に役立てることができる。あるいは、各地の火山に無人カメラを配置すれば、大学の研究所から、これらの火山活動を監視することもできる。また、ファーストフード、レストラン、コンビニチェーンなどに監視カメラを配し、各店舗内部を撮影したデータを本社へ送信することによって、時間帯毎の客入り、客人数、構成、年齢層、あるいは、座席場所など、種々のマーケット情報を本社にて収集できる。

【0161】いずれの場合であっても、監視するための人材を派遣する必要がないので、人件費を削減できる。加えて、監視したデータは、インターネットなどのネットワークを介して伝送されるので、電話回線などの通信回線を使用する場合に比べて通信費用を大幅に削減できる。さらに、通信回線にて監視カメラを呼び出すので、親局は、所望の時点において、監視カメラに映像の取得を指示できる。これらの結果、任意の時点の映像を取得可能な監視カメラシステムを少ない予算で実現できる。

【0162】また、上記第4および第5の実施形態では、子局53の制御対象が監視カメラ53bである場合を例にして説明しているが、これに限るものではない。例えば、子局53が、各種センサなどを用いて取得したデータを親局52へ送出する場合や、親局52の指示に基づいて、子局53が、モータやポンプなどを制御する場合など、種々の機器を制御対象とする監視制御システ

ムに本発明を適用できる。ただし、監視カメラ53bが取得した映像を伝送する場合のように、伝送されるデータ量が多い場合は、通信に要する時間が長いので、通信回線による直接通信にて当該データを送出すると、通信費用が高騰する。したがって、監視カメラシステム51に本発明を適用した場合の効果は特に大きくなる。

【0163】上記第1ないし第5の各実施形態に示すように、ダイヤルアップ接続通信機器の呼び出し方法は、発呼側および被呼側の通信機器が、それぞれ電話回線に接続されていると共に、少なくとも被呼側の通信機器が、当該電話回線を介して、インターネット網やパソコン通信などのネットワークにダイヤルアップ接続される通信システムに適用される呼び出し方法であり、ネットワークを介して通信する前に、電話回線を用いて、発呼側の通信機器が被呼側の通信機器へ接続要求を伝えることを特徴としている。

【0164】これにより、被呼側の通信機器がネットワークに接続されていない場合であっても、ネットワークを介して通信する際には、被呼側の通信機器をネットワークへ接続させることができる。したがって、両通信機器は、所望のタイミングで確実に通信を開始できる。これにより、従来に比べて、被呼側の通信機器の即応性を向上でき、リアルタイム通信が可能となる。

【0165】また、少なくとも被呼側の通信機器は、ダイヤルアップ接続によってネットワークに接続されている。したがって、ネットワークを介して通信する際の費用は、専用線を介してネットワークに接続する場合や、電話回線を介して直接通信する場合に比べて、大幅に低減できる。特に、海外など、両通信機器を設置している場所が離れている場合には、電話回線を介して直接通信する場合の費用は、極めて高いので効果が大きい。

【0166】なお、上記各実施形態では、両通信機器がそれぞれダイヤルアップ接続する場合について説明したが、これに限るものではない。例えば、第4の実施形態に示すように、少なくとも被呼側の通信機器がダイヤルアップ接続する通信システムであれば、第1ないし第5の各実施形態と同様の効果が得られる。

【0167】また、上記各実施形態では、発呼側の通信機器が電話回線を用いて接続要求を通知しているが、これに限るものではない。例えば、船舶無線など、他の通信回線を用いてもよい。被呼側に接続要求を通知できるものであれば、各実施形態と同様の効果が得られる。

【0168】さらに、上記各実施形態では、発呼側の通信機器が1台の通信機器を呼び出す場合について説明しているが、これに限らず、複数の通信機器を呼び出してもよい。1台の通信機器を呼び出す場合と同様に、複数の通信機器を順番に電話回線で呼び出すことによって、多数の通信機器がネットワーク上で同時に通信できる。この場合、発呼側の通信機器の使用者が会議の招集者となる。なお、この場合、複数の通信機器が同時に通信可

能なネットワーク会議ソフトが必要となるが、このような製品は、既に一般的に使用されている。

【0169】ところで、上記各実施形態に係る通信機器は、使用者名や通信内容など、ネットワークで伝送するデータの少なくとも一部を暗号化しているが、これに限るものではない。ネットワークで通信する際、特に暗号を施さず、平文のままデータを送出してもよい。

【0170】ただし、平文のままデータを送出する場合、ネットワークを伝送されるデータは、盗聴あるいは改ざんされる虞れがある。特に、ネットワークとして、インターネット網などを使用する場合には、発信側および受信側の通信機器がデータの伝送路を指定できない。したがって、盗聴などが容易で、通信を妨害される危険性が高い。

【0171】これに対して、上記各実施形態では、ネットワークでデータを送信する際、例えば、相手の公開鍵や共通の暗号鍵など、種々の暗号鍵によって、データの少なくとも一部を暗号化している。これにより、正規の通信相手ではない第三者から、データの少なくとも一部を隠蔽できるので、通信妨害に対する安全性を向上できる。

【0172】なお、暗号化するデータは、例えば、通信内容そのもの、両通信機器の使用者名あるいはアドレスなどが挙げられる。ただし、暗号化するデータ量が増大するに従って、両通信機器の負担が増大するので、通信の重要度を考慮して、一部のデータのみを暗号化してもよい。一般に、使用者名やアドレスなどが第三者に傍聴されると、通信内容の重要性を推測されやすい。したがって、第1および第2の実施形態に示すように、画像や音声などの通信に先立って、使用者名やアドレスなどを送信する場合には、これらを暗号化することが特に望まれる。これにより、両通信機器の負担を余り増加させることなく、通信妨害に対する安全性を向上できる。

【0173】各通信機器が暗号鍵を取得する方法は、種々の方法が考えられる。例えば、郵送など、他の通信手段によって、予め相手に通知し、例えば、図2に示すFlashメモリ11など、各通信機器の記憶手段へ格納しておいてもよい。ただし、この場合、各通信機器の使用者は、通信に先立って、相手から通知された暗号鍵を、それぞれの通信機器へ設定する必要がある。暗号鍵は、各通信機器毎に用意されるので、通信相手が増加するに従って、設定時の手間も増大する。さらに、暗号鍵は、通信妨害に対する安全性を向上させるために、必要に応じて変更しなければならない。したがって、各通信機器の使用者は、自らの暗号鍵を変更する度に、全ての通信相手に対して、新たな暗号鍵を通知する必要がある。

【0174】これに対して、上記各実施形態では、接続要求時に通信回線にて、暗号鍵を通知している。なお、暗号鍵が公開鍵と秘密鍵とから構成されている場合は、

通信回線にて、互いの公開鍵を交換する。また、共通の暗号鍵を用いる場合には、一方の通信機器が他方に通知すればよい。この構成では、接続要求毎に暗号鍵を通知するので、前回通信したときと暗号鍵を変更した場合であっても訂正が容易である。したがって、接続要求毎に暗号鍵を容易に変更でき、通信妨害に対する安全性をさらに向上できる。加えて、電話回線を用いて、接続要求の通知と暗号鍵の送付との双方を一括して行っている。したがって、両者を個別に行う場合に比べて、電話回線を接続する手間を削減できる。

【0175】さらに、暗号鍵と暗号化されたデータとは、互いに異なる通信手段によって伝送される。したがって、第三者が通信の妨害を試みる場合、双方の通信を傍受する必要があり、単一の通信手段にて、暗号鍵とデータとを送信する場合に比べて、通信妨害に対する安全性を向上できる。なお、通信回線としては、暗号鍵の盗聴を防止するために電話回線など、比較的傍受しにくい通信回線を使用することが望まれる。

【0176】ところで、第2の実施形態に示すように、両通信機器がネットワークに設けられたサーバを介して通信する場合には、上記構成に加えて、両通信機器がサーバに登録名を登録し、両通信機器が相手の登録名をサーバへ通知して、通信相手を選択する必要がある。

【0177】この場合、サーバに登録された登録名は、公開されているので、使用者名をそのまま登録すると、通信妨害に対する安全性を低下させる虞れがある。また、サーバに登録されている登録名のうち、所望の登録名を選択する際に手間がかかる。この場合には、上記公開鍵を用いて使用者名を暗号化して、サーバに登録すればよい。これにより、使用者名を第三者から隠蔽できる。

【0178】ところで、第2の実施形態に示すように、サーバを設ける構成では、サーバを別に設ける費用や維持費などが必要となる。また、サーバが混み合っている場合には、両通信機器間で通信できなくなる虞れがある。

【0179】これに対して、第1の実施形態では、上記第2の実施形態とは異なり、両通信機器が互いにネットワークを介して直接通信できる方法を提供している。具体的には、ダイヤルアップ接続した際、被呼側の通信機器が自らのアドレスを取得し、電子メールにて発呼側の通信機器へ送信する工程が設けられている。これにより、第2の実施形態とは異なり、特にサーバを設けることなく、両通信機器は、ネットワークを介して通信できる。この結果、通信に要する費用をさらに削減できる。また、サーバの混雑に関わらず、両通信機器は、確実に通信できる。

【0180】ところで、ネットワークを介する通信が終了すると、ダイヤルアップ接続通信機器は、ネットワークとの接続を切断する。ここで、ダイヤルアップ接続通

信機器がネットワークとの回線切断に失敗すると、当該ダイヤルアップ接続通信機器は、ネットワークに接続され続けるので、通信費用が不所望に高騰する。特に、例えば、ダイヤルアップ接続通信機器が監視制御システムの子局である場合など、ダイヤルアップ接続通信機器の周囲に使用者がいない場合には、回線切断に失敗したことを把握しにくい。したがって、回線切断に失敗した場合、当該ダイヤルアップ接続通信機器が不所望にネットワークに接続される期間が長くなりがちであり、無駄な通信費用が増大する虞れが大きい。

【0181】これに対して、第4および第5の実施形態に示すように、上記発呼側の通信機器は、ネットワーク経由の通信が終了した後で、通信回線を介して、ダイヤルアップ接続通信機器を呼び出し、正常にダイヤルアップ接続が切断されたことを確認している。この結果、回線切断の失敗に起因する無駄な通信費用を削減できる。

【0182】ところで、本発明に係るダイヤルアップ接続通信機器の呼び出し方法を適用する通信システムの一例として、上記第1ないし第3の実施形態では、映像や音声などを伝送するインターネット電話システムについて説明し、第4および第5の実施形態では、監視カメラシステムなどの監視制御システムについて説明しているが、これに限るものではない。インターネットVPN（Virtual Private Network）を構築して、任意のデータを送受する場合に広く適用できる。

【0183】ただし、当該ダイヤルアップ接続通信機器の呼び出し方法を用いることによって、所望のタイミングで通信の開始が可能で、かつ、通信費用の削減できる通信システムを構築できるので、例えば、インターネット電話システムや監視制御システムなどのように、即応性が強く要求される場合に、特に好適である。

【0184】具体的には、監視制御システムでは、一般に、子局が、親局から離れた場所に設置されており、かつ、親局が数多くの子局を監視制御する。したがって、親局と子局とが通信する際の費用は、増大しがちであり、通信費用の削減が強く要求されている。一方、監視制御システムでは、指示の遅れが事故の拡大に直結するので、子局は、親局の指示に即座に応答しなければならない。したがって、ダイヤルアップ接続により接続されるネットワークのみを介して、子局が親局と通信する場合、子局が親局の指示に即応できず、事故を拡大させる虞れがある。これらの結果、監視制御システムでは、親局の指示に対する子局の即応性を保ったまま、通信費用を削減することが強く求められている。したがって、親局が子局を呼び出す際に、本発明に係るダイヤルアップ接続通信機器の呼び出し方法を適用した場合、特に効果的である。

【0185】

【発明の効果】請求項1の発明に係る通信ダイヤルアップ接続通信機器の呼び出し方法は、以上のように、ネッ

トワークとは別に設けられ、上記ダイヤルアップ接続通信機器を呼び出し可能な通信回線によって、発呼側の通信機器がダイヤルアップ接続通信機器へ接続要求を伝える第1工程と、接続要求を受けたダイヤルアップ接続通信機器が、上記ネットワークへダイヤルアップ接続する第2工程と、上記ネットワークを介して、発呼側の通信機器とダイヤルアップ接続通信機器とが通信する第3工程とを含んでいる構成である。

【0186】上記構成では、ダイヤルアップ接続通信機器がネットワークに接続されていない場合であっても、上記第3工程における通信時には、当該ダイヤルアップ接続通信機器をネットワークへ接続させることができる。それゆえ、安い料金で通信可能なダイヤルアップ接続通信機器において、所望のタイミングで確実に通信を開始でき、リアルタイムに通信できるという効果を奏する。

【0187】請求項2の発明に係るダイヤルアップ接続通信機器の呼び出し方法は、以上のように、請求項1記載の発明の構成において、上記第3工程は、上記発呼側の通信機器およびダイヤルアップ接続通信機器のうちで送信側の通信機器が、当該第3工程にて送出するデータの少なくとも一部を暗号化して送出する暗号工程と、受信側の通信機器が、暗号化されたデータを復号する復号工程とを含んでいる構成である。

【0188】上記構成では、通信内容のうち、少なくとも一部は、暗号化によって、発呼側の通信機器およびダイヤルアップ接続通信機器以外の第三者から隠蔽されている。この結果、通信内容を暗号化せず、平文のまま伝送する場合に比べて、通信妨害に対する安全性を向上できるという効果を奏する。

【0189】請求項3の発明に係るダイヤルアップ接続通信機器の呼び出し方法は、請求項2記載の発明の構成において、上記第1工程は、発呼側の通信機器あるいはダイヤルアップ接続通信機器が、暗号化の際に使用される暗号鍵を相手に通知する工程を含んでいる構成である。

【0190】上記構成では、接続要求の通知と暗号鍵の送付との双方を一括して行っている。これにより、通信回線の接続する手間を増加させることなく、暗号鍵を接続毎に伝送でき、暗号鍵を変更した場合の手間を削減できるという効果を奏する。

【0191】さらに、暗号鍵と暗号化されたデータとは、互いに異なる通信手段によって伝送される。この結果、盗聴やデータの改ざんなど、通信妨害に対する安全性をさらに向上できるという効果を併せて奏する。

【0192】請求項4の発明に係るダイヤルアップ接続通信機器の呼び出し方法は、以上のように、請求項1、2または3記載の発明の構成において、上記第3工程は、上記両通信機器が、通信を中継するサーバへ自らを示す登録名をそれぞれ通知する工程と、上記両通信機器

が、相手の登録名を上記サーバへ通知して、相手の通信機器を選択する工程と、上記サーバが選択された通信機器間の通信を中継する工程とを含んでいる構成である。

【0193】それゆえ、両通信機器は、ネットワークに設けられたサーバを介して、所望のタイミングで確実に通信を開始でき、リアルタイムに通信できるという効果を奏する。

【0194】請求項5の発明に係るダイヤルアップ接続通信機器の呼び出し方法は、以上のように、請求項1、2または3記載の発明の構成において、上記第3工程は、ダイヤルアップ接続通信機器が、現接続における自らのアドレスを取得する工程と、電子メールによって、ダイヤルアップ接続通信機器が、発呼側の通信機器へ自らのアドレスを通知する工程と、発呼側の通信機器およびダイヤルアップ接続通信機器が、互いのアドレスにより相手特定して通信する工程とを含んでいる構成である。

【0195】それゆえ、請求項4の構成のように、特にサーバを設けることなく、両通信機器は、ネットワークを介して通信できる。この結果、請求項4記載の発明の効果に加えて、通信に要する費用をさらに削減できると共に、サーバの混雑に関わらず、確実に通信できるという効果を奏する。

【0196】請求項6の発明に係るダイヤルアップ接続通信機器の呼び出し方法は、以上のように、請求項1、2、3、4または5記載の発明の構成において、さらに、上記第3工程の後で、上記発呼側の通信機器がダイヤルアップ接続通信機器を上記通信回線にて直接呼び出して、当該ダイヤルアップ接続通信機器が当該通信回線との回線接続を正常に切断したか否かを確認する第4工程を含んでいる構成である。

【0197】それゆえ、発呼側の通信機器は、ダイヤルアップ接続通信機器の回線切断失敗を確実に認識でき、回線切断の失敗に起因する無駄な通信費用の発生を確実に防止できるという効果を奏する。

【0198】請求項7の発明に係る監視制御システムは、以上のように、親局は、呼び出し可能な通信回線を介して上記子局を呼び出し、接続要求を伝えた後で、上記通信回線とは別に設けられたネットワーク経由で上記子局と通信する親局通信手段を備え、上記子局は、上記通信回線を介して、上記接続要求を受け取った後で、上記ネットワークにダイヤルアップ接続して、当該ネットワーク経由で上記親局と通信する子局通信手段を備えている構成である。

【0199】上記構成において、親局通信手段が呼び出し可能な通信回線を用いて子局を呼び出した後、子局通信手段は、安価に通信可能なダイヤルアップ接続にてネットワークに接続し、当該ネットワークを介して、データを送受する。この結果、親局の指示に対して、子局が即応可能でありながら、子局と親局との間の通信費用

を大幅に削減可能な監視制御システムを実現できるという効果を奏する。

【図面の簡単な説明】

【図1】本発明の一実施形態を示すものであり、通信システム全体の要部構成を示すブロック図である。

【図2】上記通信システムの発呼側および被呼側の通信機器に設けられた接続器の要部構成を示すブロック図である。

【図3】上記通信機器の一変形例を示すものであり、通信機器の接続関係を示すブロック図である。

【図4】上記通信システムにおいて、呼び出し時における発呼側および被呼側双方の通信機器の動作を示すフローチャートである。

【図5】本発明の他の実施形態を示すものであり、通信システム全体の要部構成を示すブロック図である。

【図6】上記通信システムにおいて、呼び出し時における発呼側および被呼側双方の動作を示すフローチャートである。

【図7】本発明のさらに他の実施形態を示すものであり、通信システム全体の要部構成を示すブロック図である。

【図8】上記通信システムにおいて、呼び出し時における発呼側および被呼側双方の動作を示すフローチャートである。

【図9】本発明のさらに他の実施形態を示すものであり、監視制御システムの要部構成を示すブロック図である。

【図10】上記監視制御システムにおいて、受信装置の要部構成を示すブロック図である。

【図11】上記監視制御システムにおいて、親局が子局を呼び出す際の動作を示すフローチャートである。

【図12】本発明のさらに他の実施形態を示すものであり、監視制御システムの要部構成を示すブロック図である。

【図13】上記監視制御システムにおいて、親局が子局を呼び出す際の動作を示すフローチャートである。

【符号の説明】

2・22・32・42	通信機器
3・33・43	通信機器（ダイヤルアップ接続通信機器）
4・34・44・54	電話回線（通信回線）
7・37・57	インターネット網（ネットワーク）
38	サーバ
48・58	回線（ネットワーク）
52	親局（通信機器）
52a	受信装置（親局通信手段）
53	子局（ダイヤルアップ接続通信機器）
53a	送信装置（子局通信手段）

【図1】

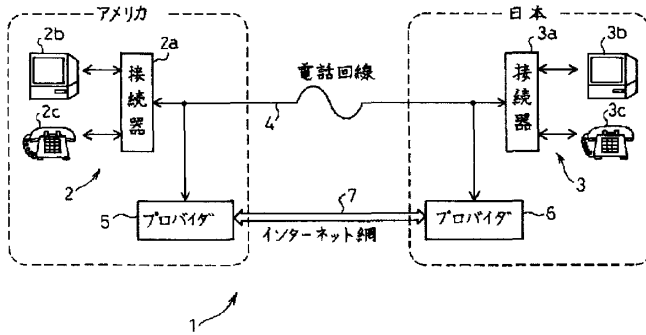

【図3】

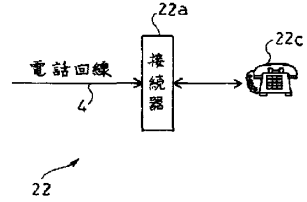

【図2】

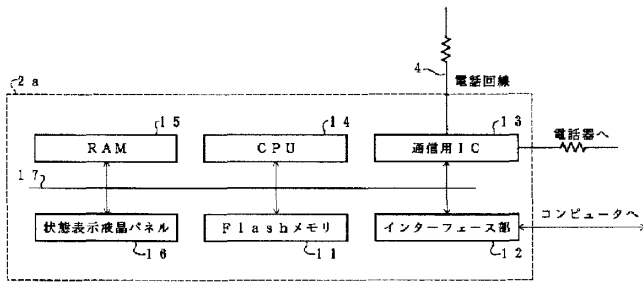

【図5】

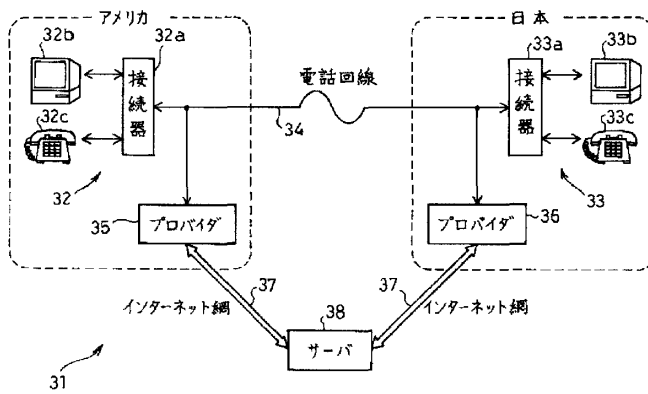

【図4】

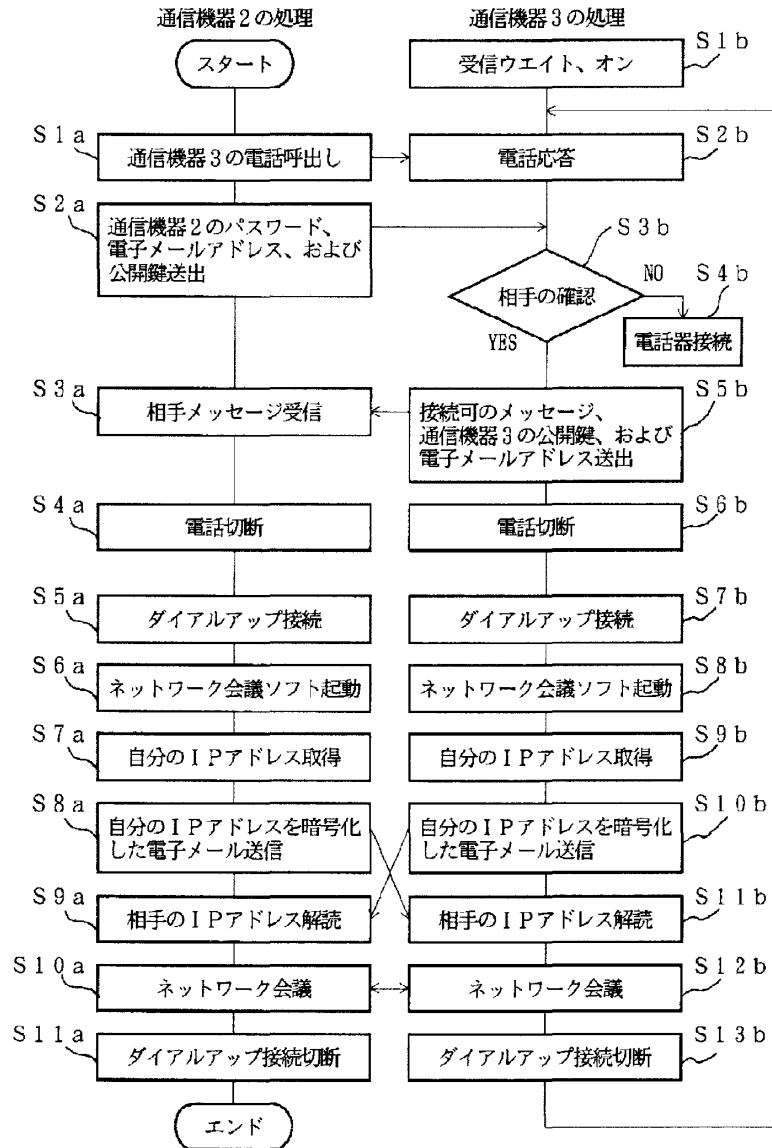

【図6】

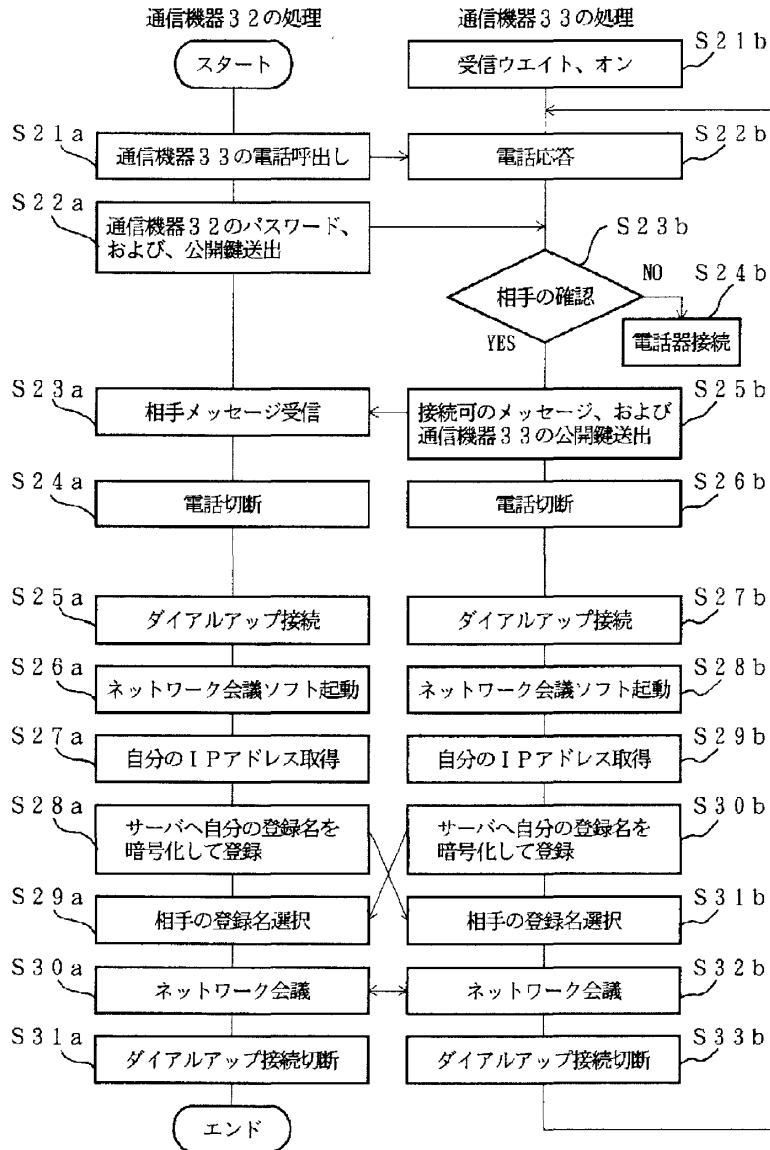

【図7】

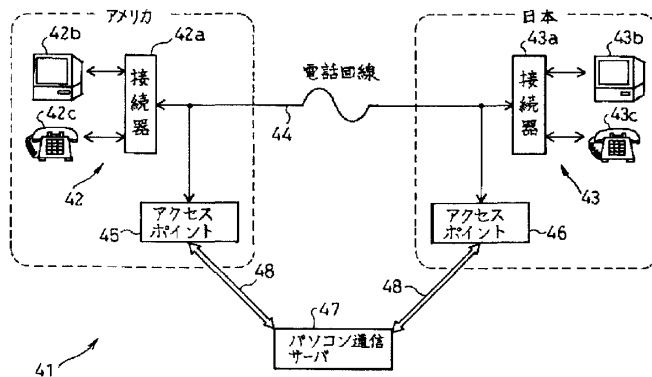

【図9】

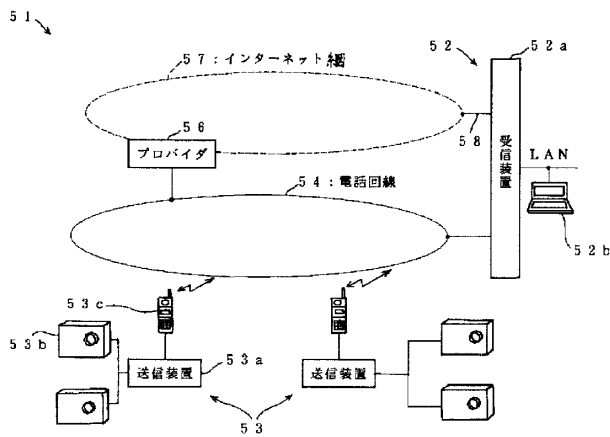

【図10】

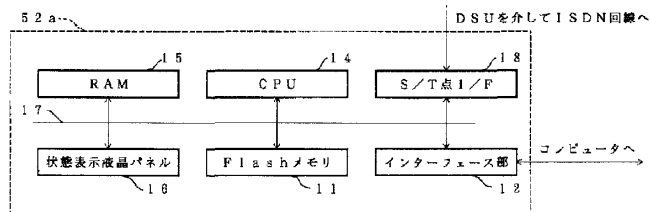

【図8】

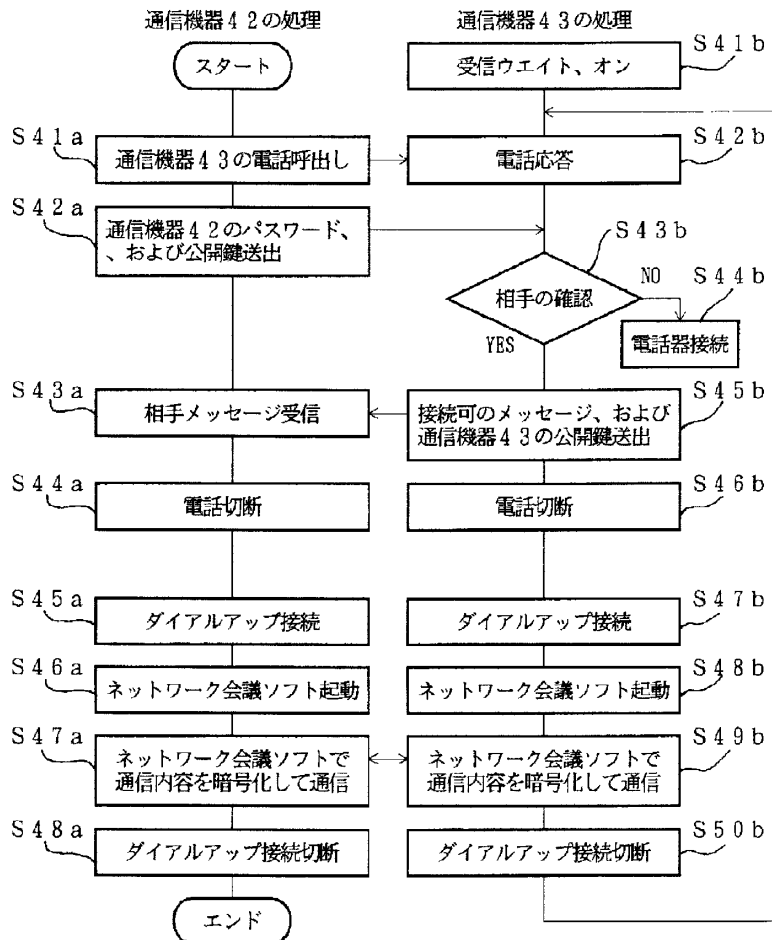

【図11】

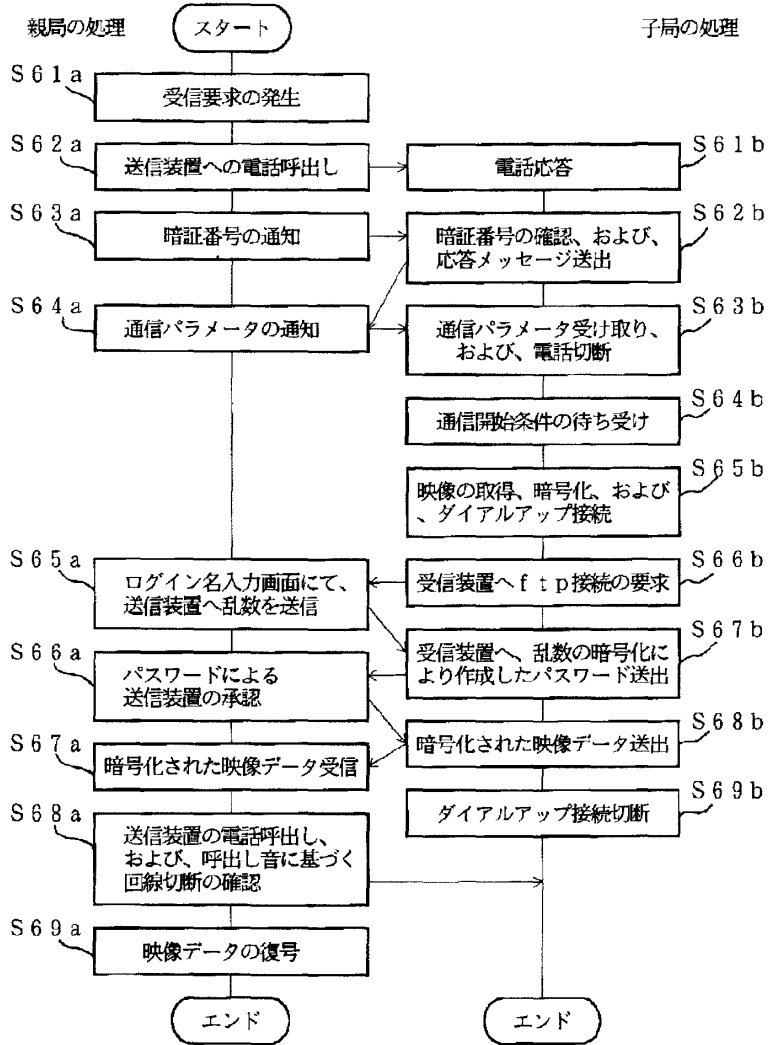

【図12】

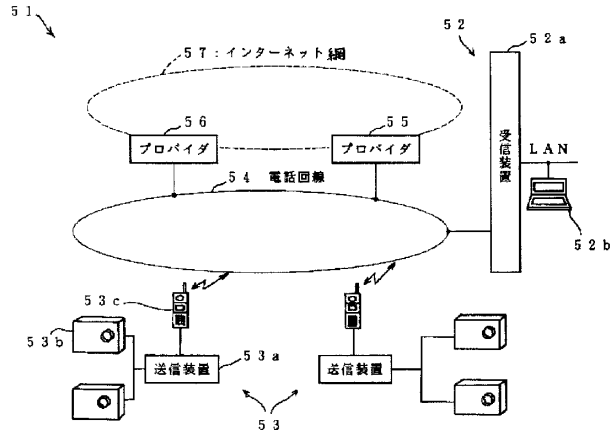

【図13】

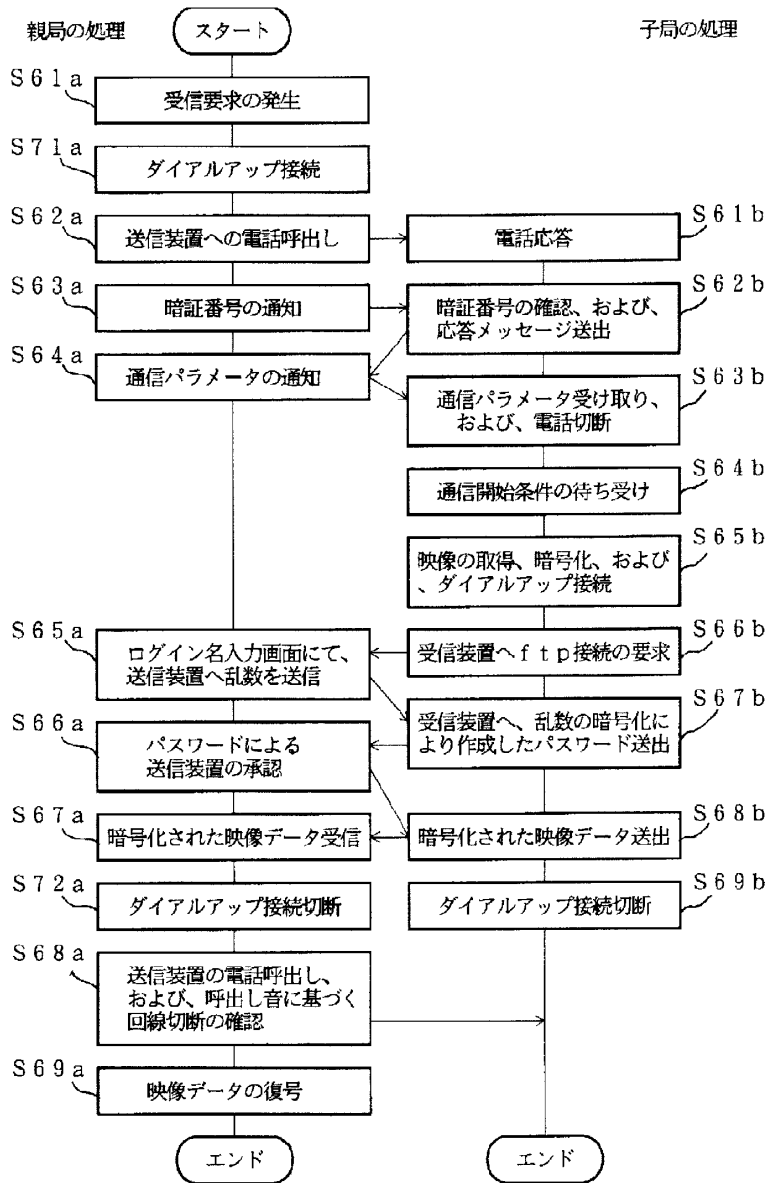

フロントページの続き

(51)Int. Cl.	識別記号	F I		
H 0 4 L	12/58	H 0 4 L	9/00	6 7 3 A
H 0 4 M	1/66		11/02	Z
	3/42		11/20	1 0 1 B
H 0 4 Q	9/00	3 1 1		

(19) Japan Patent Office (JP)

(12) Publication of Patent Application

(11) Publication Number of Patent Application: Hei-10-66058

(43) Date of Publication of Application: March 6, 1998

(51) Int. Cl.⁶

H04N 7/18

G06F 17/30

G08B 5/00

H04H 1/00

H04N 7/10

H04N 7/18

G08B 5/00

H04N 1/00

H04N 7/10

G06F 15/40

Identification Number

Intraoffice Reference Number

FI

D

Z

E

370C

Request for Examination: made

Number of Claims: 9 FD (15 pages in total)

(21) Application Number Hei-8-355003

(22) Application Date: December 20, 1996

(31) Priority Number: Hei-8-172930

(32) Priority Date: June 11, 1996

(33) Priority Country: Japan (JP)

(71) Applicant: 595100934

Masanobu Kujirada

Kujirada Bldg., 1F

2-1-11, Tokuchikarasin-machi,
Ogura-minami-ku, Kitakyushu-shi, Fukuoka

(72) Inventor: Masanobu Kujirada

Kujirada Bldg., 1F
2-1-11, Tokuchikarasin-machi,
Ogura-minami-ku, Kitakyushu-shi, Fukuoka

(54)[TITLE OF THE INVENTION]

INTERACTIVE GRAPHICS DELIVERY SYSTEM

(57)[ABSTRACT]

[Problem to be solved]

To provide a system for delivering interactive graphics, which can deliver a real circumstance on an arbitrary position through an image in real time to a user.

[Solution]

The present system includes an image input means that is provided at each spot in order to input interactive graphics on many spots that can be disclosed to a public; an image transmission means for transmitting each interactive graphics to be inputted from these respective image input means with a wire or without a wire; an interactive spot data base for recording an identification data in order to identify respective spots each other while relating them to a predetermined key; a key input means for inputting the predetermined key; a retrieving means for retrieving the identification data of an interactive graphics at the corresponding spot from the interactive spot data base on the basis of the key inputted from this key input means; an image receiving means for receiving the corresponding interactive graphics from each image transmission means on the basis of the identification data retrieved by this retrieving means; and a display means for outputting this received interactive graphics.

[Claim(s)]

[Claim 1]

An interactive graphics delivery system, comprising:

an image input means that is provided at each live spot in order to constantly input interactive graphics on many live spots that can be disclosed to a public in real time, respectively;

a map database means for recording respective spots on a map and interactive

graphics identification data in order to identify the respective interactive graphics from each other while relating them with each other;

an image importing means for importing the corresponding interactive graphics from the image input means on line on the basis of the interactive graphics identification data corresponding to a certain spot on the map that is displayed by the map database means; and

a display means for displaying the interactive graphics that is imported by this image importing means in real time.

[Claim 2]

An interactive graphics delivery system, comprising:

an image input means that is provided at each live spot in order to constantly input interactive graphics on many live spots that can be disclosed to a public in real time, respectively;

a map database means for recording respective spots on a map and interactive graphics identification data in order to identify the respective interactive graphics from each other while relating them with each other;

a map data extracting means for extracting map data in order to indicate a map of a predetermined area including a live spot of the corresponding interactive graphics from the map database means, when a certain interactive graphics is displayed, using interactive graphics identification data for identifying that interactive graphics as a key; and

a display means for displaying a map on the basis of the map data that is extracted by this map data extracting means.

[Claim 3]

An interactive graphics delivery system, comprising:

an image input means that is provided at each live spot in order to constantly input interactive graphics on many live spots that can be disclosed to a public in real time, respectively;

an interactive graphics identification database means for recording interactive graphics identification data in order to identify the respective interactive graphics from each other while relating them to retrieving data composed of a character string, a symbol string, a figure, or an image or the like;

a retrieving data input means for inputting the retrieving data composed of the

character string, the symbol string, the figure, or the image or the like;

an interactive graphics identification data selecting means for selecting one or plural interactive graphics identification data that are related with each other from the interactive graphics identification database means on the basis of the retrieving data inputted from this retrieving data input means;

an image importing means for importing the corresponding interactive graphics from the image input means on line on the basis of this selected interactive graphics identification data; and

a display means for displaying the interactive graphics that is imported by this image importing means.

[Claim 4]

The interactive graphics delivery system according to Claims 1, 2, or 3, wherein the image input means picks up images that are seen from the respective live spots toward plural directions, respectively; and

the interactive graphics identification data in order to identify the respective interactive graphics from each other is composed of position data for indicating a position of each live spot where the image input means is installed and directional data for showing a direction in which that image input means shots an image.

[Claim 5]

An interactive graphics delivery system, comprising:

an image input means that is provided at each live spot in order to constantly input interactive graphics on many live spots that can be disclosed to a public in real time, respectively;

an interactive graphics identification data recording means for recording interactive graphics identification data in order to identify the respective interactive graphics from each other;

a present position specifying means for specifying a present position of a user;

an interactive graphics identification data selecting means for selecting the interactive graphics identification data in order to specify the interactive graphics on one or plural live spots that are near the present position of the user;

an image importing means for importing the corresponding interactive graphics on the basis of this selected interactive graphics identification data; and

a display means for displaying the interactive graphics that is imported by this image importing means in real time.

[Claim 6]

The interactive graphics delivery system according to Claim 5,

wherein the image input means picks up images that are seen from the respective live spots toward plural directions, respectively; and

the interactive graphics identification data in order to identify the respective interactive graphics from each other is composed of position data for indicating a position of each live spot where the image input means is installed and directional data for showing a direction in which that image input means shots an image;

the present position specifying means includes a means for specifying the present position of the user and a means for specifying a progress direction of the user; and

the interactive graphics identification data selecting means selects the interactive graphics identification data that is composed of the position data showing a position of a live spot, which is located in a direction of the progressing side of the user from the present position of the user and is near the present position of the user, and the directional data showing the progressing side of the user on the basis of the present position of the user and the progress direction of the user that are specified by the present position specifying means.

[Claim 7]

The interactive graphics delivery system according to any one of Claims 1 to 6, further comprising:

a marking means for marking a portion that is designated by a user in the interactive graphics displayed by the display means in order to distinguish the portion from other portions.

[Claim 8]

The interactive graphics delivery system according to any one of Claims 1 to 7, further comprising:

a voice input means that is disposed in the vicinity of the image input means, for inputting a voice generated on a live spot where the image input means is disposed or on its periphery in real time; and

a voice output means that is disposed in the vicinity of the display means, for

outputting a voice from the voice input means.

[Claim 9]

The interactive graphics delivery system according to any one of Claims 1 to 8, further comprising:

an aroma input means that is disposed in the vicinity of the image input means and is composed of an aroma sensor and a means for converting a signal from this aroma sensor into digital data of an aroma, for inputting an aroma on a live spot where the image input means is disposed or on its periphery;

a converting means for converting the aroma data from the aroma input means into fragrance blending data for generating an aroma similar to that aroma; and

an aroma generating means that is disposed in the vicinity of the display means, for generating a desired aroma by blending the fragrance from the fragrance blending data.

[0001]

[Detailed Description of the Invention]

[Technical Field to which the Invention Belongs]

The present invention relates to a delivering interactive graphics system, which can deliver a real circumstance in real time of each spot while relating the interactive graphics to a map or the like. In addition, the present invention relates to a system for displaying a map including a spot of the interactive graphics from the interactive graphics.

[0002]

[Prior Art]

Conventionally, there has been a system for recording images at respective spots in a recording medium such as a CD-ROM or a hard disk, retrieving them on the basis of retrieving data such as a predetermined key word, and then, displaying them.

[0003]

[Problems that the Invention is to Solve]

However, these images recorded in the recording medium are “past images” (they are not “fresh images”). Therefore, this involves a problem such that a user only can see “old (not fresh)” images although a real scene is changing day by day depending on season’s transition, a weather of a day, and a condition of a construction work of a road and a building. In addition, assuming that the images recorded in the recording medium are just updated, these images do not respond to a user’s wish that the user wishes to see a

real condition of the present moment. Further, there is a problem such that it is very expensive to frequently update the image data with respect to the recording medium.

[0004]

The present invention has been made taking the foregoing problems into consideration and an object of which is to provide a delivering interactive graphics system, which can deliver a real circumstance on an arbitrary position through an image in real time to a user. In addition, according to the present invention, another object of the present invention is also to provide a system for displaying a map including a spot of the interactive graphics from the interactive graphics.

[0005]

[Means for Solving the Problems]

(Related Art)

As a related art that is identified by the present inventor, the followings are considered. They are identified by the present inventor when the present application (the application after an internal priority date under Patent Law Section 41) has been filed although it is not clear if they are “the prior arts” of the present invention (if it is publicly-known before a priority date (June 11, 1996)).

(a) According to “Weekly Diamond, additional volume 1996. 8 Internet Super Time Management” issued by Diamond Corporation, the following description is given, namely, “In Internet, there are many cases that a TV camera is fixed and simultaneous reporting of a sight spot is provided. In the future, you will be able to see a real image of world’s heritage such as Sphinx and a hill overlooking Himaraya and a sight spot such as the Arc de Triomphe in Paris” (in this document, P.76).

“How about putting a camera on a lobby or an entrance of a hotel, making the camera on-line, and seeing the hotel via a remote controller? A person will see that the hotel is crowded or happen to see his or her acquaintance there on the web. Such on-line camera is increasing on the web.” (in this document, P. 82)

As an introduction of a website of Internet, “A History Street <http://www.kiis.or/rekishi/> Keiko Hata, You can take a walk in Ise, Asuka, Nara, Kyoto, Osaka, and Kobe that are main scene spots of a history street according to captures and photos (not less than 100) (snip) You can access each item by means of retrieving by area and by age and selection via a mouse (a clickable map) on the map. At present, the information is given only

through the captures and the photos, however, (in the future) we are offering you a moving image and voice information” (in the document, P. 133).

(b) According to an article entitled as “Completely use a magic box and overturn a view of a world” in Nippon Keizai News Paper dated on June 16, 1996, the following is given in the article for introducing Mr. Masaki Fujihata, a computer artist. Namely, “Recently, he is immersed in a project using Internet together with students at Keio University where he is teaching. For example, he is trying to deliver an image of Mt. Fuji at 24 hours real time through a camera put in Shonan Fujisawa Campus. Worldwide access users can change a direction of the camera through their PC at home and can zoom in”.

(c) According to “Weekly Diamond” issued on August 31, 1996 by Diamond Corporation, on P. 84, the following is given in the article entitled “Diary of Super Filling, Virtual Tour of Map and Photo (written by Yukio Noguchi). Namely, “there is ‘a virtual tour’ in Internet. If you click a map appearing on a screen, the photo at this point will appear”.

(d) In an advertisement column of Nippon Keizai News Paper dated on September 3, 1996, there is a description entitled “Map Information System with a high operability Sumitomo Denko Systems”, and it says, “A digital road map exclusively for Windows 95, ‘AtlaMate/Windows 95 edition’, which has been developed and sold by Sumitomo Denko Systems (snip). This product allows a still image, a moving image, and a voice to be given on a map as a multimedia function.”

In addition, in the specification of “AtlaMate/Windows 95 edition” in this advertisement article, the following description is given. “Abundant Registration Function, It can register a still image such as a photo, a moving image such as a video, and a voice or the like on a map”

(e) According to an article entitled as “Completely Use Internet, Feel nature at home” in Nippon Keizai News Paper dated on September 30, 1996, the following is given. Namely, “in cooperation with NEC, Sakawa-machi in Kochi Prefecture opened ‘Sakawa Internet Broadcasting Station’ which allows a user to enjoy a natural scenery through Internet by a live broadcast. Setting a camera on a top of Mt. Kokuzo at this town (675 meters above sea level) and freely moving a camera from a PC at home or at office, the user can enjoy a scenery from Cape Asizuri to Cape Muroto. This broadcasting center was opened at Sakawa Jibasangyo center. Transmitting an image from a camera without a wire to a camera control apparatus of Nagano Chominkan, which is a facility established

by a town and is located at a base separated from the camera about 3 km, a still image is delivered on Internet. Freely remotely controlling the camera from a PC, the user can enjoy a panorama about 300 degrees in a horizontal direction and about 60 degrees in a vertical direction in a zoom of the maximum 10 times. An address of the Internet broadcasting center is <http://www.meshnet.or.jp/sakawa/>. NEC expands the Internet broadcasting center nationwide from May. NEC will open the Internet broadcasting center on Matsumae-cho, Bibae-cho, and Saroma-cho of Hokkaido and they are setting cameras on scene spots and beauty spots more than 100 within 2 to 3 years”.

As described above, there are various arts relating to the present invention. However, although any of them relates to the present invention, the present invention further develops these related arts and these related arts do not deny novelty of the present invention.

[0006]

In order to solve the problems of the above-mentioned conventional arts, a delivering interactive graphics system according to the present invention is as follows:

(1) The delivering interactive graphics system according to the present invention comprises an image input means that is provided at each live spot, for inputting interactive graphics on many live spots that can be disclosed to a public in real time, respectively; an interactive graphics identification database means for recording the interactive graphics identification data in order to identify the respective interactive graphics of the respective live spots from each other while relating and matching them to each point on the map of the map database, respectively; a retrieving means for retrieving the corresponding one or plural interactive graphics identification data from the interactive graphics identification database means on the basis of the spot that is designated on the map of the map database; an image importing means for importing the corresponding interactive graphics in real time with a wire or without a wire on the basis of the interactive graphics identification data that is retrieved by this retrieving means (for importing the corresponding interactive graphics according to a method for transmitting it through a network or accessing it by a browsing software for Internet and browsing it or the like); and a display means for outputting an interactive graphics that is imported by this image importing means (a moving image or a still image).

(2) In addition, the present invention may comprise an image input means that is provided

at each live spot in order to constantly input interactive graphics on many live spots that can be disclosed to a public in real time, respectively; an interactive graphics identification database means for recording a map database for recording a map and coordinate data for specifying respective spots on the map, the coordinate data in the map database, and the interactive graphics identification data for identifying the respective interactive graphics while relating and matching them each other; a retrieving means for retrieving one or plural spots on the map corresponding to or relating to the live spot of the interactive graphics from the interactive graphics identification database, when a certain interactive graphics is displayed, using interactive graphics identification data for identifying that interactive graphics as a key; a map data extracting means for extracting map data in order to indicate a map of a predetermined area including the spot on the map that is retrieved by this retrieving means; and a display means for outputting a map by means of map data that is extracted by this map data extracting means.

(3) Further, the delivering interactive graphics system according to the present invention comprises an image input means that is provided at each live spot in order to constantly input interactive graphics on many live spots that can be disclosed to a public in real time, respectively; an interactive graphics identification database means for recording interactive graphics identification data in order to identify the respective interactive graphics from each other while relating them with a key composed of a character string, a symbol string, a figure, or an image or the like; a key input means for inputting the key composed of the character string, the symbol string, the figure, or the image or the like; a retrieving means for retrieving the corresponding one or plural interactive graphics identification data from the interactive graphics identification database means on the basis of the key that is inputted from this key input means; an image importing means for importing the corresponding interactive graphics on the basis of the interactive graphics identification data that is retrieved by this retrieving means (including the case of browsing it by a browser for Internet when it is transmitted by a network); and a display means for outputting an interactive graphics (a moving image or a still image) that is imported by this image importing means.

(4) In addition, according to the present invention, the image input means may pick up images in plural directions from one live spot (for example, the case of picking up an image when one camera is pivoted to be located in certain plural directions or the case of

picking up an image at the same time providing plural video cameras in plural directions, respectively), and it is preferable that the interactive graphics identification data for specifying the respective interactive graphics is composed of the position data showing the positions of respective live spots where the image input means is disposed and the directional data showing the direction in which the image input means shots the image.

(5) In addition, the present invention comprises an image input means that is provided at each live spot in order to constantly input interactive graphics on many live spots that can be disclosed to a public in real time, respectively; an interactive graphics identification data recording means for recording interactive graphics identification data (composed of the coordinate data of the latitude data and the longitude data or the like) in order to identify the respective interactive graphics from each other; a present position specifying means (a conventional publicly-known GPS receiver and the like) for specifying a present position of a user; an interactive graphics identification data selecting means for selecting one or plural interactive graphics identification data corresponding or relating to one or plural live spots that are near the present position of the user on the basis of the present position of the user (composed of the coordinate data of the latitude data and the longitude data or the like) that is specified by this present position specifying means; an image importing means (including the case of accessing it and browsing it through a network and the case of transmitting it or the like) for importing the corresponding interactive graphics on line on the basis of this selected interactive graphics identification data; and a display means for displaying an interactive graphics (a moving image or a still image) that is imported by this image importing means in real time.

(6) In addition, according to the present invention, the image input means picks up images that are seen from the respective live spots toward plural directions, respectively, as same as the above-described (4); the interactive graphics identification data in order to identify the respective interactive graphics from each other is composed of position data for indicating a position of each live spot where the image input means is installed and directional data for showing a direction in which that image input means shots an image; the present position specifying means includes a means for specifying the present position of the user and a means for specifying a progress direction of the user; and the interactive graphics identification data selecting means selects the interactive graphics spot identification data in order to specify the interactive graphics (a moving image or a still

image), which is located in a direction of the progressing side of the user from the present position of the user and is near the present position of the user, and copies a direction near the progress direction of the user on the basis of the data showing the present position of the user that is specified by the present position specifying means (the position coordinate data composed of the latitude data and the longitude data or the like) and the data showing the progress direction of the user that are specified by the present position specifying means.

(7) In addition, according to the present invention, it is preferable that a marking means for marking a portion that is designated by a user in the interactive graphics (a moving image or a still image) displayed by the display means in order to distinguish this portion from other portions.

(8) In addition, according to the present invention, it is preferable that the image input means may also comprise a means for inputting a voice that is generated on that spot in real time.

(9) In addition, the present invention may further comprise an aroma input means that is provided in the vicinity of the image input means and is configured by an aroma sensor and a means for converting a signal from this aroma sensor into aroma digital data, for inputting an aroma on the spot where the image input means is disposed or an aroma around the spot; a converting means for converting the aroma data from this aroma input means into fragrance blending data for generating an aroma similar to that aroma; and an aroma generating means that is disposed in the vicinity of the display means, for generating a desired aroma by the fragrance blending data. Further, in this (9), the above-described “converting means for converting the aroma data into the fragrance blending data for generating an aroma similar to that aroma” is directly connected to the aroma input means. This converting means may be connected to the aroma generating means via the computer communication network or may be directly connected to the aroma generating means via the input means and the computer communication network .[0007]

[Mode for Carrying Out the Invention]

First Embodiment:

Next, with reference to Figs. 1 to 4, the first embodiment according to the present invention will be described. In Fig. 1, a reference numeral 1 denotes a personal

computer (PC) used by a user and the personal computer 1 is configured by a control apparatus 2 made of a CPU and a communication modem or the like; a hard disk apparatus 3 in which a computer program and data are recorded, a CD-ROM drive 5 for driving a CD-ROM 4 in which the computer program and the data are recorded; a key board 6 and a mouse 6a for inputting the data; a display 7 for outputting an image; and a speaker 8 for outputting a voice.

[0008]

The control apparatus 2 is connected to a computer for a relay service 11 via a public circuit for a computer communication network 10 such as Internet. To this computer for a relay service 11, computers (servers) 14, 14a, and 14b are connected, which serve to control video cameras 12, 12a, and 12b and sound collecting microphones 13, 13a, and 13b, which are disposed on many live spots respectively, for recording the data from these video cameras 12 and sound collecting microphones 13, and allowing the user to browse the data via a communication network. The image data and the voice data inputted by these many video cameras 12 and microphones 13 or the like can be transmitted to the user via the computers 14 and the computer for a relay service 11 according to need from the user. Further, four video cameras 12 are installed on respective live spots, respectively, and these four video cameras are preferably installed so as to shoot the images in four directions including east, west, south, and north, respectively.

[0009]

In addition, the computer for a relay service 11 is also connected to many other computers for a relay service 12. For example, the user connected to a certain computer for a relay service 11 can import the inputted data from other computer for a relay service 12 or the like via this computer for a relay service 11 and from the video camera and the microphone via the computer (the server) connected to the computer 11. In this case, as a method for importing an image and a voice, various methods are available such as a method for adding the information from the video camera and the microphone to an electronic mail and a method for importing a website by a browser software for Internet by the user, which website is opened on a computer communication network so as to deliver the input information of the video camera and the microphone (namely, a method for using a website on a computer communication network like a hard disk of a personal computer

at the user side) or the like.

[0010]

According to this first embodiment, in the CD-ROM 4, a map database for recording the map data and the address data for specifying each spot on this map relating them with each other; an interactive graphics database for recording this address data with the image identification data for identifying the interactive graphics of respective live spots (respective places where the video camera 12 and the microphone 13 are installed) relating and corresponding them with each other; a reproduction program for reproducing these map databases; a retrieving program for retrieving the interactive graphics database; and a program for importing the interactive graphics corresponding to the retrieved interactive graphics identification data from this retrieved interactive graphics identification data and displaying it are recorded.

[0011]

It is assumed that a user who lives in Osaka now wishes to see a sunset in the coastline of Shonan beach, in Kanagawa Prefecture that is his or her home town, in summer. In this case, for example, it is assumed that the user reproduces the map database to display the map of a predetermined area including Shonan beach on a screen and then, the user clicks the spot of Shonan beach on this screen by means of the mouse 6a. Then, on the basis of this input, the control apparatus 2 will retrieve the address data corresponding to the spot on this map from the spot database. After that, on the basis of this retrieved address data, the control apparatus 2 will retrieve the interactive graphics identification data indicating the interactive graphics of the corresponding live spot from the interactive graphics database. Then, on the basis of this retrieved interactive graphics identification data, accessing the computer for a relay service 11 and importing the image data and the voice data from the video camera and the microphone installed on the live spot corresponding to the interactive graphics identification data (the video camera and the microphone installed in a direction corresponding to an image pickup direction when the interactive graphics identification data also specifies the image pickup direction) on line, they are outputted from the display 7 and the speaker 8 in real time. The image and the voice to be outputted in this case are the image and the voice in real time of the present time, so that the user can get feeling and impression as if the user is actually present at this spot. Conventionally, for example, there has been a CD-ROM capable of recording the

image of a beach, for example, Shonan beach, retrieving it from a key word and outputting it, and the images recorded in these CD-ROM are shot by a professional cameraman on the best time (for example, a time when a sunset is most beautiful) from the best angle. On the contrary, the image given in this embodiment may be shot on a rainy day or a cloudy day or on a time when you cannot see the best scenery. However, since this image is “the image at this moment and at this instance (namely, the image that is never seen), the user can feel “realistic sensation” and “impression”. In other words, when the user “wishes to see a sunset of Shonan beach now”, unless he or she can see not the past recorded image of “sunset on Shonan beach” but the image of “sunset on Shonan beach at this moment”, the user cannot get a strong impression. This embodiment can meet this user’s wish.

[0012]

Further, the constitution of the embodiment that has been explained with reference to Fig. 1 will be explained again with reference to Fig. 2. Fig. 2 illustrates the constitution of the embodiment functionally and conceptually. In Fig. 2, a reference numeral 32 denotes an interactive graphics input unit constituted of a video camera and a microphone for inputting an interactive graphics and a voice of each spot in real time, which is connected to a computer communication network (a computer communication network) 30. A reference numeral 24 denotes a CD-ROM, in which the map database 26, its reproduction program and its retrieving program; the interactive graphics identification database 25 and its retrieving program; and a program for importing the corresponding interactive graphics from the interactive graphics identification data via the communication network or the like are recorded. In addition, in Fig. 2, a reference numeral 21 denotes a map database reproducing unit for reproducing the map database 26 which is recorded in the CD-ROM 24; and a reference numeral 22 denotes a control unit for controlling a display unit 27 and a speaker 28 upon receipt of a signal from this map database reproducing unit 21 and outputting predetermined image and voice. In addition, a reference numeral 23 denotes a retrieving unit for retrieving the identification data of the corresponding interactive graphics from the interactive graphics identification database 25 on the basis of the address data on the spot which is designated by the user (click it by a mouse) on the screen on which the map database is reproduced. Controlling an image importing unit (for example, an apparatus for recording a browser which is a software for

viewing a website of Internet and executing it) 26 and accessing an image input unit 32 via a communication circuit for a computer communication network 30, the control unit 22 may import the interactive graphics and the voice from the image input unit 32 in real time on line. The control unit 22 may output these interactive graphics and voice that are imported on line by means of the display unit 27 and the speaker 28 in real time while relating them with the reproduced image (the map image) from the map database 26.
[0013]

Next, a screen to be displayed by the display 7 being controlled by the control apparatus 2 shown in Fig. 1 will be described with reference to Fig. 3 and Fig. 4. As shown in Fig. 3, on an upper half part 7a of the display 7, the interactive graphics is displayed and on a lower half part 7b thereof, the map is displayed. When using this first embodiment, at first, driving the CD-ROM 4 shown in Fig. 1, the user may display a desired map on the lower half part 7b of the display 7 from the map database. For example, by retrieving the map data from a key word such as a name of a place, the map in the map database recorded in the CD-ROM 4 may be displayed (such an art has been publicly known). Then, according to the present embodiment, for example, as shown in a, b, c, d, e, f, and g of Fig. 4, points showing each spot are colored in a predetermined color (for example, red) to be displayed on this displayed map. Among respective points of a, b, c, d, e, f, and g of Fig. 4, a, b, c and e of Fig. 4 are corresponding to the video camera 12 and the microphone 13 in Fig. 1. In other words, according to the first embodiment, the video camera 12 in Fig. 1 is configured by four video cameras that are installed on the positions of a, b, c, and d so as to pick up images in different directions, respectively. In addition, the microphone 13 in Fig. 1 is configured by four microphones that are installed so as to collect sounds in different directions, respectively. In other words, explaining the video camera 12, among four video cameras configuring the video camera 12, the video camera installed on the position a in Fig. 4 picks up an image in West (a left direction) in the figure so as to generate an interactive graphics having the image identification data of "1428A". In addition, the video camera installed on the position b in Fig. 4 picks up an image in South (a lower direction) in the figure so as to generate an interactive graphics having the image identification data of "1428B". In addition, the video camera installed on the position c in Fig. 4 picks up an image in East (a right direction) in the figure so as to generate an interactive graphics having the image

identification data of “1428C”. In addition, the video camera installed on the position d in Fig. 4 picks up an image in North (an upper direction) in the figure so as to generate an interactive graphics having the image identification data of “1428D”. In addition, among respective points represented by a, b, c, d, e, f, and g of Fig. 4, e, f, and g of Fig. 4 are corresponding to the video camera 12a and the microphone 13a in Fig. 1. In other words, according to the first embodiment, the video camera 12a in Fig. 1 is configured by three video cameras that are installed on the positions of e, f, and g in Fig. 4 so as to pick up images in different directions, respectively. In addition, the microphone 13a in Fig. 1 is configured by three microphones that are installed so as to collect sounds in different directions, respectively. In other words, with respect to the video camera 12a, among three video cameras configuring the video camera 12a, the video camera installed on the position e in Fig. 4 picks up an image in North-West (a left upper direction) in the figure so as to generate an interactive graphics having the image identification data of “1429A”. In addition, the video camera installed on the position f in Fig. 4 picks up an image in East-South (a right lower direction) in the figure so as to generate an interactive graphics having the image identification data of “1429B”. In addition, the video camera installed on the position g in Fig. 4 picks up an image in East (a right direction) in the figure so as to generate an interactive graphics having the image identification data of “1429C”. As described above, according to the embodiment to be explained with reference to Fig. 4, a combination of the address data for identifying each spot on the map (“1428” and “1429” or the like) and the data (“A” “B” “C” “D” or the like) showing the image pickup direction of each video camera on the same live spot and the interactive graphics identification data for identifying the interactive graphics on each spot (“1428A” and “1429A” or the like) are recorded while relating them with each other. More specifically, according to the example shown in Fig. 4, four interactive graphics identification data indicating four pickup image directions, namely, “1428A”, “1428B”, “1428C” and “1428D”, respectively, are recorded corresponding to one address data “1428” on the map (the address data for identifying the area of a center cross point in Fig. 4). In addition, three interactive graphics identification data indicating three pickup image directions, namely, “1429A”, “1429B”, and “1429C”, respectively, are recorded corresponding to one address data “1429” on the map (the address data for identifying the area of a left point in Fig. 4). Further, according to the example shown in Fig. 4, the interactive graphics identification

data (for example, "1428A") is configured by a combination of the address data (for example, "1428") on the map and the directional data (for example, "A"), however, according to the present invention, it is not always necessary to use the address data on the map in the interactive graphics identification data as it is. For example, making the address data on the map into the address data (or the coordinate data) configured by equally spacing the entire map, the interactive graphics identification data may be configured by a combination of the identification code (for example, a serial number of the order of setting of the video camera) on a certain spot where the video camera is installed in practice and the directional data.

[0014]

According to the example shown in Fig. 4, the identification data of the interactive graphics that is obtained when each video camera 12 and each microphone 13 input an image and a voice, respectively (here, a term of "an interactive graphics" is used as a meaning including both of the image data inputted by the video camera and the voice data inputted by the microphone in principle) is configured by the data indicating the spot and a direction in which the video camera 12 is shooting an image (this direction is identical with a direction in which the microphone 13 tries to collect a sound). In other words, the interactive graphics are identified by each spot and its image pickup direction each other and "the interactive graphics identification data" is configured by the data indicating each spot and the data indicating a direction of image pickup and sound collection. Therefore, even on the same spot, if the direction of shooting an image (a direction such as East, West, South, and North or the like) is different, it becomes a different interactive graphics having different identification data. Explaining this with reference to Fig. 4, a spot having the address data (1428A) represented by "a" in Fig. 4 corresponds to the interactive graphics having the image identification data, namely, (1428A), and the interactive graphics indicating this identification data, namely, (1428A) is an image made by shooting the scenery in an A direction (a left direction in the figure) from the spot of "a" in Fig. 4. In addition, the spot on the map having the address data (1428B) represented by "b" in Fig. 4 corresponds to the interactive graphics having the identification data, namely, (1428B), and the interactive graphics indicating this identification data named as (1428B) is an image made by shooting the scenery in a B direction (a lower direction in the figure) from the spot of "b" in Fig. 3. In addition, the

spot on the map having the address data (1428C) represented by “c” in Fig. 4 corresponds to the interactive graphics having the identification data, namely, (1428C), and the interactive graphics indicating this identification data named as (1428C) is an image made by shooting the scenery in a C direction (a right direction in the figure) from the spot of “c” in Fig. 4. In addition, a spot represented by “d” in Fig. 4 having the address data named as (1428D) corresponds to the interactive graphics having the identification data named as (1428D) one-on-one, and the interactive graphics indicating this identification data named as (1428D) is an image made by shooting the scenery in a D direction (an upper direction in the figure) from the spot of “d” in Fig. 4. Further, in Fig. 4, the spot represented by “e” having the address data (1429A) corresponds to the interactive graphics having the identification data, and the interactive graphics indicating this identification data named as (1429A) is an image made by shooting the scenery in an A direction (a left upper direction in the figure) from the spot of “e” in Fig. 4. In addition, in Fig. 4, the spot represented by “f” having the address data (1429B) corresponds to the interactive graphics having the identification data, and the interactive graphics indicating this identification data named as (1429B) is an image made by shooting the scenery in a B direction (a right lower direction in the figure) from the spot of “f” in Fig. 4. In addition, in Fig. 4, the spot represented by “g” having the address data (1429C) corresponds to the interactive graphics having the identification data, and the interactive graphics indicating this identification data named as (1429C) is an image made by shooting the scenery in a C direction (a right direction in the figure) from the spot of “g” in Fig. 4.

[0015]

As seen from the above description, according to the example shown in Fig. 4, a reference numeral 1428 denotes the address data on the map indicating the area of this cross point (in this example shown in Fig. 4, the area of this cross point is referred to as “a live spot”), and A, B, C, and D indicate a direction of shooting an image (and collecting a sound) from the cross point area (the live spot). Likewise, according to the example in Fig. 4, a reference numeral 1429 denotes the address data on the map indicating the cross point area on the left on the map, and A, B, and C indicate a direction of shooting an image (and collecting sound) from the cross point area. According to the example shown in Fig. 4, the identification data of the interactive graphics is configured by a combination of the address data (“1428” and “1429” or the like) indicating a position of each live spot

on the map and the data indicating the direction (A, B, C, and D or the like).

[0016]

Accordingly, if the user wishes to visit the place, for example, the area of the cross point indicated by 1428 in Fig. 4 and he or she “wishes to know the condition of this cross point now (crowded or not, what person is walking in what clothes or the like) and in order to know this, wishes to see the interactive graphics”, the user may click any spot among a to d on the map shown in Fig. 4 by means of a pointing device such as a mouse. Then, the interactive graphics identification data corresponding to the address data on the map is retrieved by means of the control apparatus 2 (from the interactive graphics database), and on the basis of this retrieved interactive graphics identification data, the corresponding interactive graphics is imported via the computer communication network to be displayed on the upper half part 7a of the display 7.

[0017]

In addition, obtaining a road between the place where the user wishes to visit and the place where the user is present now on the map (this has been realized conventionally by a public-known art), the user also may indicate the interactive graphics on the spot on its route by rotation (for example, assuming that a display time of one interactive graphics to be five seconds, a next interactive graphics will be displayed by rotation for each five seconds). In addition, when the user is driving a car, obtaining the present position information on the map from the positioning information received by a GPS receiver and obtained from various sensors (this has been realized conventionally by a public-known art) and obtaining the identification data of the interactive graphics from the spot corresponding to the present position of himself or herself obtained on the map, the user also may import the corresponding interactive graphics through a server on the network on the basis of the identification data (for example, the computer for a relay service 11 shown in Fig. 1) and may display it. Thereby, the user can check if the present position on the map (the present position that is presumed by the GPS receiver or depending on the information from a sensor) is identical with the real present position or not with eyes. In other words, if the interactive graphics displayed on the display 7 is identical with the real scenery obtained when the user sees the outside from the inside of a car on the basis of the interactive graphics identification data that is obtained as described above, it can be said that there is no measurement error and the present position presumed by the GPS is correct.

However, if they are not identical, the presumed present position is not correct.

[0018]

Further, the control apparatus 2 may be connected to the computer for a relay service 11 without a wire, the computer for a relay service 11 may be connected to each video camera 12 and each microphone 13 without a wire, and “the map database”, “the interactive graphics database”, these retrieving programs, and map database reproduction programs may be imported from the server (the computer) on the network such as the computer for a relay service 11 or the like without being read from the CD-ROM 4. Particularly, as described above, in the case of using the personal computer 1 shown in Fig. 1 in a moving car (when the user himself or herself is driving a car, in the case of obtaining the present position information on the map displayed on the screen from the positioning information received by a GPS receiver and obtained from various sensors and displaying this “an interactive graphics on the live spot corresponding to the present position of the user himself or herself and in an image pickup direction corresponding to a progress direction of the user himself or herself” on the display 7 of the personal computer 1), it is necessary to transmit or receive the data between the control apparatus 2 of the personal computer 1 and the computer for a relay service without a wire.

[0019]

Second Embodiment:

Next, with reference to Fig. 1, the second embodiment according to the present invention will be described. In Fig. 1, a reference numeral 1 denotes a personal computer (PC) used by a user and the personal computer 1 is configured by a control apparatus 2 made of a CPU and a communication modem or the like; a hard disk apparatus 3 in which a computer program and data are recorded, a CD-ROM drive 5 for driving a CD-ROM 4 in which the computer program and the data are recorded; a keyboard 6 for inputting the data; a display 7 for outputting an image; and a speaker 8 for outputting a voice. The control apparatus 2 is connected to a computer for a relay service 11 via a public circuit 10. To this computer for a relay service 11, video cameras 12 and sound collecting microphones 13 are connected via a computer (server) 14. The image data and the voice data inputted by these many video cameras 12 and microphones 13 or the like can be transmitted to the user via the computers 14 and the computer for a relay service 11 according to need from the user. In addition, many video cameras 12 and

sound collecting microphones 13 can be identified each other depending on the identification data. Accordingly, further, the interactive graphics and the voice from respective cameras 12 and respective sound collecting microphones 13 can be identified with each other. In addition, the image data and the voice data inputted from these many video cameras 12 and microphones 13 or the like can be browsed by the user via the computer for a relay service 11 on line (for example, the user can browse these data by using a browser of a software for viewing a website of Internet). In addition, the computer for a relay service 11 is also connected to many other computers for a relay service 12 or the like. For example, the user connected to the computer for a relay service can import the data, which are inputted from the video camera and the microphone connected to other computers for a relay service 12 or the like, from other computers for a relay service 12 or the like via the computer for a relay service 11.

[0020]

According to the second embodiment, in the CD-ROM 4, an interactive graphics database relating the image identification data for identifying the interactive graphics of respective spots (respective places where the video camera 12 and the microphone 13 are installed) with many key words each other; and a program for retrieving the image identification data from these key words are recorded. The key word recorded in this interactive graphics database may include various things, for example, a name of a place, a category of a place (beach, street corner, harbor town, mountain, intersection, building, restaurant, stage theater, theater, sport facility, baseball field, hot spring, and temple or the like), a category of action (sport, play, cinema, eating, and walk or the like). It is assumed that a user who lives in Osaka now wishes to see a sunset in summer, at Shonan beach, on a coastline, in Kanagawa Prefecture that is his or her home town. In this case, for example, if the user inputs key words such as "Kanagawa Prefecture, Summer, Shonan-beach, Coastline, Sunset" or the like, on the basis of these inputted key words, the control apparatus 2 will retrieve the corresponding interactive graphics identification data from among the interactive graphics identification data recorded in the CD-ROM 4. Then, on the basis of this retrieved interactive graphics identification data, accessing to the computer for a relay service 11 and importing the image data and the voice data from the video camera and the microphone that are installed on the spot corresponding to this identification data in real time, the user can output them from the display 7 and the

speaker 8. The image and the voice to be outputted in this case are the image and the voice in real time of the present time, so that the user can get feeling and impression as if the user is actually present at the spot.

[0021]

In addition, in the same way, according to the second embodiment, if the user inputs key words such as “temple, Kyoto”, the control apparatus 2 will retrieve a plurality of image identification data corresponding to these key words and will display them on the display 7 by rotation. In addition, for example, if the user in a long-term hospitalization wishes to visit hot springs of each spot in Kyushu, although he or she cannot visit in practice, if the user inputs key words such as “each place of Kyushu, visit hot springs”, retrieving a plurality of image identification data corresponding to these key words and receiving the image corresponding to these identification data in practice, then, the control apparatus 2 will display them on the display 7 by rotation. This allows the user to be capable of getting the impression as same as when he or she visits there in practice although he or she does not visit there. Thus, it can be also said that this second embodiment is a system which can realize “a virtual travel”, whereby the user can get the impression as same as when he or she visits there in practice although he or she actually does not visit there.

[0022]

Likewise, if the user wishes to try out the food at various restaurants at a harbor town in Yokohama, inputting key words of “Yokohama, a harbor town, and trying out the food at various restaurants”, the control apparatus 2 will retrieve the corresponding plural image identification data on the basis of these key words and will import the data of the interactive graphics from plural respective spots corresponding the these key words (in this case, if the setting the video camera and the microphone in the restaurant is allowed to offer the image to the public, the user can know the status of the inside of the restaurant, for example, a level of congestion of customers and an atmosphere of a restaurant or the like). In addition, in the same way, if the user wishes to visit stage theaters (baseball fields) throughout Japan, inputting key words of “Japan, visiting stage theaters (baseball fields)”, the control apparatus 2 will retrieve the corresponding image identification data on the basis of these key words, and then, the control apparatus 2 will output the interactive graphics corresponding to these key words in real time. In this case, if each

stage theater or each baseball field accepts transmission of the content of a play (or the content of a match) only for a predetermined time, the user can watch the content of this play (or the match) as if in place of an index even only for a predetermined time.

[0023]

Third Embodiment:

Next, the third embodiment according to the present invention will be described. The third embodiment is provided with the followings in addition to the constitution of the above-described first embodiment. At first, an aroma input apparatus is provided in the vicinity of the video camera 12 and the microphone 13. This aroma input apparatus is provided with an aroma sensor and a coding unit for coding a signal from this aroma sensor into digital data. The aroma sensor is configured by the existing plural aroma sensors and all of the aroma amount detection values from respective sensors are provided to the coding unit (an encoder). The coding unit (the encoder) may code the provided aroma amount detection value. This coded aroma data (the digital data) is recorded in a recording apparatus, and then, a remote user can browse and import the data in real time via the computer communication network. Further, it is preferable that a plurality of the aroma sensors is prepared for each kind of aroma so that the information which can reproduce the original aroma of the field site faithfully can be obtained. Next, on the user side is provided a converter for converting the browsed and imported aroma data (the digital data) into fragrance blending data in order to generate the aroma which is similar to the aroma of the field site and an aroma generator, which is disposed in the vicinity of the display 7 (Fig. 1), for blending a fragrance from the fragrance blending data and generating a desired aroma. At first, the above-described "a converter for converting the browsed and imported aroma data (the digital data) into fragrance blending data for generating an aroma similar to the aroma of a field site" will be described below. The converter may convert a pattern of the detection value of each aroma sensor into a pattern of the output value of each fragrance. More specifically, with respect to each of various kinds of aromas, when the user allows the aroma sensor to detect the aroma, the value of the detection value has been searched and recorded in advance. Then, from the data recording a relation between this aroma and the detection value pattern of the aroma sensor and the data recording relation between each aroma and a (component) of fragrance, a pattern of a detection value of each aroma sensor and a pattern of an output value of

plural kinds of fragrances are recorded being related with each other. The converter may convert the pattern of the output value of the (component) of the fragrance (this becomes “the fragrance blending data”). Explanation thereof in more detail is as follows. In the converter, a sensor fragrance amount conversion table in which a relation between the detection value of the aroma sensor when each aroma is detected by the aroma sensor and the output value of each fragrance when this aroma is generated by the aroma generator to be described later has been recorded in advance. Then, the converter may convert the detection value for each aroma sensor into the output value for each fragrance with reference to this sensor fragrance amount conversion table on the basis of the detection value data of the aroma sensor.

[0024]

Next, the “aroma generator for generating a desired aroma by blending a fragrance from the fragrance blending data” will be described below. Preparing plural kinds of fragrances in advance, on the basis of the “fragrance blending data” (the above-described fragrance output pattern data, namely, the data indicating how much the aroma component is generated from each fragrance), the aroma generator may generate required kinds of aroma components (the component from the fragrance) by a required amount. As a configuration of the aroma generator, a stationary type for spreading the aroma in the entire space in a certain space and an individual portable type for allowing a person who wears the aroma generator near a user’s nose or in a user’s nose only to sense the aroma are considered. For example, as the stationary type, the followings are considered. In other words, aligning containers in which fragrances are contained on a bottom of a box and attaching a cover which can arbitrarily adjust an area where a fragrance contacts air to each container, an air blower is installed on the rear side of the box if needed. Then, in accordance with the data of the above-described “fragrance output pattern”, a degree of opening and closing of the cover of the container of each corresponding fragrance is adjusted. In addition, with respect to the portable type, the basic configuration may be the same as that of the stationary type, however, downsizing the basic configuration of the stationary type, the portable type can be attached in the vicinity of a nose of the user by a head supporter such as a headpiece type, a head set type, an eyeglass type, and a mask type or the like. Further, according to this third embodiment, the side of the personal computer 1 is provided with the above-described

“converter for converting the coded aroma data which is browsed and imported into the fragrance blending data for generating the aroma similar to the aroma of the field site”, however, the present invention is not limited to this. For example, the converter may be disposed on the spot where the video camera 12 and the microphone 13 on the field site are installed and the apparatus may be disposed in the computer (server) for a relay service 11 on the computer network. In addition, the art of “having data, recording, establishing a communication, and reproducing of an aroma” that has been described according to the above-described third embodiment is a prior art disclosed, for example, in Japanese Patent-Application Laid-Open No. 7-55742 or the like.

[0025]

Forth Embodiment:

Figure 5 is a block diagram showing a fourth embodiment of the present invention. In Fig. 5, a reference numeral 21 denotes a liquid crystal display (LCD). In addition, in Fig. 5, a reference numeral 22 denotes a Global Positioning System (GPS) receiver that has been conventionally put on the market, which measures a delay time of an electric wave from an artificial earth satellite and obtains the present position of the user depending on a distance from an orbit. This GPS receiver 22 may include a GPS receiving antenna for receiving a GPS electric wave to be transmitted from the artificial earth satellite and a position identifying unit (configured by a CPU) for identifying the present position from this GPS electric wave as latitude data and longitudinal data. The GPS antenna may receive an electric wave from the GPS satellite, for example, 1.5 GHz and may transmit the signal thereof to the position identifying unit. The position identifying unit may receive electric waves of four or more satellites which can receive the electric wave among the GPS satellites in operation, obtain the present position at a receiving point and calculate the latitude data and the longitude data on the basis of a distance between each satellite and the receiving point which is calculated from the known position of the satellite and the received electric wave. Further, the detailed constitution and the using method of the above-described GPS receiver 2 has been conventionally publicly-known (for example, refer to JP-A-5-45171, JP-A-7-30654, and JP-A-8-94735 or the like), so that the detailed description is herein omitted. In addition, in Fig. 5, a reference numeral 26 denotes a progress direction input unit for measuring the progress direction (East, West, South, and North or the like) when the user is traveling on foot, by a

vehicle, and by a railroad or the like, using an earth magnetism or the like and obtaining the progress direction. According to this forth embodiment, "the present position specifying means" of the user according to the present invention is configured by the GPS receiver 22 and the progress direction input unit 26. In addition, in Fig. 5, a reference numeral 23 denotes a control unit for receiving the coordinate data (the latitude data and the longitude data) as the present position information from the GPS receiver 22 and the data in the progress direction from the progress direction input unit 26, selecting the corresponding satellite image, and displaying it on the LCD 21. This control unit is configured by a personal computer or the like.

[0026]

In addition, in Fig. 5, a reference numeral 24 denotes a server (computer) for a map database that is connected to the control unit 23 via a public circuit network for a computer communication 20 such as Internet. This server (computer) for a map database 24 may record, for example, a map of all over Japan as a data base while relating it to the position identification data such as coordinate data (the latitude data and the longitude data), a name of a place, a name of a facility, and identification data of the facility (a telephone number of the facility) or the like. This server for a map database 24 is connected to the control unit 23 via the public circuit network 20 on line. Further, it is desirable that this public circuit network 20 may include not only a wire communication network but also a wireless communication network such as a portable telephone network, a personal handy phone system (PHS) network, an automobile telephone network and an artificial earth satellite communication network or the like.

[0027]

In addition, in Fig. 5, a reference numeral 25 denotes an interactive graphics input unit that is connected to the public circuit network for a computer communication 20 such as Internet and this interactive graphics input unit 20 is configured by a plurality of digital video cameras disposed on each live spot for inputting the interactive graphics in plural directions on each live spot (the interactive graphics seen in plural directions from respective live spot), respectively, on a steady basis, and a computer for providing an interactive graphics for providing the digital image data from these digital video cameras to a plurality of users who are accessing on line via a computer communication network such as Internet. This computer for providing an interactive graphics may record the

interactive graphics at respective spots as a data base as being related to the position identification data such as the coordinate data (the latitude data and the longitudinal data), a name of a place, a name of a facility, and the identification data of the facility (a telephone number of the facility or the like) and the directional data such as East, West, South, and North or the like. This computer for providing an interactive graphics is connected to the control unit 3 by the communication network 20 on line. Further, it is desired that this communication network 20 may include not only a wire communication network but also a wireless communication network such as a portable telephone network, a personal handy phone system (PHS) network, an automobile telephone network and an artificial earth satellite communication network or the like.

[0028]

The control unit 23 may access to the server for a map database 24 based on an instruction by means of an input apparatus such as the key board 26 or the mouse 27 and the like by the user and may import the data of a map on a predetermined area including a spot (a spot indicated by the input apparatus) desired by the user so as to display this data on the LCD 21. In addition, when the user indicates an arbitrary spot of the displayed map by means of the mouse 27 and directs a display of the interactive graphics of a predetermined area including this spot, the control unit 23 may access to the interactive graphics identification database 25 including the computer for providing an interactive graphics of respective live spots and may import the data of the interactive graphics of the corresponding predetermined area on line so as to display this interactive graphics on the LCD 21 in real time. In addition, when the user desires the display of the corresponding interactive graphics or the map including this live spot by inputting the name of the place, the name of the facility, and the identification data of the facility that the user desires to display, the control unit 23 may access to the interactive graphics identification database 25 or the server for a map database 24 and may import the corresponding interactive graphics and the corresponding map on line so as to display them on the LCD 21. In addition, when the user instructs to display an interactive graphics on the live spot in a direction toward a progress direction from the present point where the user himself or herself is located and located nearest and which is seen in its progress direction, the control unit 23 may receive the user's present position and the progress direction as the coordinate data (the latitude data and the longitudinal data) from the GPS receiver 22 and

the progress direction input unit 26 and the directional data. Then, on the basis of this coordinate data and this directional data, the control unit 23 may access to the interactive graphics identification database 25 of the corresponding respective interactive graphics and may be provided with the corresponding interactive graphics on line so as to display it on the LCD 21. Further, in this case, as a method whereby the control unit 23 receives the corresponding interactive graphics from the image input apparatus 25, various methods may be available, for example, a method for directly accessing to each of the image input apparatuses 25 of respective places by a browsing software for a conventional Internet and a method for demanding the image input apparatus 25 to transmit the corresponding interactive graphics data as a file attached to an electronic mail and receiving the transmission or the like.

[0029]

In addition, according to this fourth embodiment, in the case that a certain interactive graphics is displayed on the LCD 21, when the user orders to make a predetermined marking only a certain portion in the displayed interactive graphics, for example, only a specific building, a specific bridge, and a specific road, so that this portion can be easily distinguished from other portions, the control unit 23 may include a means (a program) which can mark that portion so as to be highlighted from other portions. As marking in this case, various methods, for example, a method for dyeing the portion by a different color and coloring it, a method for hatching only this portion, and a method for displaying that portion by a solid line that is thicker than other portion or the like are available.

[0030]

Fifth Embodiment:

Next, Figure 6 is a block diagram showing a fifth embodiment of the present invention. In Fig. 6, since reference numerals 21, 22, 23, 26, and 27 are the same as those in Fig. 4, the explanations thereof are herein omitted. In Fig. 6, a reference numeral 34 denotes a CD-ROM player (a reproducer) that is connected to the control apparatus 23, and a reference numeral 35 denotes a CD-ROM to be read by the CD-ROM player 34. In the CD-ROM 35, for example, the map database having the map of the entire Japan recorded in connection with the position identification data such as coordinate data (the latitude data and the longitude data), a name of a place, a name of a facility, and

facility identification data or the like is recorded. In addition, in Fig. 6, a reference numeral 31 denotes an image input apparatus that is connected to the computer communication network 30 such as Internet and the image input apparatus 31 is the same as the image input apparatus 25. The control unit 3 is capable of reading a map of a predetermined area including a position that is desired by the user and displaying it on the LCD 1 by reading the CD-ROM 15 by means of the CD-ROM player 14. In addition, the control unit 3 can import an interactive graphics in a predetermined direction that is desired by the user from a live spot that is desired by the user and can display it on the LCD 21 by accessing an image input apparatus 31 via the computer communication network 30. In addition, when the user commands to “display an interactive graphics on the live spot in a direction toward a progress direction from the present point where the user himself or herself is located and located nearest and which is shot from that spot toward a progress direction of the user himself or herself”, the control unit 23 may receive the user’s present position as the coordinate data (the latitude data and the longitudinal data) from the GPS receiver 22 and may receive the data in the progress direction of the user from the progress direction input unit 26. Then, on the basis of this coordinate data and the progress directional data, by accessing the image input apparatus 31, the control unit 23 may read the data of the interactive graphics at a live spot near the corresponding coordinate data and in a direction near the progress direction of the user on line so as to display this interactive graphics on the LCD 21 in real time.

[0031]

[Advantage of the Invention]

- (1) According to the interactive graphics delivery system of the present invention, the user can see the status of the spot at the present time in an interactive graphics, for example, only by designating the desired spot by means of a pointing device (for example, by clicking with a mouse) while watching a map. In addition, the user can display the interactive graphics corresponding to the desired spot continuously by means of the computer without designation by the pointing device each time if the spot identification data of plural spots of which interactive graphics the user desires to display are set to be inputted in series by a computer program. Therefore, here, the user can also experience “a virtual trip” to obtain the same impression as that when the user visits there although he or she does not actually

visit there while watching the map. In addition, for example, the user can compete with others on “a hunt for treasure” game in the world of the computer communication network in the world at the same time. The content of this game is that the users across the globe are searching one treasure while watching the interactive graphics of each spot in the world from the map of the entire world. In addition, by combining the conventional GPS receiver with the invention of Claim 1, the following effects can be obtained. Namely, if the user commands to read out the map of a predetermined area including the present position from the map database on the basis of the present position obtained from the GPS receiver (the coordinate data of the latitude data and the longitude data), display it, and import the interactive graphics of that spot on line by clicking the present position (the coordinate data) indicated on that displayed map or the spot near it, it can be checked if the present position obtained from the GPS receiver is correct or not with no measurement error. In other words, if the displayed interactive graphics coincides with that seen from the present position of the user in fact, it is possible to determine that the present position from the GPS receiver is correct (conventionally, it has been difficult for the user to check if the present position obtained from the GPS receiver is correct or not by himself or herself).

- (2) Further, according to the interactive graphics delivery system of the present invention, the user can display the spot on the corresponding map from the identification data of the interactive graphics while seeing the interactive graphics on a certain spot, so that the user can easily know where the place where the user can see the interactive graphics is located (the name of a place or a facility and the like).
- (3) Further, according to the interactive graphics delivery system of the present invention, the user can see the interactive graphics of one or plural spots corresponding to that retrieving data in real time on that place by inputting the retrieving data composed of a character string. Particularly, it is possible to offer “a virtual travel” which allows the user to see the actual scene at this moment on remote plural positions in series in real time.
- (4) According to the present invention, if the interactive graphics identification data for specifying each interactive graphics is composed of the position data indicating

the position of each live spot where the image input means is installed and the directional data indicating the direction in which that image input means shots the image, it becomes possible to offer a different interactive graphics depending on a direction in which the user sees even from the same spot. Then, it is possible to offer the interactive graphics which can reproduce a "live actual scene" in more detail and in real time.

- (5) In addition, according to the present invention, obtaining the present position of the user by means of a present position specifying means such as the GPS receiver, the interactive graphics of the live spot corresponding to this obtained present position is imported to be displayed. Accordingly, the user can use the GPS receiver, for example, in the following manner. Namely, when he or she is moving by a car, obtaining the present position by means of the GPS receiver, the user can see the spot on the map corresponding to that present position on the map of a screen (the system for this has been put into practical use as a map routing and drive guiding system to a destination for a car). In addition, at the same time, the user obtains the present position information from the GPS receiver and accesses to the corresponding image input means via the communication network. Then, the user imports the interactive graphics corresponding to the present position on line and displays it on the screen. Thereby, the user checks if the present position displayed on the map (many systems for displaying the present position of the user to be measured by the GPS receiver using an arrow on the map of the screen has been already put on the market) coincides with the interactive graphics or not while watching the map having the route to the destination listed thereon. Then, if the present position displayed on the map coincides with the interactive graphics, it is possible to check if the present position obtained from the GPS receiver is correct without a measurement error. If they do not coincide with each other, the user can see that the present position obtained from the GPS receiver is wrong. Further, without depending on the invention set forth in Claim 5 described here, by combining the conventional GPS receiver with the invention set forth in Claim 1, it is also possible to obtain the same effect as Claim 5 (as described above). In other words, the user himself or herself can check if the present position obtained from the GPS receiver is correct or not if the user reads out the map of a

predetermined area including the present position from the map database on the basis of the present position obtained from the GPS receiver, display it, and by clicking the spot near the present position indicated on that displayed map, imports the interactive graphics of one or plural spots near the spot clicked by the mouse on line.

- (6) In addition, according to the present invention, the image input means picks up the image seen toward plural directions from respective live spots. The live spot identification data for identifying respective live spots from each other is composed of the position data indicating the position of each live spot where the image input means is installed and the directional data indicating the direction in which that image input means shots the image. The present position specifying means includes the means for specifying the present position of the user and the means for specifying the progress direction of the user. The live spot identification data selecting means may indicate the live spot near (nearest) the present position of the user on the basis of the present position of the user that is specified by the present position specifying means (the coordinate data and the like, with latitude data and the longitude data) and the progress direction of the user (East, West, South, and North or the like) and may select the live spot identification data in a direction near (nearest) the progress direction of the user. Therefore, the user traveling by a car or the like can see the interactive graphics corresponding to the present position obtained from the GPS receiver at the same time while seeing the present position of the user himself or herself on the map displayed on the screen (the present position of the user himself or herself obtained from the GPS receiver is displayed by an arrow). Therefore, the user can check if the present position on the map measured by the GPS is actually correct or not by checking the spot on the map with the interactive graphics.
- (7) In addition, according to the present invention, by providing a marking means for marking so as to distinguish the portion designated by the user in the interactive graphics displayed by the display means from other portion, only a certain portion (for example, specific building, bridge, road, river, and park or the like) in the interactive graphics (it may be a moving image or a still image), so that it is possible to process the interactive graphics into a formation that is easily seen

depending on the user's object.

- (8) In addition, according to the present invention, by including the means for inputting a voice generated on that spot into the image input means in real time, this inputted voice is imported with a wire or without a wire in real time (including the case of browsing it by a browser for Internet and the case of transmitting it by the communication network or the like). Thereby, the user can know not only the interactive graphics (a live image of the actual scene, a moving image or a still image) but also "a live voice of the actual scene".
- (9) In addition, according to the present invention, further, by including an aroma input means for inputting aroma of the spot where the image input means is installed or its surrounding aroma, which is configured by an aroma sensor and a means for converting a signal from this aroma sensor into aroma digital data; a means for converting the aroma data from this aroma input means into fragrance blending data for generating an aroma similar to that aroma; and an aroma generating means for generating a desired aroma by blending a fragrance from the fragrance blending data, the user can sense not only the interactive graphics and a real voice but also can sense an actual aroma of the actual scene in real time in a remote place.

[Brief Description of the Drawing(s)]

[FIG. 1]

FIG. 1 is a view showing a configuration of hardware of a first embodiment or a second embodiment according to the present invention.

[FIG. 2]

FIG. 2 is a view showing a conceptual configuration of the first embodiment or the second embodiment according to the present invention.

[FIG. 3]

FIG. 3 is a view showing the constitution of a display of the first embodiment according to the present invention.

[FIG. 4]

FIG. 4 is a view showing an example of a map that is displayed on a display according to the first embodiment in the present invention.

[FIG. 5]

FIG. 5 is a block diagram showing a fourth embodiment according to the present invention.

[FIG. 6]

FIG. 6 is a block diagram showing a fifth embodiment according to the present invention.

[Description of the Reference Numerals and Signs]

- 1: personal computer (PC)
- 2: control apparatus
- 3: hard disk apparatus
- 4: CD-ROM
- 5: CD-ROM drive
- 6: key board
- 7: display
- 7a: upper half part of display
- 7b: lower half part of display
- 8: speaker
- 10: public circuit
- 11: computer for relay service
- 12, 12a, 12b: video camera
- 13, 13a, 13b: microphone
- 21: LCD
- 22: GPS receiver
- 23: control unit
- 24: server for map database (computer)
- 25: image input apparatus
- 26: key board
- 27: mouse
- 30: computer communication network
- 31: image input apparatus
- 34: CD-ROM player
- 35: CD-ROM

- (1) CAMERA, MICROPHONE
- (2) SERVER
- (3) COMPUTER FOR RELAY SERVICE
- (4) CONTROL APPARATUS
- (5) CD-ROM DRIVE
- (6) DISPLAY
- (7) SPEAKER
- (8) KEY BOARD
- (9) MOUSE
- (10) FIG. 1
- (11) FIG. 3
- (12) IMAGE, MAP
- (13) FIG. 4
- (14) STATION
- (15) TOWN

- (1) FIG. 2
- (2) IMAGE INPUT UNIT
- (3) IMAGE IMPORTING UNIT
- (4) CONTROL UNIT
- (5) DISPLAY UNIT, SPEAKER
- (6) MAP DATABASE REPRODUCING UNIT
- (7) RETRIEVING UNIT
- (8) MAP DATABASE
- (9) LIVE-ACTION IDENTIFICATION DATABASE
- (10) FIG. 5
- (11) PROGRESS DIRECTION INPUT UNIT
- (12) GPS RECEIVER
- (13) CONTROL UNIT
- (14) LIQUID CRYSTAL DISPLAY
- (15) KEY BOARD, MOUSE
- (16) PUBLIC CIRCUIT

- (17) SERVER FOR MAP DATABASE (COMPUTER)
- (18) IMAGE INPUT APPARATUS
- (19) FIG. 6
- (20) CD-ROM PLAYER
- (21) INTERNET
- (22) IMAGE INPUT APPARATUS

(19) 日本国特許庁 (J P)

(12) 公開特許公報 (A)

(11) 特許出願公開番号

特開平10-66058

(43) 公開日 平成10年(1998) 3月6日

(51) Int.Cl. ⁴	識別記号	庁内整理番号	F I	技術表示箇所
H 0 4 N	7/18		H 0 4 N	7/18 D
G 0 6 F	17/30		G 0 8 B	5/00 Z
G 0 8 B	5/00		H 0 4 H	1/00 E
H 0 4 H	1/00		H 0 4 N	7/10
H 0 4 N	7/10		G 0 6 F	15/40 3 7 0 C

審査請求 有 請求項の数 9 F D (全 15 頁)

(21) 出願番号 特願平8-355003

(22) 出願日 平成8年(1996) 12月20日

(31) 優先権主張番号 特願平8-172930

(32) 優先日 平8(1996) 6月11日

(33) 優先権主張国 日本 (J P)

(71) 出願人 595100934

鯨田 雅信

福岡県北九州市小倉南区徳力新町2-1-

11 (鯨田ビル1F)

(72) 発明者 鯨田 雅信

福岡県北九州市小倉南区徳力新町2-1-

11 (鯨田ビル1F)

(54) 【発明の名称】 実況映像提供システム

(57) 【要約】

【課題】 ユーザーに、任意の地点の実際の状況を映像でリアルタイムに提供することができる実況の映像を提供するシステムを提供する。

【解決手段】 公衆への開示が可能な多数の地点の実況映像を入力するために各地点に設けられた映像入力手段と、これらの各映像入力手段から入力される各実況映像を無線又は有線で送信する映像送信手段と、前記各地点を互いに識別するための識別データを、所定のキーと関連付けながら、記録する実況地点データベースと、前記の所定のキーを入力するキー入力手段と、このキー入力手段から入力されたキーに基づいて前記実況地点データベースから対応する地点の実況映像の識別データを検索する検索手段と、この検索手段により検索された識別データに基づいて、対応する実況映像を前記各映像送信手段から受信する映像受信手段と、この受信された実況映像を出力する表示手段とからなる。

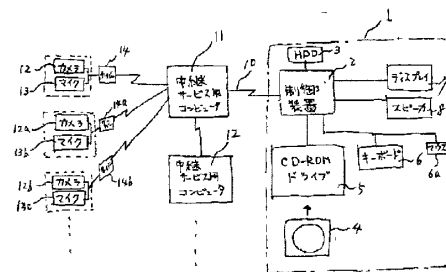

【特許請求の範囲】

【請求項1】 公衆への開示が可能な多数の実況地点の実況映像をそれぞれリアルタイムに常時入力するために各実況地点にそれぞれ設けられた映像入力手段と、地図上の各地点と、前記各実況映像を互いに識別するための実況映像識別データとを、互いに対応付けながら、記録する地図データベース手段と、

前記地図データベース手段により表示された地図上のある地点に対応する実況映像識別データに基づいて、該当する実況映像を該当の前記映像入力手段からオンラインで取り込む映像取り込み手段と、

この映像取り込み手段により取り込まれた実況映像をリアルタイムに表示する表示手段と、からなる、実況映像提供システム。

【請求項2】 公衆への開示が可能な多数の実況地点の実況映像をそれぞれリアルタイムに常時入力するために各実況地点にそれぞれ設けられた映像入力手段と、地図上の各地点と、前記各実況映像を互いに識別するための実況映像識別データとを、互いに対応付けながら、記録する地図データベース手段と、

ある実況映像を表示している場合に、その実況映像を識別する実況映像識別データをキーとして、前記地図データベース手段から、該当する実況映像の実況地点を含む所定領域の地図を示すための地図データを抽出する地図データ抽出手段と、

この地図データ抽出手段により抽出された地図データに基づいて地図を表示する表示手段と、からなる、実況映像提供システム。

【請求項3】 公衆への開示が可能な多数の実況地点の実況映像をそれぞれリアルタイムに常時入力するために各実況地点にそれぞれ設けられた映像入力手段と、前記各実況映像を互いに識別するための実況映像識別データを、文字列・記号列・図形又は映像などから成る検索データと関連付けながら、記録する実況映像識別データベース手段と、

前記の文字列・記号列・図形又は映像などから成る検索データを入力する検索データ入力手段と、

この検索データ入力手段から入力された検索データに基づいて、前記実況映像識別データベース手段から、関連する一つ又は複数の実況映像識別データを選択する実況映像識別データ選択手段と、

この選択された実況映像識別データに基づいて、該当する実況映像をオンラインで取り込む映像取り込み手段と、

この映像取り込み手段により取り込まれた実況映像を表示する表示手段と、からなる、実況映像提供システム。

【請求項4】 請求項1、2又は3において、前記映像入力手段は、前記各実況地点から複数の方向に向かって見える映像をそれぞれ撮像するものであり、前記各実況映像を互いに識別するための実況映像識別デ

ータは、前記映像入力手段が設けられた各実況地点の位置を示す位置データと、その映像入力手段が撮影する方向を示す方向データと、から構成されている、ことを特徴とする実況映像提供システム。

【請求項5】 公衆への開示が可能な多数の実況地点の実況映像をそれぞれリアルタイムに常時入力するために各実況地点にそれぞれ設けられた映像入力手段と、前記各実況映像を互いに識別するための実況映像識別データを記録する実況映像識別データ記録手段と、

ユーザーの現在位置を特定する現在位置特定手段と、この現在位置特定手段により特定されたユーザーの現在位置に基づいて、前記実況映像識別データ記録手段から、前記ユーザーの現在位置の近くにある一つ又は複数の実況地点の実況映像を特定するための実況映像識別データを選択する実況映像識別データ選択手段と、

この選択された実況映像識別データに基づいて、該当する実況映像をオンラインで取り込む映像取り込み手段と、

この映像取り込み手段により取り込まれた実況映像をリアルタイムに表示する表示手段と、からなる、実況映像提供システム。

【請求項6】 請求項5のシステムにおいて、前記映像入力手段は、前記各実況地点から複数の方向に向かって見える映像をそれぞれ撮像するものであり、前記各実況映像を互いに識別するための実況映像識別データは、前記映像入力手段が設けられた各実況地点の位置を示す位置データと、その映像入力手段が撮影する方向を示す方向データと、から構成されており、前記現在位置特定手段は、ユーザーの現在位置を特定する手段とユーザーの進行方向を特定する手段とを含んでおり、

前記実況映像識別データ選択手段は、前記現在位置特定手段により特定されたユーザーの現在位置及びユーザーの進行方向に基づいて、ユーザーの現在位置からユーザーの進行する側の方向に存在する実況地点であってユーザーの現在位置に近い実況地点の位置を示す位置データと、ユーザーの進行方向を示す方向データと、から成る実況映像識別データを、選択するものである、ことを特徴とする実況映像提供システム。

【請求項7】 請求項1から6までのいずれかにおいて、さらに、前記表示手段により表示された実況映像の中のユーザーが指定した部分に対して、他の部分と区別するためのマーキングをするためのマーキング手段を備えたことを特徴とする実況映像提供システム。

【請求項8】 請求項1から7までのいずれかにおいて、さらに、前記映像入力手段の近傍に備えられ、前記映像入力手段が設置された実況地点又はその周辺に発生している音声をリアルタイムに入力する音声入力手段と、

前記表示手段の近傍に備えられ、前記音声入力手段からの音声出力される音声出力手段と、が備えられている、実況映像提供システム。

【請求項9】 請求項1から8までのいずれかにおいて、さらに、前記映像入力手段の近傍に備えられ、匂いセンサと、この匂いセンサからの信号を匂いのデジタルデータに変換する手段とから構成され、前記映像入力手段の設置された実況地点又はその周辺の匂いを入力するための匂い入力手段と、

この匂い入力手段からの匂いデータを、その匂いに近似した匂いを発生させるための芳香剤調合データに変換する変換手段と、

前記表示手段の近傍に備えられ、前記芳香剤調合データから芳香剤を調合して所望の匂いを発生させる匂い発生手段と、を含む実況映像提供システム。

【0001】

【発明の詳細な説明】

【発明の属する技術分野】 本発明は、各地点のリアルタイムの実況映像を地図等に関連させて提供することができる、実況映像提供システムに関する。また本発明は、前記実況映像から、その実況映像の地点を含む地図を表示させるシステムに関する。

【0002】

【従来の技術】 従来より、各地点の映像をCD-ROM又はハードディスクなどの記録媒体に記録しておき、それを所定のキーワード等の検索データに基づいて検索して表示するシステムが存在している。

【0003】

【発明が解決しようとする課題】 しかしながら、これらの記録媒体に記録された映像は、「過去のもの」である（「生のもの」ではない）。そのため、実際の景色などは、季節の移り変わり、その日の天候、道路や建物の工事状況などにより、日々刻々変遷していくものであるのに、ユーザーが見ることができるのは「古い（新鮮でない）」ものでしかないという問題がある。また、仮にその記録媒体に記録された映像が更新直後のものだとしても、「今現在のこの瞬間のリアルタイムの状況を見たい」というユーザーの希望に応えることはできない。さらに、記録媒体への映像データの更新を頻繁に行うことは非常にコストがかかってしまうという問題もある。

【0004】 本発明はこのような従来技術の問題点に着目してなされたもので、ユーザーに、任意の地点の実際の状況を映像でリアルタイムに提供することができる実況映像提供システムを提供することを目的とする。また、本発明では、逆に、前記実況映像から、その実況映像の地点を含む地図を表示させるシステムを提供することを目的とする。

【0005】

【課題を解決するための手段】

（関連技術） 本発明の「従来技術」に該当するかどうか（本願の「優先日（1996年6月11日）」より前から公知の事実であるかどうか）は明らかではないが、本願（特許法41条の国内優先日主張を伴う後の出願）の出願日の時点で本発明者が認識している「関連技術」としては、次のようなものが存在している。

（イ）ダイヤモンド社発行「週間ダイヤモンド別冊 1996. 8号 インターネット超時間術」では、次のような記述がある。「インターネットではいま、テレビカメラを据えて、観光名所を同時中継しているケースが多くなってきた。自宅の机の上から、スフィンクスの前とか、パリ凱旋門、ヒマラヤを望む丘など世界的な文化遺産、観光名所のジャストナウを、やがて眺めることができるだろう。」（同書 76頁）

「ホテルがロビーや玄関前にカメラを置いて、そのカメラをオンラインにしてリモコンで見るというのはどうですか。ウェブでそれを見て、「けっこう混んでるな」とか「おっ、あいつがいる」とか。そういうオンラインのカメラというのはウェブ上にも増えつつあるんです。」（同書 82頁）

インターネットのホームページの紹介として、「歴史街道 <http://www.kiis.or/rekishi/> 泰 恵子さん

歴史街道のメインルートである伊勢、飛鳥、奈良、京都、大阪、神戸を説明文と写真（100枚以上）で散策することができます。（中略）各項目へのアクセスは地域別、時代別による検索と地図上でのマウスによる選択（クリックابلマップ）があります。現在の情報提供は説明文と写真のみですが、（今後は）動画や音声情報も提供していく予定です。」（同書 133頁）

（ロ）1996年6月16日付け日本経済新聞は、「魔法の箱を駆使 世界の見方覆す」とい見出しの記事で、コンピュータ・アーティスト藤幡正樹氏を紹介する記事の中で、次のように述べている。「最近では教鞭をとる慶応大学の学生らとインターネットを使ったプロジェクトに没頭している。例えば湘南藤沢キャンパスに取り付けたカメラが写す富士山の映像を、24時間リアルタイムで発信する試みを始めた。1日千人に上る世界中からのアクセス・ユーザーは、自分のパソコンでカメラの向きを変えたり、ズームインしたりすることもできる。」

（ハ）ダイヤモンド社により1996年8月31日につ発行された「週間ダイヤモンド」の84頁には、「超整理日記 地図と写真の仮想旅行術（野口悠紀雄）」という記事の中に、次のような記載がある。「インターネットで「バーチャル・ツアー」というものがある。画面に出ている地図をクリックすると、その地点の写真が現れるというものだ。」

（ニ）1996年9月3日付け日本経済新聞の広告欄において、「操作性高まる地図情報システム 住友電工システムズ」という見出しで、次のような記述がある。

「住友電工システムズがこの度開発、販売したWindows 95専用デジタル道路地図「AtlaMate／Windows 95版」は、…。(中略) 同製品はマルチメディア機能として、地図上に静止画や動画、音声の張り付けが可能となっている。」

また、この広告欄の中の「AtlaMate／Windows 95版」の仕様書の記載の中に、次のような記載がある。「豊富な登録機能 写真などの静止画、ビデオなどの動画、また音声などを地図上に登録可能」

(ホ) 1996年9月30日付け日本経済新聞は、「インターネット活用 自宅で自然を感じて」とい見出しの記事で、次のように述べている。「高知県佐川町はNECと共同で、インターネットで自然の風景を生中継で楽しめる「さかわインターネット放送局」を開設した。同町の虚空蔵山(標高675m)山頂にカメラを設置し、自宅や職場のパソコンからカメラを自由に動かして、足摺岬から室戸岬までの眺望を楽しめる。佐川地場産センターに開局した。カメラの映像を約3km離れたふもとの町営施設、永野町民館のカメラ制御装置に無線で伝送し、静止画像をインターネット上に提供する。パソコンからカメラを自由に遠隔操作し、左右約300度、上下約60度のパノラマを最大10倍のズームで楽しめる。インターネット放送局のアドレスはhttp://www.meshnet.or.jp/sakawa/NECは5月からインターネット放送局を全国展開している。北海道の松前町、美瑛町、佐呂間町で開局し、2～3年以内に100ヶ所の観光地、景勝地にカメラを設置する計画。」

以上のように、本発明に関連する技術は、さまざまのがある。しかし、これらはいずれも、本発明と関連しているが、本発明はこれらの関連技術をさらに発展させたものであり、これらの関連技術は本発明の進歩性を否定するものではない。

【0006】前述のような従来技術の課題を解決するための本発明による実況映像提供システムは、次のようなものである。

(1)本発明による実況映像提供システムは、公衆への開示が可能な多数の実況地点の実況映像をそれぞれリアルタイムに常時入力するために各実況地点に設けられた映像入力手段と、前記各実況地点の実況映像を互いに識別するための実況映像識別データを、地図データベースの地図上の各地点とそれぞれ関連・対応付けながら、記録する実況映像識別データベース手段と、前記地図データベースの地図上で指定された地点に基づいて、前記実況映像識別データベース手段から、対応する一つ又は複数の実況映像識別データを検索する検索手段と、この検索手段により検索された実況映像識別データに基づいて、対応する実況映像をリアルタイムに無線又は有線で取り込む(ネットワークで送信させること又はインターネット用ブラウジング・ソフトウェアでアクセスして閲覧す

ることなどの方法により取り込む)映像取り込み手段と、この映像取り込み手段により取り込まれた実況映像(動画又は静止画)を出力する表示手段と、からなるものである。

(2)また本発明は、公衆への開示が可能な多数の実況地点の実況映像をそれぞれリアルタイムに常時入力するために各実況地点に設けられた映像入力手段と、地図とその地図上の各地点を特定するための座標データとを記録する地図データベースと、前記地図データベースの中の座標データと、前記各実況映像を互いに識別するための実況映像識別データとを、互いに関連又は対応付けながら、記録する実況映像識別データベース手段と、ある実況映像を表示している場合に、その実況映像を互いに識別する実況映像識別データをキーとして、前記実況映像識別データベースから、その実況映像の実況地点に対応又は関連する一つ又は複数の地図上の地点を検索する検索手段と、この検索手段により検索された地図上の地点を含む所定領域の地図を示す地図データを抽出する地図データ抽出手段と、この地図データ抽出手段により抽出された地図データにより地図を出力する表示手段と、からなるものである。

(3)また、本発明による実況映像提供システムは、公衆への開示が可能な多数の実況地点の実況映像をそれぞれリアルタイムに常時入力するために各実況地点に設けられた映像入力手段と、前記各実況映像を互いに識別するための実況映像識別データを、文字列・記号列・図形又は映像などから成るキーと関連付けながら、記録する実況映像識別データベース手段と、前記の文字列・記号列・図形又は映像などから成るキーを入力するキー入力手段と、このキー入力手段から入力されたキーに基づいて、前記実況映像識別データベース手段から、関連する一つ又は複数の実況映像識別データを検索する検索手段と、この検索手段により検索された実況映像識別データに基づいて、対応する実況映像を取り込む(ネットワークより送信させるとインターネット用ブラウザにより閲覧する場合などを含む)映像取り込み手段と、この映像取り込み手段により取り込まれた実況映像(動画又は静止画)を出力する表示手段と、からなるものである。

(4)なお、本発明において、前記映像入力手段は一つの実況地点から複数の方向の映像を撮像するものであり(例えば、一つのビデオカメラを旋回してある複数の方向にきたときに撮像する場合や、複数のビデオカメラを複数の方向にそれぞれ備え付けて同時に撮像する場合など)、前記各実況映像を特定するための実況映像識別データは、前記映像入力手段が設けられた各実況地点の位置を示す位置データとその映像入力手段が撮像する方向を示す方向データとから構成されていることが望ましい。

(5)また本発明は、公衆への開示が可能な多数の実況地点の実況映像をそれぞれリアルタイムに常時入力するた

めに各実況地点にそれぞれ設けられた映像入力手段と、前記各実況映像を互いに識別するための実況映像識別データ（緯度データ及び経度データの座標データなどから成る）を記録する実況映像識別データ記録手段と、ユーザーの現在位置を特定する現在位置特定手段（従来より公知のGPS受信機など）と、この現在位置特定手段により特定されたユーザーの現在位置（緯度データ及び経度データの座標データなどから成る）に基づいて、その現在位置に近い一つ又は複数の実況地点に対応又は関連する一つ又は複数の実況映像識別データを選択する実況映像識別データ選択手段と、この選択された実況映像識別データに基づいて、対応する実況映像をオンラインで取り込む（ネットワークを介してアクセスして閲覧する場合と送信させる場合などを含む）映像取り込み手段と、この映像取り込み手段により取り込まれた実況映像（動画又は静止画）をリアルタイムに表示する表示手段と、からなるものである。

(6)また、本発明では、前記映像入力手段は、上記(4)と同様に、前記各実況地点から複数の方向に向かって見える映像をそれぞれ撮像するものであり、前記各実況映像を互いに識別するための実況映像識別データは、前記映像入力手段が設けられた各実況地点の位置を示す位置データとその映像入力手段が撮像する方向を示す方向データと、から構成されており、前記現在位置特定手段は、ユーザーの現在位置を特定する手段とユーザーの進行方向を特定する手段とを含んでおり、前記実況映像識別データ選択手段は、前記現在位置特定手段により特定されたユーザーの現在位置を示すデータ（緯度データ及び経度データから成る位置座標データなど）及び進行方向を示すデータ（東西南北など）に基づいて、ユーザーの現在位置からユーザーの進行する方向に位置し且つユーザーの現在地点に近い位置にある実況地点の実況映像であってしかもユーザーの進行方向に近い方向を写す実況映像（動画又は静止画）を特定するための実況映像地点識別データを選択するものである。

(7)また、本発明では、前記表示手段に表示された実況映像（動画又は静止画）の中のユーザーが指定した部分に対して他の部分と区別するためのマーキングをするためのマーキング手段を備えるのがよい。

(8)また、本発明において、前記映像入力手段は、その地点において発生している音声を実況映像入力手段にも備えているのがよい。

(9)また本発明では、さらに、前記映像入力手段の近傍に備えられ、匂いセンサと、この匂いセンサからの信号を匂いデジタルデータに変換する手段とから構成され、前記映像入力手段の設置された地点又はその周辺の匂いを入力するための匂い入力手段と、この匂い入力手段からの匂いデータを、その匂いに近似した匂いを発生させるための芳香剤調合データに変換する変換手段と、前記表示手段の近傍に備えられ、前記芳香剤調合データから芳

香剤を調合して所望の匂いを発生させる匂い発生手段と、を含むのがよい。なお、この(9)において、前記の「その匂いに近似した匂いを発生させるための芳香剤調合データに変換する変換手段」は、前記匂い入力手段と直接に接続され、この変換手段がコンピュータ通信ネットワークを介して前記匂い発生手段に接続されていてもよいし、あるいは、前記入力入力手段とコンピュータ通信ネットワークを介して接続され、この変換手段が直接に前記匂い発生手段に接続されていてもよい。

【0007】

【発明の実施の形態】

実施形態1. 次に、図1～4を参照して、本発明の実施形態1を説明する。図1において、1はユーザーが使用するパーソナルコンピュータ（パソコン）で、CPU及び通信モデム等より成る制御装置2と、コンピュータプログラム及びデータが記録されたハードディスク装置3と、コンピュータプログラム及びデータが記録されたCD-ROM4を駆動するためのCD-ROMドライブ5と、データ入力するためのキーボード6及びマウス6aと、画像を出力するためのディスプレイ7と、音声を出力するためのスピーカ8とより、構成されている。

【0008】前記制御装置2は、インターネット等のコンピュータネットワーク川公衆回線10を介して、中継サービス用コンピュータ11に接続されている。この中継サービス用コンピュータ11には、多数の実況地点にそれぞれ設置されたビデオカメラ12、12a、12b及び集音マイク13、13a、13bを制御し且つこれらのビデオカメラ12及び集音マイク13からのデータを記録し通信ネットワークを介して閲覧させるためのコンピュータ（サーバー）14、14a、14bが、接続されている。これらの多数のビデオカメラ12及びマイク13等により入力された映像データ及び音声データは、ユーザー側からの要求により、コンピュータ14及び中継サービス用コンピュータ11を介して、ユーザー側に送信できるようになっている。なお、前記ビデオカメラ12は、各実況地点において、それぞれ4個ずつ設置され、それらの4個のビデオカメラは、それぞれ東西南北の4つの方向の映像を撮像するように、設置されていることが望ましい。

【0009】また、前記中継サービス用コンピュータ11は、他の多数の中継サービス用コンピュータ12なども接続されており、例えば、ある中継サービス用コンピュータ11に接続されたユーザーは、この中継サービス用コンピュータ11を介して他の中継サービス用コンピュータ12などから、それに接続されたコンピュータ（サーバー）を介してビデオカメラ及びマイクから入力されたデータを取り込めるようになっている。この場合の映像や音声の取り込みの方法は、そのビデオカメラやマイクからの情報を電子メールに添付させて送信させる方法や、そのビデオカメラ及びマイクの入力情報を提供

するためのホームページがコンピュータ・ネットワーク上に開設されており、このホームページをユーザー側がインターネット用のブラウザ・ソフトウェア（閲覧ソフト）により取り込みに行く方法（いわば、コンピュータ・ネットワーク上のホームページをユーザー側のパソコンのハードディスクのように使用する方法）などの様々な方法が有り得る。

【0010】この実施形態1では、前記CD-ROM4には、地図データとこの地図上の各地点を特定するためのアドレスデータとを関連させて記録する地図データベースと、このアドレスデータと、前記各実況地点（前記ビデオカメラ12及びマイク13が設置された各場所）の実況映像を識別するための映像識別データとを、互いに関連付け・対応付けて記録する実況映像データベースと、これらの前記地図データベースを再生する再生プログラムと、前記実況映像データベースを検索する検索プログラムと、この検索された実況映像識別データからそれに対応する実況映像を取り込んで表示するためのプログラムとが、記録されている。

【0011】今、例えば大阪に住んでいるユーザーが、「自分の故郷の神奈川県夏の湘南海岸の海岸線に沈む夕陽の景色を見たい」と考えたとする。その場合、例えば、ユーザーが地図データベースを再生させて湘南海岸を含む所定領域の地図を画面表示させ、その画面上で前記の湘南海岸の地点をマウス6aでクリックしたとする。すると、制御装置2は、この入力に基づいて、前記地点データベースから、この地図上の地点に対応するアドレスデータを検索する。そして、この検索されたアドレスデータに基づいて、前記実況映像データベースから、対応する実況地点の実況映像を示す実況映像識別データを検索する。そして、この検索された実況映像識別データに基づいて、中継サーバ用コンピュータ11にアクセスして、前記の実況映像識別データに対応する実況地点に設置されたビデオカメラ及びマイク（且つ、前記実況映像識別データが撮像方向をも特定したものであるときは、その撮像方向と対応する方向に設置されたビデオカメラ及びマイク）からの映像データ及び音声データをオンラインで取り込んで、ディスプレイ7及びスピーカ8によりリアルタイムに出力する。このとき出力される映像及び音声は、現時点のリアルタイムの映像及び音声なので、ユーザーはあたかもその現場に実際にいるような感覚・感動を得ることができる。すなわち、従来からも、例えば湘南海岸などの海岸の映像を記録し、それらをキーワードなどで検索して出力できるCD-ROMなどは存在している。そして、これらのCD-ROMに記録された映像は、プロのカメラマンが絶好の日和・時刻（例えば夕陽のきれいな時刻）の絶好の角度から美しく撮影したものである。これに対して、この実施形態で提供される映像は、雨天のときも曇りのときもあるし、時刻も絶好の景色が見られる時刻ではないかもしれ

ない。しかし、ユーザーにとっては、「今この時点・この瞬間の映像（二度とない映像）である」ということが、ひとつの「臨場感」「感動」を生むことになる。つまり、「今、湘南海岸に沈む夕陽を見たい」とユーザーが思った場合、過去の記録に過ぎない記録された「湘南海岸の夕陽」の映像ではなく、「今この瞬間の湘南海岸の夕陽」の映像を見られなければ、ユーザーにとっては大きな感動は得られない。この実施形態はこのようなユーザーの希望に答えることができるものなのである。

【0012】なお、ここで、以上の図1について説明した実施形態の構成を図2を参照してもう一度説明する。この図2は、実施形態の構成を機能的・概念的に示したものである。図2において、符号32は、コンピュータネットワーク（コンピュータ通信網）30に接続され、各地の実況映像と音声を実況映像入力部である。また、符号24は、前記地図データベース26とその再生プログラムとその検索プログラム、前記実況映像データベース25とその検索プログラム、及び前記実況映像識別データから通信ネットワークを介して該当する実況映像を取り込むためのプログラムなどが記録されたCD-ROMである。また図2において、21は前記CD-ROM24に記録された前記地図データベース26を再生するための地図データベース再生部、22はこの地図データベース再生部21からの信号を受けて表示部27及びスピーカ28を制御して所定の画像及び音声出力する制御部である。また23は、前記制御部22からの信号を受けて、前記地図データベースが再生された画面上でユーザーが指定（マウスでクリック）した地点のアドレスデータに基づいて、前記実況映像データベース25から、対応する実況映像の識別データを検索する検索部である。制御部22は、この検索部23からの実況映像の識別データに基づいて、映像取り込み部（例えばインターネットのホームページ閲覧用ソフトウェアであるブラウザを記録し実行する装置）26を制御して、コンピュータネットワーク用通信回線30を介して映像入力部32にアクセスし、そこから、オンラインで、リアルタイムの実況映像及び音声を取り込む。制御部22は、このオンラインで取り込まれた実況映像と音声を、前記地図データベース26からの再生画像（地図画像）と関連させながら、前記表示部27及びスピーカ28によりリアルタイムに出力させる。

【0013】次に、前記の図1の制御装置2に制御されながら、前記ディスプレイ7により表示される画面を、図3及び図4に基づいて説明する。前記CD-ROM4に記録された各プログラムにより、ディスプレイ7には、図3に示すように、その上半分7aに実況映像が表示され、その下半分7bに地図が表示されるようになっている。この実施形態1を使用するときは、ユーザーは、まず図1の前記CD-ROM4を駆動して、前記地

図データベースから前記ディスプレイ7の下半分7bに希望する地図を表示させる。CD-ROM4に記録された地図データベースの中のどの部分の地図を表示させるかは、例えば、地名などのキーワードから地図データを検索して表示させればよい（このような技術は従来より公知である）。そして、本実施形態では、この表示された地図には、例えば図4のア、イ、ウ、エ、オ、カ、キに示すように、各地点を示す点が所定の色（例えば赤色）に着色されて表示されている。これらの図4のア、イ、ウ、エ、オ、カ、キで示す各点の中で、図4のア、イ、ウ、及びエは、図1のビデオカメラ12及びマイク13に対応している。すなわち、この実施形態1では、図1のビデオカメラ12は、それぞれ互いに異なる方向を撮像するように図4のア、イ、ウ、及びエの位置に設置された4個のビデオカメラにより構成されている。また、図1のマイク13は、それぞれ互いに異なる方向を集音するように設置された4個のマイクにより構成されている。つまり、ビデオカメラ12について説明すると、ビデオカメラ12を構成する4個のビデオカメラの中で、図4のアの位置に設置されたビデオカメラは、図の西方向（左方向）に向けて撮像しており、“1428A”の映像識別データを有する実況映像を生成する。また、図4のイの位置に設置されたビデオカメラは、図の南方向（下方向）に向けて撮像しており、“1428B”の映像識別データを有する実況映像を生成する。また、図4のウの位置に設置されたビデオカメラは、図の東方向（右方向）に向けて撮像しており、“1428C”の映像識別データを有する実況映像を生成する。また、図4のエの位置に設置されたビデオカメラは、図の北方向（上方向）に向けて撮像しており、“1428D”の映像識別データを有する実況映像を生成する。また、前記の図4のア、イ、ウ、エ、オ、カ、キで示す各点の中で、図4のオ、カ、及びキは、図1のビデオカメラ12a及びマイク13aに対応している。すなわち、この実施形態1では、図1のビデオカメラ12aは、それぞれ互いに異なる方向を撮像するように図4のオ、カ、及びキの位置に設置された3個のビデオカメラにより構成されている。また、図1のマイク13aは、それぞれ互いに異なる方向を集音するように設置された3個のマイクにより構成されている。つまり、ビデオカメラ12aについて説明すると、ビデオカメラ12aを構成する3個のビデオカメラの中で、図4のオの位置に設置されたビデオカメラは、図の北西方向（左上方向）に向けて撮像しており、“1429A”の映像識別データを有する実況映像を生成する。また、図4のカの位置に設置されたビデオカメラは、図の東南方向（右下方向）に向けて撮像しており、“1429B”の映像識別データを有する実況映像を生成する。また、図4のキの位置に設置されたビデオカメラは、図の東方向（右方向）に向けて撮像しており、“1429C”の映像識別データを

有する実況映像を生成する。以上のように、この図4を参照して説明する実施形態では、地図上の各地点を識別するためのアドレスデータ（“1428”や“1429”など）と同一実況地点での各ビデオカメラの撮像方向を示すデータ（“A”“B”“C”“D”など）との組合せと、各地点の実況映像を識別するための実況映像識別データ（“1428A”や“1429A”など）とを、互に対応させて記録している。より詳細に述べると、この図4の例では、地図上の1つのアドレスデータ“1428”（図4の中央の交差点の領域を識別するアドレスデータ）については、“1428A”“1428B”“1428C”及び“1428D”の4つの撮像方向をそれぞれ示す4つの実況映像識別データが、対応させて記録されている。また、地図上の1つのアドレスデータ“1429”（図1の図示左側の交差点の領域を識別するアドレスデータ）については、“1429A”“1429B”及び“1429C”の3つの撮像方向を示す3つの実況映像識別データが、対応させて記録されている。なお、この図4の例では、実況映像識別データ（例えば“1428A”）を、地図上のアドレスデータ（例えば“1428”）と方向データ（例えば“A”）との組合せにより構成しているが、本発明では、必ずしも、実況映像識別データの中に地図上のアドレスデータをそのまま使用する必要はない。例えば、地図上のアドレスデータは地図全体を均等に割り付けて構成した番地データ（又は座標データ）とし、実況映像識別データはビデオカメラが実際に取り付けてある地点の識別コード（例えば、ビデオカメラの設置順の連続番号）と方向データとの組合せにより構成する、などのようにすることもできる。

【0014】この図4の例では、前記各ビデオカメラ12及びマイク13がそれぞれ映像及び音声を入力して得られる実況映像（ここでの「実況映像」という用語は、原則として、ビデオカメラで入力した映像データとマイクで入力した音声データとの両者を含む意味で使用している）の識別データには、その地点を示すデータとそのビデオカメラ12が撮影している方向（これはマイク13が集音しようとする方向と一致している）とから、構成されている。つまり、実況映像は、各地点とその撮像方向とで互いに識別されており、「実況映像識別データ」は、各地点を示すデータと撮影又は集音の方向を示すデータとから、構成されている。だから、同じ地点でも、撮影する方向（東西南北などの方向）が違えば別の識別データを有する別の実況映像となる。このことを図4で説明すると、図4の“A”で示すアドレスデータ（1428A）を有する地点は、（1428A）という映像識別データを有する実況映像と対応しており、この（1428A）という識別データを示す実況映像は、図4の“A”の地点からAの方向（図面に向かって左の方向）を撮影した映像である。また、図4の“イ”で示す

アドレスデータ(1428B)を有する地図上の地点は、(1428B)という識別データを有する実況映像と対応しており、この(1428B)という識別データを示す実況映像は、図3の「イ」の地点からBの方向(図面に向かって下の方向)を撮影した映像である。また、図4の「ウ」で示すアドレスデータ(1428C)を有する地点は、(1428C)という識別データを有する実況映像と対応しており、この(1428C)という識別データを示す実況映像は、図4の「ウ」の地点からCの方向(図面に向かって右の方向)を撮影した映像である。また、(1428D)というアドレスデータを有する図4の「エ」で示す地点は、(1428D)という識別データを有する実況映像と1対1に対応しており、この(1428D)という識別データを示す実況映像は、図4の「エ」の地点からDの方向(図面に向かって上の方向)を撮影した映像である。さらに、図4において、アドレスデータ(1429A)を有する「オ」で示す地点は、(1429A)という識別データを有する実況映像と対応しており、この(1429A)という識別データを示す実況映像は、図4の「オ」の地点からAの方向(図面に向かって左上の方向)を撮影した映像である。また、図4の(1429B)というアドレスデータを有する「カ」で示す地点は、(1429B)という識別データを有する実況映像と対応しており、この(1429B)という識別データを示す実況映像は、図4の「カ」の地点からBの方向(図面に向かって右下の方向)を撮影した映像である。また、図4の(1429C)というアドレスデータを有する「キ」で示す地点は、(1429C)という識別データを有する実況映像と対応しており、この(1429C)という識別データを示す実況映像は、図4の「キ」の地点からCの方向(図面に向かって右の方向)を撮影した映像である。

【0015】以上から分かるように、この図4の例では、1428は、図4の地図の中央に位置する交差点の領域(この図4の例では、この交差点の領域を「実況地点」という言葉で呼んでいる)を示す地図上のアドレスデータであり、A、B、C、Dはその交差点領域(実況地点)からの撮影(及び集音)の方向を示している。また同様に、図4の例では、1429は、図4の地図の左端の交差点の領域(実況地点)を示す地図上のアドレスデータであり、A、B、Cはその交差点(実況地点)内の各場所からの撮影(及び集音)の方向を示している。また、この図4の例では、実況映像の識別データは、前記地図上の各実況地点の位置を示すアドレスデータ(「1428」、「1429」など)と前記方向を示すデータ(A、B、C、Dなど)との組合せにより、構成されている。

【0016】したがって、ユーザーは、この図4の地図を見ながら、自分がこれから行きたいと思う場所が例えば図4の1428で示す交差点の領域だとして、「今、

この交差点の状況はどうなっているか(混雑しているのかどうか、どういう人達がどういう服装で通行しているのか、など)知りたい、そのために実況映像を見たい」と思えば、図4で示す地図上のア～エの地点のいずれかをマウスなどのポインティングデバイスでクリックすればよい。すると、前記制御装置2により、その地図上のアドレスデータに対応する実況映像識別データが検索され(前記実況映像データベースから)、この検索された実況映像識別データに基づいて、該当する実況映像がコンピュータ・ネットワークを介して取り込まれて、ディスプレイ7の上半分7aに表示される。

【0017】またユーザーは、これから自分が行きたいと思う場所と今自分が居る場所との間の交通経路を地図上で求めて(これは従来から公知の技術で既に実現されている)、その経路上にある地点の実況映像を順番に表示していく(一つの実況映像の表示時間を例えば5秒として、5秒毎に次の実況映像を順番に表示していく)こともできる。またユーザーは、自分が自動車を運転しているとき、GPS受信機で受信した測位情報や各種のセンサにより得た測位情報から現在の位置を地図上で求め(これは従来より公知の技術で既に実現されている)、その地図上で求めた自分の現在位置に対応する地点から、前記実況映像の識別データを求めて、その識別データに基づいてネットワーク上のサーバー(例えば図1の中継サービス用コンピュータ11)を通して対応する実況映像を取り込んで表示する、こともできる。これにより、ユーザーは、地図上の現在位置(GPS受信機やセンサからの情報に基づいて推測した現在位置)と実際の現在位置とが本当に一致しているかどうかを目視により確認することができる。つまり、上記のようにして求められた実況映像識別データに基づいてディスプレイ7に表示された実況映像と自分が自動車の内部から外部を見て得られる実際の景色とが一致していれば、前記のGPSにより推測した現在位置は計測誤差がなく正しいということになるか、一致していなければ前記の推測した現在位置は正しくないということになる。

【0018】なお、前記制御装置2と中継サービス用コンピュータ11の接続は無線でもよいこと、前記中継サービス用コンピュータと各ビデオカメラ12及びマイク13との接続も無線でもよいこと、及び、前記「地図データベース」、「実況映像データベース」、これらの検索プログラム、及び地図データベース再生プログラムは、CD-ROM4から読み取るのではなく、前記中継サービス用コンピュータ11などのネットワーク上のサーバー(コンピュータ)から取り込むようにしてもよい。特に、上記のように、図1のパソコン1を移動中の自動車内で使用する場合(自分が自動車を運転しているとき、GPS受信機で受信した測位情報や各種のセンサにより得た測位情報から現在の位置を画面表示された地図上で求め、この「自分の現在位置に対応する実況地点

の実況映像で且つ自分の進行方向に対応する撮像方向の実況映像」を、パソコン1のディスプレイ7に表示させる場合は、前記パソコン1の制御装置2と前記中継サービス用コンピュータとの間は無線で送受信する必要がある。

【0019】実施形態2。次に、本発明の実施形態2を図1により説明する。図1において、1はユーザーが使用するパーソナルコンピュータ(パソコン)で、CPU及び通信モデム等より成る制御装置2と、コンピュータプログラム及びデータが記録されたハードディスク装置3と、コンピュータプログラム及びデータが記録されたCD-ROM4を駆動するためのCD-ROMドライブ5と、データ入力するためのキーボード6と、画像を出力するためのディスプレイ7と、音声を出力するためのスピーカ8とより、構成されている。前記制御装置2は、公衆回線10を介して、中継サービス用コンピュータ11に接続されている。この中継サービス用コンピュータ11には、多数の地点にそれぞれ設置されたビデオカメラ12及び集音マイク13が、コンピュータ(サーバー)14を介して、接続されている。これらの多数のビデオカメラ12及びマイク13等により入力された映像データ及び音声データは、ユーザーからの要求により、前記コンピュータ(サーバー)14及び中継サービス用コンピュータ11を介して、ユーザーに送信できるようになっている。また、図1の多数のビデオカメラ12及び集音マイク13は、識別データにより互いに識別できるようになっている。したがって、また、各ビデオカメラ12及び集音マイク13からの実況映像及び音声は、互いに識別できるようになっている。また、これらの多数のビデオカメラ12及びマイク13等により入力された映像データ及び音声データは、ユーザーからの要求により、中継サービス用コンピュータ11を介して、ユーザーがオンラインで閲覧できるようになっている(例えば、インターネット・ホームページ閲覧用ソフトウェアのブラウザを使用して、閲覧できるようになっている)。また、前記中継サービス用コンピュータ11は、他の多数の中継サービス用コンピュータ12などとも接続されており、例えば、中継サービス用コンピュータに接続されたユーザーは、この中継サービス用コンピュータ11を介して他の中継サービス用コンピュータ12などから、それに接続されたビデオカメラ及びマイクから入力されたデータを取り込めるようになっている。

【0020】この実施形態2では、前記CD-ROM4には、前記各地点(前記ビデオカメラ12及びマイク13が設置された各場所)の実況映像を識別するための映像識別データと多数のキーワードとを互いに関連付けた実況映像データベースと、これらのキーワードから前記映像識別データを検索するプログラムとが、記録されている。この実況映像データベースに記録されているキーワードには、地名、場所のジャンル(海岸、町角、港

町、山、交差点、建物、レストラン、劇場、映画館、スポーツ施設、野球場、温泉、寺院など)、行動のジャンル(スポーツ、演劇、映画、食事、散歩など)、などの様々なものが含まれている。今、例えば大阪に住んでいるユーザーが、「自分の故郷の神奈川県夏の湘南海岸の海岸線に沈む夕陽の景色を見たい」と考えたとする。その場合、例えば、ユーザーが前記キーボード6により「神奈川県、夏、湘南海岸、海岸線、夕陽」などのキーワードを入力すると、制御装置2は、これらの入力されたキーワードに基づいて、CD-ROM4に記録された実況映像識別データの中から対応するものを検索する。そして、この検索された実況映像識別データに基づいて、中継サービス用コンピュータ11にアクセスして、その識別データに対応する地点に設置されたビデオカメラ及びマイクからの映像データ及び音声データをリアルタイムに取り込んで、ディスプレイ7及びスピーカ8から出力することができる。このとき出力される映像及び音声は、現時点のリアルタイムの映像及び音声なので、ユーザーはあたかもその現場に実際にいるような感動を得ることができる。

【0021】また、同様に、この実施形態2では、ユーザーが例えば「寺院、京都」というキーワードを入力すれば、前記制御装置2がそれに該当する複数の映像識別データを検索し、それらを順次ディスプレイ7に表示する。また、例えば長期入院しているユーザーが、実際には行けないが「九州各地の温泉巡りをしてみたい」と思えば、「九州各地、温泉巡り」などのキーワードを入力すれば、前記制御装置2が、それに該当する複数の映像識別データを検索し、それらの識別データに対応する実況映像を受信して、順次ディスプレイ7に表示する。これは、ユーザーにとっては、実際には行っていないのに実際に行っているのと同じ感動を得ることができる。このように、この実施形態2は、ユーザーにとってあたかも旅行に行っていないのに行っているのと同様の感動を得られる「バーチャル・トラベル(仮想旅行)」を実現できるシステムであると言える。

【0022】また同様に、ユーザーが「横浜の港町を食べ歩きしたい」と思えば、「横浜、港町、食べ歩き」というキーワードを入力すれば、前記制御装置2がこれらのキーワードに基づいて対応する複数の映像識別データを検索し、これらに対応する複数の前記各地点からの実況映像のデータを取り込んでくれる(この場合、公衆への映像提供を承諾したレストランの内部に前記ビデオカメラとマイクを設置しておけば、その内部の状況、例えば客の今の混み具合や店内の雰囲気なども知ることができる)。また、同様に、ユーザーが「日本全国の劇場巡り(野球場巡り)をしてみたい」と思えば、「日本、劇場巡り(野球場巡り)」というキーワードを入力すれば、前記制御装置2がこれらのキーワードに基づいて対応する映像識別データを検索し、それらに対応する実況

映像をリアルタイムに出力してくれる。この場合、各劇場又は各野球場に、所定時間のみ劇の内容（又は試合内容）の送信を承諾してもらえば、ユーザーは所定時間のみではあるが、その劇（又は試合）の内容を言わばインデックス代わりに見ることができる。

【0023】実施形態3。次に、本発明の実施形態3を説明する。この実施形態3では、前記の実施形態1の構成に加えて、次のようなものが備えられている。まず、前記ビデオカメラ12やマイク13の近傍に備えられた匂い入力装置が備えられている。この匂い入力装置には、匂いセンサと、この匂いセンサからの信号を匂いのデジタルデータにコード化するコード化部が備えられている。前記匂いセンサは、既存の複数の匂いセンサから構成され、各センサからの匂い量検出値はすべて前記コード化部（エンコーダ）に供給される。コード化部（エンコーダ）では、この供給された匂い量検出値を符号化する。この符号化された匂いデータ（デジタルデータ）は、記録装置に記録されると共に、遠隔のユーザーが、コンピュータ通信ネットワークを介してリアルタイムに閲覧し取り込めるようになっている。なお、前記の匂いセンサは、感知できる匂いの種類毎に複数用意しておき、できるだけ現場の元の匂いを忠実に再現できるだけの情報を得られるようにすることが望ましい。次に、ユーザー側には、前記の閲覧し取り込んだ匂いデータ（デジタルデータ）を、現場の匂いに近似した匂いを発生させるための芳香剤調合データに変換する変換装置と、前記ディスプレイ7（図1）の近傍に備えられ、前記芳香剤調合データから芳香剤を調合して所望の匂いを発生させる匂い発生装置と、が備えられている。まず、前記の「前記閲覧し取り込んだ匂いデータ（デジタルデータ）」を、現場の匂いに近似した匂いを発生させるための芳香剤調合データに変換する変換装置を説明する。前記変換装置は、各匂いセンサの検出値のパターンを各芳香剤の出力値のパターンに変換する。より具体的には、様々な種類の匂いのそれぞれについて、その匂いを匂いセンサに検出させると検出値がどのような値をとるかを予め調査・記録しておく。そして、この匂いと匂いセンサの検出値パターンとの関係を記録したデータと、各匂いと芳香剤（の成分）との関係を記録したデータとから、各匂いセンサの検出値のパターンと複数種類の芳香剤の出力値のパターンとを対応付けて記録しておくようにする。前記変換装置は、この対応付けられた情報に基づいて、匂いセンサの検出値のパターンを芳香剤（の成分）の出力値のパターン（これが「芳香剤調合データ」となる）に変換するものである。このことをより詳細に述べると、次のとおりである。前記変換装置には、各匂いを匂いセンサで検出したときの匂いセンサの検出値と、その匂いを後述の匂い発生装置で発生させるときの各芳香剤の出力値との対応関係が記録されたセンサ芳香剤量変換テーブルが、予め記録されている。そして、変換装置

は、前記匂いセンサの検出値データに基づいて、このセンサ芳香剤量変換テーブルを参照して、各匂いセンサ毎の検出値を各芳香剤毎の出力値に変換する。

【0024】次に、前記の「前記芳香剤調合データから芳香剤を調合して所望の匂いを発生させる匂い発生装置」を説明する。匂い発生装置は、予め複数種類の芳香剤を用意しておき、前記の「芳香剤調合データ」（前記の芳香剤出力パターンデータ。各芳香剤からの匂い成分をとれだけ発生させるかを示すデータ）に基づいて、必要な種類の匂いの成分（芳香剤からの成分）を必要な分量だけ発生させる。匂い発生装置の形態としては、ある空間中においてその空間全体に匂いを行き渡らせる据置型のもので、ユーザーの鼻の付近又は鼻の中に装着して装着した人への匂いを感得させる個人携帯型のもので、考えられる。例えば、前記の据置型のものとしては、次のようなものが考えられる。すなわち、箱の底に芳香剤の入った容器を並べて、芳香剤と空気とが接する面積を任意に調整できる蓋を各容器に付けておき、箱の後ろ側には、必要に応じて送風機を設ける。そして、前記の「芳香剤出力パターン」のデータに応じて、各芳香剤の成分を所定量ずつ放出できるように、対応する各芳香剤の容器の蓋の開閉具合を調節する。また、前記携帯型のものについては、基本的構成は据置型のもと同様でよいが、これを小型化し、これをヘルメット型、ヘッドセット型、メガネ型、マスク型などの頭部支持具によりユーザーの鼻の付近に装着できるようにする。なお、この実施形態3では、前記の「前記閲覧し取り込んだ符号化された匂いデータ」を、現場の匂いに近似した匂いを発生させるための芳香剤調合データに変換する変換装置をユーザー側のパソコン1側に備えるようにしているが、本発明ではこれに限られるものではなく、例えば、現場のビデオカメラ12やマイク13が設置された地点に備えるようにしてもよいし、コンピュータ・ネットワーク上の中継サービス用コンピュータ（サーバー）11に備えるようにしてもよい。また、以上の実施形態3で説明した「匂いのデータ化、記録、通信、及び再生」の技術は、例えば特開平7-55742号公報などに開示された公知の技術である。

【0025】実施形態4。図5は本発明の実施形態4を示すブロック図である。図5において、21は液晶ディスプレイ（LCD）である。また図5において、22は従来より市販されているGPS（Global Positioning System）受信機で、人工衛星からの電波の遅延時間を計測し、軌道からの距離からユーザーの現在位置を求めるためのものである。このGPS受信機22は、人工衛星から送信されるGPS電波を受信するGPS受信アンテナと、このGPS電波から現在位置を緯度データ及び経度データとして認識する位置認識部（CPUにより構成される）を含んでいる。前記GPSアンテナは、GPS衛星からの例えば1.5GH

zの電波を受信し、その信号を前記位置認識部に送る。前記位置認識部では、稼働中のGPS衛星のうち受信可能な4個以上の衛星の電波を受信し、既知である衛星の位置と受信電波とから算出した各衛星-受信点間の距離とを基にして、受信点の現在位置を取得し、緯度データ及び経度データを算出する。なお、以上のGPS受信機2の詳細な構成及び使用方法は従来より公知である(例えば、特開平5-45171号公報、特開平7-306054号公報、特開平8-94735号公報などを参照)ので、詳細な説明は省略する。また、図5において、26は進行方向入力部で、ユーザーが徒歩、車両、鉄道などにより移動中のときのその進行方向(東西南北など)を地磁気などを利用して計測しその進行方向を求める進行方向入力部である。この実施形態4では、前記GPS受信機22と進行方向入力部26とにより、本発明によるユーザーの「現在位置特定手段」を構成している。また図5において、23はこのGPS受信機22からの現在位置情報としての座標データ(緯度データ及び経度データ)と前記進行方向入力部26からの進行方向データを受け取り、該当する衛星画像を選択し、それを前記LCD21に表示するための制御部で、パーソナル・コンピュータなどにより構成されている。

【0026】また、図5において、24は、前記制御部23とインターネットなどのコンピュータ通信用公衆回線網20を介して接続された地図データベース用サーバー(コンピュータ)である。この地図用サーバー24は、例えば日本全国の地図を、座標データ(緯度データ及び経度データ)、地名、施設名、施設の識別データ(施設の電話番号など)などの位置識別データと関連付けながら、データベースとして記録している。この地図用サーバー24は、公衆回線網20により前記制御部23とオンラインで接続されている。なお、この公衆回線網20は、有線通信網だけでなく、携帯電話網、PHS(パーソナル・ハンディホン・システム)網、自動車電話網及び人工衛星通信網などの無線通信網をも含むものであることが望ましい。

【0027】また図5において、25は、インターネットなどのコンピュータ通信用公衆回線網20に接続された実況映像入力装置で、各実況地点それぞれ設けられ、各実況地点における複数方向の実況映像(各実況地点から複数方向に向かって見える実況映像)をそれぞれリアルタイムに常時入力する複数のデジタル・ビデオカメラと、これらのデジタル・ビデオカメラからのデジタル映像データを、インターネットなどのコンピュータ通信網を介してアクセスして来た複数のユーザーに対してオンラインで提供するための実況映像提供用コンピュータと、から構成されている。この実況映像提供用コンピュータは、各地点の実況映像を、座標データ(緯度データ及び経度データ)、地名、施設名、施設の識別データ(施設の電話番号など)などの位置識別データ及び東西

南北などの方向データと関連付けながら、データベースとして記録している。この実況映像提供用コンピュータは、前記通信網20により前記制御部23とオンラインで接続されている。なお、この通信網20は、有線通信網だけでなく、携帯電話網、PHS(パーソナル・ハンディホン・システム)網、自動車電話網及び人工衛星通信網などの無線通信網をも含むものであることが望ましい。

【0028】制御部23は、ユーザーのキーボード26又はマウス27などの入力装置による指示により、前記地図用サーバー24にアクセスして、そこから、ユーザーが希望する地点(前記入力装置で指定した地点)を含む所定領域の地図のデータをオンラインで取り出して、LCD21に表示させる。また、前記制御部23は、ユーザーがこの表示された地図の任意の地点をマウス27で指示しその地点を含む所定領域の実況映像の表示を指令したとき、前記各実況地点の前記実況映像提供用コンピュータを含む映像入力装置25にアクセスして、該当する所定領域の実況映像のデータをオンラインで取り出して、その実況映像をLCD21にリアルタイムに表示させる。また、制御部23は、ユーザーが、例えば、表示を希望する地点の地名、施設名、施設の識別データなどを入力して該当する実況地点の実況映像又はその実況地点を含む地図の表示を希望したとき、前記映像入力装置25又は地図用サーバー24にアクセスして、該当する実況映像又は地図をオンラインで取り出して、それらをLCD21に表示させる。また、制御部23は、ユーザーが自分が現在居る現在地点から進行方向に向かう方向で且つ最も近くの場所にある実況地点の実況映像であって、その進行方向に向かって見える実況映像を表示せよと指令したときは、前記GPS受信機22及び進行方向入力部26からユーザーの現在位置及び進行方向を座標データ(緯度データ及び経度データ)及び方向データとして受け取り、その座標データ及び方向データに基づいて、該当する前記各実況地点の映像入力装置25にアクセスして、オンラインで該当の実況映像の提供を受けて、LCD21に表示させる。なお、この場合の、前記制御部23が前記映像入力装置25から該当する実況映像の提供を受ける方法としては、従来のインターネット用のブラウジング・ソフトウェア(閲覧ソフトウェア)などによりこの各地の映像入力装置25にそれぞれ直接アクセスして取り込む方法と、前記映像入力装置25に対して該当する実況映像データを電子メールに添付したファイルとして送信してもらうように依頼してその送信により受け取る方法など、様々な方法が有り得る。

【0029】また、この実施形態4では、前記制御部23は、ユーザーが、ある実況映像が前記LCD21に表示されているとき、その表示された実況映像の中のある部分だけを、例えば特定の建築物や特定の橋や特定の道路などの部分だけを、他の部分と見分けやすいように所

定のマーキングをしたいと指令したときは、その部分を他と異なって目立つようにマーキングできる手段（プログラム）を含むのがよい。この場合のマーキングは、例えば、他と異なる色で着色して色別する方法、その部分のみに網掛け処理を行う方法、その部分を他の部分よりも太い実線で表示する方法、などの様々な方法がある。

【0030】実施形態5。次に、図6は本発明の実施形態5を示すブロック図である。図6において、符号21、22、23、26、27は図1におけると同様なので説明を省略する。図6において、34は制御部23に接続されたCD-ROMプレーヤ（再生装置）、35はこのCD-ROMプレーヤ34に読み取られるCD-ROMである。このCD-ROM35には、例えば日本国の全体の地図を、座標データ（緯度・経度データ）、地名、施設名、施設識別データなどの位置識別データと関連付けて記録した地図データベースが記録されている。また図6において、31は、インターネットなどのコンピュータ通信網30に接続された映像入力装置で、図4の映像入力装置25と同様のものである。前記制御部3は、前記CD-ROMプレーヤ14によりCD-ROM15を読み取ることにより、ユーザーが希望する位置を含む所定領域の地図を読み取ってLCD1に表示させることができる。また、前記制御部3は、前記コンピュータ通信網30を介して映像入力装置31にアクセスすることにより、ユーザーが希望する実況地点からのユーザーが希望する所定方向の実況映像を取り込み、LCD21に表示させることができる。また、制御部23は、ユーザーが、「自分が現在居る現在地点から進行方向に向かう方向にある地点で且つ現在地点から最も近い実況地点の実況映像であって、その地点から自分の進行方向に向かって撮像した実況映像を、表示せよ」と指令したときは、前記GPS受信機22からユーザーの現在位置を座標データ（緯度データ及び経度データ）として受け取り、且つ、前記進行方向入力部26からユーザーの進行方向のデータを受け取り、その座標データ及び進行方向データに基づいて、前記映像入力装置31にアクセスして、該当の座標データに近い場所にある実況地点のもので且つユーザーの進行方向に近い方向の実況映像のデータをオンラインで読み取り、その実況映像をリアルタイムにLCD21に表示させる。

【0031】

【発明の効果】

(1)本発明による実況映像提供システムによれば、ユーザーは、地図を見ながら、例えば希望の地点をポインティングデバイスで指定する（例えばマウスでクリックする）だけで、その地点の今の現時点の状況を実況映像で見ることができる。また、ユーザーは、いちいちポインティングデバイスで指定しなくても、予めコンピュータプログラムで実況映像を希望する複数の地点の地点識別データを順次入力するようになっておけば、コンピュータ

により次々と希望する地点に対応する実況映像を表示させることができる。よって、ここでも、ユーザーは地図を見ながら、実際には行っていないのに実際に行っているのと同じ感動を得られる「バーチャル・トラベル（仮想旅行）」を実現できるようになる。また、例えば、全世界の地図から全世界の各地の実況映像をみながら、全世界のユーザーが一つの宝を探していくというような、コンピュータ通信ネットワークの世界の中での「宝探し」ゲームを世界中で同時に競うことも可能になる。また従来より存在しているGPS受信機と請求項1の発明とを組み合わせることで、次のような効果を得ることができる。すなわち、ユーザーがGPS受信機からの現在位置（緯度データと経度データの座標データ）に基づいて地図データベースから現在位置を含む所定領域の地図を読み出して表示し、その表示された地図上に表示された現在位置（座標データ）又はそれと近い地点をユーザーがマウスでクリックしてその地点の実況映像をオンラインで取り出すように指令すれば、GPS受信機からの現在位置が計測誤差などがなく正しいものかどうかを確認できる。つまり、表示された実況映像がユーザーの現在の位置から実際に見えるものと一致していれば、GPS受信機からの現在位置は正しいものと判定できる（従来は、ユーザーは、地図だけでは、GPS受信機による現在位置が正しいかどうかを自分で確かめることが困難だった）。

(2)また、本発明による実況映像提供システムによれば、ユーザーは、ある地点の実況映像を見ながら、その実況映像の識別データから、対応する地図上の地点を表示させることができるので、ある実況映像を見て、その実況映像が見える場所が地図上のどこなのか（どうい地名・施設名なのかなど）を、容易に知ることができるようになる。

(3)また本発明による実況映像提供システムによれば、ユーザーは、自分の希望する文字列等により構成される検索データを入力することにより、その検索データに対応する一つ又は複数の地点の実況映像を、その場でリアルタイムに見ることが可能になる。特に、遠隔の複数の地点における今この瞬間の実況を映像でリアルタイムに順次見ることができる「バーチャル・トラベル（仮想旅行）」を提供できるようになる。

(4)なお、本発明において、前記各実況映像を特定するための実況映像識別データを、前記映像入力手段が撮影した方向を示す方向データとから構成するようにすれば、同じ地点でも、見る方向によって異なる実況映像を提供できるようになり、「生の現場」をより詳細にリアルタイムに再現できる実況映像を提供できるようになる。

(5)また本発明では、ユーザーの現在位置をGPS受信機などの現在位置特定手段により求め、この求められた

現在位置に対応する実況地点の実況映像をオンラインで取り出して表示するようにしている。したがって、ユーザーは、例えば、次のような使い方が可能になる。例えば、自分が車両などに乗って移動しているとき、GPS受信機により自分の現在位置を求めて、その現在位置に対応する地図上の地点を地図画面上で見る（このためのシステムは、従来より、自動車用の目的地までのルート地図探索・運転案内システムとして実用化されている）。また、同時に、ユーザーは、GPS受信機からの現在位置を求め、通信ネットワークを介して該当する映像入力手段にアクセスし、現在位置に対応する実況映像をオンラインで取り出して画面上に表示させて見る。これにより、ユーザーは、目的地へのルートを記載した地図を見ながら、地図上に表示されている現在位置（GPS受信機により計測されるユーザーの現在位置が画面の地図上に矢印などで表示されるシステムは自動車の運転案内システムとして既に多数市販されている）と実況映像とが一致しているかどうかを確認し、一致していれば、GPS受信機からの現在位置が計測誤差なく正しいことを確認できる。また一致していなければ、GPS受信機からの現在位置が間違っていることが分かる。なお、ここで述べた請求項5の発明によらずとも、従来より存在しているGPS受信機と請求項1の発明とを組み合わせることによっても、請求項5と同様の効果を得ることはできる（上述のとおり）。すなわち、ユーザーがGPS受信機からの現在位置に基づいて地図データベースから現在位置を含む所定領域の地図を読み出して表示し、その表示された地図の現在位置に近い地点をマウスでクリックし、そのマウスでクリックした地点に近い一つ又は複数の実況地点の実況映像をオンラインで取り出すようにすれば、GPS受信機からの現在位置が正しいかどうかをユーザー自身が確認できる。

(6)また、本発明では、前記映像入力手段は、前記各実況地点から複数の方向に向かって見える映像を撮像するものであり、前記各実況地点を互いに識別するための実況地点識別データは、前記映像入力手段が設けられた各実況地点の位置を示す位置データとその映像入力手段が撮影する方向を示す方向データとから構成されており、前記現在位置特定手段は、ユーザーの現在位置を特定する手段とユーザーの進行方向を特定する手段とを含んでおり、前記実況地点識別データ選択手段は、前記現在位置特定手段により特定されたユーザーの現在位置（緯度データ及び経度データによる座標データなど）及びユーザーの進行方向（東西南北など）に基づいて、ユーザーの現在位置に（最も）近い実況地点を示し且つユーザーの進行方向に（最も）近い方向の実況地点識別データを選択するものである。よって、車両などで移動中のユーザーは、画面に表示された地図上の自分の現在位置（GPS受信機からの自分の現在位置が矢印などで表示される）を見ながら、同時に、前記GPS受信機からの現在

位置に対応する実況映像を見ることができ、地図上の地点と実況映像とを照らし合わせて、GPSにより計測された地図上の現在位置が本当に正しいかどうかを確認することができる。

(7)また、本発明では、前記表示手段に表示された実況映像の中のユーザーが指定した部分に対して他の部分と区別するためのマーキングをするためのマーキング手段を備えることにより、実況映像（動画でも静止画でもよい）の中のある部分（例えば、特定の建築物、橋、道路、河川、公園など）のみをマーキングできるので、実況映像を自分の目的に応じて見やすい形に加工できるようになる。

(8)また、本発明において、前記映像入力手段に、その地点において発生している音声をリアルタイムに入力する手段をも含ませ、これらの入力された音声をそれぞれリアルタイムに無線又は有線で取り込む（インターネット用ブラウザによる閲覧する場合や通信ネットワークにより送信させる場合などを含む）ことにより、ユーザーは、実況映像（現場の生の映像、動画又は静止画）だけでなく、「現場の生の音声」をも併せて知ることが可能になる。

(9)また本発明では、さらに、前記映像入力手段の近傍に備えられ、匂いセンサと、この匂いセンサからの信号を匂いデジタルデータに変換する手段とから構成され、前映像入力手段の設置された地点又はその周辺の匂いを入力するための匂い入力手段と、この匂い入力手段からの匂いデータを、その匂いに近似した匂いを発生させるための芳香剤調合データに変換する手段と、前記表示手段の近傍に備えられ、前記芳香剤調合データから芳香剤を調合して所望の匂いを発生させる匂い発生手段と、を含むようにすることにより、ユーザーは、前記の実況映像と実際の音声だけでなく、現場の実際の匂いをも、リアルタイムに遠隔地において感得することができるようになる。

【図面の簡単な説明】

【図1】 本発明の実施形態1又は2のハードウェア構成を示す図である。

【図2】 本発明の実施形態1又は2の概念的構成を示す図である。

【図3】 本発明の実施形態1のディスプレイの構成を示す図である。

【図4】 本発明の実施形態1においてディスプレイに表示される地図の一例を示す図である。

【図5】 本発明の実施形態4を示すブロック図である。

【図6】 本発明の実施形態5を示すブロック図である。

【符号の説明】

- 1 パーソナルコンピュータ（パソコン）
- 2 制御装置