

(54) **SYSTEM AND METHOD FOR PROVIDING A MUSICAL RINGING TONE ON MOBILE STATIONS**

(75) Inventors: **Janette Chen Lin**, Dallas; **David Boltz**, Garland; **Walt Evanyk**, Plano, all of TX (US)

(73) Assignee: **Ericsson Inc.**, Research Triangle Park, NC (US)

(\*) Notice: Subject to any disclaimer, the term of this patent is extended or adjusted under 35 U.S.C. 154(b) by 0 days.

(21) Appl. No.: **09/336,427**

(22) Filed: **Jun. 17, 1999**

(51) **Int. Cl.**<sup>7</sup> ..... **H04B 1/38**

(52) **U.S. Cl.** ..... **455/567; 455/466; 455/412; 379/373.01; 379/373.02; 379/373.04**

(58) **Field of Search** ..... **455/403, 412, 455/414, 418, 433, 466, 567; 379/373.01-373.05**

(56) **References Cited**

**U.S. PATENT DOCUMENTS**

4,866,766 A \* 9/1989 Mitzlaff ..... 379/373.02

4,868,561 A \* 9/1989 Davis ..... 379/373.02  
5,452,354 A \* 9/1995 Kyronlahti et al. .... 379/373.02  
5,724,411 A \* 3/1998 Eisdorfer et al. .... 379/373.02  
5,870,683 A \* 2/1999 Wells et al. .... 455/566  
5,987,323 A \* 11/1999 Huotari ..... 455/433  
6,094,587 A \* 7/2000 Armanto et al. .... 455/566  
6,138,006 A \* 10/2000 Foti ..... 455/414

\* cited by examiner

*Primary Examiner*—William Trost

*Assistant Examiner*—Simon Nguyen

(74) *Attorney, Agent, or Firm*—Jenkins & Gilchrist, P.C.

(57) **ABSTRACT**

A telecommunications system and method is disclosed for allowing network operators to download ringing tone pattern (s) associated with one or more musical scores to mobile stations (MSs) according to the music selection of mobile subscribers associated with the MSs. Once executed, the ringing tone pattern provides a musical ringing tone on the MS, instead of the normal ringing tone. In addition, ringing tone patterns can be used to enhance the “distinctive ringing” function within the MS. Thus, instead of using distinctive ringing patterns to represent different called party numbers, different music can be used.

**31 Claims, 5 Drawing Sheets**

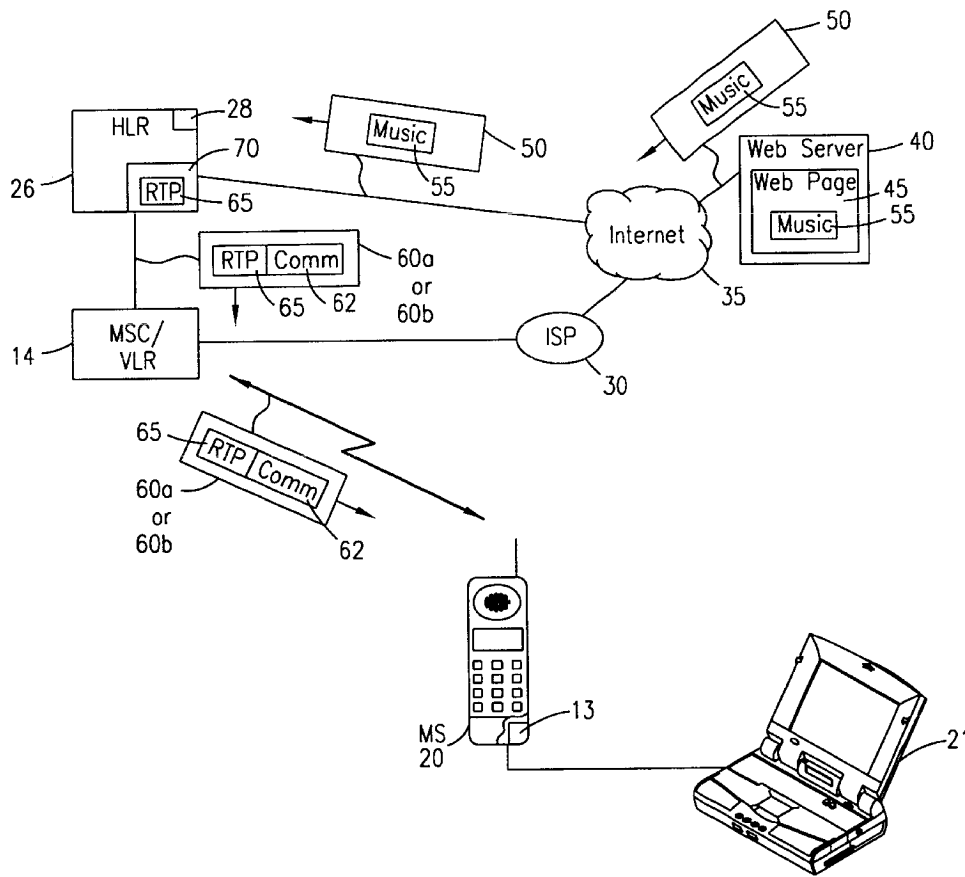

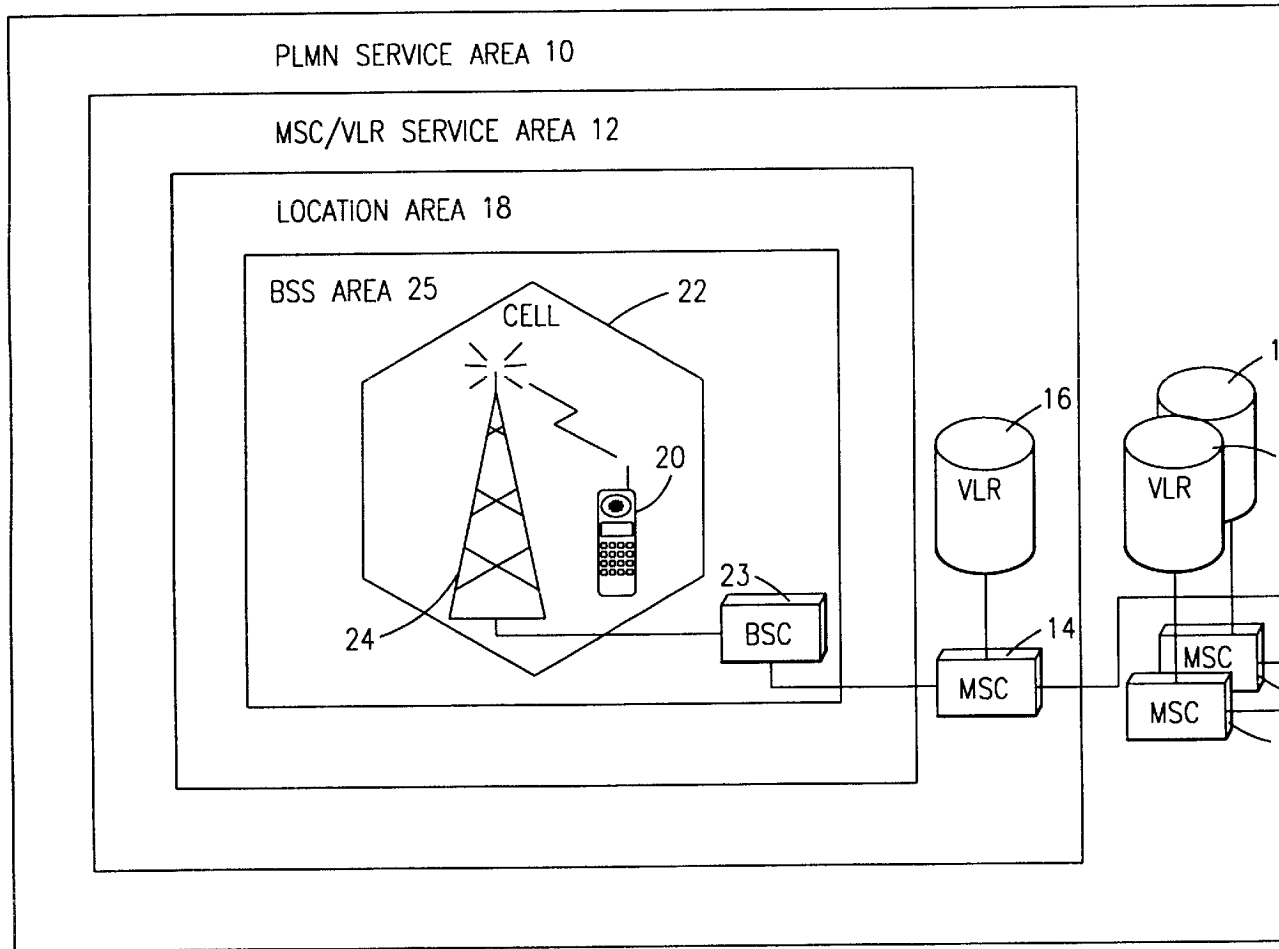

FIG. 1

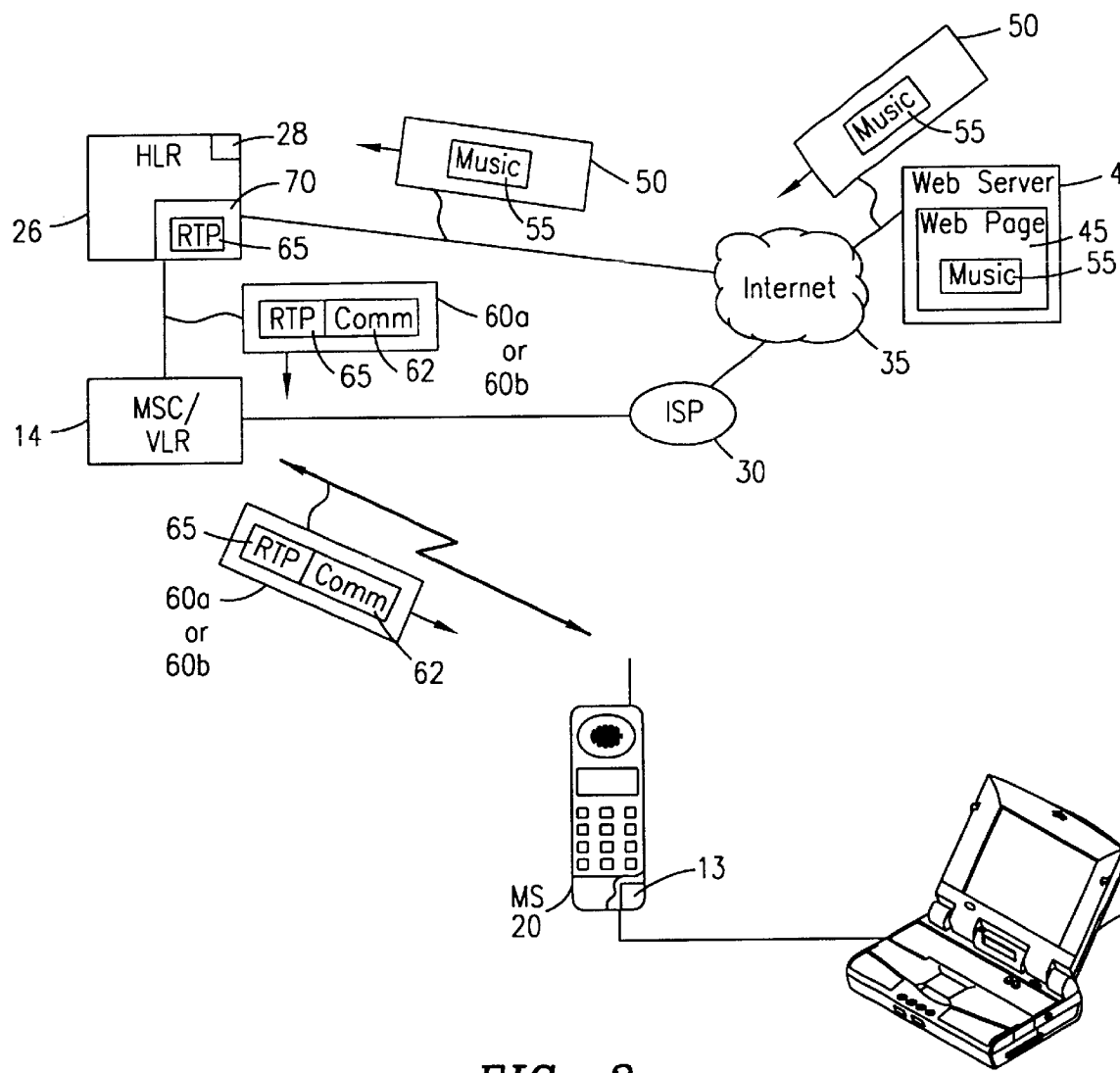
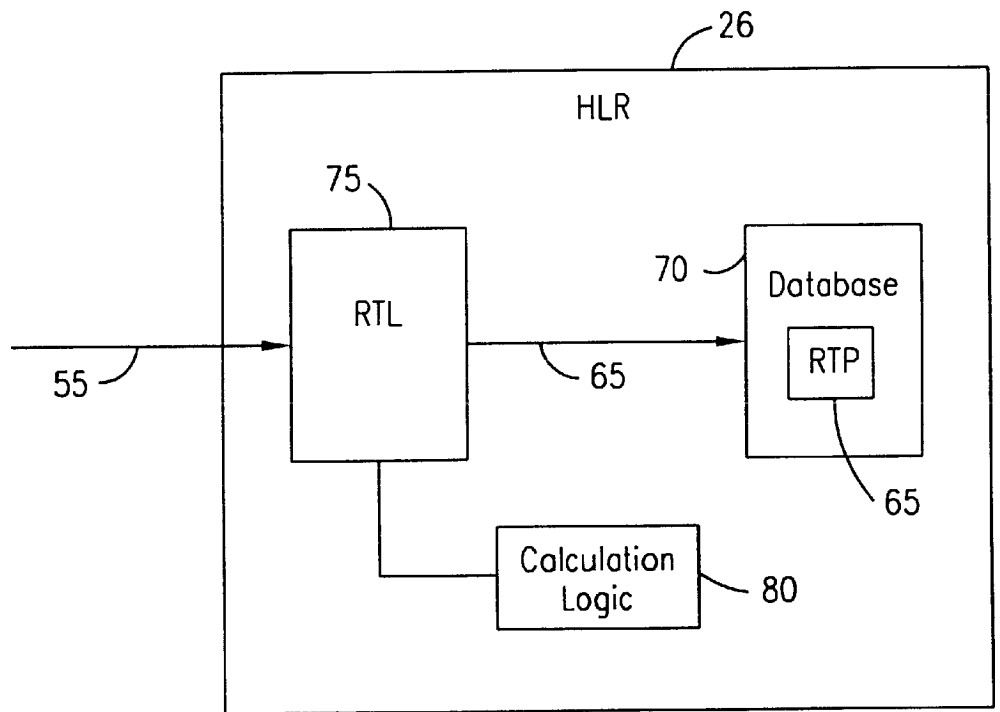

FIG. 2



*FIG. 3*

Musical Ringing Tone Database in HLR

55

74

Phone Model	Music	Ring tone programming pattern
Ericsson DF380	Titanic	X-A-3--3-2---1-1-2-2--5-7----B-7-6-6-Z
Ericsson AF780	Titanic	X-A-B-3--3-2---1-1-2-2--5-7----A-B-7-6-
...	...	.....
Ericsson AF880	Walking in the Rain	X-A---1-2-1-3-7-7--5-4----D-7-3-6-U

72                      76                                      78

FIG. 4

# Explore Litigation Insights

Docket Alarm provides insights to develop a more informed litigation strategy and the peace of mind of knowing you're on top of things.

## Real-Time Litigation Alerts



Keep your litigation team up-to-date with **real-time alerts** and advanced team management tools built for the enterprise, all while greatly reducing PACER spend.

Our comprehensive service means we can handle Federal, State, and Administrative courts across the country.

## Advanced Docket Research



With over 230 million records, Docket Alarm's cloud-native docket research platform finds what other services can't. Coverage includes Federal, State, plus PTAB, TTAB, ITC and NLRB decisions, all in one place.

Identify arguments that have been successful in the past with full text, pinpoint searching. Link to case law cited within any court document via Fastcase.

## Analytics At Your Fingertips



Learn what happened the last time a particular judge, opposing counsel or company faced cases similar to yours.

Advanced out-of-the-box PTAB and TTAB analytics are always at your fingertips.

## API

Docket Alarm offers a powerful API (application programming interface) to developers that want to integrate case filings into their apps.

## LAW FIRMS

Build custom dashboards for your attorneys and clients with live data direct from the court.

Automate many repetitive legal tasks like conflict checks, document management, and marketing.

## FINANCIAL INSTITUTIONS

Litigation and bankruptcy checks for companies and debtors.

## E-DISCOVERY AND LEGAL VENDORS

Sync your system to PACER to automate legal marketing.