

EXHIBIT

DSS-2005



US007092762B1

(12) **United States Patent**
Loftin et al.

(10) **Patent No.:** **US 7,092,762 B1**
(45) **Date of Patent:** **Aug. 15, 2006**

(54) **LOW-POWER, HIGH-MODULATION-INDEX AMPLIFIER FOR USE IN BATTERY-POWERED DEVICE**

(75) Inventors: **Scott M Loftin**, Simi Valley, CA (US);
Kelly H McClure, Simi Valley, CA (US)

(73) Assignee: **Advanced Bionics Corporation**,
Valencia, CA (US)

(*) Notice: Subject to any disclaimer, the term of this patent is extended or adjusted under 35 U.S.C. 154(b) by 613 days.

(21) Appl. No.: **10/445,121**

(22) Filed: **May 23, 2003**

Related U.S. Application Data

(62) Division of application No. 09/945,303, filed on Aug. 31, 2001, now Pat. No. 6,591,139.

(60) Provisional application No. 60/230,399, filed on Sep. 6, 2000.

(51) **Int. Cl.**
A61N 1/02 (2006.01)
H04B 5/00 (2006.01)

(52) **U.S. Cl.** **607/60; 607/156; 607/32; 128/903; 128/902**

(58) **Field of Classification Search** **607/60, 607/32, 156, 61; 128/902, 903; 340/870.01; 455/41.1, 41.2**

See application file for complete search history.

(56) **References Cited**

U.S. PATENT DOCUMENTS

- 4,223,679 A 9/1980 Schulman et al.
- 4,441,210 A * 4/1984 Hochmair et al. 455/41.1
- 4,571,589 A 2/1986 Slocum et al.
- 5,193,539 A 3/1993 Schulman et al.
- 5,193,540 A 3/1993 Schulman et al.
- 5,697,076 A 12/1997 Troyk et al.

- 5,741,316 A 4/1998 Chen et al.
- 5,766,232 A 6/1998 Grevious et al.
- 5,948,006 A 9/1999 Mann
- 6,047,214 A 4/2000 Mueller et al.
- 6,073,050 A 6/2000 Griffith
- 6,099,479 A 8/2000 Christopherson et al.
- 6,163,721 A 12/2000 Thompson
- 6,185,452 B1 2/2001 Schulman et al.

FOREIGN PATENT DOCUMENTS

- WO WO 98/43700 8/1998
- WO WO 98/37926 9/1998
- WO WO 98/43701 10/1998

* cited by examiner

Primary Examiner—Kennedy Schaetzle

(74) *Attorney, Agent, or Firm*—Bryant R. Gold; Victoria A. Poissant

(57) **ABSTRACT**

An external transmitter circuit drives an implantable neural stimulator having an implanted coil from a primary coil driven by a power amplifier. For efficient power consumption, the transmitter output circuit (which includes the primary coil driven by the power amplifier inductively coupled with the implanted coil) operates as a tuned resonant circuit. When operating as a tuned resonant circuit, it is difficult to modulate the carrier signal with data having sharp rise and fall times without using a high power modulation amplifier. Sharp rise and fall times are needed in order to ensure reliable data transmission. To overcome this difficulty, the present invention includes an output switch that selectively inserts a resistor in the transmitter output coil circuit in order to de-tune the resonant circuit only during those times when data modulation is needed. Such de-tuning allows sharp rise and fall times in the data modulation without the need for using a high power modulation amplifier. Because data modulation is typically needed for only a small percent of the time that a carrier signal is present, it is thus possible using the present invention to achieve reliable data modulation, transmission and reception without having to use a high power modulation amplifier in the transmitter.

7 Claims, 4 Drawing Sheets

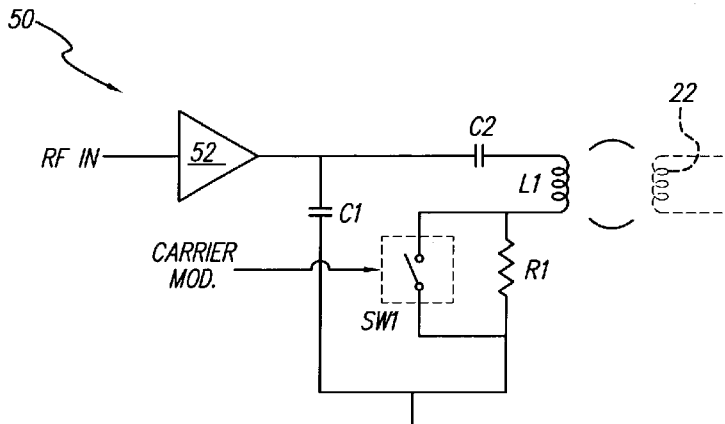

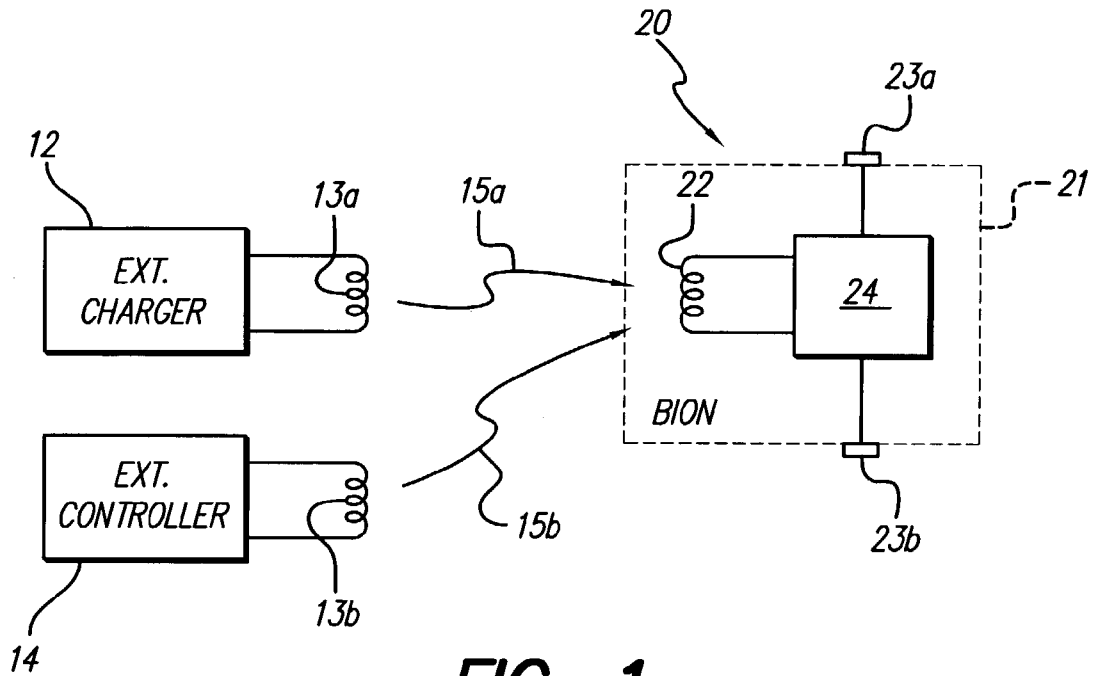

FIG. 1

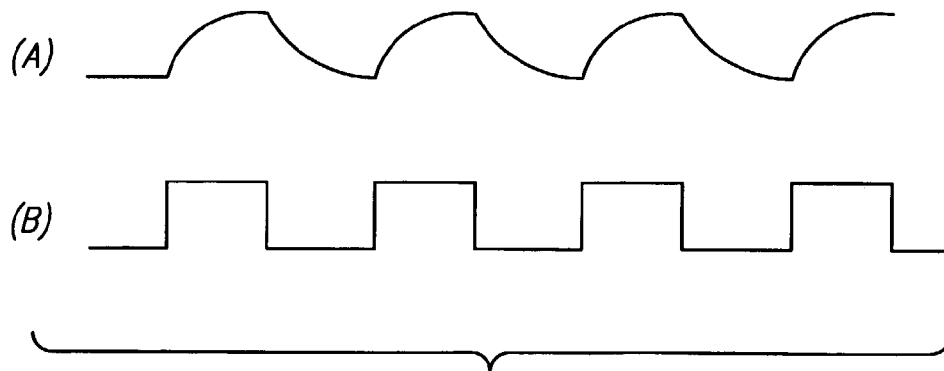

FIG. 3

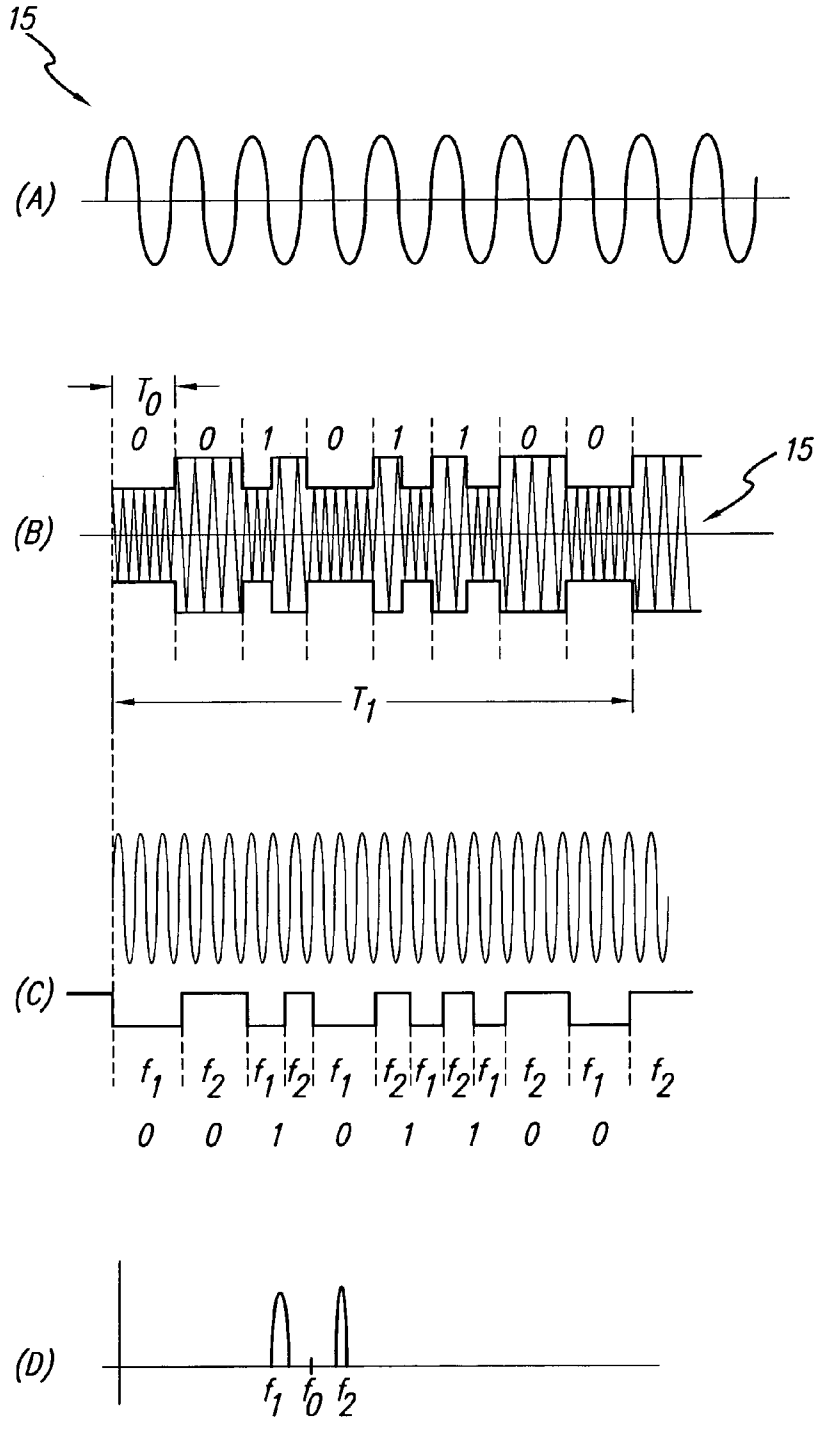

FIG. 2

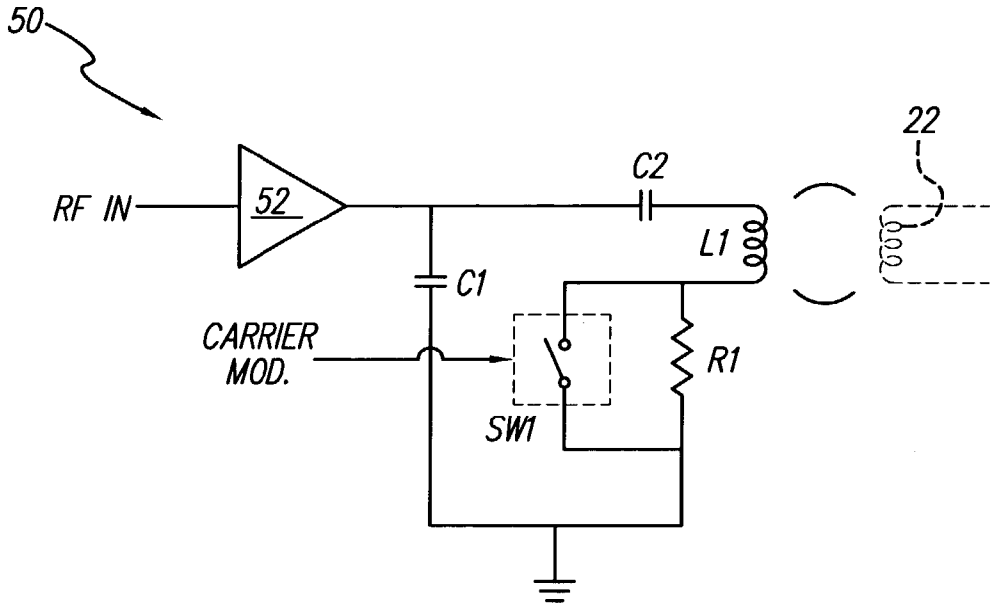

FIG. 4A

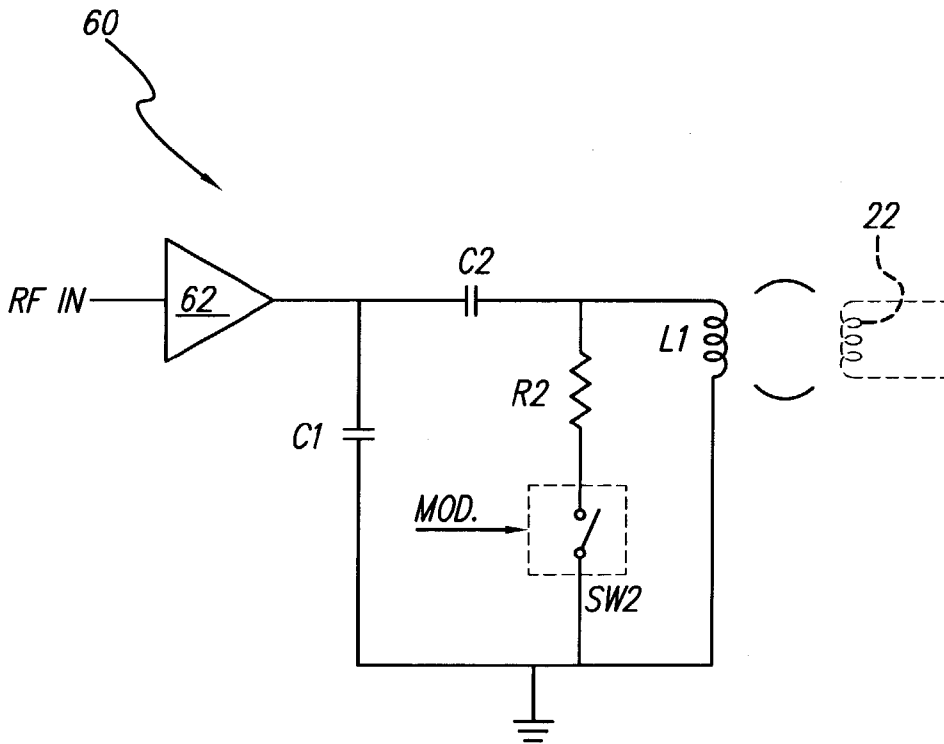

FIG. 4B

Explore Litigation Insights

Docket Alarm provides insights to develop a more informed litigation strategy and the peace of mind of knowing you're on top of things.

Real-Time Litigation Alerts



Keep your litigation team up-to-date with **real-time alerts** and advanced team management tools built for the enterprise, all while greatly reducing PACER spend.

Our comprehensive service means we can handle Federal, State, and Administrative courts across the country.

Advanced Docket Research



With over 230 million records, Docket Alarm's cloud-native docket research platform finds what other services can't. Coverage includes Federal, State, plus PTAB, TTAB, ITC and NLRB decisions, all in one place.

Identify arguments that have been successful in the past with full text, pinpoint searching. Link to case law cited within any court document via Fastcase.

Analytics At Your Fingertips



Learn what happened the last time a particular judge, opposing counsel or company faced cases similar to yours.

Advanced out-of-the-box PTAB and TTAB analytics are always at your fingertips.

API

Docket Alarm offers a powerful API (application programming interface) to developers that want to integrate case filings into their apps.

LAW FIRMS

Build custom dashboards for your attorneys and clients with live data direct from the court.

Automate many repetitive legal tasks like conflict checks, document management, and marketing.

FINANCIAL INSTITUTIONS

Litigation and bankruptcy checks for companies and debtors.

E-DISCOVERY AND LEGAL VENDORS

Sync your system to PACER to automate legal marketing.