

UNITED STATES PATENT AND TRADEMARK OFFICE

---

BEFORE THE PATENT TRIAL AND APPEAL BOARD

---

APPLE INC.,  
Petitioner,

v.

DSS TECHNOLOGY MANAGEMENT, INC.,  
Patent Owner.

---

Case IPR2015-00369  
Patent 6,128,290

---

Before JAMESON LEE, MATTHEW R. CLEMENTS, and  
CHARLES J. BOUDREAU, *Administrative Patent Judges*.

BOUDREAU, *Administrative Patent Judge*.

DECISION  
Institution of *Inter Partes* Review  
37 C.F.R. § 42.108

## I. INTRODUCTION

On December 4, 2014, Petitioner Apple Inc. (“Apple”) filed a Petition (Paper 1, “Pet.”) requesting *inter partes* review of claims 1–4 of U.S. Patent No. 6,128,290 (Ex. 1001, “the ’290 patent”). On March 30, 2015, Patent Owner DSS Technology Management, Inc. (“DSS”) timely filed a Preliminary Response (Paper 8, “Prelim. Resp.”). We have jurisdiction under 35 U.S.C. § 314, which provides that *inter partes* review may not be instituted “unless . . . there is a reasonable likelihood that the petitioner would prevail with respect to at least 1 of the claims challenged in the petition.” 35 U.S.C. § 314(a). Upon consideration of the Petition, Preliminary Response, and the proffered evidence, we conclude that Apple has established a reasonable likelihood that it would prevail in challenging the patentability of claims 1–4 of the ’290 patent under 35 U.S.C. § 103(a) on one of the grounds presented. Accordingly, we institute *inter partes* review of those claims.

### A. Related Matters

The parties inform us that the ’290 patent is the subject of two district court actions: *DSS Technology Management, Inc. v. Apple, Inc.*, No. 5:14-cv-05330-LHK (N.D. Cal.), and *DSS Technology Management, Inc. v. Lenovo (United States), Inc.*, No. 6:14-cv-00525-JDL (E.D. Tex.). Pet. 3–4; Paper 4, 2. Additionally, claims 6, 7, 9, and 10 of the ’290 patent are the subject of a concurrently filed petition for *inter partes* review, IPR2015-00373.

### B. The ’290 Patent (Ex. 1001)

The ’290 patent, titled “Personal Data Network,” issued October 3, 2000, from U.S. Patent Application No. 08/949,999 (Ex. 1005, 22–62, “the

'999 application"). The '999 application was filed October 14, 1997, as a continuation-in-part ("CIP") of U.S. Patent Application No. 08/611,695 (Ex. 1006, 21-61, "the '695 application"), filed March 6, 1996, which matured into U.S. Patent No. 5,699,357 (Ex. 2001, "the '357 patent"). See Ex. 1001, col. 1, ll. 6-8.

The '290 patent relates to a data network for bidirectional wireless data communications between a host or server microcomputer unit and a plurality of peripheral units referred to as personal electronic accessories (PEAs). Ex. 1001, col. 1, ll. 11-14, col. 2, ll. 15-18. Among the objects of the invention is the provision of a data network that requires extremely low power consumption, "particularly for the peripheral units," avoids interference from nearby similar systems, and is of relatively simple and inexpensive construction. *Id.* at col. 1, ll. 33-34, 39-45. Figure 1 of the '290 patent, reproduced below, is illustrative of the described wireless data network system.

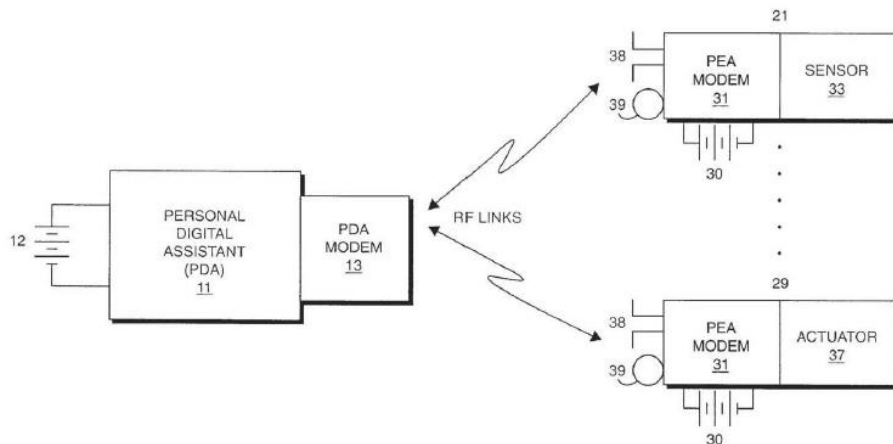

FIG. 1

Figure 1 is a block diagram of a wireless data network system linking a server microcomputer, referred to as “personal digital assistant (PDA) 11,” with a plurality of peripheral units, or PEAs, 21–29. *Id.* at col. 2, ll. 42–44, col. 2, l. 66–col. 3, l. 15.

According to the ’290 patent, “the server microcomputer unit and the several peripheral units which are to be linked are all in close physical proximity, e.g., within twenty meters, to establish, with very high accuracy, a common time base or synchronization.” *Id.* at col. 1, ll. 50–54. “Using the common time base, code sequences are generated which control the operation of the several transmitters in a low duty cycle pulsed mode of operation.” *Id.* at col. 1, ll. 57–59. “The server and peripheral unit transmitters are energized in low duty cycle pulses at intervals which are determined by a code sequence which is timed in relation to the synchronizing information initially transmitted from the server microcomputer.” *Id.* at col. 2, ll. 35–39. “The low duty cycle pulsed operation both substantially reduces power consumption and facilitates the rejection of interfering signals.” *Id.* at col. 1, ll. 59–61. “In the intervals between slots in which a PEA is to transmit or receive, all receive and transmit circuits are powered down.” *Id.* at col. 4, ll. 6–8.

### *C. Illustrative Claim*

As noted above, Apple challenges claims 1–4 of the ’290 patent. Claim 1, the sole independent claim challenged, is reproduced below. Challenged claims 2–4 depend directly or indirectly from claim 1.

1. A data network system for effecting coordinated operation of a plurality of electronic devices, said system comprising:  
a server microcomputer unit;

a plurality of peripheral units which are battery powered and portable, which provide either input information from the user or output information to the user, and which are adapted to operate within short range of said server unit;

said server microcomputer incorporating an RF transmitter for sending commands and synchronizing information to said peripheral units;

said peripheral units each including an RF receiver for detecting said commands and synchronizing information and including also an RF transmitter for sending input information from the user to said server microcomputer;

said server microcomputer including a receiver for receiving input information transmitted from said peripheral units;

said server and peripheral transmitters being energized in low duty cycle RF bursts at intervals determined by a code sequence which is timed in relation to said synchronizing information.

Ex. 1001, col. 11, l. 61–col. 12, l. 18.

*D. Evidence of Record*

Apple relies on the following references, as well as the Declaration of Jack D. Grimes, Ph.D. (Ex. 1008):

Reference	Exhibit
Thomas J. Barber Jr., BODYLAN™: A LOW-POWER COMMUNICATION SYSTEM (M.S. thesis, Massachusetts Institute of Technology) (“Barber”)	1002
Natarajan (U.S. Patent No. 5,241,542; issued Aug. 31, 1993)	1003
Neve (U.S. Patent No. 4,887,266; issued Dec. 12, 1989)	1004

# Explore Litigation Insights

Docket Alarm provides insights to develop a more informed litigation strategy and the peace of mind of knowing you're on top of things.

## Real-Time Litigation Alerts



Keep your litigation team up-to-date with **real-time alerts** and advanced team management tools built for the enterprise, all while greatly reducing PACER spend.

Our comprehensive service means we can handle Federal, State, and Administrative courts across the country.

## Advanced Docket Research



With over 230 million records, Docket Alarm's cloud-native docket research platform finds what other services can't. Coverage includes Federal, State, plus PTAB, TTAB, ITC and NLRB decisions, all in one place.

Identify arguments that have been successful in the past with full text, pinpoint searching. Link to case law cited within any court document via Fastcase.

## Analytics At Your Fingertips



Learn what happened the last time a particular judge, opposing counsel or company faced cases similar to yours.

Advanced out-of-the-box PTAB and TTAB analytics are always at your fingertips.

## API

Docket Alarm offers a powerful API (application programming interface) to developers that want to integrate case filings into their apps.

## LAW FIRMS

Build custom dashboards for your attorneys and clients with live data direct from the court.

Automate many repetitive legal tasks like conflict checks, document management, and marketing.

## FINANCIAL INSTITUTIONS

Litigation and bankruptcy checks for companies and debtors.

## E-DISCOVERY AND LEGAL VENDORS

Sync your system to PACER to automate legal marketing.