



- [54] **TAPERED MULTILAYER LUMINAIRE DEVICES**
- [75] Inventors: **Roland Winston; Benjamin A. Jacobson, both of Chicago; Robert L. Holman, Naperville; Neil A. Gitkind, Chicago, all of Ill.**
- [73] Assignee: **NiOptics Corporation, Evanston, Ill.**
- [21] Appl. No.: **29,883**
- [22] Filed: **Mar. 11, 1993**

4,649,462	3/1987	Dobrowolski et al. ....	362/2
4,706,173	11/1987	Hamada et al. ....	362/341
4,729,068	3/1988	Ohe .....	362/31
4,735,495	4/1988	Henkes .....	362/310
4,737,896	4/1988	Mochizulki et al. ....	362/301
4,747,223	5/1988	Bonds .....	40/219
4,765,718	8/1988	Henkes .....	359/49
4,799,050	1/1989	Prine et al. ....	340/765
4,799,137	1/1989	Abo .....	362/309
4,832,458	5/1989	Ferguson .....	350/338

(List continued on next page.)

**Related U.S. Application Data**

- [63] Continuation-in-part of Ser. No. 855,838, Mar. 23, 1992, Pat. No. 5,237,641.
- [51] Int. Cl.<sup>5</sup> ..... **G02B 6/26**
- [52] U.S. Cl. .... **385/146; 385/43; 385/901; 385/129; 385/131**
- [58] Field of Search ..... **385/43, 129, 130, 131, 385/140, 146, 147, 901, 31; 359/599, 833, 834**

**References Cited**

**U.S. PATENT DOCUMENTS**

2,347,665	5/1944	Christensen et al. ....	362/31
2,712,593	7/1955	Merchant .....	362/27
3,617,109	11/1971	Tlen .....	385/43
3,752,974	8/1973	Baker et al. ....	240/1
3,832,028	8/1974	Kapron .....	385/43
3,980,392	9/1976	Aunacher .....	385/43
4,059,916	11/1977	Tachihara et al. ....	40/130
4,111,538	9/1978	Sheridon .....	353/122
4,114,592	9/1978	Winston .....	126/270
4,161,015	7/1979	Dey et al. ....	362/263
4,176,908	12/1979	Wagner .....	350/96.15
4,212,048	7/1980	Castleberry .....	362/19
4,240,692	12/1980	Winston .....	350/96.10
4,257,084	3/1981	Reynolds .....	362/31
4,277,817	7/1981	Hehr .....	362/31
4,323,951	4/1982	Pasco .....	362/27
4,373,282	2/1983	Wragg .....	40/546
4,420,796	12/1983	Mori .....	362/32
4,453,200	6/1984	Troka et al. ....	362/31
4,528,617	7/1985	Blackington .....	362/32
4,547,043	10/1985	Penz .....	362/32
4,573,766	3/1986	Bournsy, Jr. et al. ....	350/345
4,618,216	10/1986	Suzawa .....	359/49
4,648,690	3/1987	Obe .....	350/321

**OTHER PUBLICATIONS**

- "Flat Panel Backlight Reflecting Device," R. L. Garwin and R. T. Hodgson, *IBM Technical Disclosure Bulletin*, vol. 31, No. 2, Jul. 1988, pp. 190-191.
- "Dielectric Totally Internally Reflecting Concentrators" Xisohui, Ming, Roland Winston and Joseph O'Gallagher, *Applied Optics*, vol. 26, Jan. 15, 1987, pp. 300-305.

*Primary Examiner*—John D. Lee  
*Assistant Examiner*—Phan Thi Heartney  
*Attorney, Agent, or Firm*—Reinhart, Boerner, Van Deuren, Norris & Rieselbach

**[57] ABSTRACT**

An optical device for collecting light and selectively outputting or concentrating the light. A wedge layer has an optical index of refraction  $n_1$ , and top, bottom and side surfaces intersecting to define an angle of inclination  $d$ . A back surface spans the top, bottom and side surface. A first layer is coupled to the bottom surface of the layer and has an index of refraction  $n_2$ . The first layer index  $n_2$  causes light input through the back surface of the layer to be preferentially output into the first layer. A second layer is coupled to the bottom of the first layer and selectively causes output of light into ambient. Additional layers, such as an air gap, can be provided adjacent to the wedge shaped layer. The wedge shaped layer can also have a variable index of refraction  $n(x,y,z)$ .

**69 Claims, 23 Drawing Sheets**

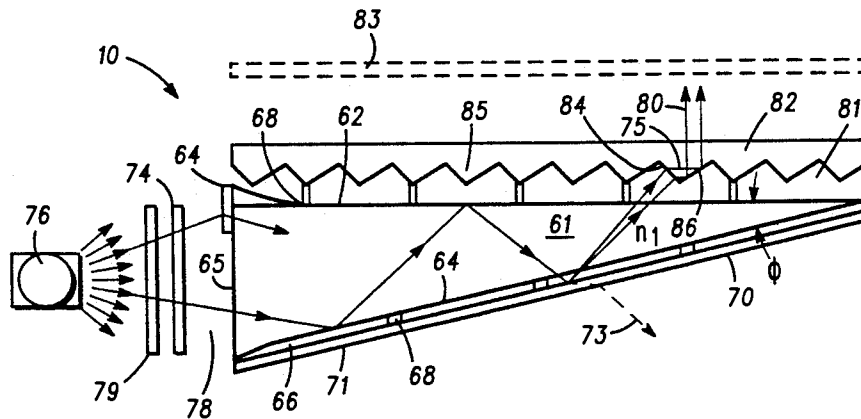

## U.S. PATENT DOCUMENTS

4,838,661	6/1989	McKee et al.	350/345
4,842,378	6/1989	Flasck et al.	350/345
4,907,044	3/1990	Schellborn et al.	357/17
4,907,132	3/1990	Parker	362/32
4,914,553	4/1990	Hamada et al.	362/321
4,915,479	4/1990	Clarke	358/345
4,936,659	6/1990	Anderson et al.	359/49
4,950,059	8/1990	Roberts	362/32
4,958,915	9/1990	Okada et al.	350/345
4,965,876	10/1990	Foldi et al.	362/247
4,974,122	11/1990	Shaw	362/31
4,974,353	12/1990	Norfolk	40/447
4,985,809	1/1991	Matsui et al.	362/31
4,989,933	2/1991	Duguay	350/96.10
4,992,916	2/1991	Henkes	362/255
4,998,188	3/1991	Degelmann	362/147
5,019,808	5/1991	Prince et al.	340/765
5,039,207	8/1991	Green	359/49
5,040,098	8/1991	Tanaka et al.	362/31
5,040,878	8/1991	Eichenlaub	350/345
5,044,734	9/1991	Sperl et al.	359/49
5,046,805	9/1991	Simon	385/31

5,046,829	9/1991	Worp	359/49
5,050,946	9/1991	Hathaway et al.	385/33
5,051,551	9/1991	Doyle	250/341
5,053,765	10/1991	Sonehara et al.	340/815.31
5,083,120	1/1992	Nelson	340/784
5,101,325	3/1992	Davenport et al.	362/31
5,128,783	7/1992	Abileah et al.	359/49
5,128,787	7/1992	Blonder	359/70
5,128,846	7/1992	Mills et al.	362/224

## OTHER PUBLICATIONS

"Optics of Two-Stage Photovoltaic Concentrators with Dielectric Second Stages", Xisohul, Ning, Roland Winston and Joseph O'Gallagher, *Applied Optics*, vol. 26, Apr. 1, 1987, pp. 1207-1212.

"New Backlighting Technologies for LCDs", Hathaway et al., *Society for Information Display Digest*, vol. 22, May 1991, pp. 751-754. "Parts that Glow", A. Bhumenfeld and S. Jones, *Machine Design*, Jul. 1985, pp. 1-11. "Directional Diffuser Lens Array for Backlit LCDs", R. I. McCartney and D. Syroid, *Japan Display*, pp. 259-262 (1992).

Fig. 1

— PRIOR ART —

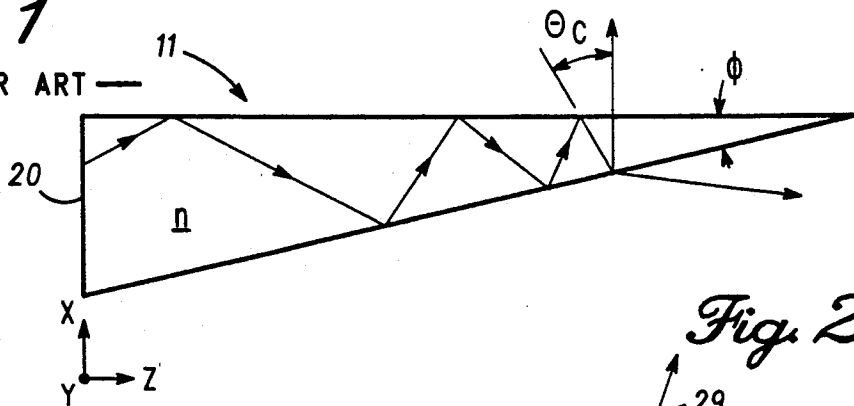

Fig. 2A

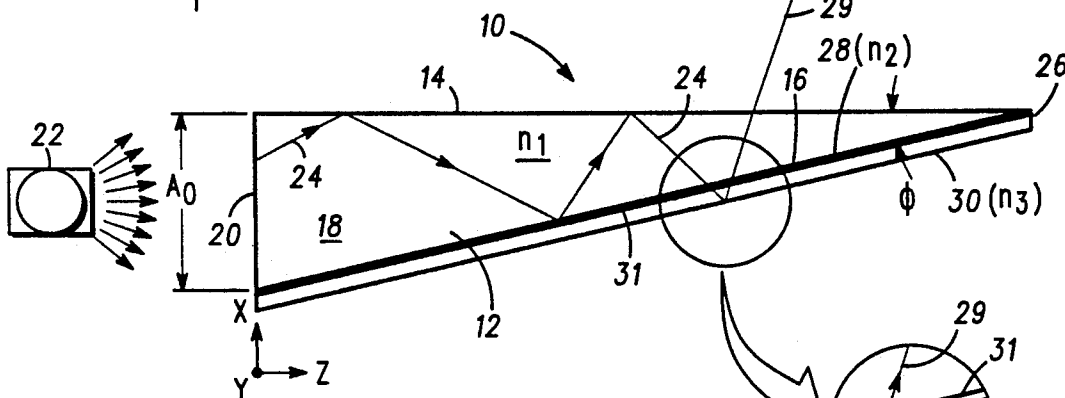

Fig. 2B

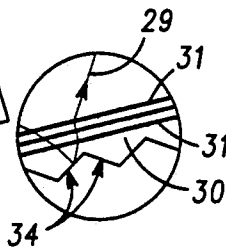

Fig. 2C

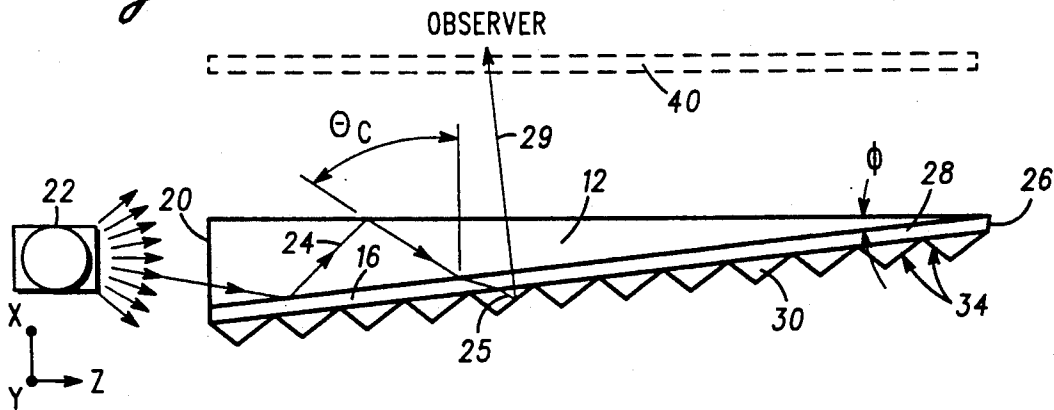
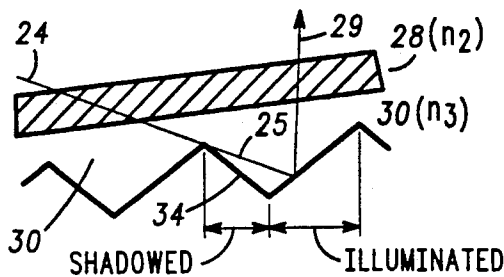
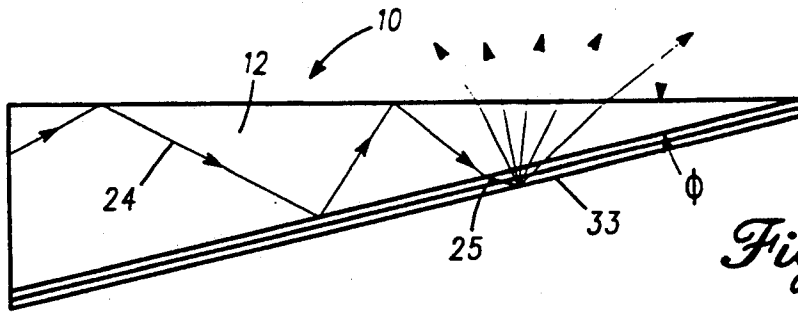
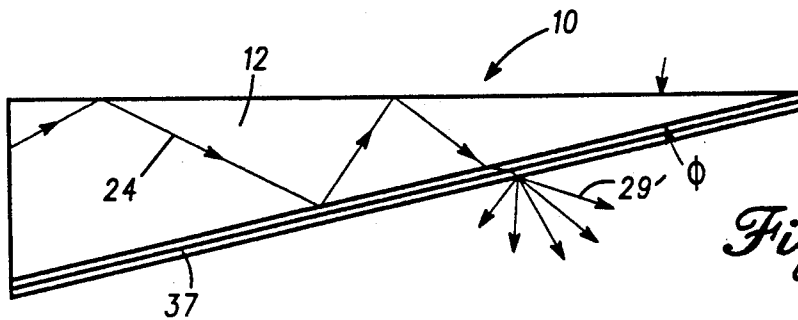

Fig. 2D

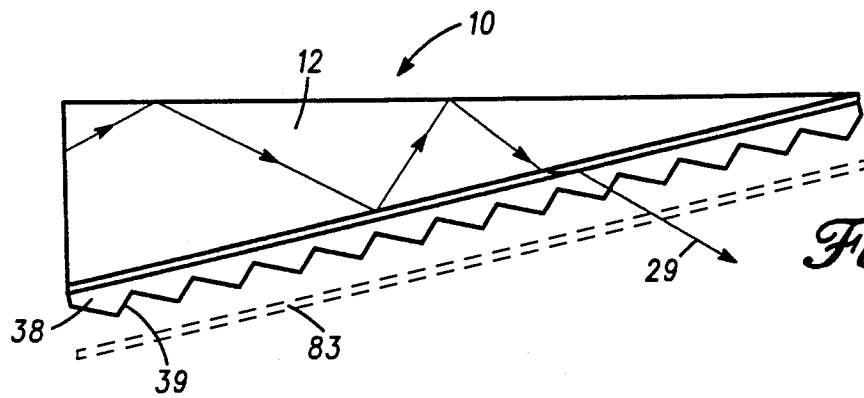



*Fig. 2E*



*Fig. 2F*



*Fig. 2G*

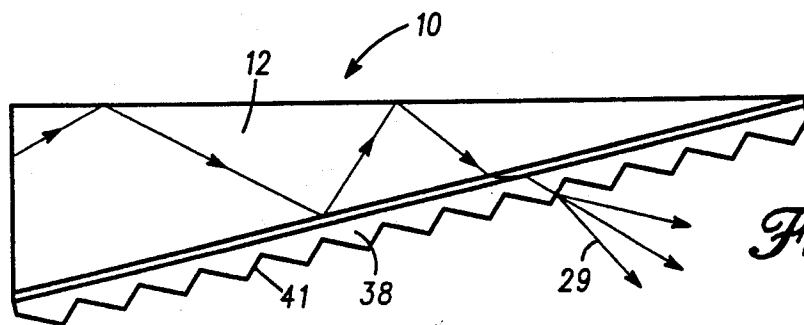

*Fig. 2H*

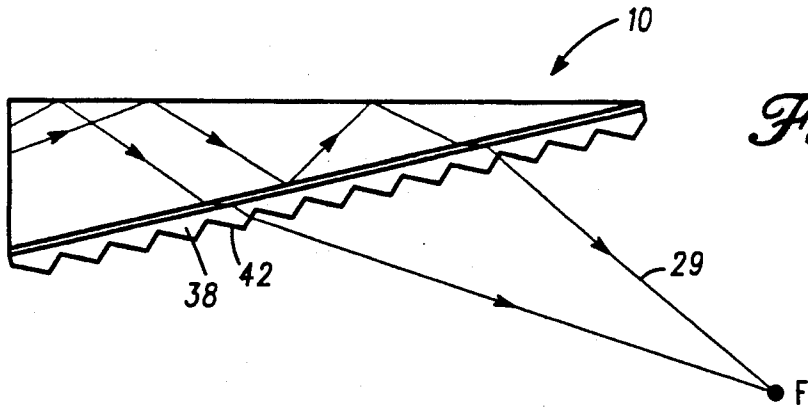

*Fig. 2I*

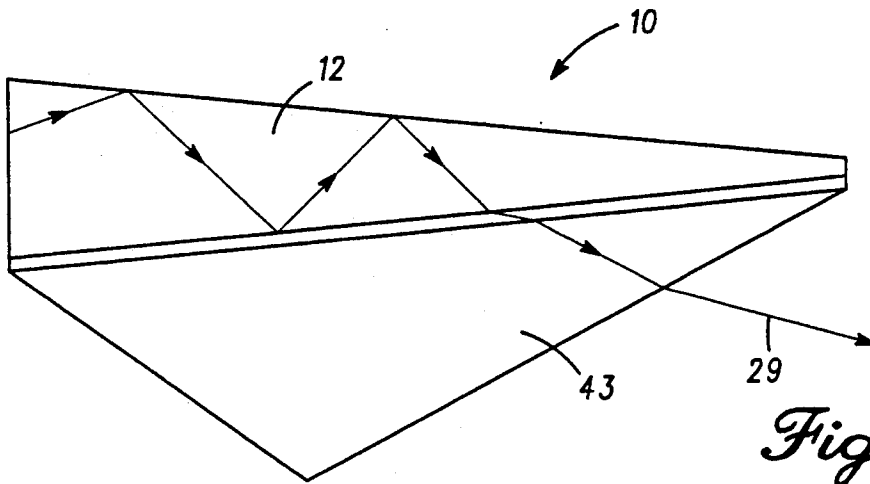

*Fig. 2J*

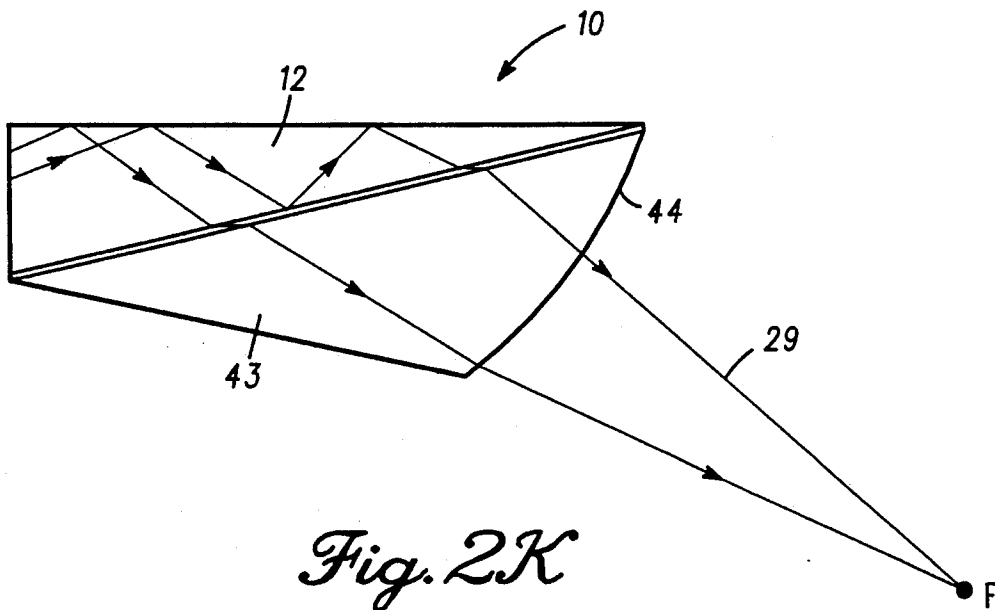

*Fig. 2K*

# Explore Litigation Insights

Docket Alarm provides insights to develop a more informed litigation strategy and the peace of mind of knowing you're on top of things.

## Real-Time Litigation Alerts



Keep your litigation team up-to-date with **real-time alerts** and advanced team management tools built for the enterprise, all while greatly reducing PACER spend.

Our comprehensive service means we can handle Federal, State, and Administrative courts across the country.

## Advanced Docket Research



With over 230 million records, Docket Alarm's cloud-native docket research platform finds what other services can't. Coverage includes Federal, State, plus PTAB, TTAB, ITC and NLRB decisions, all in one place.

Identify arguments that have been successful in the past with full text, pinpoint searching. Link to case law cited within any court document via Fastcase.

## Analytics At Your Fingertips



Learn what happened the last time a particular judge, opposing counsel or company faced cases similar to yours.

Advanced out-of-the-box PTAB and TTAB analytics are always at your fingertips.

## API

Docket Alarm offers a powerful API (application programming interface) to developers that want to integrate case filings into their apps.

## LAW FIRMS

Build custom dashboards for your attorneys and clients with live data direct from the court.

Automate many repetitive legal tasks like conflict checks, document management, and marketing.

## FINANCIAL INSTITUTIONS

Litigation and bankruptcy checks for companies and debtors.

## E-DISCOVERY AND LEGAL VENDORS

Sync your system to PACER to automate legal marketing.