



US005204897A

United States Patent [19]

[11] Patent Number: **5,204,897**

Wyman

[45] Date of Patent: **Apr. 20, 1993**

- [54] **MANAGEMENT INTERFACE FOR LICENSE MANAGEMENT SYSTEM**
- [75] Inventor: **Robert M. Wyman, Kirkland, Wash.**
- [73] Assignee: **Digital Equipment Corporation, Maynard, Mass.**
- [21] Appl. No.: **914,040**
- [22] Filed: **Jul. 14, 1992**

Related U.S. Application Data

- [63] Continuation of Ser. No. 722,840, Jun. 28, 1991, abandoned.
- [51] Int. Cl.⁵ **H04L 9/00**
- [52] U.S. Cl. **380/4; 380/25**
- [58] Field of Search **380/4, 123, 25**

References Cited

U.S. PATENT DOCUMENTS

4,780,821	10/1988	Crossley	364/200
4,791,565	12/1988	Dunham et al.	364/200
4,924,378	5/1990	Hershey et al.	364/200
4,937,863	1/1990	Robert et al.	380/4
5,023,907	6/1991	Johnson et al.	380/4
5,109,413	4/1992	Comerford et al.	380/4
5,138,712	8/1992	Corbin	380/4

OTHER PUBLICATIONS

Wyman, "Future Directions in Digital Distributed Software License Architecture", Oral presentation, DECUS (Digital Equipment Computer User Society), Marlboro, Mass., May 10, 1990, 18 pages.

Primary Examiner—Salvatore Giangialosi
 Attorney, Agent, or Firm—Arnold, White & Durkee

[57] ABSTRACT

A distributed computer system employs a license man-

agement system to account for software product usage. A management policy having a variety of alternative styles and contexts is provided. Each licensed product upon start-up makes a call to a license server to check on whether usage is permitted, and the license server checks a database of the licenses, called product use authorizations, that it administers. If the particular use requested is permitted, a grant is returned to the requesting user node. The product use authorization is structured to define a license management policy allowing a variety of license alternatives by values called "style", "context", "duration" and "usage requirements determination method". The license administration may be delegated by the license server to a subsection of the organization, by creating another license management facility duplicating the main facility. The license server must receive a license document (a product use authorization) from an issuer of licenses, where a license document generator is provided. A mechanism is provided for one user node to make a call to use a software product located on another user node; this is referred to as a "calling card", by which a user node obtains permission to make a procedure call to use a program on another node. A management interface allows a license manager at a server to modify the license documents in the database maintained by the server, within the restraints imposed by the license, to make delegations, assignments, etc. The license documents are maintained in a standard format referred to as a license document interchange format so the management system is portable and can be used by all adhering software vendors. A feature of the database management is the use of a filter function.

31 Claims, 18 Drawing Sheets

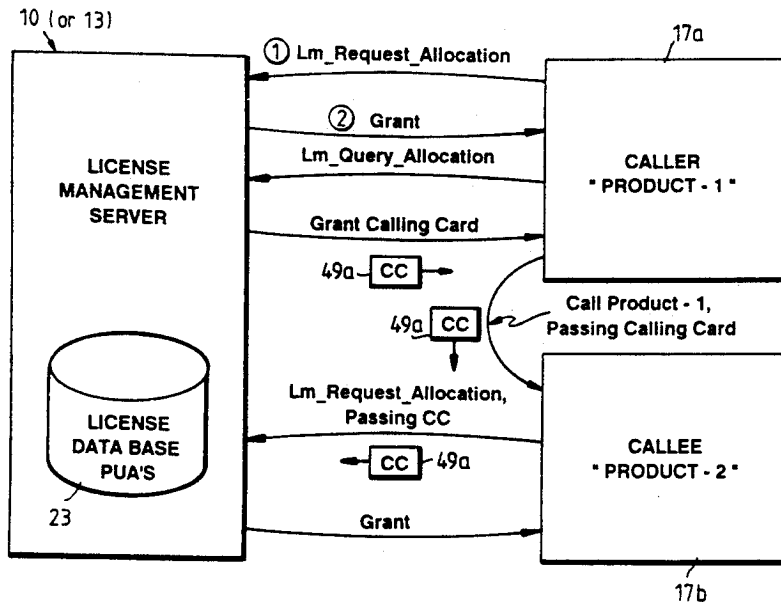
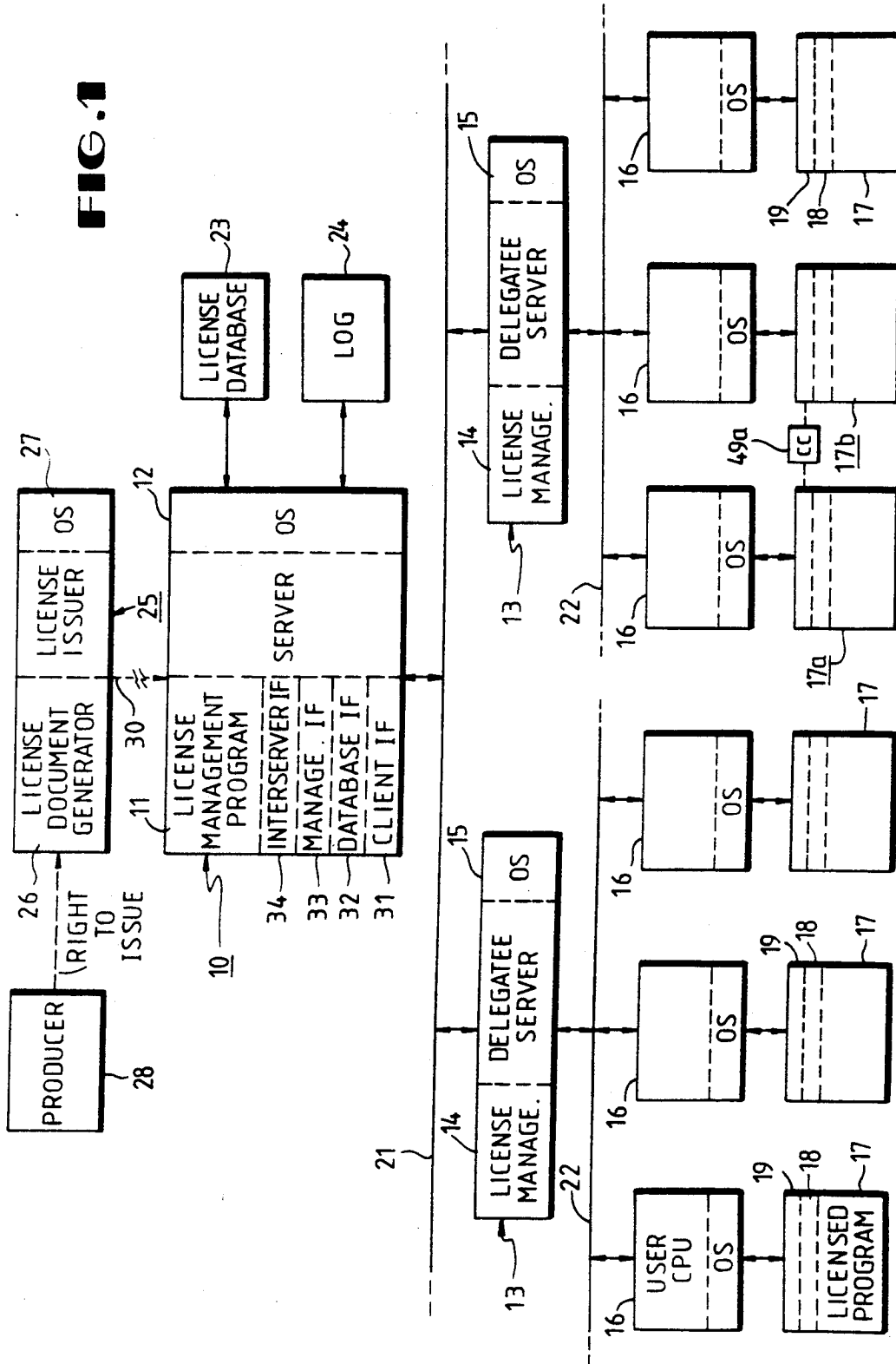
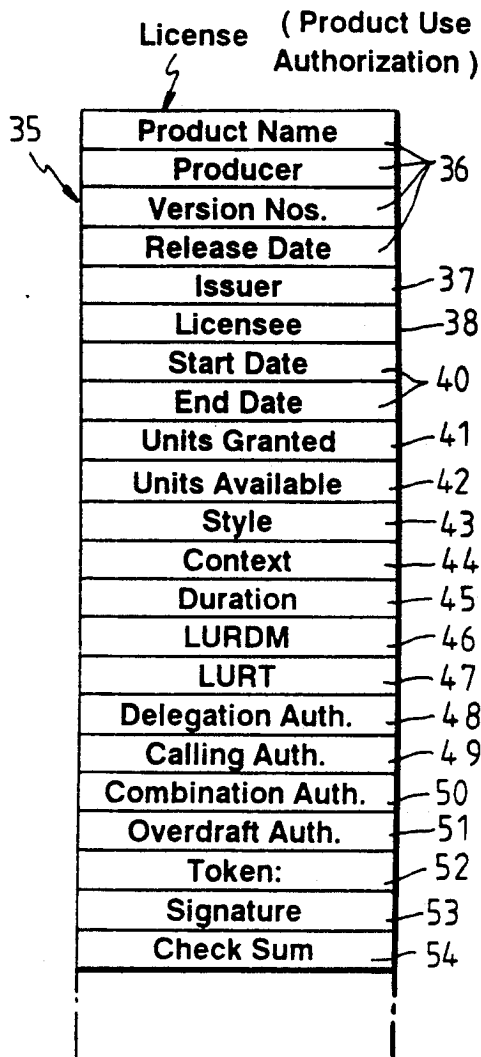

FIG. 1





License Unit Requirements Table			
Row Selector	Columns		
Platform ID	A	B	C
PC-0	10	230	-1
PC-1	12	230	-1
VAX 6210	158	300	150

FIG. 4

43	44	45	46
Style	Context	Duration	LURDM
Allocative	Network	Transaction	Constant
Consumptive	Execution_Domain	Assignment	Table Lookup
Private	Login_Domain	Immediate	Private
	Node_ID		
	Process_Family		
	Process		
	User_Name		
	Product_Name		
	Operating_System		
	Platform_ID		
	Private		

FIG. 3

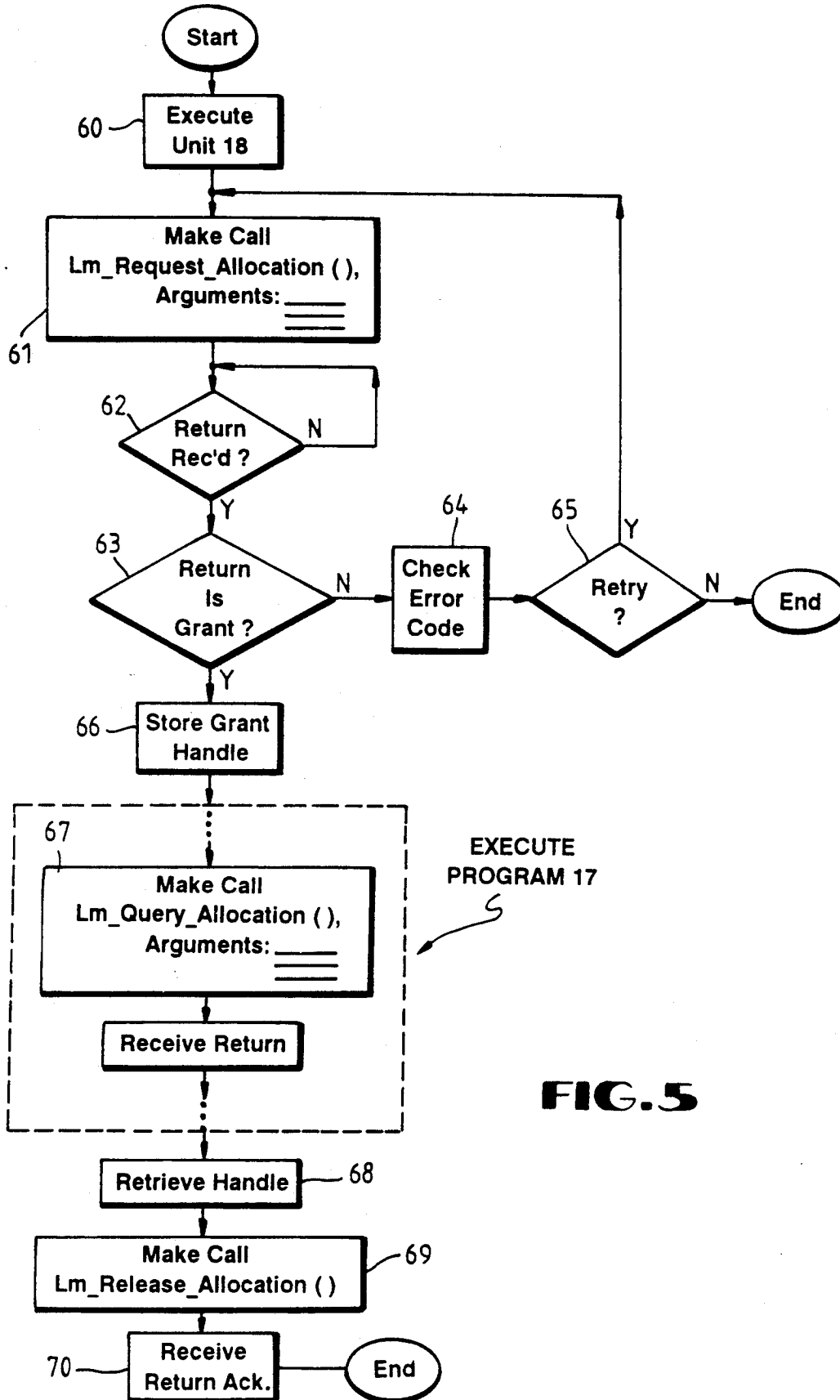

FIG. 5

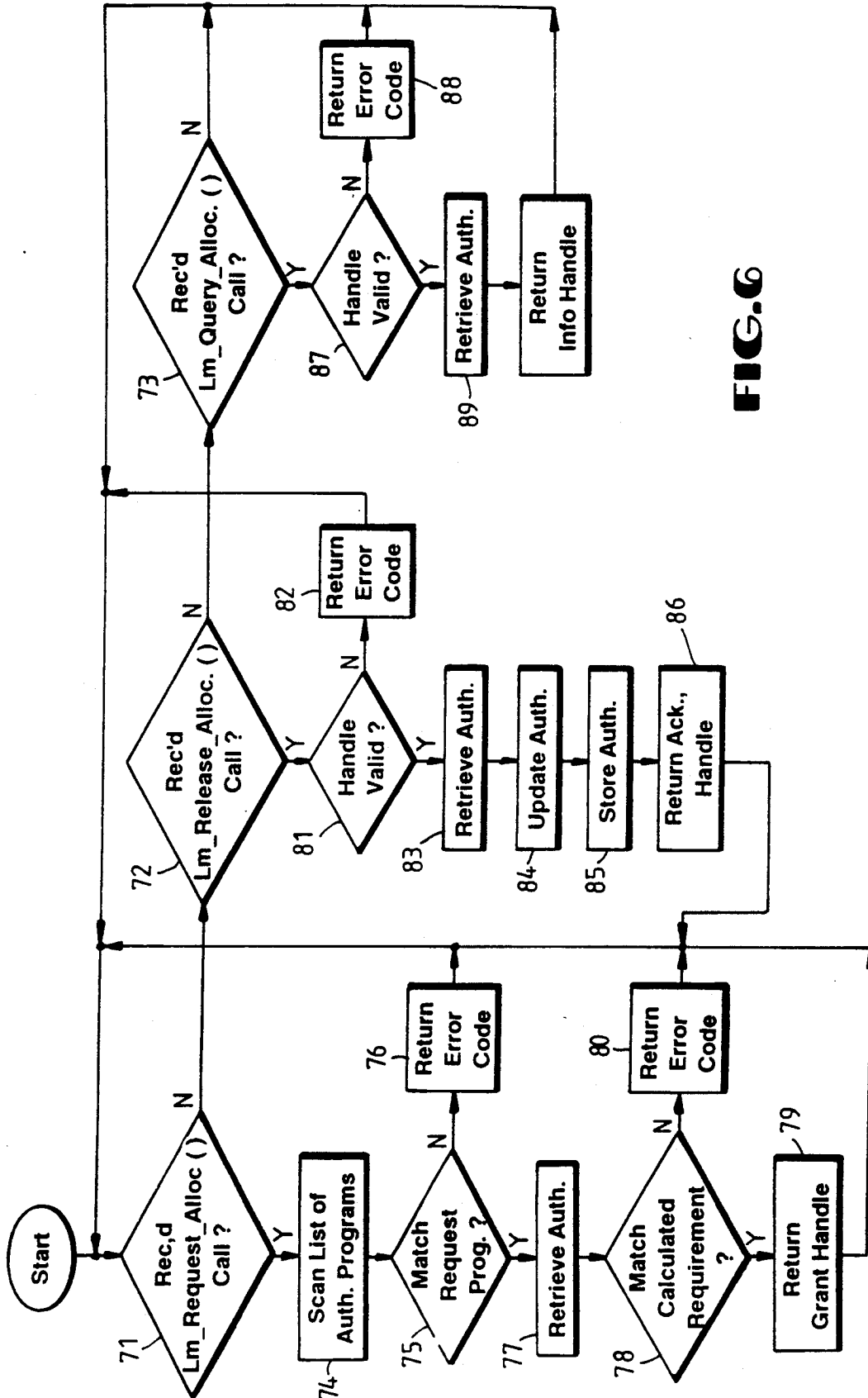

FIG. 6

Explore Litigation Insights

Docket Alarm provides insights to develop a more informed litigation strategy and the peace of mind of knowing you're on top of things.

Real-Time Litigation Alerts



Keep your litigation team up-to-date with **real-time alerts** and advanced team management tools built for the enterprise, all while greatly reducing PACER spend.

Our comprehensive service means we can handle Federal, State, and Administrative courts across the country.

Advanced Docket Research



With over 230 million records, Docket Alarm's cloud-native docket research platform finds what other services can't. Coverage includes Federal, State, plus PTAB, TTAB, ITC and NLRB decisions, all in one place.

Identify arguments that have been successful in the past with full text, pinpoint searching. Link to case law cited within any court document via Fastcase.

Analytics At Your Fingertips



Learn what happened the last time a particular judge, opposing counsel or company faced cases similar to yours.

Advanced out-of-the-box PTAB and TTAB analytics are always at your fingertips.

API

Docket Alarm offers a powerful API (application programming interface) to developers that want to integrate case filings into their apps.

LAW FIRMS

Build custom dashboards for your attorneys and clients with live data direct from the court.

Automate many repetitive legal tasks like conflict checks, document management, and marketing.

FINANCIAL INSTITUTIONS

Litigation and bankruptcy checks for companies and debtors.

E-DISCOVERY AND LEGAL VENDORS

Sync your system to PACER to automate legal marketing.