

MODERN
DICTIONARY
of
ELECTRONICS

SEVENTH EDITION
REVISED AND UPDATED

Rudolf F. Graf



NETWORK-1 EXHIBIT 2007

Newnes is an imprint of Butterworth-Heinemann.

Copyright © 1999 by Rudolf F. Graf

 A member of the Reed Elsevier Group.

All rights reserved.

No part of this publication may be reproduced, stored in a retrieval system, or transmitted in any form or by any means, electronic, mechanical, photocopying, recording, or otherwise, without the prior written permission of the publisher.

 Recognizing the importance of preserving what has been written, Butterworth-Heinemann prints its books on acid-free paper whenever possible.



Butterworth-Heinemann supports the efforts of American Forests and the Global ReLeaf program in its campaign for the betterment of trees, forests, and our environment.

Library of Congress Cataloging-in-Publication Data

Graf, Rudolf F.
Modern dictionary of electronics / Rudolf F. Graf. — 7th ed.,
revised and updated.
p. cm.
ISBN 0-7506-9866-7 (alk. paper)
1. Electronics — Dictionaries. I. Title
TK7804.G67 1999
621.381'03 — dc21

99-17889
CIP

British Library Cataloguing-in-Publication Data

A catalogue record for this book is available from the British Library.

The publisher offers special discounts on bulk orders of this book.

For information, please contact:

Manager of Special Sales
Butterworth-Heinemann
225 Wildwood Avenue
Woburn, MA 01801-2041
Tel: 781-904-2500
Fax: 781-904-2620

For information on all Butterworth-Heinemann publications available, contact our World Wide Web home page at: <http://www.bh.com>

line—1. In television, a single trace of the electron beam from left to right across the screen. The present United States standard is based on 525 lines to a complete picture. 2. A conductor of electrical energy. 3. The path of the moving spot in a cathode-ray tube. 4. A term used interchangeably for Maxwell. 5. A row of actual or potential holes at right angles to the direction in which a punched tape advances. Line width is measured in terms of the maximum number of holes permissible, excluding the sprocket hole. 6. The interconnection between two electrical devices. Usually used with reference to a long run of interconnecting cable, as from a microphone to its tape-recorder input. 7. In communications, describes cables, telephone lines, etc., over which data is transmitted to and received from the terminal.

line advance—Also called line feed. The distance between the centers of the scanning lines.

line amplifier—1. An amplifier that supplies a program transmission line or system with a signal at a specified level. 2. Also called line stretcher. An amplifier, usually remotely powered, used in a trunk line in a distribution system to increase the strength of the signal in order to drive an additional length of cable. 3. Also called program amplifier. An amplifier for audio or video signals that feeds a transmission line. 4. An audio amplifier that is used to provide preamplification of an audio alarm signal before transmission of the signal over an alarm line. Use of an amplifier extends the range of signal transmission. 5. An amplifier that supplies an audio system or an audio long cable with a signal at a specified level, usually between -10 and $+4$ dBv (245 millivolts to 1.23 volts rms). 6. An amplifier inserted in any part of the transmission line following the downconverter to compensate signal losses caused by long lengths of coaxial cable or the insertion of passive devices such as splitters. Line amplifiers are also used when the signal must drive a number of television receivers.

line and trunk group—A group consisting of four-wire line circuits, incoming trunks from private automatic branch exchanges, and intertoll trunk groups.

linear—1. Having an output that varies in direct proportion to the input. 2. A ratio in which change in one of two related quantities is accompanied by a directly proportional change in the other.

linear acceleration—The rate of change in linear velocity.

linear accelerator—A device for speeding up charged particles such as protons. It differs from other accelerators in that the particles move in a straight line instead of in circles or spirals.

linear accelerometer—A transducer used to detect, measure, and record the rate of change in linear velocity of accelerative forces.

linear actuator—An actuator that produces mechanical motion from electrical energy.

linear amplification—Amplification in which the output is directly proportional to the input.

linear amplifier—1. An amplifier that operates on the linear portion of its forward transfer characteristic so that its output signal is always an amplified replica of the input signal. 2. Amplifier whose gain is constant for a wide variation in amplitude of input signal—i.e., output signal is proportional to input signal. 3. Amplifier that has linear control characteristics and negligible response time in the active bandwidth, provides a wide speed range, and usually requires minimal external circuitry to prevent instability caused by phase-shifted feedback

multielement antenna in which individual dipole elements are arranged end to end.

linear circuit—1. A circuit in which the output voltage is approximately directly proportional to the input voltage; this relationship generally exists only over a limited range of signal voltages and often over a limited range of frequencies. 2. A circuit whose output is a continuous amplified version of its input. That is, the output is a predetermined variation of its input. 3. A circuit in which a proportional, or linear, relationship exists between the input and output. In manufacturers' circuit classifications the term often includes all analog circuits, both linear and nonlinear.

linear control—A rheostat or potentiometer having uniform distribution of graduated resistance along the entire length of its resistance element.

linear detection—Detection in which the output voltage is substantially proportionate to the input voltage over the useful range of the detector.

linear detector—A detector that produces an output signal directly proportionate in amplitude to the variations in amplitude (for AM transmission) or frequency (for FM transmission) of the rf input.

linear device—An amplifying-type analog device with a linear input/output relation, as opposed to a nonlinear digital device, which is either completely on or completely off over large ranges of input signals.

linear differential transformer—A type of electromechanical transducer that converts physical motion into an output voltage, the phase and amplitude of which are proportional to position. *See also* linear motion transducer.

linear distortion—Amplitude distortion in which the output and input signal envelopes are not proportionate, but no alien frequencies are involved.

linear electrical parameters of a uniform line—Frequently called the linear electrical constants. The series resistance and inductance, and the shunt conductance and capacitance, per length of a line.

linear electron accelerator—An evacuated metal tube in which electrons are accelerated through a series of small gaps (usually cavity resonators in the high-frequency range). The gaps are so spaced that, at a specific excitation frequency, the electrons gain additional energy from the electric field as they pass through successive gaps.

linear feedback-control system—A feedback-control system in which the relationship between the pertinent measure of the system signals is linear.

linear integrated circuit—Abbreviated LIC. 1. A circuit whose output is an amplified, linear version of its input or whose output is a predetermined variation of its input. A class of integrated circuits that process analog information expressed as voltages or currents. 2. An integrated circuit whose output remains proportional to the input level. Generally the term is taken to mean an analog IC, such as a voltage regulator, comparator, sense amplifier, driver, etc., as well as a linear amplifier. The operation of the circuit can be made nonlinear by connecting the basic linear amplifier to external circuit elements that have thresholds or other nonlinear characteristics.

linearity—1. The relationship existing between two quantities when a change in a second quantity is directly proportionate to a change in the first quantity. 2. Deviation from a straight-line response to an input signal. 3. The ability of a meter to provide equal angular

theoretical straight line. Linearity is often confused with tracking. 5. In a modulator, the ability to generate a modulation envelope that reproduces the modulating signal without distortion. 6. The state of an output that incrementally changes directly or proportionally as the input changes. 7. The closeness of a calibration curve to a specified straight line; the degree to which the output of a linear device is proportional to the input.

linearity control—A control that adjusts the variation of scanning speed through the trace interval.

linearity error—The deviation of a calibration curve from a specified straight line.

linear logarithmic intermediate-frequency amplifier—An amplifier used to avoid overload or saturation as a protection against jamming in a radar receiver.

linear magnetostriction—Under stated conditions, the relative change of length of a ferromagnetic object in the direction of magnetization when the magnetization of the object is increased from zero to a specified value (usually saturation).

linear mobility—The synchronized incremental mobility of functionally transitional electrons in a semiconductor.

linear modulation—Modulation in which the amplitude of the modulation envelope (or the deviation from the testing frequency) is directly proportional to the amplitude of the modulating wave at all audio frequencies.

linear modulator—A modulator in which the modulated characteristic of the output wave is substantially linear with respect to the modulating wave for a given magnitude.

linear motion transducer—An instrumentation component that translates straightline (linear) mechanical motion into an ac analog that is usable as a feedback signal for control or display. A transformer-type device in which a movable magnetic core is displaced axially by the moving component being monitored. When the core is moved in one direction from the center of its stroke, the output voltage is in phase with the excitation voltage, and when the core is moved in the opposite direction from the center, the output voltage is 180° out of phase. At the center, the output voltage is (virtually) zero. In either direction from center, the voltage increases as a precise linear function of probe displacement. Thus, the output signal has two basic analog components: phase relationship with the excitation voltage, indicating the direction of travel; and voltage amplitude, indicating the length of travel.

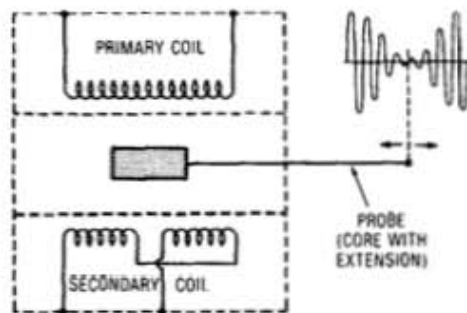

Linear motion transducer.

linear polarized wave—At a point in a homogeneous isotropic medium, a transverse electromagnetic wave whose electric field vector lies along a fixed line.

linear power amplifier—A power amplifier in which the output voltage is directly proportionate to the input voltage.

linear predictive coding—1. A method of analyzing and storing human speech by determining from speech patterns a description of a time-varying digital filter modeling the vocal tract. This filter is then excited by the proper type of input, depending on the sound to be synthesized. The output of the filter is passed through a digital-to-analog converter whose output is the desired synthetic speech. 2. Speech synthesis technique based in the frequency domain. The quality of the synthesis improves as the number of coefficients is increased. With ten coefficients, an approximate number of bits per second required for speech is 1200. 3. A parameter-encoding technique that models the human vocal tract with a digital filter whose controlling parameters change with time. Changes are based on previous speech samples.

linear programming—In computers, a mathematical method of sharing a group of limited resources among a number of competing demands. All decisions are interlocking because they must be made under a common set of fixed limitations.

linear pulse amplifier—A pulse amplifier that maintains the peak amplitudes of the input and output pulses in proportion.

linear rectification—The production, in the rectified current or voltage, of variations that are proportionate to variations in the input wave amplitude.

linear rectifier—A rectifier with the same output current or voltage waveshape as that of the impressed signal.

linear regression—A statistical function used when handling experimental data. It is especially used when performing an experiment to find a mathematical relationship between two variables. Linear regression is the name of the procedure that is used to find the line that best fits the set of data points that have been found experimentally. The procedure usually finds the equation of the straight line and also a parameter called the correlation coefficient, which indicates how well the data fits the line.

linear scan—A radar beam that traverses only one arc or circle.

linear scanning—Scanning in which a radar beam generates only one arc or circle.

linear sweep—In a television receiver, the movement of the spot across the screen at a uniform velocity during active scanning intervals.

Linearsyn—A linear displacement pickoff of the differential-transformer type consisting of a coil assembly and a movable magnetic core. Linear velocity units of high-coercive-force permanent magnetic cores that induce sizeable dc voltages while moving concentrically within shielded coils; the voltage varies linearly with the core velocity (Sanborn Co.).

line art—A computer-drawn graphic (without halftones) that can be clearly printed.

linear taper—A potentiometer that changes the resistance linearly as it is rotated through its range.

linear time base—In a cathode-ray tube, the time base in which the spot moves at a constant speed along the time scale. This type of time base is produced by application of a sawtooth waveform to the horizontal-