



US005954781A

# United States Patent [19]

[11] Patent Number: **5,954,781**

Slepian et al.

[45] Date of Patent: **Sep. 21, 1999**

- [54] **METHOD AND APPARATUS FOR OPTIMIZING VEHICLE OPERATION**
- [75] Inventors: **Harvey Slepian**, Peoria; **Loran Sutton**, East Peoria, both of Ill.
- [73] Assignee: **TAS Distributing Co., Inc.**, Peoria, Ill.
- [21] Appl. No.: **08/813,270**
- [22] Filed: **Mar. 10, 1997**
- [51] Int. Cl.<sup>6</sup> ..... **G06F 7/00**
- [52] U.S. Cl. .... **701/96; 701/103; 340/425.5; 340/438**
- [58] Field of Search ..... 701/1, 121, 123, 701/101, 102, 103, 104, 96, 300; 123/478, 480, 351, 481; 340/903, 425.5, 426, 436, 438

*Primary Examiner*—William A. Cuchlinski, Jr.  
*Assistant Examiner*—Gertrude Arthur  
*Attorney, Agent, or Firm*—Haynes and Boone, LLP

### [57] ABSTRACT

Apparatus for optimizing operation of an engine-driven vehicle. The apparatus includes a processor subsystem, a memory subsystem, a road speed sensor, an engine speed sensor, a manifold pressure sensor, a throttle position sensor, a radar detector for determining the distance separating the vehicle from an object in front of it, a windshield wiper sensor for indicating whether a windshield wiper of the vehicle is activated, a brake sensor for determining whether the brakes of the vehicle have been activated, a fuel over-injection notification circuit for issuing notifications that excessive fuel is being supplied to the engine of the vehicle, an upshift notification circuit for issuing notifications that the engine of the vehicle is being operated at an excessive engine speed, a downshift notification circuit for issuing notifications that the engine of the vehicle is being operated at an insufficient engine speed, a vehicle proximity alarm circuit for issuing an alarm that the vehicle is too close to an object in front of the vehicle and a throttle controller for automatically reducing the amount of fuel supplied to the engine if the vehicle is too close to the object in front of it. Based upon data received from the sensors and data stored in the memory subsystem, the processor determines whether to activate the fuel overinjection notification circuit, the upshift notification circuit, the downshift notification circuit, the vehicle proximity alarm circuit or the throttle controller.

### [56] References Cited

#### U.S. PATENT DOCUMENTS

4,492,112	1/1985	Igarashi et al. ....	73/117.3
4,542,460	9/1985	Weber .....	364/424
4,631,515	12/1986	Blee et al. ....	340/62
4,701,852	10/1987	Ulveland .....	364/424.1
4,752,883	6/1988	Asakura et al. ....	364/424.1
4,853,673	8/1989	Kido et al. ....	340/439
4,868,756	9/1989	Kawanabe et al. ....	364/442
4,901,701	2/1990	Chasteen .....	123/478
5,420,792	5/1995	Butsuen et al. ....	701/96
5,708,584	1/1998	Doi et al. ....	701/96
5,745,870	4/1998	Yamamoto et al. ....	701/96

**32 Claims, 3 Drawing Sheets**

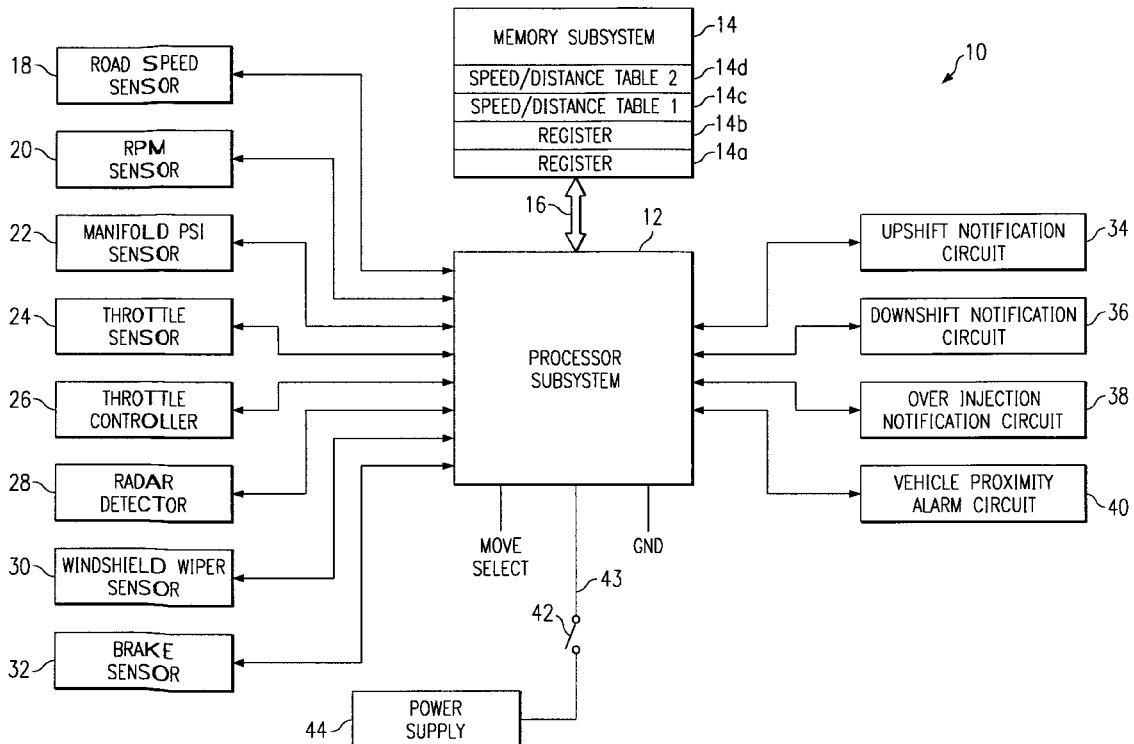

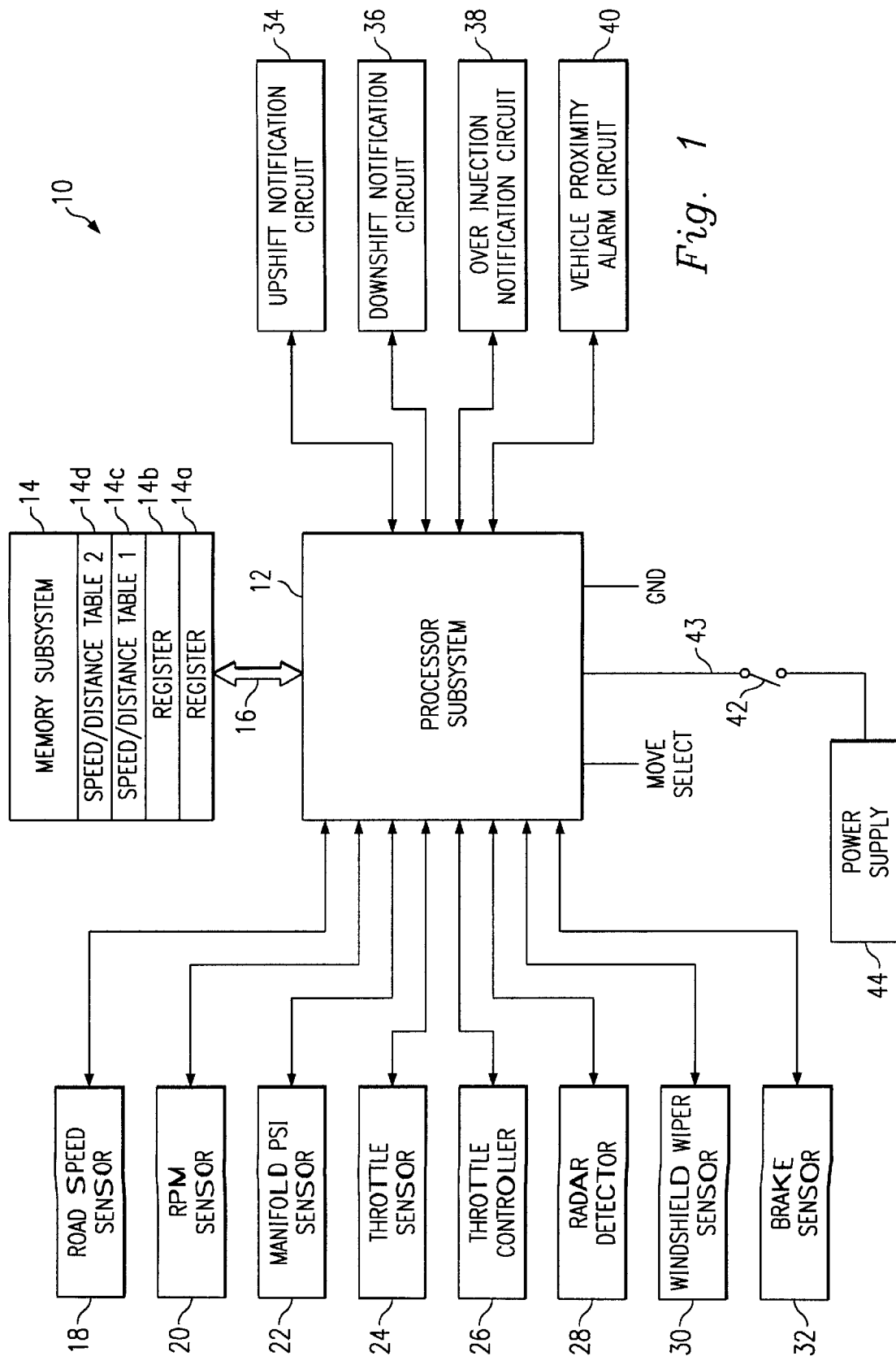
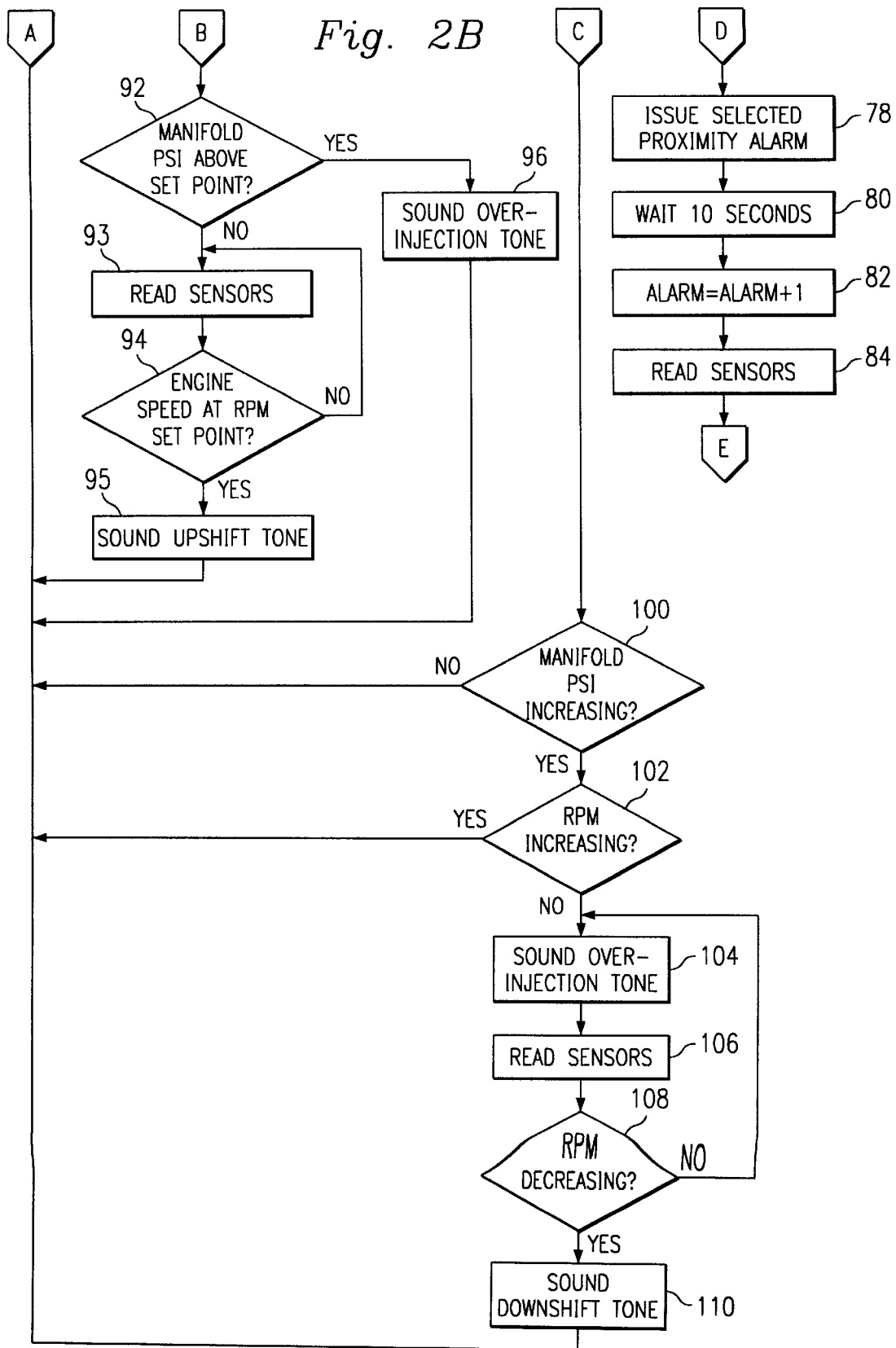

Fig. 1





## METHOD AND APPARATUS FOR OPTIMIZING VEHICLE OPERATION

### BACKGROUND OF THE INVENTION

#### 1. Field of the Invention

The present invention generally relates to an apparatus for optimizing vehicle operation and, more particularly, relates to a system which both notifies the driver of recommended corrections in vehicle operation and, under certain conditions, automatically initiates selected corrective action.

#### 2. Description of Related Art

It has long been recognized that the improper operation of a vehicle may have many adverse effects. For example, the fuel efficiency of a vehicle may vary dramatically based upon how the vehicle is operated. More specifically, operating a vehicle at excessive speed, excessive RPM and/or excessive manifold pressure will result in both reduced fuel economy and increased operating costs. The aforementioned increased operating costs can be quite considerable, particularly for an owner or operator of a fleet of vehicles. To correct these types of improper vehicle operations are often surprisingly simple. For example, upshifting the drive gear will typically eliminate an excessive RPM condition. However, even when the solution is quite simple, oftentimes, the driver will be unaware of the need to take corrective action.

A variety of patents have disclosed systems, commonly referred to as "shift prompters", which monitor the operation of a vehicle and advises the operator of the vehicle when to take certain actions. Numerous ones of these devices include sensors which measure engine speed and vehicle speed. See, for example, U.S. Pat. No. 4,492,112 to Igarashi et al., U.S. Pat. No. 4,631,515 to Blee et al. and U.S. Pat. No. 4,701,852 to Ulveland. Certain ones, however, disclose the use of other types of sensors as well. For example, U.S. Pat. No. 4,524,460 to Weber is directed to a driving aid indicator which includes vehicle speed, manifold pressure, throttle position and engine speed sensors. U.S. Pat. No. 4,752,883 to Asakura et al. and U.S. Pat. No. 4,868,756 to Kawanabe et al. are directed to upshift notification devices which include sensors for measuring engine speed, vehicle speed, manifold pressure and cooling water temperature. Finally, U.S. Pat. No. 4,853,673 to Kido et al. discloses a shift indicator system which includes sensors for measuring engine speed and throttle position. Generally, the above-listed patents all provide displays intended to enable the driver to operate the vehicle in a manner leading to uniform performance and maximum fuel economy. However, Blee et al. discloses the use of audible warnings as well as a speed controller to prevent further increases in engine speed if the driver ignores previously issued warnings.

Improper vehicle operation has other adverse effects as well. It is well known that the faster a vehicle travels, the longer it takes to stop. Thus, what may be a safe separation distance between successive vehicles when a vehicle is traveling at 35 mph may be unsafe if that vehicle is traveling at 50 mph. Road conditions also play a role in determining the safe separation distance between vehicles. For example, greater separation distances are generally recommended when roads are wet. As a result, therefore, based on the combination of a vehicle's speed, the distance separating the vehicle from a second vehicle in front of it and road conditions, many vehicles are operated unsafely. To correct this situation, a reduction in operating speed, an increase in vehicle separation or some combination thereof, is required.

It may be readily seen from the foregoing that it would be desirable to provide a system which integrates the ability to

issue audible warnings which advise the driver to correct operation of the vehicle in a manner which will enhance the efficient operation thereof with the ability to automatically take corrective action if the vehicle is being operated unsafely. It is, therefore, the object of the invention to provide such a system.

### SUMMARY OF THE INVENTION

In one embodiment, the present invention is directed to an apparatus for optimizing operation of an engine-driven vehicle. The apparatus includes a processor subsystem, a memory subsystem, plural sensors, including road speed, manifold pressure and throttle position sensors, for collectively monitoring operation of the vehicle and a fuel overinjection notification circuit for issuing notifications that excessive fuel is being supplied to the engine of the vehicle. The processor subsystem receives data from the sensors and, from the received data, determines when to activate the fuel overinjection circuit. In one aspect thereof, the processor subsystem determines when road speed for the vehicle is increasing, determines when throttle position for the vehicle is increasing, compares manifold pressure and a manifold pressure set point stored in the memory subsystem and activates the fuel overinjection notification circuit if both road speed and throttle position for the vehicle are increasing and manifold pressure for the vehicle is above the manifold pressure set point.

In further aspects thereof, the sensors may include an engine speed sensor and the processor subsystem may determine when road speed for the vehicle is decreasing, when throttle position for the vehicle is increasing, when manifold pressure for the vehicle is increasing, when engine speed for the vehicle is decreasing and may activate the fuel overinjection notification circuit if both throttle position and manifold pressure for the vehicle are increasing and road speed and engine speed for the vehicle are decreasing.

In still further aspects thereof, the apparatus may also include an upshift notification circuit, activated by the processor subsystem based upon data received from the sensors, which issues notifications that the engine of the vehicle is being operated at excessive engine speeds. In this aspect, the processor subsystem determines when road speed for the vehicle is increasing, when throttle position for the vehicle is increasing, compares manifold pressure to a manifold pressure set point stored in the memory subsystem, compares engine speed to an RPM set point stored in the memory subsystem and activates the upshift notification circuit if both road speed and throttle position for the vehicle are increasing, manifold pressure for the vehicle is at or below the manifold pressure set point and engine speed for the vehicle is at or above the RPM set point.

In still yet further aspects thereof, the apparatus may also include a downshift notification circuit, activated by the processor subsystem based upon data received from the sensors, which issues a notification that the engine of the vehicle is being operated at an insufficient engine speed. The processor subsystem may determine when road speed for the vehicle is decreasing, when throttle position for the vehicle is increasing, when manifold pressure for the vehicle is increasing, when engine speed for the vehicle is decreasing and may activate the downshift notification circuit if both road speed and engine speed are decreasing and both throttle position and manifold pressure for the vehicle are increasing.

In still further aspects thereof, the fuel overinjection circuit, the upshift notification circuit or the downshift

# Explore Litigation Insights

Docket Alarm provides insights to develop a more informed litigation strategy and the peace of mind of knowing you're on top of things.

## Real-Time Litigation Alerts



Keep your litigation team up-to-date with **real-time alerts** and advanced team management tools built for the enterprise, all while greatly reducing PACER spend.

Our comprehensive service means we can handle Federal, State, and Administrative courts across the country.

## Advanced Docket Research



With over 230 million records, Docket Alarm's cloud-native docket research platform finds what other services can't. Coverage includes Federal, State, plus PTAB, TTAB, ITC and NLRB decisions, all in one place.

Identify arguments that have been successful in the past with full text, pinpoint searching. Link to case law cited within any court document via Fastcase.

## Analytics At Your Fingertips



Learn what happened the last time a particular judge, opposing counsel or company faced cases similar to yours.

Advanced out-of-the-box PTAB and TTAB analytics are always at your fingertips.

## API

Docket Alarm offers a powerful API (application programming interface) to developers that want to integrate case filings into their apps.

## LAW FIRMS

Build custom dashboards for your attorneys and clients with live data direct from the court.

Automate many repetitive legal tasks like conflict checks, document management, and marketing.

## FINANCIAL INSTITUTIONS

Litigation and bankruptcy checks for companies and debtors.

## E-DISCOVERY AND LEGAL VENDORS

Sync your system to PACER to automate legal marketing.