

INTERNATIONAL APPLICATION PUBLISHED UNDER THE PATENT COOPERATION TREATY (PCT)

<p>(51) International Patent Classification ⁶ : A61F 13/02, A61L 15/16</p>	<p>A1</p>	<p>(11) International Publication Number: WO 95/24172 (43) International Publication Date: 14 September 1995 (14.09.95)</p>
<p>(21) International Application Number: PCT/US95/00609 (22) International Filing Date: 17 January 1995 (17.01.95) (30) Priority Data: 08/207,786 7 March 1994 (07.03.94) US (71) Applicant: THERATECH, INC. [US/US]; Suite 100, 417 Wakara Way, Salt Lake City, UT 84108 (US). (72) Inventors: EBERT, Charles, D.; 1515 South Canterbury Drive, Salt Lake City, UT 84108 (US). VENKATESHWARAN, Srinivasan; 2411 Emerson Avenue, Salt Lake City, UT 84108 (US). HEIBER, Werner; 1569 South 2300 East, Salt Lake City, UT 84108 (US). BORSADIA, Suresh; 4887 South 1710 East, Salt Lake City, UT 84117 (US). (74) Agent: HOWARTH, Alan, J.; Thorpe, North & Western, Suite 200, 9035 South 700 East, Sandy, UT 84070 (US).</p>		<p>(81) Designated States: AU, CA, CN, JP, KR, MX, European patent (AT, BE, CH, DE, DK, ES, FR, GB, GR, IE, IT, LU, MC, NL, PT, SE). Published <i>With international search report.</i></p>

(54) Title: DRUG-CONTAINING ADHESIVE COMPOSITE TRANSDERMAL DELIVERY DEVICE

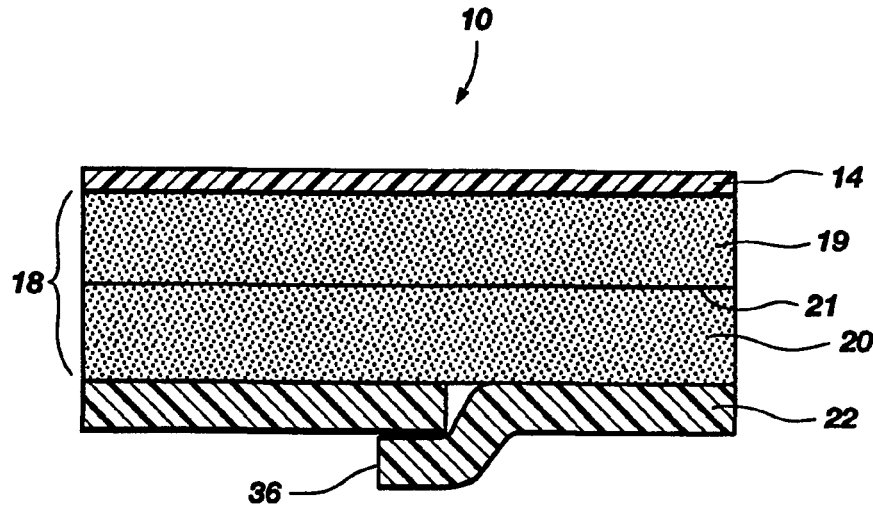

(57) Abstract

A method for making a transdermal drug delivery device for heat sensitive and volatile drugs is disclosed. The device contains a drug-containing adhesive composite layer having an impermeable backing material laminated to the distal surface thereof and a proximal peelable impermeable backing material adapted for removal for administering a drug to the skin or mucosa laminated to the proximal surface thereof. The figure provides a partly schematic, sectional view of the transdermal drug delivery device (10) including the substantially drug-impermeable distal backing (14), a drug laden adhesive composite (18) and a substantially drug impermeable proximal release liner (22). The adhesive composite (18) is comprised of a distal adhesive layer (19), a proximal adhesive layer (20) and a gelled drug layer (21) disposed therebetween. The device is produced by extruding the drug in gel form onto at least one exposed surface of a first or second adhesive laminate such that the adhesive layers and gelled drug are combined to form the drug-containing adhesive composite layer having the distal and proximal surfaces covered by the respective backing materials. This process is particularly adaptable to the formulation of nicotine-containing patches.

FOR THE PURPOSES OF INFORMATION ONLY

Codes used to identify States party to the PCT on the front pages of pamphlets publishing international applications under the PCT.

AT	Austria	GB	United Kingdom	MR	Mauritania
AU	Australia	GE	Georgia	MW	Malawi
BB	Barbados	GN	Guinea	NE	Niger
BE	Belgium	GR	Greece	NL	Netherlands
BF	Burkina Faso	HU	Hungary	NO	Norway
BG	Bulgaria	IE	Ireland	NZ	New Zealand
BJ	Benin	IT	Italy	PL	Poland
BR	Brazil	JP	Japan	PT	Portugal
BY	Belarus	KE	Kenya	RO	Romania
CA	Canada	KG	Kyrgystan	RU	Russian Federation
CF	Central African Republic	KP	Democratic People's Republic of Korea	SD	Sudan
CG	Congo	KR	Republic of Korea	SE	Sweden
CH	Switzerland	KZ	Kazakhstan	SI	Slovenia
CI	Côte d'Ivoire	LI	Liechtenstein	SK	Slovakia
CM	Cameroon	LK	Sri Lanka	SN	Senegal
CN	China	LU	Luxembourg	TD	Chad
CS	Czechoslovakia	LV	Latvia	TG	Togo
CZ	Czech Republic	MC	Monaco	TJ	Tajikistan
DE	Germany	MD	Republic of Moldova	TT	Trinidad and Tobago
DK	Denmark	MG	Madagascar	UA	Ukraine
ES	Spain	ML	Mali	US	United States of America
FI	Finland	MN	Mongolia	UZ	Uzbekistan
FR	France			VN	Viet Nam
GA	Gabon				

**DRUG-CONTAINING ADHESIVE COMPOSITE TRANSDERMAL
DELIVERY DEVICE**

10

Background of the Invention

This invention relates generally to transdermal and transmucosal drug delivery (TDD) devices. More particularly, the invention relates to TDD devices for delivering heat sensitive or volatile drugs in which the drug is extruded as a gel onto an adhesive layer following which the surface of the adhesive layer onto which the gel has been extruded is laminated with a second adhesive layer to form a drug-containing adhesive composite device. Chemical enhancers for facilitating transport of the drug through the skin or mucosa and other additives can also be mixed with the drug or into the composite. Thus, the invention encompasses a method for making TDD devices using an extrusion step to incorporate a gelled drug into a dried adhesive layer, and to drug delivery devices made using the method. These methods and devices are particularly useful for delivering nicotine into the body.

30

Cigarette smoking is a major risk factor in coronary heart disease and is the cause of approximately 30% of all cancer deaths. However, smoking is difficult to give up, and any smoking cessation therapy has to deal with both the pharmacological and psychological dependence on cigarettes. Modest success has been obtained by separating the treatment of these two factors, such as by satisfying the pharmacological craving with nicotine pills or chewing gum while treating the psychological addiction independently.

40

One of the most successful approaches relies on nicotine chewing gum, which achieves direct delivery of nicotine to the systemic circulation by buccal absorption. However, nicotine chewing gum tastes bad, may lead to mouth ulcers and heartburn, and destroys

45

dental appliances. Further, patient compliance is crucial to effectiveness. Other problems with orally administered nicotine include stomach upsets, nausea, rapid nicotine degradation, and irregular and unpredictable blood levels.

Another approach gaining increasing favor for treating the pharmacological dependence on cigarette smoking is transdermal delivery of nicotine. The skin is ordinarily a very effective barrier to passage of materials from the environment into the body. However, nicotine is very volatile, highly lipid soluble, and permeates the skin easily. For example, a comparison of average penetration rates of other transdermally administered agents through the skin show that nitroglycerin has a skin flux of 10-25 $\mu\text{g}/\text{cm}^2\cdot\text{h}$, scopolamine 2-8 $\mu\text{g}/\text{cm}^2\cdot\text{h}$, estradiol 0.01-0.03 $\mu\text{g}/\text{cm}^2\cdot\text{h}$, clonidine 0.5 $\mu\text{g}/\text{cm}^2\cdot\text{h}$, and nicotine 100-300 $\mu\text{g}/\text{cm}^2\cdot\text{h}$. However, nicotine is also very irritating to skin and is very toxic. Therefore, development of acceptable TDD devices for delivering nicotine has required finding ways to minimize the irritation and safety problems while supplying effective doses of the substance.

A number of TDD devices for delivering nicotine have been described. Japanese Laid Open Application No. 61-251619 reports a non-controlled release device that holds low amounts of the substance and covers a relatively large area (70 cm^2) of skin. U.S. Patent No. 4,597,961 to Etscorn discloses a device in which a microporous membrane minimally controls release of nicotine to the skin such that it is effective for only about 45 minutes. U.S. Patent Nos. 4,920,989 and 5,016,652 to Rose et al. describe a nicotine patch that is preferably used with a nicotine aerosol spray that is delivered into a patient's mouth. U.S. Patent No. 4,943,435 to Baker et al. reports a transdermal patch for delivering nicotine for periods

of 12-24 hours that includes a nicotine reservoir and rate-controlling polymer matrix to regulate nicotine diffusion through the skin. U.S. Patent No. 4,908,213 to Govil et al. discloses a transdermal nicotine patch containing an antipruritic to counteract severe itching that may occur with transdermal administration of nicotine. U.S. Patent No. 4,877,618 to Reed teaches a transdermal nicotine patch containing a stack of alternating adhesive and interlaminar layers for providing a relatively constant rate of diffusion through the skin over an extended period of time.

Methods of fabricating TDD devices have not received much attention in the patent literature. U.S. Patent No. 4,943,435 to Baker et al. discloses a method of making a nicotine patch wherein the nicotine is preferably dissolved in an inert polymer matrix that controls the rate of nicotine release. The percentage by weight of nicotine can be varied according to the desired loading in the monolithic matrix layer, however, above about 50% nicotine by weight the polymer fails to solidify properly after casting, remaining in a gel or fluid form. Thus, this method of making nicotine patches is limited to polymers and nicotine loads that, when mixed, polymerize properly.

Another problem of drug delivery devices containing polymers and volatile drugs is that, even if polymerization is achieved in the presence of the drug, the polymer-drug combination must be allowed to dry. This is a problem for volatile drugs, such as nicotine, since the concentration of the volatile drug will diminish during drying, especially if the polymer is heated in an oven to accelerate drying. Thus, it would be advantageous to avoid fabrication methods requiring heating or drying after addition of a volatile drug to the polymer.

Explore Litigation Insights

Docket Alarm provides insights to develop a more informed litigation strategy and the peace of mind of knowing you're on top of things.

Real-Time Litigation Alerts



Keep your litigation team up-to-date with **real-time alerts** and advanced team management tools built for the enterprise, all while greatly reducing PACER spend.

Our comprehensive service means we can handle Federal, State, and Administrative courts across the country.

Advanced Docket Research



With over 230 million records, Docket Alarm's cloud-native docket research platform finds what other services can't. Coverage includes Federal, State, plus PTAB, TTAB, ITC and NLRB decisions, all in one place.

Identify arguments that have been successful in the past with full text, pinpoint searching. Link to case law cited within any court document via Fastcase.

Analytics At Your Fingertips



Learn what happened the last time a particular judge, opposing counsel or company faced cases similar to yours.

Advanced out-of-the-box PTAB and TTAB analytics are always at your fingertips.

API

Docket Alarm offers a powerful API (application programming interface) to developers that want to integrate case filings into their apps.

LAW FIRMS

Build custom dashboards for your attorneys and clients with live data direct from the court.

Automate many repetitive legal tasks like conflict checks, document management, and marketing.

FINANCIAL INSTITUTIONS

Litigation and bankruptcy checks for companies and debtors.

E-DISCOVERY AND LEGAL VENDORS

Sync your system to PACER to automate legal marketing.