



US006553130B1

(12) **United States Patent**
Lemelson et al.

(10) **Patent No.:** **US 6,553,130 B1**
(45) **Date of Patent:** **Apr. 22, 2003**

(54) **MOTOR VEHICLE WARNING AND CONTROL SYSTEM AND METHOD** JP 4-219900 8/1992 340/903
JP 5-124529 5/1993
JP 5-143897 6/1993 340/903

(76) Inventors: **Jerome H. Lemelson**, 868 Tyner Way, Incline Village, NV (US) 89450;
Robert Pedersen, 7808 GlenEagle, Dallas, TX (US) 75248

OTHER PUBLICATIONS

Abu-Mostafa, "Information Theory, Complexity, and Neural Networks," *IEEE Communications*, pp. 25-28 (Nov. 1989).
Aggarwal et al., "On the Computation of Motion from Sequences of Images—A Review," *Proceedings of the IEEE*, pp. 917-35 (Aug. 1988).

(*) Notice: Subject to any disclaimer, the term of this patent is extended or adjusted under 35 U.S.C. 154(b) by 1543 days.

(21) Appl. No.: **08/671,853**

(List continued on next page.)

(22) Filed: **Jun. 28, 1996**

Related U.S. Application Data

(63) Continuation of application No. 08/105,304, filed on Aug. 11, 1993, now abandoned.

Primary Examiner—Timothy M. Johnson
(74) *Attorney, Agent, or Firm*—Louis J. Hoffman

(51) **Int. Cl.⁷** **G06K 9/00**
(52) **U.S. Cl.** **382/104; 340/435; 340/436; 340/903; 382/106**

(57) **ABSTRACT**

A system and method assists the driver of a motor vehicle in preventing accidents or minimizing the effects of same. In one form, a television camera is mounted on a vehicle and scans the roadway ahead of the vehicle as the vehicle travels. Continuously generated video picture signals output by the camera are electronically processed and analyzed by an image analyzing computer, which generates codes that serve to identify obstacles. A decision computer mounted in the controlled vehicle receives such code signals along with code signals generated by the speedometer or one or more sensors sensing steering mechanism operation and generates control signals. Such code signals may be displayed, and a synthetic speech or special sound generating and warning means used, to warn the driver of the vehicle of approaching and existing hazards. The system may also use the control signals, particularly through application of fuzzy logic, to control the operation of the brakes and steering mechanism of the vehicle to avoid or lessen the effects of a collision. In a particular form, the decision computer may select the evasive action taken from a number of choices, depending on whether and where the detection device senses other vehicles or obstacles.

(58) **Field of Search** 348/113, 114, 348/115, 116, 118, 119, 135, 139, 140, 142, 148, 149; 382/104, 215, 209, 106, 156, 103, 217, 218; 340/907, 435, 903, 901, 436; 180/168, 169, 167, 271, 274, 275; 364/424.02, 460, 461, 436-437, 425.04, 425.01, 426.01, 443, 424.032; 395/905, 900, 913

(56) **References Cited**

U.S. PATENT DOCUMENTS

4,257,703 A 3/1981 Goodrich 356/4
4,626,850 A 12/1986 Chey 340/903
4,825,211 A 4/1989 Park 340/901
4,872,051 A 10/1989 Dye 340/903

(List continued on next page.)

FOREIGN PATENT DOCUMENTS

JP 4-15799 1/1992 340/905

55 Claims, 13 Drawing Sheets

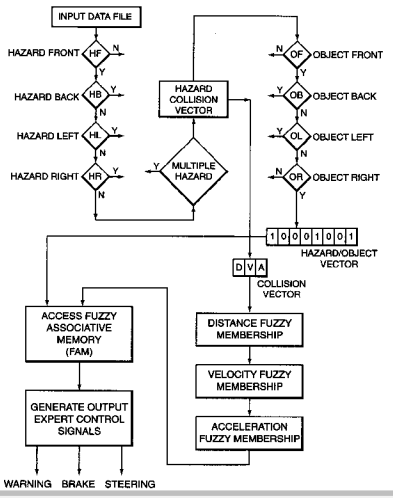

U.S. PATENT DOCUMENTS

4,901,362	A	*	2/1990	Terzian	382/103
4,926,170	A		5/1990	Beggs et al.	340/904
4,931,937	A	*	6/1990	Kakinami et al.	180/169
4,933,852	A		6/1990	Lemelson	340/439
4,969,038	A		11/1990	Lemelson	358/107
4,979,029	A		12/1990	Lemelson	358/93
5,018,689	A		5/1991	Yasunobu et al.	395/905
5,039,217	A		8/1991	Maekawa et al.	356/1
5,081,585	A		1/1992	Kurami et al.	364/424.02
5,091,726	A		2/1992	Shyu	340/904
5,122,796	A		6/1992	Beggs et al.	340/904
5,146,219	A		9/1992	Zechall	340/905
5,161,107	A		11/1992	Mayeaux et al.	340/937
5,164,904	A		11/1992	Summer	340/905
5,177,462	A		1/1993	Kajiwara	340/903
5,179,377	A		1/1993	Hancock	340/961
5,189,619	A		2/1993	Adachi et al.	395/905
5,197,562	A	*	3/1993	Kakinami et al.	180/169
5,230,400	A		7/1993	Kakinami et al.	180/169
5,249,157	A		9/1993	Taylor	340/903
5,276,620	A		1/1994	Bottesch	364/424.05
5,278,764	A		1/1994	Iizuka et al.	364/461
5,298,882	A		3/1994	Tsai	340/468
5,304,980	A		4/1994	Maekawa	340/903
5,307,136	A		4/1994	Saneyoshi	180/167
5,314,037	A		5/1994	Shaw et al.	180/169
5,327,117	A		7/1994	Kohsaka	340/459
5,332,057	A		7/1994	Butsuen et al.	180/169
5,339,075	A		8/1994	Abst et al.	340/903
5,341,344	A		8/1994	O'Brien et al.	367/96
5,357,438	A		10/1994	Davidian	180/169
5,369,591	A		11/1994	Broxmeyer	340/903
5,545,960	A	*	8/1996	Ishikawa	364/424.032

OTHER PUBLICATIONS

Alspector, "Neural-Style Microsystems that Learn," *IEEE Communications*, pp. 29–36 (Nov. 1989).

Casasent, "Optics and Neural Nets," Chapter 16 in Carpenter et al., eds., *Neural Networks for Vision and Image Processing*, pp. 437–48, (MIT Press 1992).

Cox, "Fuzzy Fundamentals," *IEEE Spectrum*, pp. 58–61 (Oct. 1992).

Hammerstrom, "Neural Networks at Work," *IEEE Spectrum*, pp. 26–32 (Jun. 1993).

Hush et al., "Progress in Supervised Neural Networks," *IEEE Signal Processing*, pp. 8–39 (Jan. 1993).

Jurgen, "Smart Cars and Highways Go Global," *IEEE Spectrum*, pp. 26–36 (May 1991).

Kittler et al., eds., *Image Processing System Architectures*, Chapter 4, pp. 49–81, and Chapter 5, pp. 85–101 (John Wiley & Sons 1985).

Kosko et al., "Fuzzy Logic," *Scientific American*, pp. 76–81 (Jul. 1993).

Lee, "Fuzzy Logic in Control Systems: Fuzzy Logic Controller, Part II," *IEEE Transaction on Systems, Man, and Cybernetics*, pp. 419–435 (vol. 20, No. 2, Mar./Apr. 1990).

Lippmann, "An Introduction to Computing with Neural Nets," *IEEE ASSP*, pp. 4–22 (Apr. 1987).

Lippmann, "Pattern Classification Using Neural Networks," *IEEE Communications*, pp. 47–50, 59–64 (Nov. 1989).

Lisboa, ed., *Neural Networks—Current Applications*, Chapter 1, pp. 1–34, Chapter 2, pp. 35–48, Chapter 7, pp. 123–147 (Chapman & Hall 1992).

Lupo, "Defense Applications of Neural Networks," *IEEE Communications*, pp. 82–88 (Nov. 1989).

Maresca et al., "Parallel Architectures for Vision," *Proceedings of the IEEE*, pp. 970–981 (vol. 76, No. 8, Aug. 1988).

Nijhuis et al., "Evaluation of Fuzzy and Neural Vehicle Control," *Institution of Electrical Engineers*, pp. 447–452 (1992).

Pearson, ed., *Image Processing*, Chapter 8, pp. 141–155, and Chapter 10, pp. 169–189 (McGraw-Hill 1991).

Psaltis et al., "Optoelectronic Implementations of Neural Networks," *IEEE Communications*, pp. 37–40, 71 (Nov. 1989).

Roth, "Neural Networks for Extraction of Weak Targets in High Clutter Environments," *IEEE Transactions on Systems, Man, and Cybernetics*, pp. 1210–1217 (Sep./Oct. 1989).

Schwartz et al., "Fuzzy Logic Flowers in Japan," *IEEE Spectrum*, pp. 32–35 (Jul. 1992).

Soucek et al., *Neural and Massively Parallel Computers*, Chapter 12, pp. 245–276 (John Wiley & Sons 1988).

Suaya et al., eds., *VLSI and Parallel Computation*, Chapter 1, pp. 1–84, and Chapter 5, pp. 390–415 (Morgan Kaufmann 1990).

Teuber, *Digital Image Processing*, Chapter 1, pp. 1–30, Chapter 2, pp. 31–70, and Appendix D, pp. 254–255 (Prentice Hall 1993).

Wasserman, *Neural Computing: Theory and Practice*, Chapter 1, pp. 11–26, Chapter 2, pp. 27–42, Chapter 3, pp. 43–59, and Chapter 9, pp. 151–166 (Van Nostrand Reinhold 1989).

Yuhas et al., "Integration of Acoustic and Visual Speech Signals Using Neural Networks," *IEEE Spectrum*, pp. 65–71 (Nov. 1989).

Shekhar et al., Design and Validation of Head up Displays for Navigation in IVHS, *VNIS'91*, Oct. 1991, pp. 537–542.

"NHTSA IVHS Plan," National Highway Safety Administration U.S. Department of Transportation, Jun. 12, 1992.

Bosacchi et al, Fuzzy Logic Technology & the Intelligent Highway System (IHS); *IEEE*, 1993, pp. 65–70.

Rock et al., "Intelligent Road Transit: The Next Generation," *AI EXPERT*, Apr. 1994, pp. 16–24 (not prior art).

* cited by examiner

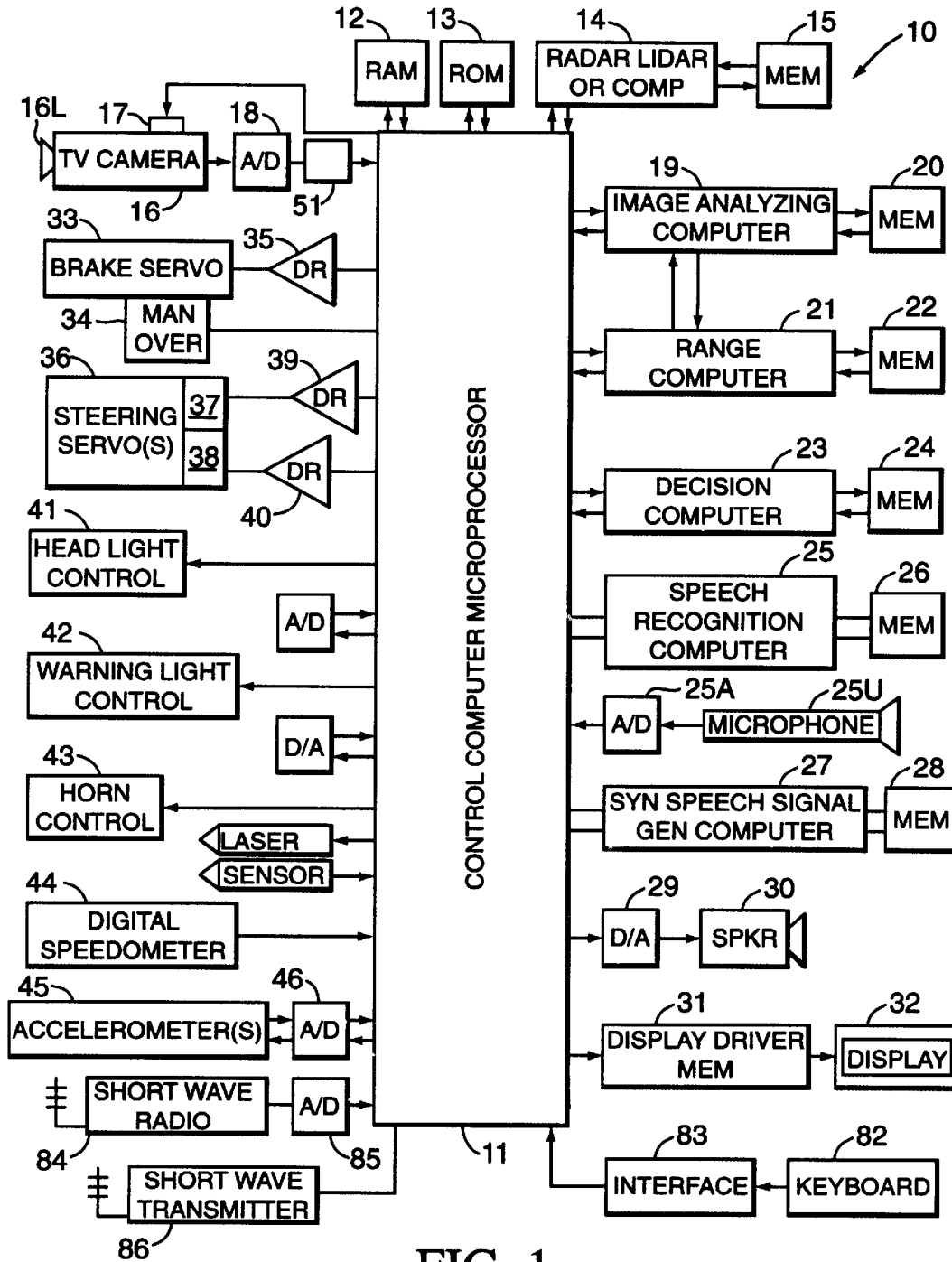

FIG. 1

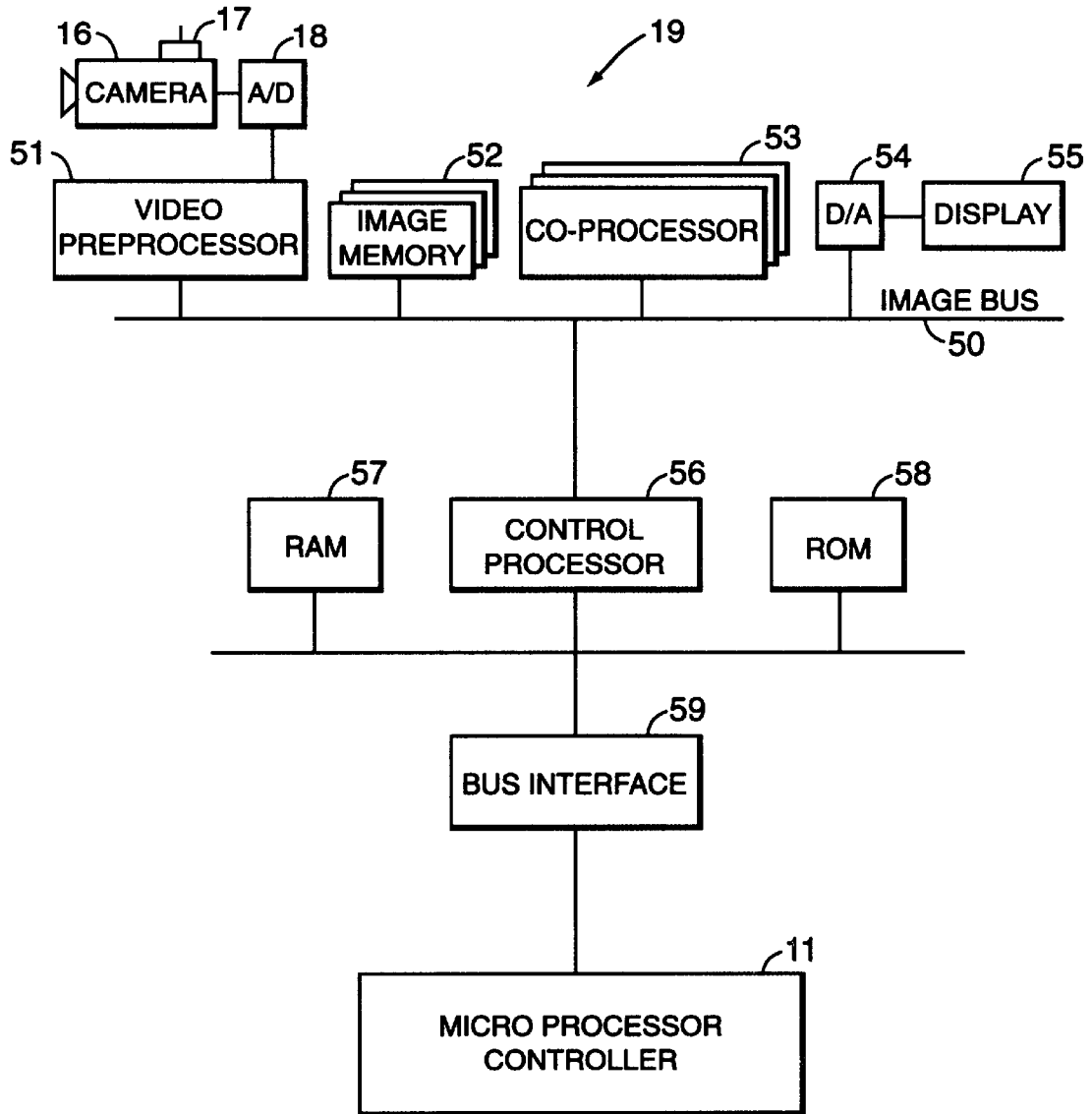

FIG. 2

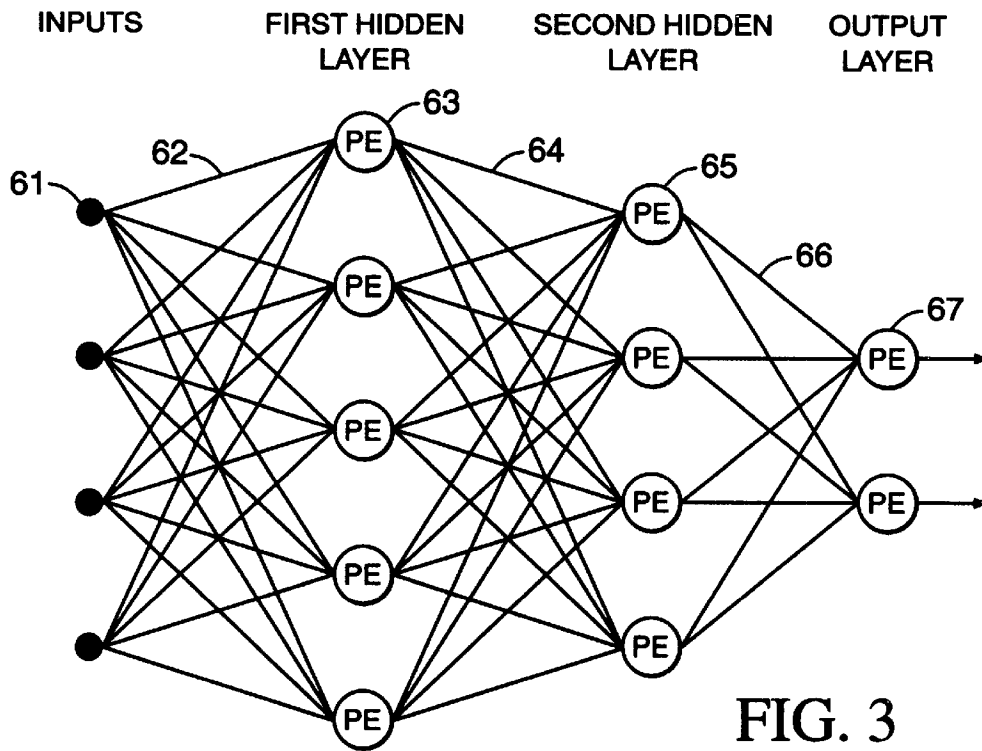

FIG. 3

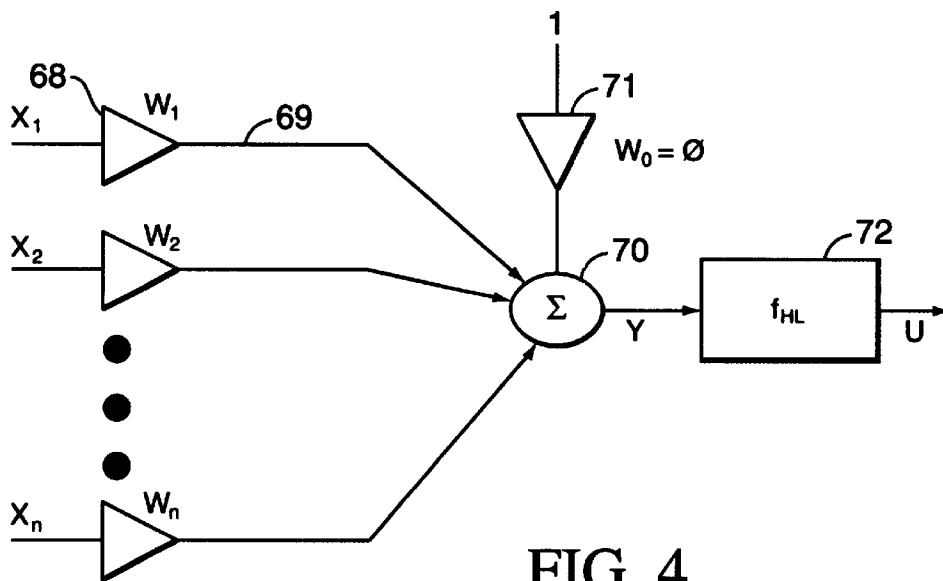

FIG. 4

Explore Litigation Insights

Docket Alarm provides insights to develop a more informed litigation strategy and the peace of mind of knowing you're on top of things.

Real-Time Litigation Alerts



Keep your litigation team up-to-date with **real-time alerts** and advanced team management tools built for the enterprise, all while greatly reducing PACER spend.

Our comprehensive service means we can handle Federal, State, and Administrative courts across the country.

Advanced Docket Research



With over 230 million records, Docket Alarm's cloud-native docket research platform finds what other services can't. Coverage includes Federal, State, plus PTAB, TTAB, ITC and NLRB decisions, all in one place.

Identify arguments that have been successful in the past with full text, pinpoint searching. Link to case law cited within any court document via Fastcase.

Analytics At Your Fingertips



Learn what happened the last time a particular judge, opposing counsel or company faced cases similar to yours.

Advanced out-of-the-box PTAB and TTAB analytics are always at your fingertips.

API

Docket Alarm offers a powerful API (application programming interface) to developers that want to integrate case filings into their apps.

LAW FIRMS

Build custom dashboards for your attorneys and clients with live data direct from the court.

Automate many repetitive legal tasks like conflict checks, document management, and marketing.

FINANCIAL INSTITUTIONS

Litigation and bankruptcy checks for companies and debtors.

E-DISCOVERY AND LEGAL VENDORS

Sync your system to PACER to automate legal marketing.