



July 8, 2014

Certification

Park IP Translations

This is to certify that the attached translation is, to the best of my knowledge and belief, a true and accurate translation from Japanese into English of: Japanese Unexamined Patent Application Publication Number, H2-36417.

Hanna Kang

Project Manager

Project Number: OSLI_1406_017

15 W. 37th Street 8th Floor
New York, NY 10018
212.581.8870

(19) Japan Patent Office (JP)

(11) Japanese Patent Number

(12) **Japanese Patent Publication** (B2)

H2-36417

(51) Int. Cl.⁵
B 60 R 1/00

Identification codes

JPO file numbers
7812-3D

(24) (44) Publication date August 17, 1990

Number of inventions: 1 (Total of 4 pages)

(54) Title of the invention	VEHICLE REARVIEW MONITORING DEVICE	(65) Examined Publication yes
	(21) Japanese Patent Application	S57-220222 S59-114139
	(22) Date of Application	December 17, 1982 (43) July 2, 1984
(72) Inventor	SUZUKI, Kenji	% NILES PARTS CO LTD 5-28-6 Omori Nishi, Ota-ku, Tokyo
(71) Applicant	NILES PARTS CO LTD	5-28-6 Omori Nishi, Ota-ku, Tokyo
(74) Agent	Patent attorney MATSUDA, Katsuji	
Examiner:	FUKAZAWA Michitaru	

The applicant has a license of right.

(56) Reference Document: Japanese Unexamined Utility Model Registration Application Publication S49-96819 (JP, U)
Japanese Unexamined Utility Model Registration Application Publication S57-188544 (JP, U)

(57) SCOPE OF PATENT CLAIMS

1. A vehicle rearview monitoring device comprising:

a television camera 1 for monitoring to the rear of the vehicle;

a monitor television 2, provided at the driver's seat, for displaying video captured by the television camera 1;

a sensor 6 for outputting an information signal regarding the travel of the vehicle, including distance between the vehicle and an obstacle to the rear, the tire steering angle, and the speed of travel; and

a marker signal generating circuit 7 for inputting the information signal from the sensor 6 to generate a marker signal in response to the information signal, to output, to the monitor television 2, to electrically superimpose a marker on the television screen.

[DETAILED EXPLANATION OF THE INVENTION]

The present invention relates to a vehicle rearview monitoring device.

In fastback-style sports cars, large buses, trailers, and the like, it is difficult to secure an adequate rearward field of view through the rearview mirrors, back mirrors, and the like, and so to compensate for this shortcoming, conventionally there has been a proposal for a rearview system that combines a CTV camera 1 and a monitor television 2, as illustrated in FIG. 1. However, in this type of conventional system, that which is to the rear of the vehicle is simply displayed on the monitor television 2 at the driver's

seat, so it has been difficult for the driver to get a sense of distance, and visually gauging the distance has led to errors, leading to numerous accidents such as collisions with obstacles or striking pedestrians while backing.

Given this, there has also been a proposal for several distance markers 4 corresponding to the width of the vehicle, on the screen 3 of the monitor television 2 at the driver's seat, as illustrated in FIG. 2 a and b, but these distance markers 4 were no more than printed dots on a transparent panel 5, and attaching this panel to the screen 3 of the monitor television 2, where the markers 4 had no relationship whatsoever with the displayed content, where even in cases wherein obstacles are displayed large on the screen, or when backing when cutting a curve, the markers 4 were merely displayed statically at specific positions on the screen, making it impossible to evaluate the distance, or the rearward direction, accurately through the markers 4, and while they led to awareness, the function as indicators has not been adequate.

The present invention was proposed in contemplation of the shortcomings described above, and the object thereof is to provide a vehicle rearview monitoring device that electrically superimposes a number of markers on a television monitor screen to enable the display locations thereof, thus enabling the display locations to be changed arbitrarily as necessary, and enabling the markers 4 to be changed

as appropriate depending on whether or not there is an obstacle or pedestrian, the position thereof and the direction of travel of the vehicle, the vehicle speed, and the like, to enable the driver to gain a proper sense of distance, and to know accurately the state to the rear of the vehicle.

Based on an embodiment according to the present invention, illustrated in the figures, the structure of the present invention will be described below.

FIG. 3 is a block diagram of one embodiment according to the present invention, where, as can be appreciated from the block diagram, this embodiment is structured from a CTV camera 1 for monitoring to the rear of the vehicle, a monitor television 2 that is disposed at the driver's seat, a sensor 6 for sensing the distance to a rearward obstacle, the vehicle speed, the rearward direction, and the like, and a marker signal generating circuit 7 for inputting a signal from the sensor 6 and for generating the required marker signal, where this marker signal generating circuit 7 is structured from a CPU (Central Processing Unit) 8, a ROM (Read Only Memory) 9, and an interface 10.

Note that the sensors may be selected from a variety of types depending on the state of display of the markers, but one may consider, for example, a distance sensor for measuring the distance between the vehicle and a rearward obstacle, a tire direction sensor for discerning the rearward travel direction, a velocity sensor for measuring the vehicle speed, and the like. These may be selected arbitrarily as necessary. However, in this case data must be stored, of course, in the ROM 9 depending on the various functions of the sensors.

The structure of the present invention is as described above, and when explaining the operation when a distance sensor is used as the sensor 6, then, as illustrated in FIG. 4, if there is an obstacle 11 to the rear of the vehicle, the distance sensor measures the distance from the vehicle to the rearward obstacle, and that distance data is inputted into the CPU 8 of the marker signal generating circuit 7, where display data that is stored in the ROM 9 is referenced, and display data retrieved from the ROM 9 is outputted to the monitoring device 2 through an interface 10, to display, on the screen of the monitor television 3, the rearward obstacle 11, as illustrated in FIG. 5, with the markers 4 displayed superimposed thereon. That is, if, for example, display data for displaying one marker for each 1 meter were stored in the ROM 9, then when the distance sensor 6 measures the distance to the rearward obstacle 11 as 2 m, then display data so as to display to markers, at 1 m each, is retrieved from the ROM 9 and two of these markers are displayed on the screen of the monitor television 2.

Note that the superimposed display of the markers on the screen of the monitor television 2 may (1) erase markers that are further away when an obstacle is near; (2) reduce the spacing between markers between the vehicle and the obstacle when the obstacle is nearer than a predetermined distance; and (3) change the color of the display of the markers when the obstacle is nearer than a distance that has been set in advance. Obviously these can be performed freely through storing display data in the ROM 9. Note that the example illustrated in FIG. 5 is for the state of the display in (1), above.

When a distance sensor is used as the sensor 6, there is the effect of being able to change the marker as appropriate depending on the distance to the obstacle, to provide the driver with an accurate sense of the rearward distance, to warn of an unusually close proximity to an obstacle, to display accurately the distance to an obstacle, to avoid collisions with obstacles due to an incorrect sense of distance, such as has occurred in the past, and to avoid the risk of striking a child who is playing behind the vehicle, enabling the vehicle to be backed up safely.

Moreover, when a tire direction sensor, which detects the steering angle, is used as the sensor, then if markers are used to display the forecasted path of the vehicle when backing up, marker position data following the rearward direction of the vehicle corresponding to the steering angle data for the tires in regards to the rearward direction of the vehicle may be stored in advance in the ROM 9, and when steering angle data is inputted from the tire direction sensor, marker position data may be retrieved from the ROM 9 in accordance therewith. Moreover, the marker position data that has been retrieved may be sent to the monitor television 2 through the interface 10, to be displayed superimposed on the screen as a line of markers 3. That is, in this case the markers are displayed biased by the anticipated rearward direction path of the vehicle, as illustrated in FIG. 6 a, b, and c, to display clearly the rearward direction of the vehicle. Furthermore, if a speed sensor for measuring the speed of the vehicle is used in parallel as this sensor, then the markers can be changed not only depending on the backing time, but also depending on the speed of rearward travel, where, for example, the spacing of the markers may be at 2 meter intervals when traveling with a vehicle speed of 10 km/h, or 50 meter intervals when traveling with a vehicle speed of 100 km/h. Furthermore, as with the embodiments described above, rather than just a single sensor, a plurality of sensors may be used in parallel, such as a distance sensor and a tire direction sensor, where, depending on the capacity of the ROM and the CPU, various types of sensors may be used,

and the markers on the monitor television screen may be varied in a variety of ways.

The vehicle rearview monitoring device according to the present invention is provided with a marker signal generating circuit for displaying the masses on markers superimposed electrically on the television screen depending on information signals pertaining to the travel of the vehicle, outputted by the sensors as described above, thus enabling the display locations and display directions of the markers on the screen of the television to be changed freely depending on the information obtained from the sensors.

For example, when a distance sensor is used as the sensor, the state of display of the markers can be changed depending on the distance to the rearward obstacle, detected by the distance sensor, where the markers may be removed if the distance to the obstacle is far, or the markers may be indicated as appropriate depending on the situation, such as changing the colors of the markers or the spacing between the markers depending on the distance to an obstacle.

Moreover, when the tire direction sensor is used as the sensor, then the predicted path of the vehicle, corresponding to the width of the vehicle, when backing, indicated by the markers, may be changed in response to the tire steering angle data, to thereby enable the rearward direction of the vehicle to be checked, or enabling easy checking as to whether or not a vehicle can, for example, fit into a parking space that is to the rear.

Furthermore, when a speed sensor is used as the sensor, the spacing between the markers can be changed depending on the speed of travel detected by the speed sensor, thereby enabling the distance

between vehicles that is required for safe travel to be checked by the spacing of the markers.

In this way, the vehicle rearview monitoring device according to the present invention has the superior effects of not only enabling the driver to check the rearward field of view, but also to appropriately understand the distance to a rearward obstacle, the rearward travel direction, and the like through appropriate marker indicators, enabling backing operations to be performed safely and confidently.

BRIEF DESCRIPTIONS OF THE DRAWINGS

FIG. 1 is an explanatory diagram of a vehicle rearview monitor using a conventional television camera and monitor television. FIG. 2 a is a perspective diagram of a monitor television that uses conventional markers. FIG. 2 b is a plan view diagram thereof. FIG. 3 is a block diagram of one embodiment according to the present invention. FIG. 4 is a perspective diagram of the rearward situation for a vehicle. FIG. 5 is an explanatory diagram for video of a monitor television when backing a vehicle. FIG. 6 a, b, and c are explanatory diagrams of video for the monitor television when using a tire direction sensor as the sensor.

- 1: CTV Camera
- 2: Monitor Television
- 3: Screen
- 4: Distance Marker
- 5: Panel
- 6: Sensor
- 7: Marker Signal Generating Circuit
- 8: CPU
- 9: ROM
- 10: Interface
- 11: Obstacle

FIG. 1

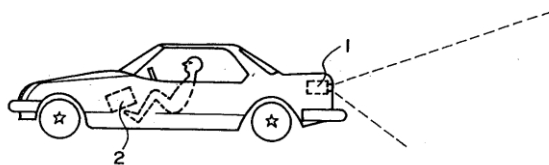

FIG. 2

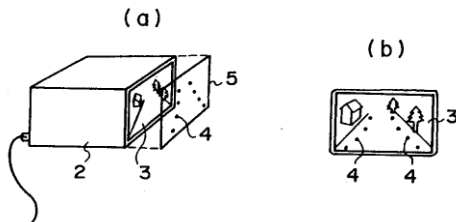

FIG. 3

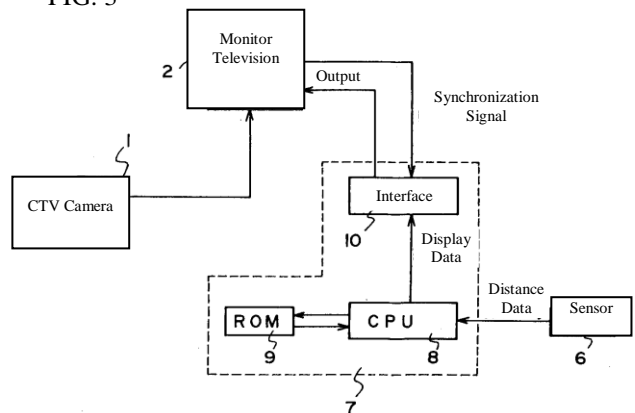

FIG. 4

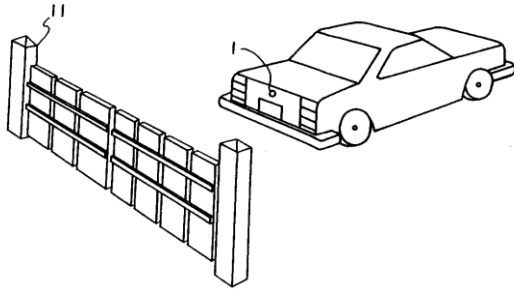

FIG. 5

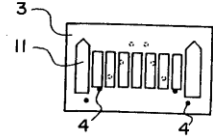

FIG. 6

