



US008532231B2

(12) **United States Patent**
Yu et al.

(10) **Patent No.:** **US 8,532,231 B2**
(45) **Date of Patent:** **Sep. 10, 2013**

(54) **APPARATUS FOR TRANSMITTING AND RECEIVING DATA TO PROVIDE HIGH-SPEED DATA COMMUNICATION AND METHOD THEREOF**

(58) **Field of Classification Search**
USPC 375/340, 267, 299, 260; 455/101; 370/240
See application file for complete search history.

(75) Inventors: **Hee-Jung Yu**, Daejeon (KR); **Taehyun Jeon**, Sungnam (KR); **Myung-Soon Kim**, Daejeon (KR); **Eun-Young Choi**, Daejeon (KR); **Sok-Kyu Lee**, Daejeon (KR); **Deuk-Su Lyu**, Daejeon (KR)

(56) **References Cited**

U.S. PATENT DOCUMENTS

6,950,483 B2 * 9/2005 Chiodini 375/354
7,020,110 B2 * 3/2006 Walton et al. 370/334

(Continued)

FOREIGN PATENT DOCUMENTS

KR 10-2002-0086167 * 11/2002
KR 10-2004-0016672 * 2/2004

(Continued)

OTHER PUBLICATIONS

Allert van Zelst et al., "Implementation of a MIMO OFDM-Based Wireless LAN System", IEEE Transactions on signal processing, vol. 52, No. 2, Feb. 2004, pp. 483-494.*

(Continued)

Primary Examiner — Juan A Torres

(74) Attorney, Agent, or Firm — Hunton & Williams LLP

(73) Assignee: **Electronics and Telecommunications Research Institute**, Daejeon (KR)

(*) Notice: Subject to any disclaimer, the term of this patent is extended or adjusted under 35 U.S.C. 154(b) by 0 days.

(21) Appl. No.: **13/292,715**

(22) Filed: **Nov. 9, 2011**

Prior Publication Data

US 2012/0051474 A1 Mar. 1, 2012

Related U.S. Application Data

(60) Division of application No. 12/805,117, filed on Jul. 13, 2010, now Pat. No. 8,130,869, which is a continuation of application No. 12/401,293, filed on Mar. 10, 2009, now Pat. No. 7,782,968, which is a continuation of application No. 11/767,797, filed on Jun. 25, 2007, now Pat. No. 7,535,968.

Foreign Application Priority Data

Dec. 23, 2004 (KR) 10-2004-0111065
Feb. 11, 2005 (WO) PCT/KR2005/000393

(51) **Int. Cl.**
H04L 27/06 (2006.01)

(52) **U.S. Cl.**
USPC **375/340; 375/267; 375/299; 375/260; 455/101; 370/240**

(57) **ABSTRACT**

In the present invention, data generated from a source unit are distributed to at least one bandwidth; the data distributed to the respective bandwidths are encoded in order to perform an error correction; the encoded data are distributed to at least one antenna; a subcarrier is allocated to the data distributed to the respective antennas, and an inverse Fourier transform is performed; a short preamble and a first long preamble corresponding to the subcarrier are generated; a signal symbol is generated according to a data transmit mode; and a frame is generated by adding a second long preamble between the signal symbol and a data field for the purpose of estimating a channel of a subcarrier which is not used.

59 Claims, 9 Drawing Sheets

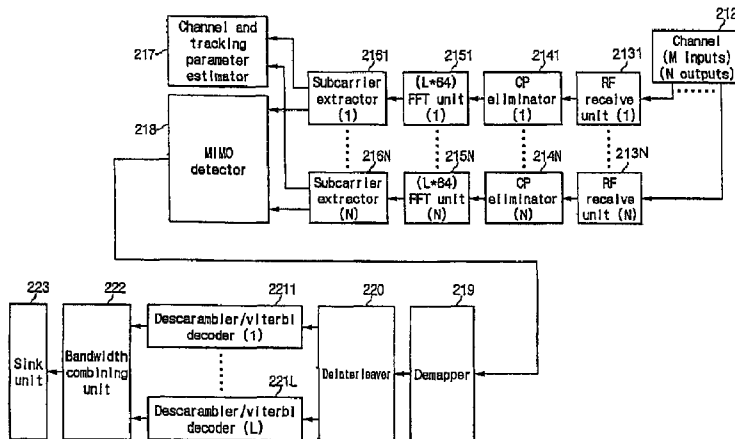

(56)

References Cited

U.S. PATENT DOCUMENTS

7,050,768	B2 *	5/2006	Hosur et al.	455/103
7,352,688	B1 *	4/2008	Perahia et al.	370/206
7,366,250	B2 *	4/2008	Mujtaba et al.	375/267
7,408,976	B1 *	8/2008	Narasimhan et al.	375/148
7,415,074	B2 *	8/2008	Seto et al.	375/260
7,796,681	B1 *	9/2010	Narasimhan et al.	375/148
2002/0160737	A1 *	10/2002	Crawford	455/272
2003/0072255	A1 *	4/2003	Ma et al.	370/208
2003/0072452	A1 *	4/2003	Mody et al.	380/274
2004/0105506	A1 *	6/2004	Baek et al.	375/260
2005/0054313	A1 *	3/2005	Gummadi et al.	455/226.1
2005/0163081	A1 *	7/2005	Aoki et al.	370/334
2005/0233709	A1 *	10/2005	Gardner et al.	455/101
2005/0276347	A1 *	12/2005	Mujtaba et al.	375/299
2005/0288062	A1 *	12/2005	Hammerschmidt et al.	455/562.1
2006/0002487	A1 *	1/2006	Kriedte et al.	375/267
2006/0251193	A1 *	11/2006	Kopmeiners et al.	375/345
2009/0310702	A1 *	12/2009	Lewis	375/267

FOREIGN PATENT DOCUMENTS

KR	10-2004-0077279	*	4/2004
KR	10-2004-0047699	*	5/2004
KR	10-2004-0062266	*	7/2004
KR	10-2004-0077569	*	4/2007

OTHER PUBLICATIONS

Jaiganesh Balakrishnan et al., "A multi-band OFDM system for UWB communication", Apr. 3, 2003, pp. 354-358.*

Butler, Michael R.G. et al. A Zero-Forcing Approximate Log-Likelihood Receiver for MIMO Bit-Interleaved Coded Modulation. IEEE Communications Letters, vol. 8, No. 2 Feb. 2004.*

Yu, Heejung et al. ETRI proposal specification for IEEE 802.11 TGn. Aug. 13, 2004.*

International Search Report for PCT/KR2005/000393, mailed Sep. 30, 2005.*

Markarian et al., OFDM mode for the IEEE 802.16a PHY draft standard, IEEE May 17, 2001, 59 pages.*

IEEE802.11a, "Part 11: Wireless LAN Medium Access Control (MAC) and Physical Layer (PHY) specifications High-speed Physical Layer in the 5 GHz Band", IEEE 1999 pp. 1-45.*

Liu, "A MIMO system with backward compatibility for OFDM based WLANs", 4th IEEE Workshop on Signal Processing Advances in Wireless Communications, 2003, SPAWC 2003, Jun. 15-18, 2003 pp. 130-134.*

Jianhua Liu et al., "A MIMO system with backward compatibility for OFDM based WLANs", Signal Processing Advances in Wireless Communications, 2003 (SPAWC 2003), Jun. 15, 2003, pp. 130-134.*

Eric G Larsson et al., "Preamble Design for Multiple-Antenna OFDM-Based WLANs with Null Subcarriers", IEEE Signal Processing Letters, vol. 8, No. 11, Nov. 1, 2001.*

IEEE, "Information technology—telecommunications and information exchange between systems—local and metropolitan area networks—specific requirements/Part 11: Wireless LAN Medium Access Control (MAC) and Physical Layer (PHY) specifications/Amendment 1: high-speed physical layer in the 5 GHz band", IEEE Standard (International Standard ISO).*

Ogawa, "A MIMO-OFDM system for high-speed transmission", 2003 IEEE 58th Vehicular Technology Conference, 2003, VTC 2003-Fall, vol. 1, Oct. 6-9, 2003 pp. 493-497 vol. 1.*

Boer, "Backwards Compatibility, How to make a MIMO-OFDM system backwards compatible and coexistence with 11 a/g at the link level", Sep. 15, 2003. 26 Pages.*

European Search Report dated Oct. 27, 2009 and issued in corresponding European Patent Application 05726596.9 1.*

Liu, J., et al. A Mimo System with Backward Compatibility for OFDM Based WLAN, 4th IEEE Workshop on Signal Processing Advance in Wireless Communications, pp. 130-134, dated 2003.

Larsson, E. G. et al., Preamble Design for Multiple-Antenna OFDM-Based WLANs With Null Subcarriers, IEEE Signal Processing Letters, pp. 286-288 vol. 8, No. 11, Nov. 2001.

Information Technology—Telecommunications and information exchange between systems—Local and metropolitan area networks—Specific requirements—Part 11: Wireless LAN Medium Access Control (MAC) and Physical Layer (PHY) specifications Amendment 1: High-speed Physical Layer in the 5 GHz band, pp. 40 International Standard ISO/IEC 8802-11;1999/Amd 1:2000(E).

Mujtaba, Syed A. "TGn Sync Proposal Technical Specification", Nov. 4th, 2004.

* cited by examiner

Fig. 1
(PRIOR ART)

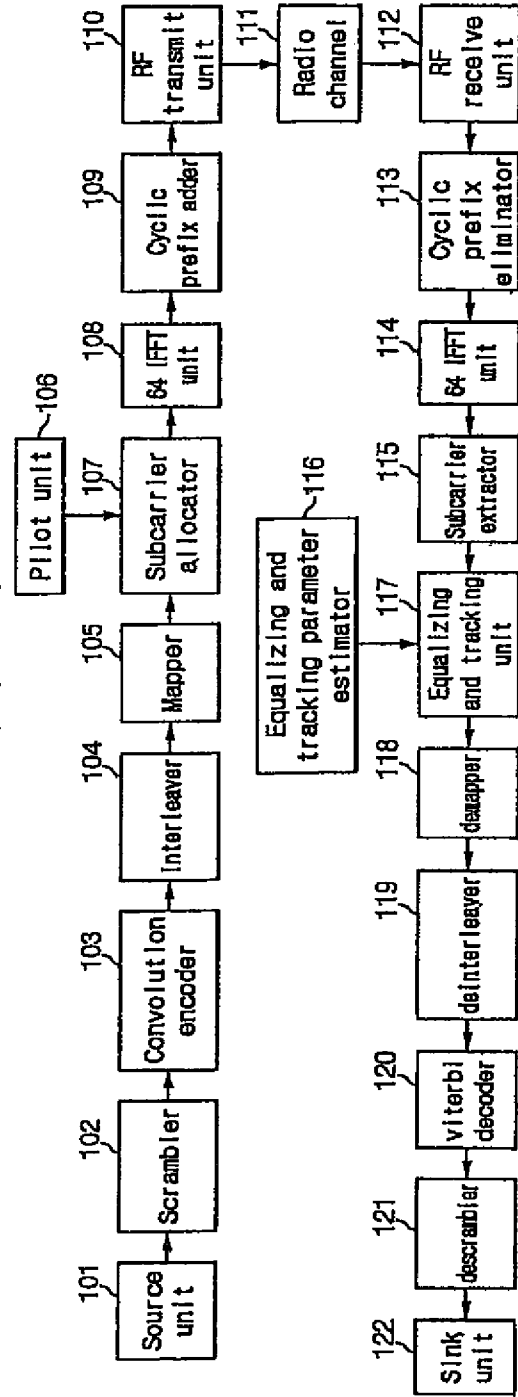

Fig. 2

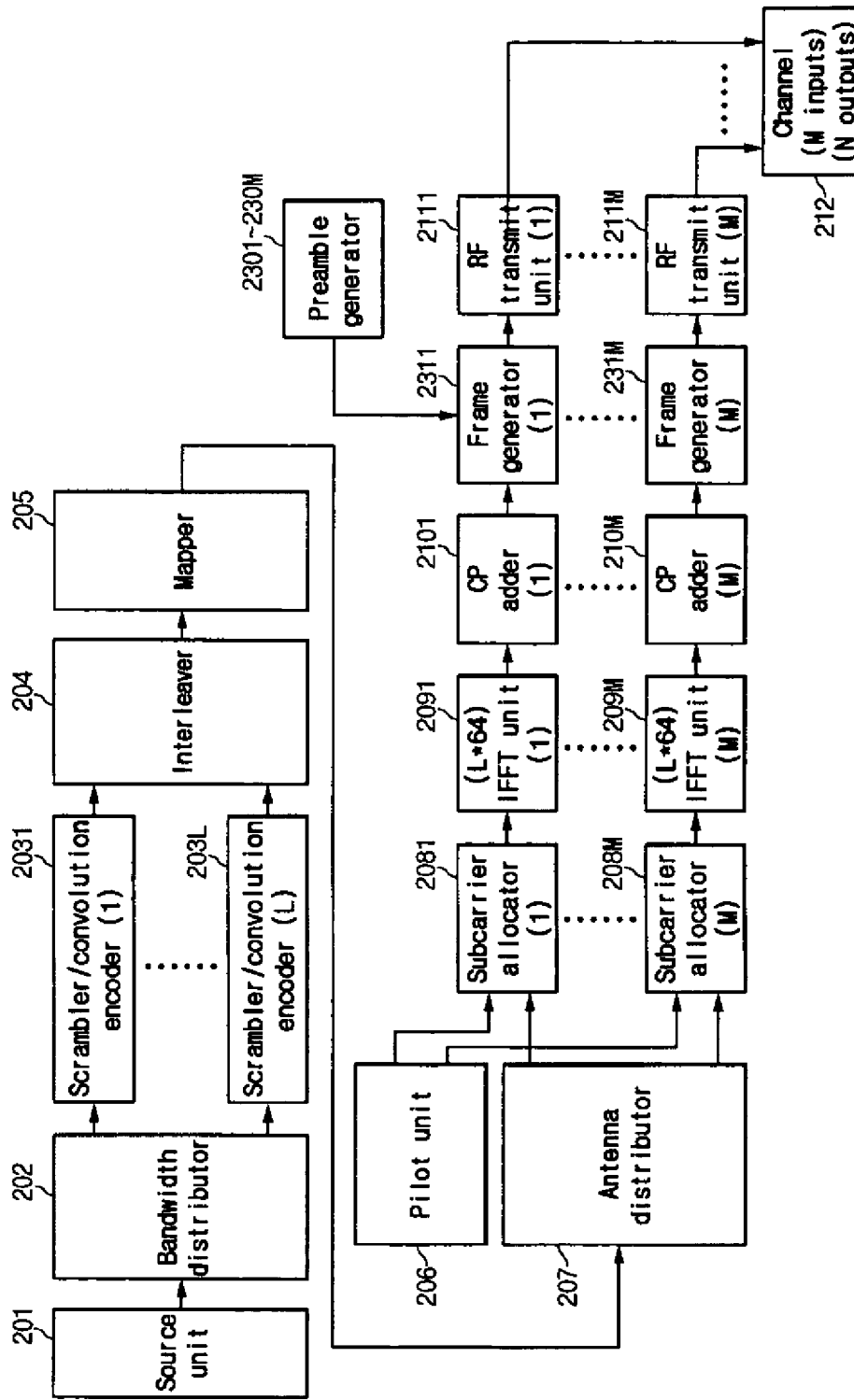
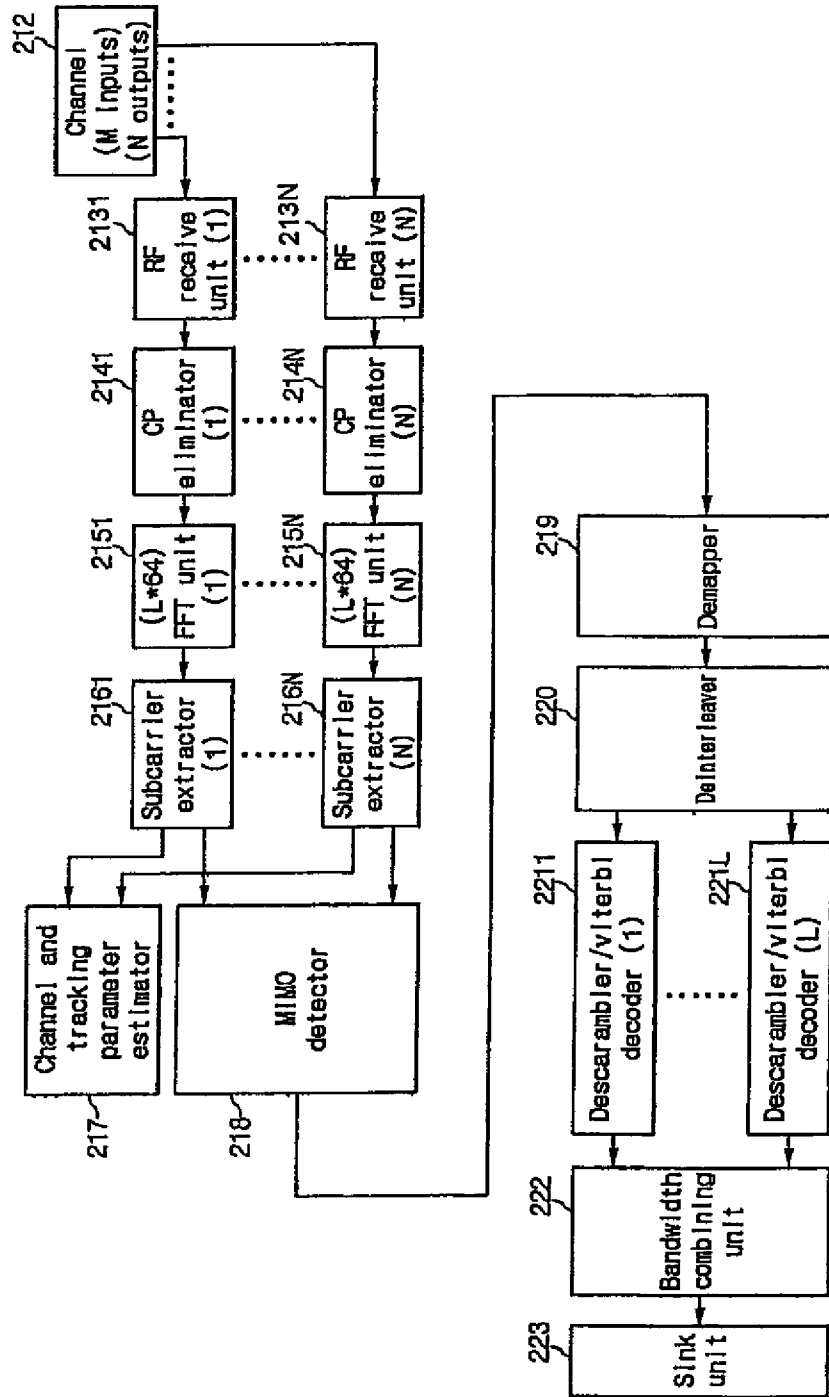

Fig. 3



Explore Litigation Insights

Docket Alarm provides insights to develop a more informed litigation strategy and the peace of mind of knowing you're on top of things.

Real-Time Litigation Alerts



Keep your litigation team up-to-date with **real-time alerts** and advanced team management tools built for the enterprise, all while greatly reducing PACER spend.

Our comprehensive service means we can handle Federal, State, and Administrative courts across the country.

Advanced Docket Research



With over 230 million records, Docket Alarm's cloud-native docket research platform finds what other services can't. Coverage includes Federal, State, plus PTAB, TTAB, ITC and NLRB decisions, all in one place.

Identify arguments that have been successful in the past with full text, pinpoint searching. Link to case law cited within any court document via Fastcase.

Analytics At Your Fingertips



Learn what happened the last time a particular judge, opposing counsel or company faced cases similar to yours.

Advanced out-of-the-box PTAB and TTAB analytics are always at your fingertips.

API

Docket Alarm offers a powerful API (application programming interface) to developers that want to integrate case filings into their apps.

LAW FIRMS

Build custom dashboards for your attorneys and clients with live data direct from the court.

Automate many repetitive legal tasks like conflict checks, document management, and marketing.

FINANCIAL INSTITUTIONS

Litigation and bankruptcy checks for companies and debtors.

E-DISCOVERY AND LEGAL VENDORS

Sync your system to PACER to automate legal marketing.