



US007315919B1

(12) **United States Patent**  
**O’Krafka et al.**

(10) **Patent No.:** **US 7,315,919 B1**  
(45) **Date of Patent:** **\*Jan. 1, 2008**

(54) **BANDWIDTH REDUCTION TECHNIQUE IN A SNOOPING-BASED CACHE-COHERENT CLUSTER OF MULTIPROCESSING NODES**

(75) Inventors: **Brian W. O’Krafka**, Austin, TX (US);  
**Michael J. Koster**, Fremont, CA (US)

(73) Assignee: **Sun Microsystems, Inc.**, Santa Clara, CA (US)

(\* ) Notice: Subject to any disclaimer, the term of this patent is extended or adjusted under 35 U.S.C. 154(b) by 490 days.

This patent is subject to a terminal disclaimer.

(21) Appl. No.: **10/868,053**

(22) Filed: **Jun. 15, 2004**

(51) **Int. Cl.**  
**G06F 12/00** (2006.01)

(52) **U.S. Cl.** ..... **711/141; 711/146; 711/147**

(58) **Field of Classification Search** ..... None  
See application file for complete search history.

(56) **References Cited**

**U.S. PATENT DOCUMENTS**

6,883,070 B2 4/2005 Martin et al.

6,981,097 B2 12/2005 Martin et al.  
2002/0133674 A1 9/2002 Martin et al.  
2005/0144395 A1 6/2005 Martin et al.  
2005/0160430 A1 7/2005 Steely et al.  
2005/0198187 A1 9/2005 Tierney et al.  
2005/0240735 A1 10/2005 Shen et al.

*Primary Examiner*—Hyung Sough

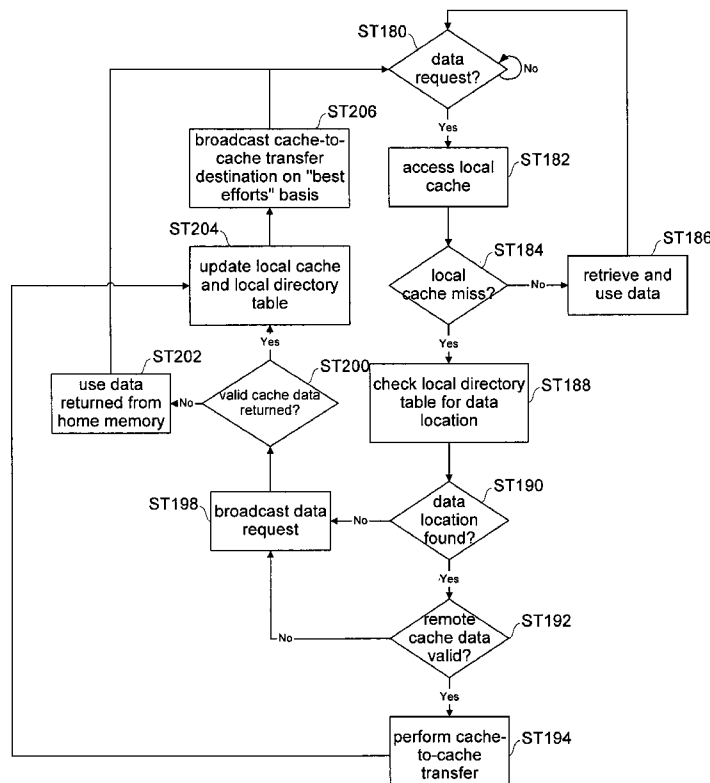
*Assistant Examiner*—Mardochee Chery

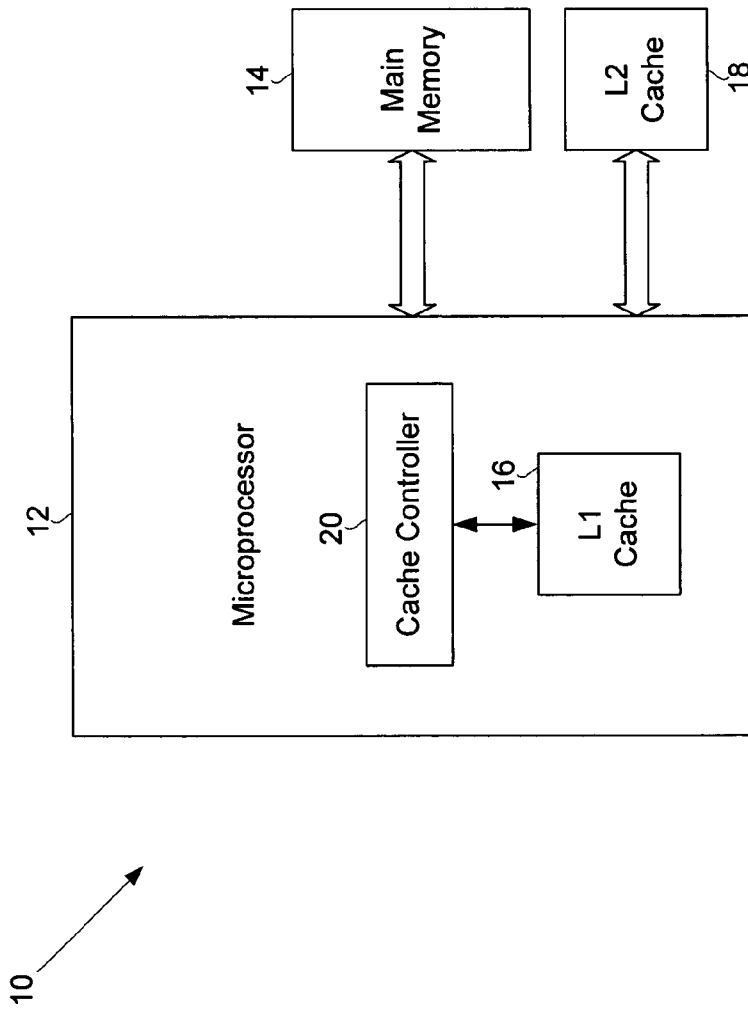
(74) *Attorney, Agent, or Firm*—Osha • Liang LLP

(57) **ABSTRACT**

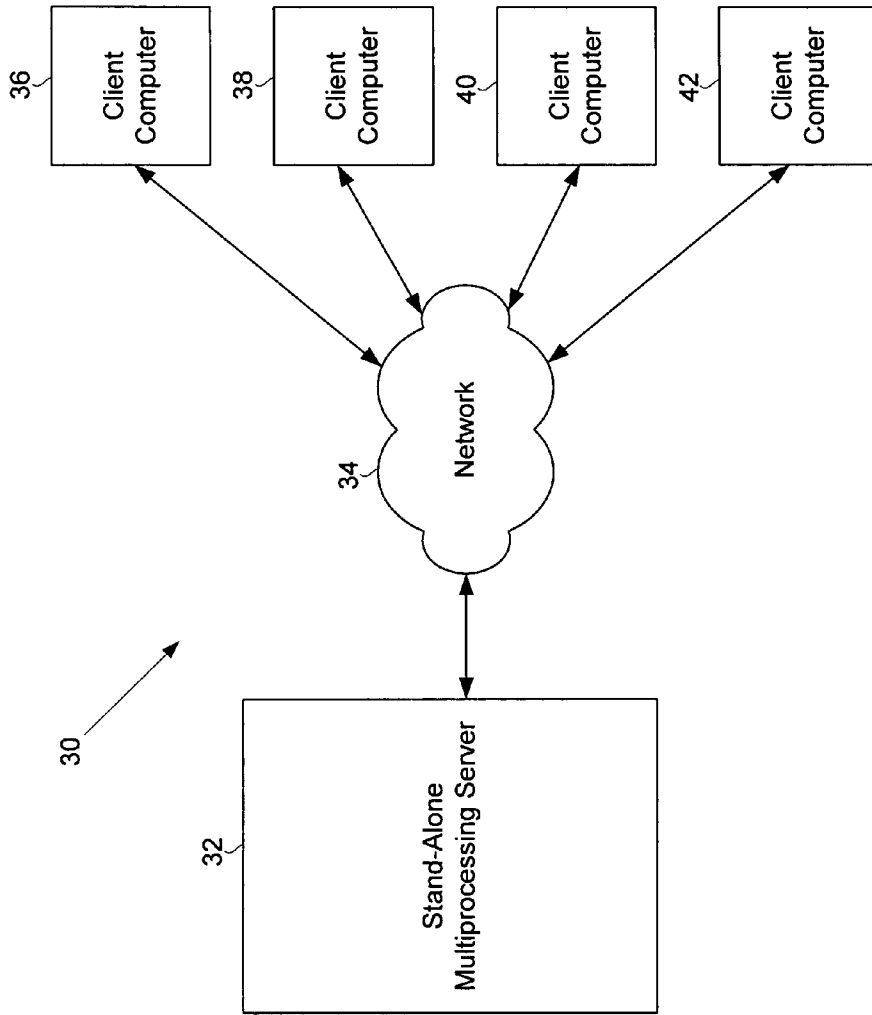
A cluster of multiprocessing nodes uses snooping-based cache-coherence to maintain consistency among the cache memories of the multiprocessing nodes. One or more of the multiprocessing nodes each maintain a directory table that includes a list of addresses of data last transferred by cache-to-cache transfer transactions. Thus, upon a local cache miss for requested data, a multiprocessing node searches its directory table for an address of the requested data, and if the address is found in the directory table, the multiprocessing node obtains a copy of the requested data from the last destination of the requested data as indicated in the directory table. Thereafter, a message indicating the completion of a cache-to-cache transfer is broadcast to other connected multiprocessing nodes on a “best efforts” basis in which messages are relayed from multiprocessing node to multiprocessing node using low priority status and/or otherwise unused cycles.

**15 Claims, 10 Drawing Sheets**

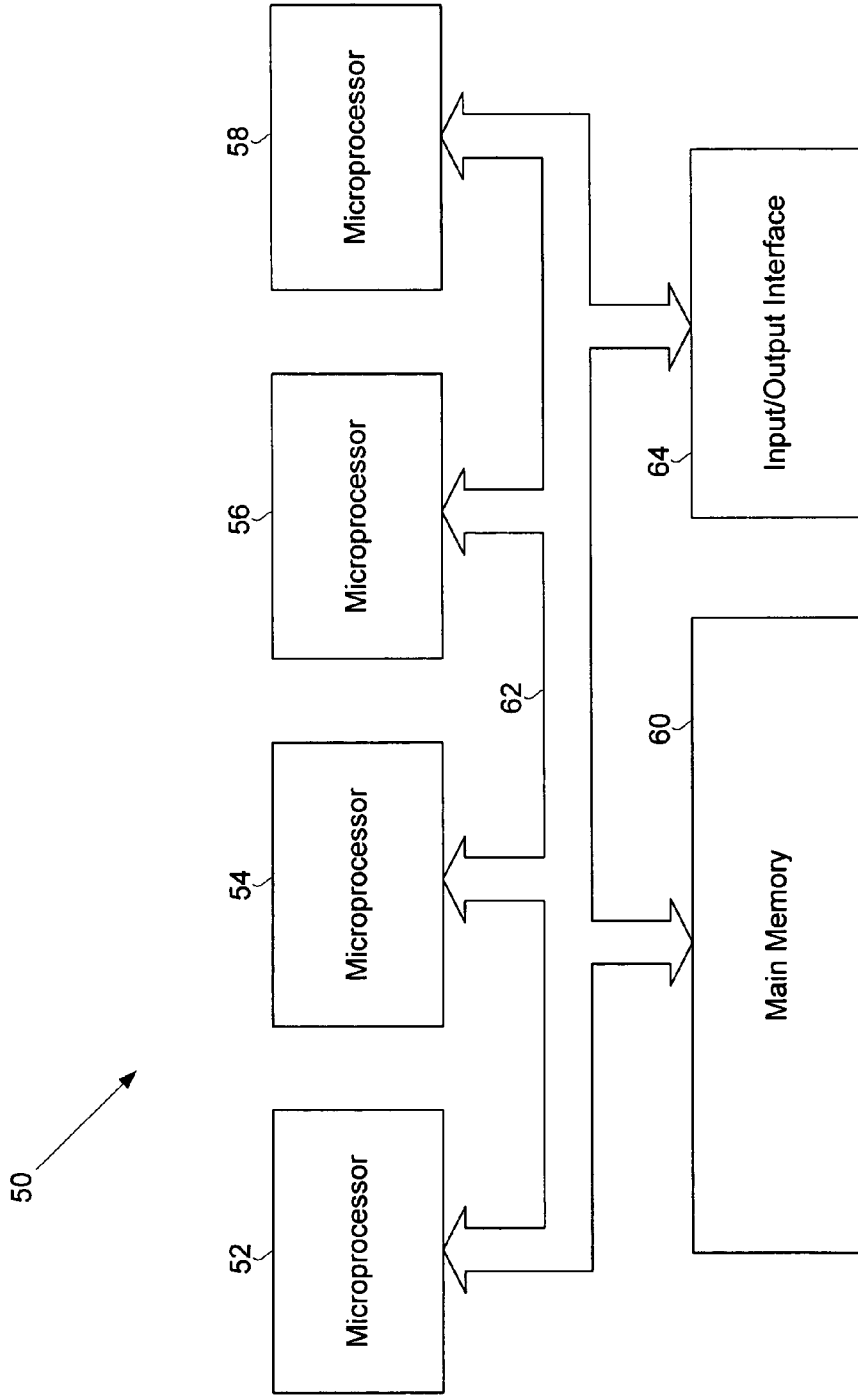




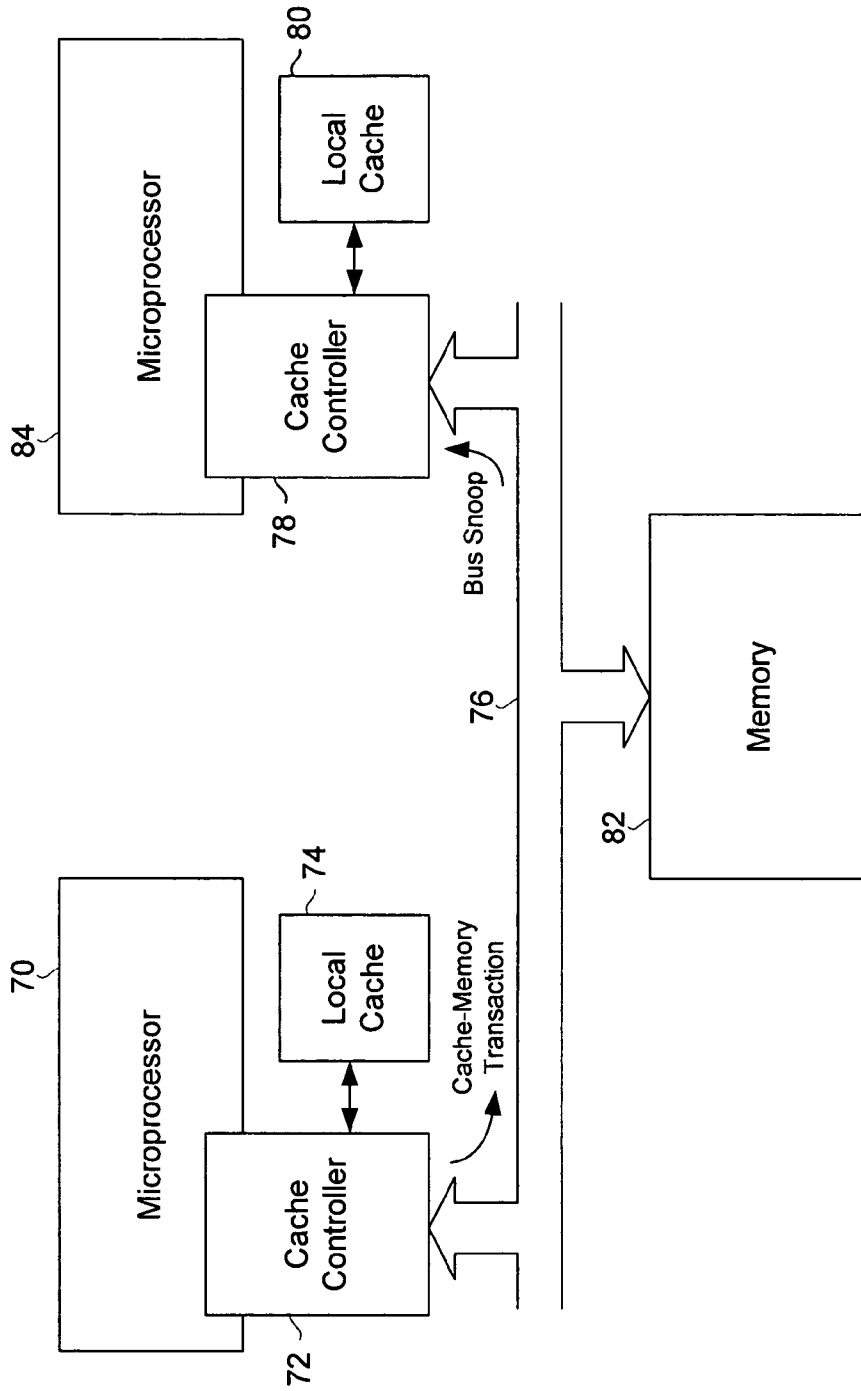
**FIG. 1**  
*(Prior Art)*



**FIG. 2**  
*(Prior Art)*



**FIG. 3**  
**(Prior Art)**



**FIG. 4**

# Explore Litigation Insights

Docket Alarm provides insights to develop a more informed litigation strategy and the peace of mind of knowing you're on top of things.

## Real-Time Litigation Alerts



Keep your litigation team up-to-date with **real-time alerts** and advanced team management tools built for the enterprise, all while greatly reducing PACER spend.

Our comprehensive service means we can handle Federal, State, and Administrative courts across the country.

## Advanced Docket Research



With over 230 million records, Docket Alarm's cloud-native docket research platform finds what other services can't. Coverage includes Federal, State, plus PTAB, TTAB, ITC and NLRB decisions, all in one place.

Identify arguments that have been successful in the past with full text, pinpoint searching. Link to case law cited within any court document via Fastcase.

## Analytics At Your Fingertips



Learn what happened the last time a particular judge, opposing counsel or company faced cases similar to yours.

Advanced out-of-the-box PTAB and TTAB analytics are always at your fingertips.

## API

Docket Alarm offers a powerful API (application programming interface) to developers that want to integrate case filings into their apps.

## LAW FIRMS

Build custom dashboards for your attorneys and clients with live data direct from the court.

Automate many repetitive legal tasks like conflict checks, document management, and marketing.

## FINANCIAL INSTITUTIONS

Litigation and bankruptcy checks for companies and debtors.

## E-DISCOVERY AND LEGAL VENDORS

Sync your system to PACER to automate legal marketing.