



US005941972A

United States Patent [19]

[11] Patent Number: **5,941,972**

Hoese et al.

[45] Date of Patent: **Aug. 24, 1999**

[54] **STORAGE ROUTER AND METHOD FOR PROVIDING VIRTUAL LOCAL STORAGE**

Primary Examiner—Christopher B. Shin
Attorney, Agent, or Firm—Gray Cary Ware & Freidenrich, LLP

[75] Inventors: **Geoffrey B. Hoese**, Austin; **Jeffrey T. Russell**, Cibolo, both of Tex.

[57] **ABSTRACT**

[73] Assignee: **Crossroads Systems, Inc.**, Austin, Tex.

A storage router (56) and storage network (50) provide virtual local storage on remote SCSI storage devices (60, 62, 64) to Fiber Channel devices. A plurality of Fiber Channel devices, such as workstations (58), are connected to a Fiber Channel transport medium (52), and a plurality of SCSI storage devices (60, 62, 64) are connected to a SCSI bus transport medium (54). The storage router (56) interfaces between the Fiber Channel transport medium (52) and the SCSI bus transport medium (54). The storage router (56) maps between the workstations (58) and the SCSI storage devices (60, 62, 64) and implements access controls for storage space on the SCSI storage devices (60, 62, 64). The storage router (56) then allows access from the workstations (58) to the SCSI storage devices (60, 62, 64) using native low level, block protocol in accordance with the mapping and the access controls.

[21] Appl. No.: **09/001,799**

[22] Filed: **Dec. 31, 1997**

[51] Int. Cl.⁶ **G06F 13/00**

[52] U.S. Cl. **710/129; 710/128; 710/2**

[58] Field of Search **710/1-2, 100-101, 710/126-131**

[56] **References Cited**

U.S. PATENT DOCUMENTS

5,748,924	5/1998	Llorens et al.	395/309
5,768,623	6/1998	Judd et al.	395/857
5,809,328	9/1998	Nogales et al.	395/825
5,812,754	9/1998	Lui et al.	395/182.04
5,835,496	1/1998	Yeung et al.	370/514
5,848,251	12/1998	Lomelino et al.	395/309

14 Claims, 2 Drawing Sheets

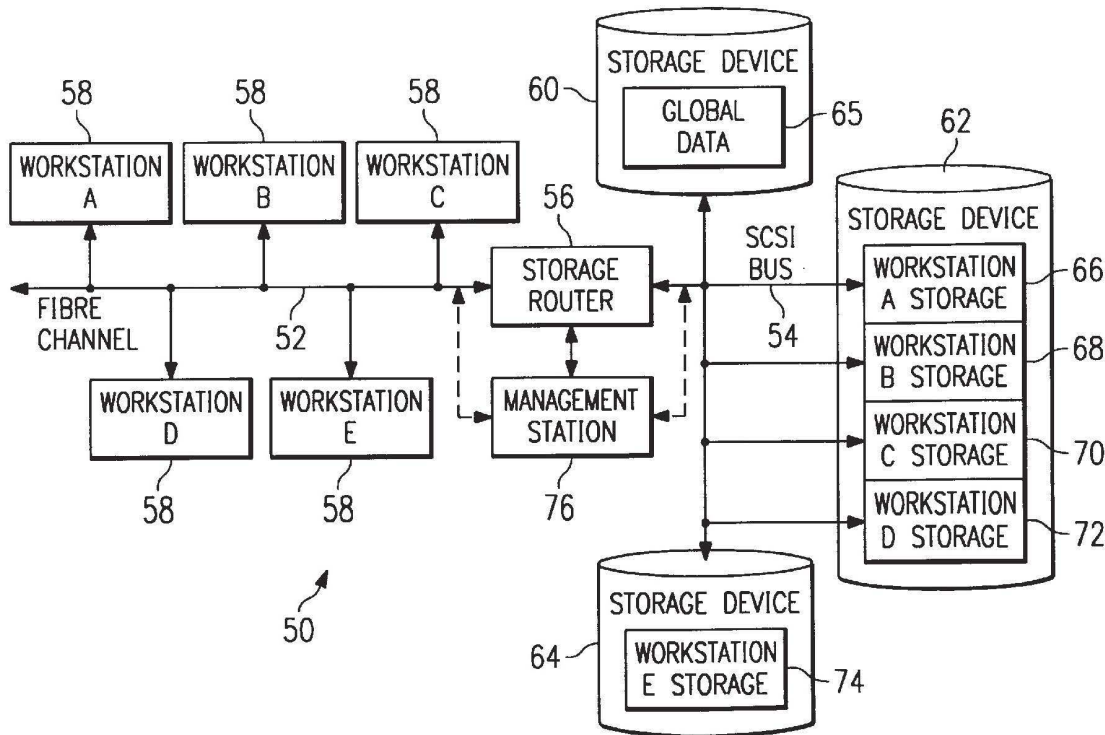

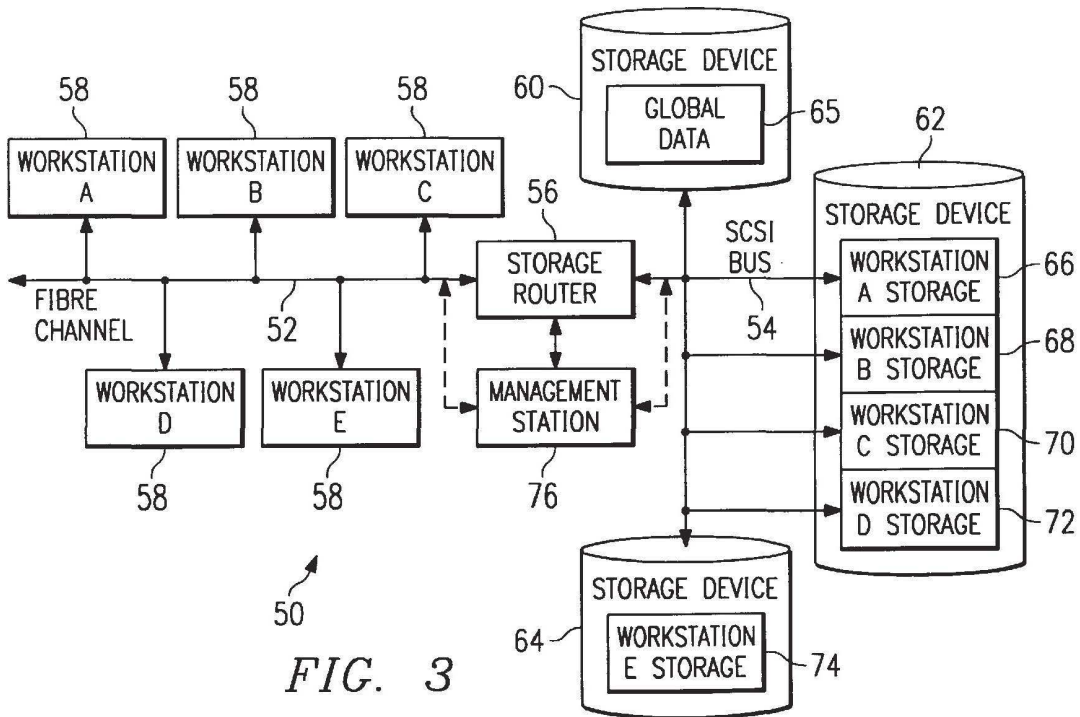
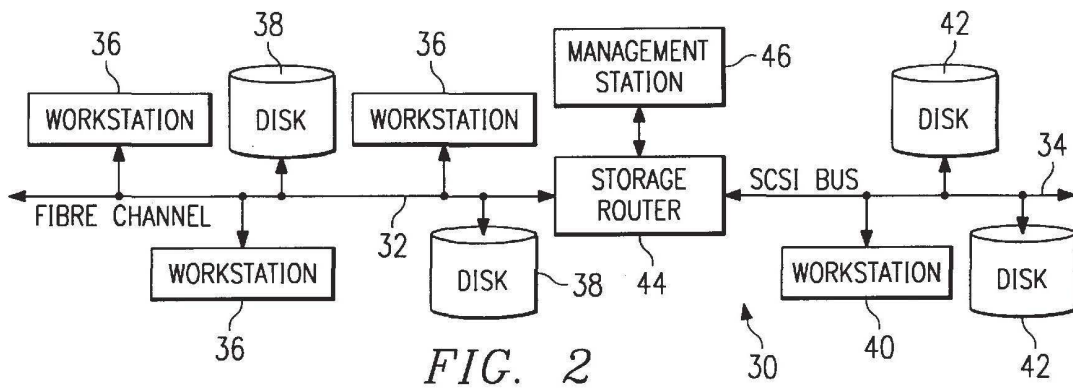
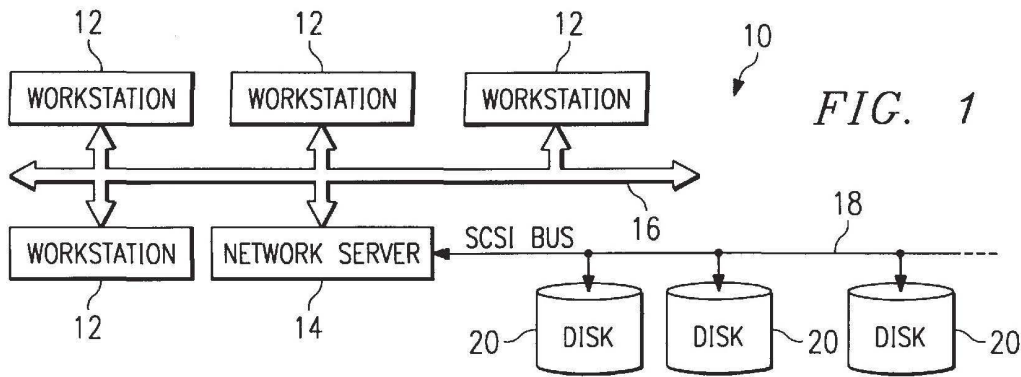

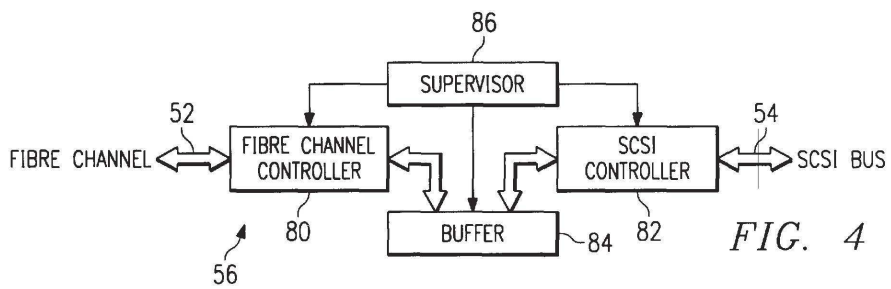

FIG. 4

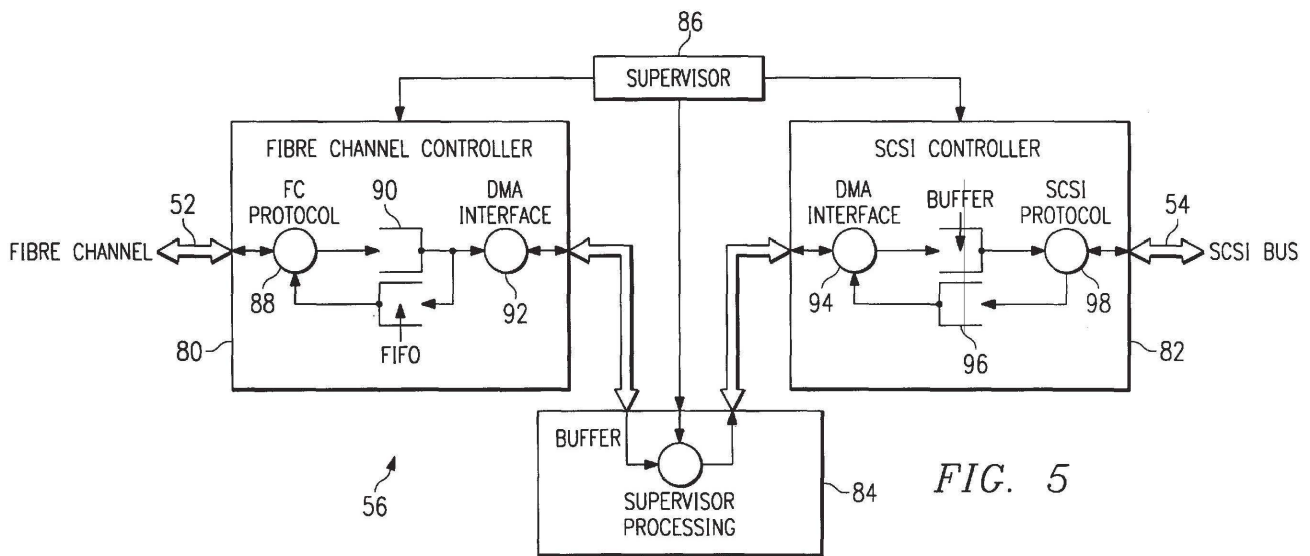

FIG. 5

STORAGE ROUTER AND METHOD FOR PROVIDING VIRTUAL LOCAL STORAGE

TECHNICAL FIELD OF THE INVENTION

This invention relates in general to network storage devices, and more particularly to a storage router and method for providing virtual local storage on remote SCSI storage devices to Fibre Channel devices.

BACKGROUND OF THE INVENTION

Typical storage transport mediums provide for a relatively small number of devices to be attached over relatively short distances. One such transport medium is a Small Computer System Interface (SCSI) protocol, the structure and operation of which is generally well known as is described, for example, in the SCSI-1, SCSI-2 and SCSI-3 specifications. High speed serial interconnects provide enhanced capability to attach a large number of high speed devices to a common storage transport medium over large distances. One such serial interconnect is Fibre Channel, the structure and operation of which is described, for example, in *Fibre Channel Physical and Signaling Interface (FC-PH)*, ANSI X3.230 *Fibre Channel Arbitrated Loop (FC-AL)*, and ANSI X3.272 *Fibre Channel Private Loop Direct Attach (FC-PLDA)*.

Conventional computing devices, such as computer workstations, generally access storage locally or through network interconnects. Local storage typically consists of a disk drive, tape drive, CD-ROM drive or other storage device contained within, or locally connected to the workstation. The workstation provides a file system structure, that includes security controls, with access to the local storage device through native low level, block protocols. These protocols map directly to the mechanisms used by the storage device and consist of data requests without security controls. Network interconnects typically provide access for a large number of computing devices to data storage on a remote network server. The remote network server provides file system structure, access control, and other miscellaneous capabilities that include the network interface. Access to data through the network server is through network protocols that the server must translate into low level requests to the storage device. A workstation with access to the server storage must translate its file system protocols into network protocols that are used to communicate with the server. Consequently, from the perspective of a workstation, or other computing device, seeking to access such server data, the access is much slower than access to data on a local storage device.

SUMMARY OF THE INVENTION

In accordance with the present invention, a storage router and method for providing virtual local storage on remote SCSI storage devices to Fibre Channel devices are disclosed that provide advantages over conventional network storage devices and methods.

According to one aspect of the present invention, a storage router and storage network provide virtual local storage on remote SCSI storage devices to Fibre Channel devices. A plurality of Fibre Channel devices, such as workstations, are connected to a Fibre Channel transport medium, and a plurality of SCSI storage devices are connected to a SCSI bus transport medium. The storage router interfaces between the Fibre Channel transport medium and the SCSI bus transport medium. The storage router maps between the workstations and the SCSI storage devices and

implements access controls for storage space on the SCSI storage devices. The storage router then allows access from the workstations to the SCSI storage devices using native low level, block protocol in accordance with the mapping and the access controls.

According to another aspect of the present invention, virtual local storage on remote SCSI storage devices is provided to Fibre Channel devices. A Fibre Channel transport medium and a SCSI bus transport medium are interfaced with. A configuration is maintained for SCSI storage devices connected to the SCSI bus transport medium. The configuration maps between Fibre Channel devices and the SCSI storage devices and implements access controls for storage space on the SCSI storage devices. Access is then allowed from Fibre Channel initiator devices to SCSI storage devices using native low level, block protocol in accordance with the configuration.

A technical advantage of the present invention is the ability to centralize local storage for networked workstations without any cost of speed or overhead. Each workstation access its virtual local storage as if it work locally connected. Further, the centralized storage devices can be located in a significantly remote position even in excess of ten kilometers as defined by Fibre Channel standards.

Another technical advantage of the present invention is the ability to centrally control and administer storage space for connected users without limiting the speed with which the users can access local data. In addition, global access to data, backups, virus scanning and redundancy can be more easily accomplished by centrally located storage devices.

A further technical advantage of the present invention is providing support for SCSI storage devices as local storage for Fibre Channel hosts. In addition, the present invention helps to provide extended capabilities for Fibre Channel and for management of storage subsystems.

BRIEF DESCRIPTION OF THE DRAWINGS

A more complete understanding of the present invention and the advantages thereof may be acquired by referring to the following description taken in conjunction with the accompanying drawings, in which like reference numbers indicate like features, and wherein:

FIG. 1 is a block diagram of a conventional network that provides storage through a network server;

FIG. 2 is a block diagram of one embodiment of a storage network with a storage router that provides global access and routing;

FIG. 3 is a block diagram of one embodiment of a storage network with a storage router that provides virtual local storage;

FIG. 4 is a block diagram of one embodiment of the storage router of FIG. 3; and

FIG. 5 is a block diagram of one embodiment of data flow within the storage router of FIG. 4.

DETAILED DESCRIPTION OF THE INVENTION

FIG. 1 is a block diagram of a conventional network, indicated generally at **10**, that provides access to storage through a network server. As shown, network **10** includes a plurality of workstations **12** interconnected with a network server **14** via a network transport medium **16**. Each workstation **12** can generally comprise a processor, memory, input/output devices, storage devices and a network adapter as well as other common computer components. Network

3

server **14** uses a SCSI bus **18** as a storage transport medium to interconnect with a plurality of storage devices **20** (tape drives, disk drives, etc.). In the embodiment of FIG. **1**, network transport medium **16** is a network connection and storage devices **20** comprise hard disk drives, although there are numerous alternate transport mediums and storage devices.

In network **10**, each workstation **12** has access to its local storage device as well as network access to data on storage devices **20**. The access to a local storage device is typically through native low level, block protocols. On the other hand, access by a workstation **12** to storage devices **20** requires the participation of network server **14** which implements a file system and transfers data to workstations **12** only through high level file system protocols. Only network server **14** communicates with storage devices **20** via native low level, block protocols. Consequently, the network access by workstations **12** through network server **14** is slow with respect to their access to local storage. In network **10**, it can also be a logistical problem to centrally manage and administer local data distributed across an organization, including accomplishing tasks such as backups, virus scanning and redundancy.

FIG. **2** is a block diagram of one embodiment of a storage network, indicated generally at **30**, with a storage router that provides global access and routing. This environment is significantly different from that of FIG. **1** in that there is no network server involved. In FIG. **2**, a Fibre Channel high speed serial transport **32** interconnects a plurality of workstations **36** and storage devices **38**. A SCSI bus storage transport medium interconnects workstations **40** and storage devices **42**. A storage router **44** then serves to interconnect these mediums and provide devices on either medium global, transparent access to devices on the other medium. Storage router **44** routes requests from initiator devices on one medium to target devices on the other medium and routes data between the target and the initiator. Storage router **44** can allow initiators and targets to be on either side. In this manner, storage router **44** enhances the functionality of Fibre Channel **32** by providing access, for example, to legacy SCSI storage devices on SCSI bus **34**. In the embodiment of FIG. **2**, the operation of storage router **44** can be managed by a management station **46** connected to the storage router via a direct serial connection.

In storage network **30**, any workstation **36** or workstation **40** can access any storage device **38** or storage device **42** through native low level, block protocols, and vice versa. This functionality is enabled by storage router **44** which routes requests and data as a generic transport between Fibre Channel **32** and SCSI bus **34**. Storage router **44** uses tables to map devices from one medium to the other and distributes requests and data across Fibre Channel **32** and SCSI bus **34** without any security access controls. Although this extension of the high speed serial interconnect provided by Fibre Channel **32** is beneficial, it is desirable to provide security controls in addition to extended access to storage devices through a native low level, block protocol.

FIG. **3** is a block diagram of one embodiment of a storage network, indicated generally at **50**, with a storage router that provides virtual local storage. Similar to that of FIG. **2**, storage network **50** includes a Fibre Channel high speed serial interconnect **52** and a SCSI bus **54** bridged by a storage router **56**. Storage router **56** of FIG. **3** provides for a large number of workstations **58** to be interconnected on a common storage transport and to access common storage devices **60**, **62** and **64** through native low level, block protocols.

4

According to the present invention, storage router **56** has enhanced functionality to implement security controls and routing such that each workstation **58** can have access to a specific subset of the overall data stored in storage devices **60**, **62** and **64**. This specific subset of data has the appearance and characteristics of local storage and is referred to herein as virtual local storage. Storage router **56** allows the configuration and modification of the storage allocated to each attached workstation **58** through the use of mapping tables or other mapping techniques.

As shown in FIG. **3**, for example, storage device **60** can be configured to provide global data **65** which can be accessed by all workstations **58**. Storage device **62** can be configured to provide partitioned subsets **66**, **68**, **70** and **72**, where each partition is allocated to one of the workstations **58** (workstations A, B, C and D). These subsets **66**, **68**, **70** and **72** can only be accessed by the associated workstation **58** and appear to the associated workstation **58** as local storage accessed using native low level, block protocols. Similarly, storage device **64** can be allocated as storage for the remaining workstation **58** (workstation E).

Storage router **56** combines access control with routing such that each workstation **58** has controlled access to only the specified partition of storage device **62** which forms virtual local storage for the workstation **58**. This access control allows security control for the specified data partitions. Storage router **56** allows this allocation of storage devices **60**, **62** and **64** to be managed by a management station **76**. Management station **76** can connect directly to storage router **56** via a direct connection or, alternately, can interface with storage router **56** through either Fibre Channel **52** or SCSI bus **54**. In the latter case, management station **76** can be a workstation or other computing device with special rights such that storage router **56** allows access to mapping tables and shows storage devices **60**, **62** and **64** as they exist physically rather than as they have been allocated.

The environment of FIG. **3** extends the concept of a single workstation having locally connected storage devices to a storage network **50** in which workstations **58** are provided virtual local storage in a manner transparent to workstations **58**. Storage router **56** provides centralized control of what each workstation **58** sees as its local drive, as well as what data it sees as global data accessible by other workstations **58**. Consequently, the storage space considered by the workstation **58** to be its local storage is actually a partition (i.e., logical storage definition) of a physically remote storage device **60**, **62** or **64** connected through storage router **56**. This means that similar requests from workstations **58** for access to their local storage devices produce different accesses to the storage space on storage devices **60**, **62** and **64**. Further, no access from a workstation **58** is allowed to the virtual local storage of another workstation **58**.

The collective storage provided by storage devices **60**, **62** and **64** can have blocks allocated by programming means within storage router **56**. To accomplish this function, storage router **56** can include routing tables and security controls that define storage allocation for each workstation **58**. The advantages provided by implementing virtual local storage in centralized storage devices include the ability to do collective backups and other collective administrative functions more easily. This is accomplished without limiting the performance of workstations **58** because storage access involves native low level, block protocols and does not involve the overhead of high level protocols and file systems required by network servers.

FIG. **4** is a block diagram of one embodiment of storage router **56** of FIG. **3**. Storage router **56** can comprise a Fibre

Explore Litigation Insights

Docket Alarm provides insights to develop a more informed litigation strategy and the peace of mind of knowing you're on top of things.

Real-Time Litigation Alerts



Keep your litigation team up-to-date with **real-time alerts** and advanced team management tools built for the enterprise, all while greatly reducing PACER spend.

Our comprehensive service means we can handle Federal, State, and Administrative courts across the country.

Advanced Docket Research



With over 230 million records, Docket Alarm's cloud-native docket research platform finds what other services can't. Coverage includes Federal, State, plus PTAB, TTAB, ITC and NLRB decisions, all in one place.

Identify arguments that have been successful in the past with full text, pinpoint searching. Link to case law cited within any court document via Fastcase.

Analytics At Your Fingertips



Learn what happened the last time a particular judge, opposing counsel or company faced cases similar to yours.

Advanced out-of-the-box PTAB and TTAB analytics are always at your fingertips.

API

Docket Alarm offers a powerful API (application programming interface) to developers that want to integrate case filings into their apps.

LAW FIRMS

Build custom dashboards for your attorneys and clients with live data direct from the court.

Automate many repetitive legal tasks like conflict checks, document management, and marketing.

FINANCIAL INSTITUTIONS

Litigation and bankruptcy checks for companies and debtors.

E-DISCOVERY AND LEGAL VENDORS

Sync your system to PACER to automate legal marketing.