

US005790532A

United States Patent [19]

[11] Patent Number: **5,790,532**

Sharma et al.

[45] Date of Patent: ***Aug. 4, 1998**

[54] VOICE OVER VIDEO COMMUNICATION SYSTEM

[75] Inventors: **Raghu Sharma**, North Oaks; **Jeffrey P. Davis**, Ham Lake; **Timothy D. Gunn**, Mounds View; **Ping Li**, New Brighton, all of Minn.; **Sidhartha Maitra**, Saratoga, Calif.; **Ashish Thanawala**, Saratoga, Calif.; **Steve Young**, Saratoga, Calif.

[73] Assignee: **Multi-Tech Systems, Inc.**, Mounds View, Minn.

[*] Notice: The term of this patent shall not extend beyond the expiration date of Pat. No. 5,452,289.

[21] Appl. No.: **527,952**

[22] Filed: **Sep. 14, 1995**

Related U.S. Application Data

[62] Division of Ser. No. 2,467, Jan. 8, 1993, Pat. No. 5,452,289.

[51] Int. Cl.⁶ **H04J 3/16**

[52] U.S. Cl. **370/286; 370/435; 370/468**

[58] Field of Search 370/276, 286, 370/288, 289, 290, 465, 468, 470, 472, 477, 535; 395/2.28, 2.3, 2.31; 375/219, 220, 222, 245, 246, 249, 250, 240; 379/67, 88, 89, 207, 235, 90, 93, 96-98, 110, 201, 410, 411; 348/13-15, 473

[56] References Cited

U.S. PATENT DOCUMENTS

Re. 34,034 8/1992 O'Sullivan 379/59
3,304,372 2/1967 Filipowsky et al. 179/2

(List continued on next page.)

FOREIGN PATENT DOCUMENTS

0 429 054 A3 5/1991 European Pat. Off. .
0 443 548 A3 8/1991 European Pat. Off. .

(List continued on next page.)

OTHER PUBLICATIONS

"Video Calls Use Basic Phone Lines". Mitch Radcliffe, *MacWeek*, (Aug. 3, 1992).

(List continued on next page.)

Primary Examiner—Chau Nguyen
Attorney, Agent, or Firm—Schwegman, Lundberg, Woessner & Kluth, P.A.

[57] ABSTRACT

A personal communications system is described which includes components of software and hardware operating in conjunction with a personal computer. The user interface control software operates on a personal computer, preferably within the Microsoft Windows® environment. The software control system communicates with hardware components linked to the software through the personal computer serial communications port. The hardware components include telephone communication equipment, digital signal processors, and hardware to enable voice, fax and data communication with a remote site connected through a standard telephone line. The functions of the hardware components are controlled by control software operating within the hardware component and from the software components operating within the personal computer. The major functions of the system are a telephone function, a voice mail function, a fax manager function, a multi-media mail function, a show and tell function, a terminal function and an address book function. The telephone function allows the present system to operate, from the users perspective, as a conventional telephone using either hands-free, headset or handset operation. The telephone function is more sophisticated than a standard telephone in that the present system converts the voice into a digital signal which can be processed with echo cancellation, compressed, stored as digital data for later retrieval and transmitted as digital voice data concurrent with the transfer of digital information data.

15 Claims, 52 Drawing Sheets

Microfiche Appendix Included
(14 Microfiche, 1157 Pages)

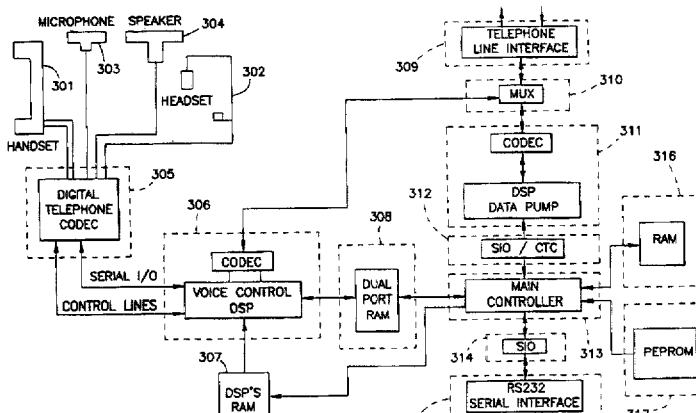

U.S. PATENT DOCUMENTS

3,789,165	1/1974	Campanella	179/170.2	4,972,462	11/1990	Shibata	379/89
3,904,830	9/1975	Every, Sr. et al.	179/18	4,972,483	11/1990	Carey	381/31
3,973,081	8/1976	Hutchins	179/1 SA	4,977,591	12/1990	Chen et al.	379/410
3,997,732	12/1976	Every, Sr. et al.	179/18	4,991,169	2/1991	Davis et al. .	
4,100,377	7/1978	Flanagan	179/15	4,995,059	2/1991	Ishikawa	375/27
4,107,471	8/1978	Reed	179/15	4,998,241	3/1991	Brox et al. .	
4,205,202	5/1980	Kahn .		5,001,710	3/1991	Gawrys et al. .	
4,284,850	8/1981	Clingenpeel .		5,001,745	3/1991	Pollock	379/96
4,354,273	10/1982	Araseki et al. .		5,005,183	4/1991	Carey et al. .	
4,377,860	3/1983	Godbole .		5,008,901	4/1991	Wallach et al. .	
4,403,322	9/1983	Kato et al. .		5,008,926	4/1991	Misholi	379/89
4,425,661	1/1984	Moses et al. .		5,014,232	5/1991	Andre	364/724.19
4,445,213	4/1984	Baugh et al. .		5,020,058	5/1991	Holden et al. .	
4,476,559	10/1984	Brolin et al. .		5,025,443	6/1991	Gupta .	
4,479,195	10/1984	Herr et al. .		5,036,513	7/1991	Greenblatt .	
4,479,213	10/1984	Galand et al. .		5,044,010	8/1991	Frenkiel et al.	379/61
4,495,620	1/1985	Steele et al. .		5,046,188	9/1991	Molnar	379/94
4,500,987	2/1985	Hasegawa .		5,051,720	9/1991	Kittirutsunetorn	340/310
4,524,244	6/1985	Faggin et al.	179/2	5,062,133	10/1991	Melrose	379/94
4,534,024	8/1985	Maxemchuk et al. .		5,065,395	11/1991	Shenoi et al. .	
4,546,212	10/1985	Crowder, Sr.	179/2	5,065,425	11/1991	Lecomte et al.	379/93
4,578,537	3/1986	Faggin et al.	179/2	5,081,647	1/1992	Bremer .	
4,587,651	5/1986	Nelson et al. .		5,083,310	1/1992	Drory	381/30
4,593,389	6/1986	Wurzburg et al. .		5,086,471	2/1992	Tanaka et al.	381/36
4,598,397	7/1986	Nelson et al.	370/110.1	5,099,472	3/1992	Townsend et al. .	
4,609,788	9/1986	Miller et al.	179/170.6	5,107,519	4/1992	Ishikawa .	
4,610,022	9/1986	Kitayama et al.	381/36	5,115,429	5/1992	Hluchyj et al. .	
4,622,680	11/1986	Zinser .		5,121,385	6/1992	Tominaga et al. .	
4,629,829	12/1986	Puhl et al.	379/58	5,127,001	6/1992	Steagall et al. .	
4,652,703	3/1987	Lu et al.	379/339	5,127,041	6/1992	O'Sullivan	379/59
4,660,218	4/1987	Hashimoto	379/93	5,132,966	7/1992	Hayano et al. .	
4,670,874	6/1987	Sato et al. .		5,136,586	8/1992	Greenblatt .	
4,697,281	9/1987	O'Sullivan	379/59	5,138,662	8/1992	Amano et al.	381/36
4,700,341	10/1987	Huang .		5,146,470	9/1992	Fujii et al. .	
4,707,831	11/1987	Weir et al. .		5,150,410	9/1992	Bertrand	380/28
4,718,082	1/1988	Parker et al.	379/98	5,151,937	9/1992	Chujo et al.	379/410
4,740,963	4/1988	Eckley .		5,153,897	10/1992	Sumiyoshi et al. .	
4,750,169	6/1988	Carse et al. .		5,162,812	11/1992	Aman et al. .	
4,751,510	6/1988	De Saint Michel et al.	340/825.07	5,164,982	11/1992	Davis	379/96
4,751,736	6/1988	Gupta et al.	381/31	5,177,734	1/1993	Cummiskey et al. .	
4,757,527	7/1988	Beniston et al.	379/410	5,182,762	1/1993	Shirai et al. .	
4,764,955	8/1988	Galand et al.	379/411	5,187,591	2/1993	Guy et al.	358/425
4,794,595	12/1988	Ohyama .		5,187,692	2/1993	Haneda et al.	367/135
4,807,250	2/1989	Tanaka	375/28	5,193,110	3/1993	Jones et al.	379/94
4,809,271	2/1989	Kondo et al. .		5,195,130	3/1993	Weiss et al.	379/98
4,813,040	3/1989	Futato .		5,208,812	5/1993	Dudek et al. .	
4,827,085	5/1989	Yaniv et al.	178/18	5,208,850	5/1993	Kino	379/88
4,835,765	5/1989	Bergmans et al. .		5,214,656	5/1993	Chung et al.	371/43
4,839,802	6/1989	Wonak et al.	364/200	5,228,026	7/1993	Albrow et al. .	
4,845,746	7/1989	Li	379/411	5,233,660	8/1993	Chen	381/38
4,847,900	7/1989	Wakim	379/424	5,235,595	8/1993	O'Dowd .	
4,862,449	8/1989	Hoefkens et al. .		5,249,218	9/1993	Sainton	379/59
4,864,559	9/1989	Perlman .		5,258,983	11/1993	Lane et al. .	
4,866,732	9/1989	Carey et al.	375/1	5,261,027	11/1993	Taniguchi et al.	395/2
4,873,715	10/1989	Shibata	379/93	5,263,019	11/1993	Chu .	
4,887,265	12/1989	Felix .		5,272,695	12/1993	Makino et al. .	
4,890,282	12/1989	Lambert et al. .		5,276,703	1/1994	Budin et al.	375/1
4,890,316	12/1989	Walsh et al.	379/98	5,278,900	1/1994	Van Gerwen et al.	379/410
4,901,333	2/1990	Hodgkiss	375/98	5,282,197	1/1994	Kreitzer .	
4,905,282	2/1990	McGlynn et al.	380/48	5,283,638	2/1994	Engberg et al.	348/14
4,912,756	3/1990	Hop .		5,283,819	2/1994	Glick et al.	379/90
4,912,758	3/1990	Arbel	379/388	5,289,539	2/1994	Maryama	379/410
4,914,650	4/1990	Sriram .		5,295,136	3/1994	Ashley et al. .	
4,926,448	5/1990	Kraul et al.	375/121	5,297,203	3/1994	Rose et al.	380/9
4,932,048	6/1990	Kenmochi et al.	379/67	5,305,312	4/1994	Fornek et al. .	
4,935,954	6/1990	Thompson et al.	379/89	5,307,413	4/1994	Denzer	380/49
4,942,569	7/1990	Maeno .		5,309,562	5/1994	Li	395/200
4,953,210	8/1990	McGlynn et al.	380/48	5,313,498	5/1994	Sano .	
4,965,789	10/1990	Bottau et al. .		5,317,064	5/1994	Osterweil .	
				5,319,682	6/1994	Clark .	
				5,327,520	7/1994	Chen	395/2.28

5,341,374	8/1994	Lewen et al. .	
5,343,473	8/1994	Cidon et al. .	
5,343,521	8/1994	Jullien et al.	379/410
5,355,365	10/1994	Bhat et al.	370/85.13
5,365,577	11/1994	Davis et al.	379/96
5,371,853	12/1994	Kao et al. .	
5,379,340	1/1995	Overend et al.	379/93
5,381,412	1/1995	Otani .	
5,384,780	1/1995	Lomp et al. .	
5,390,239	2/1995	Morris et al.	379/93
5,390,250	2/1995	Janse et al.	379/410
5,402,474	3/1995	Miller et al.	379/93
5,406,557	4/1995	Baudoin et al.	370/61
5,406,560	4/1995	Kondo et al. .	
5,414,796	5/1995	Jacobs et al. .	
5,416,776	5/1995	Panzarella et al. .	
5,438,614	8/1995	Rozman et al.	379/93
5,440,547	8/1995	Easki et al. .	
5,440,698	8/1995	Sindhu et al.	395/200.08
5,444,770	8/1995	Davis et al.	379/99
5,452,289	9/1995	Sharma et al.	370/286
5,463,616	10/1995	Kruse et al.	370/24
5,472,351	12/1995	Greco et al. .	
5,473,676	12/1995	Frick et al.	379/99
5,479,407	12/1995	Ko et al.	370/94.1
5,479,475	12/1995	Grob et al.	379/58
5,490,060	2/1996	Malec et al. .	
5,493,609	2/1996	Winseck, Jr. et al.	379/962

FOREIGN PATENT DOCUMENTS

488685A2	6/1992	European Pat. Off. .	
0 510 411 A2	10/1992	European Pat. Off.	H04M 3/42
0 526 104 A2	2/1993	European Pat. Off.	H04L 12/56
0 581 528 A1	2/1994	European Pat. Off.	G06F 1/00
0 582 537 A3	2/1994	European Pat. Off.	H04L 29/06
0 650 286 A2	4/1994	European Pat. Off.	H04M 11/06
0 614 305 A3	9/1994	European Pat. Off.	H04N 1/00
3504064	8/1986	Germany .	
3630469	3/1988	Germany .	
3409532	4/1989	Germany .	
63-054052	8/1988	Japan .	
193489	7/1990	Japan .	
257748	10/1990	Japan .	
3162052	7/1991	Japan	H04M 1/66
2210237	1/1989	United Kingdom .	
2 260 670	4/1993	United Kingdom	H04M 1/66
2 268 663	1/1994	United Kingdom	H04M 1/57
WO 91/07044	5/1991	WIPO .	
WO 92/06550	4/1992	WIPO .	
WO 92/20028	11/1992	WIPO .	
WO 93/11643	6/1993	WIPO	H04N 11/00
WO 93/22869	11/1993	WIPO .	
WO 94/26056	11/1994	WIPO .	

OTHER PUBLICATIONS

"Radish System Lets Phone Users Send Voice, Data Simultaneously", *PC Week*, 9, 19, pp. 53, (May 11, 1992).
 "Don't Just Tell Them, Show Them!", Glenn A. Pierce, Jr., *Automation*, (Aug. 1990).
 "Mitsubishi Still Color Picture TV Phone", *Techno Japan*, 23, 6, (Jun. 1990).
 "The Photophone", (Product Brochure) GTE (Feb. 15, 1990).
 "Wrist TVs Still Fiction, but Police Videophones Take Hold", Ray Smith, *TE&M*, (Dec. 15, 1987).
 "Audiographic Terminal", M. Laube, *Electrical Communication*, 60, 1, (1986).
 "Comparison of Coding Schemes for Telewriting Systems",

"Simultaneous Transmission of Voice and Handwriting Signals: Sketchphone System", Kishimoto et al., *IEEE*, (1981).
 "Telewriting Terminal Equipment" (Recommendation T.150) *CCITT*, (1988).

"A Family of 2-Wire, Duplex Modems Operating at Data Signalling Rates . . .", *Facsimile Recommendation V.32 CCITT*, (1988).

"*** PICFON Card Brochure", *Specom Technologies Corp.*, (Published Prior to Applicant's Invention).

"Pen Telephone Brochure, Shimadzu, (Published Prior to Applicant's Invention).

"Telewriter Product Description", *Optel Communications, Inc.*, (Published Prior to Applicant's Invention).

"Videowriter '91 Product Description", *Optel Communications, Inc.*, (1991).

European Search Report for Application No. EP 93403164 completed on Sep. 21, 1995 by Examiner Lambley; 4 pages.
 S. Casale et al., "Statistical Voice/High-Speed Data Multiplexing on a 64 KBIT/S Channel, *IEEE*, pp. 459-464, dated 1991.

T. Komiya et al., "An Approach to the Multifunction Graphic Terminal for the ISDN Environment", *IEEE*, pp. 32-36, dated 1988.

D. Gulick et al., "Interface for the ISDN to Your PC with A Voice/Data Board", *Electronic Design*, pp. 85-88, dated Dec. 10, 1987.

S. Sasaki et al., "Variable Rate Voice Coding System", *IEEE*, pp. 364-367, dated 1992.

V. Cuperman, et al., Backward Adaptive Configurations For Low-Delay Vector Excitation Coding, *Advances In Speech Coding*, pp. 13-23, dated Jan. 1, 1991.

Copy of European Search Report dated Apr. 18, 1996 by S. Lambley for Application No. EP 93403164 (5 pages).

Copy of PCT Search Report dated May 24, 1996 by C. Canosa Areste for Application No. PCT/US95/14253 (6 pages).

AT&T Microelectronics, "High Speed Data Pump Chip Sets," published in Dec. 1991.

AT&T Microelectronics, "WE DSP16C Digital Signal Processor/CODEC Preliminary Data Sheet," 32 pages, published in May, 1991.

AT&T Microelectronics, "T7540 Digital Telephone CODEC Data Sheet Addendum," pp. 1-4, published in Jul., 1991.

AT&T Microelectronics, "T7540 Digital Telephone CODEC Preliminary Data Sheet," pp. 1-64, published in Jan., 1991.

Zilog Intelligent Peripheral Controllers, "Z84C01 Z80 CPU with Clock Generator/Controller," pp. 43-73, published in 1991.

Zilog Intelligent Peripheral Controllers, "Z84C90 CMOS Z80 KIO Serial/Parallel/counter/timer," pp. 205-224, published in 1991.

U.S. West Caller ID publication, received Jul. 18, 1994, one page.

J.D. Mills, et al., "A Data and Voice System for the General Service Telephone Network," *IECON*, pp. 1143-1148, 1987.

Copy of European Search Report (Application No. EP 94304742), completed Jun. 8, 1995 by Examiner Mikkelsen.

"TechTips—A Periodic Round-up of Technical Applications, Notes, and Information on MultiTech's Data Communications Products" MultiTech Systems, vol. 2, No. 2, May 1992.

"MultiX25—X.25 PAD, The New MultiX25 PAD 8 Port X.25 Packet Assembler/Disassembler for Public and Private

Y. Akaiwa et al., "An Integrated Voice and Data Radio Access System," 1992, pp. 255-258, IEEE.

CCITT V.42, "Error-Correcting Procedures for DCES Using Asynchronous-to-Synchronous Conversion", vol. VIII, pp. 296-370, dated 1988.

IBM Technical Disclosure Bulletin, Method and Apparatus for the Statistical Multiplexing of Voice, Data, and Image Signals, 35, No. 5, pp. 409-411, dated Nov. 1992.

IBM Technical Disclosure Bulletin, Speech Data Adaptive Multiplexer, 27, No. 2, pp. 969, dated Jul. 1994.

Copy of PCT Search Report dated Apr. 25, 1996 by Areste Canosa for Application No. PCT/US95/05034 (8 pages).

Copy of PCT Search Report dated Apr. 10, 1996 by J. Lange for Application No. PCT/US95/14826 (7 pages).

Copy of PCT Search Report dated Mar. 28, 1996 by M. Vandevenne for Application No. PCT/US95/14829 (8 pages).

Canadian Application No. 2,104,701, *Computer-Based Multifunction Personal Communications System*, pp. 1-105, and 52 sheets of drawings, dated Jul. 9, 1994.

Copy of PCT Search Report for Application Serial No. PCT/US 96/11313 completed on Nov. 7, 1996, by C. Mikkelsen, 4 pages.

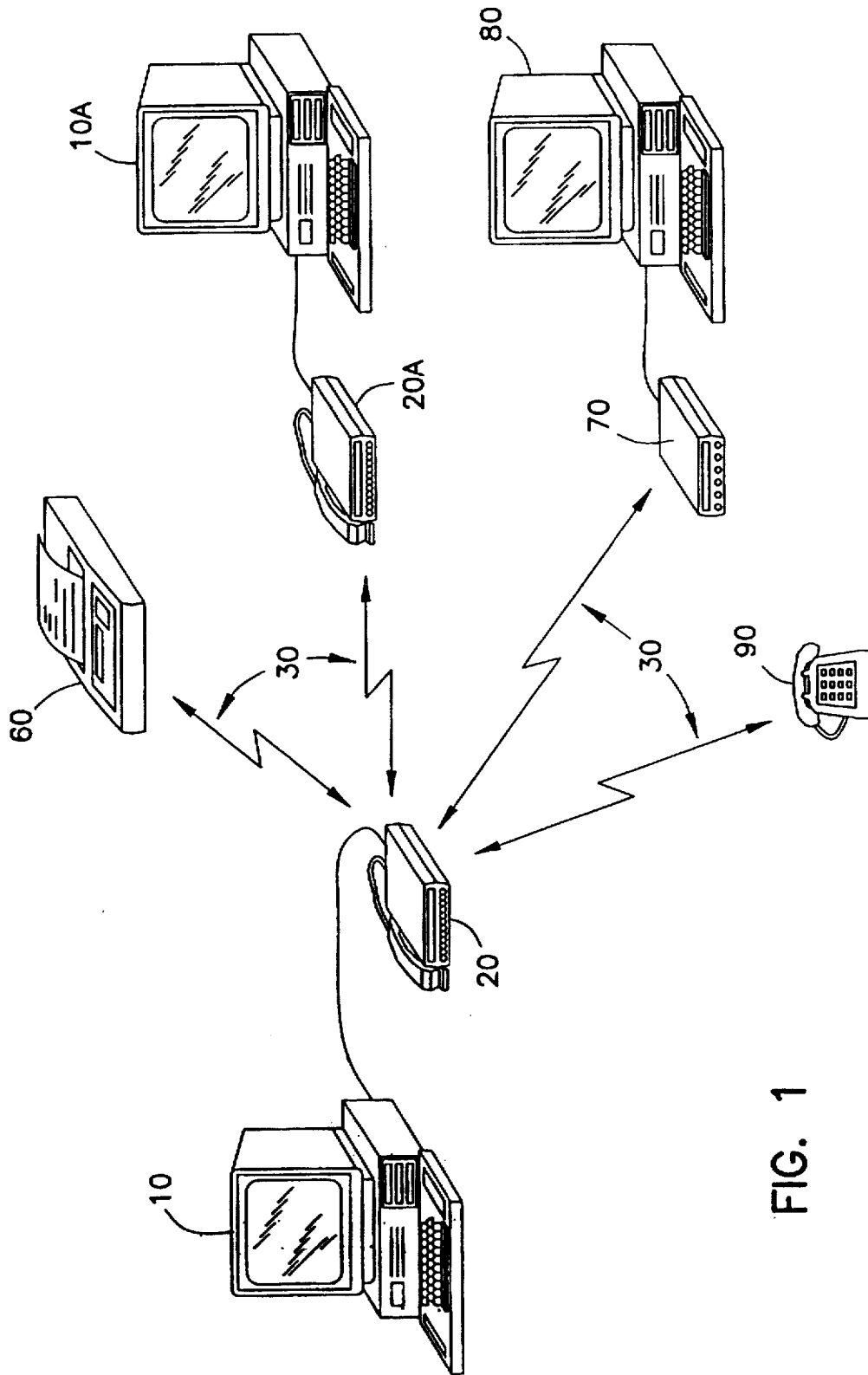

FIG. 1

Explore Litigation Insights

Docket Alarm provides insights to develop a more informed litigation strategy and the peace of mind of knowing you're on top of things.

Real-Time Litigation Alerts



Keep your litigation team up-to-date with **real-time alerts** and advanced team management tools built for the enterprise, all while greatly reducing PACER spend.

Our comprehensive service means we can handle Federal, State, and Administrative courts across the country.

Advanced Docket Research



With over 230 million records, Docket Alarm's cloud-native docket research platform finds what other services can't. Coverage includes Federal, State, plus PTAB, TTAB, ITC and NLRB decisions, all in one place.

Identify arguments that have been successful in the past with full text, pinpoint searching. Link to case law cited within any court document via Fastcase.

Analytics At Your Fingertips



Learn what happened the last time a particular judge, opposing counsel or company faced cases similar to yours.

Advanced out-of-the-box PTAB and TTAB analytics are always at your fingertips.

API

Docket Alarm offers a powerful API (application programming interface) to developers that want to integrate case filings into their apps.

LAW FIRMS

Build custom dashboards for your attorneys and clients with live data direct from the court.

Automate many repetitive legal tasks like conflict checks, document management, and marketing.

FINANCIAL INSTITUTIONS

Litigation and bankruptcy checks for companies and debtors.

E-DISCOVERY AND LEGAL VENDORS

Sync your system to PACER to automate legal marketing.