

[54] **COMPUTER MOUSE OR KEYBOARD INPUT DEVICE UTILIZING CAPACITIVE SENSORS**

[75] Inventors: **Robert A. Boie**, Westfield; **Laurence W. Ruedisueli**, Berkeley Heights; **Eric R. Wagner**, South Plainfield, all of N.J.

[73] Assignee: **AT&T IPM Corp.**, Coral Gables, Fla.

[*] Notice: The portion of the term of this patent subsequent to May 12, 2009, has been disclaimed.

[21] Appl. No.: **11,040**

[22] Filed: **Jan. 29, 1993**

[51] Int. Cl.⁶ **H03K 17/94**

[52] U.S. Cl. **341/33; 345/174**

[58] Field of Search **341/33; 178/18, 178/19; 345/174**

[56] **References Cited**

U.S. PATENT DOCUMENTS

4,733,222	3/1988	Evans	341/33
4,737,768	4/1988	Lewiner et al.	341/33
4,772,874	9/1988	Hasegawa	341/33
4,806,709	2/1989	Evans	178/19
4,852,443	8/1989	Duncan et al.	84/1.04
4,893,071	1/1990	Miller	324/660
4,972,496	11/1990	Sklarew	178/18 X

5,012,124	4/1991	Hollaway	341/33
5,016,008	5/1991	Gruaz et al.	341/33
5,113,041	5/1992	Blonder et al.	178/18
5,122,623	6/1992	Zank et al.	178/19

OTHER PUBLICATIONS

"The Art of Electronics," Second Edition, Horowitz and Hill, p. 889, Cambridge University Press (1989).

Primary Examiner—Brent Swarthout
Assistant Examiner—Thomas J. Mullen, Jr.
Attorney, Agent, or Firm—Geoffrey D. Green

[57] **ABSTRACT**

A computer input device for use as a computer mouse or keyboard comprises a thin, insulating surface covering an array of electrodes. Such electrodes are arranged in a grid pattern and can be connected in columns and rows. Each column and row is connected to circuitry for measuring the capacitance seen by each column and row. The position of an object, such as a finger or handheld stylus, with respect to the array is determined from the centroid of such capacitance values, which is calculated in a microcontroller. For applications in which the input device is used as a mouse, the microcontroller forwards position change information to the computer. For applications in which the input device is used as a keyboard, the microcomputer identifies a key from the position of the touching object and forwards such key identity to the computer.

10 Claims, 6 Drawing Sheets

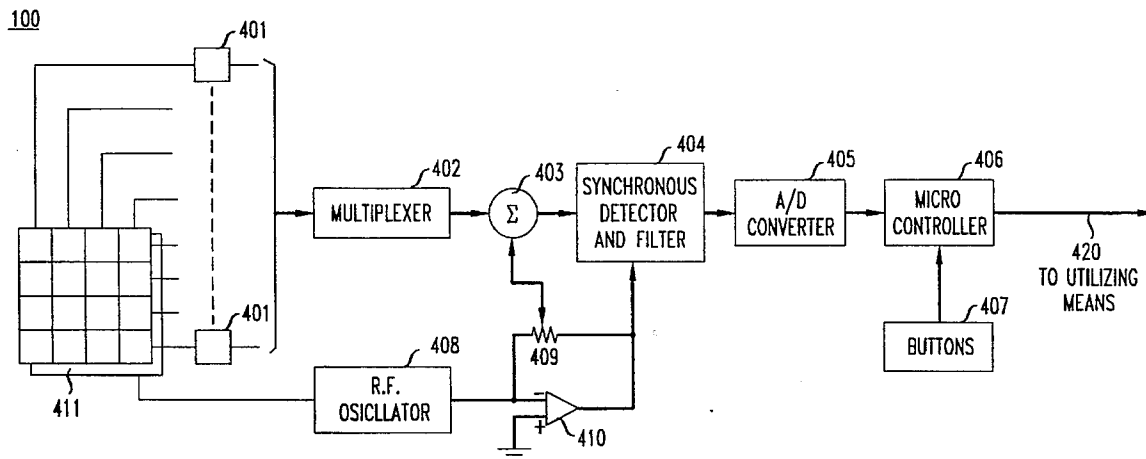

FIG. 1

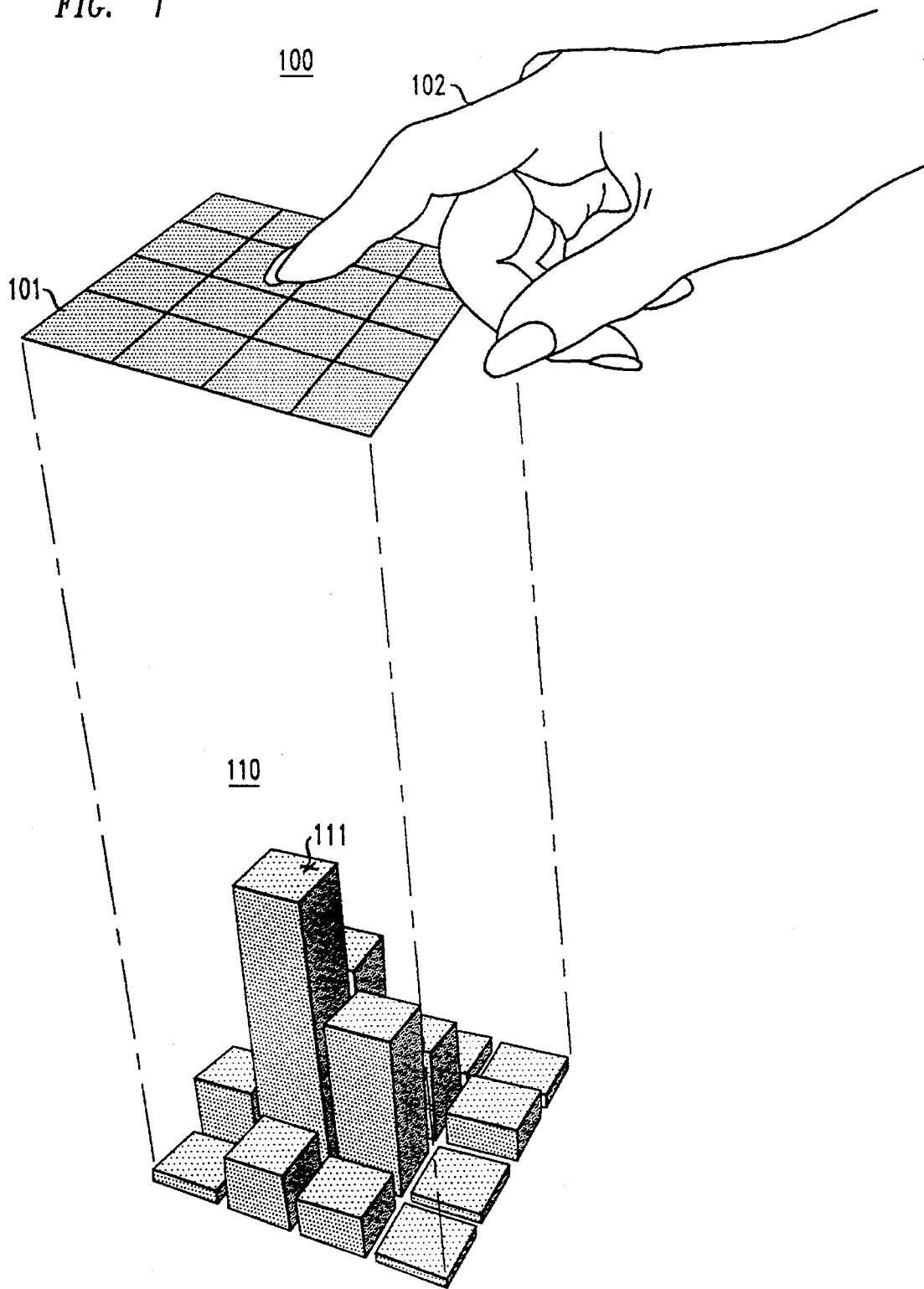

FIG. 2

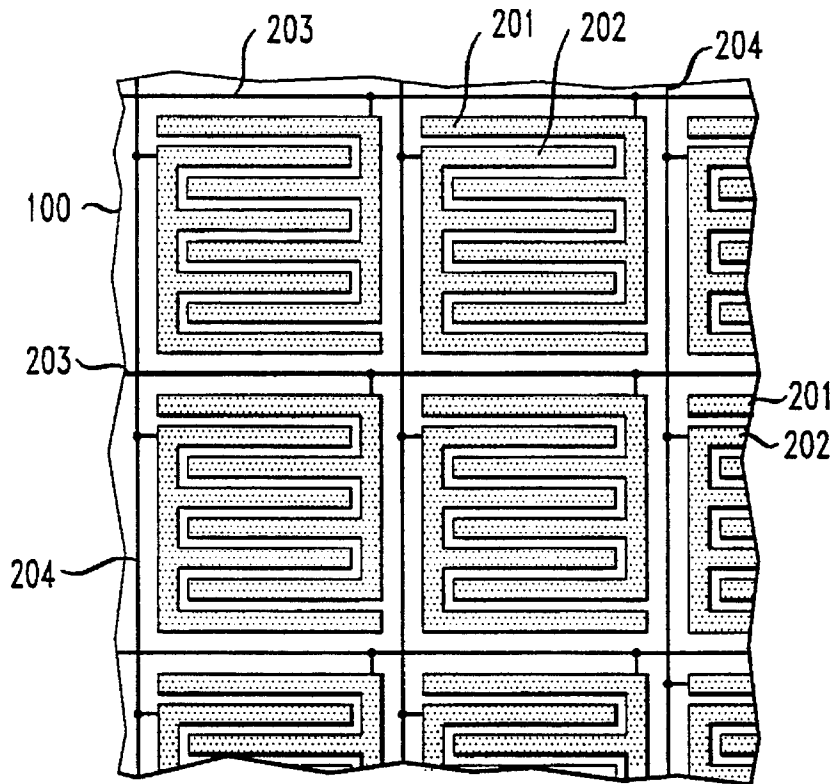

FIG. 3

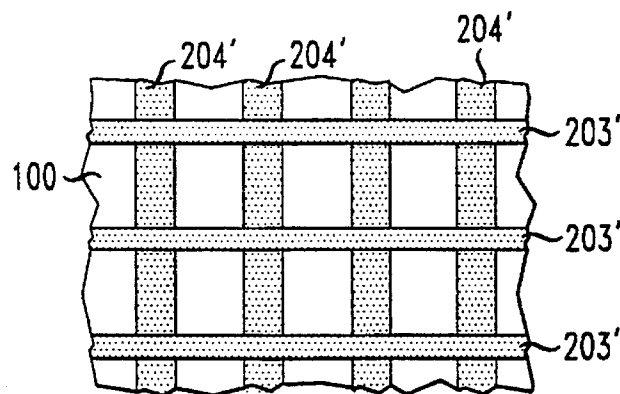

FIG. 4

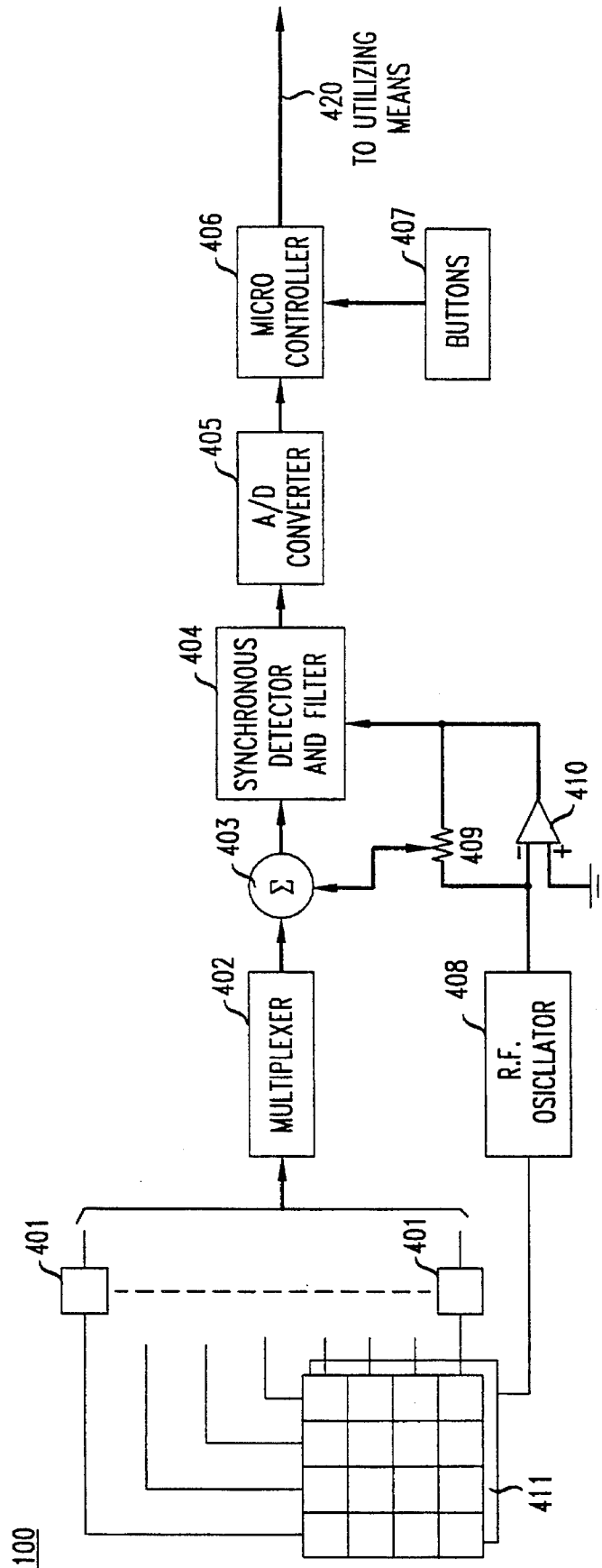

FIG. 5

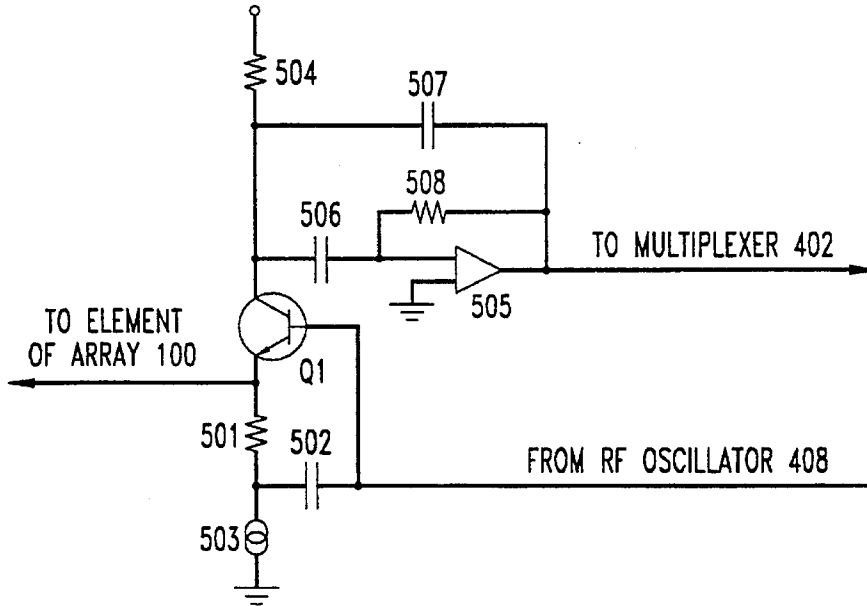
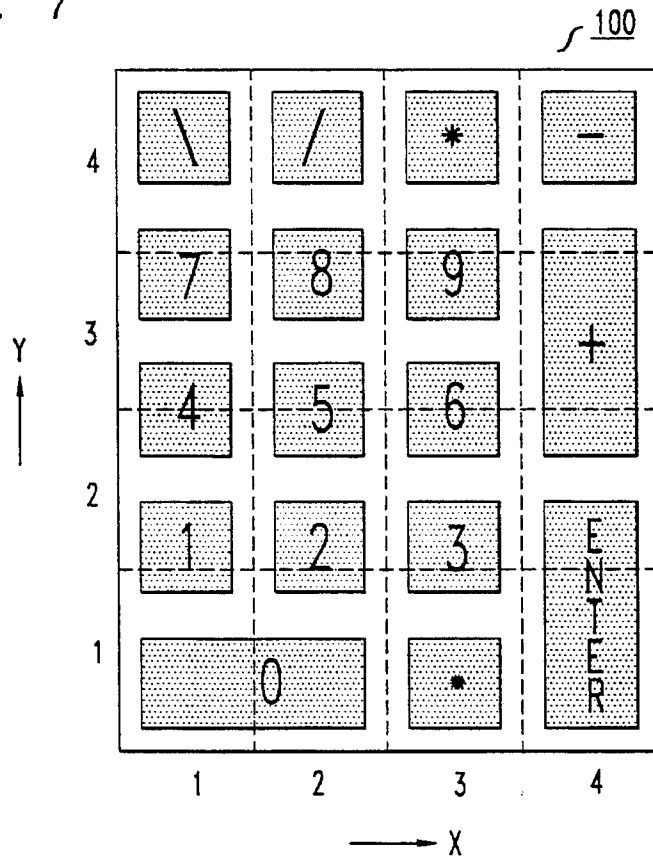

FIG. 7



Explore Litigation Insights

Docket Alarm provides insights to develop a more informed litigation strategy and the peace of mind of knowing you're on top of things.

Real-Time Litigation Alerts



Keep your litigation team up-to-date with **real-time alerts** and advanced team management tools built for the enterprise, all while greatly reducing PACER spend.

Our comprehensive service means we can handle Federal, State, and Administrative courts across the country.

Advanced Docket Research



With over 230 million records, Docket Alarm's cloud-native docket research platform finds what other services can't. Coverage includes Federal, State, plus PTAB, TTAB, ITC and NLRB decisions, all in one place.

Identify arguments that have been successful in the past with full text, pinpoint searching. Link to case law cited within any court document via Fastcase.

Analytics At Your Fingertips



Learn what happened the last time a particular judge, opposing counsel or company faced cases similar to yours.

Advanced out-of-the-box PTAB and TTAB analytics are always at your fingertips.

API

Docket Alarm offers a powerful API (application programming interface) to developers that want to integrate case filings into their apps.

LAW FIRMS

Build custom dashboards for your attorneys and clients with live data direct from the court.

Automate many repetitive legal tasks like conflict checks, document management, and marketing.

FINANCIAL INSTITUTIONS

Litigation and bankruptcy checks for companies and debtors.

E-DISCOVERY AND LEGAL VENDORS

Sync your system to PACER to automate legal marketing.