

Ex. PGS 1067

[54] **SEISMIC VIBRATOR CONTROL SYSTEM**

[75] Inventors: **Bobby J. Thomas; Billy J. Heath,**
both of Ponca City, Okla.

[73] Assignee: **Conoco Inc.,** Ponca City, Okla.

[21] Appl. No.: **253,207**

[22] Filed: **Apr. 13, 1981**

[51] Int. Cl.³ **G01V 1/155; G01V 1/143**

[52] U.S. Cl. **367/189; 181/107**

[58] Field of Search 367/23, 41, 49, 189;
364/421; 181/107; 73/662

[56] **References Cited**

U.S. PATENT DOCUMENTS

3,440,599	4/1969	Waters et al.	367/189
3,460,648	8/1969	Brown et al.	367/189
3,739,870	6/1973	Pelton et al.	367/189
3,886,493	5/1975	Fair	367/189
4,168,485	9/1979	Payton et al.	367/189

Primary Examiner—Nelson Moskowitz
Attorney, Agent, or Firm—William J. Miller

[57] **ABSTRACT**

A method and apparatus for construction of a seismic vibrator control signal which comprises manually selecting sweep parameter data values for starting frequency, ending frequency, sweep time and taper time and inputting to an addressable storage medium. Thereafter, determining for each of a plurality of sample points throughout the sweep time, the sweep rate of change per sample point and the accumulated frequency value per sample point, and outputting in real time the digital sweep values for each successive sample point, and subsequently converting and smoothing said successive digital sweep values to an analog control signal of the selected frequency, relative amplitude and duration of sweep length.

12 Claims, 5 Drawing Figures

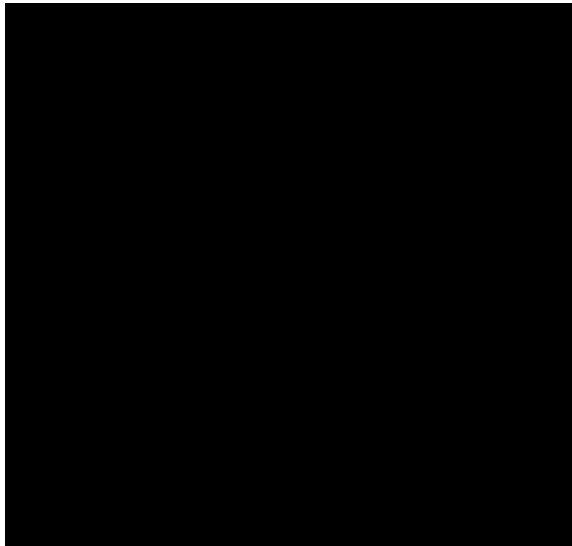

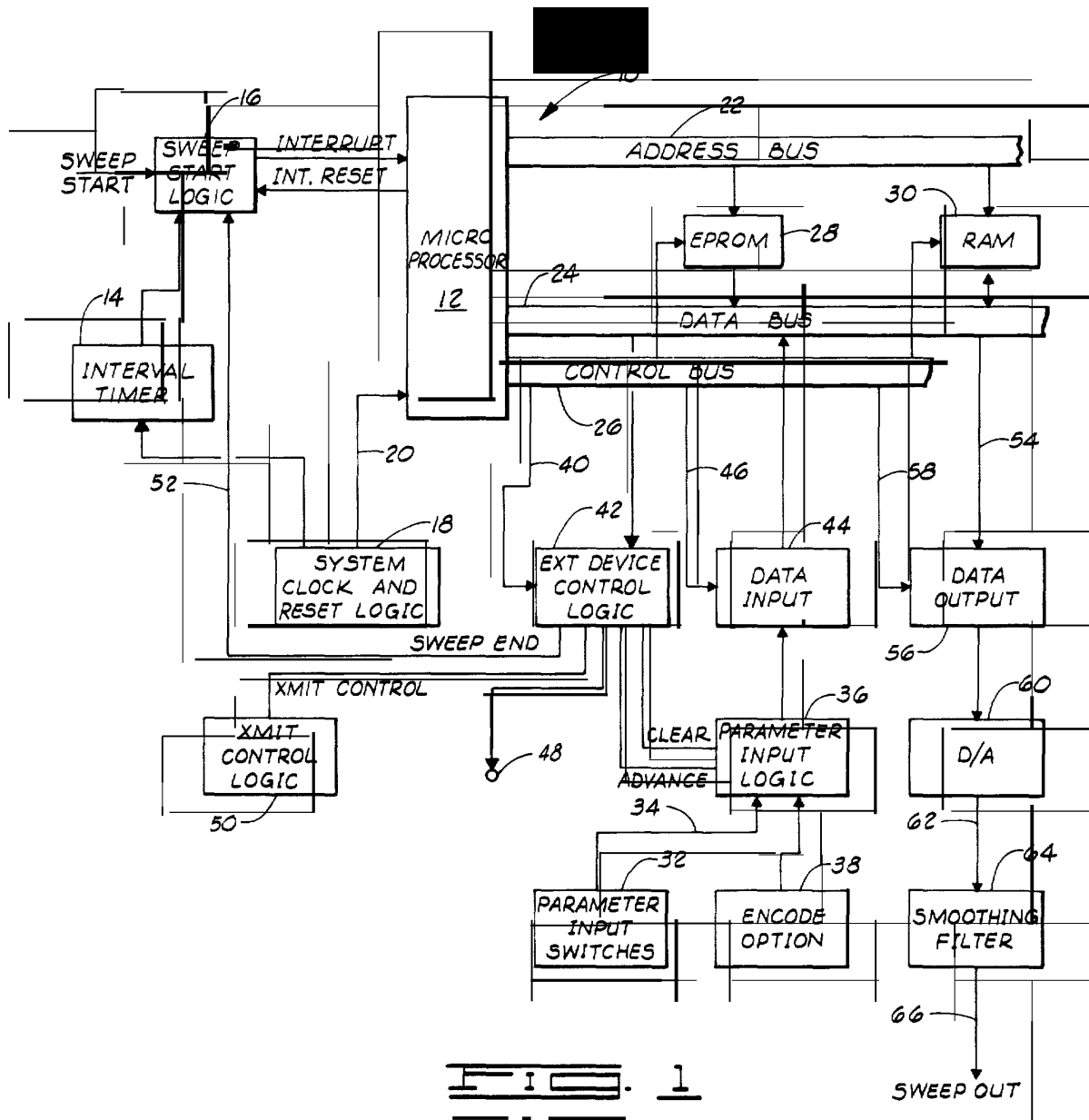

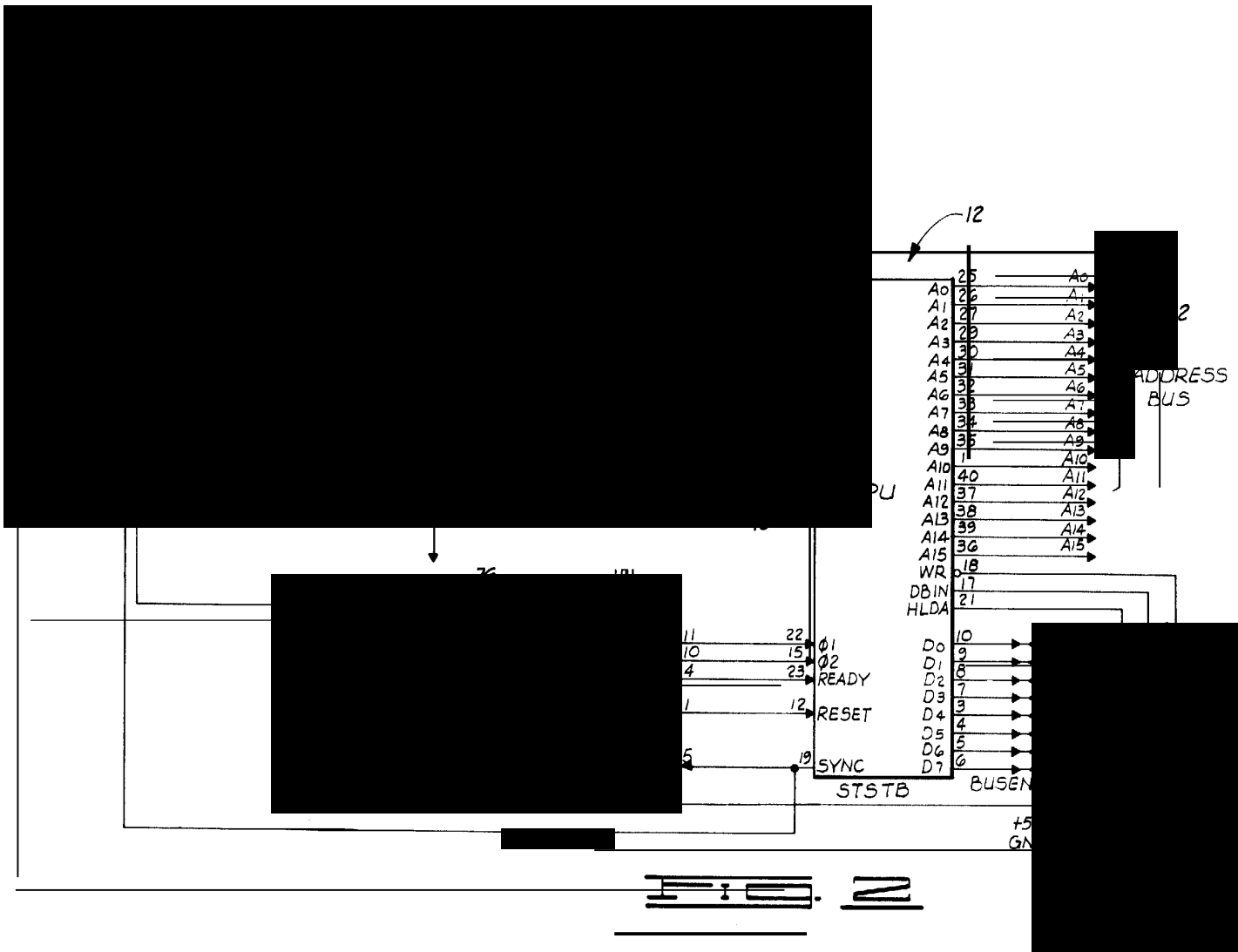
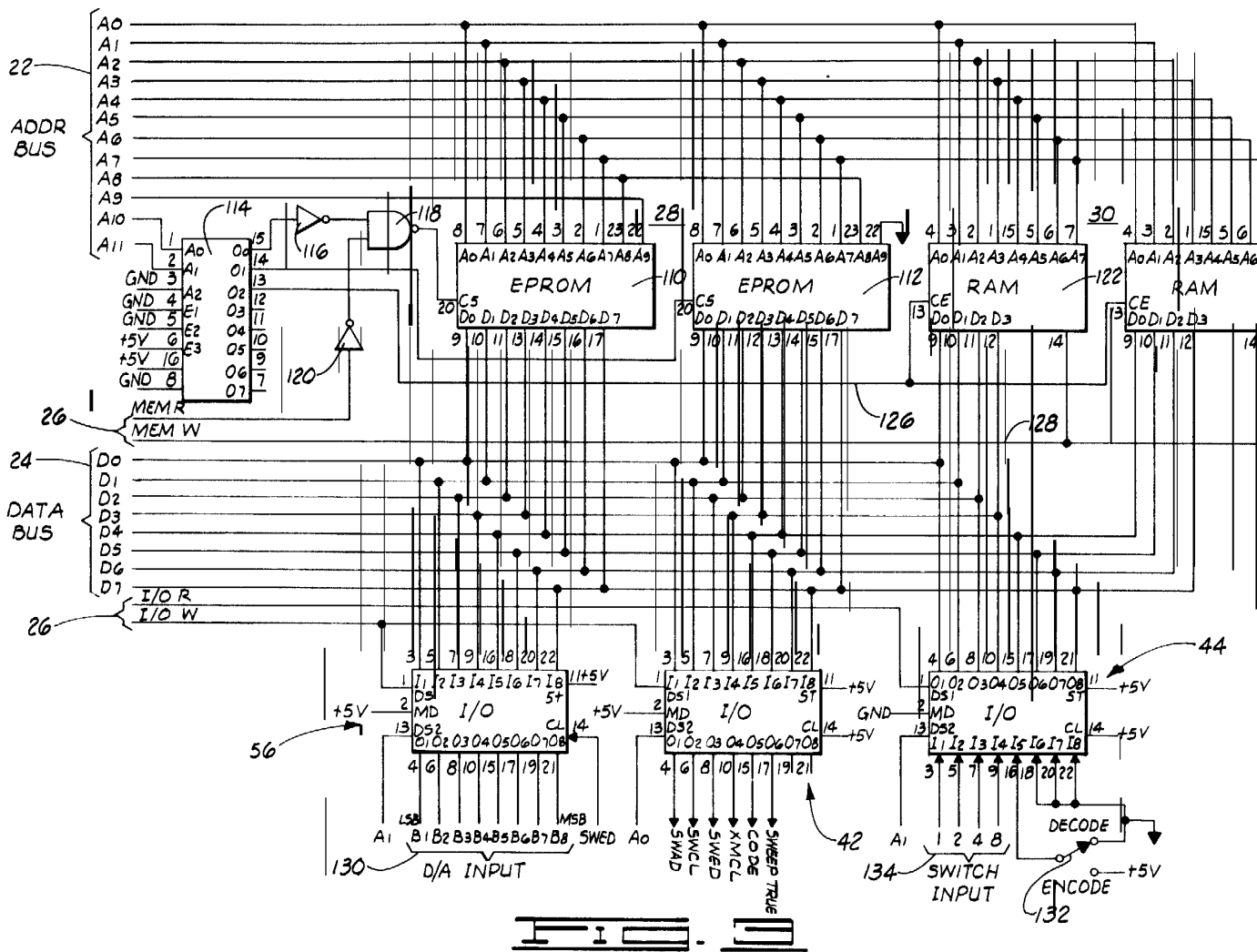

FIG. 2



Explore Litigation Insights

Docket Alarm provides insights to develop a more informed litigation strategy and the peace of mind of knowing you're on top of things.

Real-Time Litigation Alerts



Keep your litigation team up-to-date with **real-time alerts** and advanced team management tools built for the enterprise, all while greatly reducing PACER spend.

Our comprehensive service means we can handle Federal, State, and Administrative courts across the country.

Advanced Docket Research



With over 230 million records, Docket Alarm's cloud-native docket research platform finds what other services can't. Coverage includes Federal, State, plus PTAB, TTAB, ITC and NLRB decisions, all in one place.

Identify arguments that have been successful in the past with full text, pinpoint searching. Link to case law cited within any court document via Fastcase.

Analytics At Your Fingertips



Learn what happened the last time a particular judge, opposing counsel or company faced cases similar to yours.

Advanced out-of-the-box PTAB and TTAB analytics are always at your fingertips.

API

Docket Alarm offers a powerful API (application programming interface) to developers that want to integrate case filings into their apps.

LAW FIRMS

Build custom dashboards for your attorneys and clients with live data direct from the court.

Automate many repetitive legal tasks like conflict checks, document management, and marketing.

FINANCIAL INSTITUTIONS

Litigation and bankruptcy checks for companies and debtors.

E-DISCOVERY AND LEGAL VENDORS

Sync your system to PACER to automate legal marketing.