

Ex. PGS 1008

Sept. 20, 1971

R. C. WEESE

3,605,674

UNDERWATER CABLE CONTROLLER

Filed Sept. 8, 1969

2 Sheets-Sheet 1

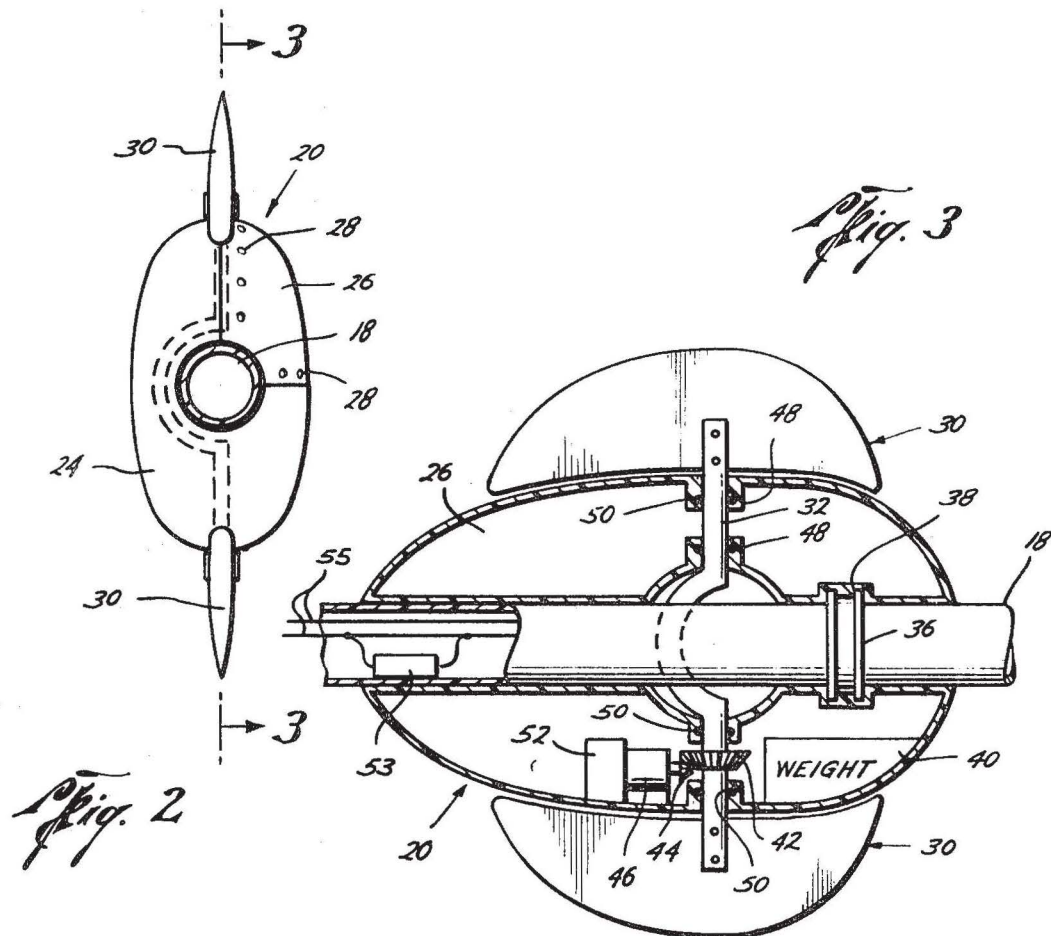
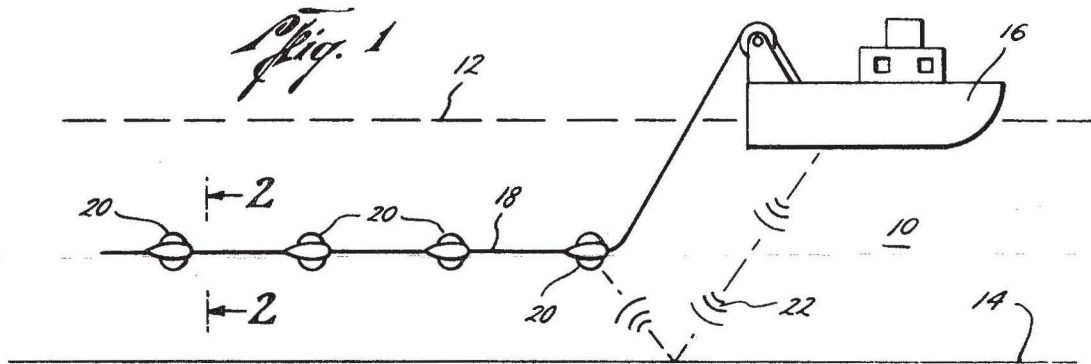

Raymond C. Weese
INVENTOR.

BY James F. Weiler
William A. Stout
Dudley R. Dolje, Jr.
Henry W. Hays
ATTORNEYS

Sept. 20, 1971

R. C. WEESE

3,605,674

UNDERWATER CABLE CONTROLLER

Filed Sept. 8, 1969

2 Sheets-Sheet 2

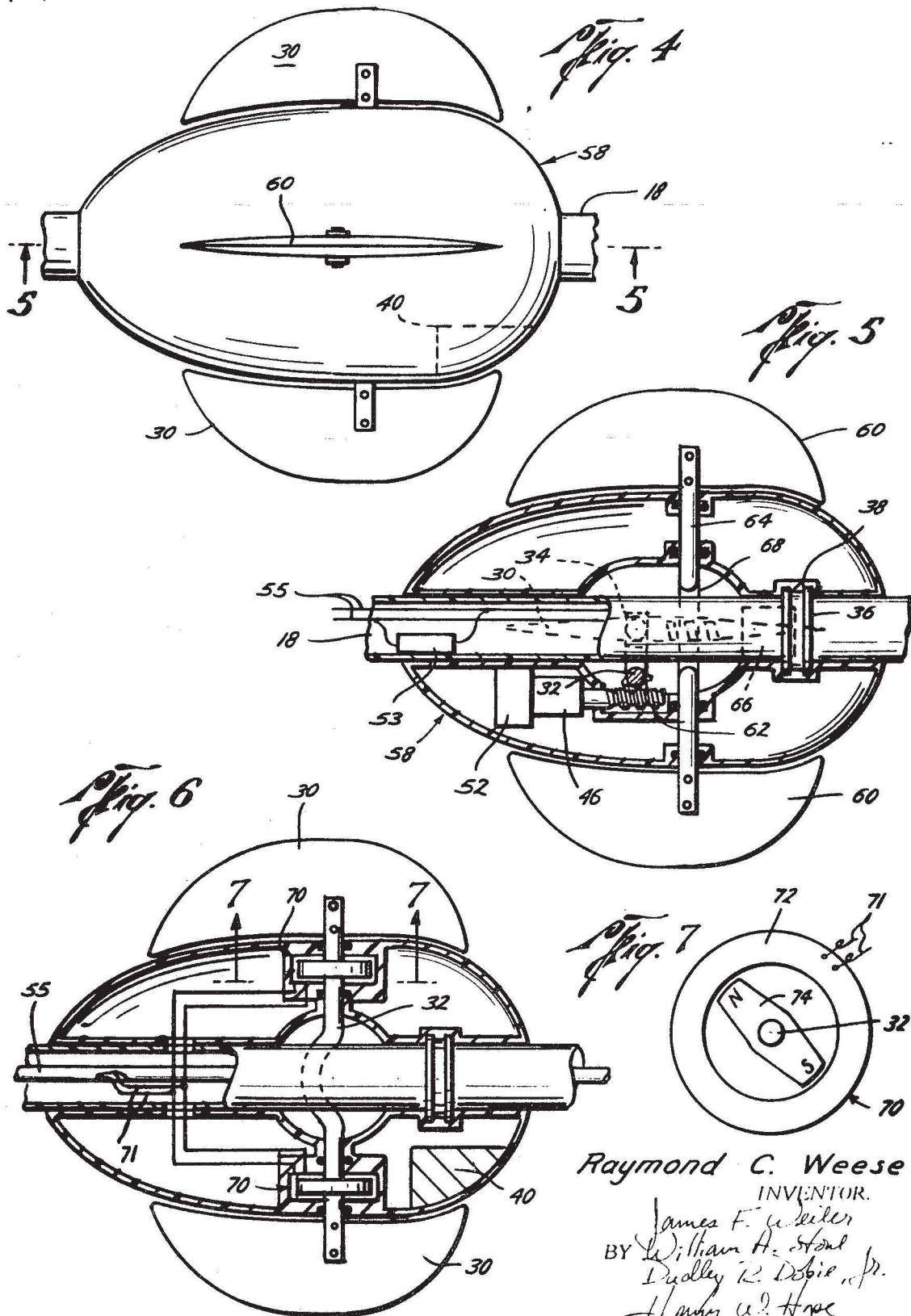

Raymond C. Weese
INVENTOR.
James F. Weiler
BY William H. Stand
Dudley R. Dobie, Jr.
Henry W. Hove
ATTORNEYS

1

3,605,674
UNDERWATER CABLE CONTROLLER
Raymond C. Weese, Houston, Tex., assignor to
Dresser Industries, Inc., Dallas, Tex.
Filed Sept. 8, 1969, Ser. No. 855,939
Int. Cl. B63b 21/00
U.S. Cl. 114—235B **9 Claims**

ABSTRACT OF THE DISCLOSURE

The present invention is directed to controllers for use in connection with cables that are towed beneath a body of water in order to maintain the cable in a desired position. The controller employs control planes or vanes vertically disposed on opposite sides of the controller for maintaining position in a horizontal plane, and vanes horizontally disposed on opposite sides to maintain position in a vertical plane. Standard reversible D.C. motors or D.C. torque motors are used to control the position of the vanes in response to signals transmitted from the towing or other vessel. A yoke arrangement allows simultaneous operation of each pair of vanes.

BACKGROUND OF THE INVENTION

The orientation of objects towed below the surface of a body of water is today required in many areas dealing with the use, exploration and development of the earth's water bodies and the land areas lying beneath them. Perhaps the most common field requiring this is marine seismic exploration of geological formations in water covered areas. This technique encompasses the reflecting of seismic signals off of the subsurface layering down to depths of 5 or 6 miles and picking up these reflected signals by a seismic cable towed by a vessel. These cables are known in the field as "streamers," and are towed beneath the water's surface to avoid interference by waves with the cable's position or the configuration that it assumes and to aid in receiving the reflected signals.

In order that the signals received can be properly and correctly interpreted, the position of the cable relative to the water surface, as well as to the bottom of the body of water must be known and maintained as uniformly as possible. The streamer, up to two miles in length, must also be maintained in a relatively straight-line horizontal position. Means are, therefore, required to resist action such as cross-currents which would disrupt the straight-line configuration of the cable. In addition, it is desirable to have means available to change the position of the cable to move it closer to or further away from the bottom or surface as conditions change.

In the past, various means have been devised to achieve the above results such as disclosed in the U.S. Patent Nos. 3,371,739, 3,331,050, 3,386,526 and 1,690,578. Such apparatus as disclosed in these patents, however, as well as other such devices, suffer from certain shortcomings which the present invention is designed to overcome.

Such prior devices are quite often controllers that are actuated by pressure sensitive and responsive means to maintain them at a preset and predetermined level below the surface of the water. This, of course, can be rather inconsistent and the pressure responsive means are often subject to malfunctions due to exposure to salt water and the like. Furthermore, these devices suffer from the obvious disadvantage of not being able to readjust the position of the cable once the controllers have been set and let out under tow. These controllers must, of course, be set for the depth desired before they are placed in the water. Thus, control is maintained over the controllers

2

change in position be desired, or should one of the controllers used become inaccurate for some reason, thereby resulting in a change of position of the cable or a portion thereof.

5 Other devices rely on relatively complex control apparatus to provide some control over the controllers once they are in position behind the towing vessel. These devices can often be unreliable, however, and are somewhat expensive due to the complex equipment involved. 10 It should be remembered that usually a plurality of such underwater controllers are used on any such cable, and a malfunction in any one of these could result in an inaccurate and unreliable survey. Thus a dependable device is preferable and one that may be controlled from the ship so that adjustments can be made should the controller move out of position for some reason without the expensive and time-consuming method of reeling in the cable.

SUMMARY OF THE PRESENT INVENTION

The present invention seeks to overcome the above noted disadvantages by providing a relatively simple device which as a result gives extremely dependable performance. The controller which is the subject of the present invention utilizes a pair of vertically disposed vanes or rudder blades positioned on opposite sides of the controller body. These vertically disposed vanes are used to control the position of the controller in a horizontal plane, and a similar pair of horizontally disposed vanes are used to control the position of the controller in a vertical plane. It is, of course, anticipated that control in either the vertical or horizontal plane would not be desired in some situations, and accordingly, provision is made for the pairs of vanes to operate independently of each other. Furthermore, one pair of vanes may be omitted if necessary.

Simplified actuating means are employed to provide the movement of the vanes, and in turn, the control of the controllers and the attached cable. The actuating means is comprised of rotatably mounted yoke means extending between the vanes making up each pair, so that both vanes in each pair operate simultaneously. A reversible D.C. motor or D.C. torque motor is used to rotate the yoke means. This, in turn, rotates the vanes the desired amount. The motors are controlled by signals transmitted from the towing vessel, and being reversible, can actuate the vanes in either direction. Thus more than adequate control is provided for the controllers by this relatively inexpensive and simple arrangement of parts described herein.

It is, therefore, an object of the present invention to provide control means for the control and positioning of cable and the like while it is being towed beneath the surface of a body of water.

A still further object of the present invention is to provide such controllers which are comprised of relatively simple and economical arrangements of parts with the result of decreased costs and increased dependability.

It is the further object of the present invention to provide cable controllers which may be secured to the device to be controlled and which utilizes at least one pair of vanes connected by a yoke arrangement and rotatable in either direction.

Still another object of the present invention is to provide such a controller which utilizes two sets of vanes that are rotatable in either direction about axis perpendicular to each other, and which utilizes simplified control and actuating means for the positioning of the vanes.

Still another object of the present invention is to provide such apparatus which may be constructed in an inexpensive manner and which will provide long life con-

submersed and dependable performance with little maintenance time or cost involved.

Other and further objects, features and advantages will be apparent from the following description of a presently preferred embodiment of the invention, given for the purpose of disclosure when taken in conjunction with the accompanying drawings.

BRIEF DESCRIPTION OF THE DRAWINGS

Like character references designate like parts throughout the several views of the drawings, which views are as follows:

FIG. 1 is a partially schematic view of the present invention as it would be employed to control a cable being towed behind a vessel,

FIG. 2 is a front view of one of the cable controllers as viewed along section lines 2—2 of FIG. 1 but on an enlarged scale,

FIG. 3 is a section view of the controller of FIG. 2 as viewed along section lines 3—3 of FIG. 2,

FIG. 4 is a side view of a second embodiment of the controller of the present invention,

FIG. 5 is a section view of the second embodiment as seen along section lines 5—5 of FIG. 4,

FIG. 6 is a section view of the first embodiment but showing different actuating means for the vanes, and

FIG. 7 is an end view of one of the actuating means shown in FIG. 6 as seen along lines 7—7 of FIG. 6.

BRIEF DESCRIPTION OF THE PREFERRED EMBODIMENT

For purposes of description, the present invention will be described as used with a seismic cable. It should be understood, however, that the controller may be used for any such device that is to be towed beneath the surface of a body of water at a predetermined depth or over which control is desired. Other uses of the present invention would include such things as cables towing magnetometers, used to measure the earth's magnetic field, or cables towed by mine-sweepers.

Turning now to FIG. 1, there is shown a body of water generally indicated by the numeral 10 having a surface 12 and a bottom 14. A vessel 16 is illustrated as towing a cable 18. As can be seen, this cable is maintained beneath the surface of the water 12 but a certain distance above the bottom 14. The position of the cable relative to the water surface and to the bottom is usually determined by the use of a fathommeter to indicate the depth of the water and by the use of depth detectors carried in the cable to indicate the depth of the cable. This is accomplished by means of the cable controllers of the present invention, which controllers are generally indicated by the numeral 20. Also from the towing vessel 16, seismic waves 22 are directed toward the bottom 14 by which they are reflected back toward the seismic cable 18.

Turning now to FIGS. 2 and 3, a controller of the present invention is shown. The controller is made up of a body 24 having a removable section 26 to allow the body to be secured about the cable 18. The removable section 26 is secured to the remainder of the body by any suitable means such as screws 28. In the embodiment of FIGS. 2 and 3, only one pair of vanes 30 is utilized. Accordingly, this embodiment will allow control of the controller and connected cable only in a horizontal plane.

The vanes 30 are connected together by means of the yoke 32 which has a curved central section 34 to allow passage of the cable 18. A ring 36 is fixedly secured to the cable 18 and mates with a recess 38 in the body sections 24 and 26 to secure the cable controller 20 at a desired and fixed position on the cable. When the removable portion 26 is secured to the body, the recesses 38 are satisfactorily secured about the ring portion 36 to prevent the controller from slipping longitudinally on

the cable. The cable controller can, however, rotate about the cable, and to maintain proper orientation of the controller relative to the water surface 12 and bottom 14, a weight 40 is secured at a suitable location in the body 24. This weight 40 will insure that the vanes 30, as well as the second pair of vanes in the embodiment disclosed in FIGS. 4 and 5, are maintained in the proper vertical and horizontal planes, so as to give full and accurate control over the controller.

A bevel gear 42 is connected to the yoke 34 and a second bevel gear 44 is connected to the shaft of a reversible D.C., stopper motor 46. This motor 46 is again secured to the body 24, and as one can readily tell, operation of the motor 46 will cause the gear 42 to rotate along with the yoke 34 to which gear 42 is fixedly secured. It should be noted that the yoke 34 is rotatably mounted in the body 24 and has suitable bearing members 48 for this purpose. These bearing members also contain sealing members 50 to prevent the flow of water into the body, thereby possibly damaging the actuating elements of the controller.

Fixedly secured to D.C. motor 46 is a receiver 52, which may also be secured to the body 24 if desired. The receiver 52 contains a power source for the motor such as a battery. The purpose of the receiver 52 is to receive signals transmitted from a transmitter 53 carried by the cable (a transmitter being positioned at each controller) to actuate the motor 46 accordingly. Appropriate wiring 55 leads through the cable to carry signals from the vessel to the transmitters 53. By proper signals, the motor 46 may be actuated in either direction, thereby rotating the vanes in either direction.

In operation, horizontal ranging sonar may be used on the towing vessels to monitor the cable and its position. This sonar can be viewed or photographed at will at the master console of the control equipment on the vessel, and thus, it provides a continuous monitor over the position of the cable. Other techniques may also be used to monitor the position of the cable. For example, a system marketed by Edo-Western of Salt Lake City, Utah, could be used. This system employs a number of transducers in the cable 18 which periodically transmit pulses through the water. Two additional cables are towed by the vessel 16, one on each side and each carrying receivers or hydrophones. Each pulse will be received by both hydrophones simultaneously if the cable is properly centered. If it is not, one hydrophone will receive the pulse first and the time lag between it and the second pulsing up of the pulse will determine how far out of position the cable is. In addition, these transducers will be positioned throughout the length of the cable so that the operators can determine what part of the cable is out of position. This can be accomplished, of course, by sending pulses at various times from the different transducers, sending different pulses from each, or by noting that the pulse from the first transducer will be received first, the second transducer's a short time later, and so on. It should perhaps be mentioned again that the position of the cable depthwise is determined by use of depth detectors in the cable and a fathommeter.

Should the cable for some reason move out of position, appropriate signals can be transmitted to the receiver 52 which will actuate the motor 46 accordingly. The change in vane position is achieved, therefore, by supplying D.C. current in one direction or the other for a specific amount of time. A change in the direction of current flow will, of course, reverse the direction of rotation of the motor shaft and thereby, provide the means to rotate the vanes in either direction. Time of D.C. current flow is convertible into degrees of vane angle change and charts of such may be made up for ease of reference by the operator. Where a stopper motor is used, such as those manufactured by the Clifton Division of Litton Industries, each electrical signal or pulse transmitted to the receiver will result in the rotation of the motor shaft through a dia-

Explore Litigation Insights

Docket Alarm provides insights to develop a more informed litigation strategy and the peace of mind of knowing you're on top of things.

Real-Time Litigation Alerts



Keep your litigation team up-to-date with **real-time alerts** and advanced team management tools built for the enterprise, all while greatly reducing PACER spend.

Our comprehensive service means we can handle Federal, State, and Administrative courts across the country.

Advanced Docket Research



With over 230 million records, Docket Alarm's cloud-native docket research platform finds what other services can't. Coverage includes Federal, State, plus PTAB, TTAB, ITC and NLRB decisions, all in one place.

Identify arguments that have been successful in the past with full text, pinpoint searching. Link to case law cited within any court document via Fastcase.

Analytics At Your Fingertips



Learn what happened the last time a particular judge, opposing counsel or company faced cases similar to yours.

Advanced out-of-the-box PTAB and TTAB analytics are always at your fingertips.

API

Docket Alarm offers a powerful API (application programming interface) to developers that want to integrate case filings into their apps.

LAW FIRMS

Build custom dashboards for your attorneys and clients with live data direct from the court.

Automate many repetitive legal tasks like conflict checks, document management, and marketing.

FINANCIAL INSTITUTIONS

Litigation and bankruptcy checks for companies and debtors.

E-DISCOVERY AND LEGAL VENDORS

Sync your system to PACER to automate legal marketing.