



US008004497B2

(12) **United States Patent**
XiaoPing

(10) **Patent No.:** **US 8,004,497 B2**
(45) **Date of Patent:** **Aug. 23, 2011**

- (54) **TWO-PIN BUTTONS**
- (75) Inventor: **Jiang XiaoPing**, Shanghai (CN)
- (73) Assignee: **Cypress Semiconductor Corporation**,
San Jose, CA (US)
- (*) Notice: Subject to any disclaimer, the term of this patent is extended or adjusted under 35 U.S.C. 154(b) by 1012 days.
- (21) Appl. No.: **11/437,517**
- (22) Filed: **May 18, 2006**

4,614,937 A	9/1986	Poujois	
4,728,932 A	3/1988	Atherton	
4,736,191 A	4/1988	Matzke et al.	
4,825,147 A	4/1989	Cook et al.	
4,831,325 A	5/1989	Watson, Jr.	
5,008,497 A	4/1991	Asher	
5,214,388 A	5/1993	Vranish et al.	
5,237,879 A	8/1993	Speeter	
5,305,017 A	4/1994	Gerpheide	
5,323,158 A	6/1994	Ferguson, Jr.	
5,373,245 A	12/1994	Vranish	
5,386,219 A	1/1995	Greanias et al.	
5,518,078 A *	5/1996	Tsujioka et al.	178/18.05
5,541,580 A	7/1996	Gerston et al.	
5,670,915 A	9/1997	Cooper et al.	
5,760,852 A	6/1998	Wu et al.	

(Continued)

- (65) **Prior Publication Data**
US 2007/0268265 A1 Nov. 22, 2007

FOREIGN PATENT DOCUMENTS

- EP 0574213 A2 12/1993
(Continued)

- (51) **Int. Cl.**
G06F 3/041 (2006.01)
G06F 3/045 (2006.01)
G06F 3/033 (2006.01)
- (52) **U.S. Cl.** **345/173**; 345/174; 345/179; 178/18.01;
178/18.06
- (58) **Field of Classification Search** 345/173
See application file for complete search history.

OTHER PUBLICATIONS

Ryan Seguine, et al., "Layout Guidelines for PSoC™ CapSense™", Cypress Application Note AN2292, Revision B, Oct. 31, 2005, pp. 1-15.

(Continued)

Primary Examiner — Bipin Shalwala
Assistant Examiner — Benyam Ketema

(56) **References Cited**

U.S. PATENT DOCUMENTS

3,979,745 A	9/1976	Bishop
4,039,940 A	8/1977	Butler et al.
4,113,378 A	9/1978	Wirtz
4,145,748 A	3/1979	Eichelberger et al.
4,193,063 A	3/1980	Hitt et al.
4,238,711 A	12/1980	Wallot
4,264,903 A	4/1981	Bigelow
4,266,144 A	5/1981	Bristol
4,292,604 A	9/1981	Embree et al.
4,305,135 A	12/1981	Dahl et al.
4,586,260 A	5/1986	Baxter et al.

(57) **ABSTRACT**

An apparatus and method for detecting a presence of a conductive object on a sensing device, and recognizing three or more button operations performed by the conductive object using two sensing areas of the sensing device. The sensing device may include first, second, and third sensor elements. The third sensor element may include two electrically isolated portions coupled to the first and second sensor elements.

20 Claims, 10 Drawing Sheets

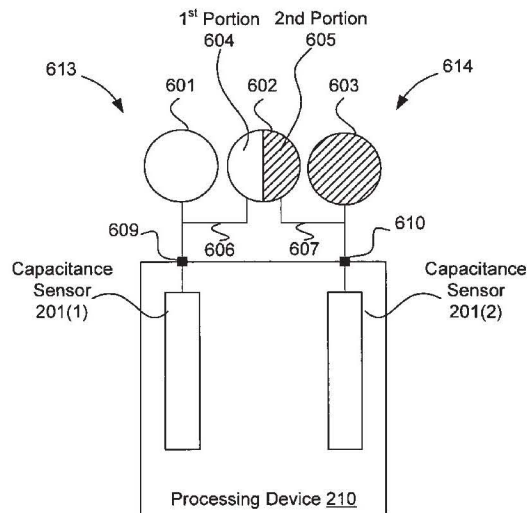

U.S. PATENT DOCUMENTS

5,801,340 A 9/1998 Peter
 5,920,309 A 7/1999 Bisset et al.
 5,942,733 A 8/1999 Allen et al.
 6,037,929 A 3/2000 Ogura et al.
 6,060,957 A 5/2000 Kodrnja et al.
 6,145,850 A 11/2000 Rehm
 6,184,871 B1 2/2001 Teres et al.
 6,188,391 B1 2/2001 Seely et al.
 6,191,723 B1 2/2001 Lewis
 6,297,811 B1 10/2001 Kent
 6,353,200 B1 3/2002 Schwankhart
 6,366,099 B1 4/2002 Reddi
 6,377,129 B1 4/2002 Rhee et al.
 6,380,931 B1 4/2002 Gillespie et al.
 6,448,911 B1 9/2002 Somayajula
 6,490,203 B1 12/2002 Tang
 6,535,200 B2 3/2003 Philipp
 6,577,140 B1 6/2003 Wenman
 6,583,632 B2 6/2003 Von Basse et al.
 6,700,392 B2 3/2004 Haase
 6,781,577 B2 8/2004 Shigetaka
 6,806,693 B1 10/2004 Bron
 6,825,673 B1 11/2004 Yamaoka
 6,838,887 B2 1/2005 Denen et al.
 6,859,159 B2 2/2005 Michalski
 6,882,338 B2 4/2005 Flowers
 6,888,536 B2 5/2005 Westerman et al.
 6,891,531 B2 5/2005 Lin
 6,914,547 B1 7/2005 Swaroop et al.
 6,933,873 B1 8/2005 Horsley et al.
 6,940,291 B1 9/2005 Ozick
 6,946,853 B2 9/2005 Gifford et al.
 6,958,594 B2 10/2005 Redl et al.
 6,970,120 B1 11/2005 Bjornsen
 6,970,126 B1 11/2005 O'Dowd et al.
 7,006,078 B2 2/2006 Kim
 7,031,886 B1 4/2006 Hargreaves
 7,032,051 B2 4/2006 Reay et al.
 7,046,230 B2 5/2006 Zadesky et al.
 7,068,039 B2 6/2006 Parker
 7,075,316 B2 7/2006 Umeda et al.
 7,078,916 B2 7/2006 Denison
 7,098,675 B2 8/2006 Inaba et al.
 7,129,935 B2 10/2006 Mackey
 7,148,704 B2 12/2006 Philipp
 7,158,125 B2* 1/2007 Sinclair et al. 345/173
 7,235,983 B2 6/2007 O'Dowd et al.
 7,253,643 B1 8/2007 Seguine
 7,262,609 B2 8/2007 Reynolds
 7,288,946 B2 10/2007 Hargreaves et al.
 7,301,350 B2 11/2007 Hargreaves et al.
 7,307,485 B1 12/2007 Snyder et al.
 7,339,580 B2 3/2008 Westerman et al.
 7,359,816 B2 4/2008 Kumar et al.
 7,375,535 B1 5/2008 Kutz et al.
 7,381,031 B2 6/2008 Kawaguchi et al.
 7,382,139 B2 6/2008 Mackey
 7,417,411 B2 8/2008 Hoffman et al.
 7,417,441 B2 8/2008 Reynolds
 7,423,437 B2 9/2008 Hargreaves et al.
 7,449,895 B2 11/2008 Ely et al.
 7,450,113 B2 11/2008 Gillespie et al.
 7,451,050 B2 11/2008 Hargreaves
 7,453,270 B2 11/2008 Hargreaves et al.
 7,453,279 B2 11/2008 Corbin, Jr. et al.
 7,466,307 B2* 12/2008 Trent et al. 345/173
 7,479,788 B2 1/2009 Bolender et al.
 7,495,659 B2* 2/2009 Marriott et al. 345/173
 7,499,040 B2 3/2009 Zadesky et al.
 7,521,941 B2 4/2009 Ely et al.
 7,548,073 B2 6/2009 Mackey
 7,598,822 B2 10/2009 Rajagopal et al.
 7,683,641 B2 3/2010 Hargreaves et al.
 7,821,274 B2* 10/2010 Philipp et al. 324/662
 2003/0091220 A1 5/2003 Sato et al.
 2004/0178989 A1 9/2004 Shahoian et al.
 2004/0217945 A1 11/2004 Miyamoto et al.
 2004/0239616 A1* 12/2004 Collins 345/156

2005/0031175 A1 2/2005 Hara et al.
 2005/0159126 A1 7/2005 Wang
 2006/0038793 A1 2/2006 Philipp
 2006/0097992 A1* 5/2006 Gitzinger et al. 345/173
 2006/0197750 A1 9/2006 Kerr et al.
 2006/0227117 A1* 10/2006 Proctor 345/173
 2006/0232559 A1 10/2006 Chien et al.
 2006/0262101 A1 11/2006 Layton et al.
 2007/0076897 A1 4/2007 Philipp
 2007/0247443 A1 10/2007 Philipp
 2007/0257894 A1 11/2007 Philipp
 2007/0268265 A1 11/2007 XiaoPing
 2007/0268273 A1 11/2007 Westerman et al.
 2007/0268274 A1 11/2007 Westerman et al.
 2007/0268275 A1 11/2007 Westerman et al.
 2007/0291013 A1* 12/2007 Won 345/173
 2007/0296709 A1 12/2007 GuangHai
 2008/0007534 A1* 1/2008 Peng et al. 345/173
 2008/0024455 A1 1/2008 Lee et al.
 2008/0036473 A1 2/2008 Jansson
 2008/0041639 A1 2/2008 Westerman et al.
 2008/0041640 A1 2/2008 Gillespie et al.
 2008/0042986 A1 2/2008 Westerman et al.
 2008/0042987 A1 2/2008 Westerman et al.
 2008/0042988 A1 2/2008 Westerman et al.
 2008/0042989 A1 2/2008 Westerman et al.
 2008/0042994 A1 2/2008 Westerman et al.
 2008/0068100 A1 3/2008 Goodnow et al.
 2008/0111714 A1 5/2008 Kremin
 2008/0116904 A1 5/2008 Reynolds et al.
 2008/0128182 A1 6/2008 Westerman et al.
 2008/0179112 A1* 7/2008 Qin et al. 178/18.06
 2008/0278178 A1 11/2008 Philipp

FOREIGN PATENT DOCUMENTS

GB 05/000604 B2 2/2005

OTHER PUBLICATIONS

Dennis Seguine, "Capacitive Switch Scan", Cypress Application Note AN2233a, Revision B, Apr. 14, 2005, pp. 1-6.
 Chapweske, Adam, "The PS/2 Mouse Interface", PS/2 Mouse Interfacing, 2001, 10 pages.
 Mack, Chris, "Semiconductor Lithography—The Basic Process", Gentleman Scientist, 12 pages, downloaded Apr. 20, 2006, <http://www.lithoguru.com/scientist/lithobasics.html>.
 "Photolithography", Wikipedia, the free encyclopedia, 3 pages, downloaded Apr. 20, 2006, <http://en.wikipedia.org/wiki/Photolithography>.
 "CY8C21x34 Data Sheet", Cypress Semiconductor Corporation, CSR User Module, CSR v1.0, Oct. 6, 2005, pp. 1-36.
 USPTO Final Rejection for U.S. Appl. No. 11/600,896 dated Sep. 30, 2010; 19 pages.
 USPTO Notice of Allowance for U.S. Appl. No. 11/484,085 dated Jun. 10, 2010; 4 pages.
 USPTO Final Rejection for U.S. Appl. No. 11/477,179 dated Nov. 24, 2010, 10 pages.
 USPTO Non-Final Rejection for U.S. Appl. No. 11/477,179 dated Jul. 20, 2010; 10 pages.
 USPTO Non-Final Rejection for U.S. Appl. No. 11/493,350 dated Nov. 9, 2010; 9 pages.
 USPTO Non-Final Rejection for U.S. Appl. No. 11/600,896 dated May 14, 2010; 15 pages.
 USPTO Notice of Allowance for U.S. Appl. No. 11/395,417 dated Nov. 6, 2008; 7 pages.
 USPTO Non-Final Rejection for U.S. Appl. No. 11/395,417 dated Apr. 25, 2008; 7 pages.
 USPTO Non-Final Rejection for U.S. Appl. No. 11/395,417 dated Nov. 1, 2007; 8 pages.
 USPTO Advisory Action for U.S. Appl. No. 11/395,417 dated Jul. 6, 2007; 3 pages.
 USPTO Final Rejection for U.S. Appl. No. 11/395,417 dated Apr. 24, 2007; 9 pages.
 USPTO Non-Final Rejection for U.S. Appl. No. 11/395,417 dated Oct. 26, 2006; 13 pages.

USPTO Non-Final Rejection for U.S. Appl. No. 12/367,279 dated Oct. 29, 2009; 8 pages.
The Authoritative Dictionary of IEEE Standards Terms, 2000, IEEE Press Publications, 7th Edition, pp. 1133-1134; 4 pages.
Mark Lee, "CapSense Best Practices," Cypress Semiconductor Application Note, Oct. 19, 2006; 10 pages.
USPTO Non-Final Rejection for U.S. Appl. No. 11/600,896 dated Jan. 26, 2011; 12 pages.
USPTO Notice of Allowance for U.S. Appl. No. 11/600,255 dated Jul. 27, 2010; 6 pages.
USPTO Non-Final Rejection for U.S. Appl. No. 11/600,255 dated Mar. 29, 2010; 10 pages.
USPTO Notice of Allowance for U.S. Appl. No. 11/273,708 dated Aug. 9, 2007; 4 pages.
USPTO Final Rejection for U.S. Appl. No. 11/273,708 dated Jul. 5, 2007; 8 pages.
USPTO Non-Final Rejection for U.S. Appl. No. 11/273,708 dated Mar. 19, 2007; 16 pages.
USPTO Final Rejection for U.S. Appl. No. 11/502,267 dated Feb. 3, 2009; 10 pages.
USPTO Non-Final Rejection for U.S. Appl. No. 11/502,267 dated Aug. 11, 2008; 10 pages.
USPTO Non-Final Rejection for U.S. Appl. No. 11/600,896 dated Dec. 16, 2009; 13 pages.
USPTO Notice of Allowance for U.S. Appl. No. 11/230,719 dated Jan. 16, 2008; 4 pages.
USPTO Advisory Action for U.S. Appl. No. 11/230,719 dated Nov. 30, 2007; 3 pages.
USPTO Final Rejection for U.S. Appl. No. 11/230,719 dated Sep. 7, 2007; 9 pages.
USPTO Non-Final Rejection for U.S. Appl. No. 11/230,719 dated May 25, 2007; 6 pages.
USPTO Non-Final Rejection for U.S. Appl. No. 11/230,719 dated Jan. 16, 2007; 8 pages.
USPTO Non-Final Rejection for U.S. Appl. No. 11/230,719 dated Aug. 28, 2006; 7 pages.
USPTO Non-Final Rejection for U.S. Appl. No. 11/230,719 dated May 11, 2006; 5 pages.
USPTO Non-Final Rejection for U.S. Appl. No. 11/484,085 dated Sep. 17, 2009; 8 pages.
USPTO Final Rejection for U.S. Appl. No. 11/484,085 dated Mar. 16, 2010; 7 pages.

USPTO Final Rejection for U.S. Appl. No. 11/477,179 dated Apr. 1, 2010; 10 pages.
USPTO Non-Final Rejection for U.S. Appl. No. 11/477,179 dated Nov. 18, 2009; 10 pages.
USPTO Non-Final Rejection for U.S. Appl. No. 11/477,179 dated Jun. 9, 2009; 13 pages.
U.S. Appl. No. 11/493,350 (CD06097): "Technique for Increasing the Sensitivity of Capacitive Sensor Arrays," Lee et al., filed on Jul. 25, 2006; 48 pages.
USPTO Notice of Allowance for U.S. Appl. No. 11/489,944 dated Apr. 9, 2007; 7 pages.
USPTO Non-Final Rejection for U.S. Appl. No. 11/700,314 dated Mar. 26, 2010; 7 pages.
"The Virtual Keyboard: I-Tech Bluetooth/Serial Virtual Laser Keyboard Available Now!" The Virtual Laser Keyboard (VKB) Online Worldwide Shop, <<http://www.virtual-laser-keyboard.com>> downloaded Apr. 13, 2006; 4 pages.
Wikipedia, The Free Encyclopedia, "IBM PC Keyboard," <http://en.wikipedia.org/wiki/PC_keyboard> accessed May 19, 2006; 3 pages.
USPTO Non-Final Rejection for U.S. Appl. No. 11/600,896 dated May 14, 2010; 15 pages.
USPTO Notice of Allowance for U.S. Appl. No. 11/489,944 dated May 24, 2007; 2 pages.
USPTO Notice of Allowance for U.S. Appl. No. 11/489,944 dated Apr. 9, 2007; 7 pages.
USPTO Advisory Action for U.S. Appl. No. 11/477,179 dated Jun. 7, 2010; 3 pages.
USPTO Non-Final Rejection for U.S. Appl. No. 11/477,179 dated Jul. 20, 2010; 10 pages.
USPTO Notice of Allowance for U.S. Appl. No. 12/367,279 dated Aug. 23, 2010; 7 pages.
USPTO Non-Final Rejection for U.S. Appl. No. 11/493,350 dated Jun. 16, 2010; 8 pages.
USPTO Notice of Allowance for U.S. Appl. No. 11/700,314 dated Sep. 16, 2010; 8 pages.
USPTO Final Rejection for U.S. Appl. No. 12/367,279 dated Apr. 1, 2010; 6 pages.
USPTO Advisory Action for U.S. Appl. No. 12/367,279 dated Jun. 25, 2010; 3 pages.
USPTO Non-Final Rejection for U.S. Appl. No. 11/442,212 dated Feb. 25, 2011; 13 pages.

* cited by examiner

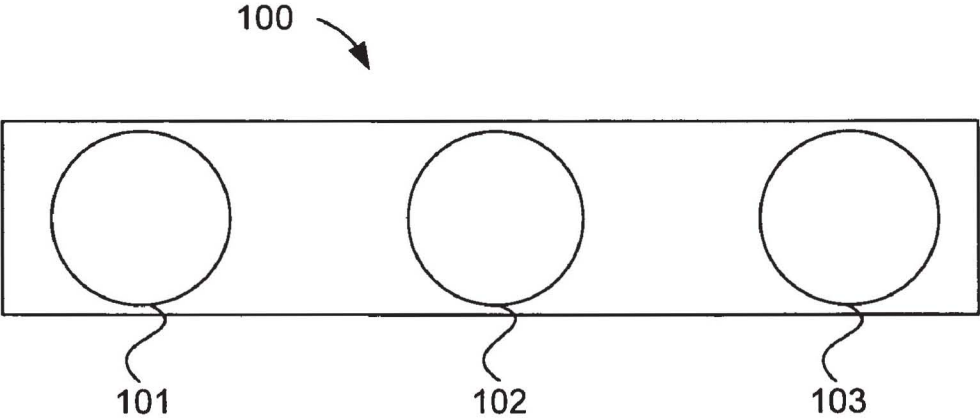

FIG. 1A

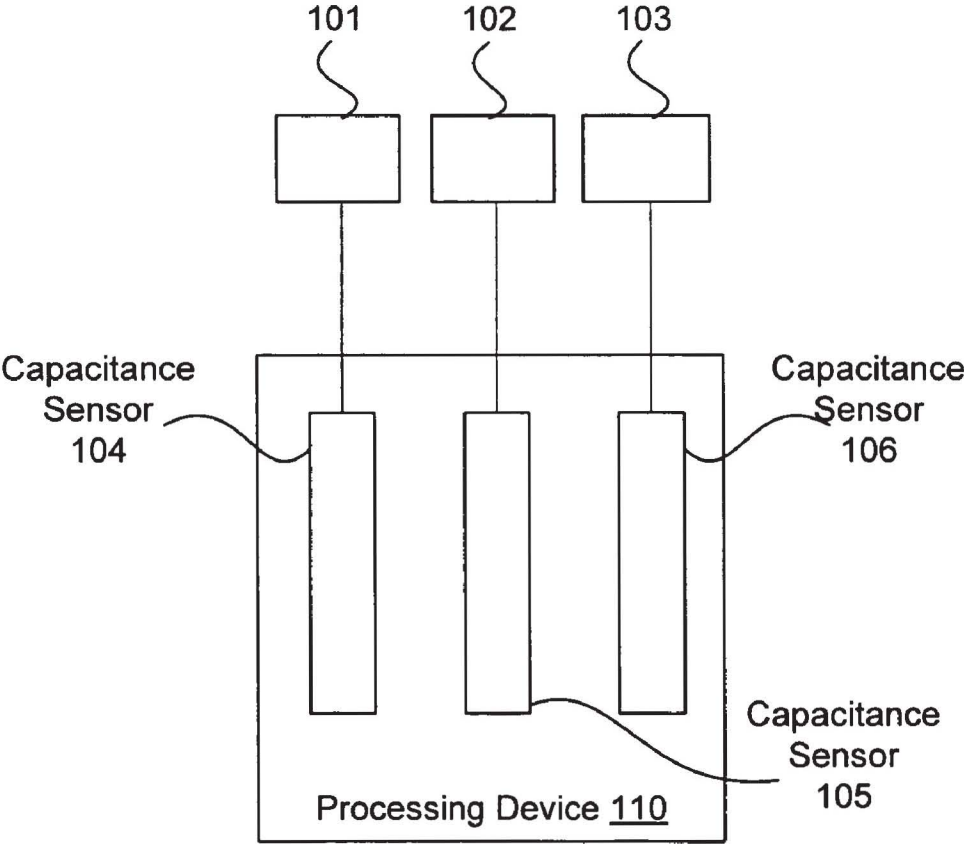

FIG. 1B

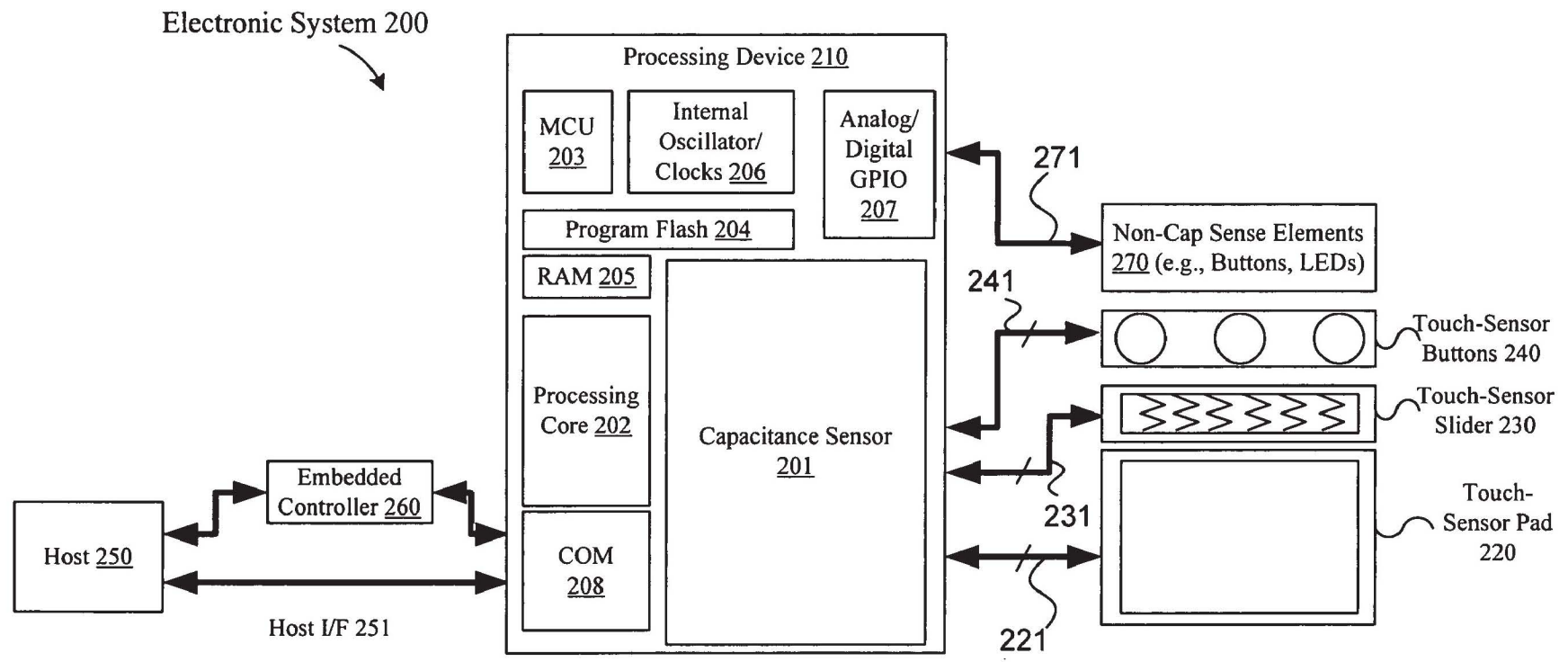

FIG. 2

300 ↘

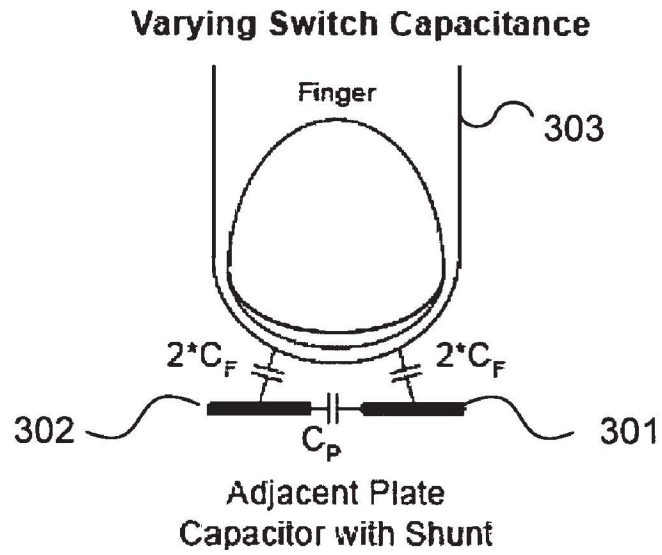

FIG. 3A

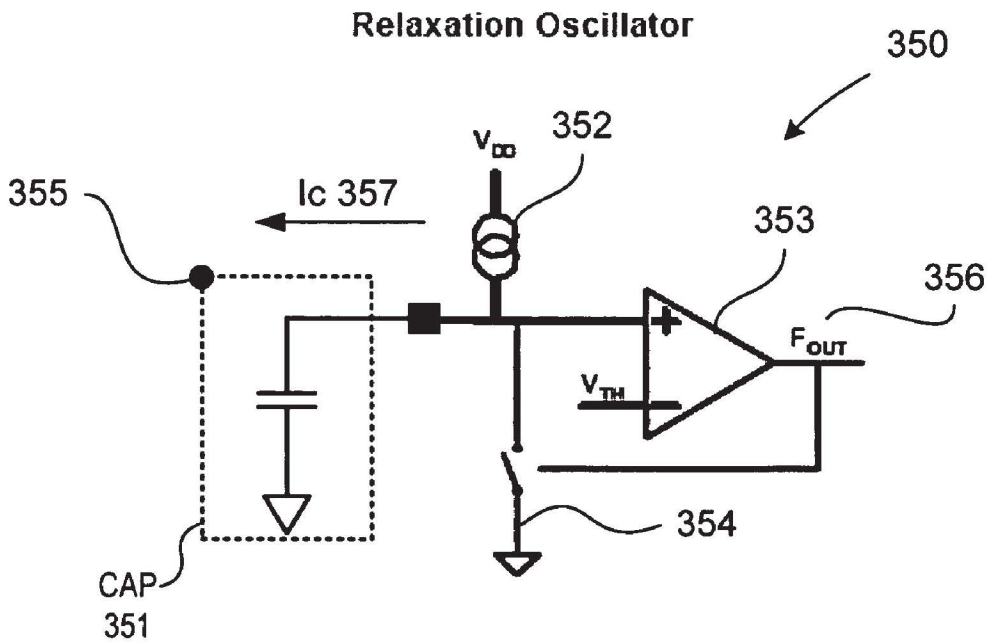

FIG. 3B

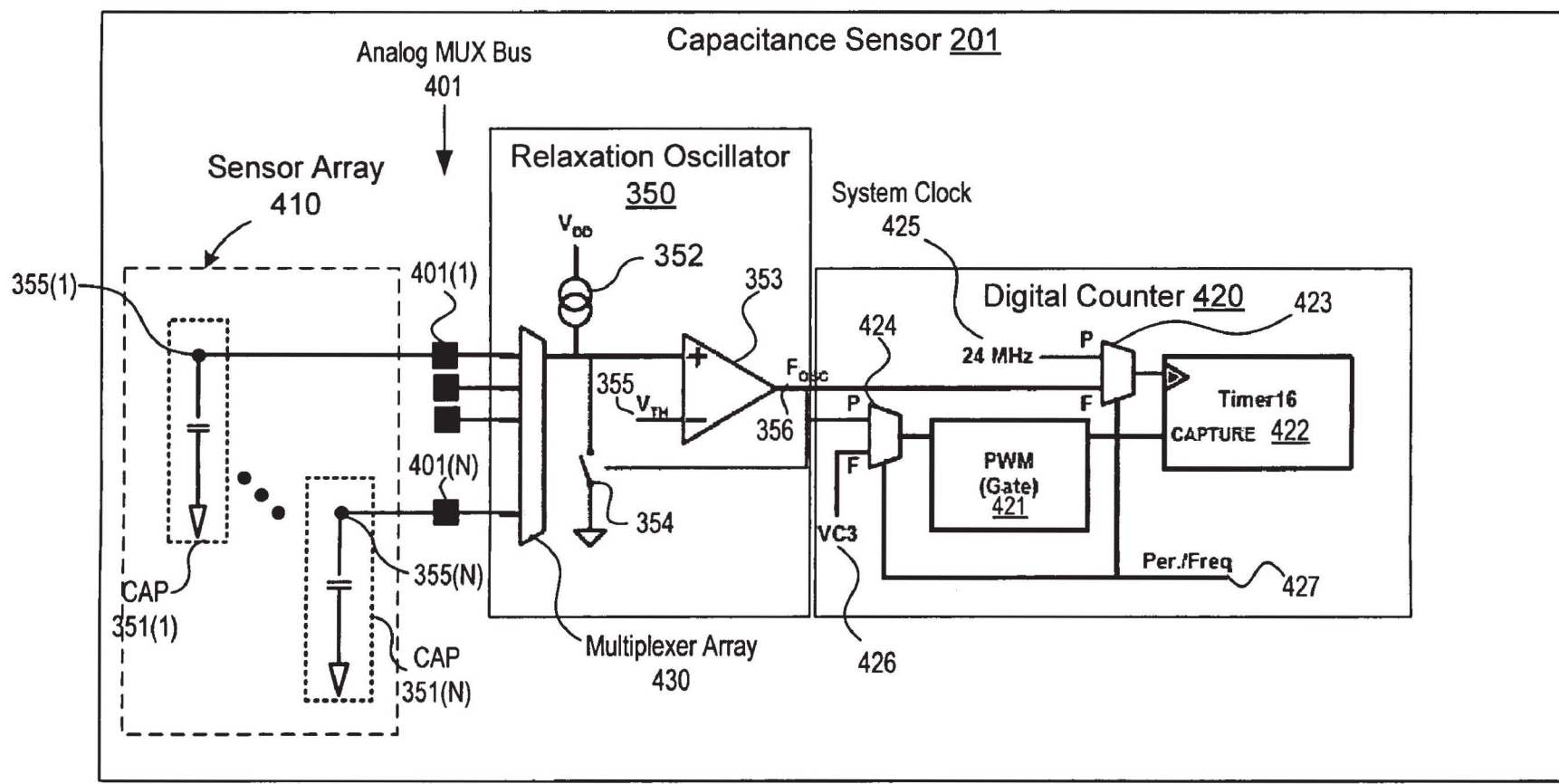

FIG. 4

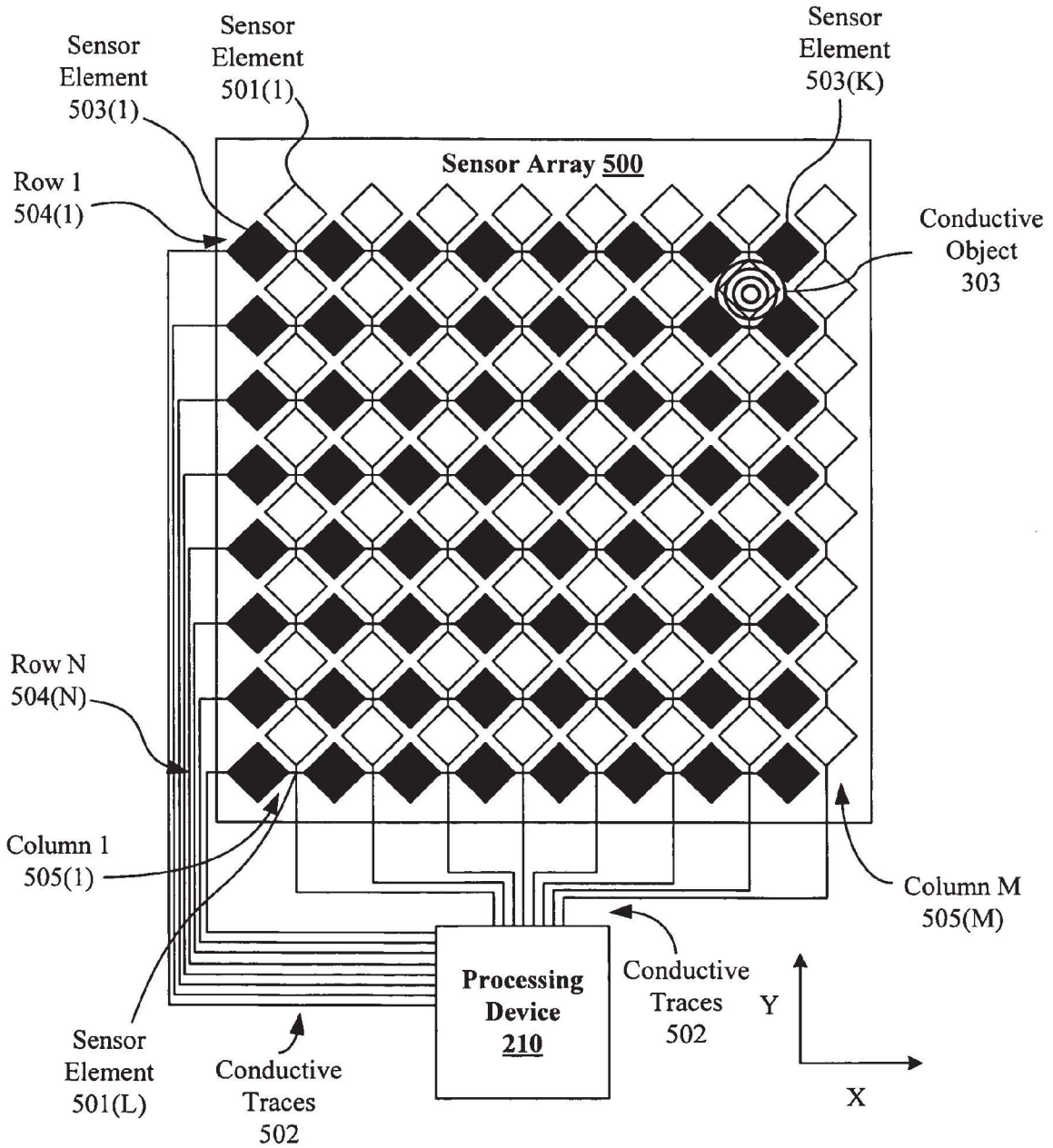

FIG. 5A

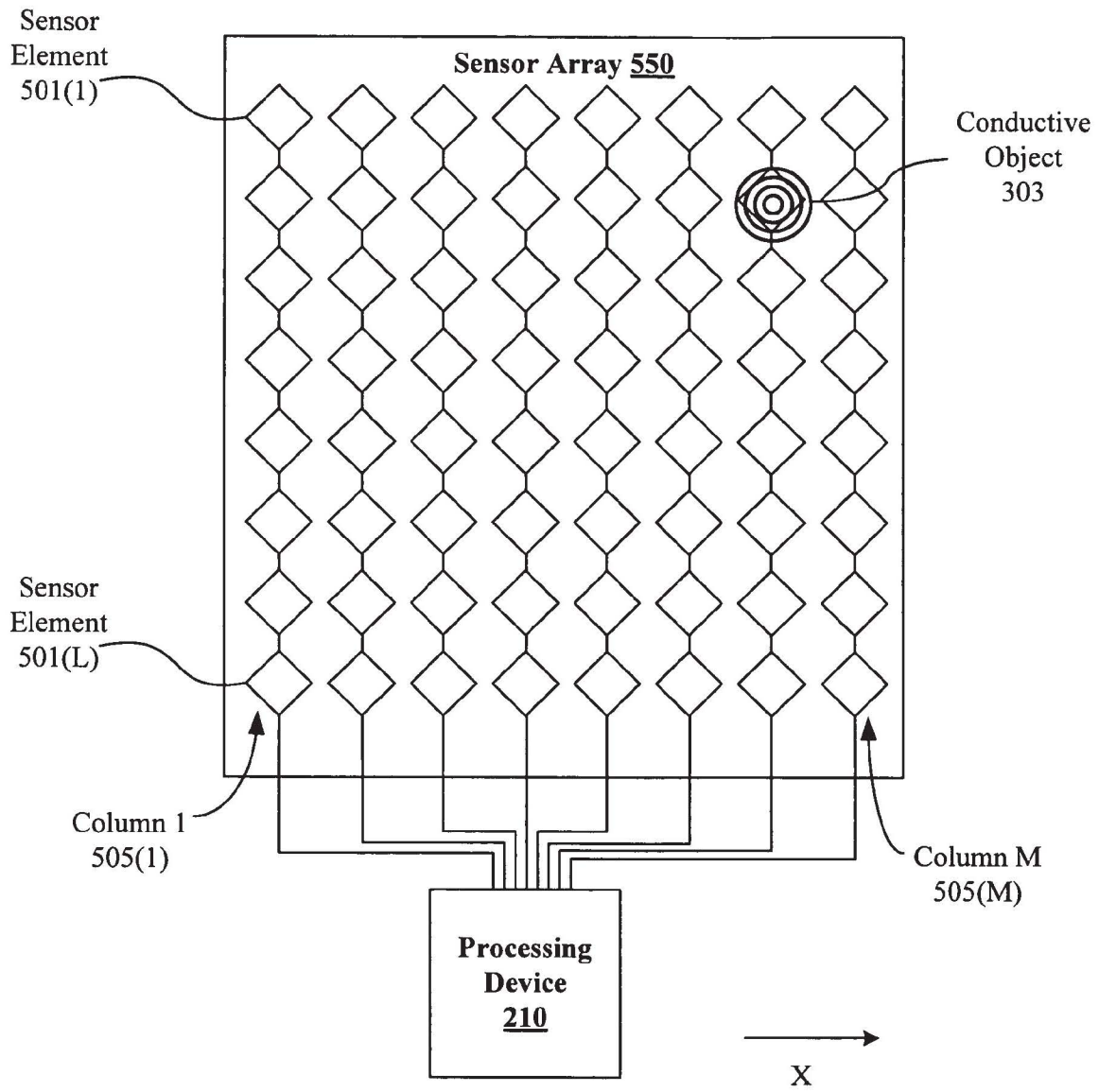

FIG. 5B

TOP-VIEW of 2-Layer Touch-Sensor Pad 220

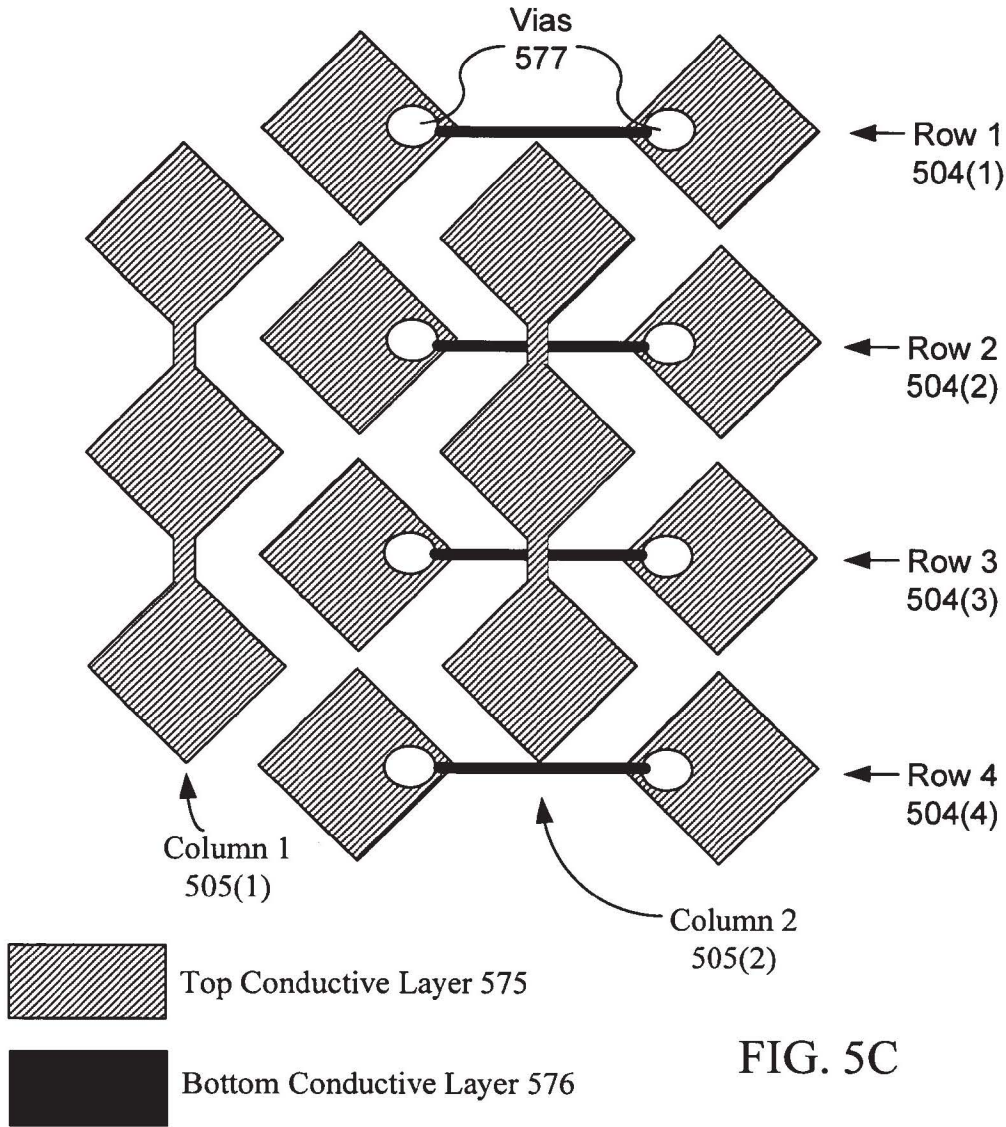

FIG. 5C

CROSS-SECTIONAL VIEW of 2-Layer Touch-Sensor Pad 220

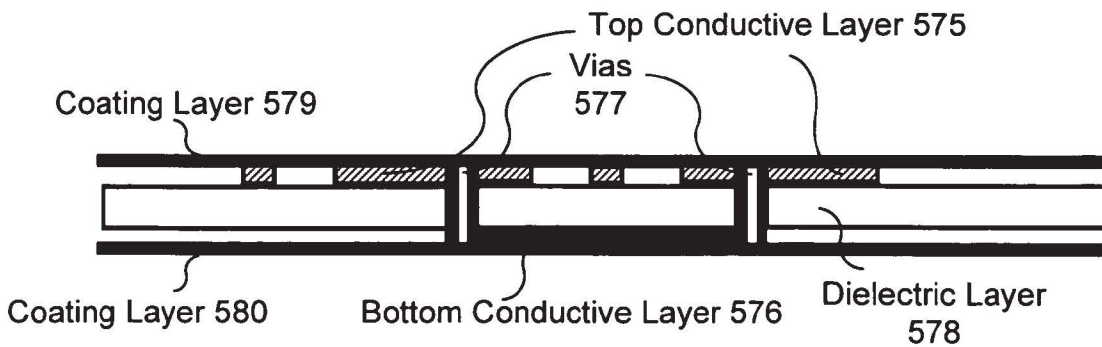

FIG. 5D

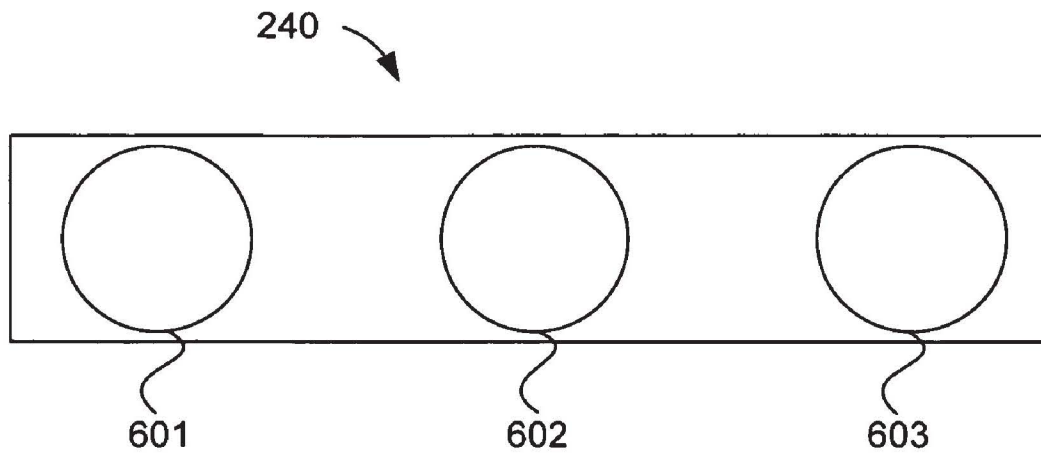

FIG. 6A

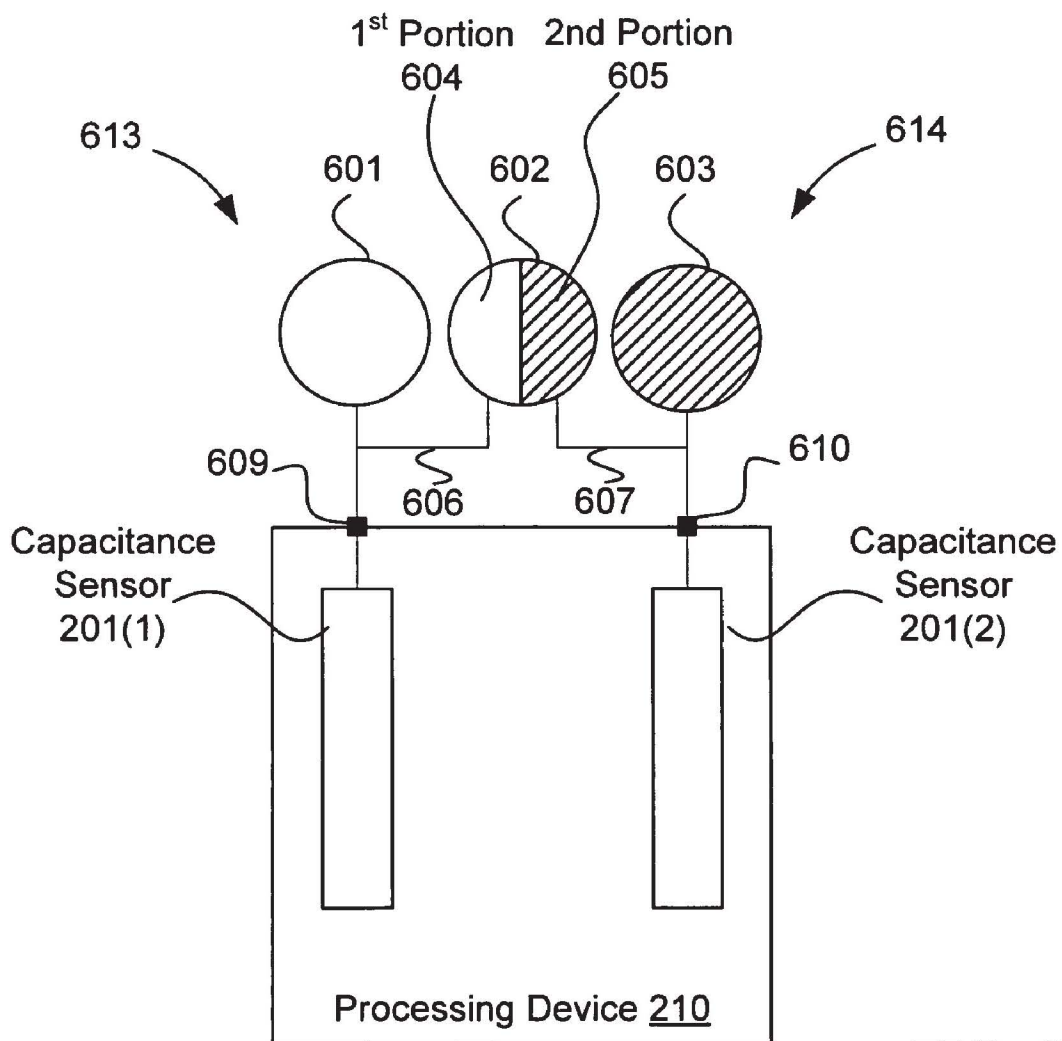
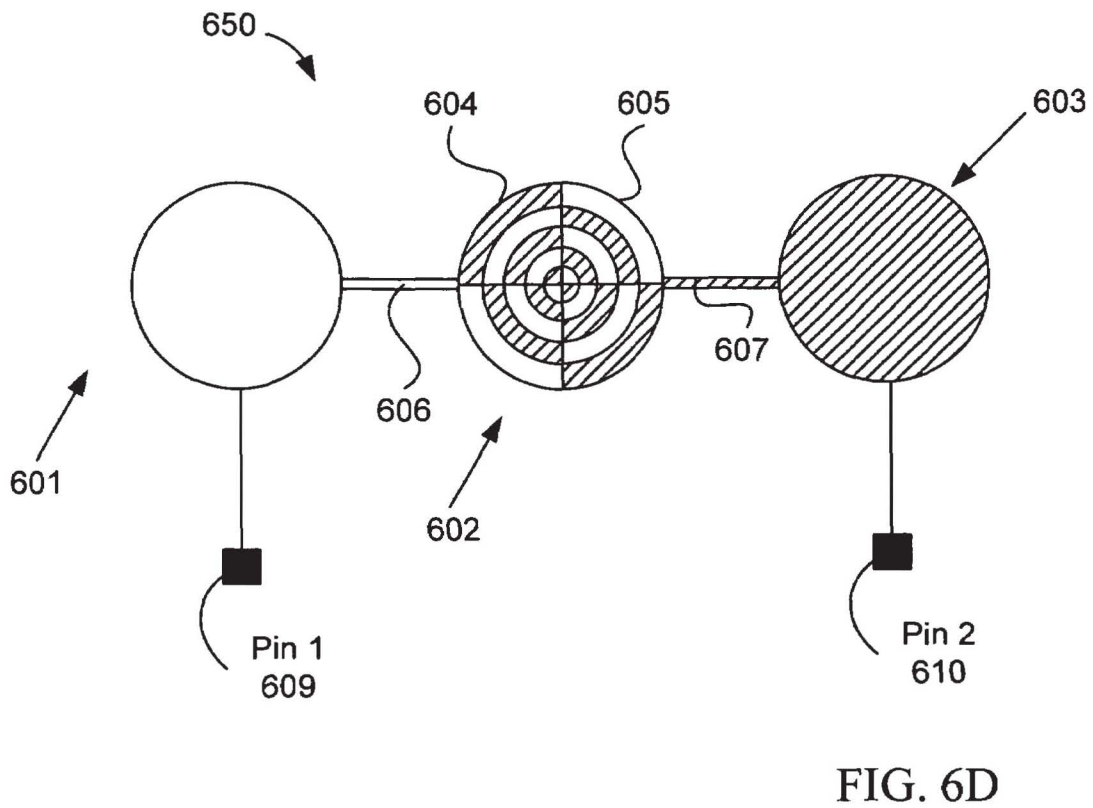
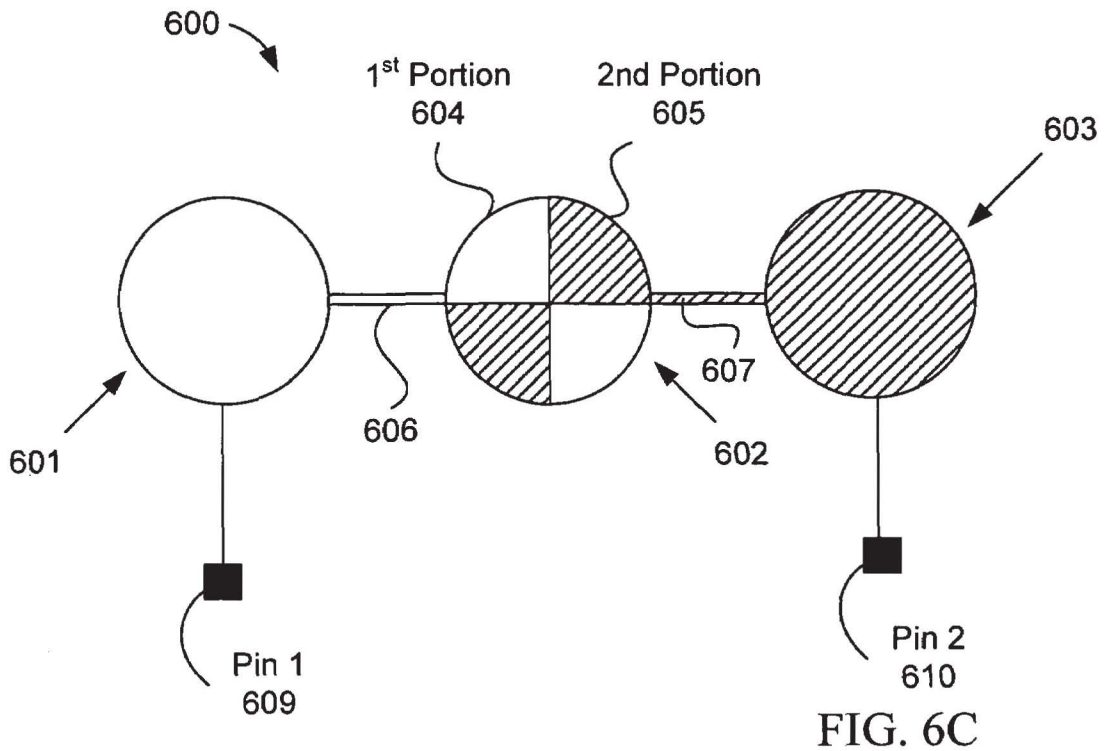

FIG. 6B



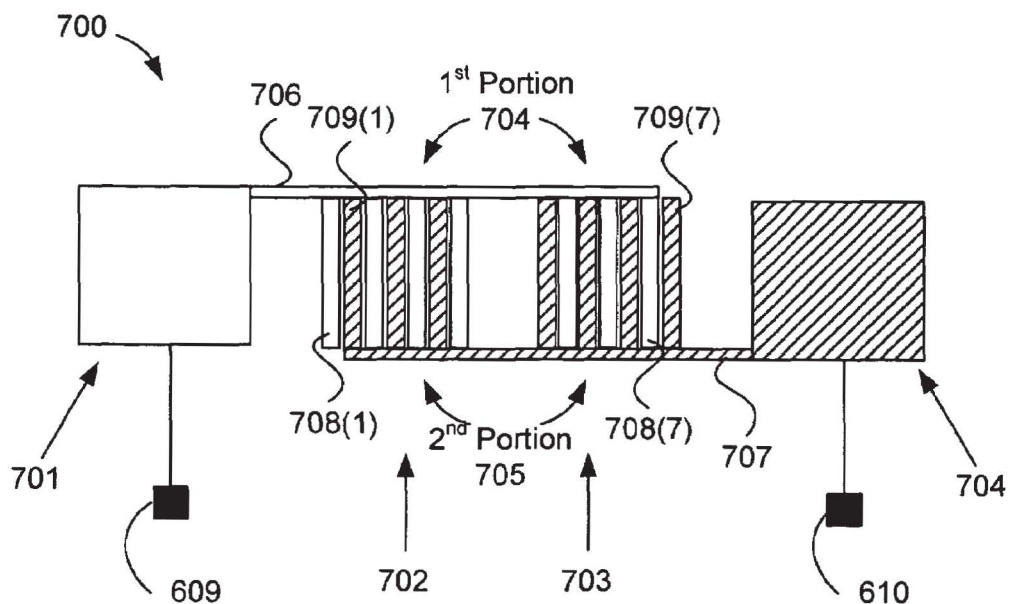

FIG. 7A

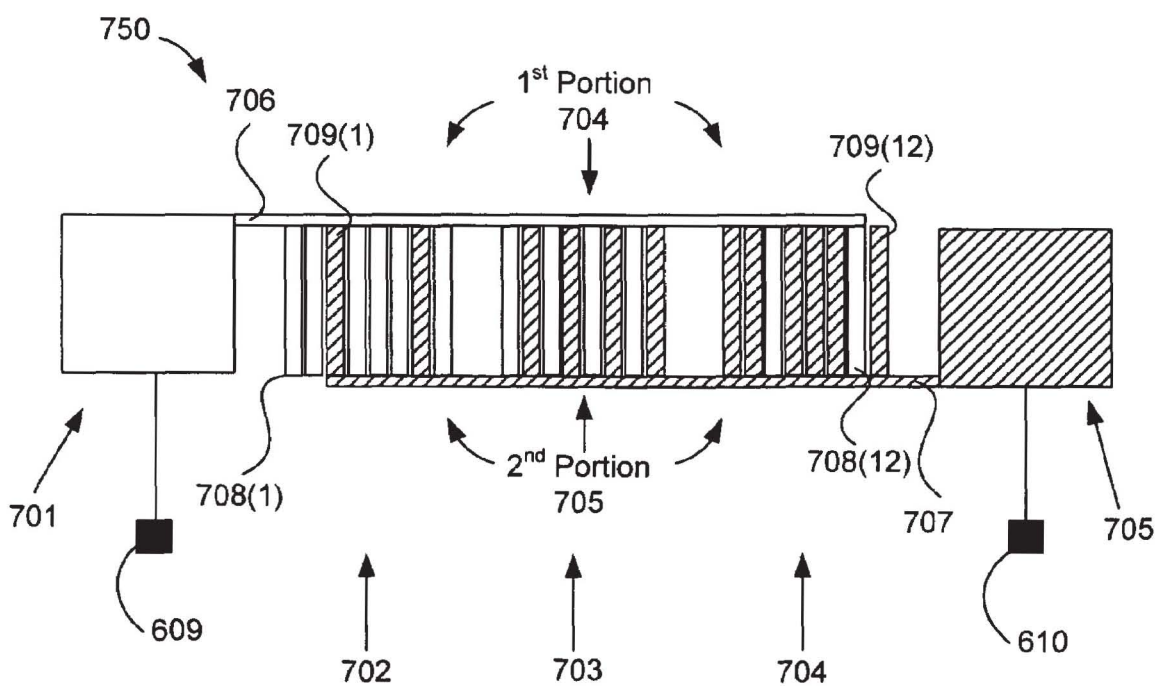

FIG. 7B

1

TWO-PIN BUTTONS

TECHNICAL FIELD

This invention relates to the field of user interface devices and, in particular, to touch-sensing devices.

BACKGROUND

Computing devices, such as notebook computers, personal data assistants (PDAs), and mobile handsets, have user interface devices, which are also known as human interface device (HID). One user interface device that is common is a touch-sensor button. A basis touch-sensor button emulates the function of a mechanical button. Touch-sensor buttons may be embedded into different types of operational panels of electronic devices. For example, touch-sensor buttons may be used on operational or control panels of household appliances, consumer electronics, mechanical devices, and the like. Touch-sensor buttons may also be used in conjunction with, or in place of, other user input devices, such as keyboards, mice, trackballs, or the like.

FIG. 1A illustrates a conventional sensing device having three touch-sensor buttons. Conventional sensing device 100 includes button 101, button 102, and button 103. These buttons are conventional touch-sensor buttons. These three buttons may be used for user input using a conductive object, such as a finger.

FIG. 1B illustrates a conventional sensing device of three touch-sensor buttons 101-103 coupled to a processing device 110. Processing device 110 is used to detect whether a conductive object is present on either, or none, of the touch-sensor buttons 101-103. To detect the presence of the conductive object, the processing device 110 may include capacitance sensors 104-106, which are coupled to buttons 101-103, respectively. The capacitance sensors of the processing device are coupled to the touch-sensor buttons in a one-to-one configuration. Accordingly, the processing device 110 scans the touch-sensor buttons 101-103 using the capacitance sensors 104-106, and measures the capacitance on the touch-sensor buttons 101-103.

Each of the conventional touch-sensor buttons 101-103 may be made of a sensor element of conductive material, such as copper-clad. The conductive material may be form shaped in a circular shape (illustrated in FIG. 1A), or even in a rectangular shape (illustrated in FIG. 1B). The touch-sensor buttons may be capacitance sensor buttons, which may be used as non-contact switches. These switches, when protected by an insulating layer, offer resistance to severe environments.

It should be noted that the conventional configuration of FIG. 1B includes a one-to-one configuration of touch-sensor buttons to capacitance sensors. There are other conventional configurations that may use less capacitance sensors to measure the capacitance on the three touch-sensor buttons. These conventional configurations, however, still require a one-to-one configuration of pins to touch-sensor buttons. Accordingly, by adding more buttons, the processing device needs to have more pins to correspond to the one-to-one configuration of pins to touch-sensor buttons. Similarly, by increasing the pin count, the scan time to scan the sensor elements increases. In addition, the memory of the processing device, which may be used to store program data and/or temporary data (e.g., raw measurement data, differential counts, baseline measurement data, and the like), increases by increasing the pin count.

2

BRIEF DESCRIPTION OF THE DRAWINGS

The present invention is illustrated by way of example, and not by way of limitation, in the figures of the accompanying drawings.

FIG. 1A illustrates a conventional sensing device having three touch-sensor buttons.

FIG. 1B illustrates a conventional sensing device of three touch-sensor buttons coupled to a processing device.

FIG. 2 illustrates a block diagram of one embodiment of an electronic system having a processing device for detecting a presence of a conductive object.

FIG. 3A illustrates a varying switch capacitance.

FIG. 3B illustrates one embodiment of a relaxation oscillator.

FIG. 4 illustrates a block diagram of one embodiment of a capacitance sensor including a relaxation oscillator and digital counter.

FIG. 5A illustrates a top-side view of one embodiment of a sensor array having a plurality of sensor elements for detecting a presence of a conductive object on the sensor array of a touch-sensor pad.

FIG. 5B illustrates a top-side view of one embodiment of a sensor array having a plurality of sensor elements for detecting a presence of a conductive object on the sensor array of a touch-sensor slider

FIG. 5C illustrates a top-side view of one embodiment of a two-layer touch-sensor pad.

FIG. 5D illustrates a side view of one embodiment of the two-layer touch-sensor pad of FIG. 5C.

FIG. 6A illustrates one embodiment of a sensing device having three touch-sensor buttons.

FIG. 6B illustrates one embodiment of the sensing device of FIG. 6A coupled to a processing device.

FIG. 6C illustrates another embodiment of a sensing device having three touch-sensor buttons.

FIG. 6D illustrates another embodiment of a sensing device having three touch-sensor buttons.

FIG. 7A illustrates another embodiment of a sensing device having four touch-sensor buttons.

FIG. 7B illustrates another embodiment of a sensing device having five touch-sensor buttons.

DETAILED DESCRIPTION

Described herein is an apparatus and method for detecting a presence of a conductive object on a sensing device, and recognizing three or more button operations performed by the conductive object using two sensing areas of the sensing device. The following description sets forth numerous specific details such as examples of specific systems, components, methods, and so forth, in order to provide a good understanding of several embodiments of the present invention. It will be apparent to one skilled in the art, however, that at least some embodiments of the present invention may be practiced without these specific details. In other instances, well-known components or methods are not described in detail or are presented in simple block diagram format in order to avoid unnecessarily obscuring the present invention. Thus, the specific details set forth are merely exemplary. Particular implementations may vary from these exemplary details and still be contemplated to be within the spirit and scope of the present invention.

Embodiments of a method and apparatus are described to recognize three or more button operations performed by the conductive object on three or more sensor elements that are coupled to two pins of a processing device. In one embodi-

ment, the apparatus may include a sensing device (e.g., touch-sensor button) that has first, second, and third sensor elements. The third sensor element has a first portion coupled to the first sensor element, and a second portion coupled to the second sensor element. These portions of the third sensor element are electrically isolated from one another.

The embodiments describe herein permit the expansion of additional buttons (e.g., three or more total buttons) to the sensing device, while using only two pins on the processing device. Conversely, since the conventional configuration has implemented a one-to-one configuration of sensor elements to pins of the processing device, each button added requires an additional pin on the processing device. Using only two pins, the scan time does not increase by adding additional buttons to implement three or more buttons on the sensing device. By maintaining two pins for three or more buttons, the scan time to scan the sensor elements is not increased. In other words, more buttons may be implemented without increasing the total scan time of the sensing device. Similarly, the memory of the processing device is not increased to accommodate additional program data and/or temporary data (e.g., raw measurement data, differential counts, baseline measurement data, and the like) for the additional buttons.

The sensing device may use two capacitive switch relaxation oscillator (CSR) pins of a processing device to realize more than two buttons on the sensing device. For example, the three or more buttons may be realized by using two sensing areas. Each sensing area may include a bar of conductive material and several interconnected sub-bars. The sub-bars of the two sensing areas are interleaved and are electrically isolated. In other words, one set of interconnected sub-bars are connected to one pin, while the other set is coupled to the other pin. The two sensing areas make up three or more sensor elements that are used to form the touch-sensor buttons. The different buttons contain different percentages of surface area of the sensing areas. Alternatively, each sensing area may include two or more bars of conductive material with or without several interconnected sub-bars.

For example, a three-button scheme using two pins includes one sensor element that has 100% of the first sensing area, the second sensor element has 50% of the first sensing area and 50% of the second sensing area, and the third sensor element has 100% of the second sensing area. Accordingly, by scanning and measuring the capacitance (e.g., capacitance variation of the capacitance minus the baseline, as described below) on the two pins to detect the presence of the conductive object, the processing device can distinguish between the presence of the conductive object on the first, second, and third sensor elements. For example, if the capacitance variation δ_1 , measured on the first pin, is greater than zero, and the capacitance variation δ_2 , measured on the second pin is equal to approximately zero, then the first button has been pressed. Similarly, if the capacitance variation δ_1 , measured on the first pin, is equal to the capacitance variation δ_2 , measured on the second pin, then the second button has been pressed. If the capacitance variation δ_1 , measured on the first pin, is equal to approximately zero, and the capacitance variation δ_2 , measured on the second pin is greater than zero, then the third button has been pressed.

The embodiments herein may be beneficial to help reduce the pin count of the processing device. This may decrease the complexity of the processing device, or allow the processing device to support additional functionality, such as cursor positioning and selecting functionality, keyboard functionality, slider functionality, or the like. Furthermore, the embodiments may be beneficial to help reduce the scan time of the sensing device. Using two pins of the processing device to

measure the capacitance on two sensing areas to realize three or more buttons is faster than measuring the capacitance on three or more touch-sensor buttons of the conventional configuration (e.g., one-to-one configuration). In addition, using two pins reduces the RAM/FLASH space needed in the sensing device, as compared to the conventional configuration.

The embodiments described herein may be used in different types of operational panels of electronic devices. For example, touch-sensor buttons may be used on operational or control panels of household appliances, consumer electronics, mechanical devices, and the like. Touch-sensor buttons may also be used in conjunction with, or in place of, other user input devices, such as keyboards, mice, trackballs, or the like.

FIG. 2 illustrates a block diagram of one embodiment of an electronic system having a processing device for detecting a presence of a conductive object. Electronic system 200 includes processing device 210, touch-sensor pad 220, touch-sensor slider 230, touch-sensor buttons 240, host processor 250, embedded controller 260, and non-capacitance sensor elements 270. The processing device 210 may include analog and/or digital general purpose input/output (“GPIO”) ports 207. GPIO ports 207 may be programmable. GPIO ports 207 may be coupled to a Programmable Interconnect and Logic (“PIL”), which acts as an interconnect between GPIO ports 207 and a digital block array of the processing device 210 (not illustrated). The digital block array may be configured to implement a variety of digital logic circuits (e.g., DAC, digital filters, digital control systems, etc.) using, in one embodiment, configurable user modules (“UMs”). The digital block array may be coupled to a system bus. Processing device 210 may also include memory, such as random access memory (RAM) 205 and program flash 204. RAM 205 may be static RAM (SRAM), and program flash 204 may be a non-volatile storage, which may be used to store firmware (e.g., control algorithms executable by processing core 202 to implement operations described herein). Processing device 210 may also include a memory controller unit (MCU) 203 coupled to memory and the processing core 202.

The processing device 210 may also include an analog block array (not illustrated). The analog block array is also coupled to the system bus. Analog block array also may be configured to implement a variety of analog circuits (e.g., ADC, analog filters, etc.) using, in one embodiment, configurable UMs. The analog block array may also be coupled to the GPIO 207.

As illustrated, capacitance sensor 201 may be integrated into processing device 210. Capacitance sensor 201 may include analog I/O for coupling to an external component, such as touch-sensor pad 220, touch-sensor slider 230, touch-sensor buttons 240, and/or other devices. Capacitance sensor 201 and processing device 202 are described in more detail below.

It should be noted that the embodiments described herein are not limited to touch-sensor pads for notebook implementations, but can be used in other capacitive sensing implementations, for example, the sensing device may be a touch-sensor slider 230, or a touch-sensor button 240 (e.g., capacitance sensing button). Similarly, the operations described herein are not limited to notebook cursor operations, but can include other operations, such as lighting control (dimmer), volume control, graphic equalizer control, speed control, or other control operations requiring gradual adjustments. It should also be noted that these embodiments of capacitive sensing implementations may be used in conjunction with non-capacitive sensing elements, including but not limited to pick buttons, sliders (ex. display brightness and

5

contrast), scroll-wheels, multi-media control (ex. volume, track advance, etc) handwriting recognition and numeric key-pad operation.

In one embodiment, the electronic system **200** includes a touch-sensor pad **220** coupled to the processing device **210** via bus **221**. Touch-sensor pad **220** may include a multi-dimension sensor array. The multi-dimension sensor array comprises a plurality of sensor elements, organized as rows and columns. In another embodiment, the electronic system **200** includes a touch-sensor slider **230** coupled to the processing device **210** via bus **231**. Touch-sensor slider **230** may include a single-dimension sensor array. The single-dimension sensor array comprises a plurality of sensor elements, organized as rows, or alternatively, as columns. In another embodiment, the electronic system **200** includes a touch-sensor button **240** coupled to the processing device **210** via bus **241**. Touch-sensor button **240** may include a single-dimension or multi-dimension sensor array. The single- or multi-dimension sensor array comprises a plurality of sensor elements. For a touch-sensor button, the plurality of sensor elements may be coupled together to detect a presence of a conductive object over the entire surface of the sensing device. Alternatively, the touch-sensor button **240** has a single sensor element to detect the presence of the conductive object. In one embodiment, the touch-sensor button **240** may be a capacitance sensor element. Capacitance sensor elements may be used as non-contact switches. These switches, when protected by an insulating layer, offer resistance to severe environments.

The electronic system **200** may include any combination of one or more of the touch-sensor pad **220**, touch-sensor slider **230**, and/or touch-sensor button **240**. In another embodiment, the electronic system **200** may also include non-capacitance sensor elements **270** coupled to the processing device **210** via bus **271**. The non-capacitance sensor elements **270** may include buttons, light emitting diodes (LEDs), and other user interface devices, such as a mouse, a keyboard, or other functional keys that do not require capacitance sensing. In one embodiment, buses **271**, **241**, **231**, and **221** may be a single bus. Alternatively, these buses may be configured into any combination of one or more separate buses.

The processing device may also provide value-added functionality such as keyboard control integration, LEDs, battery charger and general purpose I/O, as illustrated as non-capacitance sensor elements **270**. Non-capacitance sensor elements **270** are coupled to the GPIO **207**.

Processing device **210** may include internal oscillator/clocks **206** and communication block **208**. The oscillator/clocks block **206** provides clock signals to one or more of the components of processing device **210**. Communication block **208** may be used to communicate with an external component, such as a host processor **250**, via host interface (I/F) line **251**. Alternatively, processing block **210** may also be coupled to embedded controller **260** to communicate with the external components, such as host **250**. Interfacing to the host **250** can be through various methods. In one exemplary embodiment, interfacing with the host **250** may be done using a standard PS/2 interface to connect to an embedded controller **260**, which in turn sends data to the host **250** via low pin count (LPC) interface. In some instances, it may be beneficial for the processing device **210** to do both touch-sensor pad and keyboard control operations, thereby freeing up the embedded controller **260** for other housekeeping functions. In another exemplary embodiment, interfacing may be done using a universal serial bus (USB) interface directly coupled to the host **250** via host interface line **251**. Alternatively, the processing device **210** may communicate to external compo-

6

nents, such as the host **250** using industry standard interfaces, such as USB, PS/2, inter-integrated circuit (I2C) bus, or system packet interfaces (SPI). The host **250** and/or embedded controller **260** may be coupled to the processing device **210** with a ribbon or flex cable from an assembly, which houses the sensing device and processing device.

In one embodiment, the processing device **210** is configured to communicate with the embedded controller **260** or the host **250** to send and/or receive data. The data may be a command or alternatively a signal. In an exemplary embodiment, the electronic system **200** may operate in both standard-mouse compatible and enhanced modes. The standard-mouse compatible mode utilizes the HID class drivers already built into the Operating System (OS) software of host **250**. These drivers enable the processing device **210** and sensing device to operate as a standard cursor control user interface device, such as a two-button PS/2 mouse. The enhanced mode may enable additional features such as scrolling (reporting absolute position) or disabling the sensing device, such as when a mouse is plugged into the notebook. Alternatively, the processing device **210** may be configured to communicate with the embedded controller **260** or the host **250**, using non-OS drivers, such as dedicated touch-sensor pad drivers, or other drivers known by those of ordinary skill in the art.

In other words, the processing device **210** may operate to communicate data (e.g., commands or signals) using hardware, software, and/or firmware, and the data may be communicated directly to the processing device of the host **250**, such as a host processor, or alternatively, may be communicated to the host **250** via drivers of the host **250**, such as OS drivers, or other non-OS drivers. It should also be noted that the host **250** may directly communicate with the processing device **210** via host interface **251**.

In one embodiment, the data sent to the host **250** from the processing device **210** includes click, double-click, movement of the cursor, scroll-up, scroll-down, scroll-left, scroll-right, step Back, and step Forward. Alternatively, other user interface device commands may be communicated to the host **250** from the processing device **210**. These commands may be based on gestures occurring on the sensing device that are recognized by the processing device, such as tap, push, hop, and zigzag gestures. Alternatively, other commands may be recognized. Similarly, signals may be sent that indicate the recognition of these operations.

In particular, a tap gesture, for example, may be when the finger (e.g., conductive object) is on the sensing device for less than a threshold time. If the time the finger is placed on the touchpad is greater than the threshold time it may be considered to be a movement of the cursor, in the x- or y-axes. Scroll-up, scroll-down, scroll-left, and scroll-right, step back, and step-forward may be detected when the absolute position of the conductive object is within a pre-defined area, and movement of the conductive object is detected.

Processing device **210** may reside on a common carrier substrate such as, for example, an integrated circuit (IC) die substrate, a multi-chip module substrate, or the like. Alternatively, the components of processing device **210** may be one or more separate integrated circuits and/or discrete components. In one exemplary embodiment, processing device **210** may be a Programmable System on a Chip (PSoC™) processing device, manufactured by Cypress Semiconductor Corporation, San Jose, Calif. Alternatively, processing device **210** may be one or more other processing devices known by those of ordinary skill in the art, such as a microprocessor or central processing unit, a controller, special-purpose processor, digital signal processor (DSP), an application specific integrated circuit (ASIC), a field programmable gate array

(FPGA), or the like. In an alternative embodiment, for example, the processing device may be a network processor having multiple processors including a core unit and multiple microengines. Additionally, the processing device may include any combination of general-purpose processing device(s) and special-purpose processing device(s).

Capacitance sensor **201** may be integrated into the IC of the processing device **210**, or alternatively, in a separate IC. Alternatively, descriptions of capacitance sensor **201** may be generated and compiled for incorporation into other integrated circuits. For example, behavioral level code describing capacitance sensor **201**, or portions thereof, may be generated using a hardware descriptive language, such as VHDL or Verilog, and stored to a machine-accessible medium (e.g., CD-ROM, hard disk, floppy disk, etc.). Furthermore, the behavioral level code can be compiled into register transfer level ("RTL") code, a netlist, or even a circuit layout and stored to a machine-accessible medium. The behavioral level code, the RTL code, the netlist, and the circuit layout all represent various levels of abstraction to describe capacitance sensor **201**.

It should be noted that the components of electronic system **200** may include all the components described above. Alternatively, electronic system **200** may include only some of the components described above.

In one embodiment, electronic system **200** may be used in a notebook computer. Alternatively, the electronic device may be used in other applications, such as a mobile handset, a personal data assistant (PDA), a keyboard, a television, a remote control, a monitor, a handheld multi-media device, a handheld video player, a handheld gaming device, or a control panel.

In one embodiment, capacitance sensor **201** may be a capacitive switch relaxation oscillator (CSR). The CSR may have an array of capacitive touch switches using a current-programmable relaxation oscillator, an analog multiplexer, digital counting functions, and high-level software routines to compensate for environmental and physical switch variations. The switch array may include combinations of independent switches, sliding switches (e.g., touch-sensor slider), and touch-sensor pads implemented as a pair of orthogonal sliding switches. The CSR may include physical, electrical, and software components. The physical component may include the physical switch itself, typically a pattern constructed on a printed circuit board (PCB) with an insulating cover, a flexible membrane, or a transparent overlay. The electrical component may include an oscillator or other means to convert a changed capacitance into a measured signal. The electrical component may also include a counter or timer to measure the oscillator output. The software component may include detection and compensation software algorithms to convert the count value into a switch detection decision. For example, in the case of slide switches or X-Y touch-sensor pads, a calculation for finding position of the conductive object to greater resolution than the physical pitch of the switches may be used.

It should be noted that there are various known methods for measuring capacitance. Although the embodiments described herein are described using a relaxation oscillator, the present embodiments are not limited to using relaxation oscillators, but may include other methods, such as current versus voltage phase shift measurement, resistor-capacitor charge timing, capacitive bridge divider, charge transfer, or the like.

The current versus voltage phase shift measurement may include driving the capacitance through a fixed-value resistor to yield voltage and current waveforms that are out of phase by a predictable amount. The drive frequency can be adjusted

to keep the phase measurement in a readily measured range. The resistor-capacitor charge timing may include charging the capacitor through a fixed resistor and measuring timing on the voltage ramp. Small capacitor values may require very large resistors for reasonable timing. The capacitive bridge divider may include driving the capacitor under test through a fixed reference capacitor. The reference capacitor and the capacitor under test form a voltage divider. The voltage signal is recovered with a synchronous demodulator, which may be done in the processing device **210**. The charge transfer may be conceptually similar to an R-C charging circuit. In this method, C_P is the capacitance being sensed. C_{SUM} is the summing capacitor, into which charge is transferred on successive cycles. At the start of the measurement cycle, the voltage on C_{SUM} is reset. The voltage on C_{SUM} increases exponentially (and only slightly) with each clock cycle. The time for this voltage to reach a specific threshold is measured with a counter. Additional details regarding these alternative embodiments have not been included so as to not obscure the present embodiments, and because these alternative embodiments for measuring capacitance are known by those of ordinary skill in the art.

FIG. 3A illustrates a varying switch capacitance. In its basic form, a capacitive switch **300** is a pair of adjacent plates **301** and **302**. There is a small edge-to-edge capacitance C_p , but the intent of switch layout is to minimize the base capacitance C_p between these plates. When a conductive object **303** (e.g., finger) is placed in proximity to the two plate **301** and **302**, there is a capacitance $2 \cdot C_f$ between one electrode **301** and the conductive object **303** and a similar capacitance $2 \cdot C_f$ between the conductive object **303** and the other electrode **302**. The capacitance between one electrode **301** and the conductive object **303** and back to the other electrode **302** adds in parallel to the base capacitance C_p between the plates **301** and **302**, resulting in a change of capacitance C_f . Capacitive switch **300** may be used in a capacitance switch array. The capacitance switch array is a set of capacitors where one side of each is grounded. Thus, the active capacitor (as represented in FIG. 3B as capacitor **351**) has only one accessible side. The presence of the conductive object **303** increases the capacitance ($C_p + C_f$) of the switch **300** to ground. Determining switch activation is then a matter of measuring change in the capacitance (C_f). Switch **300** is also known as a grounded variable capacitor. In one exemplary embodiment, C_f may range from approximately 10-30 picofarads (pF). Alternatively, other ranges may be used.

The conductive object in this case is a finger, alternatively, this technique may be applied to any conductive object, for example, a conductive door switch, position sensor, or conductive pen in a stylus tracking system.

FIG. 3B illustrates one embodiment of a relaxation oscillator. The relaxation oscillator **350** is formed by the capacitance to be measured on capacitor **351**, a charging current source **352**, a comparator **353**, and a reset switch **354**. It should be noted that capacitor **351** is representative of the capacitance measured on a sensor element of a sensor array. The relaxation oscillator is coupled to drive a charging current (I_c) **357** in a single direction onto a device under test ("DUT") capacitor, capacitor **351**. As the charging current piles charge onto the capacitor **351**, the voltage across the capacitor increases with time as a function of I_c **357** and its capacitance C . Equation (1) describes the relation between current, capacitance, voltage and time for a charging capacitor.

$$CdV = I_c dt$$

(1)

The relaxation oscillator begins by charging the capacitor 351 from a ground potential or zero voltage and continues to pile charge on the capacitor 351 at a fixed charging current I_c 357 until the voltage across the capacitor 351 at node 355 reaches a reference voltage or threshold voltage, V_{TH} 355. At V_{TH} 355, the relaxation oscillator allows the accumulated charge at node 355 to discharge (e.g., the capacitor 351 to “relax” back to the ground potential) and then the process repeats itself. In particular, the output of comparator 353 asserts a clock signal F_{OUT} 356 (e.g., F_{OUT} 356 goes high), which enables the reset switch 354. This resets the voltage on the capacitor at node 355 to ground and the charge cycle starts again. The relaxation oscillator outputs a relaxation oscillator clock signal (F_{OUT} 356) having a frequency (f_{RO}) dependent upon capacitance C of the capacitor 351 and charging current I_c 357.

The comparator trip time of the comparator 353 and reset switch 354 add a fixed delay. The output of the comparator 353 is synchronized with a reference system clock to guarantee that the comparator reset time is long enough to completely reset the charging voltage on capacitor 355. This sets a practical upper limit to the operating frequency. For example, if capacitance C of the capacitor 351 changes, then f_{RO} will change proportionally according to Equation (1). By comparing f_{RO} of F_{OUT} 356 against the frequency (f_{REF}) of a known reference system clock signal (REF CLK), the change in capacitance ΔC can be measured. Accordingly, equations (2) and (3) below describe that a change in frequency between F_{OUT} 356 and REF CLK is proportional to a change in capacitance of the capacitor 351.

$$\Delta C \propto \Delta f, \text{ where} \quad (2)$$

$$\Delta f = f_{RO} - f_{REF}. \quad (3)$$

In one embodiment, a frequency comparator may be coupled to receive relaxation oscillator clock signal (F_{OUT} 356) and REF CLK, compare their frequencies f_{RO} and f_{REF} , respectively, and output a signal indicative of the difference Δf between these frequencies. By monitoring Δf one can determine whether the capacitance of the capacitor 351 has changed.

In one exemplary embodiment, the relaxation oscillator 350 may be built using a programmable timer (e.g., 555 timer) to implement the comparator 353 and reset switch 354. Alternatively, the relaxation oscillator 350 may be built using other circuiting. Relaxation oscillators are known in by those of ordinary skill in the art, and accordingly, additional details regarding their operation have not been included so as to not obscure the present embodiments.

FIG. 4 illustrates a block diagram of one embodiment of a capacitance sensor including a relaxation oscillator and digital counter. Capacitance sensor 201 of FIG. 4 includes a sensor array 410 (also known as a switch array), relaxation oscillator 350, and a digital counter 420. Sensor array 410 includes a plurality of sensor elements 355(1)-355(N), where N is a positive integer value that represents the number of rows (or alternatively columns) of the sensor array 410. Each sensor element is represented as a capacitor, as previously described with respect to FIG. 3B. The sensor array 410 is coupled to relaxation oscillator 350 via an analog bus 401 having a plurality of pins 401(1)-401(N). In one embodiment, the sensor array 410 may be a single-dimension sensor array including the sensor elements 355(1)-355(N), where N is a positive integer value that represents the number of sensor elements of the single-dimension sensor array. The single-dimension sensor array 410 provides output data to the analog bus 401 of the processing device 210 (e.g., via lines 231).

Alternatively, the sensor array 410 may be a multi-dimension sensor array including the sensor elements 355(1)-355(N), where N is a positive integer value that represents the number of sensor elements of the multi-dimension sensor array. The multi-dimension sensor array 410 provides output data to the analog bus 401 of the processing device 210 (e.g., via bus 221).

Relaxation oscillator 350 of FIG. 4 includes all the components described with respect to FIG. 3B, and a selection circuit 430. The selection circuit 430 is coupled to the plurality of sensor elements 355(1)-355(N), the reset switch 354, the current source 352, and the comparator 353. Selection circuit 430 may be used to allow the relaxation oscillator 350 to measure capacitance on multiple sensor elements (e.g., rows or columns). The selection circuit 430 may be configured to sequentially select a sensor element of the plurality of sensor elements to provide the charge current and to measure the capacitance of each sensor element. In one exemplary embodiment, the selection circuit 430 is a multiplexer array of the relaxation oscillator 350. Alternatively, selection circuit may be other circuitry outside the relaxation oscillator 350, or even outside the capacitance sensor 201 to select the sensor element to be measured. Capacitance sensor 201 may include one relaxation oscillator and digital counter for the plurality of sensor elements of the sensor array. Alternatively, capacitance sensor 201 may include multiple relaxation oscillators and digital counters to measure capacitance on the plurality of sensor elements of the sensor array. The multiplexer array may also be used to ground the sensor elements that are not being measured. This may be done in conjunction with a dedicated pin in the GP10 port 207.

In another embodiment, the capacitance sensor 201 may be configured to simultaneously scan the sensor elements, as opposed to being configured to sequentially scan the sensor elements as described above. For example, the sensing device may include a sensor array having a plurality of rows and columns. The rows may be scanned simultaneously, and the columns may be scanned simultaneously.

In one exemplary embodiment, the voltages on all of the rows of the sensor array are simultaneously moved, while the voltages of the columns are held at a constant voltage, with the complete set of sampled points simultaneously giving a profile of the conductive object in a first dimension. Next, the voltages on all of the rows are held at a constant voltage, while the voltages on all the rows are simultaneously moved, to obtain a complete set of sampled points simultaneously giving a profile of the conductive object in the other dimension.

In another exemplary embodiment, the voltages on all of the rows of the sensor array are simultaneously moved in a positive direction, while the voltages of the columns are moved in a negative direction. Next, the voltages on all of the rows of the sensor array are simultaneously moved in a negative direction, while the voltages of the columns are moved in a positive direction. This technique doubles the effect of any transcapacitance between the two dimensions, or conversely, halves the effect of any parasitic capacitance to the ground. In both methods, the capacitive information from the sensing process provides a profile of the presence of the conductive object to the sensing device in each dimension. Alternatively, other methods for scanning known by those of ordinary skill in the art may be used to scan the sensing device.

Digital counter 420 is coupled to the output of the relaxation oscillator 350. Digital counter 420 receives the relaxation oscillator output signal 356 (F_{OUT}). Digital counter 420 is configured to count at least one of a frequency or a period of the relaxation oscillator output received from the relaxation oscillator.

11

As previously described with respect to the relaxation oscillator 350, when a finger or conductive object is placed on the switch, the capacitance increases from C_p to C_p+C_f so the relaxation oscillator output signal 356 (F_{OUT}) decreases. The relaxation oscillator output signal 356 (F_{OUT}) is fed to the digital counter 420 for measurement. There are two methods for counting the relaxation oscillator output signal 356, frequency measurement and period measurement. In one embodiment, the digital counter 420 may include two multiplexers 423 and 424. Multiplexers 423 and 424 are configured to select the inputs for the PWM 421 and the timer 422 for the two measurement methods, frequency and period measurement methods. Alternatively, other selection circuits may be used to select the inputs for the PWM 421 and the time 422. In another embodiment, multiplexers 423 and 424 are not included in the digital counter, for example, the digital counter 420 may be configured in one, or the other, measurement configuration.

In the frequency measurement method, the relaxation oscillator output signal 356 is counted for a fixed period of time. The counter 422 is read to obtain the number of counts during the gate time. This method works well at low frequencies where the oscillator reset time is small compared to the oscillator period. A pulse width modulator (PWM) 441 is clocked for a fixed period by a derivative of the system clock, VC3 426 (which is a divider from system clock 425, e.g., 24 MHz). Pulse width modulation is a modulation technique that generates variable-length pulses to represent the amplitude of an analog input signal; in this case VC3 426. The output of PWM 421 enables timer 422 (e.g., 16-bit). The relaxation oscillator output signal 356 clocks the timer 422. The timer 422 is reset at the start of the sequence, and the count value is read out at the end of the gate period.

In the period measurement method, the relaxation oscillator output signal 356 gates a counter 422, which is clocked by the system clock 425 (e.g., 24 MHz). In order to improve sensitivity and resolution, multiple periods of the oscillator are counted with the PWM 421. The output of PWM 421 is used to gate the timer 422. In this method, the relaxation oscillator output signal 356 drives the clock input of PWM 421. As previously described, pulse width modulation is a modulation technique that generates variable-length pulses to represent the amplitude of an analog input signal; in this case the relaxation oscillator output signal 356. The output of the PWM 421 enables timer 422 (e.g., 16-bit), which is clocked at the system clock frequency 425 (e.g., 24 MHz). When the output of PWM 421 is asserted (e.g., goes high), the count starts by releasing the capture control. When the terminal count of the PWM 421 is reached, the capture signal is asserted (e.g., goes high), stopping the count and setting the PWM's interrupt. The timer value is read in this interrupt. The relaxation oscillator 350 is indexed to the next switch (e.g., capacitor 351(2)) to be measured and the count sequence is started again.

The two counting methods may have equivalent performance in sensitivity and signal-to-noise ratio (SNR). The period measurement method may have a slightly faster data acquisition rate, but this rate is dependent on software loads and the values of the switch capacitances. The frequency measurement method has a fixed-switch data acquisition rate.

The length of the counter 422 and the detection time required for the switch are determined by sensitivity requirements. Small changes in the capacitance on capacitor 351 result in small changes in frequency. In order to find these small changes, it may be necessary to count for a considerable time.

12

At startup (or boot) the switches (e.g., capacitors 351(1)-(N)) are scanned and the count values for each switch with no actuation are stored as a baseline array (C_p). The presence of a finger on the switch is determined by the difference in counts between a stored value for no switch actuation and the acquired value with switch actuation, referred to here as Δn . The sensitivity of a single switch is approximately:

$$\frac{\Delta n}{n} = \frac{C_f}{C_p} \quad (4)$$

The value of Δn should be large enough for reasonable resolution and clear indication of switch actuation. This drives switch construction decisions.

C_f should be as large a fraction of C_p as possible. In one exemplary embodiment, the fraction of C_f/C_p ranges between approximately 0.01 to approximately 2.0. Alternatively, other fractions may be used for C_f/C_p . Since C_f is determined by finger area and distance from the finger to the switch's conductive traces (through the over-lying insulator), the baseline capacitance C_p should be minimized. The baseline capacitance C_p includes the capacitance of the switch pad plus any parasitics, including routing and chip pin capacitance.

In switch array applications, variations in sensitivity should be minimized. If there are large differences in Δn , one switch may actuate at 1.0 cm, while another may not actuate until direct contact. This presents a non-ideal user interface device. There are numerous methods for balancing the sensitivity. These may include precisely matching on-board capacitance with PC trace length modification, adding balance capacitors on each switch's PC board trace, and/or adapting a calibration factor to each switch to be applied each time the switch is tested.

In one embodiment, the PCB design may be adapted to minimize capacitance, including thicker PCBs where possible. In one exemplary embodiment, a 0.062 inch thick PCB is used. Alternatively, other thicknesses may be used, for example, a 0.015 inch thick PCB.

It should be noted that the count window should be long enough for Δn to be a "significant number." In one embodiment, the "significant number" can be as little as 10, or alternatively, as much as several hundred. In one exemplary embodiment, where C_f is 1.0% of C_p (a typical "weak" switch), and where the switch threshold is set at a count value of 20, n is found to be:

$$n = \Delta n \cdot \frac{C_f}{C_p} = 2000 \quad (5)$$

Adding some margin to yield 2500 counts, and running the frequency measurement method at 1.0 MHz, the detection time for the switch is approximately 2.5 microseconds. In the frequency measurement method, the frequency difference between a switch with and without actuation (i.e., C_p+C_f vs. C_p) is approximately:

$$\Delta n = \frac{t_{count} \cdot i_c}{V_{TH}} \cdot \frac{C_f}{C_p^2} \quad (6)$$

This shows that the sensitivity variation between one channel and another is a function of the square of the difference in

the two channels' static capacitances. This sensitivity difference can be compensated using routines in the high-level Application Programming Interfaces (APIs).

In the period measurement method, the count difference between a switch with and without actuation (i.e., CP+CF vs. CP) is approximately:

$$\Delta n = N_{Periods} \cdot \frac{C_f \cdot V_{TH}}{i_C} \cdot f_{SysClk} \quad (7)$$

The charge currents are typically lower and the period is longer to increase sensitivity, or the number of periods for which f_{SysClk} is counted can be increased. In either method, by matching the static (parasitic) capacitances C_p of the individual switches, the repeatability of detection increases, making all switches work approximately at the same difference. Compensation for this variation can be done in software at runtime. The compensation algorithms for both the frequency method and period method may be included in the high-level APIs.

Some implementations of this circuit use a current source programmed by a fixed-resistor value. If the range of capacitance to be measured changes, external components, (i.e., the resistor) should be adjusted.

Using the multiplexer array **430**, multiple sensor elements may be sequentially scanned to provide current to and measure the capacitance from the capacitors (e.g., sensor elements), as previously described. In other words, while one sensor element is being measured, the remaining sensor elements are grounded using the GPIO port **207**. This drive and multiplex arrangement bypasses the existing GPIO to connect the selected pin to an internal analog multiplexer (mux) bus. The capacitor charging current (e.g., current source **352**) and reset switch **353** are connected to the analog mux bus. This may limit the pin-count requirement to simply the number of switches (e.g., capacitors **351(1)-351(N)**) to be addressed. In one exemplary embodiment, no external resistors or capacitors are required inside or outside the processing device **210** to enable operation.

The capacitor charging current for the relaxation oscillator **350** is generated in a register programmable current output DAC (also known as IDAC). Accordingly, the current source **352** is a current DAC or IDAC. The IDAC output current may be set by an 8-bit value provided by the processing device **210**, such as from the processing core **202**. The 8-bit value may be stored in a register or in memory.

Estimating and measuring PCB capacitances may be difficult; the oscillator-reset time may add to the oscillator period (especially at higher frequencies); and there may be some variation to the magnitude of the IDAC output current with operating frequency. Accordingly, the optimum oscillation frequency and operating current for a particular switch array may be determined to some degree by experimentation.

In many capacitive switch designs the two "plates" (e.g., **301** and **302**) of the sensing capacitor are actually adjacent sensor elements that are electrically isolated (e.g., PCB pads or traces), as indicated in FIG. **3A**. Typically, one of these plates is grounded. Layouts for touch-sensor slider (e.g., linear slide switches) and touch-sensor pad applications have switches that are immediately adjacent. In this case, all of the switches that are not active are grounded through the GPIO **207** of the processing device **210** dedicated to that pin. The actual capacitance between adjacent plates is small (C_p), but the capacitance of the active plate (and its PCB trace back to the processing device **210**) to ground, when detecting the

presence of the conductive object **303**, may be considerably higher (C_p+C_f). The capacitance of two parallel plates is given by the following equation:

$$C = \epsilon_0 \cdot \epsilon_R \cdot \frac{A}{d} = \epsilon_R \cdot 8.85 \cdot \frac{A}{d} \text{ pF/m} \quad (8)$$

The dimensions of equation (8) are in meters. This is a very simple model of the capacitance. The reality is that there are fringing effects that substantially increase the switch-to-ground (and PCB trace-to-ground) capacitance.

Switch sensitivity (i.e., actuation distance) may be increased by one or more of the following: 1) increasing board thickness to increase the distance between the active switch and any parasitics; 2) minimizing PC trace routing underneath switches; 3) utilizing a grided ground with 50% or less fill if use of a ground plane is absolutely necessary; 4) increasing the spacing between switch pads and any adjacent ground plane; 5) increasing pad area; 6) decreasing thickness of any insulating overlay; or 7) verifying that there is no air-gap between the PC pad surface and the touching finger.

There is some variation of switch sensitivity as a result of environmental factors. A baseline update routine, which compensates for this variation, may be provided in the high-level APIs.

Sliding switches are used for control requiring gradual adjustments. Examples include a lighting control (dimmer), volume control, graphic equalizer, and speed control. These switches are mechanically adjacent to one another. Actuation of one switch results in partial actuation of physically adjacent switches. The actual position in the sliding switch is found by computing the centroid location of the set of switches activated.

In applications for touch-sensor sliders (e.g., sliding switches) and touch-sensor pads it is often necessary to determine finger (or other capacitive object) position to more resolution than the native pitch of the individual switches. The contact area of a finger on a sliding switch or a touch-pad is often larger than any single switch. In one embodiment, in order to calculate the interpolated position using a centroid, the array is first scanned to verify that a given switch location is valid. The requirement is for some number of adjacent switch signals to be above a noise threshold. When the strongest signal is found, this signal and those immediately adjacent are used to compute a centroid:

$$\text{Centroid} = \frac{n_{i-1} \cdot (i-1) + n_i \cdot i + n_{i+1} \cdot (i+1)}{n_{i-1} + n_i + n_{i+1}} \quad (9)$$

The calculated value will almost certainly be fractional. In order to report the centroid to a specific resolution, for example a range of 0 to 100 for 12 switches, the centroid value may be multiplied by a calculated scalar. It may be more efficient to combine the interpolation and scaling operations into a single calculation and report this result directly in the desired scale. This may be handled in the high-level APIs. Alternatively, other methods may be used to interpolate the position of the conductive object.

A physical touchpad assembly is a multi-layered module to detect a conductive object. In one embodiment, the multi-layer stack-up of a touchpad assembly includes a PCB, an adhesive layer, and an overlay. The PCB includes the processing device **210** and other components, such as the connector to the host **250**, necessary for operations for sensing the

capacitance. These components are on the non-sensing side of the PCB. The PCB also includes the sensor array on the opposite side, the sensing side of the PCB. Alternatively, other multi-layer stack-ups may be used in the touchpad assembly.

The PCB may be made of standard materials, such as FR4 or Kapton™ (e.g., flexible PCB). In either case, the processing device 210 may be attached (e.g., soldered) directly to the sensing PCB (e.g., attached to the non-sensing side of the PCB). The PCB thickness varies depending on multiple variables, including height restrictions and sensitivity requirements. In one embodiment, the PCB thickness is at least approximately 0.3 millimeters (mm). Alternatively, the PCB may have other thicknesses. It should be noted that thicker PCBs may yield better results. The PCB length and width is dependent on individual design requirements for the device on which the sensing device is mounted, such as a notebook or mobile handset.

The adhesive layer is directly on top of the PCB sensing array and is used to affix the overlay to the overall touchpad assembly. Typical material used for connecting the overlay to the PCB is non-conductive adhesive such as 3M 467 or 468. In one exemplary embodiment, the adhesive thickness is approximately 0.05 mm. Alternatively, other thicknesses may be used.

The overlay may be non-conductive material used to protect the PCB circuitry to environmental elements and to insulate the user's finger (e.g., conductive object) from the circuitry. Overlay can be ABS plastic, polycarbonate, glass, or Mylar™. Alternatively, other materials known by those of ordinary skill in the art may be used. In one exemplary embodiment, the overlay has a thickness of approximately 1.0 mm. In another exemplary embodiment, the overlay thickness has a thickness of approximately 2.0 mm. Alternatively, other thicknesses may be used.

The sensor array may be a grid-like pattern of sensor elements (e.g., capacitive elements) used in conjunction with the processing device 210 to detect a presence of a conductive object, such as finger, to a resolution greater than that which is native. The touch-sensor pad layout pattern maximizes the area covered by conductive material, such as copper, in relation to spaces necessary to define the rows and columns of the sensor array.

FIG. 5A illustrates a top-side view of one embodiment of a sensor array having a plurality of sensor elements for detecting a presence of a conductive object 303 on the sensor array 500 of a touch-sensor pad. Touch-sensor pad 220 includes a sensor array 500. Sensor array 500 includes a plurality of rows 504(1)-504(N) and a plurality of columns 505(1)-505(M), where N is a positive integer value representative of the number of rows and M is a positive integer value representative of the number of columns. Each row includes a plurality of sensor elements 503(1)-503(K), where K is a positive integer value representative of the number of sensor elements in the row. Each column includes a plurality of sensor elements 501(1)-501(L), where L is a positive integer value representative of the number of sensor elements in the column. Accordingly, sensor array is an N×M sensor matrix. The N×M sensor matrix, in conjunction with the processing device 210, is configured to detect a position of a presence of the conductive object 303 in the x-, and y-directions.

FIG. 5B illustrates a top-side view of one embodiment of a sensor array having a plurality of sensor elements for detecting a presence of a conductive object 303 on the sensor array 550 of a touch-sensor slider. Touch-sensor slider 230 includes a sensor array 550. Sensor array 550 includes a plurality of columns 504(1)-504(M), where M is a positive integer value

representative of the number of columns. Each column includes a plurality of sensor elements 501(1)-501(L), where L is a positive integer value representative of the number of sensor elements in the column. Accordingly, sensor array is a 1×M sensor matrix. The 1×M sensor matrix, in conjunction with the processing device 210, is configured to detect a position of a presence of the conductive object 303 in the x-direction. It should be noted that sensor array 500 may be configured to function as a touch-sensor slider 230.

Alternating columns in FIG. 5A correspond to x- and y-axis elements. The y-axis sensor elements 503(1)-503(K) are illustrated as black diamonds in FIG. 5A, and the x-axis sensor elements 501(1)-501(L) are illustrated as white diamonds in FIG. 5A and FIG. 5B. It should be noted that other shapes may be used for the sensor elements. In another embodiment, the columns and row may include vertical and horizontal bars (e.g., rectangular shaped bars); however, this design may include additional layers in the PCB to allow the vertical and horizontal bars to be positioned on the PCB so that they are not in contact with one another.

FIGS. 5C and 5D illustrate top-side and side views of one embodiment of a two-layer touch-sensor pad. Touch-sensor pad, as illustrated in FIGS. 5C and 5D, include the first two columns 505(1) and 505(2), and the first four rows 504(1)-504(4) of sensor array 500. The sensor elements of the first column 501(1) are connected together in the top conductive layer 575, illustrated as hashed diamond sensor elements and connections. The diamond sensor elements of each column, in effect, form a chain of elements. The sensor elements of the second column 501(2) are similarly connected in the top conductive layer 575. The sensor elements of the first row 504(1) are connected together in the bottom conductive layer 576 using vias 577, illustrated as black diamond sensor elements and connections. The diamond sensor elements of each row, in effect, form a chain of elements. The sensor elements of the second, third, and fourth rows 504(2)-504(4) are similarly connected in the bottom conductive layer 576.

As illustrated in FIG. 5D, the top conductive layer 575 includes the sensor elements for both the columns and the rows of the sensor array, as well as the connections between the sensor elements of the columns of the sensor array. The bottom conductive layer 576 includes the conductive paths that connect the sensor elements of the rows that reside in the top conductive layer 575. The conductive paths between the sensor elements of the rows use vias 577 to connect to one another in the bottom conductive layer 576. Vias 577 go from the top conductive layer 575, through the dielectric layer 578, to the bottom conductive layer 576. Coating layers 579 and 589 are applied to the surfaces opposite to the surfaces that are coupled to the dielectric layer 578 on both the top and bottom conductive layers 575 and 576.

It should be noted that the space between coating layers 579 and 589 and dielectric layer 578, which does not include any conductive material, may be filled with the same material as the coating layers or dielectric layer. Alternatively, it may be filled with other materials.

It should be noted that the present embodiments are not limited to connecting the sensor elements of the rows using vias to the bottom conductive layer 576, but may include connecting the sensor elements of the columns using vias to the bottom conductive layer 576. Furthermore, the present embodiments are not limited to two-layer configurations, but may include disposing the sensor elements on multiple layers, such as three- or four-layer configurations.

When pins are not being sensed (only one pin is sensed at a time), they are routed to ground. By surrounding the sensing

17

device (e.g., touch-sensor pad) with a ground plane, the exterior elements have the same fringe capacitance to ground as the interior elements.

In one embodiment, an IC including the processing device **210** may be directly placed on the non-sensor side of the PCB. This placement does not necessary have to be in the center. The processing device IC is not required to have a specific set of dimensions for a touch-sensor pad, nor a certain number of pins. Alternatively, the IC may be placed somewhere external to the PCB.

FIG. 6A illustrates one embodiment of a sensing device having three touch-sensor buttons. Sensing device **240** of FIG. 6A includes buttons **601**, **602**, and **603**. These three buttons may be used for user input using a conductive object, such as a finger.

FIG. 6B illustrates one embodiment of the sensing device of FIG. 6A coupled to a processing device **210**. Processing device **210** is used to detect whether a conductive object is present on either, or none, of the touch-sensor buttons **601-603**. To detect the presence of the conductive object, the processing device **210** may include capacitance sensors **201(1)** and **201(2)**, which are coupled to buttons **601-603**. In particular, button **601** is coupled to capacitance sensor **201(1)**, button **603** is coupled to capacitance sensor **201(2)**, and button **602** is coupled to both capacitance sensor **201(1)** and **201(2)**.

Each of the conventional touch-sensor buttons **601-603** may be made of a sensor element of conductive material, such as copper-clad. The conductive material may be formed in a circular shape (illustrated in FIGS. 6A-6D), in a rectangular shape, or in a square shape (illustrated in FIGS. 7A and 7B). The touch-sensor buttons may be capacitance sensor buttons, which may be used as non-contact switches. These switches, when protected by an insulating layer, offer resistance to severe environments.

The sensing device of FIG. 6B includes two sensing areas **613** and **614** of conductive material that are electrically isolated. The sensing areas of conductive area are used to make up the three buttons **601-603**. In particular, button **601** includes a sensor element having a surface area of one conductive material (illustrated as white surface area of button **601**). Similarly, button **603** includes a sensor element having a surface area of another conductive material (illustrated as hashed surface area of button **603**). The conductive materials may be similar or dissimilar materials, but more importantly, are electrically isolated from one another. For example, button **601** is coupled to a first pin **609**, and button **603** is coupled to a second pin **610** of processing device **210**. Button **602**, however, includes a sensor element having a surface area of two conductive materials (illustrated as white and hashed surface areas of button **603**) that are electrically isolated. A portion, first portion **604**, of the sensor element of button **602** is coupled to the conductive material of button **601**, and another portion, second portion **605**, is coupled to the conductive material of button **603**.

In one embodiment, first portion **604** is coupled to the sensor element of button **601** using a conductive line **606**, and second portion **605** is coupled to the sensor element button **603** using a conductive line **607**. The conductive lines **606** and **607** may be conductive traces printed on the surface of the PCB. Alternatively, conductive lines may be conductive paths of conductive material that coupled the conductive material of the sensor elements and to the pins of the processing device **210**.

The processing device **210** scans the touch-sensor buttons **601-603** using the capacitance sensors **201(1)** and **201(2)**, and measures the capacitance on the two sensing areas of conduc-

18

tive material that realize the touch-sensor buttons **601-603**. The processing device is operable to recognize a first button operation on the first sensor element, a second button operation on the second sensor element, and third button operation on the first and second portions of the third sensor element. Accordingly, the capacitance sensors of the processing device are not coupled to the touch-sensor buttons in a one-to-one configuration, like that of the conventional sensing device.

In another embodiment, the processing device **210** may include only one capacitance sensor **201** that is coupled to a selection circuit. The selection circuit operates to select one conductive path to scan and measure. The processing device **210** includes two pins to couple to the two sensing areas of conductive material that make up the three or more buttons. In another embodiment, the processing device **210** may include only one pin and be coupled to a selection circuit that is external to the processing device that selects between the two sensing areas of conductive material.

In one embodiment, the processing device that is coupled to the sensing device of three or more touch-sensor buttons includes one more capacitance sensors coupled to the first and second sensor elements. The one or more capacitance sensors are operable to measure capacitance on the three or more sensor elements. For example, if the capacitance variation δ_1 , measured on the first pin **609**, is greater than zero, and the capacitance variation δ_2 , measured on the second pin **610** is equal to approximately zero, then the first button **601** has been pressed. Similarly, if the capacitance variation δ_1 , measured on the first pin **609**, is equal to the capacitance variation δ_2 , measured on the second pin **610**, then the second button **602** has been pressed. If the capacitance variation δ_1 , measured on the first pin **609**, is equal to approximately zero, and the capacitance variation δ_2 , measured on the second pin **610** is greater than zero, then the third button **603** has been pressed.

In one embodiment, the one or more capacitance sensors (e.g., **201(1)** and **201(2)**) may include a relaxation oscillator. The relaxation oscillator may be similar to the relaxation oscillator described above, which includes a current source, a selection circuit, a comparator, and a reset switch. The relaxation oscillator may be coupled to a digital counter that is operable to count at least one of a frequency or a period of a relaxation oscillator output received from the relaxation oscillator.

In one embodiment, the method may be performed by detecting a presence of a conductive object on a sensing device, and recognizing three or more button operations performed by the conductive object using two sensing areas of the sensing device. In one embodiment, the operation of recognizing the three or more button operations may include recognizing a first button operation when the presence of the conductive object is detected on a first sensing area **613** of the two sensing areas of the sensing device, recognizing a second button operation when the presence of the conductive object is detected on a second sensing area **614** of the two sensing areas of the sensing device, and recognizing one or more button operations when the presence of the conductive object is detected on the first and second sensing areas **613** and **614**.

The method may include the operation of determining a capacitance on each of the two sensing areas, and determining the three or more button operations based on the determined capacitance. The sensing areas **613** and **614** may be scanned sequentially, or alternatively, may be scanned simultaneously by one or more capacitance sensors of the processing device **210**.

In one embodiment, the two sensing areas may be used to realize three buttons, as illustrated in FIGS. 6A-6D. Alternatively, the two sensing areas may be used to realize more than

19

three button areas. In one embodiment, the sensor elements of the touch-sensor buttons may be circular shaped, as illustrated in FIGS. 6A-6D. Alternatively, the sensor elements may have other shapes, such as rectangles, squares, ovals, hexagon, octagons, or the like.

In one embodiment, portions 613 and 614 are substantially equal in surface area of the sensor element of button 602. Alternatively, portions 613 and 614 are not equal in surface area. In one embodiment, the portions of sensor element of button 602 are semi-circularly shaped. Alternatively, the portions of the sensor element may have other shapes.

FIG. 6C illustrates another embodiment of a sensing device having three touch-sensor buttons. Sensing device 600 includes three touch-sensor buttons that are similar to the touch-sensor buttons 601-603 of FIG. 6B, except the portions of the second sensor element of the second button 602 are dissimilarly shaped than the portions of FIG. 6B. First portion 604 of FIG. 6C has a shape of two pie shapes. Similarly, second portion 605 of FIG. 6C has a shape of two pie shapes. The four pie shapes form a substantially circular shape for the sensor element. In one embodiment, the two pie shapes of each portion are coupled together in a single layer, while the other two pie shapes are coupled together in a second conductive layer using vias, as described with respect to FIGS. 5C & 5D. Alternatively, the conductive material of one portion is coupled together using other methods known by those of ordinary skill in the art.

In the embodiment of FIG. 6C, conductive lines 606 and 607 are conductive traces that couple the first and second portions 604 and 605 to the first and third sensor elements of button 601 and 603, respectively. The conductive lines 607 and 608 may be comprised of similar or dissimilar materials as the conductive material of the sensor elements. It should be noted that first portion 604, sensor element of button 601, and conductive line 606 are electrically isolated from second portion 605, sensor element of button 603, and conductive line 607. Accordingly, the two sensing areas (e.g., 613 and 614) are comprised of these electrically isolated conductive materials.

In one embodiment, the first and second portions 604 and 605 each have a surface area that is substantially equal. Alternatively, the portions may have surface areas in other proportions.

FIG. 6D illustrates another embodiment of a sensing device having three touch-sensor buttons. Sensing device 650 includes three touch-sensor buttons that are similar to the touch-sensor buttons 601-603 of FIG. 6B, except the portions of the second sensor element of the second button 602 are dissimilarly shaped than the portions of FIG. 6B. First portion 604 of FIG. 6C has multiple arc shapes of conductive material that are electrically isolated from multiple arc shapes of another conductive material of second portion 605. The multiple arc shapes of both the first and second portions 604 and 605 form a substantially circular shape for the sensor element. In one embodiment, the multiple arc shapes of each portion are coupled together in a single layer, while the other two pie shapes are coupled together in a second conductive layer using vias, as described with respect to FIGS. 5C & 5D. Alternatively, the conductive material of one portion is coupled together using other methods known by those of ordinary skill in the art.

In the embodiment of FIG. 6D, conductive lines 606 and 607 are conductive traces that couple the first and second portions 604 and 605 to the first and third sensor elements of button 601 and 603, respectively. The conductive lines 607 and 608 may be comprised of similar or dissimilar materials as the conductive material of the sensor elements. It should be

20

noted that first portion 604, sensor element of button 601, and conductive line 606 are electrically isolated from second portion 605, sensor element of button 603, and conductive line 607. Accordingly, the two sensing areas (e.g., 613 and 614) are comprised of these electrically isolated conductive materials.

In one embodiment, the first and second portions 604 and 605 each have a surface area that is substantially equal. Alternatively, the portions may have surface areas in other proportions.

The shapes of the sensor elements and the portions of the sensor elements are not limited to the shapes illustrated and described herein, but may include other shapes. For example, FIGS. 7A and 7B include embodiments of rectangular and square shapes for the sensor elements and the portions of the sensor elements. In addition, the number of sensor elements in the sensing device is not limited to three, but may be greater than three. For example, FIGS. 7A and 7B illustrate embodiments of four and five touch-sensor buttons; however, more sensor elements than five may also be used.

FIG. 7A illustrates another embodiment of a sensing device having four touch-sensor buttons. Sensing device 700 includes four touch-sensor buttons 701-704. Each of the conventional touch-sensor buttons 701-704 may be made of a sensor element of conductive material, such as copper-clad. The sensor elements, in this embodiment are square shaped. The touch-sensor buttons may be capacitance sensor buttons, which may be used as non-contact switches.

The sensing device 700 of FIG. 7A includes two sensing areas of conductive material that are electrically isolated. The sensing areas of conductive area are used to make up the four buttons 701-704. In particular, button 701 includes a sensor element having a surface area of one conductive material (illustrated as white surface area of button 701). Similarly, button 704 includes a sensor element having a surface area of another conductive material (illustrated as hashed surface area of button 704). The conductive materials may be similar or dissimilar materials, but more importantly, are electrically isolated from one another. For example, button 701 is coupled to a first pin 609, and button 704 is coupled to a second pin 610 of processing device 210. Buttons 702 and 703, however, include a sensor element having a surface area of two conductive materials (illustrated as white and hashed surface areas of buttons 702 and 703) that are electrically isolated. A portion, first portion 710, of the sensor elements of buttons 702 and 703 is coupled to the conductive material of button 701, and another portion, second portion 711, is coupled to the conductive material of button 704.

In one embodiment, first portion 710 is coupled to the sensor element of button 701 using a conductive line 706, and second portion 711 is coupled to the sensor element button 704 using a conductive line 707. The conductive lines 706 and 707 may be conductive traces printed on the surface of the PCB. Alternatively, conductive lines 706 and 707 may be conductive paths of conductive material that coupled the conductive material of the sensor elements and to the pins of the processing device 210.

In one embodiment, each sensor element of buttons 702 and 703 comprises two surface areas, one surface area being the first portion 710, and the other surface area being the second portion 711. The surface areas may be one solid shape, or alternatively, the surface areas may be interleaved sub-traces. For example, the first conductive line 706 is a first conductive trace, and the first conductive trace has one or more sub-traces (e.g., 708(1)-708(7)), and the second conductive line 707 is a second conductive trace that has one or more sub-traces (e.g., 709(1)-709(7)). In one embodiment, at

least one sub-trace of the first conductive trace **706** is interleaved with at least one sub-trace of the second conductive trace **707**. Alternatively, the sub-traces of the first and second conductive traces are not interleaved.

The sensor elements of buttons **702** and **703** each have a surface area ratio between the surface area of the first portion **710** and the second portion **711**. In one embodiment, the surface area ratio of button **702** is approximately 25% of the first portion **710** to approximately 75% of the second portion **711** (25/75). The surface area ratio of button **703** is approximately 75% of the first portion **710** to approximately 25% of the second portion **711** (75/25). Alternatively, the surface area ratios of buttons **702** and **703** may be switched in surface area ratios, e.g., 75/25 for button **702** and 25/75 for button **703**. In another embodiment, button **702** and button **703** may have other surface area ratios, ranging from 99/1 to 49/51, and vice versa.

In the embodiment of FIG. 7A, buttons **702** and **703** each include seven sub-traces, sub-traces **708(1)-708(7)** and sub-traces **709(1)-709(7)**. In particular, button **702** includes four sub-traces **708(1)-708(4)** of the first portion **710**, and three sub-traces **709(1)-709(3)** of the second portion **711**. Button **703** includes three sub-traces **708(5)-708(7)** of the first portion **710**, and four sub-traces **709(4)-709(7)** of the second portion **711**. Accordingly, the surface area ratio of button **702** is 4/7 of the first portion **710** to 3/7 of the second portion **711**, and the surface area ratio of button **703** is 3/7 of the first portion **710** to 4/7 of the second portion **711**. Alternatively, other total number of sub-traces, and other combinations of sub-traces, may be used to form the different surface area ratios.

FIG. 7B illustrates another embodiment of a sensing device having five touch-sensor buttons. Sensing device **750** includes five touch-sensor buttons **701-705**. The touch-sensor buttons of sensing device **750** are similar to those of sensing device **700**, except there is one additional sensor element, and there are eight sub-traces per sensor element for buttons **702-704**, which consequently changes the surface area ratios.

The sensing device **750** of FIG. 7B includes two sensing areas (illustrates a white and hashed surface areas) of conductive material that are electrically isolated. The sensing areas of conductive area are used to make up the five buttons **701-705**.

In one embodiment, each sensor element of buttons **702**, **703**, and **704** comprises two surface areas, one surface area being the first portion **710**, and the other surface area being the second portion **711**. The surface areas may be one solid shape, or alternatively, the surface areas may be interleaved sub-traces. For example, the first conductive line **706** is a first conductive trace, and the first conductive trace has twelve sub-traces **708(1)-708(12)**, and the second conductive line **707** is a second conductive trace that has twelve sub-traces **709(1)-709(12)**. At least two sub-traces of both the first and second conductive traces are interleaved in each sensor element.

In this embodiment, the surface area ratio of button **702** is approximately 1/4 of the first portion **710** to approximately 3/4 of the second portion **711**. The surface area ratio of button **703** is approximately 3/4 (25%) of the first portion **710** to approximately 1/4 (50%) of the second portion **711**. The surface area ratio of button **704** is approximately 3/4 of the first portion **710** to approximately 1/4 of the second portion **711**.

In another embodiment, the surface area ratio of button **702** is approximately 25% of the first portion **710** to approximately 75% of the second portion **711**. The surface area ratio of button **703** is approximately 50% of the first portion **710** to approximately 50% of the second portion **711**. The surface

area ratio of button **704** is approximately 75% of the first portion **710** to approximately 25% of the second portion **711**.

In another embodiment, the surface area ratio of button **702** is approximately 33% of the first portion **710** to approximately 67% of the second portion **711**. The surface area ratio of button **703** is approximately 50% of the first portion **710** to approximately 50% of the second portion **711**. The surface area ratio of button **704** is approximately 67% of the first portion **710** to approximately 33% of the second portion **711**.

Alternatively, other surface area ratios, total number of sub-traces, and other combinations of sub-traces, may be used to form the sensor elements that include the two conductive materials.

As described with respect to the embodiments above, the processing device **210** can scan the touch-sensor buttons **701-704** of FIG. 7A (or the touch-sensor buttons **701-705** of FIG. 7B) using one or more capacitance sensors, and measure the capacitance on the two sensing areas of conductive material that realize the touch-sensor buttons **701-704** (or **701-705**). Accordingly, the processing device is operable to recognize a first button operation on the first sensor element, a second button operation on the second sensor element, and third and fourth button operations (or third, fourth, and fifth button operations) on the first and second portions of the third and fourth sensor elements (or third, fourth, and fifth sensor elements).

It should be noted that although the sensor elements that include the two portions are illustrated and described as being inside or in between the two sensor elements that are coupled to the pins, the sensor elements that include the two portions may be disposed in other positions with respect to the other two sensor elements.

Embodiments of the present invention, described herein, include various operations. These operations may be performed by hardware components, software, firmware, or a combination thereof. As used herein, the term "coupled to" may mean coupled directly or indirectly through one or more intervening components. Any of the signals provided over various buses described herein may be time multiplexed with other signals and provided over one or more common buses. Additionally, the interconnection between circuit components or blocks may be shown as buses or as single signal lines. Each of the buses may alternatively be one or more single signal lines and each of the single signal lines may alternatively be buses.

Certain embodiments may be implemented as a computer program product that may include instructions stored on a machine-readable medium. These instructions may be used to program a general-purpose or special-purpose processor to perform the described operations. A machine-readable medium includes any mechanism for storing or transmitting information in a form (e.g., software, processing application) readable by a machine (e.g., a computer). The machine-readable medium may include, but is not limited to, magnetic storage medium (e.g., floppy diskette); optical storage medium (e.g., CD-ROM); magneto-optical storage medium; read-only memory (ROM); random-access memory (RAM); erasable programmable memory (e.g., EPROM and EEPROM); flash memory; electrical, optical, acoustical, or other form of propagated signal (e.g., carrier waves, infrared signals, digital signals, etc.); or another type of medium suitable for storing electronic instructions.

Additionally, some embodiments may be practiced in distributed computing environments where the machine-readable medium is stored on and/or executed by more than one computer system. In addition, the information transferred

between computer systems may either be pulled or pushed across the communication medium connecting the computer systems.

Although the operations of the method(s) herein are shown and described in a particular order, the order of the operations of each method may be altered so that certain operations may be performed in an inverse order or so that certain operation may be performed, at least in part, concurrently with other operations. In another embodiment, instructions or sub-operations of distinct operations may be in an intermittent and/or alternating manner.

In the foregoing specification, the invention has been described with reference to specific exemplary embodiments thereof. It will, however, be evident that various modifications and changes may be made thereto without departing from the broader spirit and scope of the invention as set forth in the appended claims. The specification and drawings are, accordingly, to be regarded in an illustrative sense rather than a restrictive sense.

What is claimed is:

1. A method, comprising:
 - detecting a presence of a conductive object on a capacitance sensing device, the sensing device comprising at least two sensing areas each coupled to a capacitance measurement input; and
 - recognizing activation of at least three button performed by the detected presence of the conductive object, wherein the number of buttons is equal to at least the number of sensing areas plus one and wherein a combination of the at least two sensing areas is used to recognize at least one of the activated buttons.
2. The method of claim 1, wherein recognizing the plurality of button activations comprises:
 - recognizing a first activated button when the presence of the conductive object is detected on a first sensing area of the at least two sensing areas of the sensing device;
 - recognizing a second activated button when the presence of the conductive object is detected on a second sensing area of the at least two sensing areas of the sensing device; and
 - recognizing a third activated button when the presence of the conductive object is detected on the first and second sensing areas.
3. The method of claim 1, further comprising measuring a capacitance of the conductive object on the sensing device over time, wherein measuring the capacitance further comprises measuring a capacitance of the at least two sensing areas of the sensing device, and wherein recognizing the activated buttons is based on the measured capacitance of the at least two sensing areas.
4. The method of claim 1, further comprising scanning the at least two sensing areas of the sensing device, and wherein recognizing the a plurality of activated buttons comprises:
 - recognizing a first activated button when a first sensing area of the at least two sensing areas detects the presence of the conductive object during the scanning of the at least two sensing areas;
 - recognizing a second activated button when a second sensing area of the two sensing areas detects the presence of the conductive object during the scanning of the at least two sensing areas; and
 - recognizing a third activated button when the first and second sensing areas detect the presence of the conductive object during the scanning of the at least two sensing areas.

5. An apparatus, comprising:
 - a sensing device comprising:
 - a first sensor element;
 - a second sensor element; and
 - a third sensor element comprising a first portion coupled to the first sensor element and a second portion coupled to the second sensor element, wherein the first and second portions of the third sensor element are electrically isolated.
6. The apparatus of claim 5, wherein a surface area of the first portion and a surface area of the second portion of the third sensor element are substantially equal.
7. The apparatus of claim 5, further comprising a fourth sensor element comprising a third portion coupled to the first sensor element and a fourth portion coupled to the second sensor element, wherein the third and fourth portions of the fourth sensor element are electrically isolated.
8. The apparatus of claim 7, wherein a surface area ratio of the third sensor element is approximately 25% of the first portion to approximately 75% of the second portion, and wherein a surface area ratio of the fourth sensor element is approximately 75% of the third portion to approximately 25% of the fourth portion.
9. The apparatus of claim 5, further comprising a fifth sensor element comprising a fifth portion coupled to the first sensor element and a sixth portion coupled to the second sensor element, wherein the fifth and sixth portions of the fifth sensor element are electrically isolated.
10. The apparatus of claim 9, wherein a surface area ratio of the third sensor element is approximately 33% of the first portion to approximately 67% of the second portion, wherein a surface area ratio of the fourth sensor element is approximately 50% of the third portion to approximately 50% of the fourth portion, and wherein a surface area ratio of the fifth sensor element is approximately 67% of the fifth portion to approximately 33% of the sixth portion.
11. The apparatus of claim 5, wherein the first portion comprises a first conductive trace having one or more sub-traces, and the second portion comprises a second conductive trace having one or more sub-traces, and wherein at least one sub-trace of the first conductive trace is interleaved with at least one sub-trace of the second conductive trace.
12. The apparatus of claim 5, wherein the first, second, and third sensor elements are substantially circular shaped.
13. The apparatus of claim 5, wherein the first, second, and third sensor elements are substantially rectangular shaped.
14. The apparatus of claim 5, further comprising a processing device coupled to the sensing device, wherein the processing device comprises one or more capacitance sensors coupled to the first and second sensor elements, and wherein the one or more capacitance sensors are operable to measure capacitance on the first, second, and third sensor elements.
15. The apparatus of claim 14, wherein the processing device comprises a first pin and a second pin, wherein the first pin is coupled to the first sensor element, and wherein the second pin is coupled to the second sensor element.
16. The apparatus of claim 15, wherein the processing device is operable to recognize a first button operation on the first sensor element, a second button operation on the second sensor element, and a third button operation on the first and second portions of the third sensor element.
17. The apparatus of claim 14, wherein each of the one or more capacitance sensors comprises a relaxation oscillator coupled to one of the first sensor element and the first portion, and the second sensor element and the second portion, wherein the relaxation oscillator comprises:

25

a current source to provide a charge current to first sensor element and the first portion, and to the second sensor element and the second portion;

a selection circuit coupled to the first sensor element and the first portion, the second sensor element and the second portion, and the current source, wherein the selection circuit is configured to sequentially select a sensor element of the first sensor element and the second sensor elements to provide the charge current and to measure the capacitance of each sensor element of the sensing device;

a comparator coupled to the current source and the selection circuit, wherein the comparator is configured to compare a voltage on the selected sensor element and a threshold voltage; and

a reset switch coupled to the comparator, current source, and selection circuit, wherein the reset switch is configured to reset the charge current on the selected sensor element, and wherein each of the one or more capaci-

26

tance sensors further comprises a digital counter coupled to the relaxation oscillator, and wherein the digital counter is operable to count at least one of a frequency or a period of a relaxation oscillator output received from the relaxation oscillator.

- 18. An apparatus, comprising:
 - a first sensing area configured to detect a presence of a conductive object on a sensing device;
 - a second sensing area configured to detect the presence of the conductive object on the sensing device; and
 - means for recognizing three or more activated buttons performed by the conductive object using the first and second sensing areas on the sensing device.
- 19. The apparatus of claim 18, further comprising means for reducing a pin count of the sensing device.
- 20. The apparatus of claim 18, further comprising means for reducing scan time of the sensing device.

* * * * *