

UNITED STATES PATENT AND TRADEMARK OFFICE

BEFORE THE PATENT TRIAL AND APPEAL BOARD

TEMPUR SEALY INTERNATIONAL, INC.,
Petitioner,

v.

SELECT COMFORT CORP.,
Patent Owner.

Case IPR2014-01419
Patent 5,904,172 C1

Before PHILLIP J. KAUFFMAN, MEREDITH C. PETRAVICK, and
MITCHELL G. WEATHERLY, *Administrative Patent Judges*.

KAUFFMAN, *Administrative Patent Judge*.

DECISION
Denying Institution of *Inter Partes* Review
37 C.F.R. § 42.108

I. INTRODUCTION

Petitioner, Tempur Sealy International, Inc., seeks review of claims 2, 3, 6, 9, 12, 13, 16, and 20–25 of U.S. Patent No. 5,904,172¹ (issued May 18, 1999) (Ex. 1001, “the ’172 patent”). *See* Paper 1 (“Pet.”). Patent Owner, Select Comfort Corp., contends that Petitioner’s request should be denied. *See* Paper 6 (“Prelim. Resp.”). After considering the Petition and Preliminary Response, we determine that Petitioner has not established a reasonable likelihood of prevailing with respect to any of the challenged claims of the ’172 patent. *See* 35 U.S.C. § 314(a). Accordingly, we deny the Petition, and decline to institute *inter partes* review.

A. *Related Proceedings*

Petitioner states that Patent Owner has asserted infringement of the ’172 patent against the Petitioner in the co-pending district court case: *Select Comfort Corporation v. Tempur Sealy International, Inc.* d/b/a/ Tempur-Pedic (Civil Action No. 0: 14-cv-00245-JNE-JSM) (D. Minn.).² Pet. 2.

¹ *See* Ex Parte Reexamination Certificate, US 5,904,172 C1, issued Jan. 3, 2014 (Ex. 1003); Certificate of Correction, May 18, 1999 (Ex. 1005).

² Served on Petitioner on Feb. 7, 2014.

B. Asserted Grounds and Prior Art

Petitioner asserts the following grounds of unpatentability:

Claims challenged	Statutory Basis	References
6, 16, 20, 21	§ 103(a)	Kery ³ and Guthrie ⁴
2, 3, 12, 13, and 22–25	§ 103(a)	Kery, Moulton ⁵ , and Guthrie
9	§ 102(b)	Kery
9	§ 103(a)	Kery and Guthrie

C. The '172 Patent

The '172 patent relates to an electric pump for use with an inflatable mattress. Ex. 1001, 1:4–5. Valve enclosure assembly 100 includes processor board 20, and is preferably incorporated into an air mattress system having at least one bladder (e.g., left or right bladder 122, 124) fluidly coupled to pump 112. *Id.* at 2:56–57; 3:60–64; 4:3–10; Figs. 2, 3.

³ Ex. 1006, US Patent No. 3,784,994 (Jan. 15, 1974).

⁴ Ex. 1008, US Patent No. 5,235,713 (Aug. 17, 1993).

⁵ Ex. 1007, US Patent No. 4,527,298 (July 9, 1985).

Figure 3 of the '172 patent is reproduced below:

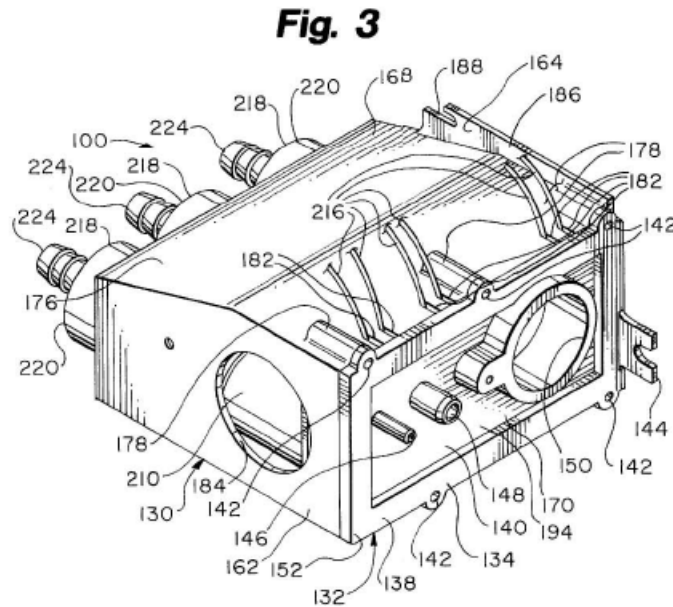

Figure 3 is a perspective view of the claimed valve assembly. Ex. 1001, 3:31–32.

Assembly 100 includes: an enclosure, at least one valve, and a pressure monitoring means. The enclosure (air chamber 133) is defined by enclosure 130 and rear cover 132. *Id.* at 4:17–20; Figs. 3, 10, 11. At least one valve (218) is disposed within assembly 100. *Id.* at 5:59–60; Figs. 3, 4. Valve member 226 of valve 218 is biased to the closed position. *Id.* at 2:37–39; 6:1–8; Fig. 7. When valve member 226 is unseated (open) air passes from the interior of valve assembly 100 through axial air passageway 222 to the respective bladder. *Id.* at 7:26–28; Fig. 7 (closed); Fig. 8 (open).

Pressure monitoring is accomplished by two different configurations. In a first embodiment, pressure monitoring port 146 is fluidly coupled to the interior of assembly 100 and includes an outwardly directed portion designed to receive a small tube for conveying pressure to a pressure sensor. *Id.* at 4:30–36; Fig. 3. In an alternative embodiment, pressure monitoring is

accomplished via a pressure monitor tab 240⁶ on valve body 220 of two of valves 218. *Id.* at 6:22–24; Fig. 9.

Of the challenged claims, claims 2, 6, 9, 12, 16, and 20 are independent. Claim 16 is illustrative and is reproduced below:

16. An improved valve enclosure assembly for use with an air inflatable mattress having at least one air bladder inflated by compressed air, a pump fluidly coupled to the at least one air bladder for providing compressed air thereto, and a processor for providing commands to the improved valve enclosure assembly during an inflate/deflate cycle, the improved valve enclosure assembly being fluidly coupled intermediate the pump and the at least one air bladder for controlling the inflation of the at least one air bladder, comprising:

an enclosure defining a substantially fluidly sealed air chamber and having at least one air inlet to the air chamber being fluidly coupled to the pump, the enclosure being formed of an enclosure portion and a rear cover portion, a flexible seal being compressively interposed between the enclosure portion and a rear cover portion to effect a substantially fluid tight seal therebetween;

at least one valve operably coupled to the enclosure being in selective fluid communication with the air chamber and being in fluid communication with the at least one air bladder for selectively fluidly coupling the air chamber to at least one air bladder; and

⁶ The '172 patent also refers to the expanded diameter portion of valve body 220 as element 240. Ex. 1001, 6:17–21, 36–37; Figs. 4, 6, 7, 9.

Explore Litigation Insights

Docket Alarm provides insights to develop a more informed litigation strategy and the peace of mind of knowing you're on top of things.

Real-Time Litigation Alerts



Keep your litigation team up-to-date with **real-time alerts** and advanced team management tools built for the enterprise, all while greatly reducing PACER spend.

Our comprehensive service means we can handle Federal, State, and Administrative courts across the country.

Advanced Docket Research



With over 230 million records, Docket Alarm's cloud-native docket research platform finds what other services can't. Coverage includes Federal, State, plus PTAB, TTAB, ITC and NLRB decisions, all in one place.

Identify arguments that have been successful in the past with full text, pinpoint searching. Link to case law cited within any court document via Fastcase.

Analytics At Your Fingertips



Learn what happened the last time a particular judge, opposing counsel or company faced cases similar to yours.

Advanced out-of-the-box PTAB and TTAB analytics are always at your fingertips.

API

Docket Alarm offers a powerful API (application programming interface) to developers that want to integrate case filings into their apps.

LAW FIRMS

Build custom dashboards for your attorneys and clients with live data direct from the court.

Automate many repetitive legal tasks like conflict checks, document management, and marketing.

FINANCIAL INSTITUTIONS

Litigation and bankruptcy checks for companies and debtors.

E-DISCOVERY AND LEGAL VENDORS

Sync your system to PACER to automate legal marketing.