

- [54] **HYBRID VEHICLE**
- [75] Inventors: **Kozo Yamaguchi; Yoshikazu Yamauchi; Hideki Nakashima**, all of Aichi-ken, Japan
- [73] Assignee: **Kabushikikaisha Equos Research**, Japan
- [21] Appl. No.: **609,762**
- [22] Filed: **Feb. 23, 1996**
- [30] **Foreign Application Priority Data**
 Feb. 28, 1995 [JP] Japan 7-063538
- [51] **Int. Cl.⁶** **B60K 6/00**
- [52] **U.S. Cl.** **180/65.2**
- [58] **Field of Search** 180/65.2, 65.3, 180/65.4, 65.6, 65.8; 364/424.026; 123/179.3

- [56] **References Cited**
U.S. PATENT DOCUMENTS
- 1,848,091 3/1932 Winther 180/65.2
- 3,566,717 3/1971 Berman et al. 180/65.2
- 3,623,568 11/1971 Mori 180/65.2
- 3,861,484 1/1975 Joslin et al. 180/65.2
- 4,022,164 5/1977 Fuchs 123/179.3
- 4,122,354 10/1978 Howland 123/179.3

- 4,196,785 4/1980 Downing, Jr. 180/65.4
- 4,335,429 6/1982 Kawakatsu 180/65.2
- 4,883,028 11/1989 Wu 123/179.3
- 5,343,970 9/1994 Severinsky 180/65.2
- 5,698,905 12/1997 Rütthlein 180/65.4

FOREIGN PATENT DOCUMENTS

- 0570234 5/1993 European Pat. Off. .
- 4-294977 5/1994 Japan 180/65.2

Primary Examiner—Brian L. Johnson
Assistant Examiner—Frank Vanaman
Attorney, Agent, or Firm—Lorusso & Loud

[57] **ABSTRACT**

A hybrid vehicle has an engine and a generator/motor connected through a planetary gear unit to an output shaft and the output of the engine is distributed between the generator and the output shaft. The vehicle is smoothly started by a driving motor. When vehicle speed V reaches an engine starting speed V*, the speed of generator/motor is changed to cause the engine to rotate, the engine is ignited and driving continues with the output torque produced by the engine supplemented by the driving motor. The hybrid vehicle allows for a smooth start and improved driving comfort even if an engine interruption scheme for halting the engine is employed, for example, halting the vehicle while waiting for a traffic signal to change.

19 Claims, 8 Drawing Sheets

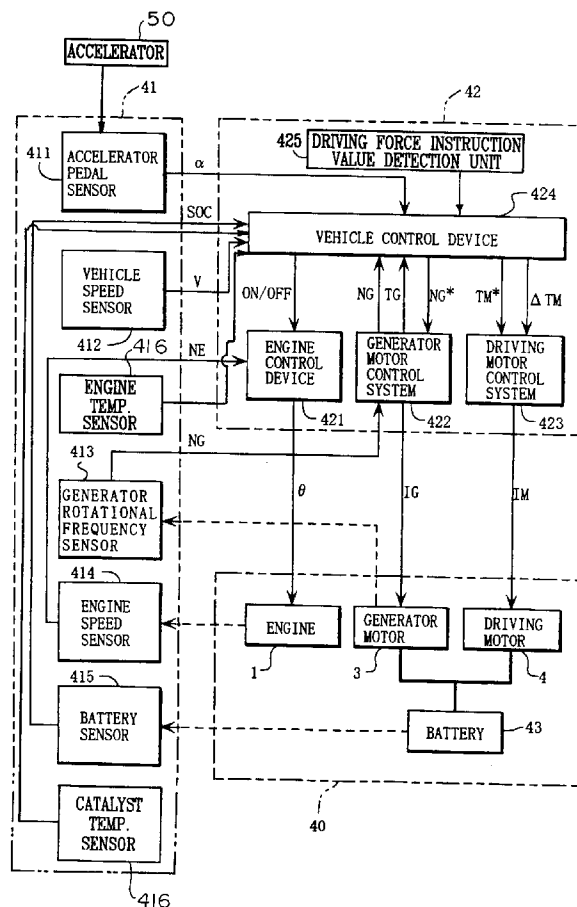
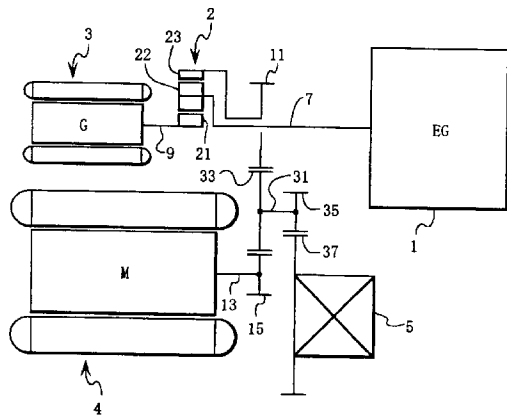

FIG. 1

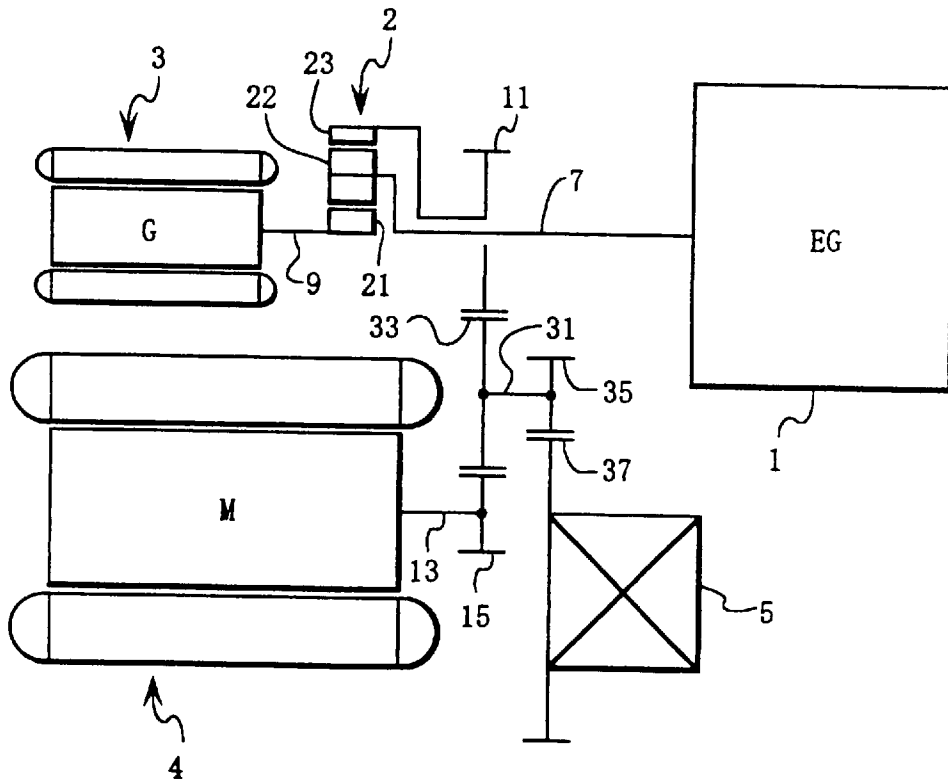

FIG. 2

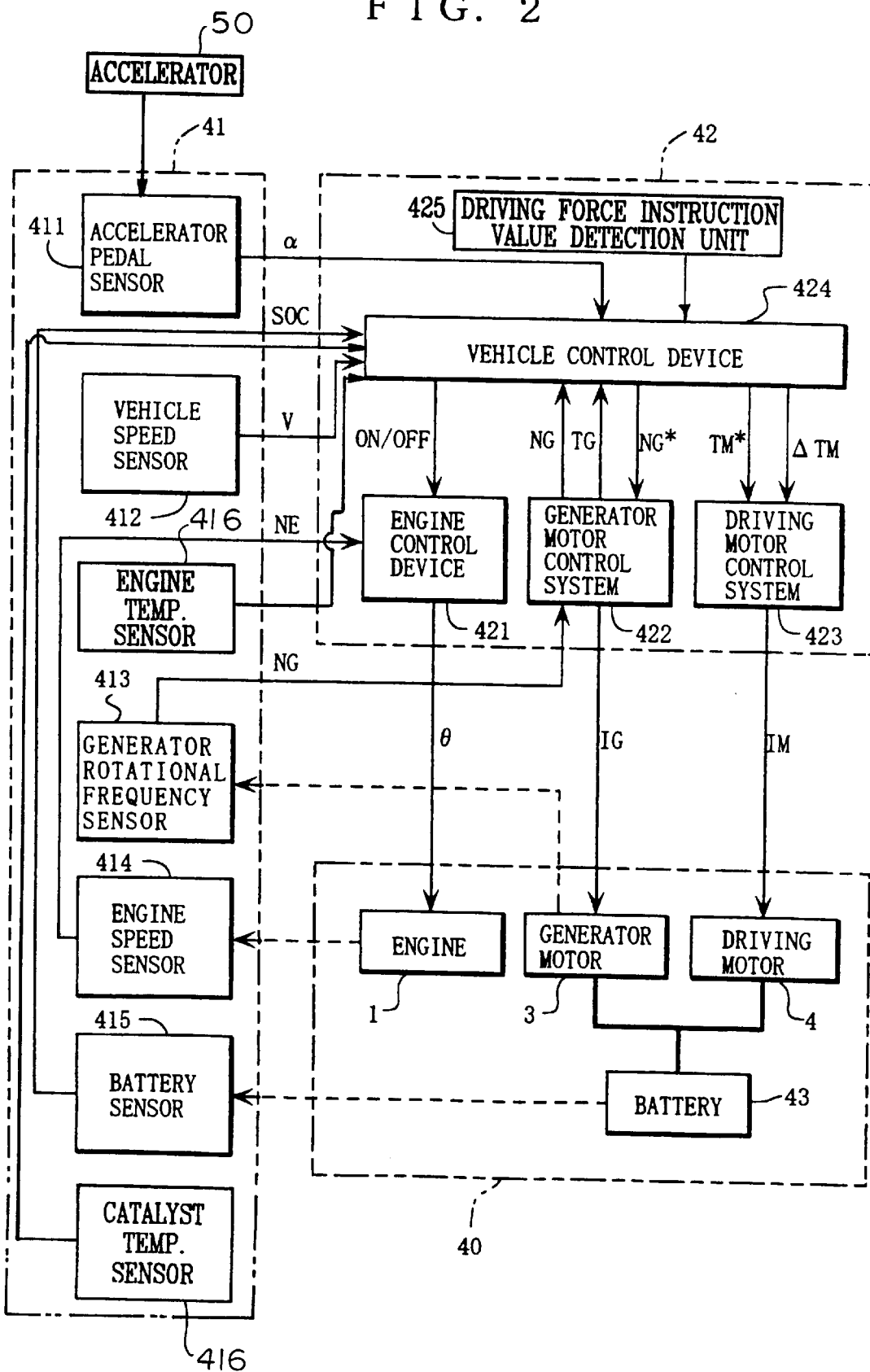

FIG. 3

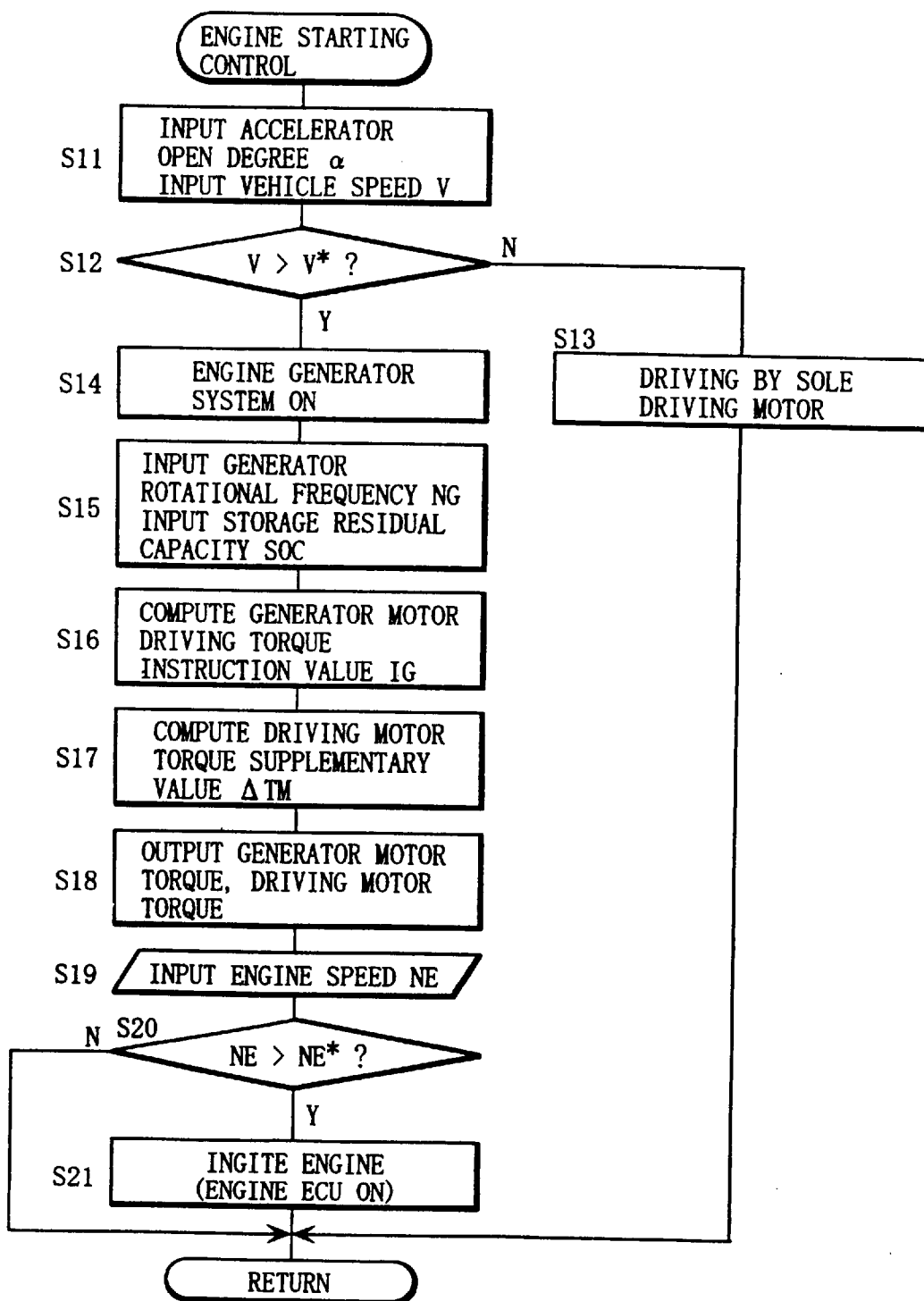

FIG. 4

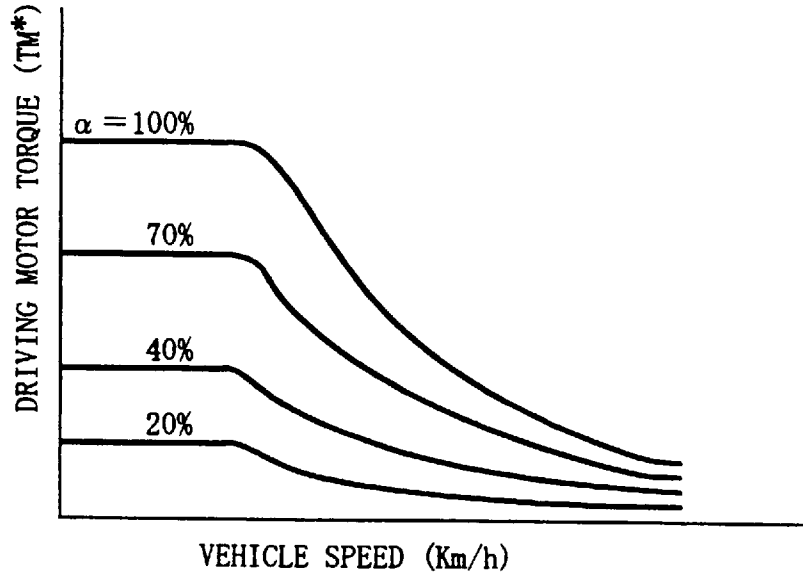
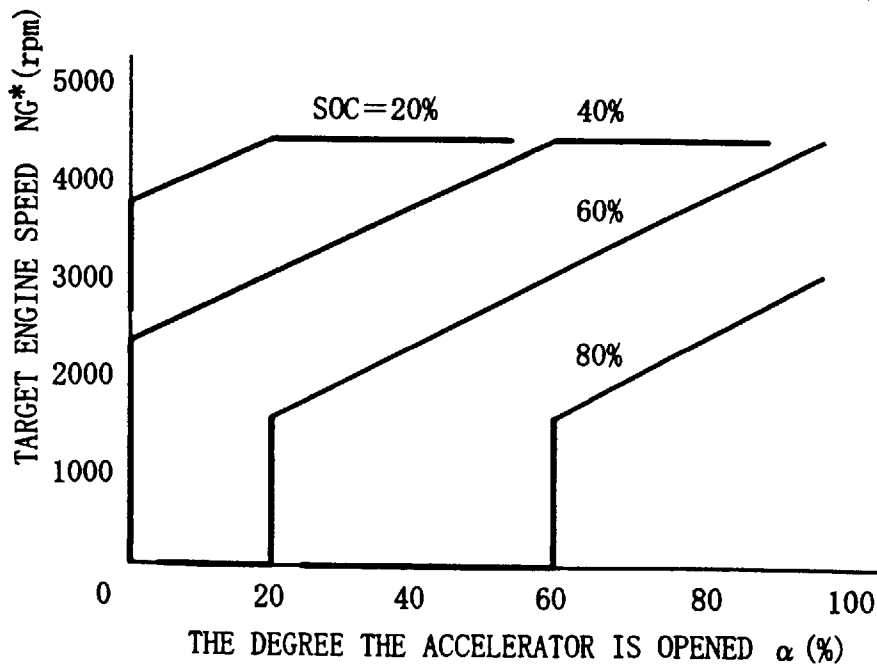

FIG. 5



Explore Litigation Insights

Docket Alarm provides insights to develop a more informed litigation strategy and the peace of mind of knowing you're on top of things.

Real-Time Litigation Alerts



Keep your litigation team up-to-date with **real-time alerts** and advanced team management tools built for the enterprise, all while greatly reducing PACER spend.

Our comprehensive service means we can handle Federal, State, and Administrative courts across the country.

Advanced Docket Research



With over 230 million records, Docket Alarm's cloud-native docket research platform finds what other services can't. Coverage includes Federal, State, plus PTAB, TTAB, ITC and NLRB decisions, all in one place.

Identify arguments that have been successful in the past with full text, pinpoint searching. Link to case law cited within any court document via Fastcase.

Analytics At Your Fingertips



Learn what happened the last time a particular judge, opposing counsel or company faced cases similar to yours.

Advanced out-of-the-box PTAB and TTAB analytics are always at your fingertips.

API

Docket Alarm offers a powerful API (application programming interface) to developers that want to integrate case filings into their apps.

LAW FIRMS

Build custom dashboards for your attorneys and clients with live data direct from the court.

Automate many repetitive legal tasks like conflict checks, document management, and marketing.

FINANCIAL INSTITUTIONS

Litigation and bankruptcy checks for companies and debtors.

E-DISCOVERY AND LEGAL VENDORS

Sync your system to PACER to automate legal marketing.