



EZ-USB[®] Technical Reference Manual

Document # 001-13670 Rev. *D

Cypress Semiconductor
198 Champion Court
San Jose, CA 95134-1709
Phone (USA): 800.858.1810
Phone (Intl): 408.943.2600
<http://www.cypress.com>

EXHIBIT 2031

LG Elecs. v. Cypress Semiconductor
IPR2014-01405, U.S. Pat. 6,493,770

Copyrights

Copyright © 2002 - 2011 Cypress Semiconductor Corporation. All rights reserved.

Cypress, the Cypress Logo, and EZ-USB are registered trademarks and MoBL-USB and ReNumeration are trademarks of Cypress Semiconductor Corporation. Macintosh is a registered trademark of Apple Computer, Inc. Windows is a registered trademark of Microsoft Corporation. SmartMedia is a trademark of Toshiba Corporation. All other product or company names used in this manual may be trademarks, registered trademarks, or servicemarks of their respective owners.

Purchase of I2C components from Cypress or one of its sublicensed Associated Companies conveys a license under the Philips I2C Patent Rights to use these components in an I2C system, provided that the system conforms to the I2C Standard Specification as defined by Philips. As from October 1st, 2006 Philips Semiconductors has a new trade name - NXP Semiconductors.

The information in this document is subject to change without notice and should not be construed as a commitment by Cypress. While reasonable precautions have been taken, Cypress assumes no responsibility for any errors that may appear in this document. No part of this document may be copied or reproduced in any form or by any means without the prior written consent of Cypress. Made in the U.S.A.

Disclaimer

CYPRESS MAKES NO WARRANTY OF ANY KIND, EXPRESS OR IMPLIED, WITH REGARD TO THIS MATERIAL, INCLUDING, BUT NOT LIMITED TO, THE IMPLIED WARRANTIES OF MERCHANTABILITY AND FITNESS FOR A PARTICULAR PURPOSE. Cypress reserves the right to make changes without further notice to the materials described herein. Cypress does not assume any liability arising out of the application or use of any product or circuit described herein. Cypress does not authorize its products for use as critical components in life-support systems where a malfunction or failure may reasonably be expected to result in significant injury to the user. The inclusion of Cypress' product in a life-support systems application implies that the manufacturer assumes all risk of such use and in doing so indemnifies Cypress against all charges.

The acceptance of this document will be construed as an acceptance of the foregoing conditions.

This manual is the EZ-USB[®] Technical Reference Manual, for EZ-USB FX2LP[™], and EZ-USB FX1[™]. It provides information for the chips listed below.

CY7C68013A

CY7C68014A

CY7C68015A

CY7C68016A

CY7C64713

Contents Overview



1. Introducing EZ-USB®	13
2. Endpoint Zero	37
3. Enumeration and ReNumeration™	51
4. Interrupts	59
5. Memory	71
6. Power Management	77
7. Resets	83
8. Access to Endpoint Buffers	87
9. Slave FIFOs	99
10. General Programmable Interface	121
11. CPU Introduction	169
12. Instruction Set	175
13. Input/Output	181
14. Timers/Counters and Serial Interface	193
15. Registers	211
Appendix A. Descriptors for Full-Speed Mode	367
Appendix B. Descriptors for High-Speed Mode	375
Appendix C. Device Register Summary	383
Index	395

Contents



1. Introducing EZ-USB®	13
1.1 An Introduction to USB	13
1.2 The USB Specification	14
1.3 Host is Master	14
1.4 USB Direction	14
1.5 Tokens and PIDs	14
1.5.1 Receiving Data from the Host	15
1.5.2 Sending Data to the Host	15
1.6 USB Frames	15
1.7 USB Transfer Types	15
1.7.1 Bulk Transfers	16
1.7.2 Interrupt Transfers	16
1.7.3 Isochronous Transfers	16
1.7.4 Control Transfers	16
1.8 Enumeration	16
1.8.1 Full Speed/High Speed Detection	17
1.9 The Serial Interface Engine	17
1.10 ReNumeration™	18
1.11 EZ-USB Architecture	18
1.12 EZ-USB Feature Summary	20
1.13 EZ-USB Integrated Microprocessor	20
1.14 EZ-USB Block Diagram	21
1.15 Packages	22
1.15.1 56-Pin Packages	22
1.15.2 CY7C68013A/14A and CY7C68015A/16A Differences	22
1.15.3 100-Pin Package	22
1.15.4 128-Pin Package	23
1.15.5 Signals Available in the Five Packages	23
1.16 Package Diagrams	25
1.17 EZ-USB Endpoint Buffers	30
1.18 External FIFO Interface	31
1.19 EZ-USB Product Family	34
1.20 Document History	35
2. Endpoint Zero	37
2.1 Introduction	37
2.2 Control Endpoint EP0	37
2.3 USB Requests	39
2.3.1 Get Status	40
2.3.2 Set Feature	42
2.3.3 Clear Feature	43

2.3.4	Get Descriptor	43
2.3.4.1	Get Descriptor-Device	44
2.3.4.2	Get Descriptor-Device Qualifier	45
2.3.4.3	Get Descriptor-Configuration	45
2.3.4.4	Get Descriptor-String	46
2.3.4.5	Get Descriptor-Other Speed Configuration	46
2.3.5	Set Descriptor	46
2.3.5.1	Set Configuration	47
2.3.6	Get Configuration	47
2.3.7	Set Interface	47
2.3.8	Get Interface	48
2.3.9	Set Address	48
2.3.10	Sync Frame	49
2.3.11	Firmware Load	49
3.	Enumeration and ReNumeration™	51
3.1	Introduction	51
3.2	EZ-USB Startup Modes	51
3.3	The Default USB Device	52
3.4	EEPROM Boot-load Data Formats	52
3.4.1	No EEPROM or Invalid EEPROM	52
3.4.2	Serial EEPROM Present, First Byte is 0xC0	53
3.4.3	Serial EEPROM Present, First Byte is 0xC2	53
3.4.3.1	General Purpose Use of the I2C Bus	54
3.5	EEPROM Configuration Byte	55
3.6	The RENUM Bit	56
3.7	EZ-USB Response to Device Requests (RENUM = 0)	56
3.8	EZ-USB Vendor Request for Firmware Load	56
3.9	How the Firmware ReNumerates	57
3.10	Multiple ReNumerations™	58
4.	Interrupts	59
4.1	Introduction	59
4.2	SFRs	59
4.2.1	803x/805x Compatibility	61
4.3	Interrupt Processing	62
4.3.1	Interrupt Masking	62
4.3.1.1	Interrupt Priorities	62
4.3.2	Interrupt Sampling	62
4.3.3	Interrupt Latency	63
4.4	USB-Specific Interrupts	63
4.4.1	Resume Interrupt	63
4.4.2	USB Interrupts	63
4.4.2.1	SUTOK, SUDAV Interrupts	66
4.4.2.2	SOF Interrupt	66
4.4.2.3	Suspend Interrupt	66
4.4.2.4	USB RESET Interrupt	66
4.4.2.5	HISPEED Interrupt (FX2LP only)	66
4.4.2.6	EP0ACK Interrupt	66
4.4.2.7	Endpoint Interrupts	66
4.4.2.8	In-Bulk-NAK (IBN) Interrupt	66
4.4.2.9	EPxPING Interrupt (FX2LP only)	67

4.4.2.10	ERRLIMIT Interrupt	67
4.4.2.11	EPxISOERR Interrupt	67
4.5	USB-Interrupt Autovectors.....	67
4.5.1	USB Autovector Coding	68
4.6	I ² C Bus Interrupt	68
4.7	FIFO/GPIF Interrupt (INT4)	69
4.8	FIFO/GPIF Interrupt Autovectors.....	69
4.8.1	FIFO/GPIF Autovector Coding	70
5.	Memory	71
5.1	Introduction.....	71
5.2	Internal Data RAM	71
5.2.1	The Lower 128	72
5.2.2	The Upper 128	72
5.2.3	Special Function Register Space.....	72
5.3	External Program Memory and External Data Memory.....	72
5.3.1	56- and 100-Pin EZ-USB Chips	73
5.3.2	128-Pin EZ-USB Chip	73
5.4	EZ-USB Memory Maps.....	74
5.5	'Von-Neumannizing' Off-Chip Program and Data Memory.....	76
5.6	On-Chip Data Memory at 0xE000-0xFFFF.....	76
6.	Power Management	77
6.1	Introduction.....	77
6.2	USB Suspend	79
6.2.1	Suspend Register.....	79
6.3	Wakeup/Resume	80
6.3.1	Wakeup Interrupt.....	81
6.4	USB Resume (Remote Wakeup)	81
6.4.1	WU2 Pin	81
7.	Resets	83
7.1	Introduction.....	83
7.2	Hard Reset	83
7.3	Releasing the CPU Reset.....	84
7.3.1	RAM Download	84
7.3.2	EEPROM Load.....	84
7.3.3	External ROM.....	84
7.4	CPU Reset Effects.....	84
7.5	USB Bus Reset.....	85
7.6	EZ-USB Disconnect.....	85
7.7	Reset Summary	85
8.	Access to Endpoint Buffers	87
8.1	Introduction.....	87
8.2	EZ-USB Large and Small Endpoints	87
8.3	High Speed and Full Speed Differences	87
8.4	How the CPU Configures the Endpoints	88
8.5	CPU Access to EZ-USB Endpoint Data	89
8.6	CPU Control of EZ-USB Endpoints	89

8.6.1	Registers That Control EP0, EP1IN, and EP1OUT	90
8.6.1.1	EP0CS	90
8.6.1.2	EP0BCH and EP0BCL	90
8.6.1.3	USBIE, USBIRQ	91
8.6.1.4	EP01STAT	91
8.6.1.5	EP1OUTCS	91
8.6.1.6	EP1OUTBC	91
8.6.1.7	EP1INCS	91
8.6.1.8	EP1INBC	92
8.6.2	Registers That Control EP2, EP4, EP6, EP8	92
8.6.2.1	EP2468STAT	92
8.6.2.2	EP2ISOINPKTS, EP4ISOINPKTS, EP6ISOINPKTS, EP8ISOINPKTS	92
8.6.2.3	EP2CS, EP4CS, EP6CS, EP8CS	92
8.6.2.4	EP2BCH:L, EP4BCH:L, EP6BCH:L, EP8BCH:L	93
8.6.3	Registers That Control All Endpoints	93
8.6.3.1	IBNIE, IBNIRQ, NAKIE, NAKIRQ	93
8.6.3.2	EPIE, EPIRQ	94
8.6.3.3	USBERRIE, USBERRIRQ, ERRCNTLIM, CLRERRCNT	94
8.6.3.4	TOGCTL	95
8.7	The Setup Data Pointer	95
8.7.1	Transfer Length	96
8.7.2	Accessible Memory Spaces	96
8.8	Autopointers	96
9.	Slave FIFOs	99
9.1	Introduction	99
9.2	Hardware	99
9.2.1	Slave FIFO Pins	100
9.2.2	FIFO Data Bus	101
9.2.3	Interface Clock	102
9.2.4	FIFO Flag Pins (FLAGA, FLAGB, FLAGC, FLAGD)	103
9.2.5	Control Pins (SLOE, SLRD, SLWR, PKTEND, FIFOADR[1:0])	103
9.2.6	Slave FIFO Chip Select	104
9.2.7	Implementing Synchronous Slave FIFO Writes	105
9.2.8	Implementing Synchronous Slave FIFO Reads	107
9.2.9	Implementing Asynchronous Slave FIFO Writes	108
9.2.10	Implementing Asynchronous Slave FIFO Reads	109
9.3	Firmware	110
9.3.1	Firmware FIFO Access	110
9.3.2	EPx Memories	111
9.3.3	Slave FIFO Programmable Level Flag	111
9.3.4	Auto-In / Auto-Out Modes	111
9.3.5	CPU Access to OUT Packets, AUTOOUT = 1	112
9.3.6	CPU Access to OUT Packets, AUTOOUT = 0	113
9.3.7	CPU Access to IN Packets, AUTOIN = 1	115
9.3.8	Access to IN Packets, AUTOIN=0	116
9.3.9	Auto In/Auto Out Initialization	117
9.3.10	Auto Mode: Synchronous FIFO IN Data Transfers	118
9.3.11	Auto Mode Example: Asynchronous FIFO IN Data Transfers	119
9.3.12	Skipping Out Packets while in AUTOOUT Mode	119
9.3.13	Aborting Packets in FIFO while in AUTOIN Mode	120
9.4	Switching Between Manual Out and Auto Out	120

10. General Programmable Interface	121
10.1 Introduction.....	121
10.1.1 Typical GPIF Interface.....	123
10.2 Hardware.....	123
10.2.1 The External GPIF Interface.....	124
10.2.2 Default GPIF Pins Configuration	124
10.2.3 Six Control OUT Signals	124
10.2.3.1 Control Output Modes	124
10.2.4 Six Ready IN Signals.....	124
10.2.5 Nine GPIF Address OUT Signals	124
10.2.6 Three GSTATE OUT Signals.....	124
10.2.7 8/16-Bit Data Path, WORDWIDE = 1 (default) and WORDWIDE = 0	125
10.2.8 Byte Order for 16 Bit GPIF Transactions.....	125
10.2.9 Interface Clock (IFCLK).....	125
10.2.10 Connecting GPIF Signal Pins to Hardware	126
10.2.11 Example GPIF Hardware Interconnect.....	126
10.3 Programming the GPIF Waveforms	127
10.3.1 The GPIF Registers.....	127
10.3.2 Programming GPIF Waveforms	127
10.3.2.1 The GPIF IDLE State	128
10.3.2.2 Defining States.....	128
10.3.3 Reexecuting a Task Within a DP State	131
10.3.4 State Instructions.....	134
10.3.4.1 Structure of the Waveform Descriptors	136
10.3.4.2 Terminating a GPIF Transfer	136
10.4 Firmware	137
10.4.1 Single Read Transactions	143
10.4.2 Single Write Transactions.....	147
10.4.3 FIFO Read and FIFO Write (Burst) Transactions.....	150
10.4.3.1 Transaction Counter.....	150
10.4.3.2 Reading the Transaction-Count Status in a DP State.....	150
10.4.4 GPIF Flag Selection	150
10.4.5 GPIF Flag Stop.....	150
10.4.5.1 Performing a FIFO Read Transaction	151
10.4.6 Firmware Access to IN Packets, (AUTOIN=1)	156
10.4.7 Firmware Access to IN Packets, (AUTOIN = 0)	157
10.4.7.1 Performing a FIFO-Write Transaction	159
10.4.8 Firmware Access to OUT packets, (AUTOOUT=1).....	164
10.4.9 Firmware Access to OUT Packets, (AUTOOUT = 0)	165
10.5 UDMA Interface	167
10.6 ECC Generation	167
11. CPU Introduction	169
11.1 Introduction.....	169
11.2 8051 Enhancements.....	170
11.3 Performance Overview	170
11.4 Software Compatibility.....	171
11.5 803x/805x Feature Comparison	171
11.6 EZ-USB/DS80C320 Differences.....	172
11.6.1 Serial Ports.....	172
11.6.2 Timer 2	172
11.6.3 Timed Access Protection.....	172

11.6.4	Watchdog Timer	172
11.6.5	Power Fail Detection	172
11.6.6	Port I/O	172
11.6.7	Interrupts	172
11.7	EZ-USB Register Interface	172
11.8	EZ-USB Internal RAM	172
11.9	I/O Ports	173
11.10	Interrupts	173
11.11	Power Control	173
11.12	Special Function Registers	174
11.13	External Address/Data Buses	174
11.14	Reset	174
12.	Instruction Set	175
12.1	Introduction	175
12.1.1	Instruction Timing	178
12.1.2	Stretch Memory Cycles	178
12.1.3	Dual Data Pointers	179
12.1.4	Special Function Registers	179
13.	Input/Output	181
13.1	Introduction	181
13.2	I/O Ports	181
13.3	SFR Registers	182
13.4	I/O Port Alternate Functions	183
13.4.1	Port A Alternate Functions	185
13.4.2	Port B and Port D Alternate Functions	186
13.4.3	Port C Alternate Functions	187
13.4.4	Port E Alternate Functions	188
13.5	I2C Bus Controller	189
13.5.1	Interfacing to I2C Peripherals	189
13.5.1.1	Multiple Bus Masters	189
13.5.2	Registers	190
13.5.2.1	I2CS Register	190
13.5.2.2	I2CDAT Register	191
13.5.2.3	I2CTL Register	191
13.5.3	Sending Data	191
13.5.4	Receiving Data	191
13.6	EEPROM Boot Loader	192
14.	Timers/Counters and Serial Interface	193
14.1	Introduction	193
14.2	Timers/Counters	193
14.2.1	803x/805x Compatibility	193
14.2.2	Timers 0 and 1	193
14.2.2.1	Mode 0, 13 Bit Timer/Counter—Timer 0 and Timer 1	194
14.2.2.2	Mode 1, 16 Bit Timer/Counter — Timer 0 and Timer 1	195
14.2.2.3	Mode 2, 8 Bit Counter with Auto-Reload — Timer 0 and Timer 1	196
14.2.2.4	Mode 3, Two 8 Bit Counters — Timer 0 Only	196
14.2.3	Timer Rate Control	197
14.2.4	Timer 2	197
14.2.4.1	Timer 2 Mode Control	198

14.2.5	Timer 2: The 6 Bit Timer/Counter Mode	198
14.2.5.1	Timer 2 The 16 Bit Timer/Counter Mode with Capture	198
14.2.6	Timer 2: 16 Bit Timer/Counter Mode with Auto-Reload	199
14.2.7	Timer 2: Baud Rate Generator Mode	200
14.3	Serial Interface	201
14.3.1	803x/805x Compatibility	202
14.3.2	High-Speed Baud Rate Generator	202
14.3.3	Mode 0	202
14.3.4	Mode 1	205
14.3.4.1	Mode 1 Baud Rate	205
14.3.4.2	Mode 1 Transmit	207
14.3.5	Mode 1 Receive	207
14.3.6	Mode 2	208
14.3.6.1	Mode 2 Transmit	208
14.3.6.2	Mode 2 Receive	208
14.3.7	Mode 3	210
15.	Registers	211
15.1	Introduction	211
15.1.1	Example Register Format	211
15.1.2	Other Conventions	211
15.2	Special Function Registers	212
15.3	About SFRs	213
15.4	GPIF Waveform Memories	219
15.5	General Configuration Registers	220
15.6	Endpoint Configuration	233
15.6.11.1	IN Endpoints	248
15.6.11.2	OUT Endpoints	249
15.7	Interrupts	256
15.8	Input/Output Registers	275
15.9	ECC Control and Data Registers	283
15.9.1	ECC Features	283
15.9.2	ECC Implementation	283
15.9.3	ECC Check/Correct	284
15.10	UDMA CRC Registers	295
15.11	USB Control	297
15.12	Endpoints	305
15.13	General Programmable Interface	333
15.14	Endpoint Buffers	359
15.15	Synchronization Delay	366
Appendix A.	Descriptors for Full-Speed Mode	367
Appendix B.	Descriptors for High-Speed Mode	375
Appendix C.	Device Register Summary	383
Index		395

1. Introducing EZ-USB®



Introduction

The Universal Serial Bus (USB) has gained wide acceptance as the connection method of choice for PC peripherals. Equally successful in the Windows and Macintosh worlds, USB has delivered on its promises of easy attachment, an end to configuration hassles, and true plug-and-play operation.

The latest generation of the USB specification, 'USB 2.0', extends the original specification to include:

- A new 'high speed' 480 Mbps signaling rate, a 40× improvement over the USB 1.1 full speed rate of 12 Mbps
- Full backward and forward compatibility with USB 1.1 devices and cables
- A new hub architecture that can provide multiple 12 Mbps downstream ports for USB 1.1 devices

The Cypress Semiconductor EZ-USB® family offers single chip USB 2.0 peripherals with architecture designed to accommodate the higher data rates offered by USB 2.0. The EZ-USB FX2LP device (CY7C68013A/14A/15A/16A) supports both full and high speed modes. The EZ-USB FX1 device (CY7C64713) only supports the full speed mode. The term 'EZ-USB' refers generically to both EZ-USB FX2LP and EZ-USB FX1 devices.

This introductory chapter begins with a brief USB tutorial to put USB and EZ-USB terminology into context. The remainder of the chapter briefly outlines the EZ-USB architecture.

Note This Technical Reference Manual does not cover the CY7C646xx or AN21xx products. See the respective Technical Reference Manuals for these products for more information.

1.1 An Introduction to USB

Like a well designed automobile or appliance, a USB peripheral's outward simplicity hides internal complexity. There is a lot going on under the hood of a USB device.

- A USB device can be plugged in anytime, even while the PC is turned on
- When the PC detects that a USB device has been plugged in, it automatically interrogates the device to learn its capabilities and requirements. From this information, the PC automatically loads the device's driver into the operating system. When the device is unplugged, the operating system automatically logs it off and unloads its driver.
- USB devices do not use DIP switches, jumpers, or configuration programs. There is never an IRQ, DMA, memory, or I/O conflict with a USB device.
- USB expansion hubs make the bus simultaneously available to dozens of devices
- USB is fast enough for printers, hard disk drives, CD-quality audio, and scanners
- USB supports three speeds:
 - Low speed (1.5 Mbps), suitable for mice, keyboards and joysticks
 - Full speed (12 Mbps), for devices such as modems, speakers and scanners
 - High speed (480 Mbps), for devices such as hard disk drives, CD-ROMs, video cameras, and high resolution scanners

The Cypress Semiconductor EZ-USB family supports the high bandwidth offered by the USB 2.0 high-speed mode. The EZ-USB chips provide a highly-integrated solution for a USB peripheral device. The EZ-USB chips offer the following features:

- An integrated, high-performance CPU based on the industry-standard 8051 processor
- A soft (RAM-based) architecture that allows unlimited configuration and upgrades
- Full USB throughput. USB devices that use EZ-USB chips are not limited by number of endpoints, buffer sizes, or transfer speeds
- Automatic handling of most of the USB protocol, which simplifies code and accelerates the USB learning curve

1.2 The USB Specification

The *Universal Serial Bus Specification Version 2.0* is available on the Internet from the USB Implementers Forum, Inc., at <http://www.usb.org>. Published in April, 2000, the USB Specification is the work of a founding committee of seven industry heavyweights: Compaq, Hewlett-Packard, Lucent, Philips, Intel, Microsoft, and NEC. This impressive list of developers secures USB's position as the low- to high speed PC connection method of the future.

A glance at the USB Specification makes it immediately apparent that USB is not nearly as simple as the older serial or parallel ports. The USB Specification uses new terms like endpoint, isochronous, and enumeration, and finds new uses for old terms like configuration, interface, and interrupt. Woven into the USB fabric is a software abstraction model that deals with things such as pipes. The USB Specification also contains information about such details as connector types and wire colors.

1.3 Host is Master

This is a fundamental USB concept. There is exactly one master in a USB system: the host computer. **USB devices respond to host requests.** USB devices cannot send information among themselves, as they could if USB were a peer-to-peer topology.

However, there is one case where a USB device can initiate signaling without prompting from the host. After being put into a low-power 'suspend' mode by the host, a device can signal a 'remote wakeup'. This is the only case in which the USB device is the initiator; in all other cases, the host makes device requests and the device responds to them.

There is an excellent reason for this host-centric model. The USB architects were keenly aware of cost, and the best way to make low-cost peripherals is to put most of the 'smarts' into the host side, the PC. If USB had been defined as peer-to-peer, every USB device would have required more intelligence, raising cost.

1.4 USB Direction

Because the host is always the bus master, it is easy to remember USB direction: OUT means from the host to the device, and IN means from the device to the host. EZ-USB nomenclature uses this naming convention. For example, an endpoint that sends data to the host is an IN endpoint. This can be confusing at first, because the EZ-USB sends data to the host by loading an IN endpoint buffer. Likewise, the EZ-USB receives host data from an OUT endpoint buffer.

1.5 Tokens and PIDs

In this manual, you will read statements such as: "When the host sends an IN token...", or "The device responds with an ACK." What do these terms mean?

A USB transaction consists of data packets identified by special codes called Packet IDs or PIDs. A PID signifies what kind of packet is being transmitted. There are four PID types, shown in [Table 1-1](#).

Table 1-1. USB PIDS

PID Type	PID Name
Token	IN, OUT, SOF, SETUP
Data	DATA0, DATA1, DATA2, MDATA
Handshake	ACK, NAK, STALL, NYET
Special	PRE, ERR, SPLIT, PING

Bold type indicates PIDs introduced with USB 2.0

[Figure 1-1](#) illustrates a USB OUT transfer. Host traffic is shown in solid shading, while device traffic is shown cross-hatched. Packet 1 is an OUT token, indicated by the OUT PID. The OUT token signifies that data from the host is about to be transmitted over the bus. Packet 2 contains data, as indicated by the DATA1 PID. Packet 3 is a handshake packet, sent by the device using the ACK (acknowledge) PID to signify to the host that the device received the data error-free.

Continuing with [Figure 1-1](#), a second transaction begins with another OUT token 4, followed by more data 5, this time using the DATA0 PID. Finally, the device again indicates success by transmitting the ACK PID in a handshake packet 6.

When operating at full speed, every OUT transfer sends the OUT data, even when the device is busy and cannot accept the data. When operating at high speed, this slightly wasteful use of USB bandwidth is remedied by using the new 'Ping' PID. The host first sends a short PING token to an OUT endpoint, asking if there is room for OUT data in the peripheral device. Only when the PING is answered by an ACK does the host send the OUT token and data.

Figure 1-1. USB Packets

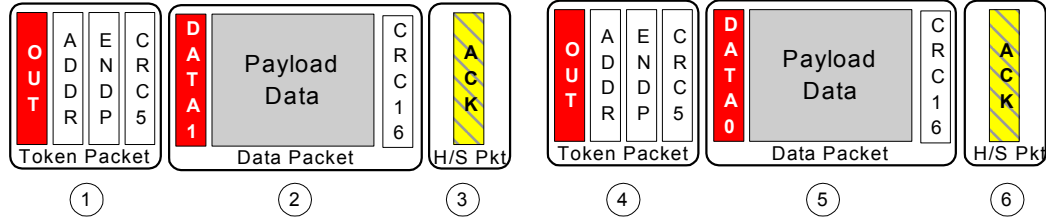

There are two DATA PIDs (DATA0 and DATA1) in Figure 1-1 because the USB architects took error correction very seriously. As mentioned previously, the ACK handshake is an indication to the host that the peripheral received data without error (the CRC portion of the packet is used to detect errors). But what if the handshake packet itself is garbled in transmission? To detect this, each side (host and device) maintains a 'data toggle' bit, which is toggled between data packet transfers. The state of this internal toggle bit is compared with the PID that arrives with the data, either DATA0 or DATA1. When sending data, the host or device sends alternating DATA0-DATA1 PIDs. By comparing the received Data PID with the state of its own internal toggle bit, the receiver can detect a corrupted handshake packet.

SETUP tokens are unique to CONTROL transfers. They preface eight bytes of data from which the peripheral decodes host Device Requests.

At full speed, SOF (Start of Frame) tokens occur once per millisecond. At high speed, each frame contains eight SOF tokens, each denoting a 125- μ s microframe.

Four handshake PIDs indicate the status of a USB transfer:

- ACK (Acknowledge) means 'success'; the data was received error-free.
- NAK (Negative Acknowledge) means 'busy, try again.' It is tempting to assume that NAK means 'error,' but it does not; a USB device indicates an error by not responding.
- STALL means that something unforeseen went wrong (probably as a result of miscommunication or lack of cooperation between the host and device software). A device sends the STALL handshake to indicate that it does not understand a device request, that something went wrong on the peripheral end, or that the host tried to access a resource that was not there. It is like HALT, but better, because USB provides a way to recover from a stall.
- NYET (Not Yet) has the same meaning as ACK — the data was received error-free — but also indicates that the endpoint is not yet ready to receive another OUT transfer. NYET PIDs occur only in high-speed mode.

A PRE (Preamble) PID precedes a low-speed (1.5 Mbps) USB transmission. The EZ-USB family supports full-speed (12 Mbps) and high-speed (480 Mbps) USB transfers only.

1.5.1 Receiving Data from the Host

To send data to a USB peripheral, the host issues an OUT token followed by the data. If the peripheral has space for the data and accepts it without error, it returns an ACK to the host. If it is busy, it sends a NAK. If it finds an error, it sends back nothing. For the latter two cases, the host re-sends the data at a later time.

1.5.2 Sending Data to the Host

A USB device never spontaneously sends data to the host. Either EZ-USB firmware or external logic can load data into an EZ-USB endpoint buffer and 'arm' it for transfer at any time. However, the data is not transmitted to the host until the host issues an IN request to the EZ-USB endpoint. If the host never sends the IN token, the data remains in the EZ-USB endpoint buffer indefinitely.

1.6 USB Frames

The USB host provides a time base to all USB devices by transmitting a start-of-frame (SOF) packet every millisecond. SOF packets include an 11 bit number which increments once per frame; the current frame number [0-2047] may be read from internal EZ-USB registers at any time.

At high speed (480 Mbps), each one-millisecond frame is divided into eight 125- μ s microframes, each of which is preceded by an SOF packet. The frame number still increments only once per millisecond, so each of those SOF packets contains the same frame number. To keep track of the current microframe number [0-7], the EZ-USB FX2LP provides a readable microframe counter.

The EZ-USB can generate an interrupt request whenever it receives an SOF (once every millisecond at full speed, or once every 125 μ s at high speed). This SOF interrupt can be used, for example, to service isochronous endpoint data.

1.7 USB Transfer Types

USB defines four transfer types. These match the requirements of different data types delivered over the bus.

1.7.1 Bulk Transfers

Figure 1-2. Two Bulk Transfers, IN and OUT

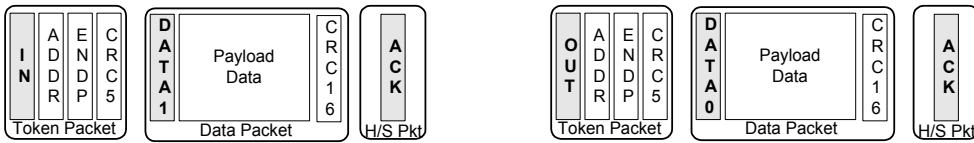

Bulk data is 'bursty,' traveling in packets of 8, 16, 32, or 64 bytes at full speed or 512 bytes at high speed. Bulk data has guaranteed accuracy, due to an automatic retry mechanism for erroneous data. The host schedules bulk packets when there is available bus time. Bulk transfers are typically used for printer, scanner, or modem data. Bulk data has built-in flow control provided by handshake packets.

1.7.2 Interrupt Transfers

Figure 1-3. An Interrupt Transfer

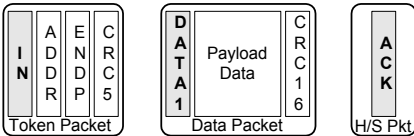

Interrupt data is like bulk data; it can have packet sizes of 1 through 64 bytes at full speed or up to 1024 bytes at high-speed. Interrupt endpoints have an associated polling interval that ensures they will be polled (receive an IN token) by the host on a regular basis.

1.7.3 Isochronous Transfers

Figure 1-4. An Isochronous Transfer



Isochronous data is time-critical and used to *stream* data like audio and video. An isochronous packet may contain up to 1023 bytes at full speed, or up to 1024 bytes at high speed.

Time of delivery is the most important requirement for isochronous data. In every USB frame, a certain amount of USB bandwidth is allocated to isochronous transfers. To lighten the overhead, isochronous transfers have no handshake (ACK/NAK/STALL/NYET), and no retries; error detection is limited to a 16 bit CRC.

Isochronous transfers do not use the data-toggle mechanism. Full-speed isochronous data uses only the DATA0 PID; high-speed isochronous data uses DATA0, DATA1, DATA2 and MDATA.

In full-speed mode, only one isochronous packet can be transferred per endpoint, per frame. In high-speed mode, up to three isochronous packets can be transferred per endpoint, per microframe. For more details, refer to the Isochronous Transfers discussion in Chapter 5 of the USB specification.

1.7.4 Control Transfers

Figure 1-5. A Control Transfer

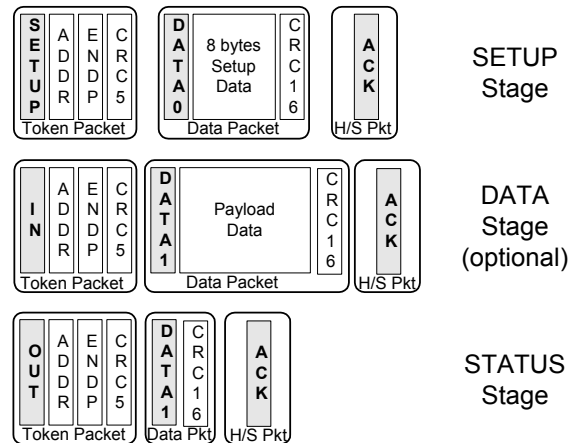

Control transfers configure and send commands to a device. Because they are so important, they employ the most extensive USB error checking. The host reserves a portion of each USB frame for Control transfers.

Control transfers consist of two or three stages. The SETUP stage contains eight bytes of USB CONTROL data. An optional DATA stage contains more data, if required. The STATUS (or handshake) stage allows the device to indicate successful completion of a CONTROL operation.

1.8 Enumeration

Your computer is ON. You plug in a USB device, and the Windows™ cursor switches to an hourglass and then back to a cursor. Magically, your device is connected and its Windows driver is loaded. Anyone who has installed a sound card into a PC and has had to configure countless jumpers, drivers, and I/O / Interrupt / DMA settings knows that a USB connection is miraculous. We've all heard about Plug and Play, but USB delivers the real thing.

How does all this happen automatically? Inside every USB device is a table of descriptors. This table is the sum total of the device's requirements and capabilities. When you plug into USB, the host goes through a sign on sequence:

1. The host sends a Get Descriptor-Device request to address zero (all USB devices must respond to address zero when first attached).
2. The device responds to the request by sending ID data back to the host to identify itself.
3. The host sends a Set Address request, which assigns a unique address to the just-attached device so it may be distinguished from the other devices connected to the bus.
4. The host sends more Get Descriptor requests, asking for additional device information. From this, it learns everything else about the device: number of endpoints, power requirements, required bus bandwidth, what driver to load, etc.

This sign-on process is called 'Enumeration'.

1.8.1 Full Speed/High Speed Detection

The USB Specification requires that high-speed (480 Mbits/sec) devices must also be capable of enumerating at full-speed (12 Mbps). In fact, all high-speed devices begin the enumeration process in full-speed mode; devices switch to high-speed operation only after the host and device have *agreed* to operate at high speed. The high-speed negotiation process occurs during USB reset, via the 'Chirp' protocol described in Chapter 7 of the USB Specification.

When connected to a full-speed host, the EZ-USB FX2LP enumerates as a full-speed device. When connected to a high-speed host, the EZ-USB FX2LP automatically switches to high-speed mode. The EZ-USB FX1 always enumerates as a full-speed device. Neither the EZ-USB FX2LP or the EZ-USB FX1 support the low-speed mode (1.5 Mbps).

1.9 The Serial Interface Engine

Figure 1-6. What the SIE Does

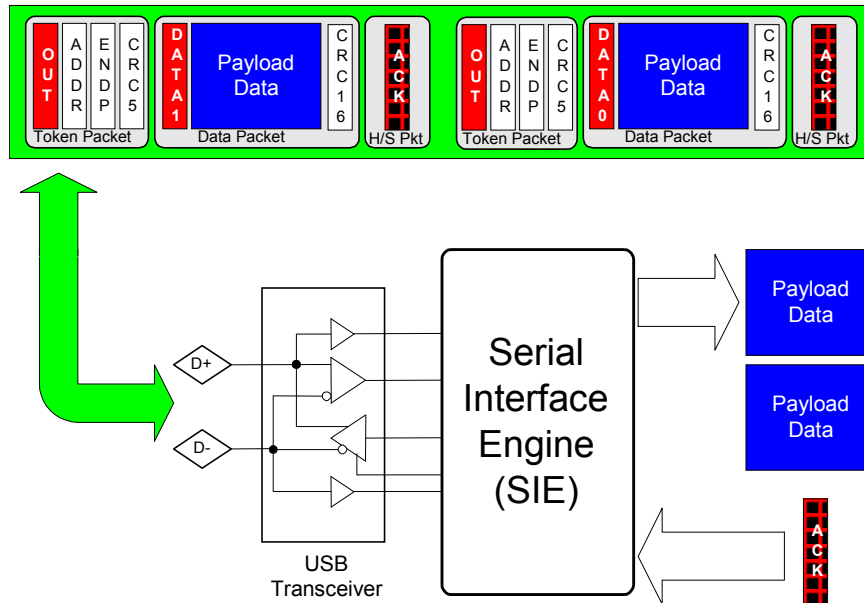

Every USB device has a Serial Interface Engine (SIE) which connects to the USB data lines (D+ and D-) and delivers data to and from the USB device. Figure 1-6 illustrates the SIE's role: it decodes the packet PIDs, performs error checking on the data using the transmitted CRC bits, and delivers payload data to the USB device.

Bulk transfers are 'asynchronous', meaning that they include a flow control mechanism using ACK and NAK

handshake PIDs. The SIE indicates busy to the host by sending a NAK handshake packet. When the USB device has successfully transferred the data, it commands the SIE to send an ACK handshake packet, indicating success. If the SIE encounters an error in the data, it automatically indicates no response instead of supplying a handshake PID. This instructs the host to retransmit the data at a later time.

To send data to the host, the SIE accepts bytes and control signals from the USB device, formats it for USB transfer, and sends it over D+ and D-. Because USB uses a self-clocking data format (NRZI), the SIE also inserts bits at appropriate places in the bit stream to guarantee a certain number of transitions in the serial data. This is called 'bit stuffing,' and is handled automatically by the EZ-USB's SIE.

One of the most important features of the EZ-USB family is that its configuration is *soft*. Instead of requiring ROM or other fixed memory, it contains internal program/data RAM which can be loaded over the USB. This makes modifications, specification revisions, and updates a snap.

The EZ-USB's 'smart' SIE performs much more than the basic functions shown in [Figure 1-6](#); it can perform a full enumeration by itself, which allows the EZ-USB to connect as a USB device and download code into its RAM while its CPU is held in reset. This added SIE functionality is also made available to the EZ-USB programmer, to make development easier and save code and processing time.

1.10 ReNumeration™

Because the EZ-USB's configuration is 'soft', one chip can take on the identities of multiple distinct USB devices.

When first plugged into USB, the EZ-USB enumerates automatically and downloads firmware and USB descriptor tables over the USB cable. Next, the EZ-USB enumerates again, this time as a device defined by the downloaded information. This patented two-step process, called ReNumeration™, happens instantly when the device is plugged in, with no hint that the initial download step has occurred.

Alternately, EZ-USB can also load its firmware from an external EEPROM.

The [Enumeration and ReNumeration™ chapter on page 51](#) describes these processes in detail.

1.11 EZ-USB Architecture

Figure 1-7. EZ-USB 56-Pin Package Simplified Block Diagram

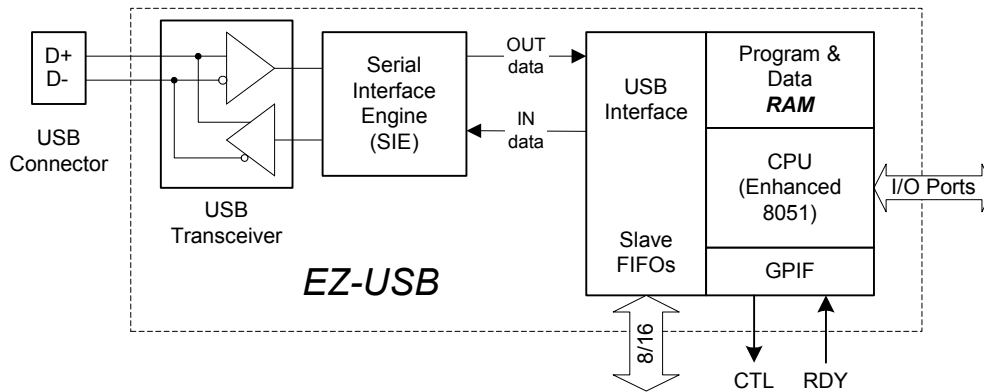

The EZ-USB packs all the intelligence required by a USB peripheral interface into a compact integrated circuit. As [Figure 1-7](#) illustrates, an integrated USB transceiver connects to the USB bus pins D+ and D-. A Serial Interface Engine (SIE) decodes and encodes the serial data and performs error correction, bit stuffing, and the other signaling-level tasks required by USB. Ultimately, the SIE transfers parallel data to and from the USB interface.

The EZ-USB FX2LP SIE operates at full-speed (12 Mbps) and high-speed (480 Mbps) rates. The EZ-USB FX1 SIE operates at the full-speed (12 Mbps) rate only. To accommodate the increased bandwidth of USB 2.0, the EZ-USB endpoint FIFOs and slave FIFOs (which interface to external

logic or processors) are unified to eliminate internal data transfer times.

The CPU is an enhanced 8051 with fast execution time and added features. It uses internal RAM for program and data storage.

The role of the CPU in a typical EZ-USB-based USB peripheral is two fold:

- It implements the high-level USB protocol by servicing host requests over the control endpoint (endpoint zero)
- It is available for general-purpose system use

The high-level USB protocol is not bandwidth-critical, so the EZ-USB's CPU is well-suited for handling host requests over

the control endpoint. However, the data rates offered by USB are too high for the CPU to process the USB data directly. For this reason, the CPU is not usually in the high-bandwidth data path between endpoint FIFOs and the external interface. **Note** Instead, the CPU simply configures the interface, then 'gets out of the way' while the unified EZ-USB FIFOs move the data directly between the USB and the external interface.

The FIFOs can be controlled by an external master, which either supplies a clock and clock-enable signals to operate synchronously, or strobe signals to operate asynchronously.

Alternately, the FIFOs can be controlled by an internal EZ-USB timing generator called the General Programmable Interface (GPIF). The GPIF serves as an 'internal' master, interfacing directly to the FIFOs and generating user-programmed control signals for the interface to external logic. Additionally, the GPIF can be made to wait for external events by sampling external signals on its RDY pins. The GPIF runs much faster than the FIFO data rate to give good programmable resolution for the timing signals. It can be clocked from either the internal EZ-USB clock or an externally supplied clock.

The EZ-USB's CPU is rich in features. Up to five I/O ports are available, as well as two USARTs, three counter/timers, and an extensive interrupt system. It runs at a clock rate of up to 48 MHz and uses four clocks per instruction cycle instead of the twelve required by a standard 8051.

The EZ-USB chip family uses an enhanced SIE/USB interface which simplifies EZ-USB code by implementing much of the USB protocol. In fact, the EZ-USB can function as a full USB device even without firmware.

All EZ-USB family chips operate at 3.3V. This simplifies the design of bus-powered USB devices, since the 5V power available at the USB connector (which the USB Specification allows to be as low as 4.4V) can drive a 3.3V regulator to deliver clean, isolated power to the EZ-USB chip.

EZ-USB is available in a 128-pin package which brings out the 8051 address bus, data bus, and control signals to allow connection of external memory and/or memory-mapped I/O. [Figure 1-8](#) is a block diagram for this package; The [Memory chapter on page 71](#), gives full details of the external-memory interface.

Figure 1-8. EZ-USB 128-Pin Package Simplified Block Diagram

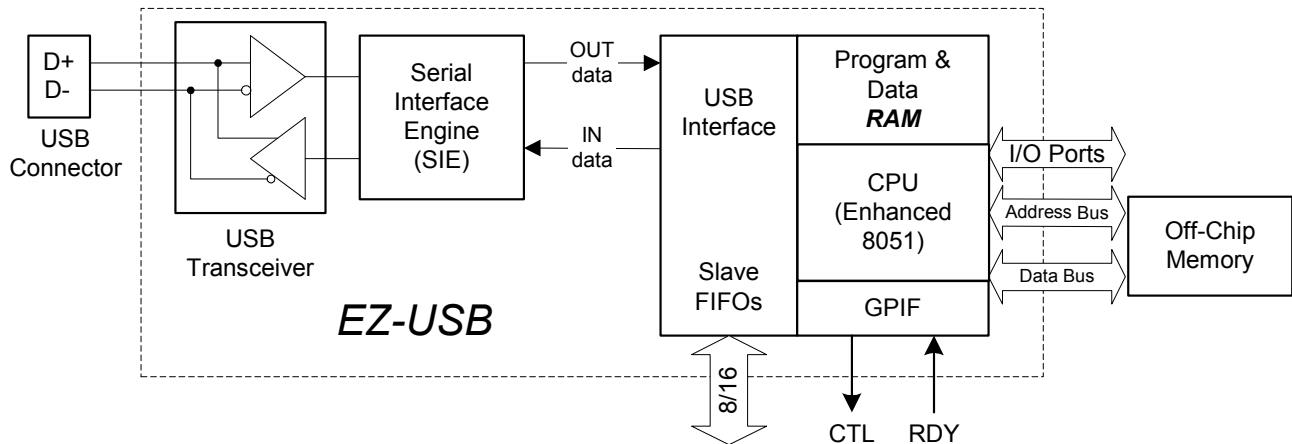

1.12 EZ-USB Feature Summary

The EZ-USB chips include the following features:

- Low power consumption enabling bus-powered designs
- For EZ-USB FX2LP, an on-chip 480 Mbps transceiver. For EZ-USB FX1, an on-chip 12 Mbps transceiver. Both devices contain a PLL and SIE—the entire USB physical layer (PHY).
- Double-, triple- and quad-buffered endpoint FIFOs accommodate the 480 Mbps USB data rate
- Built in, enhanced 8051 running at up to 48 MHz
 - Fully featured: 256 bytes of register RAM, two USARTs, three timers, two data pointers
 - Fast: four clocks (83.3 ns at 48 MHz) per instruction cycle
 - SFR access to control registers (including I/O ports) that require high speed
 - USB-vectored interrupts for low ISR latency
 - Used for USB housekeeping and control, not to move high-speed data
- ‘Soft’ operation—USB firmware can be downloaded over USB, eliminating the need for hard coded memory
- Four interface FIFOs that can be internally or externally clocked. The endpoint and interface FIFOs are unified to eliminate data transfer time between USB and external logic.
- General Programmable Interface (GPIF), a microcoded state machine which serves as a timing master for a glueless interface to the EZ-USB FIFOs
- ECC Generation based on the SmartMedia™ standard

The EZ-USB family offers single-chip USB 2.0 peripheral solutions. Unlike designs that use an external PHY, the EZ-USB integrates everything on one chip, eliminating costly high pin-count packages and the need to route high speed signals between chips.

1.13 EZ-USB Integrated Microprocessor

The EZ-USB’s CPU uses on-chip RAM as program and data memory. The [Memory chapter on page 71](#), describes the various internal/external memory options.

The CPU communicates with the SIE using a set of registers occupying on-chip RAM addresses 0xE500-0xE6FF. These registers are grouped and described by function in individual chapters of this reference manual and summarized in register order. [See chapter “Registers” on page 211](#).

The CPU has two duties. First, it participates in the protocol defined in the *Universal Serial Bus Specification Version 2.0, Chapter 9, USB Device Framework*. Thanks to the EZ-USB’s ‘smart’ SIE, the firmware associated with the USB

protocol is simplified, leaving code space and bandwidth available for the CPU’s primary duty—to help implement your device. On the device side, abundant input/output resources are available, including I/O ports, USARTs, and an I2C bus master controller. These resources are described in the [Input/Output chapter on page 181](#), and the [Timers/Counters and Serial Interface chapter on page 193](#).

It is important to recognize that the EZ-USB architecture is such that the CPU sets up and controls data transfers, but it normally does not participate in high bandwidth transfers. It is not in the data path; instead, the large data FIFOs that handle endpoint data connect directly to outside interfaces. To make the interface versatile, a programmable timing generator (GPIF, General Programmable Interface) can create user-programmed waveforms for high bandwidth transfers between the internal FIFOs and external logic.

The EZ-USB chips add eight interrupt sources to the standard 8051 interrupt system:

- INT2: USB Interrupt
- INT3: I2C Bus Interrupt
- INT4: FIFO/GPIF Interrupt
- INT4: External Interrupt 4
- INT5: External Interrupt 5
- INT6: External Interrupt 6
- USART1: USART1 Interrupt
- WAKEUP: USB Resume Interrupt

The EZ-USB chips provide 27 individual USB-interrupt sources which share the INT2 interrupt, and 14 individual FIFO/GPIF-interrupt sources which share the INT4 interrupt. To save the code and processing time which normally would be required to identify an individual interrupt source, the EZ-USB provides a second level of interrupt vectoring called Autovectoring. Each INT2 and INT4 interrupt source has its own autovector, so when an interrupt requires service, the proper ISR (interrupt service routine) is automatically invoked. The [Interrupts chapter on page 59](#) describes the EZ-USB interrupt system.

1.14 EZ-USB Block Diagram

Figure 1-9. EZ-USB Block Diagram

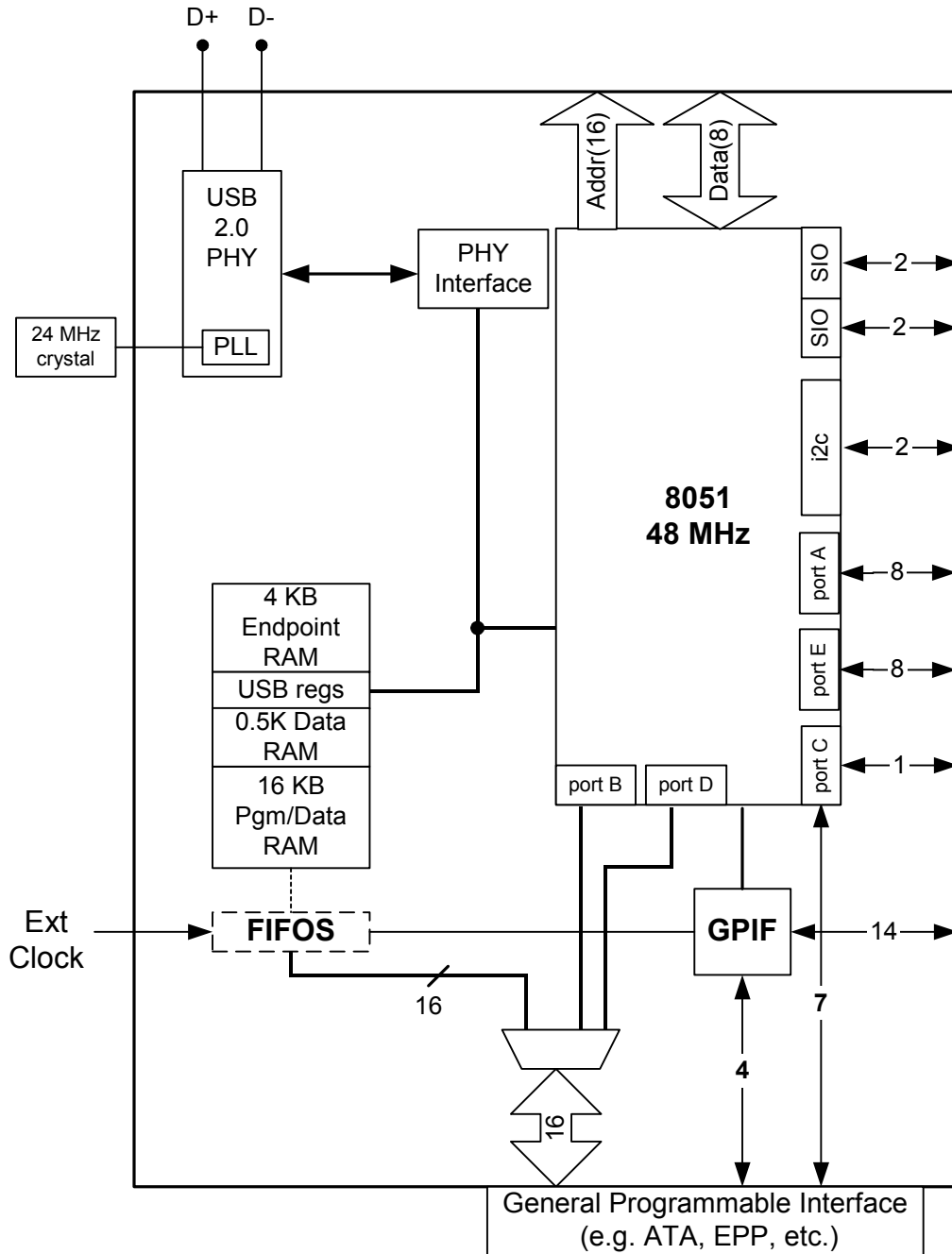

1.15 Packages

EZ-USB is available in five packages.

Figure 1-10. 56-Pin QFN, 56-Pin VFBGA, 56-Pin SSOP, 100-Pin, and 128-Pin EZ-USB Packages

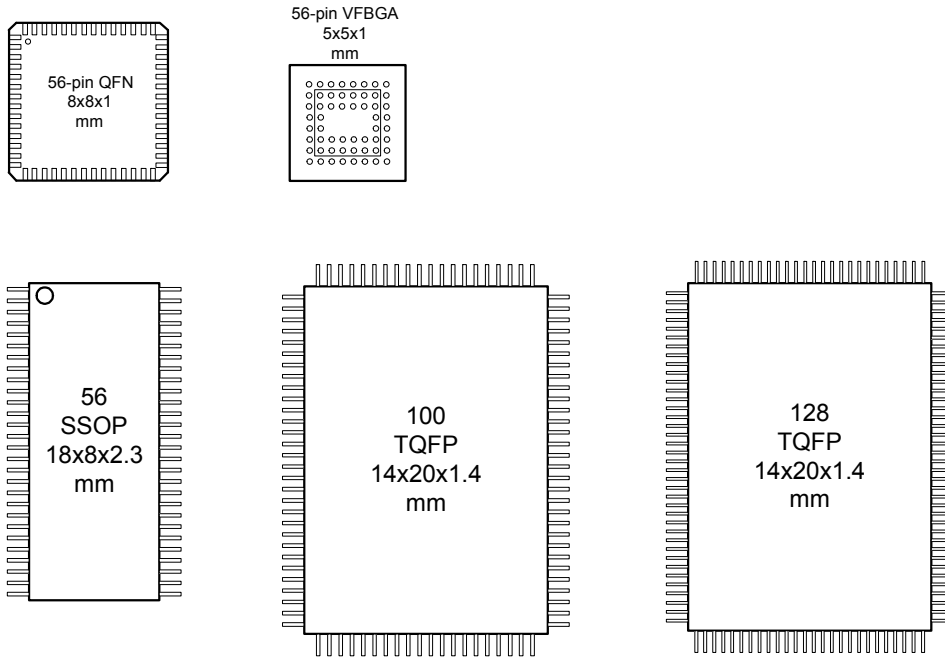

1.15.1 56-Pin Packages

Twenty-four general-purpose I/O pins (ports A, B, and D) are available. Sixteen of these I/O pins can be configured as the 16 bit data interface to the EZ-USB's internal high-speed 16-bit FIFOs, which can be used to implement low cost, high-performance interfaces such as ATAPI, UTOPIA, EPP, etc. The 56-pin packages have the following:

- Three 8-bit I/O ports: PORTA, PORTB, and PORTD
- I2C™ bus
- An 8- or 16-bit General Programmable Interface (GPIF) multiplexed onto PORTB and PORTD, with five non-multiplexed control signals
- Four 8- or 16-bit Slave FIFOs, with five non-multiplexed control signals and four or five control signals multiplexed with PORTA

1.15.2 CY7C68013A/14A and CY7C68015A/16A Differences

Two additional GPIO signals are available on the CY7C68015A and CY7C68016A to provide more flexibility when neither IFCLK or CLKOUT are needed in the 56-pin

package. The CY7C68015A and CY7C68016A is only available in the 56-pin package options.

Table 1-2. CY7C68013A/14A and CY7C68015A/16A Pin Differences

CY7C68013A/CY7C68014A	CY7C68015A/CY7C68016A
IFCLK	PE0
CLKOUT	PE1

1.15.3 100-Pin Package

The 100-pin package adds functionality to the 56-pin package:

- Two additional 8-bit I/O ports: PORTC and PORTE
- Seven additional GPIF Control (CTL) and Ready (RDY) signals
- Nine non-multiplexed peripheral signals (two USARTs, three timer inputs, INT4, and INT5#)
- Eight additional control signals multiplexed onto PORTE
- Nine GPIF address lines, multiplexed onto PORTC (eight) and PORTE (one)
- RD# and WR# signals which may be used as read and write strobes for PORTC

1.15.4 128-Pin Package

The 128-pin package adds the 8051 address and data buses and control signals. The RD#, PSEN#, and WR# strobes are standard 8051 control strobes, serving as read/write strobes for external memory attached to the 8051 address and data buses. The EZ-USB encodes the CS# and OE# signals to automatically exclude external access to memory spaces which exist on-chip, and optionally to combine off-chip data- and code-memory read accesses. The 128-pin package adds the following:

- 16-bit 8051 address bus
- 8-bit 8051 data bus
- Address/data bus control signals

1.15.5 Signals Available in the Five Packages

Three interface modes are available: Ports, GPIF Master, and Slave FIFO.

Figure 1-11 shows a logical diagram of the signals available in the five packages. The signals on the left edge of the diagram are common to all interface modes with the noted differences between the CY7C68013A and the CY7C68015A, while the signals on the right are specific to each mode. The interface mode is software-selectable via an internal mode register.

In 'Ports' mode, all the I/O pins are general-purpose I/O ports.

'GPIF master' mode uses the PORTB and PORTD pins as a 16-bit data interface to the four EZ-USB endpoint FIFOs EP2, EP4, EP6 and EP8. In this 'master' mode, the EZ-USB FIFOs are controlled by the internal GPIF, a programmable waveform generator that responds to FIFO status flags, drives timing signals using its CTL outputs, and waits for external conditions to be true on its RDY inputs. Note that only a subset of the GPIF signals (CTL0-2, RDY0-1) are available in the 56-pin packages, while the full set (CTL0-5, RDY0-5) is available in the 100- and 128-pin packages.

In the 'Slave FIFO' mode, external logic or an external processor interfaces directly to the EZ-USB endpoint FIFOs. In this mode, the GPIF is not active, since external logic has direct FIFO control. Therefore, the basic FIFO signals (flags, selectors, strobes) are brought out on EZ-USB pins. The external master can be asynchronous or synchronous, and it may supply its own independent clock to the EZ-USB interface.

The 100-pin package includes all the functionality of the 56-pin packages, and brings out the two additional I/O ports PORTC and PORTE as well as all the USART, Timer, Interrupt, and GPIF signals. The RD# and WR# pins function as PORTC strobes in the 100-pin package, and as expansion memory strobes in the 128-pin package.

The 128-pin package adds 28 pins to the 100-pin package to bring out the full 8051 expansion memory bus. This allows for the connection of external memory for applications that run at power-on and before connection to USB. The 128-pin package also provides the foundation for the Cypress EZ-USB Development Kit boards, in which code is developed using a debug monitor that runs in external RAM.

1.16 Package Diagrams

Figure 1-12. 128-Pin TQFP Pin Assignment

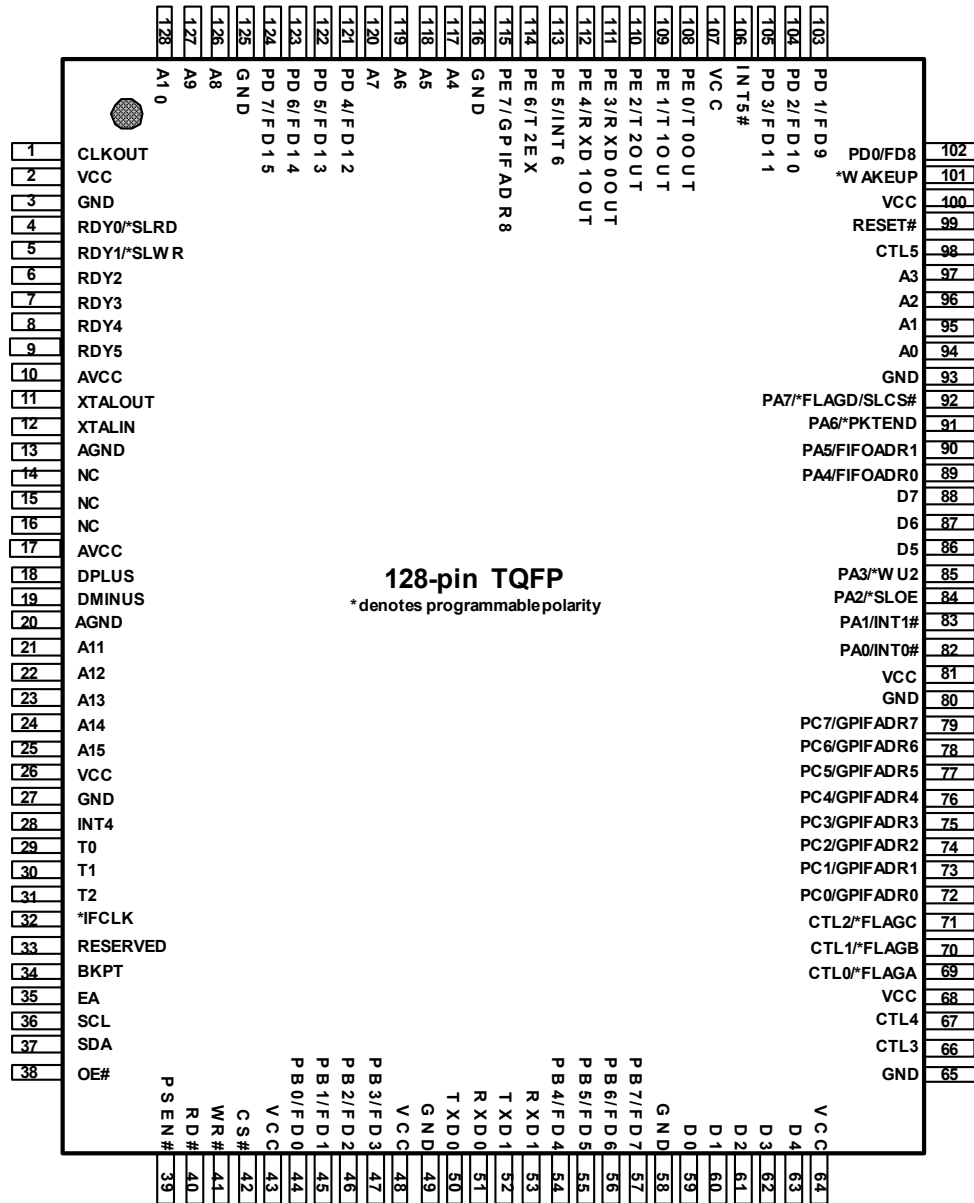

Figure 1-13. 100-Pin TQFP Pin Assignment

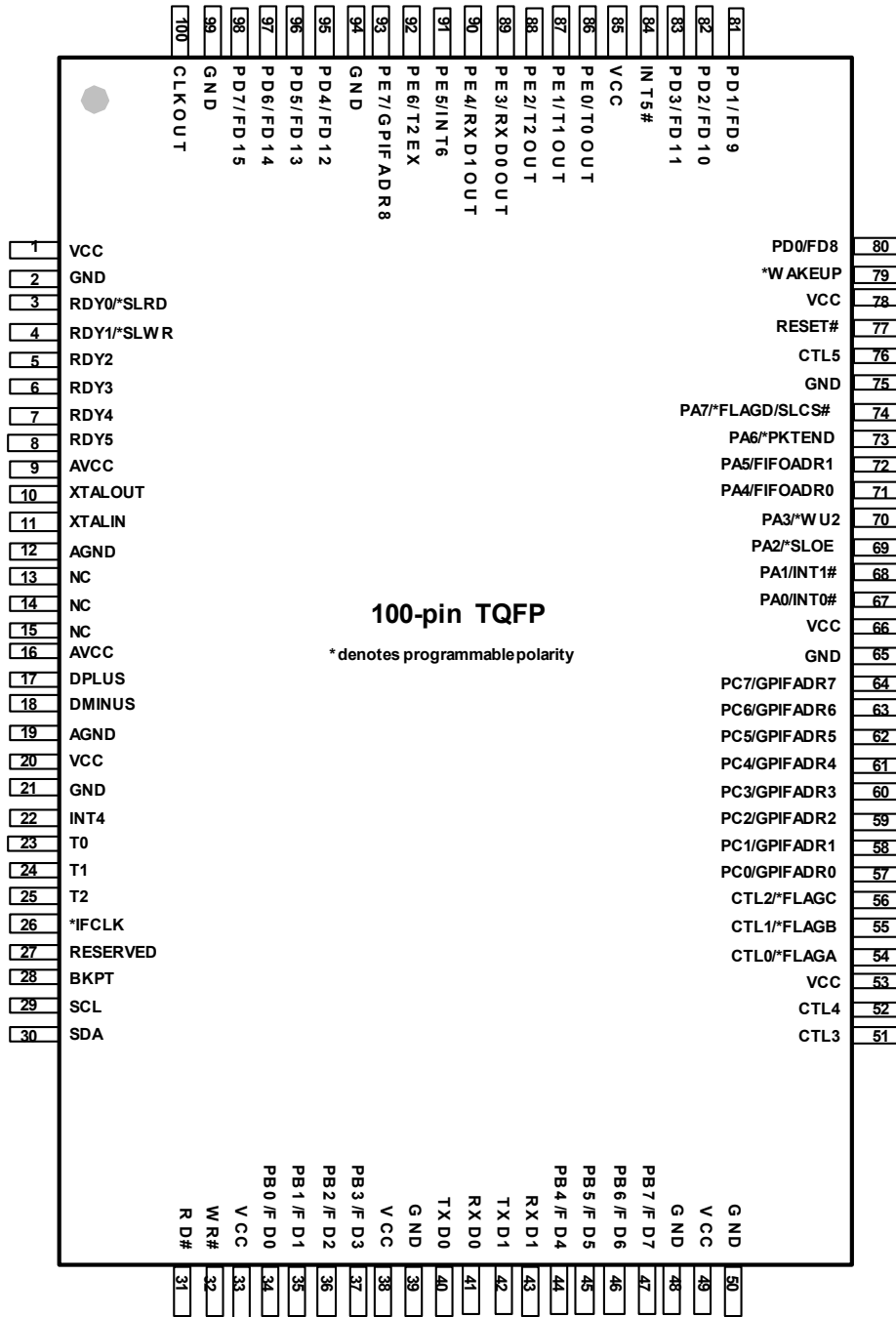
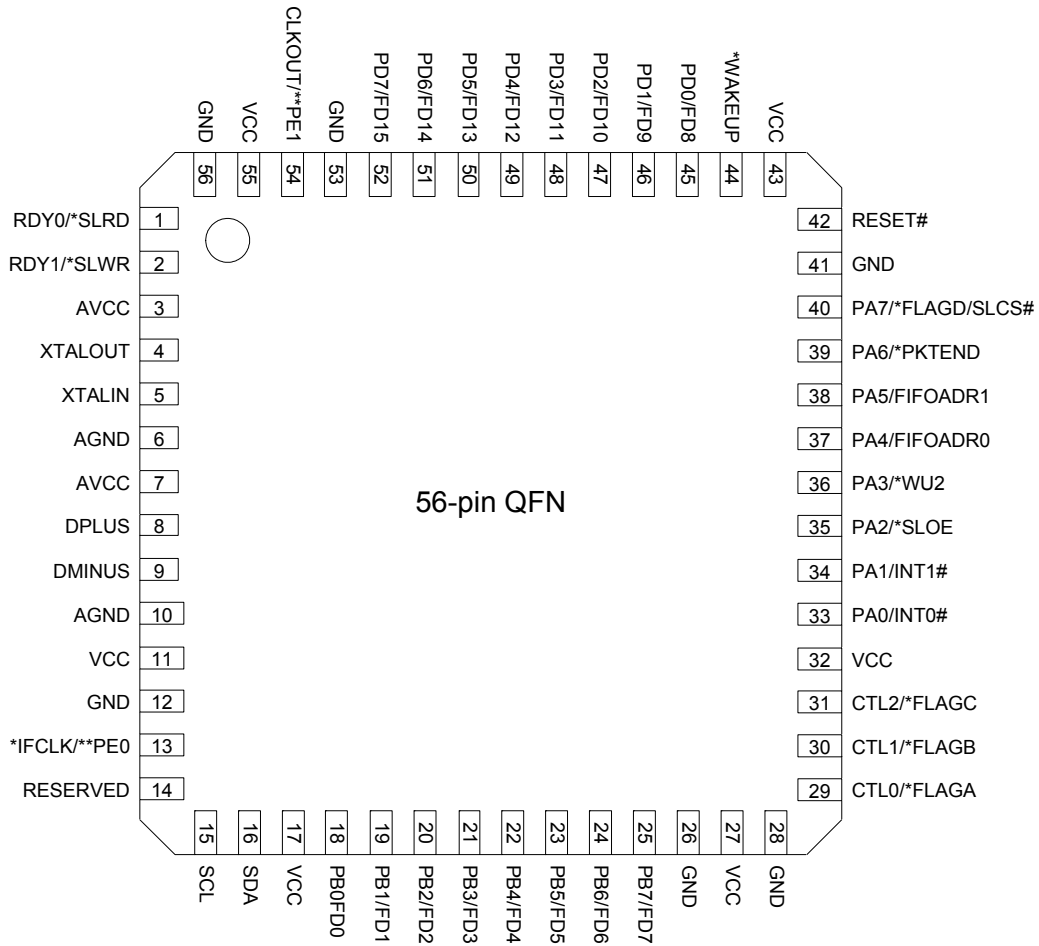

Figure 1-14. 56-Pin SSOP Pin Assignment

1	PD5/FD13	PD4/FD12	56
2	PD6/FD14	PD3/FD11	55
3	PD7/FD15	PD2/FD10	54
4	GND	PD1/FD9	53
5	CLKOUT	PD0/FD8	52
6	VCC	*WAKEUP	51
7	GND	VCC	50
8	RDY0/*SLRD	RESET#	49
9	RDY1/*SLWR	GND	48
10	AVCC	PA7/*FLAGD/SLCS#	47
11	XTALOUT	PA6/*PKTEND	46
12	XTALIN	PA5/FIFOADR1	45
13	AGND	PA4/FIFOADR0	44
14	AVCC	PA3/*WU2	43
15	DPLUS	PA2/*SLOE	42
16	DMINUS	PA1/INT1#	41
17	AGND	PA0/INT0#	40
18	VCC	VCC	39
19	GND	CTL2/*FLAGC	38
20	*IFCLK	CTL1/*FLAGB	37
21	RESERVED	CTL0/*FLAGA	36
22	SCL	GND	35
23	SDA	VCC	34
24	VCC	GND	33
25	PB0/FD0	PB7/FD7	32
26	PB1/FD1	PB6/FD6	31
27	PB2/FD2	PB5/FD5	30
28	PB3/FD3	PB4/FD4	29

* Programmable polarity

Figure 1-15. 56-Pin QFN Pin Assignment



* Programmable polarity
 ** CY7C68015A/16A pinout

Figure 1-16. 56-Pin VFBGA Pin Assignment

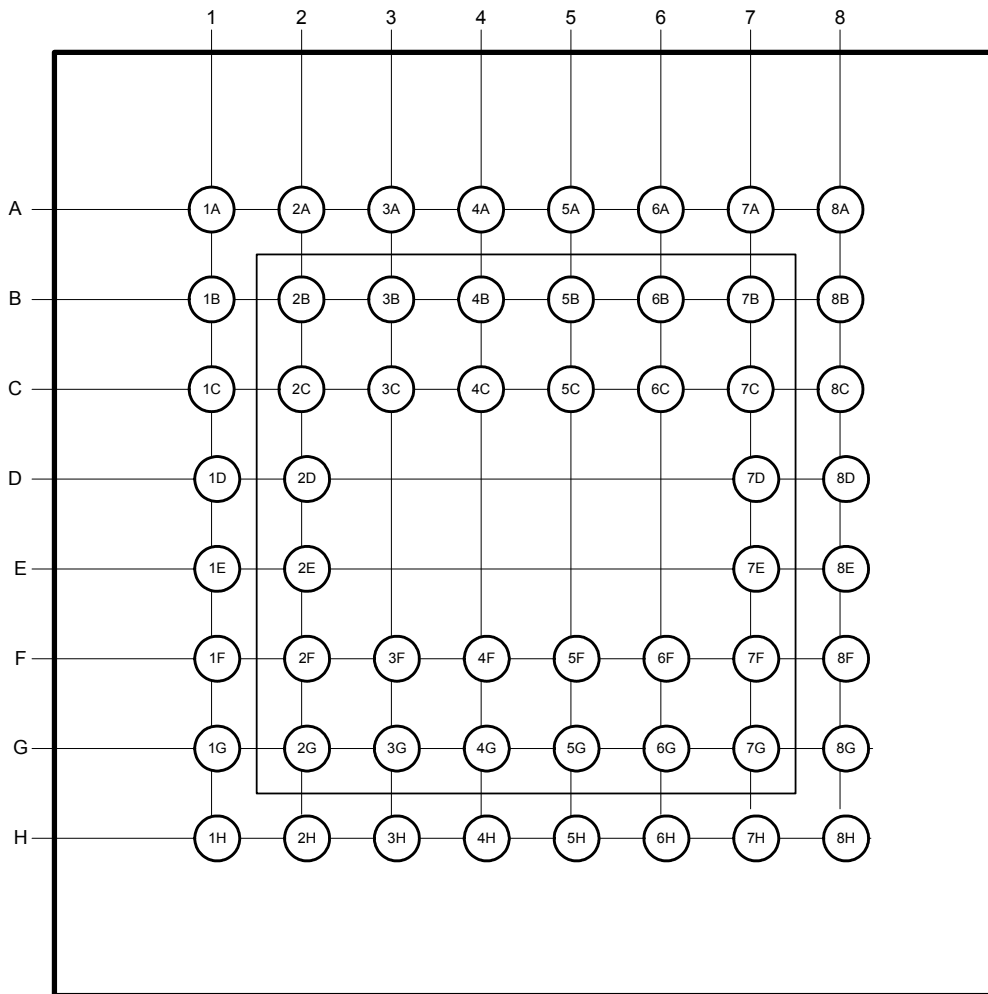

1.17 EZ-USB Endpoint Buffers

The USB Specification defines an endpoint as a source or sink of data. Since USB is a serial bus, a device endpoint is actually a FIFO which sequentially empties or fills with USB data bytes. The host selects a device endpoint by sending a 4-bit address and a direction bit. Therefore, USB can uniquely address 32 endpoints, IN0 through IN15 and OUT0 through OUT15.

From the EZ-USB's point of view, an endpoint is a buffer full of bytes received or held for transmission over the bus. The EZ-USB reads host data from an OUT endpoint buffer, and writes data for transmission to the host to an IN endpoint buffer.

EZ-USB contains three 64-byte endpoint buffers, plus 4 KB of buffer space that can be configured 12 ways, as indicated in Figure 1-17. The three 64-byte buffers are common to all configurations.

The three 64-byte buffers are designated EP0, EP1IN and EP1OUT. EP0 is the default CONTROL endpoint, a bidirectional endpoint that uses a single 64-byte buffer for both IN and OUT data. EZ-USB firmware reads or fills the EP0 buffer when the (optional) data stage of a CONTROL transfer is required.

Note The eight SETUP bytes in a CONTROL transfer do not appear in the 64-byte EP0 endpoint buffer. Instead, to simplify programming, the EZ-USB automatically stores the eight SETUP bytes in a separate buffer (SETUPDAT, at 0xE6B8-0xE6BF).

EP1IN and EP1OUT use separate 64 byte buffers. EZ-USB firmware can configure these endpoints as BULK or INTERRUPT. These endpoints, as well as EP0, are accessible only by EZ-USB firmware. This is in contrast to the large endpoint buffers EP2, EP4, EP6 and EP8, which are designed to move high bandwidth data directly on and off chip without firmware intervention.

Endpoints 2, 4, 6 and 8 are the large, high bandwidth, data moving endpoints. They can be configured in various ways to suit bandwidth requirements. The shaded boxes in Figure 1-17 enclose the buffers to indicate double, triple, or quad buffering. Double buffering means that one packet of data can be filling or emptying with USB data while another packet (from the same endpoint) is being serviced by external interface logic. Triple buffering adds a third packet buffer to the pool, which can be used by either side (USB or interface) as needed. Quad buffering adds a fourth packet buffer. Multiple buffering can significantly improve USB bandwidth performance when the data supplying and consuming rates are similar, but bursty; it smooths out the bursts, reducing or eliminating the need for one side to wait for the other.

Figure 1-17. EZ-USB Endpoint Buffers

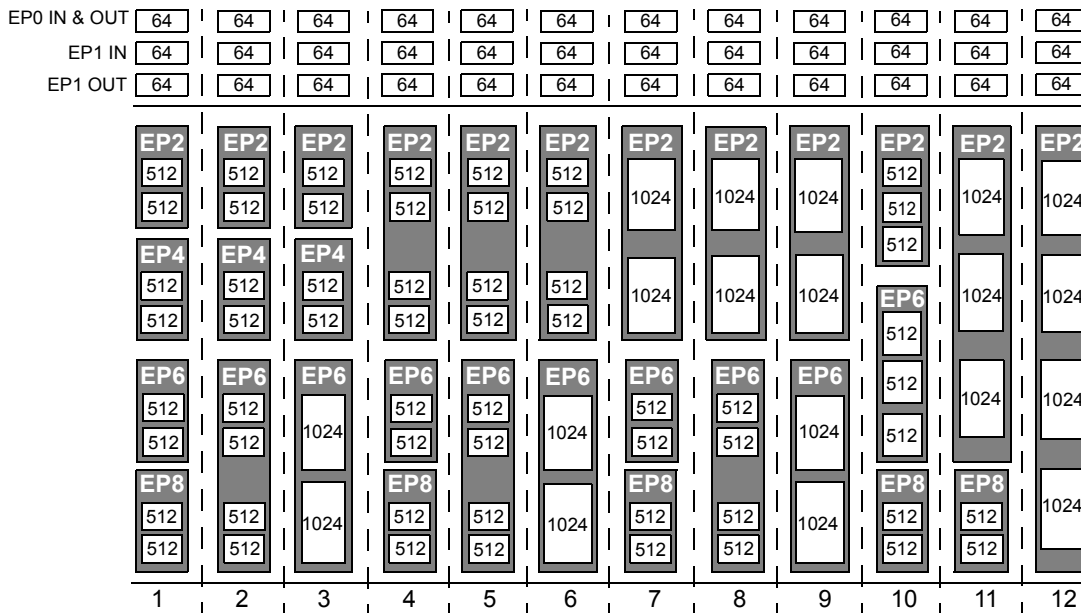

Endpoints 2, 4, 6 and 8 can be configured using the choices shown in [Table 1-3](#).

Table 1-3. Endpoint 2, 4, 6, and 8 Configuration Choices

Characteristic	Choices
Direction	IN, OUT
Type	Bulk, Interrupt, Isochronous
Buffering	Double, Triple, Quad

When the EZ-USB operates at full speed (12 Mbps), some or all of the endpoint buffer bytes shown in [Figure 1-17](#) may be employed, depending on endpoint type.

Note Regardless of the physical buffer size, each endpoint buffer accommodates only one full-speed packet.

For example, if EP2 is used as a full-speed BULK endpoint, the maximum number of bytes (maxPacketSize) it can accommodate is 64, even though the physical buffer size is 512 or 1024 bytes (it makes sense, therefore, to configure full-speed BULK endpoints as 512 bytes rather than 1024, so that fewer unused bytes are wasted). An ISOCHRONOUS full-speed endpoint, on the other hand, could fully use either a 512- or 1024-byte buffer.

1.18 External FIFO Interface

The large data FIFOs (endpoints 2, 4, 6 and 8) in the EZ-USB are designed to move high-speed (480 Mbps) USB data on and off chip without introducing any bandwidth bottlenecks. They accomplish this goal by implementing the following features:

1. Direct interface with outside logic, with the EZ-USB's CPU out of the data path.
2. 'Quantum FIFO' architecture instantaneously moves (commits) packets between the USB and the FIFOs.
3. Versatile interfaces: Slave FIFO (external master) or GPIF (internal master), synchronous or asynchronous clocking, internal or external clocks, etc.

The firmware sets switches to configure the outside FIFO interface, and then generally does not participate in moving the data into and out of the FIFOs.

To understand the 'Quantum FIFO', it is necessary to refer to two data domains, the USB domain and the Interface domain. Each domain is independent, allowing different clocks and logic to handle its data.

The USB domain is serviced by the SIE, which receives and delivers FIFO data packets over the two-wire USB bus. The USB domain is clocked using a reference derived from the 24 MHz crystal attached to the EZ-USB chip.

The Interface domain loads and unloads the endpoint FIFOs. An external device such as a DSP or ASIC can supply its own clock to the FIFO interface, or the EZ-USB's

internal interface clock (IFCLK) can be supplied to the interface.

The classic solution to the problem of reconciling two different and independent clocks is to use a FIFO. The EZ-USB's FIFOs have an unusual property: They are Quantum FIFOs, which means that data is committed to the FIFOs in USB-size packets, rather than one byte at a time. This is invisible to the outside interface, since it services the FIFOs just like any ordinary FIFO (i.e., by checking full and empty flags). The only minor difference is that when an empty flag goes from 1 (empty) to 0 (not empty), the number of bytes in the FIFO jumps to a USB packet size, rather than just one byte.

EZ-USB Quantum FIFOs may be moved between data domains almost instantaneously. The Quantum nature of the FIFOs also simplifies error recovery. If endpoint data were continuously clocked into an interface FIFO, some of the packet data might have already been clocked out by the time an error is detected at the end of a USB packet. By switching FIFO data between the domains in USB-packet-size blocks, each USB packet can be error-checked (and retried, if necessary) before it's committed to the other domain.

[Figure 1-18 on page 32](#) and [Figure 1-19 on page 33](#) illustrate the two methods by which external logic interfaces to the endpoint FIFOs EP2, EP4, EP6 and EP8.

Figure 1-18. EZ-USB FIFOs in Slave FIFO Mode

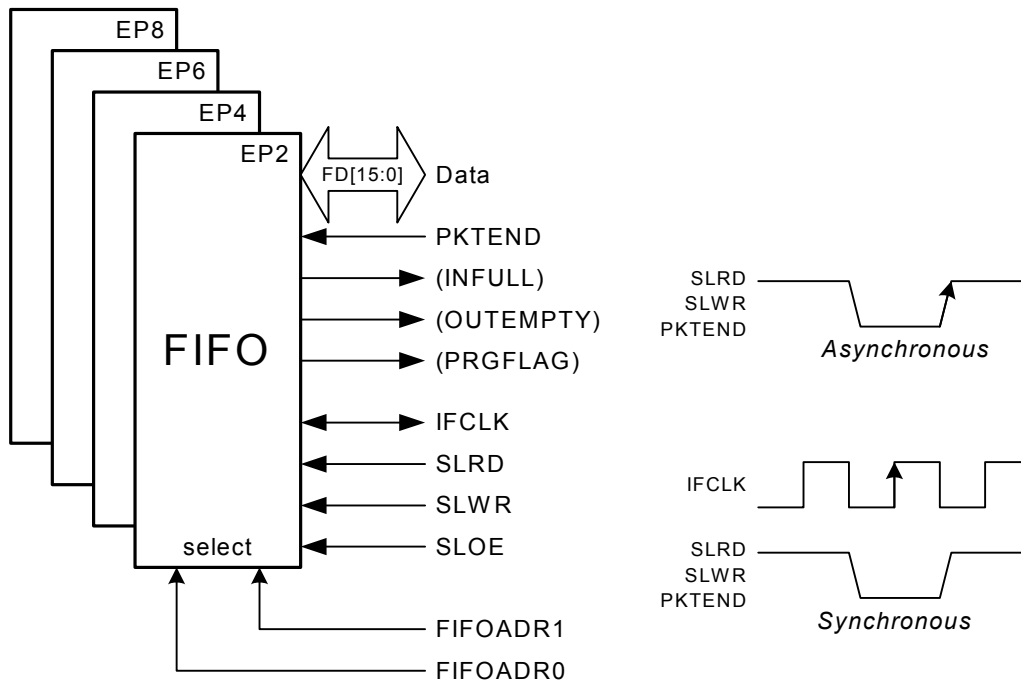
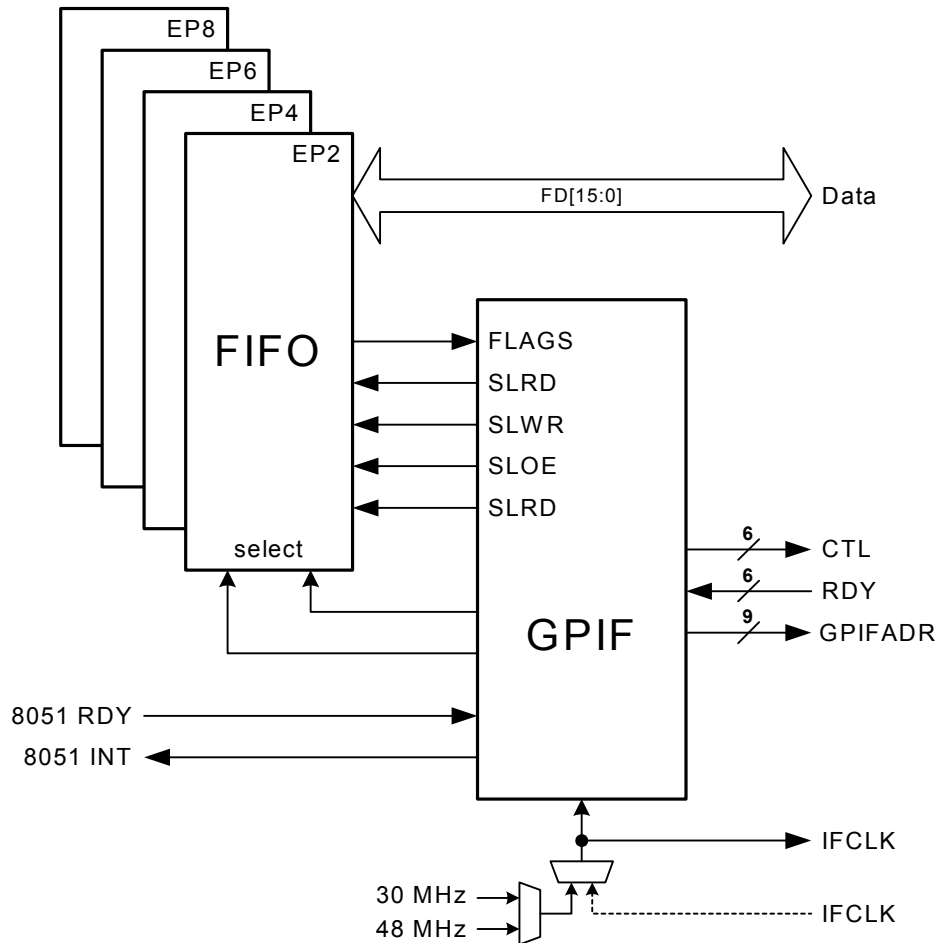

Figure 1-18 illustrates the outside-world view of the EZ-USB data FIFOs configured as Slave FIFOs. The outside logic supplies a clock, responds to the FIFO flags, and clocks FIFO data in and out using the strobe signals. Optionally, the outside logic may use the internal EZ-USB Interface Clock (IFCLK) as its reference clock.

Three FIFO flags are shown in parentheses in Figure 1-18 because they actually are called FLAGA-FLAGD in the pin diagram (there are four flag pins). Using configuration bits, various FIFO flags can be assigned to these general-purpose flag pins. The names shown in parentheses illustrate typical uses for these configurable flags. The Programmable Level Flag (PRGFLAG) can be set to any value to indicate degrees of FIFO 'fullness'. The outside interface selects one of the four FIFOs using the FIFOADR pins, and then clocks the 16-bit FIFO data using the SLRD (Slave Read) and SLWR (Slave Write) signals. PKTEND is used to dispatch a short (less than max packet size) IN packet to USB.

Figure 1-19. EZ-USB FIFOs in GPIF Master Mode



External systems that connect to the EZ-USB FIFOs must provide control circuitry to select FIFOs, check flags, clock data, etc. The EZ-USB contains a sophisticated control unit (the General Programmable Interface, or GPIF) which can replace this external logic. In the GPIF Master FIFO mode, (Figure 1-19), the GPIF reads the FIFO flags, controls the FIFO strobes, and presents a user-customizable interface to the outside world. The GPIF runs at a very high speed (up to 48 MHz clock rate) so that it can develop high-resolution control waveforms. It can be clocked from one of two internal sources (30 or 48 MHz) or from an external clock.

Control (CTL) signals are programmable waveform outputs, and ready (RDY) signals are input pins that can be tested for conditions that cause the GPIF to pause and resume operation, implementing 'wait states'. GPIFADR pins present a 9-bit address to the interface that may be incremented as data is transferred. The 8051 INT signal is a 'hook' that can signal the EZ-USB's CPU in the middle of a transaction; GPIF operation resumes once the CPU asserts its own 8051 RDY signal. This 'hook' permits great flexibility in the generation of GPIF waveforms.

1.19 EZ-USB Product Family

The EZ-USB family is available in various pinouts and operational modes to serve different system requirements and costs.

Table 1-4. EZ-USB FX2LP Part Numbers (Full Speed and High Speed)

Part Number	Package	RAM	ISO Support	I/O	Bus Width	Data/Address Bus
Ideal for battery powered applications						
CY7C68014A-128AXC	128-pin TQFP – Pb-Free	16K Bytes	Yes	40	16/8 Bit	8051 Address/Data Bus
CY7C68014A-100AXC	100-pin TQFP – Pb-Free	16K Bytes	Yes	40	–	No
CY7C68014A-56PVXC	56-pin SSOP – Pb-Free	16K Bytes	Yes	24	–	No
CY7C68014A-56LFXC	56-pin QFN – Pb-Free	16K Bytes	Yes	24	–	No
CY7C68016A-56LFXC	56-pin QFN – Pb-Free	16K Bytes	Yes	26	–	No
Ideal for nonbattery powered applications						
CY7C68013A-128AXC	128-pin TQFP – Pb-Free	16K Bytes	Yes	40	16/8 Bit	8051 Address/Data Bus
CY7C68013A-128AXI	128-pin TQFP – Pb-Free (Industrial)	16K Bytes	Yes	40	16/8 Bit	8051 Address/Data Bus
CY7C68013A-100AXC	100-pin TQFP – Pb-Free	16K Bytes	Yes	40	–	No
CY7C68013A-100AXI	100-pin TQFP – Pb-Free (Industrial)	16K Bytes	Yes	40	–	No
CY7C68013A-56PVXC	56-pin SSOP – Pb-Free	16K Bytes	Yes	24	–	No
CY7C68013A-56PVXI	56-pin SSOP – Pb-Free (Industrial)	16K Bytes	Yes	24	–	No
CY7C68013A-56LFXC	56-pin QFN – Pb-Free	16K Bytes	Yes	24	–	No
CY7C68013A-56LFXI	56-pin QFN – Pb-Free (Industrial)	16K Bytes	Yes	24	–	No
CY7C68015A-56LFXC	56-pin QFN – Pb-Free	16K Bytes	Yes	26	–	No
CY7C68013A-56BAXC	56 VFBGA – Pb-Free	16K Bytes	Yes	24	–	No

Table 1-5. EZ-USB FX1 Part Numbers (Full Speed Only)

Part Number	Package	RAM	ISO Support	I/O	Bus Width	Data/Address Bus
Ideal for nonbattery powered applications						
CY7C64713-128AXC	128-pin TQFP – Pb-Free	16K Bytes	Yes	40	16/8 Bit	8051 Address/Data Bus
CY7C64713-100AXC	100-pin TQFP – Pb-Free	16K Bytes	Yes	40	–	No
CY7C64713-56LFXC	56-pin QFN – Pb-Free	16K Bytes	Yes	24	–	No

1.20 Document History

This section is a chronicle of the *EZ-USB Technical Reference Manual* for the EZ-USB FX2LP and EX-USB FX1 devices.

EZ-USB Technical Reference Manual History

Release Date	Version	Originator	Description of Change
01/31/2003	1.4	ARI	This manual has gone through several versions and is based on the EZ-USB FX2. The most recent printing of this manual is Version 1.4.
09/11/2006	2.0	ARI	The information in this manual is identical to version 1.4, but a new template was implemented as part of the new corporate standard.
N/A	2.1	ARI	The information in this manual is the same as the previous versions but it has a new Document History section and it has an index. This version was not released.
03/19/2007	**	ARI	This manual is a new document to the Cypress Document Control (Revision **) system; it is the same as version 2.1. This document has been issued the document number 001-13670
02/21/2008	*A	CMCC	Delete references to CY7C64714. Remove T0OUT and T1OUT from 56-pin QFN. Add industrial part numbers to product list. Change FIFORESET procedures to NAK all while resetting FIFO to avoid potential race condition. Fix general typos and text formatting.
06/15/2009	*B	DSG	Updated EP2 and EP6 byte capacity in Section 15.12.4. Corrected the Notes entry for E611 to Default: BULK IN 64 in Appendix C, Pg 338. Corrected the Appendix A title in the Contents Section. Updated the USBCS (USB Control and Status) register address 7FD6 to E680 in section 6.4. Modified Fig 10-37 to remove the additional AUTOIN = 1 from the diagram in Section 10.4.6. Updated Bit 1 description for INT4 in Section 15.7.12. Corrected AUTOOUT setting in point 5 of section 9.3.2. Corrected bit descriptions in section 15.12.5 through 15.12.8. Added sections 9.3.12 and 9.3.13. Reformatted to match current template.
09/08/2010	*C	DSG	Changed 4x to 2x in section 9.2.7. Added bit 7 functionality to section 3.5 EEPROM Configuration Byte. Changed FIFORESET = 0x86 to 0x88 in Figure 9-40. Added Contents Overview. Updated Note in section 8.4. Added Note in section 15.6.3. Updated Bit 3 AUTOIN Description in section 15.6.4. Updated Bit 2 BERR Description in Section 13.5.2.1 and 15.8.4.
02/04/2011	*D	ODC	Fixed Figure 10-18



2. Endpoint Zero



2.1 Introduction

Endpoint zero has special significance in a USB system. It is a CONTROL endpoint, and it is required by every USB device. The USB host uses special SETUP tokens to signal transfers that deal with device control; only CONTROL endpoints accept these special tokens.

The USB host sends a suite of standard device requests over endpoint zero. These standard requests are fully defined in Chapter 9 of the *USB Specification*. This chapter describes how the EZ-USB chip handles endpoint zero requests.

The EZ-USB provides extensive hardware support for handling endpoint-zero operations; this chapter describes those operations and the EZ-USB resources that simplify the firmware which handles them.

Endpoint zero is the only CONTROL endpoint supported by the EZ-USB. CONTROL endpoints are bidirectional, so the EZ-USB provides a single 64-byte buffer, EP0BUF, which firmware handles exactly like a bulk endpoint buffer for the data stages of a CONTROL transfer. A second 8-byte buffer called SETUPDAT, which is unique to endpoint zero, holds data that arrives in the SETUP stage of a CONTROL transfer. This relieves the EZ-USB firmware of the burden of tracking the three CONTROL transfer phases (SETUP, DATA, and STATUS). The EZ-USB also generates separate interrupt requests for the various transfer phases, further simplifying code.

Endpoint zero is always enabled and accessible by the USB host.

2.2 Control Endpoint EP0

Endpoint zero accepts a special SETUP packet, which contains an 8-byte data structure that provides host information about the CONTROL transaction. CONTROL transfers include a final STATUS phase, constructed from standard PIDs (IN/OUT, DATA1, and ACK/NAK).

Some CONTROL transactions include all required data in their 8-byte SETUP Data packet. Other CONTROL transactions require more OUT data than fit into the eight bytes, or require IN data from the device. These transactions use standard bulk-like transfers to move the data. Note in [Figure 2-1 on page 38](#) that the DATA Stage looks exactly like a bulk transfer. As with BULK endpoints, the endpoint zero byte count registers must be loaded to ACK each data transfer stage of a CONTROL transfer.

The STATUS stage consists of an empty data packet with the opposite direction of the data stage, or an IN if there was no data stage. This empty data packet gives the device a chance to ACK or NAK the entire CONTROL transfer.

The HSNACK bit holds off the completion of a CONTROL transfer until the device has had time to respond to a request. For example, if the host issues a Set_Interface Request, the EZ-USB firmware performs various housekeeping chores such as adjusting internal modes and re-initializing endpoints. During this time, the host issues handshake (STATUS stage) packets to which the EZ-USB automatically responds with NAKs, indicating 'busy.' When the firmware completes its housekeeping operations, it clears the HSNACK bit (by writing '1' to it), which instructs the EZ-USB to ACK the STATUS stage, terminating the transfer. This handshake prevents the host from attempting to use an interface before it is fully configured.

To perform an endpoint stall for the DATA or STATUS stage of an endpoint zero transfer (the SETUP stage can never stall), firmware must set both the STALL and HSNACK bits for endpoint zero.

Figure 2-1. A USB Control Transfer (With Data Stage)

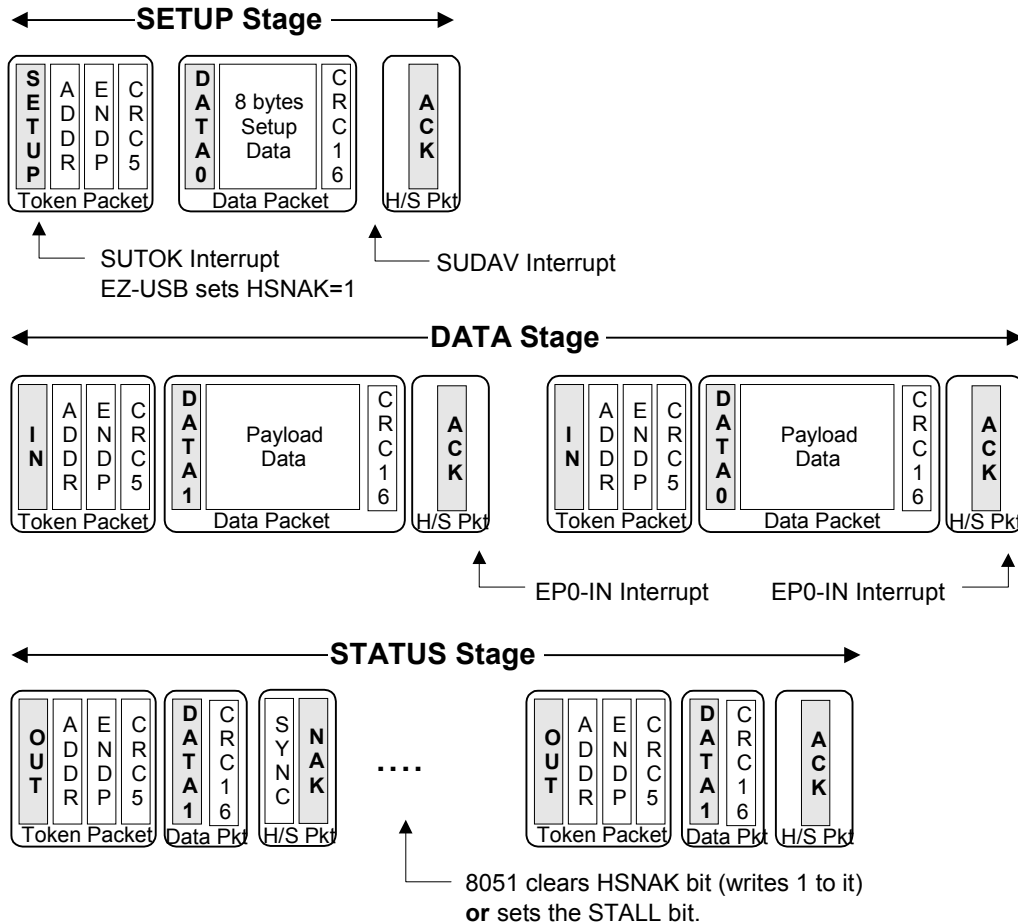

Some CONTROL transfers do not have a DATA stage. Therefore, the code that processes the SETUP data should check the length field in the SETUP data (in the 8-byte buffer at SETUPDAT) and arm endpoint zero for the DATA phase (by loading EP0BCH:L) only if the length field is non-zero.

Two interrupts provide notification that a SETUP packet has arrived, as shown in Figure 2-2.

Figure 2-2. Two Interrupts Associated with EP0 CONTROL Transfers

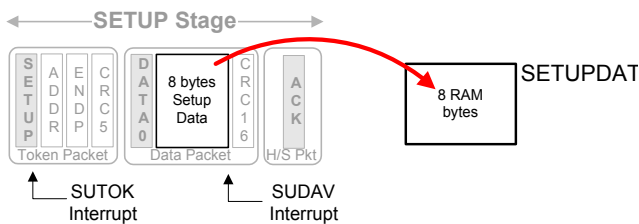

The EZ-USB asserts the SUTOK (Setup Token) interrupt request when it detects the SETUP token at the beginning of a CONTROL transfer. This interrupt is normally used for debug only.

The EZ-USB asserts the SUDAV (Setup Data Available) interrupt request when the eight bytes of SETUP data have been received error-free and transferred to the SETUPDAT buffer. The EZ-USB automatically takes care of any retries if it finds errors in the SETUP data. These two interrupt request bits must be cleared by firmware.

Firmware responds to the SUDAV interrupt request by either directly inspecting the eight bytes at SETUPDAT or by transferring them to a local buffer for further processing. Servicing the SETUP data should be a high priority, since the USB Specification stipulates that CONTROL transfers must always be accepted and never NAK'd. It is possible, therefore, that a CONTROL transfer could arrive while the firmware is still servicing a previous one. In this case, the earlier CONTROL transfer service should be aborted and the new one serviced. The SUTOK interrupt gives advance warning that a new CONTROL transfer is about to overwrite the eight SETUPDAT bytes.

Figure 2-3. Registers Associated with EP0 Control Transfers

Registers Associated with Endpoint Zero For handling SETUP transactions

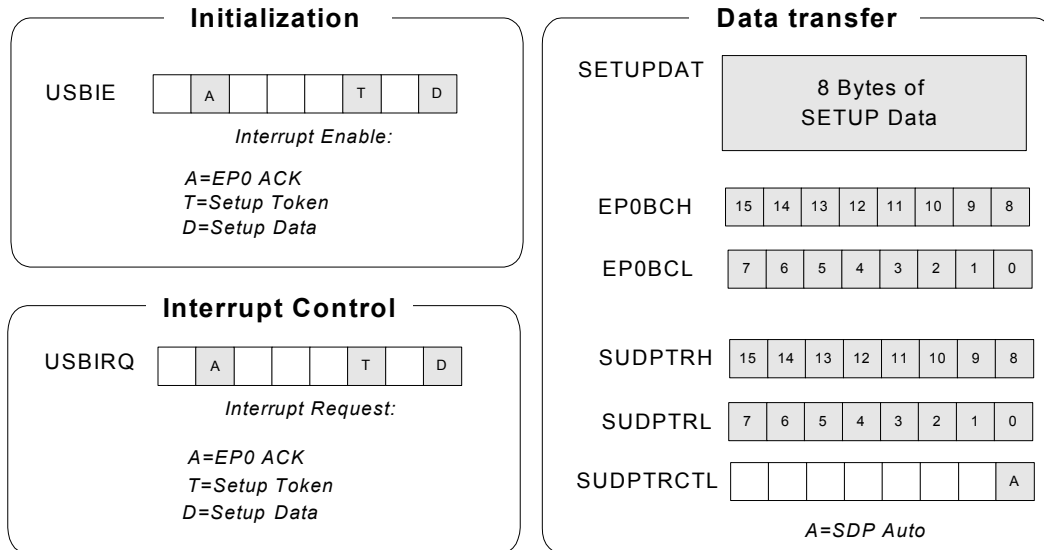

If the firmware stalls endpoint zero (by setting the STALL and HSNACK bits to 1), the EZ-USB automatically clears the stall bit when the next SETUP token arrives.

Like all EZ-USB interrupt requests, the SUTOK and SUDAV bits can be directly tested and cleared by the firmware (cleared by writing '1') even if their corresponding interrupts are disabled. Figure 2-3 shows the EZ-USB registers that are associated with CONTROL transactions over EP0.

These registers augment those associated with normal bulk transfers, which are described in the Access to Endpoint Buffers chapter on page 87.

Two bits in the USBIE (USB Interrupt Enable) register enable the SETUP Token (SUTOK) and SETUP Data Available interrupts. The actual interrupt-request bits are in the USBIRQ (USB Interrupt Requests) register.

The EZ-USB transfers the eight SETUP bytes into eight bytes of RAM at SETUPDAT. A 16-bit pointer, SUDPTRH:L, provides hardware assistance for handling CONTROL IN transfers, in particular the 'Get Descriptor' requests described later in this chapter.

2.3 USB Requests

The Universal Serial Bus Specification Version 2.0, Chapter 9, USB Device Framework defines a set of Standard Device Requests. When the firmware is in control of endpoint zero (RENUM=1), the EZ-USB handles only one of these requests (Set Address) automatically; it relies on the firmware to support all of the others. The firmware acts on

device requests by decoding the eight bytes contained in the SETUP packet and available at SETUPDAT. Table 2-1 defines these eight bytes.

Table 2-1. The Eight Bytes in a USB SETUP Packet

Byte	Field	Meaning
0	bmRequestType	Request Type, Direction, and Recipient.
1	bRequest	The actual request (see Table 2-2).
2	wValueL	16-bit value, varies according to bRequest.
3	wValueH	
4	wIndexL	16-bit field, varies according to bRequest.
5	wIndexH	
6	wLengthL	Number of bytes to transfer if there is a data phase.
7	wLengthH	

The **Byte** column in Table 2-1 shows the byte offset from SETUPDAT. The **Field** column shows the different bytes in the request, where the 'bm' prefix means bitmap, 'b' means byte [8 bits, 0-255], and 'w' means word [16 bits, 0-65535].

Table 2-2 shows the different values defined for bRequest, and how the firmware should respond to each request. The remainder of this chapter describes each of the requests in Table 2-2 in detail.

Note Table 2-2 applies when RENUM = 1, signifying that the firmware, rather than the EZ-USB hardware, handles device requests.

Table 2-2. How the Firmware Handles USB Device Requests (RENUM =1)

bRequest	Name	EZ-USB Action	Firmware Response
0x00	Get Status	SUDAV Interrupt	Supply RemWU, SelfPwr or Stall Bits
0x01	Clear Feature	SUDAV Interrupt	Clear RemWU, SelfPwr or Stall Bits
0x02	(reserved)	none	Stall EP0
0x03	Set Feature	SUDAV Interrupt	Set RemWU, SelfPwr or Stall Bits
0x04	(reserved)	none	Stall EP0
0x05	Set Address	Update FNADDR Register	none
0x06	Get Descriptor	SUDAV Interrupt	Supply table data over EP0-IN
0x07	Set Descriptor	SUDAV Interrupt	Application dependent
0x08	Get Configuration	SUDAV Interrupt	Send current configuration number
0x09	Set Configuration	SUDAV Interrupt	Change current configuration
0x0A	Get Interface	SUDAV Interrupt	Supply alternate setting No. from RAM
0x0B	Set Interface	SUDAV Interrupt	Change alternate setting No.
0x0C	Sync Frame	SUDAV Interrupt	Supply a frame number over EP0-IN
Vendor Requests			
0xA0 (Firmware Load)		Upload / Download on-chip RAM	---
0xA1 to 0xAF		SUDAV Interrupt	Reserved by Cypress Semiconductor
All except 0xA0		SUDAV Interrupt	Application dependent

In the ReNumerated condition (RENUM = 1), the EZ-USB passes all USB requests except Set Address to the firmware via the SUDAV interrupt.

The EZ-USB implements one vendor-specific request: 'Firmware Load,' 0xA0 (the bRequest value of 0xA0 is valid only if byte 0 of the request, bmRequestType, is also 'x10xxxxx,' indicating a vendor-specific request.) The 0xA0 firmware load request may be used even after ReNumeration, but is only valid while the 8051 is held in reset. If your application implements vendor-specific USB requests, and you do not wish to use the Firmware Load feature, be sure to refrain from using the bRequest value 0xA0 for your custom requests. The Firmware Load feature is fully described in the [Enumeration and ReNumeration™ chapter on page 51](#).

To avoid future incompatibilities, vendor requests 0xA0-0xAF are reserved by Cypress Semiconductor.

2.3.1 Get Status

The USB Specification defines three USB status requests. A fourth request, to an interface, is declared in the specification as 'reserved'. The four status requests are:

- Remote Wakeup (Device request)
- Self-Powered (Device request)
- Stall (Endpoint request)
- Interface request (reserved)

The EZ-USB automatically asserts the SUDAV interrupt to tell the firmware to decode the SETUP packet and supply the appropriate status information.

As [Figure 2-4](#) illustrates, the firmware responds to the SUDAV interrupt by decoding the eight bytes the EZ-USB has copied into RAM at SETUPDAT. The firmware answers a Get Status request (bRequest = 0) by loading two bytes into the EP0BUF buffer and loading the byte count register EP0BCH:L with the value 0x0002. The EZ-USB then transmits these two bytes in response to an IN token. Finally, the firmware clears the HSNACK bit (by writing '1' to it), which instructs the EZ-USB to ACK the status stage of the transfer.

Figure 2-4. Data Flow for a Get_Status Request

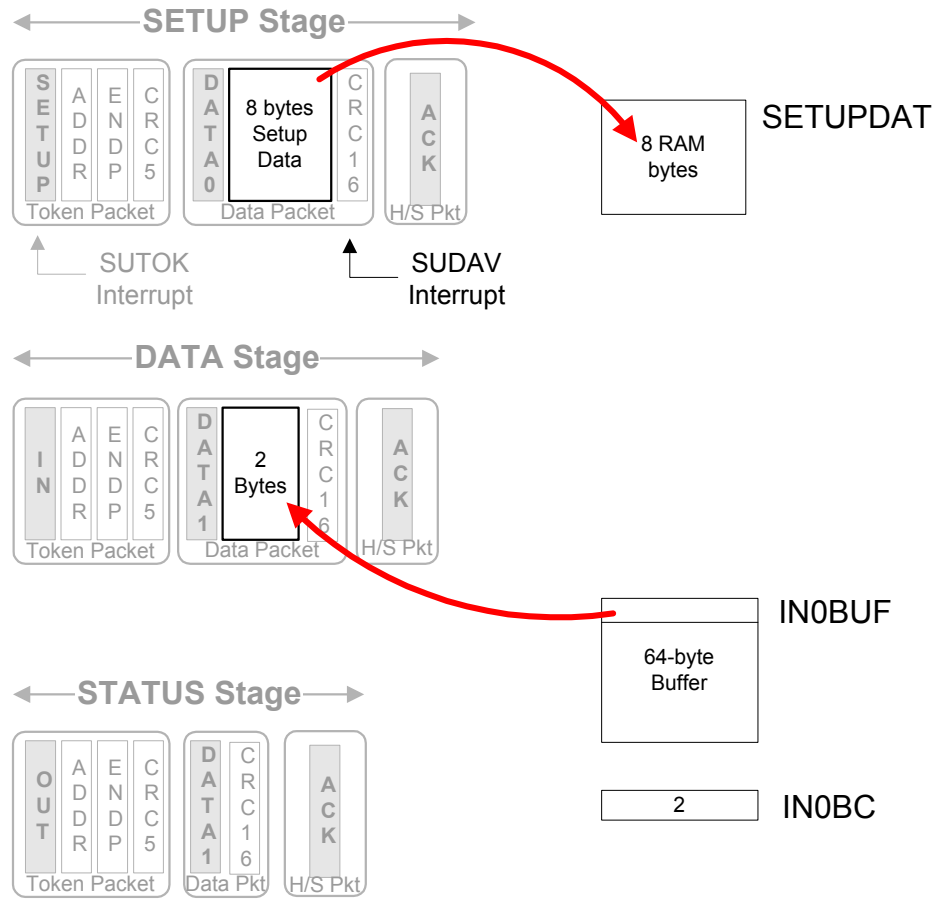

The following tables show the eight SETUP bytes for Get Status Requests.

Table 2-3. Get Status-Device (Remote Wakeup and Self-Powered Bits)

Byte	Field	Value	Meaning	Firmware Response
0	bmRequestType	0x80	IN, Device	Load two bytes into EP0BUF: Byte 0: bit 0 = Self-Powered Byte 0: bit 1 = Remote Wakeup Byte 1: zero
1	bRequest	0x00	'Get Status'	
2	wValueL	0x00		
3	wValueH	0x00		
4	wIndexL	0x00		
5	wIndexH	0x00		
6	wLengthL	0x02	Two bytes requested	
7	wLengthH	0x00		

Get Status-Device queries the state of two bits, 'Remote Wakeup' and 'Self-Powered'. The Remote Wakeup bit indicates whether or not the device is currently enabled to request remote wakeup (remote wakeup is explained in the [Power Management chapter on page 77](#)). The Self-Pow-

ered bit indicates whether or not the device is self-powered (as opposed to USB bus-powered).

The firmware returns these two bits by loading two bytes into EP0BUF, then loading a byte count of 0x0002 into EP0BCH:L.

Table 2-4. Get Status-Endpoint (Stall Bits)

Byte	Field	Value	Meaning	Firmware Response
0	bmRequestType	0x82	IN, Endpoint	Load two bytes into EP0BUF: Byte 0: bit 0 = Stall Bit for EP(n) Byte 1: zero
1	bRequest	0x00	'Get Status'	
2	wValueL	0x00		
3	wValueH	0x00		
4	wIndexL	EP	0x00-0x08: OUT0-OUT8	
5	wIndexH	0x00	0x80-0x88: IN0-IN8	
6	wLengthL	0x02	Two bytes requested	
7	wLengthH	0x00		

Each endpoint has a STALL bit in its EPxCS register. If this bit is set, any request to the endpoint returns a STALL hand-

Endpoint Zero

shake rather than ACK or NAK. The Get Status-Endpoint request returns the STALL state for the endpoint indicated in byte 4 of the request. Note that bit 7 of the endpoint number EP (byte 4) specifies direction (0 = OUT, 1 = IN).

Endpoint zero is a CONTROL endpoint, which by USB definition is bidirectional. Therefore, it has only one stall bit.

About STALL

The USB STALL handshake indicates that something unexpected has happened. For instance, if the host requests an invalid alternate setting or attempts to send data to a nonexistent endpoint, the device responds with a STALL handshake over endpoint zero instead of ACK or NAK.

Stalls are defined for all endpoint types except ISOCHRONOUS, which does not employ handshakes. Every EZ-USB bulk endpoint has its own stall bit. The firmware sets the stall condition for an endpoint by setting the STALL bit in the endpoint's EPxCS register. The host tells the firmware to set or clear the stall condition for an endpoint using the Set Feature/Stall and Clear Feature/Stall requests.

The device might also set the stall condition on its own. In a routine that handles endpoint zero device requests, for example, when a request that is not defined or not supported is decoded, the firmware should stall EPO.

Once the firmware stalls an endpoint, it should not remove the stall until the host issues a Clear Feature/Stall request. An exception to this rule is endpoint 0, which reports a stall condition only for the current transaction and then automatically clears the stall condition. This prevents endpoint 0, the default CONTROL endpoint, from locking out device requests.

Table 2-5. Get Status-Interface

Byte	Field	Value	Meaning	Firmware Response
0	bmRequestType	0x81	IN, Endpoint	Load two bytes into EPOBUF: Byte 0: zero Byte 1: zero
1	bRequest	0x00	'Get Status'	
2	wValueL	0x00		
3	wValueH	0x00		
4	wIndexL	0x00		
5	wIndexH	0x00		
6	wLengthL	0x02	Two bytes requested	
7	wLengthH	0x00		

Get Status/Interface is easy: the firmware returns two zero bytes through EPOBUF and clears the HSNACK bit (by writing '1' to it). The requested bytes are shown as 'Reserved (reset to zero)' in the USB Specification.

2.3.2 Set Feature

Set Feature is used to enable remote wakeup, stall an endpoint, or put the device into a specific test mode. No data stage is required.

Table 2-6. Set Feature-Device (Set Remote Wakeup Bit)

Byte	Field	Value	Meaning	Firmware Response
0	bmRequestType	0x00	OUT, Device	Set the Remote Wakeup Bit
1	bRequest	0x03	'Set Feature'	
2	wValueL	0x01	Feature Selector: Remote Wakeup	
3	wValueH	0x00		
4	wIndexL	0x00		
5	wIndexH	0x00		
6	wLengthL	0x00		
7	wLengthH	0x00		

This Set Feature/Device request sets the remote wakeup bit. This is the same bit reported back to the host as a result of a Get Status-Device request (Table 2-3 on page 41). The host uses this bit to enable or disable remote wakeup by the device.

Table 2-7. Set Feature-Device (Set TEST_MODE Feature)

Byte	Field	Value	Meaning	Firmware Response
0	bmRequestType	0x00	OUT, Device	ACK handshake phase
1	bRequest	0x03	'Set Feature'	
2	wValueL	0x02	Feature Selector: TEST_MODE	
3	wValueH	0x00		
4	wIndexL	0x00		
5	wIndexH	0xnn	nn = specific test mode	
6	wLengthL	0x00		
7	wLengthH	0x00		

This Set Feature/Device request sets the TEST_MODE feature. This request puts the device into a specific test mode, and power to the device must be cycled in order to exit test mode. The EZ-USB SIE handles this request automatically, but the firmware is responsible for acknowledging the handshake phase.

Table 2-8. Set Feature-Endpoint (Stall)

Byte	Field	Value	Meaning	Firmware Response
0	bmRequestType	0x02	OUT, Endpoint	Set the STALL bit for the indicated endpoint.
1	bRequest	0x03	'Set Feature'	
2	wValueL	0x00	Feature Selector: STALL	
3	wValueH	0x00		
4	wIndexL	EP	0x00-0x08: OUT0-OUT8	
5	wIndexH	0x00	0x80-0x88: IN0-IN8	
6	wLengthL	0x00		
7	wLengthH	0x00		

The only Set Feature/Endpoint request presently defined in the USB Specification is to stall an endpoint. The firmware should respond to this request by setting the STALL bit in the EPxCS register for the indicated endpoint EP (byte 4 of the request). The firmware can either stall an endpoint on its own or in response to the device request. Endpoint stalls are cleared by the host Clear Feature/Stall request.

The firmware should respond to the Set Feature/Stall request by performing the following tasks:

1. Set the STALL bit in the indicated endpoint's EPxCS register.
2. Reset the data toggle for the indicated endpoint.
3. Restore the stalled endpoint to its default condition, ready to send or accept data after the stall condition is removed by the host (via a Clear Feature/Stall request). For EP1 IN, for example, firmware should clear the BUSY bit in the EP1CS register; for EP1OUT, firmware should load any value into the EP1 byte-count register.
4. Clear the HSNACK bit in the EP0CS register (by writing 1 to it) to terminate the Set Feature/Stall CONTROL transfer.

Step 3 is also required whenever the host sends a 'Set Interface' request.

Data Toggles

The EZ-USB automatically maintains the endpoint toggle bits to ensure data integrity for USB transfers. Firmware should directly manipulate these bits only for a very limited set of circumstances:

- Set Feature/Stall
- Set Configuration
- Set Interface

2.3.3 Clear Feature

Clear Feature is used to disable remote wakeup or to clear a stalled endpoint.

Table 2-9. Clear Feature-Device (Clear Remote Wakeup Bit)

Byte	Field	Value	Meaning	Firmware Response
0	bmRequestType	0x00	OUT, Device	Clear the remote wakeup bit.
1	bRequest	0x01	'Clear Feature'	
2	wValueL	0x01	Feature Selector: Remote Wakeup	
3	wValueH	0x00		
4	wIndexL	0x00		
5	wIndexH	0x00		
6	wLengthL	0x00		
7	wLengthH	0x00		

Table 2-10. Clear Feature-Endpoint (Clear Stall)

Byte	Field	Value	Meaning	Firmware Response
0	bmRequestType	0x02	OUT, Endpoint	Clear the STALL bit for the indicated endpoint.
1	bRequest	0x01	'Clear Feature'	
2	wValueL	0x00	Feature Selector: STALL	
3	wValueH	0x00		
4	wIndexL	EP	0x00-0x08: OUT0-OUT8	
5	wIndexH	0x00	0x80-0x88: IN0-IN8	
6	wLengthL	0x00		
7	wLengthH	0x00		

If the USB device supports remote wakeup (reported in its descriptor table when the device enumerates), the *Clear Feature/Remote Wakeup* request disables the wakeup capability.

The *Clear Feature/Stall* removes the stall condition from an endpoint. The firmware should respond by clearing the STALL bit in the indicated endpoint's EPxCS register.

2.3.4 Get Descriptor

During enumeration, the host queries a USB device to learn its capabilities and requirements using Get Descriptor requests. Using tables of descriptors, the device sends back (over EP0-IN) such information as what device driver to load, how many endpoints it has, its different configurations, alternate settings it may use, and informative text strings about the device.

The EZ-USB provides a special Setup Data Pointer to simplify firmware service for Get_Descriptor requests. The firmware loads this 16-bit pointer with the starting address of the requested descriptor, clears the HSNACK bit (by writing '1' to it), and the EZ-USB transfers the entire descriptor.

Figure 2-5. Using Setup Data Pointer (SUDPTR) for Get_Descriptor Requests

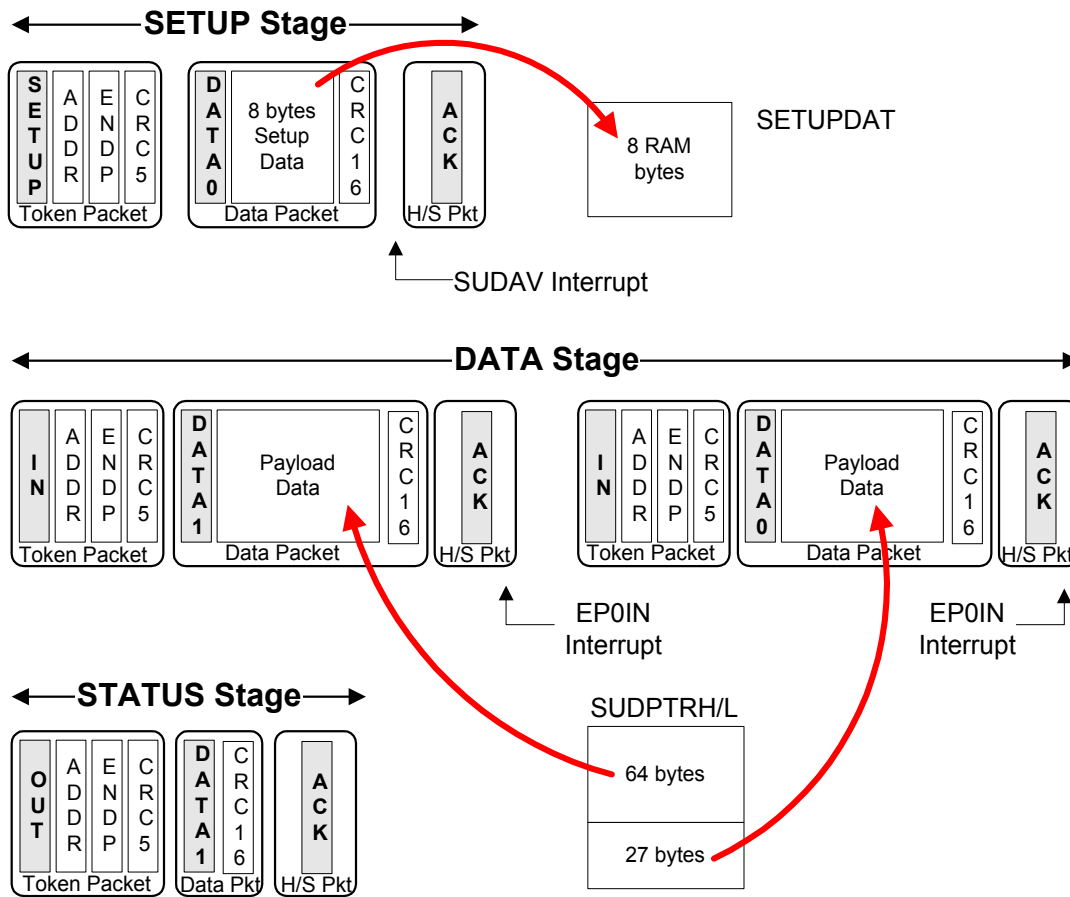

Figure 2-5 illustrates use of the Setup Data Pointer. This pointer is implemented as two registers, SUDPTRH and SUDPTRL. The base address of SUDPTRH:L must be word-aligned. Most Get Descriptor requests involve transferring more data than fits into one packet. In the Figure 2-5 example, the descriptor data consists of 91 bytes.

The CONTROL transaction starts in the usual way, with the EZ-USB automatically transferring the eight bytes from the SETUP packet into RAM at SETUPDAT, then asserting the SUDAV interrupt request. The firmware decodes the Get Descriptor request, and responds by clearing the HSNACK bit (by writing '1' to it), and then loading the SUDPTRH:L registers with the address of the requested descriptor. Loading the SUDPTRL register causes the EZ-USB to automatically respond to two IN transfers with 64 bytes and 27 bytes of data using SUDPTRH:L as a base address, and then to respond to the STATUS stage with an ACK.

The usual endpoint-zero interrupts SUDAV and EP0IN remain active during this automated transfer, so firmware normally disables these interrupts because the transfer requires no firmware intervention.

Three types of descriptors are defined: Device, Configuration, and String.

2.3.4.1 Get Descriptor-Device

Table 2-11. Get Descriptor-Device

Byte	Field	Value	Meaning	Firmware Response
0	bmRequestType	0x80	IN, Device	Set SUDPTRH:L to start of Device Descriptor table in RAM.
1	bRequest	0x06	'Get Descriptor'	
2	wValueL	0x00		
3	wValueH	0x01	Descriptor Type: Device	
4	wIndexL	0x00		
5	wIndexH	0x00		
6	wLengthL	LenL		
7	wLengthH	LenH		

As illustrated in Figure 2-5 on page 44, the firmware loads the two-byte SUDPTRH:L with the starting address of the Device Descriptor table. The start address needs to be

word-aligned. When SUDPTRL is loaded, the EZ-USB automatically performs the following operations:

1. Reads the requested number of bytes for the transfer from bytes 6 and 7 of the SETUP packet (LenL and LenH in [Table 2-11](#)).
2. Reads the requested descriptor's length field to determine the actual descriptor length.
3. Sends the smaller of (a) the requested number of bytes or (b) the actual number of bytes in the descriptor, over EP0BUF using the Setup Data Pointer as a data table index. This constitutes the second phase of the three-phase CONTROL transfer. The EZ-USB packetizes the data into multiple data transfers as necessary.
4. Automatically checks for errors and re-transmits data packets if necessary.
5. Responds to the third (handshake) phase of the CONTROL transfer to terminate the operation.

The Setup Data Pointer can be used for any Get Descriptor request (for example, Get Descriptor-String).

It can also be used for vendor-specific requests. If bytes six and seven of those requests contain the number of bytes in the transfer (see Step 1, above), the Setup Data Pointer works automatically, as it does for Get Descriptor requests; if bytes six and seven do not contain the length of the transfer, the length can be loaded explicitly (see the SDPAUTO paragraphs of section [8.7 The Setup Data Pointer on page 95](#)).

It is possible for the firmware to do manual CONTROL transfers by directly loading the EP0BUF buffer with the various packets and keeping track of which SETUP phase is in effect. This is a good USB training exercise, but not necessary due to the hardware support built into the EZ-USB for CONTROL transfers.

For DATA stage transfers of fewer than 64 bytes, moving the data into the EP0BUF buffer and then loading the EP0BCH:L registers with the byte count would be equivalent to loading the Setup Data Pointer. However, this would waste bandwidth because it requires byte transfers into the EP0BUF Buffer; using the Setup Data Pointer does not.

2.3.4.2 Get Descriptor-Device Qualifier

Table 2-12. Get Descriptor-Device Qualifier

Byte	Field	Value	Meaning	Firmware Response
0	bmRequestType	0x80	IN, Device	Set SUDPTR H:L to start of the appropriate Device Qualifier Descriptor table in RAM.
1	bRequest	0x06	'Get Descriptor'	
2	wValueL	0x00		
3	wValueH	0x06	Descriptor Type: Device Qualifier	
4	wIndexL	0x00		
5	wIndexH	0x00		
6	wLengthL	LenL		
7	wLengthH	LenH		

The Device Qualifier descriptor is used only by devices capable of high-speed (480 Mbps) operation; it describes information about the device that would change if the device were operating at the other speed (for example, if the device is currently operating at high speed, the device qualifier returns information about how it would operate at full speed and vice-versa).

Device Qualifier descriptors are handled just like Device descriptors; the firmware loads the appropriate descriptor address (must be word-aligned) into SUDPTRH:L, then the EZ-USB does the rest.

2.3.4.3 Get Descriptor-Configuration

Table 2-13. Get Descriptor-Configuration

Byte	Field	Value	Meaning	Firmware Response
0	bmRequestType	0x80	IN, Device	Set SUDPTR H:L to start of Configuration Descriptor table in RAM
1	bRequest	0x06	'Get Descriptor'	
2	wValueL	CFG	Configuration Number	
3	wValueH	0x02	Descriptor Type: Configuration	
4	wIndexL	0x00		
5	wIndexH	0x00		
6	wLengthL	LenL		
7	wLengthH	LenH		

2.3.4.4 Get Descriptor-String

Table 2-14. Get Descriptor-String

Byte	Field	Value	Meaning	Firmware Response
0	bmRequestType	0x80	IN, Device	Set SUDPTR H:L to start of String Descriptor table in RAM.
1	bRequest	0x06	'Get Descriptor'	
2	wValueL	STR	String Number	
3	wValueH	0x03	Descriptor Type: String	
4	wIndexL	0x00	(Language ID L)	
5	wIndexH	0x00	(Language ID H)	
6	wLengthL	LenL		
7	wLengthH	LenH		

Configuration and String descriptors are handled similarly to Device descriptors. The firmware reads byte 2 of the SETUP data to determine which configuration or string is being requested, then loads the corresponding descriptor address (must be word-aligned) into SUDPTRH:L. The EZ-USB does the rest.

2.3.4.5 Get Descriptor-Other Speed Configuration

Table 2-15. Get Descriptor-Other Speed Configuration

Byte	Field	Value	Meaning	Firmware Response
0	bmRequestType	0x80	IN, Device	Set SUDPTR H:L to start of Other Speed Configuration Descriptor table in RAM.
1	bRequest	0x06	'Get Descriptor'	
2	wValueL	CFG	Other Speed Configuration Number	
3	wValueH	0x07	Descriptor Type: Other Speed Configuration	
4	wIndexL	0x00	(Language ID L)	
5	wIndexH	0x00	(Language ID H)	
6	wLengthL	LenL		
7	wLengthH	LenH		

The Other Speed Configuration descriptor is used only by devices capable of high-speed (480 Mbps) operation; it describes the configurations of the device if it were operating at the other speed (that is, if the device is currently operating at high speed, the Other Speed Configuration returns information about full-speed configuration and vice-versa).

Other Speed Configuration descriptors are handled just like Configuration descriptors; the firmware loads the appropriate descriptor address (must be word-aligned) into SUDPTRH:L, then the EZ-USB does the rest.

2.3.5 Set Descriptor

Table 2-16. Set Descriptor-Device

Byte	Field	Value	Meaning	Firmware Response
0	bmRequestType	0x00	OUT, Device	Read device descriptor data over EPOBUF.
1	bRequest	0x07	'Set Descriptor'	
2	wValueL	0x00		
3	wValueH	0x01	Descriptor Type: Device	
4	wIndexL	0x00		
5	wIndexH	0x00		
6	wLengthL	LenL		
7	wLengthH	LenH		

Table 2-17. Set Descriptor-Configuration

Byte	Field	Value	Meaning	Firmware Response
0	bmRequestType	0x00	OUT, Device	Read configuration descriptor data over EPOBUF.
1	bRequest	0x07	'Set Descriptor'	
2	wValueL	0x00		
3	wValueH	0x02	Descriptor Type: Configuration	
4	wIndexL	0x00		
5	wIndexH	0x00		
6	wLengthL	LenL		
7	wLengthH	LenH		

Table 2-18. Set Descriptor-String

Byte	Field	Value	Meaning	Firmware Response
0	bmRequestType	0x00	IN, Device	Read string descriptor data over EPOBUF.
1	bRequest	0x07	'Set Descriptor'	
2	wValueL	0x00	String Number	
3	wValueH	0x03	Descriptor Type: String	
4	wIndexL	0x00	(Language ID L)	
5	wIndexH	0x00	(Language ID H)	
6	wLengthL	LenL		
7	wLengthH	LenH		

The firmware handles Set Descriptor requests by clearing the HSNACK bit (by writing '1' to it), then reading descriptor data directly from the EPOBUF buffer. The EZ-USB keeps track of the number of bytes transferred from the host into EPOBUF, and compares this number with the length field in bytes six and seven. When the proper number of bytes has been transferred, the EZ-USB automatically responds to the STATUS phase, which is the third and final stage of the CONTROL transfer.

Note The firmware controls the flow of data in the Data Stage of a Control Transfer. After the firmware processes each OUT packet, it writes any value into the endpoint's byte count register to re-arm the endpoint.

Configurations, Interfaces, and Alternate Settings

A USB device has one or more **configurations**. Only one configuration is active at any time.

A configuration has one or more **interfaces**, all of which are concurrently active. Multiple interfaces allow different host-side device drivers to be associated with different portions of a USB device.

Each interface has one or more **alternate settings**. Each alternate setting has a collection of one or more endpoints.

This structure is a software model; the EZ-USB takes no action when these settings change. However, the firmware **must re-initialize endpoints and reset the dat toggle** when the host changes configurations or interfaces alternate settings.

As far as the firmware is concerned, a 'configuration' is simply a byte variable that indicates the current setting.

The host issues a 'Set Configuration' request to select a configuration, and a 'Get Configuration' request to determine the current configuration.

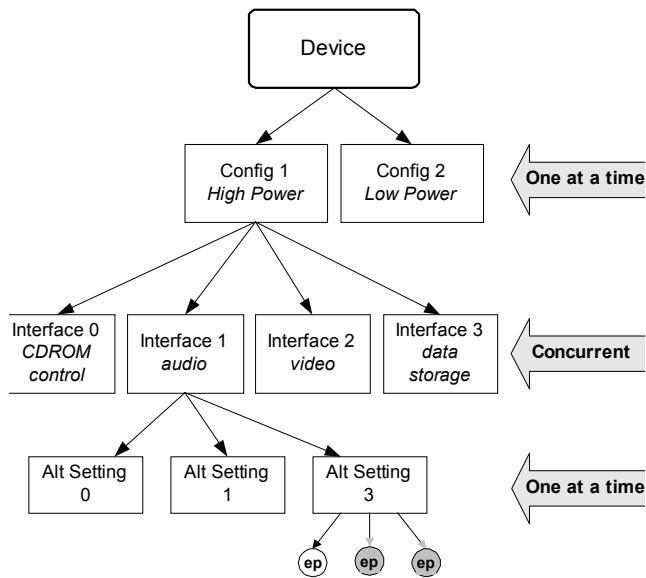

2.3.5.1 Set Configuration

Table 2-19. Set Configuration

Byte	Field	Value	Meaning	Firmware Response
0	bmRequestType	0x00	OUT, Device	Read and store CFG, change configurations in firmware.
1	bRequest	0x09	'Set Configuration'	
2	wValueL	CFG	Configuration Number	
3	wValueH	0x00		
4	wIndexL	0x00		
5	wIndexH	0x00		
6	wLengthL	0x00		
7	wLengthH	0x00		

When the host issues the 'Set Configuration' request, the firmware saves the configuration number (byte 2, CFG, in Table 2-19), performs any internal operations necessary to support the configuration, and finally clears the HSNACK bit (by writing '1' to it) to terminate the 'Set Configuration' CONTROL transfer.

Note After setting a configuration, the host issues Set Interface commands to set up the various interfaces contained in the configuration.

2.3.6 Get Configuration

Table 2-20. Get Configuration

Byte	Field	Value	Meaning	Firmware Response
0	bmRequestType	0x80	IN, Device	Send CFG over EP0 after reconfiguring.
1	bRequest	0x08	'Get Configuration'	
2	wValueL	0x00		
3	wValueH	0x00		
4	wIndexL	0x00		
5	wIndexH	0x00		
6	wLengthL	1	LenL	
7	wLengthH	0	LenH	

When the host issues the 'Get Configuration' request, the firmware returns the current configuration number. It loads the configuration number into EP0BUF, loads a byte count of one into EP0BCH:L, and finally clears the HSHAK bit (by writing '1' to it) to terminate the 'Set Configuration' CONTROL transfer.

2.3.7 Set Interface

This confusingly-named USB command actually sets 'alternate settings' for a specified interface.

USB devices can have multiple concurrent interfaces. For example, a device may have an audio system that supports

different sample rates, and a graphic control panel that supports different languages. Each interface has a collection of endpoints. Except for endpoint 0, which each interface uses for device control, endpoints may not be shared between interfaces.

Interfaces may report alternate settings in their descriptors. For example, the audio interface may have settings '0', '1', and '2' for 8-kHz, 22-kHz, and 44-kHz sample rates, respectively. The panel interface may have settings '0' and '1' for English and Spanish, respectively. The *Set/Get Interface* requests select among the various alternate settings in an interface.

Table 2-21. Set Interface (Actually, Set Alternate Setting #AS for Interface #IF)

Byte	Field	Value	Meaning	Firmware Response
0	bmRequestType	0x00	OUT, Device	Read and store byte 2 (AS) for Interface #IF, change setting for Interface #IF in firmware.
1	bRequest	0x0B	'Set Interface'	
2	wValueL	AS	Alternate Setting Number	
3	wValueH	0x00		
4	wIndexL	IF	Interface Number	
5	wIndexH	0x00		
6	wLengthL	0x00		
7	wLengthH	0x00		

The firmware should respond to a Set Interface request by performing the following steps:

1. Perform the internal operation requested (such as adjusting a sampling rate).
2. Reset the data toggles for every endpoint in the interface.
3. Restore the endpoints to their default conditions, ready to send or accept data. For EP1 IN, for example, firmware should clear the BUSY bit in the EP1CS register; for EP1OUT, firmware should load any value into the EP1 byte-count register.
4. Clear the HSNACK bit (by writing '1' to it) to terminate the Set Interface CONTROL transfer.

2.3.8 Get Interface

Table 2-22. Get Interface (Actually, Get Alternate Setting #AS for interface #IF)

Byte	Field	Value	Meaning	Firmware Response
0	bmRequestType	0x81	IN, Device	Send AS for Interface #IF over EP0.
1	bRequest	0x0A	'Get Interface'	
2	wValueL	0x00		
3	wValueH	0x00		
4	wIndexL	IF	Interface Number	
5	wIndexH	0x00		
6	wLengthL	1	LenL	
7	wLengthH	0	LenH	

When the host issues the Get Interface request, the firmware simply returns the alternate setting for the requested interface IF and clears the HSNACK bit (by writing '1' to it).

2.3.9 Set Address

When a USB device is first plugged in, it responds to device address 0 until the host assigns it a unique address using the Set Address request. The EZ-USB copies this device address into the FNADDR (Function Address) register, then subsequently responds only to requests to this address. This address is in effect until the USB device is unplugged, the host issues a USB Reset, or the host powers down.

The FNADDR register is read-only. Whenever the EZ-USB ReNumerates™ (see [Enumeration and ReNumeration™, on page 51](#)), it automatically resets FNADDR to zero, allowing the device to come back as new.

An EZ-USB program does not need to know the device address, because the EZ-USB automatically responds only to the host-assigned FNADDR value. The device address is readable only for debug/diagnostic purposes.

2.3.10 Sync Frame

Table 2-23. Sync Frame

Byte	Field	Value	Meaning	Firmware Response
0	bmRequestType	0x82	IN, Endpoint	Send a frame number over EP0 to synchronize endpoint #EP
1	bRequest	0x0C	'Sync Frame'	
2	wValueL	0x00		
3	wValueH	0x00		
4	wIndexL	EP	Endpoint number	
5	wIndexH	0x00		
6	wLengthL	2	LenL	
7	wLengthH	0	LenH	

The 'Sync Frame' request is used to establish a marker in time so the host and USB device can synchronize multi-frame transfers over isochronous endpoints.

Suppose an isochronous transmission consists of a repeating sequence of five 300-byte packets transmitted from host to device over EP8-OUT. Both host and device maintain sequence counters that count repeatedly from 1 to 5 to keep track of the packets inside a transmission. To start up in sync, both host and device need to reset their counts to '0' at the same time (in the same frame).

To get in sync, the host issues the Sync Frame request with EP=EP8OUT (0x08). The firmware responds by loading EP0BUF with a two-byte frame count for some future time; for example, the current frame plus 20. This marks frame 'current+20' as the sync frame, during which both sides initialize their sequence counters to '0.' The current frame count is always available in the USBFRAMEL and USBFRAMEH registers.

Multiple isochronous endpoints can be synchronized in this manner; the firmware can keep a separate internal sequence count for each endpoint.

About USB Frames

In full-speed mode (12 Mbps), the USB host issues an SOF (Start Of Frame) packet once every millisecond. Every SOF packet contains an 11-bit (mod-2048) frame number. The firmware services all isochronous transfers at SOF time, using a single SOF interrupt request and vector. If the EZ-USB detects a missing or garbled SOF packet, it can use an internal counter to generate the SOF interrupt automatically.

In high-speed mode (480 Mbps), each frame is divided into eight 125-microsecond microframes. Although the frame counter still increments only once per frame, the host issues an SOF every microframe. The host and device always synchronize on the zero-th microframe of the frame specified in the device's response to the Sync Frame request; there is no mechanism for synchronizing on any other microframe.

2.3.11 Firmware Load

The USB endpoint-zero protocol provides a mechanism for mixing vendor-specific requests with standard device requests. Bits 6:5 of the bmRequestType field are set to 00 for a standard device request and to 10 for a vendor request.

Table 2-24. Firmware Download

Byte	Field	Value	Meaning	Firmware Response
0	bmRequestType	0x40	Vendor Request, OUT	None required.
1	bRequest	0xA0	'Firmware Load'	
2	wValueL	Addr L	Starting address	
3	wValueH	Addr H		
4	wIndexL	0x00		
5	wIndexH	0x00		
6	wLengthL	LenL	Number of bytes	
7	wLengthH	LenH		

Table 2-25. Firmware Upload

Byte	Field	Value	Meaning	Firmware Response
0	bmRequestType	0xC0	Vendor Request, IN	None Required.
1	bRequest	0xA0	'Firmware Load'	
2	wValueL	Addr L	Starting address	
3	wValueH	Addr H		
4	wIndexL	0x00		
5	wIndexH	0x00		
6	wLengthL	LenL	Number of Bytes	
7	wLengthH	LenH		

The EZ-USB responds to two endpoint-zero vendor requests, RAM Download and RAM Upload. These requests are active whether RENUM=0 or RENUM=1, but can only occur while the 8051 is held in reset. RAM Uploads can only occur on word boundaries (i.e. the start address must be evenly divisible by two). The same restriction does not apply to RAM Downloads.

Because bit 7 of the first byte of the SETUP packet specifies direction, only one bRequest value (0xA0) is required for the upload and download requests. These RAM load commands are available to any USB device that uses the EZ-USB chip.

A host loader program must write 0x01 to the CPUCS register to put the EZ-USB's CPU into RESET, load all or part of the EZ-USB's internal RAM with code, then reload the CPUCS register with zero to take the CPU out of RESET.

3. Enumeration and ReNumeration™



3.1 Introduction

The EZ-USB's configuration is 'soft': Code and data are stored in internal RAM, which can be loaded from the host over the USB interface. EZ-USB-based USB peripherals can operate without ROM, EPROM, or FLASH memory, shortening production lead times and making firmware updates extremely simple.

To support this soft configuration, the EZ-USB is capable of enumerating as a USB device without firmware. This automatically-enumerated USB device (the Default USB Device) contains a set of interfaces and endpoints and can accept firmware downloaded from the host. However, at a minimum, an I²C™ boot EEPROM is required for production (see [3.2 EZ-USB Startup Modes](#) for more details).

Note For the FX2LP, two separate Default USB Devices actually exist, one for enumeration as a full-speed (12 Mbps) device, and the other for enumeration as a high-speed (480 Mbps) device. The FX2LP automatically performs the speed-detect protocol and chooses the proper Default USB Device. The two sets of Default USB Device descriptors are shown in Appendices A and B.

Once the Default USB Device enumerates and the host downloads firmware and descriptor tables to the EZ-USB, it then begins executing the downloaded code, which electrically simulates a physical disconnect/connect from the USB and causes the EZ-USB to enumerate again as a second device, this time taking on the USB personality defined by the downloaded code and descriptors. This patented secondary enumeration process is called 'ReNumeration™'.

An EZ-USB register bit called RENUM controls whether device requests over endpoint zero are handled by firmware or automatically by the Default USB Device. When RENUM = 0, the Default USB Device handles the requests automatically; when RENUM = 1, they must be handled by firmware.

3.2 EZ-USB Startup Modes

When the EZ-USB comes out of reset, it can act in various ways to establish itself as a USB device. EZ-USB power-on behavior depends on several factors:

1. If no off chip memory (either on the I2C bus or on the address/data bus) is connected to the EZ-USB, it enumerates as the Default USB Device, with descriptors and VID/PID/DID supplied by hardwired internal logic ([Table 3-3 on page 52](#)). RENUM is set to '0', indicating that the Default USB Device automatically handles device requests. This startup mode is not allowed for production devices, since it uses the Cypress VID, and is detailed here for completeness only.
2. If an EEPROM containing custom VID/PID/DID values is attached to the EZ-USB's I2C bus, EZ-USB also enumerates as the Default USB Device as above, but it substitutes the VID/PID/DID values from the EEPROM for its internal values. The EEPROM must contain the value 0xC0 in its first byte to indicate this mode to EZ-USB, so this mode is called a 'C0 Load'. As above, RENUM is automatically set to '0', indicating that the Default USB Device automatically handles device requests. A 16 byte EEPROM is sufficiently large for a C0 Load. A C0 Load is often used to automate downloading firmware via USB.
3. If an EEPROM containing EZ-USB firmware is attached to the I2C bus, the firmware is automatically loaded from the EEPROM into the EZ-USB's on chip RAM, and then the CPU is taken out of reset to execute this boot-loaded code. In this case, the VID/PID/DID values are encapsulated in the firmware; the RENUM bit is automatically set to '1' to indicate that the firmware, not the Default USB Device, handles device requests. The EEPROM must contain the value 0xC2 in its first byte to indicate this mode to EZ-USB, so this mode is called a 'C2 Load'. **Note** Although the EZ-USB can perform C2 Loads from EEPROMs as large as 64 KB, code can only be downloaded to the 16K of on chip RAM. Using bootloader firmware allows download to external RAM.

4. If a Flash, EPROM, or other memory is attached to the EZ-USB's address/data bus (128-pin package only) and a properly formatted EEPROM meeting the requirements above is **not** present, and the EA pin is tied high (indicating that the EZ-USB starts code execution at 0x0000 from off-chip memory), the EZ-USB begins executing firmware from the off chip memory. In this case, the VID/PID/DID values are encapsulated in the firmware; the RENUM bit is automatically set to '1' to indicate that the firmware, not internal EZ-USB logic, handles device requests.

Case (2) is the most frequently used mode when soft operation is desired, since the VID/PID values from EEPROM always bind the device to the appropriate host driver while allowing EZ-USB firmware to be easily updated. In this case, the host first holds the CPU in reset, uses the EZ-USB Default USB Device to download firmware, then the host takes the CPU out of reset so that it can execute the downloaded code. Section 3.8 EZ-USB Vendor Request for Firmware Load on page 56 describes the USB 'Vendor Request' that the EZ-USB supports for code download and upload.

Note The Default USB Device is fully characterized in Appendices A and B, which list the built-in EZ-USB descriptor tables for full-speed and high-speed enumeration, respectively. Studying these Appendices in conjunction with Table 3-1 and Table 3-2 is an excellent way to learn the structure of USB descriptors.

3.3 The Default USB Device

The Default USB Device consists of a single USB configuration containing one interface (interface 0) and alternate settings 0, 1, 2 and 3. The endpoints and MaxPacketSizes reported for this device are shown in Table 3-1 (full speed) and Table 3-2 (high speed). Note that alternate setting zero consumes no interrupt or isochronous bandwidth, as recommended by the USB Specification.

Table 3-1. Default Full Speed Alternate Settings

Alternate Setting	0	1	2	3
ep0	64	64	64	64
ep1out	0	64 bulk	64 int	64 int
ep1in	0	64 bulk	64 int	64 int
ep2	0	64 bulk out (2x)	64 int out (2x)	64 iso out (2x)
ep4	0	64 bulk out (2x)	64 bulk out (2x)	64 bulk out (2x)
ep6	0	64 bulk in (2x)	64 int in (2x)	64 iso in (2x)
ep8	0	64 bulk in (2x)	64 bulk in (2x)	64 bulk in (2x)

Note: '0' means 'not implemented', '2x' means double buffered.

Table 3-2. Default High Speed Alternate Settings

Alternate Setting	0	1	2	3
ep0	64	64	64	64
ep1out	0	512 bulk	64 int	64 int
ep1in	0	512 bulk	64 int	64 int
ep2	0	512 bulk out (2x)	512 int out (2x)	512 iso out (2x)
ep4	0	512 bulk out (2x)	512 bulk out (2x)	512 bulk out (2x)
ep6	0	512 bulk in (2x)	512 int in (2x)	512 iso in (2x)
ep8	0	512 bulk in (2x)	512 bulk in (2x)	512 bulk in (2x)

Note: '0' means 'not implemented', '2x' means double buffered.

Note Although the physical size of the EP1 endpoint buffer is 64 bytes, it is reported as a 512 byte buffer for high speed alternate setting 1. This maintains compatibility with the USB specification, which allows only 512 byte bulk endpoints. If you use this default alternate setting, do not send/receive EP1 packets larger than 64 bytes.

3.4 EEPROM Boot-load Data Formats

This section describes three EEPROM boot-load scenarios and the EEPROM data formats that support them. The three scenarios are:

- No EEPROM, or EEPROM with invalid boot data
- 'C0' EEPROM (load custom VID / PID / DID only)
- 'C2' EEPROM (load firmware to on-chip RAM)

3.4.1 No EEPROM or Invalid EEPROM

In the simplest scenario, either no serial EEPROM is present on the ICbus or an EEPROM is present, but its first byte is neither 0xC0 nor 0xC2. In this case, descriptor data is supplied by hardwired internal EZ-USB tables. The EZ-USB enumerates as the Default USB Device, with the ID bytes shown in Table 3-3 or Table 3-4.

Note Pull up resistors are required on the SCL/SDA pins even if no device is connected. The resistors are required to allow EZ-USB logic to detect the 'No EEPROM / Invalid EEPROM' condition.

Table 3-3. Default ID Values for EZ-USB FX2LP, No EEPROM / Invalid EEPROM

Vendor ID	0x04B4 (Cypress Semiconductor)
Product ID	0x8613 (EZ-USB FX2LP)
Device Release	0xA _{nnn} (depends on chip revision, nnn = chip revision, where first silicon = 001)

Table 3-4. Default ID Values for EZ-USB FX1, No EEPROM / Invalid EEPROM

Vendor ID	0x04B4 (Cypress Semiconductor)
Product ID	0x6473 (EZ-USB FX1)
Device Release	0xAnnn (depends on chip revision, nnn = chip revision, where first silicon = 001)

The USB host queries the EZ-USB Default USB Device during enumeration, reads its device descriptor, and uses the IDs in Table 3-3 or Table 3-4 to determine which software driver to load into the operating system. This is a major USB feature — drivers are dynamically matched with devices and automatically loaded when a device is plugged in.

The ‘No EEPROM / Invalid EEPROM’ scenario is the simplest configuration, and also the most limiting. This configuration must only be used for code development, using Cypress software tools matched to the ID values in Table 3-3 or Table 3-4.

Note No USB peripheral based on the EZ-USB FX2LP or EZ-USB FX1 may use this configuration.

3.4.2 Serial EEPROM Present, First Byte is 0xC0

Table 3-5. ‘C0 Load’ Format

EEPROM Address	Contents
0	0xC0
1	Vendor ID (VID) L
2	Vendor ID (VID) H
3	Product ID (PID) L
4	Product ID (PID) H
5	Device ID (DID) L
6	Device ID (DID) H
7	Configuration byte

If, at power-on reset, the EZ-USB detects an EEPROM connected to its I2C bus with the value **0xC0** at address 0, the EZ-USB automatically copies the Vendor ID (VID), Product ID (PID), and Device ID (DID) from the EEPROM (Table 3-5) into internal storage. The EZ-USB then supplies these EEPROM bytes to the host as part of its response to the host’s Get Descriptor-Device request (these six bytes replace only the VID / PID / DID bytes in the Default USB Device descriptor). This causes a host driver matched to the VID / PID / DID values in the EEPROM to be loaded by the host OS.

After initial enumeration, that host driver holds the CPU in reset, downloads the firmware and USB descriptor data into the EZ-USB’s RAM, then releases the CPU reset. The EZ-USB then ReNumerates™ as a custom device. At that point, the host may load a new driver, bound to the VID / PID / DID contained in the firmware.

The eighth EEPROM byte contains configuration bits that control the following:

- I2C bus speed. **Note** Default is 100 kHz.
- Disconnect state. **Note** Default is for EZ-USB to come out of reset connected to USB.

Note Section [EEPROM Configuration Byte, on page 55](#) contains a full description of the configuration bits.

3.4.3 Serial EEPROM Present, First Byte is 0xC2

If, at power-on reset, the EZ-USB detects an EEPROM connected to its I2C with the value **0xC2** at address zero, the EZ-USB loads the EEPROM data into on-chip RAM. It also sets the RENUM bit to ‘1’, causing device requests to be handled by the firmware instead of the Default USB Device. The ‘C2 Load’ EEPROM data format is shown in Table 3-6.

Table 3-6. ‘C2 Load’ Format

EEPROM Address	Contents
0	0xC2
1	Vendor ID (VID) L
2	Vendor ID (VID) H
3	Product ID (PID) L
4	Product ID (PID) H
5	Device ID (DID) L
6	Device ID (DID) H
7	Configuration byte
8	Length H
9	Length L
10	Start Address H
11	Start Address L
---	Data Block

---	Length H
---	Length L
---	Start Address H
---	Start Address L
---	Data Block

---	0x80
---	0x01
---	0xE6
---	0x00
last	00000000

The first byte indicates a ‘C2 Load’, which instructs the EZ-USB to copy the EEPROM data into on-chip RAM. The EZ-USB reads the next six bytes (VID / PID / DID) even though they are not used by most C2 Load applications. The eighth byte (byte 7) is the configuration byte described in the previous section.

Note Bytes 1-6 of a C2 EEPROM can be loaded with VID / PID / DID bytes if it is desired at some point to run the firmware with RENUM = 0 (i.e., EZ-USB logic handles device requests), using the EEPROM VID / PID / DID rather than the development-only VID / PID / DID values shown in [Table 3-3 on page 52](#) or [Table 3-4 on page 53](#).

One or more data records follow, starting at EEPROM address 8. Each data record consists of a 10-bit Length field (0-1023) which indicates the number of bytes in the following data block, a 14-bit Start Address (0-0x3FFF) for the data block, and the data block itself.

The last data record, which must always consist of a single-byte load of 0x00 to the CPUCS register at 0xE600, is marked with a '1' in the most-significant bit of the Length field. Only the least-significant bit (8051RES) of this byte is writable by the download; that bit is set to zero to bring the CPU out of reset.

Note Serial EEPROM data can be loaded only into these three **on-chip** RAM spaces:

- Program/Data RAM at 0x0000-0x3FFF
- Data RAM at 0xE000-0xE1FF
- The CPUCS register at 0xE600 (only bit 0, 8051RES, is EEPROM loadable)

3.4.3.1 *General Purpose Use of the I2C Bus*

The EZ-USB's I2C controller serves two purposes. First, as described in this chapter, it manages the serial EEPROM interface that operates automatically at power-on to determine the enumeration method. Second, once the CPU is up and running, firmware can access the I2C controller for general-purpose use. This makes a wide range of standard I2C peripherals available to an EZ-USB-based system.

Other I2C devices can be attached to the SCL and SDA lines as long as there is no address conflict with the serial EEPROM described in this chapter. The [Input/Output chapter on page 181](#) describes the general-purpose nature of the I2C interface.

3.5 EEPROM Configuration Byte

The configuration byte is valid for both EEPROM load formats (C0 and C2) and has the following format:

Figure 3-1. EEPROM Configuration Byte

Configuration							
b7	b6	b5	b4	b3	b2	b1	b0
0	DISCON	0	0	0	0	0	400KHZ

Bit	Name	Description				
7		<p>The config byte of the .iic file must be changed so that the FX2 will start at full speed. The uVision project file contains the following iic generation line:</p> <pre>c:\cypress\usb\bin\hex2bix -c 0x80 -i -f 0xC2 -o bulkloop.iic bulkloop.hex</pre> <p>This line sets bit 7 of the config byte with the “-c 0x80”. Setting bit 7 prevents the FX2 from entering high-speed mode on startup.</p>				
6	DISCON (USB Disconnect)	<p>A USB hub or host detects attachment of a full speed device by sensing a high level on the D+ wire. A USB device provides this high level using a 1500-ohm resistor between D+ and 3.3V (the D+ line is normally low, pulled down by a 15 KΩ resistor in the hub or host). The 1500Ω resistor is internal to the EZ-USB.</p> <p>The EZ-USB accomplishes ReNumeration by selectively driving or floating the 3.3V supply to its internal 1500Ω resistor. When the supply is floated, the host no longer ‘sees’ the EZ-USB; it appears to have been disconnected from the USB. When the supply is then driven, the EZ-USB appears to have been newly connected to the USB. From the host’s point of view, the EZ-USB can be disconnected and reconnected to the USB, without ever physically disconnecting.</p> <p>The ‘connect state’ of EZ-USB is controlled by a register bit called DISCON (USBCS.3), which defaults to 0, or ‘connected’. This default may be overridden by setting the DISCON bit in the EEPROM configuration byte to 1, which allows the EZ-USB to come up ‘disconnected’. The EZ-USB core sees that this DISCON bit is set, and sets the USBCS.3 bit before the CPU is taken out of reset. The DISCON bit in the EEPROM configuration byte cannot be used to instruct the EZ-USB to connect to the USB bus. Once the CPU is running, firmware can modify this bit.</p>				
0	400KHZ (I2C bus speed)	<table border="0"> <tr> <td>0</td> <td>100 kHz</td> </tr> <tr> <td>1</td> <td>400 kHz</td> </tr> </table> <p>If 400KHZ = 0, the I2C bus operates at approximately 100 kHz. If 400KHZ = 1, the I2C bus operates at approximately 400 kHz. This bit is copied to I2CTL.0, whose default value is ‘0’, or 100 kHz. Once the CPU is running, firmware can modify this bit.</p>	0	100 kHz	1	400 kHz
0	100 kHz					
1	400 kHz					

3.6 The RENUM Bit

An EZ-USB control bit called 'RENUM' (ReNumerated) determines whether USB device requests over endpoint zero are handled by the Default USB Device or by EZ-USB firmware. At power-on reset, the RENUM bit (USBCS.1) is zero, indicating that the Default USB Device automatically handles USB device requests. Once firmware has been downloaded to the EZ-USB and the CPU is running, it can set RENUM = 1 so that subsequent device requests are handled by the downloaded firmware and descriptor tables. The [Endpoint Zero chapter on page 37](#) describes how the firmware handles device requests while RENUM = 1.

If a 128-pin EZ-USB is using off-chip code memory at 0x0000, the EA pin is high, and there is no boot EEPROM to supply a custom Vendor ID and Product ID, the EZ-USB automatically sets the RENUM bit to '1' so that device requests are always handled by the firmware and descriptor tables in the off-chip memory. The EZ-USB also sets RENUM = 1 after a 'C2 load' if the EA pin is low. In this case, firmware execution begins in on-chip RAM using the code loaded from the EEPROM, with the firmware handling all USB requests.

Another Use for the Default USB Device

The Default USB Device is established at power on to set up a USB device capable of downloading firmware into the EZ-USB's RAM. Another useful feature of the Default USB Device is that EZ-USB code can be written to support the already-configured generic USB device. Before bringing the CPU out of reset, the EZ-USB automatically enables certain endpoints and reports them to the host via descriptors. By using the Default USB Device (for example, by keeping RENUM = 0), the firmware can, with very little code, perform meaningful USB transfers that use these preconfigured endpoints. This accelerates the USB learning curve.

3.7 EZ-USB Response to Device Requests (RENUM = 0)

Table 3-7 shows how the Default USB Device responds to endpoint zero device requests when RENUM=0.

Table 3-7. How the Default USB Device Handles EP0 Requests When RENUM=0

bRequest	Name	EZ-USB Response
0x00	Get Status-Device	Returns two zero bytes
0x00	Get Status-Endpoint	Supplies EP Stall bit for indicated EP
0x00	Get Status-Interface	Returns two zero bytes
0x01	Clear Feature-Device	None
0x01	Clear Feature-Endpoint	Clears Stall bit for indicated EP
0x02	(reserved)	None

Table 3-7. How the Default USB Device Handles EP0 Requests When RENUM=0

bRequest	Name	EZ-USB Response
0x03	Set Feature Device	Sets TEST_MODE feature
0x03	Set Feature Endpoint	Sets Stall bit for indicated EP
0x04	(reserved)	None
0x05	Set Address	Updates FNADDR register
0x06	Get Descriptor	Supplies internal table
0x07	Set Descriptor	None
0x08	Get Configuration	Returns internal value
0x09	Set Configuration	Sets internal value
0x0A	Get Interface	Returns internal value (0-3)
0x0B	Set Interface	Sets internal value (0-3)
0x0C	Sync Frame	None
Vendor Requests		
0xA0	Firmware Load	Upload/Download on-chip RAM
0xA1-0xAF	Reserved	Reserved by Cypress Semiconductor
all other		None

A USB host enumerates by issuing Set Address, Get Descriptor, and Set Configuration (to '1') requests (the Set Address and Get Descriptor requests are used **only** during enumeration). After enumeration, the Default USB Device responds to the following device requests from the host:

- Set or clear an endpoint stall (Set/Clear Feature-Endpoint)
- Read the stall status for an endpoint (Get_Status-Endpoint)
- Set/Read an 8-bit configuration number (Set/Get Configuration)
- Set/Read a 2-bit interface alternate setting (Set/Get Interface)
- Download or upload EZ-USB on-chip RAM

3.8 EZ-USB Vendor Request for Firmware Load

Prior to ReNumeration, the host downloads data into the EZ-USB's internal RAM. The host can access two on-chip EZ-USB RAM spaces — Program / Data RAM at 0x0000-0x3FFF and Data RAM at 0xE000-0xE1FF — **which it can download or upload only when the CPU is held in reset**. The host must write to the CPUCS register to put the CPU in or out of reset. These two RAM spaces may also be boot-loaded by a 'C2' EEPROM connected to the I2C bus.

Note Off-chip RAM (on the 128-pin EZ-USB's address/data bus) cannot be uploaded or downloaded by the host using the 'Firmware Load' vendor request.

The USB Specification provides for 'vendor-specific requests' to be sent over endpoint zero. The EZ-USB uses

this feature to transfer data between the host and EZ-USB RAM. The EZ-USB automatically responds to two 'Firmware Load' requests, as shown in Table 3-8 and Table 3-9.

Table 3-8. Firmware Download

Byte	Field	Value	Meaning	EZ-USB Response
0	bmRequest	0x40	Vendor Request, OUT	None required
1	bRequest	0xA0	'Firmware Load'	
2	wValueL	AddrL	Starting Address	
3	wValueH	AddrH		
4	wIndexL	0x00		
5	wIndexH	0x00		
6	wLengthL	LenL	Number of Bytes	
7	wLengthH	LenH		

Note These upload and download requests are always handled by the EZ-USB, regardless of the state of the RENUM bit. The upload start address must be word-aligned (that is, the start address must be evenly divisible by two).

The bRequest value 0xA0 is reserved for this purpose. It should never be used for another vendor request. Cypress Semiconductor also reserves bRequest values 0xA1 through 0xAF; devices should not use these bRequest values.

A host loader program must write 0x01 to the CPUCS register to put the CPU into RESET, load all or part of the EZ-USB RAM with firmware, then reload the CPUCS register with '0' to take the CPU out of RESET. The CPUCS register (at 0xE600) is the only EZ-USB register that can be written using the Firmware Download command.

Table 3-9. Firmware Upload

Byte	Field	Value	Meaning	EZ-USB Response
0	bmRequest	0xC0	Vendor Request, IN	None required
1	bRequest	0xA0	'Firmware Load'	
2	wValueL	AddrL	Starting Address (must be word-aligned)	
3	wValueH	AddrH		
4	wIndexL	0x00		
5	wIndexH	0x00		
6	wLengthL	LenL	Number of Bytes	
7	wLengthH	LenH		

3.9 How the Firmware ReNumerates

Two control bits in the USBCS (USB Control and Status) register control the ReNumeration process: DISCON and RENUM.

Figure 3-2. USB Control and Status Register

USBCS		USB Control and Status						E680
b7	b6	b5	b4	b3	b2	b1	b0	
HSM	0	0	0	DISCON	NOSYNSOF	RENUM	SIGRSUME	
R/W	R	R	R	R/W	R/W	R/W	R/W	
0	0	0	0	0	1	0	0	

To simulate a USB disconnect, the firmware sets DISCON to '1'. To reconnect, the firmware clears DISCON to '0'.

Before reconnecting, the firmware sets or clears the RENUM bit to indicate whether the firmware or the Default USB Device handles device requests over endpoint zero: if RENUM = 0, the Default USB Device handles device requests; if RENUM = 1, the firmware does.

3.10 Multiple ReNumerations™

EZ-USB firmware can ReNumerate anytime. One use for this capability might be to 'fine tune' an isochronous endpoint's bandwidth requests by trying various descriptor values and ReNumerating.

4. Interrupts



4.1 Introduction

The EZ-USB's interrupt architecture is an enhanced and expanded version of the standard 8051's. The EZ-USB responds to the interrupts shown in [Table 4-1](#); interrupt sources that are not present in the standard 8051 are shown in **bold type**.

Table 4-1. EZ-USB Interrupts

EZ-USB Interrupt	Source	Interrupt Vector	Natural Priority
IE0	INT0# Pin	0x0003	1
TF0	Timer 0 Overflow	0x000B	2
IE1	INT1# Pin	0x0013	3
TF1	Timer 1 Overflow	0x001B	4
RI_0 & TI_0	USART0 Rx & Tx	0x0023	5
TF2	Timer 2 Overflow	0x002B	6
Resume	WAKEUP / WU2 Pin or USB Resume	0x0033	0
RI_1 & TI_1	USART1 Rx & Tx	0x003B	7
USBINT	USB	0x0043	8
I2CINT	I2C Bus	0x004B	9
IE4	GPIF / FIFOs / INT4 Pin	0x0053	10
IE5	INT5# Pin	0x005B	11
IE6	INT6 Pin	0x0063	12

The **Natural Priority** column in [Table 4-1](#) shows the EZ-USB interrupt priorities. The EZ-USB can assign each interrupt to a high or low priority group; priorities are resolved within the groups using the natural priorities.

4.2 SFRs

The following SFRs are associated with interrupt control:

- IE - SFR 0xA8 ([Table 4-2 on page 60](#))
- IP - SFR 0xB8 ([Table 4-3 on page 60](#))
- EXIF - SFR 0x91 ([Table 4-4 on page 60](#))
- EICON - SFR 0xD8 ([Table 4-5 on page 60](#))
- EIE - SFR 0xE8 ([Table 4-6 on page 60](#))
- EIP - SFR 0xF8 ([Table 4-7 on page 61](#))

The IE and IP SFRs provide interrupt enable and priority control for the standard interrupt unit, as with the standard 8051. Additionally, these SFRs provide control bits for the Serial Port 1 interrupt.

The EXIF, EICON, EIE and EIP registers provide flags, enable control, and priority control.

Interrupts

Table 4-2. IE Register — SFR 0xA8

Bit	Function
IE.7	EA - Global interrupt enable. Controls masking of all interrupts except USB wakeup (resume). EA = 0 disables all interrupts except USB wakeup. When EA = 1, interrupts are enabled or masked by their individual enable bits.
IE.6	ES1 - Enable Serial Port 1 interrupt. ES1 = 0 disables Serial Port 1 interrupts (TI_1 and RI_1). ES1 = 1 enables interrupts generated by the TI_1 or RI_1 flag.
IE.5	ET2 - Enable Timer 2 interrupt. ET2 = 0 disables Timer 2 interrupt (TF2). ET2=1 enables interrupts generated by the TF2 or EXF2 flag.
IE.4	ES0 - Enable Serial Port 0 interrupt. ES0 = 0 disables Serial Port 0 interrupts (TI_0 and RI_0). ES0=1 enables interrupts generated by the TI_0 or RI_0 flag.
IE.3	ET1 - Enable Timer 1 interrupt. ET1 = 0 disables Timer 1 interrupt (TF1). ET1=1 enables interrupts generated by the TF1 flag.
IE.2	EX1 - Enable external interrupt 1. EX1 = 0 disables external interrupt 1 (IE1). EX1=1 enables interrupts generated by the INT1# pin.
IE.1	ET0 - Enable Timer 0 interrupt. ET0 = 0 disables Timer 0 interrupt (TF0). ET0=1 enables interrupts generated by the TF0 flag.
IE.0	EX0 - Enable external interrupt 0. EX0 = 0 disables external interrupt 0 (IE0). EX0=1 enables interrupts generated by the INT0# pin.

Table 4-3. IP Register — SFR 0xB8

Bit	Function
IP.7	Reserved. Read as '1'.
IP.6	PS1 - Serial Port 1 interrupt priority control. PS1 = 0 sets Serial Port 1 interrupt (TI_1 or RI_1) to low priority. PS1 = 1 sets Serial port 1 interrupt to high priority.
IP.5	PT2 - Timer 2 interrupt priority control. PT2 = 0 sets Timer 2 interrupt (TF2) to low priority. PT2 = 1 sets Timer 2 interrupt to high priority.
IP.4	PS0 - Serial Port 0 interrupt priority control. PS0 = 0 sets Serial Port 0 interrupt (TI_0 or RI_0) to low priority. PS0 = 1 sets Serial Port 0 interrupt to high priority.
IP.3	PT1 - Timer 1 interrupt priority control. PT1 = 0 sets Timer 1 interrupt (TF1) to low priority. PT1 = 1 sets Timer 1 interrupt to high priority.
IP.2	PX1 - External interrupt 1 priority control. PX1 = 0 sets external interrupt 1 (IE1) to low priority. PT1 = 1 sets external interrupt 1 to high priority.
IP.1	PT0 - Timer 0 interrupt priority control. PT0 = 0 sets Timer 0 interrupt (TF0) to low priority. PT0 = 1 sets Timer 0 interrupt to high priority.
IP.0	PX0 - External interrupt 0 priority control. PX0 = 0 sets external interrupt 0 (IE0) to low priority. PX0 = 1 sets external interrupt 0 to high priority.

Table 4-4. EXIF Register — SFR 0x91

Bit	Function
EXIF.7	IE5 - External Interrupt 5 flag. IE5 = 1 indicates a falling edge was detected at the INT5# pin. IE5 must be cleared by software. Setting IE5 in software generates an interrupt, if enabled.
EXIF.6	IE4 - GPIF/FIFO/External Interrupt 4 flag. The 'INT4' interrupt is internally connected to the FIFO/GPIF interrupt by default; it can optionally function as External Interrupt 4 on the 100- and 128-pin EZ-USB. When configured as External Interrupt 4, IE4 indicates that a rising edge was detected at the INT4 pin. IE4 must be cleared by software. Setting IE4 in software generates an interrupt, if enabled.
EXIF.5	I2CINT - I2C Bus Interrupt flag. I2CINT = 1 indicates an I2C Bus interrupt. I2CINT must be cleared by software. Setting I2CINT in software generates an interrupt, if enabled.
EXIF.4	USBINT - USB Interrupt flag. USBINT = 1 indicates an USB interrupt. USBINT must be cleared by software. Setting USBINT in software generates an interrupt, if enabled.
EXIF.3	Reserved. Read as '1'.
EXIF.2-0	Reserved. Read as '0'.

Table 4-5. EICON Register — SFR 0xD8

Bit	Function
EICON.7	SMOD1 - Serial Port 1 baud rate doubler enable. When SMOD1 = 1, the baud rate for Serial Port 1 is doubled.
EICON.6	Reserved. Read as '1'.
EICON.5	ERESI - Enable Resume interrupt. ERESI = 0 disables the Resume interrupt. ERESI = 1 enables interrupts generated by the resume event.
EICON.4	RESI - Wakeup interrupt flag. RESI = 1 indicates a false-to-true transition was detected at the WAKEUP or WU2 pin, or that USB activity has resumed from the suspended state. RESI must be cleared by software before exiting the interrupt service routine, otherwise the interrupt is immediately be reasserted. Setting RESI = 1 in software generates a wakeup interrupt, if enabled.
EICON.3	INT6 - External interrupt 6. When INT6 = 1, the INT6 pin has detected a low to high transition. INT6 must be cleared by software. Setting this bit in software generates an IE6 interrupt, if enabled.
EICON.2-0	Reserved. Read as '0'.

Table 4-6. EIE Register — SFR 0xE8

Bit	Function
EIE.7-5	Reserved. Read as '1'.
EIE.4	EX6 - Enable external interrupt 6. EX6 = 0 disables external interrupt 6 (IE6). EX6 = 1 enables interrupts generated by the INT6 pin.

Table 4-6. EIE Register — SFR 0xE8

Bit	Function
EIE.3	EX5 - Enable external interrupt 5. EX5 = 0 disables external interrupt 5 (IE5). EX5 = 1 enables interrupts generated by the INT5# pin.
EIE.2	EX4 - Enable external interrupt 4. EX4 = 0 disables external interrupt 4 (IE4). EX4 = 1 enables interrupts generated by the INT4 pin or by the FIFO/GPIF Interrupt.
EIE.1	EI2C - Enable I2C bus interrupt (I2CINT). EI2C = 0 disables the I2C Bus interrupt. EI2C = 1 enables interrupts generated by the I2C bus controller.
EIE.0	EUSB - Enable USB interrupt (USBINT). EUSB = 0 disables USB interrupts. EUSB = 1 enables interrupts generated by the USB Interface.

Table 4-7. EIP Register — SFR 0xF8

Bit	Function
EIP.7-5	Reserved. Read as '1'.
EIP.4	PX6 - External interrupt 6 priority control. PX6 = 0 sets external interrupt 6 (IE6) to low priority. PX6 = 1 sets external interrupt 6 to high priority.
EIP.3	PX5 - External interrupt 5 priority control. PX5 = 0 sets external interrupt 5 (IE5) to low priority. PX5=1 sets external interrupt 5 to high priority.
EIP.2	PX4 - External interrupt 4 priority control. PX4 = 0 sets external interrupt 4 (INT4 / GPIF / FIFO) to low priority. PX4=1 sets external interrupt 4 to high priority.
EIP.1	PI2C - I2CINT priority control. PI2C = 0 sets I2C Bus interrupt to low priority. PI2C=1 sets I2C Bus interrupt to high priority.
EIP.0	PUSB - USBINT priority control. PUSB = 0 sets USB interrupt to low priority. PUSB=1 sets USB interrupt to high priority.

4.2.1 803x/805x Compatibility

The implementation of interrupts is similar to that of the Dallas Semiconductor DS80C320. [Table 4-8](#) summarizes the differences in interrupt implementation between the Intel 8051, the Dallas Semiconductor DS80C320, and the EZ-USB.

Table 4-8. Summary of Interrupt Compatibility

Feature	Intel 8051	Dallas DS80C320	Cypress EZ-USB
Power Fail Interrupt	Not implemented	Internally generated	Replaced with RESUME Interrupt
External Interrupt 0	Implemented	Implemented	Implemented
Timer 0 Interrupt	Implemented	Implemented	Implemented
External Interrupt 1	Implemented	Implemented	Implemented
Timer 1 Interrupt	Implemented	Implemented	Implemented
Serial Port 0 Interrupt	Implemented	Implemented	Implemented
Timer 2 Interrupt	Not implemented	Implemented	Implemented
Serial Port 1 Interrupt	Not implemented	Implemented	Implemented
External Interrupt 2	Not implemented	Implemented	Replaced with autovectorized USB Interrupt
External Interrupt 3	Not implemented	Implemented	Replaced with I2C Bus Interrupt
External Interrupt 4	Not implemented	Implemented	Replaced by autovectorized FIFO/GPIF Interrupt. Can be configured as External Interrupt 4 on 100- and 128-pin EZ-USB only.
External Interrupt 5	Not implemented	Implemented	Implemented
Watchdog Timer Interrupt	Not implemented	Internally generated	Replaced with External Interrupt 6
Real-time Clock Interrupt	Not implemented	Implemented	Not implemented

4.3 Interrupt Processing

When an enabled interrupt occurs, the EZ-USB completes the instruction it is currently executing, then vectors to the address of the interrupt service routine (ISR) associated with that interrupt (see [Table 4-9 on page 62](#)). The EZ-USB executes the ISR to completion unless another interrupt of higher priority occurs. Each ISR ends with a `RETI` (return from interrupt) instruction. After executing the `RETI`, the EZ-USB continues executing firmware at the instruction following the one which was executing when the interrupt occurred.

Note The EZ-USB always completes the instruction in progress before servicing an interrupt. If the instruction in progress is `RETI`, or a write access to any of the IP, IE, EIP, or EIE SFRs, the EZ-USB completes one additional instruction before servicing the interrupt.

Table 4-9. Interrupt Flags, Enables, Priority Control, and Vectors

Interrupt	Description	Interrupt Request Flag	Interrupt Enable	Assigned Priority Control	Natural Priority	Interrupt Vector
RESUME	Resume interrupt	EICON.4	EICON.5	Always Highest	0 (highest)	0x0033
IE0	External interrupt 0	TCON.1	IE.0	IP.0	1	0x0003
TF0	Timer 0 interrupt	TCON.5	IE.1	IP.1	2	0x000B
IE1	External interrupt 1	TCON.3	IE.2	IP.2	3	0x0013
TF1	Timer 1 interrupt	TCON.7	IE.3	IP.3	4	0x001B
TI_0 or RI_0	Serial port 0 transmit or receive interrupt	SCON0.1 (TI_0) SCON0.0 (RI_0)	IE.4	IP.4	5	0x0023
TF2 or EXF2	Timer 2 interrupt	T2CON.7 (TF2) T2CON.6 (EXF2)	IE.5	IP.5	6	0x002B
TI_1 or RI_1	Serial port 1 transmit or receive interrupt	SCON1.1 (TI_1) SCON1.0 (RI_1)	IE.6	IP.6	7	0x003B
USBINT	Autovectored USB interrupt	EXIF.4	EIE.0	EIP.0	8	0x0043
I2CINT	I2C Bus interrupt	EXIF.5	EIE.1	EIP.1	9	0x004B
IE4	Autovectored FIFO / GPIF or External interrupt 4	EXIF.6	EIE.2	EIP.2	10	0x0053
IE5	External interrupt 5	EXIF.7	EIE.3	EIP.3	11	0x005B
IE6	External interrupt 6	EICON.3	EIE.4	EIP.4	12	0x0063

4.3.1 Interrupt Masking

The EA Bit in the IE SFR (IE.7) is a global enable for all interrupts except the RESUME (USB wakeup) interrupt, which is always enabled. When EA = 1, each interrupt is enabled or masked by its individual enable bit. When EA = 0, all interrupts are masked except the USB wakeup interrupt.

[Table 4-9](#) provides a summary of interrupt sources, flags, enables, and priorities.

4.3.1.1 Interrupt Priorities

There are two stages of interrupt priority: assigned interrupt level and natural priority. Assigned priority is set by EZ-USB firmware; natural priority is as shown in [Table 4-9](#), and is fixed.

Note The assigned interrupt level (highest, high, or low) takes precedence over natural priority.

The RESUME (USB wakeup) interrupt always has highest assigned priority and is the only interrupt that can have high-

est assigned priority. All other interrupts can be assigned either high or low priority.

In addition to an assigned priority level (high or low), each interrupt also has a natural priority, as listed in [Table 4-9](#). ‘Simultaneous’ interrupts with the same assigned priority level (for example, both high) are resolved according to their natural priority. For example, if INT0 and INT1 are both assigned high priority and both occur simultaneously, INT0 takes precedence due to its higher natural priority.

Once an interrupt is being serviced, only an interrupt of higher ‘assigned’ priority level can interrupt the service routine. That is, an ISR for a low-assigned-level interrupt can only be interrupted by a high-assigned-level interrupt. An ISR for a high-assigned-level interrupt can only be interrupted by the RESUME interrupt.

4.3.2 Interrupt Sampling

The internal timers and serial ports generate interrupts by setting the interrupt flag bits shown in [Table 4-9](#). These interrupts are sampled once per instruction cycle (that is, once every 4 CLKOUT cycles).

INT0# and INT1# are both active low and can be programmed to be either edge-sensitive or level-sensitive, through the IT0 and IT1 bits in the TCON SFR. When ITx = 0, INTx# is level-sensitive and the EZ-USB sets the IEx flag when the INTx# pin is sampled low. When ITx = 1, INTx# is edge-sensitive and the EZ-USB sets the IEx flag when the INTx# pin is sampled high then low on consecutive samples.

The remaining five interrupts (INT 4-6, USB and I2C Bus interrupts) are edge-sensitive only. INT6 and INT4 are active high and INT5# is active low.

To ensure that edge-sensitive interrupts are detected, the interrupt pins should be held in each state for a minimum of one instruction cycle (4 CLKOUT cycles). Level-sensitive interrupts are not latched; their pins must remain asserted until the interrupt is serviced.

4.3.3 Interrupt Latency

Interrupt response time depends on the current state of the EZ-USB. The fastest response time is five instruction cycles: one to detect the interrupt, and four to perform the LCALL to the ISR.

The maximum latency is 13 instruction cycles. This 13-cycle latency occurs when the EZ-USB is currently executing a RETI instruction followed by a MUL or DIV instruction. The 13 instruction cycles in this case are: one to detect the interrupt, three to complete the RETI, five to execute the DIV or MUL, and four to execute the LCALL to the ISR.

This 13-instruction-cycle latency excludes autovector latency for the USB and FIFO/GPIF interrupts (see sections 4.5 USB-Interrupt Autovectors on page 67 and 4.8 FIFO/GPIF Interrupt Autovectors on page 69), and any instructions required to perform housekeeping, as shown in Figure 4-2 on page 65. Autovectoring adds a fixed four-instruction cycle, so the maximum latency for an autovectored USB or FIFO/GPIF interrupt is 13 + 4 = 17 instruction cycles.

4.4 USB-Specific Interrupts

The EZ-USB provides 28 USB-specific interrupts. One, 'Resume', has its own dedicated interrupt; the other 27 share the 'USB' interrupt.

4.4.1 Resume Interrupt

After the EZ-USB has entered its idle state, it responds to an external signal on its WAKEUP/WU2 pins or resumption of USB bus activity by restarting its oscillator and resuming firmware execution.

The Power Management chapter on page 77 describes suspend/resume signaling in detail, and presents an example which uses the Wakeup Interrupt.

4.4.2 USB Interrupts

Table 4-10 shows the 27 USB requests that share the USB Interrupt. Those marked with an asterisk are not implemented in FX1. Figure 4-1 on page 64 shows the USB Interrupt logic; the bottom IRQ, EP8ISOERR, is expanded in the diagram to show the logic which is associated with each USB interrupt request.

Table 4-10. Individual USB Interrupt Sources

Priority	INT2VEC Value	Source	Notes
1	00	SUDAV	SETUP Data Available
2	04	SOF	Start of Frame (or microframe)
3	08	SUTOK	Setup Token Received
4	0C	SUSPEND	USB Suspend request
5	10	USB RESET	Bus reset
6	14	HISPEED	Entered high-speed operation*
7	18	EP0ACK	EZ-USB ACK'd the CONTROL Handshake
8	1C	reserved	
9	20	EP0-IN	EP0-IN ready to be loaded with data
10	24	EP0-OUT	EP0-OUT has USB data
11	28	EP1-IN	EP1-IN ready to be loaded with data
12	2C	EP1-OUT	EP1-OUT has USB data
13	30	EP2	IN: buffer available. OUT: buffer has data
14	34	EP4	IN: buffer available. OUT: buffer has data
15	38	EP6	IN: buffer available. OUT: buffer has data
16	3C	EP8	IN: buffer available. OUT: buffer has data
17	40	IBN	IN-Bulk-NAK (any IN endpoint)
18	44	reserved	
19	48	EP0PING	EP0 OUT was Pinged and it NAK'd*
20	4C	EP1PING	EP1 OUT was Pinged and it NAK'd*
21	50	EP2PING	EP2 OUT was Pinged and it NAK'd*
22	54	EP4PING	EP4 OUT was Pinged and it NAK'd*
23	58	EP6PING	EP6 OUT was Pinged and it NAK'd*
24	5C	EP8PING	EP8 OUT was Pinged and it NAK'd*
25	60	ERRLIMIT	Bus errors exceeded the programmed limit
26	64	reserved	
27	68	reserved	
28	6C	reserved	
29	70	EP2ISOERR	ISO EP2 OUT PID sequence error
30	74	EP4ISOERR	ISO EP4 OUT PID sequence error
31	78	EP6ISOERR	ISO EP6 OUT PID sequence error
32	7C	EP8ISOERR	ISO EP8 OUT PID sequence error

Figure 4-1. USB Interrupts

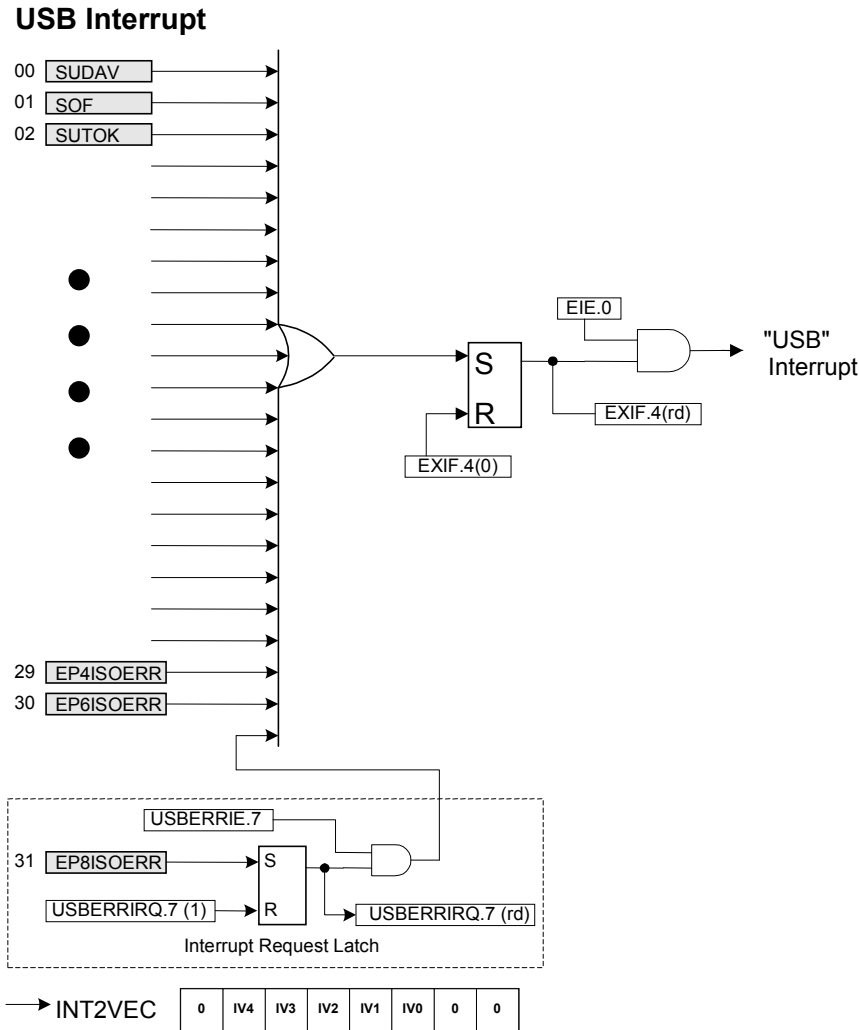

Referring to the logic inside the dotted lines of [Figure 4-1](#), each USB interrupt source has an interrupt request latch. IRQ bits are set automatically by the EZ-USB; firmware clears an IRQ bit by writing a '1' to it. The output of each latch is ANDed with an Interrupt Enable Bit and then ORed with all the other USB Interrupt request sources.

The EZ-USB prioritizes the USB interrupts and constructs an Autovector, which appears in the INT2VEC register. The interrupt vector values IV[4:0] are shown to the left of the interrupt sources (shaded boxes in [Figure 4-1](#)); zero is the highest priority, 31 is the lowest. If two USB interrupts occur simultaneously, the prioritization affects which one is first indicated in the INT2VEC register.

If Autovectoring is enabled, the INT2VEC byte replaces the contents of address 0x0045 in the EZ-USB's program memory. This causes the EZ-USB to automatically vector to a different address for each USB interrupt source. This

mechanism is explained in detail in section [4.5 USB-Interrupt Autovectors on page 67](#).

Due to the OR gate in [Figure 4-1](#), assertion of any of the individual USB interrupt sources sets the EZ-USB's 'main' USB Interrupt request bit (EXIF.4). This main USB interrupt is enabled by setting EIE.0 to '1'.

To clear the main USB interrupt request, firmware clears the EXIF.4 bit to '0'.

After servicing a USB interrupt, EZ-USB firmware clears the individual USB source's IRQ bit by setting it to '1'. If any other USB interrupts are pending, the act of clearing the IRQ bit causes the EZ-USB to generate another pulse for the highest-priority pending interrupt. If more than one is pending, each is serviced in the priority order shown in [Figure 4-1](#), starting with SUDAV (priority 00) as the highest priority, and ending with EP8ISOERR (priority 31) as the lowest.

Note The main USB interrupt request is cleared by clearing the EXIF.4 bit to '0'; each individual USB interrupt is cleared by setting its IRQ bit to '1'.

Note It is important in any USB Interrupt Service Routine (ISR) to clear the main USB Interrupt before clearing the individual USB interrupt request latch. This is because as

soon as the individual USB interrupt is cleared, any pending USB interrupt immediately tries to generate another main USB Interrupt. If the main USB IRQ bit has not been previously cleared, the pending interrupt is lost.

Figure 4-2 illustrates a typical USB ISR.

Figure 4-2. The Order of Clearing Interrupt Requests is Important

```

USB_ISR:    push    dps
            push    dpl
            push    dph
            push    dpl1
            push    dph1
            push    acc
;
            mov     a,EXIF           ; FIRST clear the USB (INT2) interrupt request
            clr     acc.4
            mov     EXIF,a          ; Note: EXIF reg is not bit-addressable
;
            mov     dptr,#USBERRIRQ ; now clear the USB interrupt request
            mov     a,#10000000b    ; use EP8ISOERR as example
            movx    @dptr,a
;
; (service the interrupt here)
;
            pop     acc
            pop     dph1
            pop     dpl1
            pop     dph
            pop     dpl
            pop     dps
;
            reti

```

The registers associated with the individual USB interrupt sources are described in the [Registers chapter on page 211](#) and [section 8.6 CPU Control of EZ-USB Endpoints on page 89](#). Each interrupt source has an enable (IE) and a request (IRQ) bit. Firmware sets the IE bit to '1' to enable the interrupt. The EZ-USB sets an IRQ bit to '1' to request an interrupt, and the firmware clears an IRQ bit by writing a '1' to it.

4.4.2.1 SUTOK, SUDAV Interrupts

Figure 4-3. SUTOK and SUDAV Interrupts

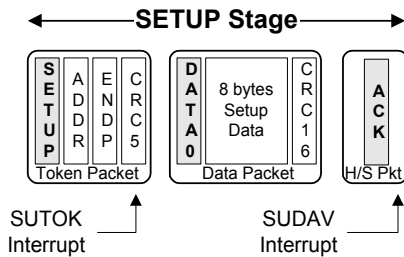

SUTOK and SUDAV are supplied to the EZ-USB by CONTROL endpoint zero. The first portion of a USB CONTROL transfer is the SETUP stage shown in Figure 4-3 (a full CONTROL transfer is shown in Figure 2-1 on page 38). When the EZ-USB decodes a SETUP packet, it asserts the SUTOK (SETUP Token) Interrupt Request. After the EZ-USB has received the eight bytes error-free and copied them into the eight internal registers at SETUPDAT, it asserts the SUDAV Interrupt Request.

Firmware responds to the SUDAV Interrupt by reading the eight SETUP data bytes in order to decode the USB request. See chapter “Endpoint Zero” on page 37.

The SUTOK Interrupt is provided to give advance warning that the eight register bytes at SETUPDAT are about to be overwritten. It is useful for debug and diagnostic purposes.

4.4.2.2 SOF Interrupt

Figure 4-4. A Start Of Frame (SOF) Packet

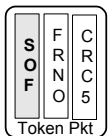

A USB Start-of-Frame Interrupt Request is asserted when the host sends a Start of Frame (SOF) packet. SOFs occur once per millisecond in full-speed (12 Mbits/sec) mode, and once every 125 microseconds in high-speed (480 Mbits/sec) mode.

When the EZ-USB receives an SOF packet, it copies the eleven-bit frame number (FRNO in Figure 4-4) into the USB-FRAMEH:L registers and asserts the SOF Interrupt Request. Isochronous endpoint data may be serviced via the SOF Interrupt.

4.4.2.3 Suspend Interrupt

If the EZ-USB detects a ‘suspend’ condition from the host, it asserts the SUSP (Suspend) Interrupt Request. A full

description of Suspend-Resume signaling appears in the Power Management chapter on page 77.

4.4.2.4 USB RESET Interrupt

The USB host signals a bus reset by driving both D+ and D-low for at least 10 ms. When the EZ-USB detects the onset of USB bus reset, it asserts the URES Interrupt Request.

4.4.2.5 HISPEED Interrupt (FX2LP only)

This interrupt is asserted when the host grants high-speed (480 Mbps) access to the FX2LP.

4.4.2.6 EP0ACK Interrupt

This interrupt is asserted when the EZ-USB has acknowledged the STATUS stage of a CONTROL transfer on endpoint 0.

4.4.2.7 Endpoint Interrupts

These interrupts are asserted when an endpoint requires service.

For an OUT endpoint, the interrupt request signifies that OUT data has been sent from the host, validated by the EZ-USB, and is in the endpoint buffer memory.

For an IN endpoint, the interrupt request signifies that the data previously loaded by the EZ-USB into the IN endpoint buffer has been read and validated by the host, making the IN endpoint buffer ready to accept new data.

Table 4-11. Endpoint Interrupts

Interrupt Name	Description
EP0-IN	EP0-IN ready to be loaded with data (BUSY bit 1-to-0)
EP0-OUT	EP0-OUT has received USB data (BUSY bit 1-to-0)
EP1-IN	EP1-IN ready to be loaded with data (BUSY bit 1-to-0)
EP1-OUT	EP1-OUT has received USB data (BUSY bit 1-to-0)
EP2	IN: Buffer available (Empty Flag 1-to-0) OUT: Buffer has received USB data (Empty Flag 0-to-1)
EP4	IN: Buffer available (Empty Flag 1-to-0) OUT: Buffer has received USB data (Empty Flag 0-to-1)
EP6	IN: Buffer available (Empty Flag 1-to-0) OUT: Buffer has received USB data (Empty Flag 0-to-1)
EP8	IN: Buffer available (Empty Flag 1-to-0) OUT: Buffer has received USB data (Empty Flag 0-to-1)

4.4.2.8 In-Bulk-NAK (IBN) Interrupt

When the host sends an IN token to any IN endpoint which does not have data to send, the EZ-USB automatically NAKs the IN token and asserts this interrupt.

4.4.2.9 EPxPING Interrupt (FX2LP only)

These interrupts are active only during high-speed (480 Mbits/sec) operation.

High-speed USB implements a PING-NAK mechanism for OUT transfers. When the host wishes to send OUT data to an endpoint, it first sends a PING token to see if the endpoint is ready (for example, if it has an empty buffer). If a buffer is not available, the FX2LP returns a NAK handshake. PING-NAK transactions continue to occur until an OUT buffer is available, at which time the FX2LP answers a PING with an ACK handshake and the host sends the OUT data to the endpoint.

The EPxPING interrupt is asserted when the host PINGs an endpoint and the FX2LP responds with a NAK because no endpoint buffer memory is available.

4.4.2.10 ERRLIMIT Interrupt

This interrupt is asserted when the USB error-limit counter has exceeded the preset error limit threshold. See section 8.6.3.3 USBERRIE, USBERRIRQ, ERRCNTLM, CLRERRCNT on page 94 for full details.

4.4.2.11 EPxISOERR Interrupt

These interrupts are asserted when an ISO data PID is missing or arrives out of sequence, or when an ISO packet is dropped because no buffer space is available (to receive an OUT packet).

4.5 USB-Interrupt Autovectors

The main USB interrupt is shared by 27 interrupt sources. To save the code and processing time which normally would be required to identify the individual USB interrupt source, the EZ-USB provides a second level of interrupt vectoring, called 'Autovectoring.' When a USB interrupt is asserted, the EZ-USB pushes the program counter onto its stack then jumps to address 0x0043, where it expects to find a 'jump' instruction to the USB Interrupt service routine.

The EZ-USB jump instruction is encoded as follows:

Table 4-12. EZ-USB Jump Instruction

Address	Op-Code	Hex Value
0x0043	LJMP	0x02
0x0044	AddrH	0xHH
0x0045	AddrL	0xLL

If Autovectoring is enabled (AV2EN=1 in the INTSETUP register), the EZ-USB substitutes its INT2VEC byte (see Table 4-10 on page 63) for the byte at address 0x0045. Therefore, if the high byte ('page') of a jump-table address is preloaded at location 0x0044, the automatically-inserted INT2VEC byte at 0x0045 directs the jump to the correct address out of the 27 addresses within the page.

As shown in Table 4-13, the jump table contains a series of jump instructions, one for each individual USB Interrupt source's ISR.

Table 4-13. A Typical USB-Interrupt Jump Table

Table Offset	Instruction
0x00	LJMP SUDAV_ISR
0x04	LJMP SOF_ISR
0x08	LJMP SUTOK_ISR
0x0C	LJMP SUSPEND_ISR
0x10	LJMP USBRESET_ISR
0x14	LJMP HISPEED_ISR
0x18	LJMP EP0ACK_ISR
0x1C	LJMP SPARE_ISR
0x20	LJMP EP0IN_ISR
0x24	LJMP EP0OUT_ISR
0x28	LJMP EP1IN_ISR
0x2C	LJMP EP1OUT_ISR
0x30	LJMP EP2_ISR
0x34	LJMP EP4_ISR
0x38	LJMP EP6_ISR
0x3C	LJMP EP8_ISR
0x40	LJMP IBN_ISR
0x44	LJMP SPARE_ISR
0x48	LJMP EP0PING_ISR
0x4C	LJMP EP1PING_ISR
0x50	LJMP EP2PING_ISR
0x54	LJMP EP4PING_ISR
0x58	LJMP EP6PING_ISR
0x5C	LJMP EP8PING_ISR
0x60	LJMP ERRLIMIT_ISR
0x64	LJMP SPARE_ISR
0x68	LJMP SPARE_ISR
0x6C	LJMP SPARE_ISR
0x70	LJMP EP2ISOERR_ISR
0x74	LJMP EP2ISOERR_ISR
0x78	LJMP EP2ISOERR_ISR
0x7C	LJMP EP2ISOERR_ISR

Figure 4-5. The USB Autovector Mechanism in Action

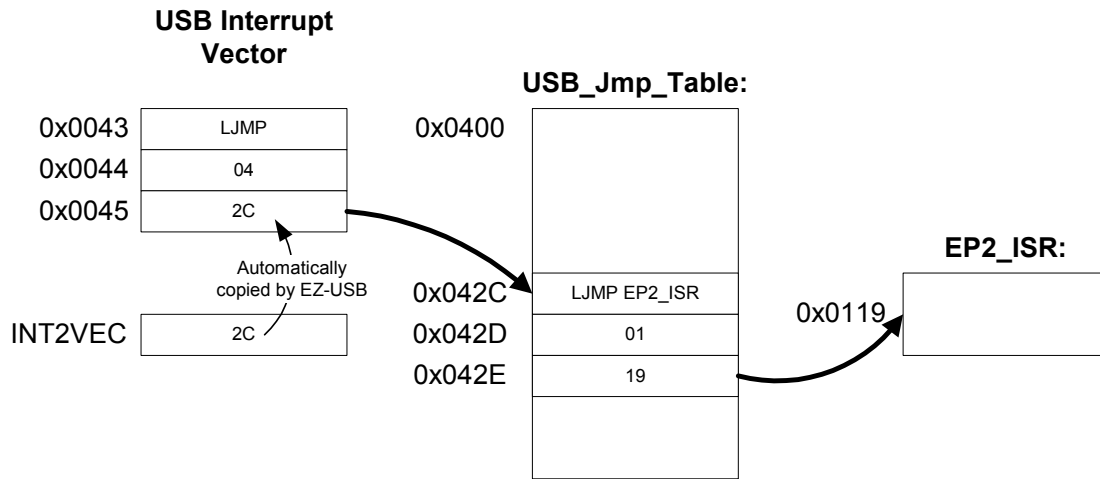

4.5.1 USB Autovector Coding

To employ autovectoring for the USB interrupt:

1. Insert a jump instruction at 0x0043 to a table of jump instructions to the various USB interrupt service routines. Make sure the jump table starts on a 0x0100-byte page boundary.
2. Code the jump table with jump instructions to each individual USB interrupt service routine. This table has two important requirements, arising from the format of the INT2VEC Byte (zero-based, with the two LSBs set to '0'):
 - a. It must begin on a page boundary (address 0xnn00)
 - b. The jump instructions must be four bytes apart.
3. The interrupt service routines can be placed anywhere in memory.

4. Write initialization code to enable the USB interrupt (INT2) and Autovectoring.

Figure 4-5 illustrates an ISR that services endpoint 2. When endpoint 2 requires service, the EZ-USB asserts the USB interrupt request, vectoring to location 0x0043.

The jump instruction at this location, which was originally coded as 'LJMPC 0400', becomes 'LJMPC 042C' because the EZ-USB automatically inserts 2C, the INT2VEC value for EP2 (Table 4-13 on page 67).

The EZ-USB jumps to 0x042C, where it executes the jump instruction to the EP2 ISR, arbitrarily located for this example at address 0x0119.

Once the EZ-USB vectors to 0x0043, initiation of the endpoint-specific ISR takes only eight instruction cycles.

4.6 I²C Bus Interrupt

Figure 4-6. I²C Bus Interrupt Enable Bits and Registers

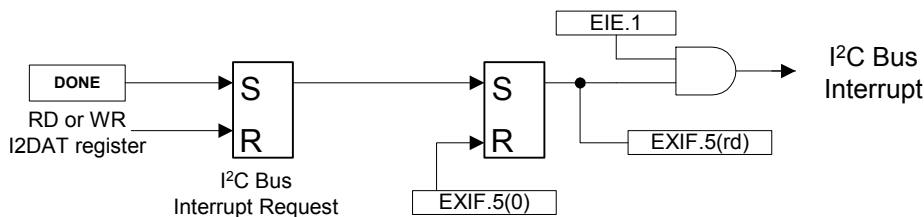

I2CS 0xE678	START	STOP	LASTRD	ID1	ID0	BERR	ACK	DONE
----------------	-------	------	--------	-----	-----	------	-----	------

I2DAT 0xE679	D7	D6	D5	D4	D3	D2	D1	D0
-----------------	----	----	----	----	----	----	----	----

The [Input/Output chapter on page 181](#) describes the interface to the EZ-USB's I2C Bus controller. The EZ-USB uses two registers, I2CS (Control and Status) and I2DAT (Data), to transfer data over the bus.

An I2C Bus Interrupt is asserted whenever one of the following occurs:

- The DONE bit (I2CS.0) makes a zero-to-one transition, signaling that the bus controller is ready for another command
- The STOP bit (I2CS.6) makes a one-to-zero transition

To enable the 'Done' interrupt source, set EIE.1 to '1'; to additionally enable the 'Stop' interrupt source, set STOPIE to '1'. If both interrupts are enabled, the interrupt source may be determined by checking the DONE and STOP bits in the I2CS register.

To reset the Interrupt Request, write a zero to EXIF.5. Any firmware read or write to the I2DAT or I2CS register also automatically clears the Interrupt Request.

Note Firmware must make sure the STOP bit is zero before writing to I2CS or I2DAT.

4.7 FIFO/GPIF Interrupt (INT4)

Just as the USB Interrupt is shared among 27 individual USB-interrupt sources, the FIFO/GPIF interrupt is shared among 14 individual FIFO/GPIF sources.

The FIFO/GPIF Interrupt, like the USB Interrupt, can employ autovectoring. [Table 4-14](#) shows the priority and INT4VEC values for the 14 FIFO/GPIF interrupt sources.

Table 4-14. Individual FIFO/GPIF Interrupt Sources

Priority	INT4VEC Value	Source	Notes
1	80	EP2PF	Endpoint 2 Programmable Flag
2	84	EP4PF	Endpoint 4 Programmable Flag
3	88	EP6PF	Endpoint 6 Programmable Flag
4	8C	EP8PF	Endpoint 8 Programmable Flag
5	90	EP2EF	Endpoint 2 Empty Flag
6	94	EP4EF	Endpoint 4 Empty Flag
7	98	EP6EF	Endpoint 6 Empty Flag
8	9C	EP8EF	Endpoint 8 Empty Flag
9	A0	EP2FF	Endpoint 2 Full Flag
10	A4	EP4FF	Endpoint 4 Full Flag
11	A8	EP6FF	Endpoint 6 Full Flag
12	AC	EP8FF	Endpoint 8 Full Flag
13	B0	GPIFDONE	GPIF Operation Complete (See General Programmable Interface, on page 121)
14	B4	GPIFWF	GPIF Waveform (See General Programmable Interface, on page 121)

When FIFO/GPIF interrupt sources are asserted, the EZ-USB prioritizes them and constructs an Autovector, which appears in the INT4VEC register; '0' is the highest priority, '14' is the lowest. If two FIFO/GPIF interrupts occur simultaneously, the prioritization affects which one is first indicated in the INT4VEC register. If Autovectoring is enabled, the INT4VEC byte replaces the contents of address 0x0055 in the EZ-USB's program memory. This causes the EZ-USB to automatically vector to a different address for each FIFO/GPIF interrupt source. This mechanism is explained in detail in [section 4.8 FIFO/GPIF Interrupt Autovectors](#).

Note It is important in any FIFO/GPIF Interrupt Service Routine (ISR) to clear the main INT4 Interrupt before clearing the individual FIFO/GPIF interrupt request latch. This is because as soon as the individual FIFO/GPIF interrupt is cleared, any pending individual FIFO/GPIF interrupt immediately tries to generate another main INT4 Interrupt. If the main INT4 IRQ bit has not been previously cleared, the pending interrupt is lost.

The registers associated with the individual FIFO/GPIF interrupt sources are described in the [Registers chapter on page 211](#) and in [section 8.6 CPU Control of EZ-USB Endpoints on page 89](#). Each interrupt source has an enable (IE) and a request (IRQ) bit. Firmware sets the IE bit to '1' to enable the interrupt. The EZ-USB sets an IRQ bit to '1' to request an interrupt, and the firmware clears an IRQ bit by setting it to '1'.

Note The main FIFO/GPIF interrupt request is cleared by clearing the EXIF.6 bit to '0'; each individual FIFO/GPIF interrupt is cleared by setting its IRQ bit to '1'.

4.8 FIFO/GPIF Interrupt Autovectors

The main FIFO/GPIF interrupt is shared by 14 interrupt sources. To save the code and processing time which normally is required to sort out the individual FIFO/GPIF interrupt source, the EZ-USB provides a second level of interrupt vectoring, called *Autovectoring*. When a FIFO/GPIF interrupt is asserted, the EZ-USB pushes the program counter onto its stack then jumps to address 0x0053, where it expects to find a 'jump' instruction to the FIFO/GPIF Interrupt service routine.

The EZ-USB jump instruction is encoded as follows:

Table 4-15. EZ-USB JUMP Instruction

Address	Op-Code	Hex Value
0x0053	LJMP	0x02
0x0054	AddrH	0xHH
0x0055	AddrL	0xLL

If Autovectoring is enabled (AV4EN=1 in the INTSETUP register), the EZ-USB substitutes its INT4VEC byte (see [Table 4-14 on page 69](#)) for the byte at address 0x0055.

Therefore, if the high byte ('page') of a jump-table address is preloaded at location 0x0054, the automatically-inserted INT4VEC byte at 0x0055 directs the jump to the correct address out of the 14 addresses within the page.

As shown in Table 4-16, the jump table contains a series of jump instructions, one for each individual FIFO/GPIF Interrupt source's ISR.

Table 4-16. A Typical FIFO/GPIF-Interrupt Jump Table

Table Offset	Instruction
0x80	LJMP EP2PF_ISR
0x84	LJMP EP4PF_ISR
0x88	LJMP EP6PF_ISR
0x8C	LJMP EP8PF_ISR
0x90	LJMP EP2EF_ISR
0x94	LJMP EP4EF_ISR
0x98	LJMP EP6EF_ISR
0x9C	LJMP EP8EF_ISR
0xA0	LJMP EP2FF_ISR
0xA4	LJMP EP4FF_ISR
0xA8	LJMP EP6FF_ISR
0xAC	LJMP EP8FF_ISR
0xB0	LJMP GPIFDONE_ISR
0xB4	LJMP GPIFWF_ISR

4.8.1 FIFO/GPIF Autovector Coding

To employ autovectoring for the FIFO/GPIF interrupt, perform the following steps:

1. Insert a jump instruction at 0x0053 to a table of jump instructions to the various FIFO/GPIF interrupt service routines. Make sure the jump table starts at a 0x0100-byte page boundary *plus* 0x80.
2. Code the jump table with jump instructions to each individual FIFO/GPIF interrupt service routine. This table has two important requirements, arising from the format of the INT4VEC byte (0x80-based, with the 2 LSBs set to 0); the two requirements are the following:
 - a. It must begin on a page boundary + 0x80 (address 0xnn80).
 - b. The jump instructions must be four bytes apart.
3. Place the interrupt service routines anywhere in memory.
4. Write initialization code to enable the FIFO/GPIF interrupt (INT4) and Autovectoring.

Figure 4-7 illustrates an ISR that services EP4's Full Flag. When EP4 goes full, the EZ-USB asserts the FIFO/GPIF interrupt request, vectoring to location 0x0053.

The jump instruction at this location, which was originally coded as 'LJMP 0480', becomes 'LJMP 04A4' because the EZ-USB automatically inserts **A4**, the INT4VEC value for EP4FF (Table 4-13 on page 67).

The EZ-USB jumps to 0x04A4, where it executes the jump instruction to the EP4FF ISR, arbitrarily located for this example at address 0x0321.

Once the EZ-USB vectors to 0x0053, initiation of the end-point-specific ISR takes only eight instruction cycles.

Figure 4-7. The FIFO/GPIF Autovector Mechanism in Action

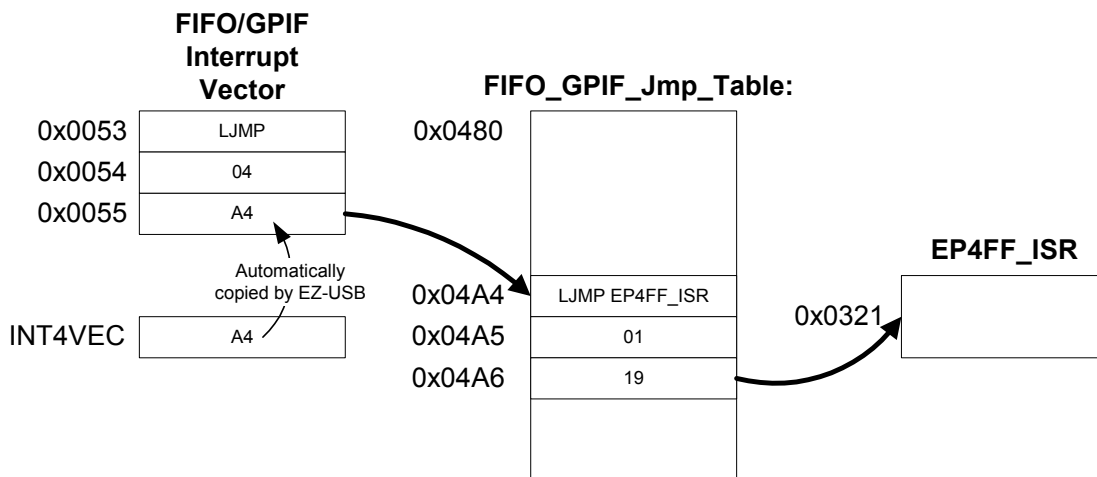

5. Memory



5.1 Introduction

Memory organization in the EZ-USB is similar, but not identical, to that of the standard 8051. There are three distinct memory areas: Internal Data Memory, External Data Memory, and External Program Memory. As is explained below, 'External' memory is not necessarily external to the EZ-USB chip.

5.2 Internal Data RAM

As shown in Figure 5-1, the EZ-USB's Internal Data RAM is divided into three distinct regions: the 'Lower 128', the 'Upper 128', and 'SFR Space'. The Lower 128 and Upper 128 are general purpose RAM; the SFR Space contains EZ-USB control and status registers.

Figure 5-1. Internal Data RAM Organization

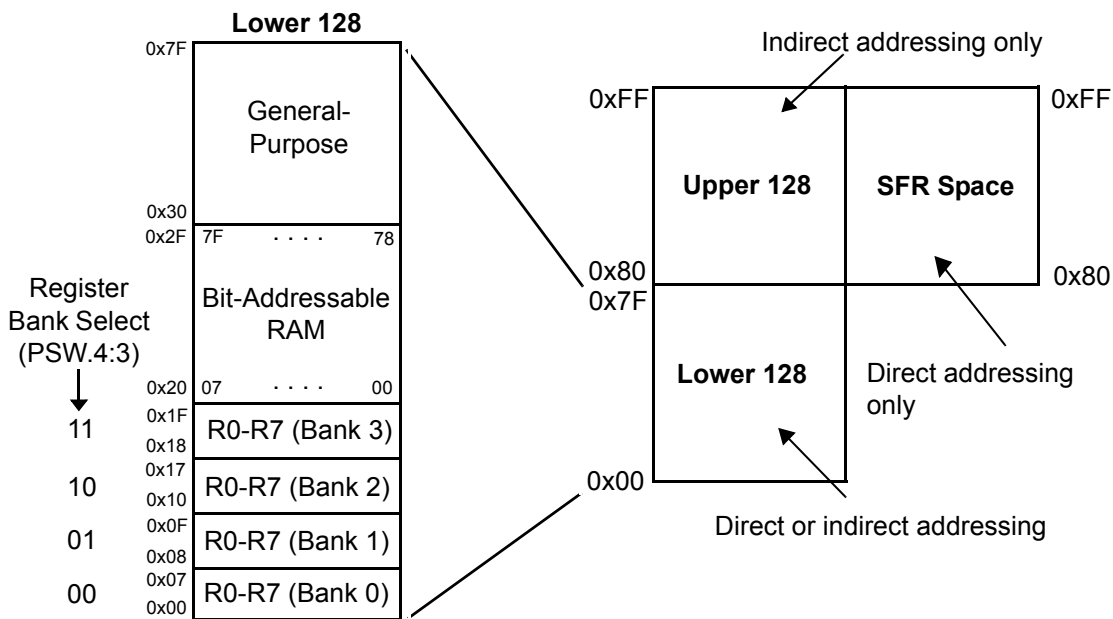

5.2.1 The Lower 128

The Lower 128 occupies Internal Data RAM locations 0x00-0x7F. All of the Lower 128 may be accessed as general-purpose RAM, using either direct or indirect addressing (for more information on the EZ-USB addressing modes. See [chapter "Instruction Set" on page 175](#)).

Two segments of the Lower 128 may be accessed in other ways.

- Locations 0x00-0x1F comprise four banks of 8 registers each, numbered R0 through R7. The current bank is selected via the 'register-select' bits (RS1:RS0) in the PSW special-function register; code which references registers R0-R7 accesses them only in the currently-selected bank.
- Locations 0x20-0x2F are bit addressable. Each of the 128 bits in this segment may be individually addressed, either by its bit address (0x00 to 0x7F) or by reference to the byte which contains it (0x20.0 to 0x2F.7).

5.2.2 The Upper 128

The Upper 128 occupies Internal Data RAM locations 0x80-0xFF; all 128 bytes may be accessed as general-purpose RAM, but only by using indirect addressing (for more information on the EZ-USB addressing modes. See [chapter "Instruction Set" on page 175](#)).

Since the EZ-USB's stack is internally accessed using indirect addressing, it is a good idea to put the stack in the Upper 128; this frees the more-efficiently-accessed Lower 128 for general purpose use.

5.2.3 Special Function Register Space

The Special Function Register (SFR) space, like the Upper 128, is accessed at Internal Data RAM locations 0x80-0xFF. The EZ-USB keeps SFR space separate from the Upper 128 by using different addressing modes to access the two regions: SFRs may only be accessed using 'direct' addressing, and the Upper 128 may only be accessed using 'indirect' addressing.

The SFR space contains EZ-USB control and status registers; an overview is in section [11.12 Special Function Registers on page 174](#), and a full description of all the SFRs is in the [Registers chapter on page 211](#).

The sixteen SFRs at locations 0x80, 0x88, ..., 0xF0, 0xF8 are bit-addressable. Each of the 128 bits in these registers may be individually addressed, either by its bit address (0x80 to 0xFF) or by reference to the byte which contains it (for example, 0x80.0, 0xC8.7, etc.).

5.3 External Program Memory and External Data Memory

The standard 8051 employs a Harvard architecture for its External memory; the program and data memories are physically separate. The EZ-USB uses a modified version of this memory model; 'off-chip' program and data memories are separate, but the 'on-chip' program and data memories are unified in a Von Neumann architecture. This allows the EZ-USB's on-chip RAM to be loaded from an external source (USB or EEPROM, see [Enumeration and ReNumeration™, on page 51](#)), then used as program memory.

Standard 8051

The standard 8051 has separate address spaces for program and data memory; it can address 64 KB of read-only program memory at addresses 0x0000-0xFFFF, and another 64 KB of read/write data memory, also at addresses 0x0000-0xFFFF. The standard 8051 keeps the two memory spaces separate by using different bus signals to access them; the read strobe for program memory is PSEN# (Program Store Enable), and the read and write strobes for data memory are RD# and WR#. The 8051 generates PSEN# strobes for instruction fetches and for the MOVC (move code memory into the accumulator) instruction; it generates RD# and WR# strobes for all data-memory accesses. In a standard 8051 application, an external 64 KB ROM chip (enabled by the 8051's PSEN# signal) might be used for program memory and an external 64 KB RAM chip (enabled by the 8051's RD# and WR# signals) might be used for data memory.

In the standard 8051, all program memory is read only.

EZ-USB

The EZ-USB has 16 KB of on-chip RAM (the 'main RAM') at addresses 0x0000-0x3FFF, and 512 bytes of on-chip RAM (the 'Scratch RAM') at addresses 0xE000-0xE1FF. Although this RAM is physically located inside the chip, it is addressed by EZ-USB firmware as 'External' memory, just as though it were in an external RAM chip.

Some systems use only this on-chip RAM, with no off-chip memory. In those systems, the RD# and PSEN# strobes are automatically combined for accesses to addresses below 0x4000, so the main RAM is accessible as both data and program memory. The RD# and PSEN# strobes are not combined for the Scratch RAM; Scratch RAM is accessible as data memory only.

Although it is technically accurate to say that the main RAM data memory is writable while the main RAM program memory is not, it is a distinction without a difference. The main RAM is accessible both as program memory and data memory, so writing to main RAM data memory is equivalent to writing to main RAM program memory at the same address.

The Scratch RAM is never accessible as program memory.

The EZ-USB also reserves 7.5 KB (0xE200-0xFFFF) of the data-memory address space for control/status registers and endpoint buffers (see section [On-Chip Data Memory at 0xE000-0xFFFF on page 76](#)). **Note** Only the data-memory space is reserved; program memory in the 0xE000-0xFFFF range is not reserved, so the 128-pin EZ-USB can access off-chip program memory in that range.

After a power on reset, the EZ-USB immediately begins executing code at address 0x0000 in the off-chip program memory (as long as there is no EEPROM on the I2C bus with a valid 0xC0 or 0xC2 signature byte), rather than waiting for an EEPROM load or USB code download to complete (see the [Resets chapter on page 83](#) for a full description of the EZ-USB resets).

5.3.1 56- and 100-Pin EZ-USB Chips

The 56- and 100-pin EZ-USB chips have no facility for adding off-chip program or data memory. Therefore, the main RAM must serve as both program and data memory. To accomplish this, the EZ-USB reads the main RAM using the logical OR of the PSEN# and RD# strobes. It is the responsibility of the system designer to ensure that the program- and data-memory spaces do not overlap; with most C compilers, this is done by using linker directives that place the code and data modules into separate areas.

5.3.2 128-Pin EZ-USB Chip

It is possible to add off chip program and data memory to the 128-pin EZ-USB; the organization of that memory depends on the state of the EA (External Access) pin. Note that the EA pin is 'live', meaning it is always active and not just sampled coming out of a chip reset.

EA = 0

The main RAM is accessible both as program and data memory, just as in the 56- and 100-pin EZ-USB.

To avoid conflict with the main RAM, the pins which control access to off-chip memory (the RD#, WR#, CS#, OE#, and PSEN# pins) are inactive whenever the EZ-USB accesses addresses 0x0000-0x3FFF. This allows a 64 KB memory chip (data and/or program) to be added without requiring additional external logic to inhibit access to the lower 16 KB of that chip. Note that the PSEN# and RD# signals are available on separate pins, so the program and data spaces *outside* the EZ-USB are not combined as they are inside the EZ-USB.

When code in the range 0x0000-0x3FFF is fetched from the on-chip RAM, the PSEN# pin is not asserted; when code is fetched from program memory in the range 0x4000-0xFFFF, the PSEN# pin *is* asserted.

EA = 1

All program memory is off chip; all on chip RAM, including the main RAM, is data memory only.

The EZ-USB reads all on-chip RAM using only the RD# strobe; the combining of RD# and PSEN# is disabled, so the on-chip RAM becomes data memory only. All program memory is off-chip; accesses to the lower 16 KB of off-chip program memory are not inhibited.

Any code fetch asserts the PSEN# pin.

5.4 EZ-USB Memory Maps

Figure 5-2. EZ-USB External Program/Data Memory Map, EA=0

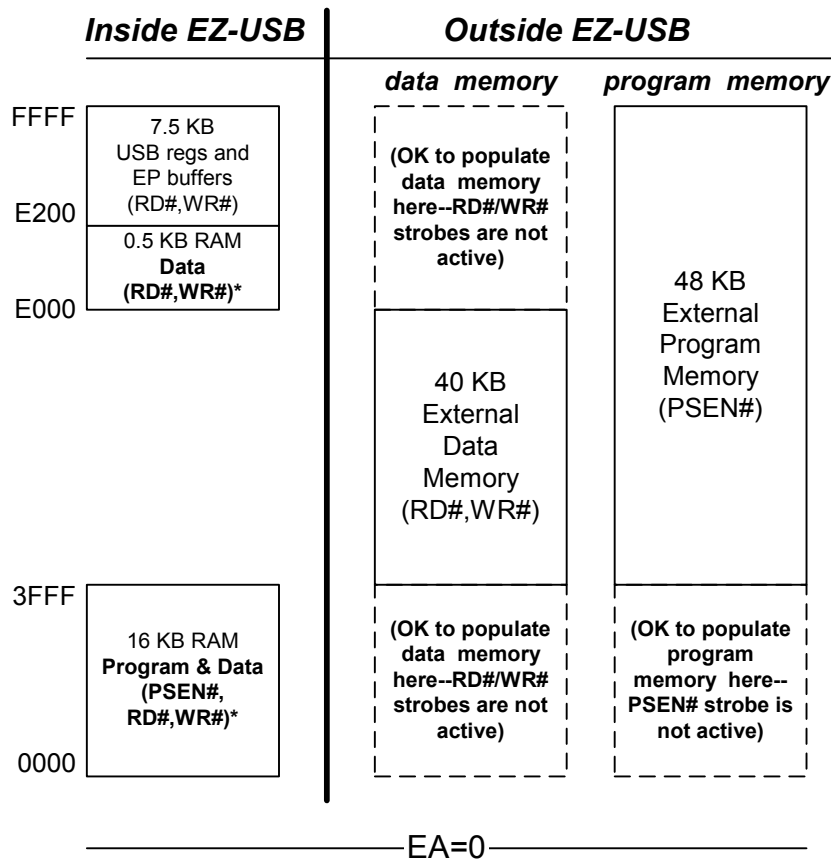

* SUDPTRH:L, USB upload/download, I²C boot access

Figure 5-2 illustrates the memory map of the 128-pin EZ-USB with off-chip program and data memory.

Note The 56- and 100-pin EZ-USB chips cannot access off-chip memory; the entire memory map for those chips is illustrated on the left side of Figure 5-2, in the 'Inside EZ-USB' column.

On-chip EZ-USB memory consists of three RAM regions:

- 0x0000-0x3FFF (main RAM)
- 0xE000-0xE1FF (Scratch RAM)
- 0xE200-0xFFFF (Registers/Buffers)

The 16 KB main RAM occupies program memory (PSEN#) and data memory (RD#/WR#) addresses 0x0000-0x3FFF.

The 512 byte 'Scratch RAM' occupies data memory (RD#/WR#) addresses 0xE000-0xE1FF.

7.5 KB of control/status registers and endpoint buffers occupy data-memory (RD#/WR#) addresses 0xE200-0xFFFF.

When off-chip memory is connected to the EZ-USB, it fills in the gaps not occupied by on-chip EZ-USB RAM. Since the lower 16 KB of memory is occupied by on-chip program/data memory and the upper 8 KB is occupied by on-chip data memory, the off-chip memory cannot be active in these regions. Nevertheless, it is still safe to *populate* those regions with off-chip memory, as the following paragraphs explain.

The middle column of Figure 5-2 indicates EZ-USB data memory (activated by the RD# and WR# strobes) and the right-most column indicates EZ-USB program memory (activated by PSEN#).

The middle 40 KB of the data memory space may be filled with off-chip memory, since it does not conflict with the upper 8 KB of on-chip EZ-USB data memory and the lower 16 KB of on-chip EZ-USB program/data memory. To allow a 64 KB RAM to be connected to the EZ-USB, the EZ-USB gates its RD# and WR# strobes to exclude the top 8 KB and bottom 16 KB for off-chip accesses. Therefore, a 64 KB RAM can be connected to EZ-USB, and the top 8 KB and bottom 16 KB of it are automatically disabled.

Likewise, when a 64 KB program memory (PSEN# strobe) is attached to the EZ-USB (when EA = 0), the lower 16 KB is automatically excluded for off-chip code fetches, avoiding conflict with the on-chip program/data memory inside EZ-USB. This allows the 'upper' 48 KB of program memory space to be filled with off-chip memory.

The asterisks in Figures [Figure 5-2 on page 74](#) and [Figure 5-3](#) indicate memory regions that may be accessed using three special EZ-USB resources:

- Setup Data Pointer (see section [8.7 The Setup Data Pointer on page 95](#))
- Upload or download via USB (see section [3.8 EZ-USB Vendor Request for Firmware Load on page 56](#))
- Code boot from an I2C EEPROM (see section [13.6 EEPROM Boot Loader on page 192](#) and section [3.4 EEPROM Boot-load Data Formats on page 52](#))

[Figure 5-3](#) illustrates the 128-pin EZ-USB memory map when the EA pin is tied high. **Note** The only difference from

[Figure 5-2](#) is that the main RAM is data memory only, instead of combined code/data memory. This allows an off-chip code memory to contain all of the EZ-USB firmware. In this configuration, the EZ-USB can begin executing code from off-chip memory immediately after power-on-reset.

Note EZ-USB code execution begins at address 0x0000, where the reset vector is located.

Off-chip data memory is partially disabled just as in [Figure 5-2 on page 74](#), ensuring that off-chip data memory does not conflict with on-chip data RAM.

Note Be careful to check the access time of external Flash or other program memory in this mode. The EZ-USB can stretch its RD# and WR# strobes to compensate for slow data memories, but it does not have the capability to stretch its PSEN# signal to allow for slow program memories. An external program memory chip must meet the program memory access-time specifications given in the FX2LP and FX1 data sheets.

Figure 5-3. EZ-USB External Program/Data Memory Map, EA=1

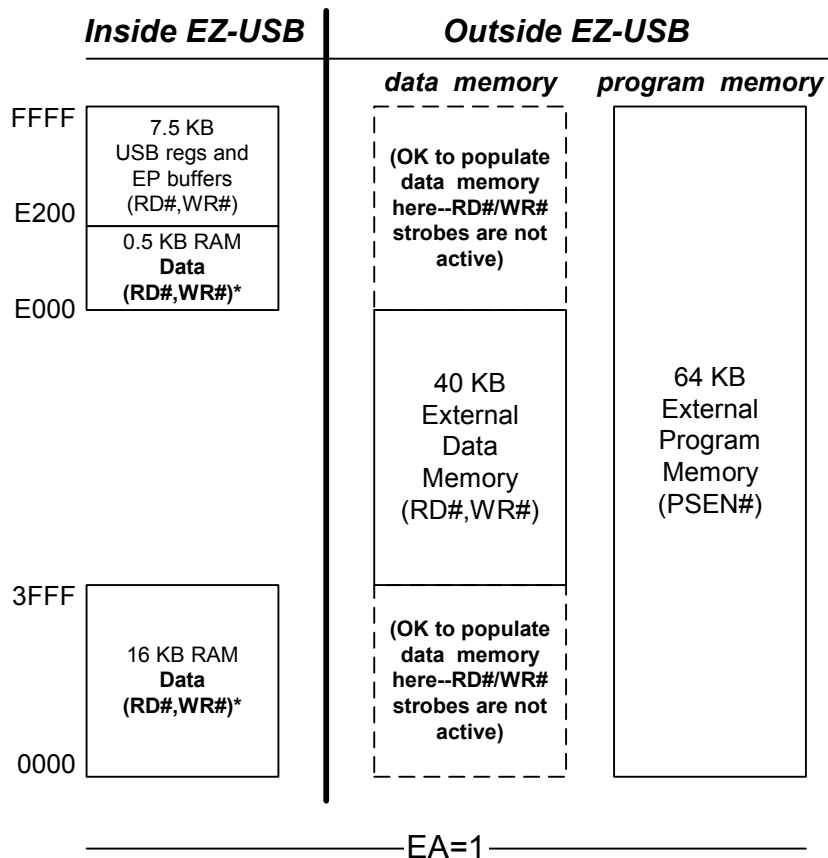

* SUDPTRH:L, USB upload/download, I²C boot access

5.5 ‘Von-Neumannizing’ Off-Chip Program and Data Memory

The 128-pin EZ-USB package provides a 16-bit address bus, an 8 bit data bus, and memory control signals PSEN#, RD#, and WR#. These signals are used to expand the EZ-USB’s external program and/or external data memory.

As described in the previous section, the EZ-USB gates the RD# and WR# signals to exclude selection of off-chip data memory in the range occupied by the on-chip memory. The PSEN# signal is also available on a pin for connection to off-chip code memory.

In some systems, it may be desirable to combine off-chip program and data memory, just as the EZ-USB combines its on-chip program/data main RAM. These systems must logically OR the PSEN# and RD# strobes to qualify the off-chip memory’s chip enable and output enable signals. To save the external logic which would normally be needed, EZ-USB provides two additional control signals, CS# and OE#. The equations for these active-low signals are:

$$CS\# = RD\# + WR\# + PSEN\#$$

$$OE\# = RD\# + PSEN\#$$

Because the RD#, WR#, and PSEN# signals are already qualified by the addresses allocated to off-chip memory, the added strobes CS# and OE# strobes are active only when the EZ-USB accesses off-chip memory.

5.6 On-Chip Data Memory at 0xE000-0xFFFF

Figure 5-4. On-Chip Data Memory at 0xE000-0xFFFF

FFFF	EP2-EP8 (4 KB) Buffers
F000 EFFF	
E800 E7FF E7C0	Reserved (2 KB)
E7BF E780	EP1IN (64)
E77F E740	EP1OUT (64)
E73F E700	EP0 IN/OUT (64)
E6FF	Reserved (64)
E500 E4FF E480	EZ-USB Control and Status Registers (512)
E47F E400	Reserved (128)
E3FF	GPIF Waveforms (128)
E200 E1FF	Reserved (512)
E000	Scratch RAM (512)

Figure 5-4 shows the memory map for on-chip data RAM at 0xE000-0xFFFF.

512 bytes of Scratch RAM are available at 0xE000-0xE1FF. This is data RAM only; code cannot be executed from it. The 128 bytes at 0xE400-0xE47F hold the four waveform descriptors for the GPIF, described in the [General Programmable Interface chapter on page 121](#). The area from 0xE500-0xE6FF contains EZ-USB control and status registers.

Memory blocks 0xE200-0xE3FF, 0xE480-0xE4FF, 0xE700-0xE73F, and 0xE800-0xEFFF) are reserved; they must not be used for data storage.

The remaining RAM contains the endpoint buffers. These buffers are accessible either as addressable data RAM (via the ‘MOVX’ instruction) or as FIFOs (via the Autopointer, described in section [8.8 Autopointers on page 96](#)).

6. Power Management



6.1 Introduction

The USB host can ‘suspend’ a device to put it into a power-down mode. When the USB signals a Suspend operation, the EZ-USB goes through a sequence of steps to allow the firmware first to turn off external power-consuming subsystems, and then to enter a low-power mode by turning off the EZ-USB’s oscillator. Once suspended, the EZ-USB is awakened either by resumption of USB bus activity or by assertion of one of its two WAKEUP pins (provided that they are enabled). This chapter describes the suspend-resume mechanism.

It is important to understand the distinction between ‘suspend’, ‘resume’, ‘idle’, and ‘wakeup’.

- **Suspend** is a request (indicated by a 3-ms ‘J’ state on the USB bus) from the USB host/hub to the device. This request is usually sent by the host when it enters a low power ‘suspended’ state. USB devices are required to enter a low power state in response to this request.

The EZ-USB also provides a register called suspend; writing any value to it allows the EZ-USB to enter the suspended state even when a Suspend condition does not exist on the bus.

- **Resume** is a signal initiated by the device or host driving a ‘K’ state on the USB bus, requesting that the host or device be taken out of its low power ‘suspended’ mode. A USB device can only signal a resume if it has reported (through its Configuration Descriptor) that it is ‘remote wakeup capable’, and only if the host has enabled remote wakeup from that device.
- **Idle** is an EZ-USB low power state. EZ-USB firmware initiates this mode by setting bit zero of the PCON (Power Control) register. To meet the stringent USB suspend current specification, the EZ-USB’s oscillator must be stopped; after the PCON.0 bit is set, the oscillator stops if: a) a suspend condition exists on the bus or the Suspend register has been written to, and b) all three wakeup sources are either disabled or false (WAKEUP, WU2, USB Resume). The EZ-USB exits the Idle state when it receives a wakeup interrupt.
- **Wakeup** is the mechanism which restarts the EZ-USB oscillator and asserts an interrupt to force the EZ-USB to exit the Idle state and resume code execution. The EZ-USB recognizes three wakeup sources: one from the USB itself (when bus activity resumes) and two from device pins (WAKEUP and WU2).

The EZ-USB enters and exits its Idle state independent of USB activity; in other words, the EZ-USB can enter the Idle state at any time, even when not connected to USB. The Idle state is ‘hooked into’ the USB Suspend-Resume mechanism using interrupts. A suspend interrupt is automatically generated when the USB goes inactive for 3 ms; EZ-USB firmware may respond to that interrupt by entering the Idle state to reduce power. If the EZ-USB is in the Idle state, a Wakeup interrupt is generated when one of the three Wakeup sources is asserted; the EZ-USB responds to that interrupt by exiting the Idle state and resuming code execution.

Once the EZ-USB is awake, its firmware may send a USB Resume request by setting the SIGRSUME bit in the USBCS register (at 0xE680). Before sending the Resume request, the device must have: a) reported remote-wakeup capability in its Configuration Descriptor, and b) been given permission (via a ‘Set Feature-Remote Wakeup’ request from the host) to use that remote-wakeup capability. To be compliant with the USB Specification, firmware must wait 5 ms after the Wakeup interrupt, set the SIGRSUME bit, wait 10-15 ms, then clear it.

Figure 6-1 illustrates the EZ-USB logic that implements USB suspend and resume. These operations are explained in the next sections.

Figure 6-1. Suspend-Resume Control

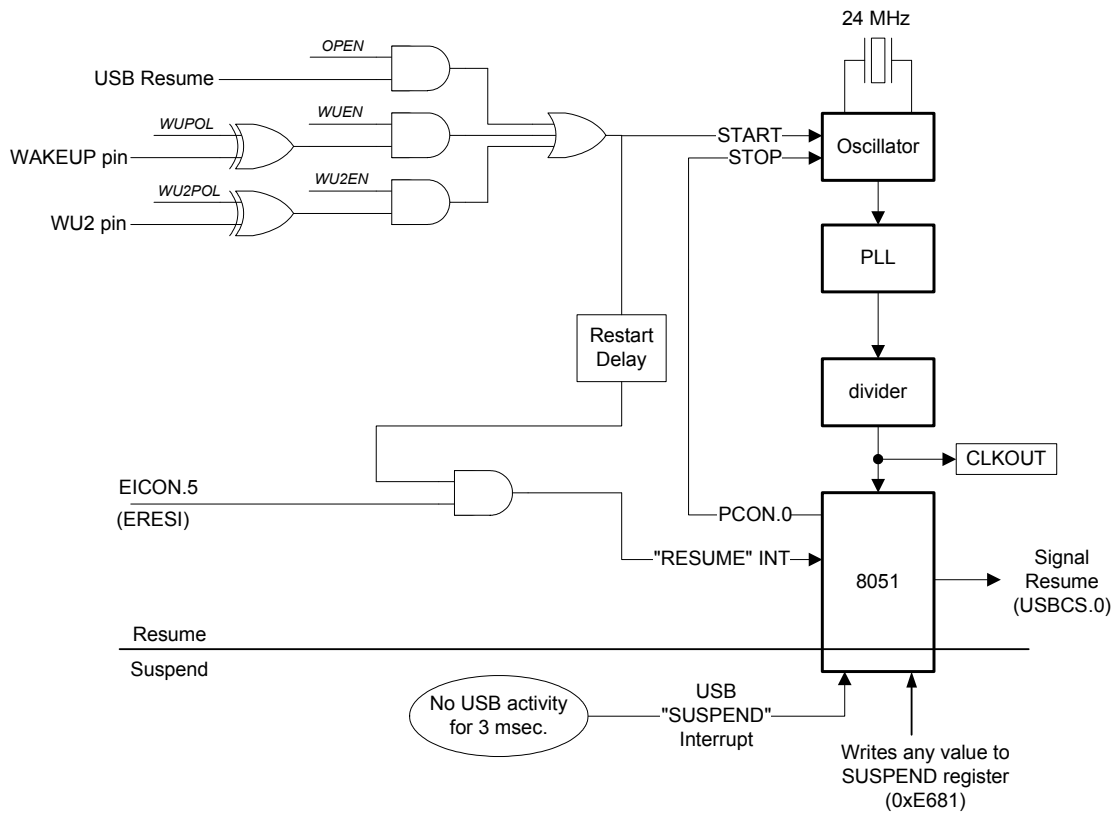

6.2 USB Suspend

Figure 6-2. USB Suspend Sequence

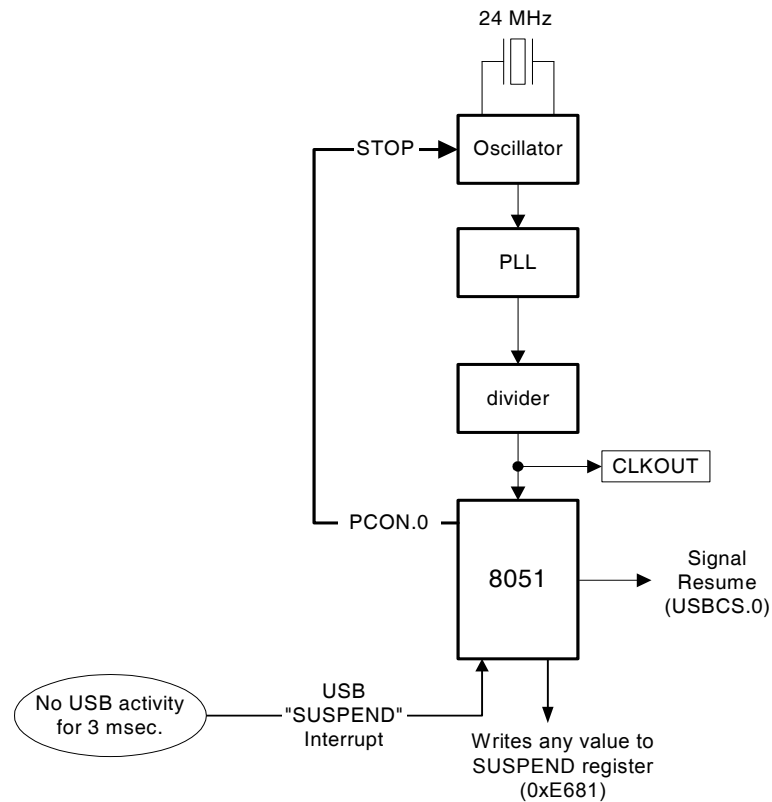

A USB device recognizes a Suspend request as three milliseconds of the bus-idle state. When the EZ-USB detects this condition, it asserts the USB interrupt (INT2) and the Suspend interrupt autovector (vector #3).

If the CPU is in reset when a Suspend condition is detected on the bus, the EZ-USB automatically turns off its oscillators (and keep the CPU in reset) until an enabled Wakeup source is asserted.

Note The bus-idle state is not equivalent to the disconnected-from-USB state; for full-speed, bus-idle is a 'J' state which means that the voltage on D+ is higher than that on D-.

EZ-USB firmware responds to the Suspend interrupt by taking the following actions:

1. Perform any necessary housekeeping such as shutting off external power-consuming devices.
2. Set bit zero of the PCON register.

These actions put the EZ-USB into a low power 'suspend' state, as required by the USB Specification.

6.2.1 Suspend Register

EZ-USB firmware can force the chip into its low-power mode at any time, even without detecting a 3-ms period of inactivity on the USB bus. This 'unconditional suspend' functionality is useful in applications which require the EZ-USB to enter its low-power mode even while disconnected from the USB bus.

To force the EZ-USB unconditionally to enter its low-power mode, firmware simply writes any value to the Suspend register (at 0xE681) before setting the PCON.0 bit.

6.3 Wakeup/Resume

Figure 6-3. EZ-USB Wakeup/Resume Sequence

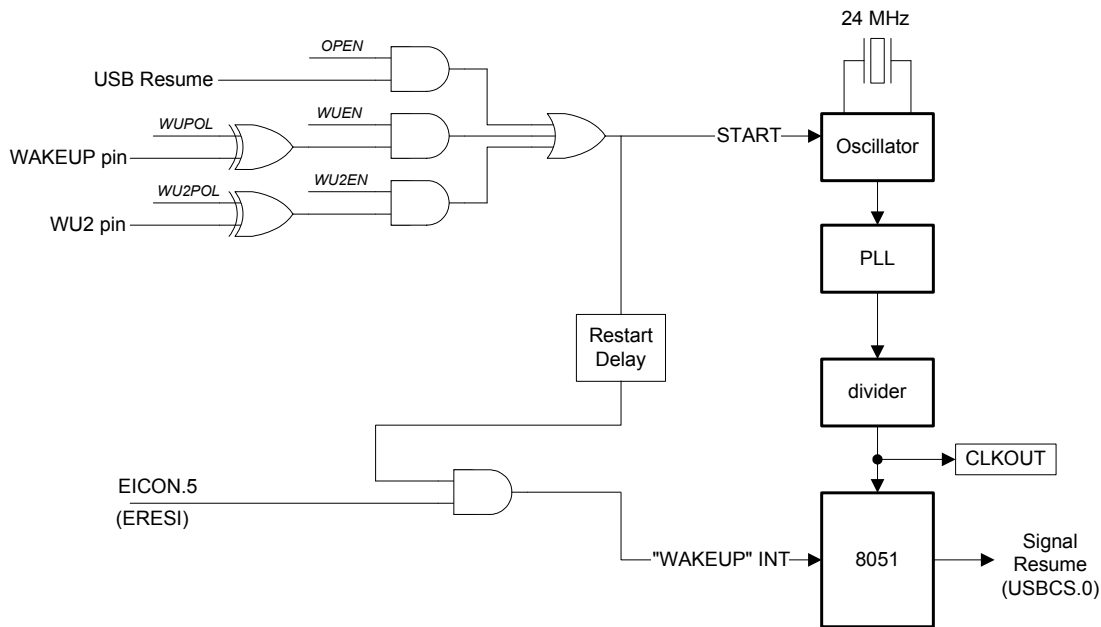

Once in the low-power mode, there are three ways to wake up the EZ-USB:

- USB activity on the EZ-USB's DPLUS pin
- Assertion of the WAKEUP pin
- Assertion of the WU2 ('Wakeup 2') pin

These three Wakeup sources may be individually enabled by setting the DPEN, WUEN, and WU2EN bits in the Wakeup Control register.

WAKEUPCS				Wakeup Control & Status			E682
b7	b6	b5	b4	b3	b2	b1	b0
WU2	WU	WU2POL	WUPOL	0	DPEN	WU2EN	WUEN
R/W	R/W	R/W	R/W	R	R/W	R/W	R/W
0	0	0	0	0	1	0	1

The polarities of the WAKEUP pins are set using the WUPOL and WU2POL bits; '0' is active low and '1' is active high.

Three bits in the Wakeup register enable the three Wakeup sources. DPEN stands for 'DPLUS Enable' (DPLUS is one of the USB data lines; the other is DMINUS).

WUEN (Wakeup Enable) enables the WAKEUP pin, and WU2EN (Wakeup 2 Enable) enables the WU2 pin.

When the EZ-USB chip detects activity on DPLUS while DPEN is true, or a false-to-true transition on WAKEUP or WU2 while WUEN or WU2EN is true, it asserts the Wakeup interrupt.

The status bits WU and WU2 indicate which of the WAKEUP pins caused the Wakeup event. Asserting the WAKEUP pin (according to its programmed polarity) sets the correspond-

ing bit. If the wakeup was caused by resumption of USB DPLUS activity, neither of these bits is set, leading to the conclusion that the third source, a USB bus reset, caused the Wakeup event. EZ-USB firmware clears the WU and WU2 flags by writing '1' to them.

Note Holding either WAKEUP pin in its active state (as determined by the programmed polarity) inhibits the EZ-USB chip from turning off its oscillator in order to enter the 'suspend' state.

Note While disconnected from the USB bus, the DPLUS and DMINUS lines may float. Noise on these lines may indicate activity to the EZ-USB and initiate a Wakeup event. EZ-USB firmware must set DPEN to '0' if this is not desired.

Some designs also use the WAKEUP# pin as a general purpose input pin. Due to the built-in latch on this pin, it must be

cleared before it can show the current state of the pin. For example, to detect a '1' on the WAKEUP# pin use the following code:

```
WAKEUPCS = bmWU | bmWUPOL | bmWUEN; //
Write one to bmWU to clear it, set //
active high, enable //

WAKEUPCS = bmWU | bmWUPOL | bmWUEN; // This
line is required only if WUPOL // is
changing. // A
WUPOL change can trigger a WAKEUP event

if (WAKEUPCS & bmWU)
{
// WAKEUP# is a one
}
else
{
// WAKEUP# is 0
}
```

Note If the polarity is changed, an additional Wakeup event may be triggered. Always clear the Wakeup event after changing the polarity.

6.3.1 Wakeup Interrupt

When a Wakeup event occurs, the EZ-USB restarts its oscillator and, after the PLL stabilizes, it generates an interrupt request. This applies whether or not the EZ-USB is connected to the USB. The Wakeup interrupt is a dedicated interrupt, and is not shared by USBINT like most of the other individual USB interrupts.

The Wakeup interrupt vector is at 0x33, and has the highest interrupt priority. It is enabled by ERESI (EICON.5), and its IRQ flag is at EICON.4 (EICON is SFR 0xD8). **Note** If the EZ-USB is suspended with ERESI (EICON.5) low, it never 'wakes up'.

The Wakeup interrupt Service Routine clears the interrupt request flag RESI (using the 'bit clear' instruction, i.e. 'clr EICON.4'), and then executes a 'RETI' (return from interrupt) instruction. This causes the EZ-USB to continue program execution at the instruction following the one that set PCON.0 to initiate the power-down operation.

About the Wakeup Interrupt

The EZ-USB enters its idle state when it sets PCON.0 to '1'. Although a standard 8051 exits the idle state when any interrupt occurs, the EZ-USB supports only the Wakeup interrupt to exit the idle state.

Note If PCON.0 is set when no Suspend condition exists (for example, the USB is not signaling 'Suspend', and firmware has not written to the Suspend register), the Wakeup interrupt fires immediately.

6.4 USB Resume (Remote Wakeup)

USBSCS		USB Control and Status						E680
b7	b6	b5	b4	b3	b2	b1	b0	
HSM	-	-	-	DISCON	NOSYNSOF	RENUM	SIGRSUME	

Firmware sets the SIGRSUME bit to send a remote-wakeup request to the host. To be compliant with the USB Specification, the firmware must wait 5 milliseconds after the Wakeup interrupt, set the SIGRSUME bit, wait 10-15 milliseconds, then clear it.

Note Before setting the SIGRSUME bit to '1', EZ-USB firmware must check that the source of the Wakeup event was one of the WAKEUP pins. If neither WAKEUP pin was the source, the Wakeup event was the resumption of USB DPLUS activity, and in this case, the device must not signal a remote-wakeup by setting the SIGRSUME bit to '1'.

The Default USB Device does not support remote wakeup. This fact is reported at enumeration time in byte 7 of the built-in Configuration Descriptor (see Appendices A and B).

6.4.1 WU2 Pin

The WU2 function shares the general-purpose I/O pin PA3. Unlike other multi-purpose I/O pins that use configuration registers (PORTACFG, PORTCCFG, and PORTECFG) to select alternate functions, the PA3 and WU2 functions are simultaneously active. However, the WU2 function has no effect unless enabled (by setting the WU2EN bit to '1'). If WU2 is used as a WAKEUP pin, make sure to set PA3 as an input (OEA.3=0, the default state) to prevent PA3 from also driving the pin.

The dual nature of the PA3/WU2 pin allows the EZ-USB to enter the low-power mode, then periodically awaken itself. This is done by connecting an RC network to the PA3/WU2 pin; if the WU2 pin is set to the default polarity (active-high),

Power Management

the resistor is connected to 3.3V and the capacitor is connected to ground.

The firmware then performs these steps:

1. Set W2POL to '1' for active-high polarity on the WU2 pin.
2. Set WU2EN to '1' to enable Wakeup 2.
3. Enable the Wakeup interrupt by setting EICON.5=1.
4. Set PA3 to '0', then set OEA.3 to '1'. This enables the PA3 output and drives the PA3/WU2 pin to ground, discharging the capacitor.
5. Set OEA.3 to '0'. This floats the PA3/WU2 pin, allowing the resistor to begin charging the capacitor.
6. Write any value to the Suspend register, so the EZ-USB unconditionally stops the oscillator when the firmware sets PCON.0.
7. Set PCON.0 to '1'. This commands the EZ-USB to enter the Idle state.

After the capacitor charges to a logic high level, the Wakeup interrupt triggers via the WU2 pin.

1. In the Wakeup interrupt service routine, clear EICON.4 (the Wakeup interrupt request flag), then execute a 'RETI' instruction. This resumes program execution at the instruction following the instruction in step 7.
2. At this point, the firmware can check for any tasks to perform; if none are required, it can then re-enter the Idle state starting at step 4.

By selecting a long time constant for the RC network attached to the WU2 pin, the EZ-USB chip can operate at extremely low average power, since the on/off (active/suspend) duty-cycle is very short.

7. Resets



7.1 Introduction

There are three different reset functions on the EZ-USB. This chapter describes their effects.

- **Hard Reset.** An active low reset pin (RESET#) is provided in order to reset the EZ-USB to a known state at power-on or any other application-specific reset event.
- **CPU Reset.** This is controlled by the EZ-USB's USB Core logic. The CPU Reset is always asserted (for example, the CPU is always held in reset) while the EZ-USB's RESET# pin is asserted.
- **USB Bus Reset.** This is a condition on the USB bus initiated by the USB host in order to put every device's USB functions in a known state.

Figure 7-1. EZ-USB Resets

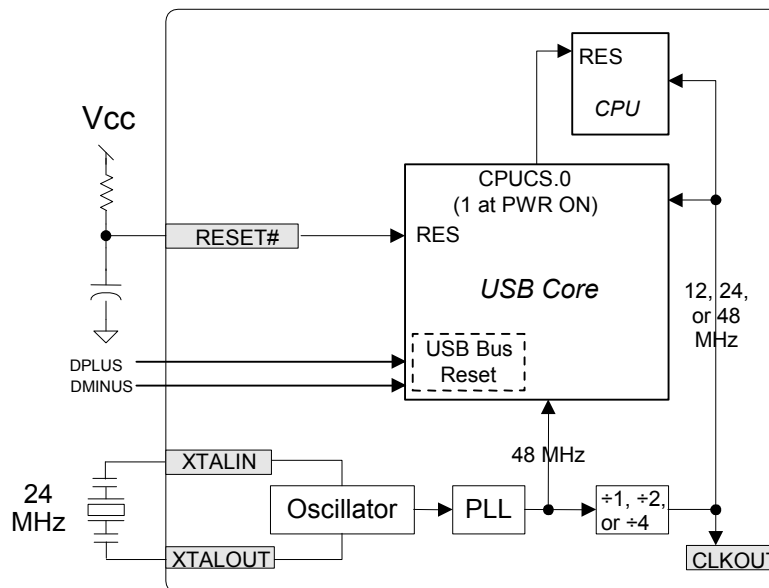

7.2 Hard Reset

The RESET# pin can be connected to an external R-C network or other external reset source in order to ensure that, when power is first applied, the EZ-USB is held in reset until the operating parameters (VCC voltage, crystal frequency, PLL frequency, and others) stabilize. The 24 MHz oscillator and PLL stabilize 5 ms after VCC reaches 3.0V. An R-C network can satisfy the power-on reset requirements of the EZ-USB. See Figure 7-1 for a sample connection scheme (for example, R = 27K ohm, C = 1 μ F).

The RESET# pin can also be asserted at any time after the EZ-USB is running. If the EZ-USB's XTALIN pin is driven by an external clock source that continues to run while the chip is in reset, RESET# need only be asserted for 200 μ s. Otherwise, it must be asserted for at least 5 ms.

The CLKOUT pin, crystal oscillator, and PLL are active as soon as power is applied. Once the CPU is out of reset, firmware may clear a control bit (CLKOE, CPUCS.1) to inhibit the CLKOUT output pin for EMI-sensitive applications that do not need this signal.

The CLKOUT signal is active while RESET# is low. When RESET# returns high, the activity on the CLKOUT pin depends on whether or not the EZ-USB is in the low-power 'suspend' state; if it is, CLKOUT stops. Resumption of USB bus activity or assertion of the WAKEUP or WU2 pin (if enabled) restarts the CLKOUT signal.

Power-on default values for all EZ-USB register bits are shown in the [Registers chapter on page 211](#). At power-on reset:

- Endpoint data buffers and byte counts are uninitialized
- The CPU clock speed is set to 12 MHz, the CPU is held in reset, and the CLKOUT pin is active
- All port pins are configured as general purpose input pins
- USB interrupts are disabled and USB interrupt requests are cleared
- Bulk IN and OUT endpoints are unarmed, and their stall bits are cleared. The EZ-USB NAKs IN and OUT tokens while the CPU is reset.
- Endpoint data toggle bits are cleared to '0'
- The RENUM bit is cleared to '0'. This means that the Default USB Device, not the firmware, responds to USB device requests.
- The USB Function Address register is cleared to '0'
- The endpoints are configured for the Default USB Device
- Interrupt autovectoring is turned Off
- Configuration Zero, Alternate Setting Zero is in effect
- The D+ pull up resistor is disconnected from the data line during a hard reset

7.3 Releasing the CPU Reset

Register bit CPUCS.0 resets the CPU. This bit is set to '1' at power-on, initially holding the CPU in reset. There are three ways that the CPUCS.0 bit can be cleared to '0', releasing the CPU from reset:

- By the host, as the final step of a RAM download
- Automatically, at the end of an EEPROM load (assuming the EEPROM is correctly programmed)
- Automatically, when external ROM is used (EA=1) and no 'C0' or 'C2' EEPROM is present

Note EZ-USB firmware cannot put the CPU into reset by setting CPUCS.0 to '1'; to the firmware, that bit is read only.

7.3.1 RAM Download

Once enumerated, the host can download code into the EZ-USB RAM using the 'Firmware Load' vendor request ([Endpoint Zero chapter on page 37](#)). The last packet loaded writes 0x00 to the CPUCS register, which releases the CPU from reset. Note that only CPUCS.0 can be written in this way.

7.3.2 EEPROM Load

The [Enumeration and ReEnumeration™ chapter on page 51](#) describes the EEPROM boot loads in detail. At power-on, the EZ-USB checks for the presence of an EEPROM on its I2C bus. If found, it reads the first EEPROM byte. If it reads 0xC2 as the first byte, the EZ-USB downloads firmware from the EEPROM into internal RAM. The last operation in a 'C2' Load writes 0x00 to the CPUCS register, which releases the CPU from reset.

After a 'C2' Load, the EZ-USB sets the RENUM bit to '1', so the firmware is responsible for responding to USB device requests.

7.3.3 External ROM

The 128-pin EZ-USB can use off-chip program memory containing EZ-USB code and USB device descriptors, which include the VID/DID/PID bytes. Because such a system does not require an I2C EEPROM to supply the VID/DID/PID, the EZ-USB automatically releases the CPU from reset when:

- The EA pin is pulled high (indicating off-chip code memory), *and*
- No 'C0/C2' EEPROM is detected on the I2C bus

Under these conditions, the EZ-USB also sets the RENUM bit to '1', so the firmware is responsible for responding to USB device requests.

7.4 CPU Reset Effects

The USB host may reset the CPU at any time by downloading the value 0x01 to the CPUCS register. The host might do this, for example, in preparation for loading code overlays, effectively magnifying the size of the internal EZ-USB RAM. For such applications, it is important to know the state of the EZ-USB chip during and after a CPU reset. In this section, this particular reset is called a 'CPU Reset,' and should not be confused with the resets described in [section 7.2 Hard Reset on page 83](#). This discussion applies only to the condition in which the EZ-USB chip is powered, and the CPU is reset by the host setting the CPUCS.0 bit to '1'.

The basic USB device configuration remains intact through a CPU reset. Endpoints keep their configuration, the USB Function Address remains the same, and the I/O ports retain their configurations and values. Stalled endpoints remain

stalled, data toggles do not change, and the RENUM bit is unaffected. The only effects of a CPU reset are as follows:

- USB (INT2) interrupts are disabled, but pending interrupt requests remain pending.
- When the CPU comes out of reset, pending interrupts are kept pending, but disabled. This gives the firmware writer the choice of acting on pre-reset USB events, or ignoring them by clearing the pending interrupts before enabling INT2.
- The breakpoint condition (BREAKPT.3) is cleared.
- While the CPU is in reset, the EZ-USB enters the Suspend state automatically if a 'suspend' condition is detected on the bus.

7.5 USB Bus Reset

The host signals a USB bus reset by driving an SE0 state (both D+ and D- data lines low) for a minimum of 10 ms. The EZ-USB senses this condition, requests the USB Interrupt (INT2), and supplies the interrupt vector for a USB Reset. After a USB bus reset, the following occurs:

- Data toggle bits are cleared to '0'.
- The device address is reset to '0'.
- If the Default USB Device is active, the USB configuration and alternate settings are reset to '0'.
- The FX2LP renegotiates with the host for high-speed (480 Mbps) mode.

Note that the RENUM bit is unchanged after a USB bus reset. Therefore, if a device has ReNumerated™ and loaded a new personality, it retains the new personality through a USB bus reset.

7.6 EZ-USB Disconnect

Although not strictly a 'reset,' the disconnect-reconnect sequence used for ReNumeration™ affects the EZ-USB in ways similar to the other resets. When the EZ-USB simulates a disconnect-reconnect, the following occurs:

- Endpoint STALL bits are cleared.
- Data toggles are reset to '0'.
- The Function Address is reset to '0'.
- If the Default USB Device is active, the USB configuration and alternate settings are reset to '0'.

7.7 Reset Summary

Table 7-1. Effects of Various Resets on EZ-USB Resources (“—” means “no change”)

	RESET# Pin	CPU Reset	USB Bus Reset	Disconnect
CPU Reset	Reset	n/a	—	—
IN Endpoints	Unarm	—	—	—
OUT Endpoints	Unarm	—	—	—
Breakpoint	0	0	—	—
Stall Bits	0	—	—	0
Interrupt Enables	0	0	—	—
Interrupt Requests	0	—	—	—
CLKOUT	Active	—	—	—
CPU Clock Speed	12 MHz	—	—	—
Data Toggles	0	—	0	0
Function Address	0	—	0	0
Default USB Device Configuration	0	—	0	0
Default USB Device Alternate Setting	0	—	0	0
RENUM Bit	0	—	—	—

Resets

8. Access to Endpoint Buffers



8.1 Introduction

USB data enters and exits the EZ-USB via endpoint buffers. **Note** External logic usually reads and writes this data by direct connection to the endpoint FIFOs without any participation by the EZ-USB's CPU. This is especially necessary for the FX2LP, which can operate at the high-speed 480 Mbits/sec transfer rate. However, this feature is also available for FX2LP when attached to a full-speed host and for the full-speed-only FX1.

Note The chapters [Slave FIFOs, on page 99](#) and [General Programmable Interface, on page 121](#) give details about how external logic directly connects to the large endpoint FIFOs. Direct connection is available only on endpoints 2, 4, 6, and 8.

In the following sections, references to full-speed behavior refer to both FX2LP attached to a full-speed host and to the full-speed-only FX1.

When an application requires the CPU to process the data as it flows between external logic and the USB — or when there is no external logic — firmware can access the endpoint buffers either as blocks of RAM or (using a special auto-incrementing pointer) as a FIFO.

Even when external logic or the built-in General Programmable Interface (GPIF) is handling high-bandwidth data transfers through the four large endpoint FIFOs without any CPU intervention, the firmware has certain responsibilities:

- Configure the endpoints
- Respond to host requests on CONTROL endpoint zero
- Control and monitor GPIF activity
- Handle all application-specific tasks using its USARTs, counter-timers, interrupts, I/O pins, and so on

8.2 EZ-USB Large and Small Endpoints

EZ-USB endpoint buffers are divided into 'small' and 'large' groups. EP0 and EP1 are small, 64-byte endpoints which are accessible only by the CPU; they cannot be connected directly to external logic.

EP2, EP4, EP6 and EP8 are large, configurable endpoints designed to meet the high-bandwidth requirements of USB 2.0. Although data normally flows through the large endpoint buffers under control of the FIFO interfaces described in Chapters 9 and 10, the CPU can access the large endpoints if necessary.

8.3 High Speed and Full Speed Differences

The data payload size and transfer speed requirements differ between full speed (12 Mbps) and high speed (480 Mbps). The EZ-USB architecture is optimized for high-speed transfers, but does not limit full-speed transfers:

- Instead of many small endpoint buffers, EZ-USB provides a reduced number of large buffers
- EZ-USB provides double, triple, or quad buffering on its large endpoints (EP2, 4, 6, and 8)
- The CPU need not participate in data transfers. Instead, dedicated EZ-USB logic and unified endpoint/interface FIFOs move data on and off the chip without any CPU intervention.

In the FX2LP, endpoint buffers appear to have different sizes depending on whether it is operating at full or high speed. This is due to the difference in maximum data payload sizes allowed by the USB specification for the two modes, as illustrated by [Table 8-1](#). FX1 always operates in full-speed mode.

Table 8-1. Maximum Data Payload Sizes for Full Speed and High Speed

Transfer Type	Max Data Payload Size	
	Full Speed	High Speed
CONTROL (EP0 only)	8,16,32,64	64
BULK	8,16,32,64	512
INTERRUPT	1-64	1-1024
ISOCRONOUS	1-1023	1-1024

Although the EP2, EP4, EP6, and EP8 buffers are physically large, they appear as smaller buffers for the non-isochronous types when the EZ-USB is operating at full speed. This is to account for the smaller maximum data payload sizes.

When operating at high speed, firmware can configure the large endpoints' size, type, and buffering depth; when operating at full speed, type and buffering are configurable but the buffer size is always fixed at 64 bytes for the non-isochronous types.

8.4 How the CPU Configures the Endpoints

Endpoints are configured using the six registers shown in [Table 8-2](#).

Table 8-2. Endpoint Configuration Registers

Address	Name	Configurable Parameters
0xE610	EP1OUTCFG	valid, type ¹ (always OUT, 64 bytes, single-buffered)
0xE611	EP1INCFG	valid, type ¹ (always IN, 64 bytes, single-buffered)
0xE612	EP2CFG	valid, direction, type, size, buffering
0xE613	EP4CFG	valid, direction, type (always 512 bytes, double-buffered in high-speed mode, 64 bytes double-buffered in full-speed mode for non-iso)
0xE614	EP6CFG	valid, direction, type, size, buffering
0xE615	EP8CFG	valid, direction, type (always 512 bytes double-buffered in high-speed mode, 64 bytes double-buffered in full-speed mode for non-iso)

Note 1: For EP1, 'type' may be set to Interrupt or Bulk only. Even though these buffers are 64 bytes in size, they are reported as 512 for USB 2.0 compliance. The user must never transfer packets larger than 64 bytes to EP1.

Note The [Registers chapter on page 211](#) gives full bit-level details for all endpoint configuration registers.

Endpoint 0 does not require a configuration register since it is fixed as valid, IN/OUT, CONTROL, 64 bytes, single-buffered. EP0 uses a single 64-byte buffer both for IN and OUT transfers. EP1 uses separate 64 byte buffers for IN and OUT transfers.

Endpoints EP2 and EP6 are the most flexible endpoints, as they are configurable for size (512 or 1024 bytes in high-speed mode, 64 bytes in full-speed mode for the non-isochronous types) and depth of buffering (double, triple, or quad). Endpoints EP4 and EP8 are fixed at 512 bytes, double-buffered in high-speed mode. They are fixed at 64 bytes, double-buffered in full-speed mode for the non-isochronous types.

The bits in the EPxCFG registers control the following:

- Valid. Set to '1' (default) to enable the endpoint. A non-valid endpoint does not respond to host IN or OUT packets.
- Type. Two bits, TYPE1:0 (bits 5 and 4) set the endpoint type.
 - 00 = *invalid*
 - 01 = ISOCRONOUS (EP2,4,6,8 only)
 - 10 = BULK (default)
 - 11 = INTERRUPT
- Direction. 1 = IN, 0 = OUT.
- Buffering. EP2 and EP6 only. Two bits, BUF1:0 control the depth of buffering.
 - 00 = quad
 - 01 = *invalid*
 - 10 = double (default)
 - 11 = triple

'Buffering' refers to the number of RAM blocks available to the endpoint. With double buffering, for example, USB data can fill or empty an endpoint buffer at the same time that another packet from the same endpoint fills or empties from the external logic. This technique maximizes performance by saving each side, USB and external-logic interface, from waiting for the other side. Multiple buffering is most effective when the providing and consuming rates are comparable but bursty (as is the case with USB and many other interfaces, such as disk drives). Assigning more RAM blocks (triple and quad buffering) provides more 'smoothing' of the bursty data rates. A simple way to determine the appropriate buffering depth is to start with the minimum, then increase it until no NAKs appear on the USB side and no wait states appear on the interface side.

Note The Valid bit is ignored when buffer space is allocated by the EZ-USB (for example, BUF[1:0] takes precedence over the Valid bit).

When you are not using all of the endpoints in the endpoint configuration, disable the unused endpoints by writing a zero into the "valid" bit of the corresponding EPxCFG register without disturbing the default state of the other bits in the register.

For example, if the endpoint configuration 11 (see [1.17 EZ-USB Endpoint Buffers on page 30](#)), which utilizes only endpoints 2 and 8, must be used, configure the endpoints as follows.

```
EP2CFG = 0xDB;
```

```
SYNCDELAY;
```

```
EP8CFG = 0x92;
```

```
SYNCDELAY;
```

```
EP4CFG &= 0x7F;
```

```
SYNCDELAY;
```

```
EP6CFG &= 0x7F;
```

```
SYNCDELAY;
```

8.5 CPU Access to EZ-USB Endpoint Data

Endpoint data is visible to the CPU at the addresses shown in [Table 8-3](#). Whenever the application calls for endpoint buffers smaller than the physical buffer sizes shown in [Table 8-3](#), the CPU accesses the endpoint data starting from the lowest address in the buffer. For example, if EP2 has a reported MaxPacketSize of 512 bytes, the CPU accesses the data in the lower portion of the EP2 buffer (that is, from 0xF000 to 0xF1FF). Similarly, if the EZ-USB is operating in full-speed mode (which dictates a maximum bulk packet size of only 64 bytes), only the lower 64 bytes of the end-

point (for example, 0xF000-0xF03F for EP2) are used for bulk data.

Table 8-3. Endpoint Buffers in RAM Space

Name	Address	Size (bytes)
EPOBUF	0xE740-0xE77F	64
EP1OUTBUF	0xE780-0xE7BF	64
EP1INBUF	0xE7C0-0xE7FF	64
EP2FIFOBUF	0xF000-0xF3FF	1024
EP4FIFOBUF	0xF400-0xF7FF	1024
EP6FIFOBUF	0xF800-0xFBFF	1024
EP8FIFOBUF	0xFC00-0xFFFF	1024

Note EPOBUF is for the (optional) data stage of a Control transfer. The eight bytes of data from the Control packet appear in a separate EZ-USB RAM buffer called SETUP-DAT, at 0xE6B8-0xE6BF.

The CPU can only access the 'active' buffer of a multiple-buffered endpoint. In other words, firmware must treat a quad-buffered 512-byte endpoint as being only 512 bytes wide, even though the quad-buffered endpoint actually occupies 2048 bytes of RAM. Also, when EP2 and EP6 are configured such that EP4 and/or EP8 are unavailable, the firmware must never attempt to access the buffers corresponding to those unavailable endpoints.

For example, if EP2 is configured for triple-buffered 1024-byte operation, the firmware should access EP2 only at 0xF000-0xF3FF. The firmware should not access the EP4 or EP6 buffers in this configuration, since they do not exist (the RAM space which they would normally occupy is used to implement the EP2 triple-buffering).

8.6 CPU Control of EZ-USB Endpoints

From the CPU's point of view, the 'small' and 'large' endpoints operate slightly differently, due to the multiple-packet buffering scheme used by the large endpoints.

The CPU uses internal registers to control the flow of endpoint data. Since the small endpoints EP0 and EP1 are programmed differently than the large endpoints EP2, EP4, EP6, and EP8, these registers fall into three categories:

- Registers that apply to the small endpoints (EP0, EP1IN, and EP1OUT)
- Registers that apply to the large endpoints (EP2, EP4, EP6, and EP8)
- Registers that apply to both sets of endpoints

8.6.1 Registers That Control EP0, EP1IN, and EP1OUT

Table 8-4. Registers that control EP0 and EP1

Address	Name	Function
0xE6A0	EP0CS	EP0 HSNACK, Busy, Stall
0xE68A	EP0BCH	EP0 Byte Count (MSB)
0xE68B	EP0BCL	EP0 Byte Count (LSB)
0xE65C	USBIE	EP0 Interrupt Enables
0xE65D	USBIRQ	EP0 Interrupt Requests
SFR 0xBA	EP01STAT	Endpoint 0 and 1 Status
0xE6A1	EP1OUTCS	EP1OUT Busy, Stall
0xE68D	EP1OUTBC	EP1OUT Byte Count
0xE6A2	EP1INCS	EP1IN Busy, Stall
0xE68F	EP1INBC	EP1IN Byte Count

8.6.1.1 EP0CS

Firmware uses this register to coordinate Control transfers over endpoint 0. The EP0CS register contains three bits: HSNACK, Busy and Stall.

HSNACK

HSNACK is automatically set to '1' whenever the SETUP token of a Control transfer arrives. The EZ-USB logic automatically NAKs the status (handshake) stage of the Control transfer until the firmware clears the HSNACK bit by writing '1' to it. This mechanism gives the firmware a chance to hold off subsequent transfers until it completes the actions required by the Control transfer.

Note Firmware must clear the HSNACK bit after servicing every Control transfer.

BUSY

The read-only Busy bit is relevant only for the data stage of a Control transfer. BUSY=1 indicates that the endpoint is currently being serviced by USB, so firmware should not access the endpoint data.

'Busy' is automatically cleared to '0' whenever the SETUP token of a Control transfer arrives. The Busy bit is set to '1' under different conditions for IN and OUT transfers.

For EP0 IN transfers, EZ-USB logic will NAK all IN tokens to EP0 until the firmware has 'armed' EP0 for IN transfers by writing to the EP0BCH:L Byte Count register, which sets BUSY=1 to indicate that firmware should not access the data. Once the endpoint data is sent and acknowledged, Busy is automatically cleared to '0' and the EP0IN interrupt request bit is asserted. After Busy is automatically cleared to '0', the firmware may refill the EP0IN buffer.

For EP0 OUT transfers, EZ-USB logic will NAK all OUT tokens to EP0 until the firmware has 'armed' EP0 for OUT transfers by writing any value to the EP0BCL register. Busy

is automatically set to '1' when the firmware writes to EP0BCL, and Busy is automatically cleared to '0' after the data has been correctly received and ACK'd. When Busy transitions to zero, the EZ-USB also generates an EP0OUT interrupt request.

Note The EZ-USB's autovectored interrupt system automatically transfers control to the appropriate Interrupt Service Routine (ISR) for the endpoint requiring service. The [Interrupts chapter on page 59](#) describes this mechanism.

STALL

Set STALL=1 to instruct the EZ-USB to return the Stall response to a Control transfer. This is generally done when the firmware does not recognize an incoming USB request. According to the USB specification, endpoint zero must always accept transfers, so Stall is automatically cleared to '0' whenever a SETUP token arrives. If it is desired to stall a transfer and also clear HSNACK to '0' (by writing a '1' to it), the firmware should set STALL=1 first, in order to ensure that the Stall bit is set before the 'acknowledge' phase of the Control transfer can complete.

8.6.1.2 EP0BCH and EP0BCL

These are the byte count registers for bytes sent as the optional data stage of a Control transfer. Although the EP0 buffer is only 64 bytes wide, the byte count registers are 16 bits wide to allow using the Setup Data Pointer to send USB IN data records that consist of multiple packets.

To use the Setup Data Pointer in its most-general mode, firmware clears the SUDPTR AUTO bit and writes the word-aligned address of a data block into the Setup Data Pointer, then loads the EP0BCH:L registers with the total number of bytes to transfer. The EZ-USB automatically transfers the entire block, partitioning the data into MaxPacketSize packets as necessary.

Note The Setup Data Pointer is the subject of section [8.7 The Setup Data Pointer on page 95](#).

For IN transfers without using the Setup Data Pointer, firmware loads data into EP0BUF, then writes the number of bytes to transfer into EP0BCH and EP0BCL. The packet is armed for IN transfer when the firmware writes to EP0BCL, so EP0BCH should always be loaded first. These transfers are always 64 bytes or less, so EP0BCH must be loaded with '0' (and EP0BCL must be in the range [0-64]). EP0BCH holds that zero value until firmware overwrites it.

For EP0 OUT transfers, the byte count registers indicate the number of bytes received in EP0BUF. Byte counts for EP0 OUT transfers are always 64 or fewer, so EP0BCH is always zero after an OUT transfer. To re-arm the EP0 buffer for a future OUT transfer, the firmware simply writes any value to EP0BCL.

Note The EP0BCH register must be initialized on reset, since its power-on-reset state is undefined.

8.6.1.3 USBIE, USBIRQ

Three interrupts — SUTOK, SUDAV, and EP0ACK — are used to manage Control transfers over endpoint zero. The individual enables for these three interrupt sources are in the USBIE register, and the interrupt-request flags are in the USBIRQ register.

Each of the three interrupts signals the completion of a different stage of a Control transfer.

- SUTOK. (Setup Token) asserts when EZ-USB receives the SETUP token.
- SUDAV. (Setup Data Available) asserts when EZ-USB logic has loaded the eight bytes from the SETUP stage into the 8-byte buffer at SETUPDAT.
- EP0ACK. (Endpoint Zero Acknowledge) asserts when the handshake stage has completed.

The SUTOK interrupt is not normally used; it is provided for debug and diagnostic purposes. Firmware generally services the Control transfer by responding to the SUDAV interrupt, since this interrupt fires only after the eight setup bytes are available for examination in the SETUPDAT buffer.

8.6.1.4 EP01STAT

The Busy bits in EP0CS, EP1OUTCS, and EP1INCS (described later in this chapter) are replicated in this SFR; they are provided here in order to allow faster access (via the MOV instruction rather than MOVX) to those bits.

Three status bits are provided in the EP01STAT register; the status bits are the following:

- EP1INBSY. 1 = EP1IN is busy
- EP1OUTBSY. 1 = EP1OUT is busy
- EP0BSY. 1 = EP0 is busy

8.6.1.5 EP1OUTCS

This register is used to coordinate Bulk or Interrupt transfers over EP1OUT. The EP1OUTCS register contains two bits, Busy and Stall.

BUSY

This bit indicates when the firmware can read data from the Endpoint 1 OUT buffer. BUSY=1 means that the SIE 'owns' the buffer, so firmware should not read (or write) the buffer. BUSY=0 means that the firmware may read from (or write to) the buffer. A 1-to-0 Busy transition asserts the EP1OUT interrupt request, signaling that new EP1OUT data is available.

'Busy' is automatically cleared to '0' after the EZ-USB verifies the OUT data for accuracy and ACKs the transfer. If a transmission error occurs, the EZ-USB automatically retries the transfer; error recovery is transparent to the firmware.

Firmware arms the endpoint for OUT transfers by writing any value to the byte count register EP1OUTBC, which automatically sets BUSY=1.

At power-on (or whenever a 0-to-1 transition occurs on the RESET# pin), the Busy bit is set to '0', so the EZ-USB will NAK all EP1OUT transfers until the firmware arms EP1OUT by writing any value to EP1OUTBC.

STALL

Firmware sets STALL=1 to instruct the EZ-USB to return the Stall PID (instead of ACK or NAK) in response to an EP1OUT transfer. The EZ-USB continues to respond to EP1OUT transfers with the Stall PID until the firmware clears this bit.

8.6.1.6 EP1OUTBC

Firmware may read this 7-bit register to determine the number of bytes (0-64) in EP1OUTBUF.

Firmware writes any value to EP1OUTBC to arm an EP1OUT transfer.

8.6.1.7 EP1INCS

This register is used to coordinate Bulk or Interrupt transfers over EP1IN. The EP1INCS register contains two bits: Busy and Stall.

BUSY

This bit indicates when the firmware can load data into the Endpoint 1 IN buffer. BUSY=1 means that the SIE 'owns' the buffer, so firmware should not write (or read) the buffer. BUSY=0 means that the firmware may write data into (or read from) the buffer. A 1-to-0 Busy transition asserts the EP1IN interrupt request, signaling that the EP1IN buffer is free and ready to be loaded with new data.

The firmware schedules an IN transfer by loading up to 64 bytes of data into EP1INBUF, then writing the byte count register EP1INBC with the number of bytes loaded (0-64). Writing the byte count register automatically sets BUSY=1, indicating that the transfer over USB is pending. After the EZ-USB subsequently receives an IN token, sends the data, and successfully receives an ACK from the host, Busy is automatically cleared to '0' to indicate that the buffer is ready to accept more data. This generates the EP1IN interrupt request, which signals that the buffer is again available.

At power on, or whenever a 0-to-1 transition occurs on the RESET# pin, the Busy bit is set to '0', meaning that the EZ-USB will NAK all EP1IN transfers until the firmware arms the endpoint by writing the number of bytes to transfer into the EP1INBC register.

STALL

Firmware sets STALL=1 to instruct the EZ-USB to return the Stall PID (instead of ACK or NAK) in response to an EP1IN

transfer. The EZ-USB continues to respond to EP1IN transfers with the Stall PID until the firmware clears this bit.

8.6.1.8 EP1INBC

Firmware arms an IN transfer by loading this 7-bit register with the number of bytes (0-64) it has previously loaded into EP1INBUF.

8.6.2 Registers That Control EP2, EP4, EP6, EP8

Note In order to achieve the high transfer rates required by USB 2.0's high-speed mode, and to maximize full-speed transfer rates, the EZ-USB's CPU should not participate in transfers to and from the 'large' endpoints. Instead, those endpoints are usually connected directly to external logic (see chapters [Slave FIFOs, on page 99](#) and [General Programmable Interface, on page 121](#) for details). Although especially suited for high-speed (480 Mbits/sec) transfers, the functionality of these endpoints is identical at full speed, except for packet size.

Some applications, however, may require the firmware to have at least some small amount of control over the large endpoints. For those applications, the EZ-USB provides the registers shown in [Table 8-5](#).

Table 8-5. Registers that Control EP2,EP4,EP6 and EP8

Address	Name	Function
SFR 0xAA	EP2468STAT	EP2, 4, 6, 8 empty/full
0xE648	INPKTEND	force end of IN packet
0xE649	OUTPKTEND	skip or commit an OUT packet
0xE640	EP2ISOINPKTS	ISO IN packets per frame or microframe
0xE6A3	EP2CS	npak, full, empty, stall
0xE690	EP2BCH	byte count (H)
0xE691	EP2BCL	byte count (L)
0xE641	EP4ISOINPKTS	ISO IN packets per frame or microframe
0xE6A4	EP4CS	npak, full, empty, stall
0xE694	EP4BCH	byte count (H)
0xE695	EP4BCL	byte count (L)
0xE642	EP6ISOINPKTS	ISO IN packets per frame/microframe
0xE6A5	EP6CS	npak, full, empty, stall
0xE698	EP6BCH	byte count (H)
0xE699	EP6BCL	byte count (L)
0xE643	EP8ISOINPKTS	ISO IN packets per frame/microframe
0xE6A6	EP8CS	npak, full, empty, stall
0xE69C	EP8BCH	byte count (H)
0xE69D	EP8BCL	byte count (L)

8.6.2.1 EP2468STAT

The Endpoint Full and Endpoint Empty status bits (described below, in section [Section 8.6.2.3](#)) are replicated here in order to allow faster access by the firmware.

8.6.2.2 EP2ISOINPKTS, EP4ISOINPKTS, EP6ISOINPKTS, EP8ISOINPKTS

These registers only apply to ISOCHRONOUS IN endpoints. Refer to the EPxISOINPKTS register descriptions in the [Registers chapter on page 211](#) for details.

FX2LP has the capability of sending a zero-length packet (ZLP) when the host issues an IN token to an isochronous IN endpoint and the SIE does not have any data available.

These registers do not affect full-speed (12 Mbps) operation; full-speed isochronous transfers are always fixed at one packet per frame.

8.6.2.3 EP2CS, EP4CS, EP6CS, EP8CS

Because the four large EZ-USB endpoints offer double, triple or quad buffering, a single Busy bit is not sufficient to convey the state of these endpoint buffers. Therefore, these endpoints have multiple bits (NPAK, FULL, EMPTY) that can be inspected in order to determine the state of the endpoint buffers.

Note Multiple-buffered endpoint data must be read or written only at the buffer addresses given in [Table 8-3 on page 89](#). The EZ-USB automatically switches the multiple buffers in and out of the single addressable buffer space.

NPAK[2:0] (EP2, EP6) and NPAK[1:0] (EP4, EP8)

NPAK values have different interpretations for IN and OUT endpoints:

- OUT Endpoints. NPAK indicates the number of packets received over USB and ready for the firmware to read.
- IN Endpoints. NPAK indicates the number of IN packets committed to USB (i.e., loaded and armed for USB transfer), and thus unavailable to the firmware.

The NPAK fields differ in size to account for the depth of buffering available to the endpoints. Only double buffering is available for EP4 and EP8 (two NPAK bits), and up to quad buffering is available for EP2 and EP6 (three NPAK bits).

FULL

While FULL and EMPTY apply to transfers in both directions, 'FULL' is more useful for IN transfers. It has the same meaning as 'Busy', but applies to multiple-buffered IN endpoints. FULL=1 means that all buffers are committed to USB, and none are available for firmware access.

For IN transfers, FULL=1 means that all buffers are committed to USB, so firmware should not load the endpoint buffer with any more data. When FULL=1, NPAK holds 2, 3, or 4

depending on the buffering depth (double, triple or quad). This indicates that all buffers are in use by the USB transfer logic. As soon as one buffer becomes available, FULL is cleared to '0' and NPAK is decremented by one, indicating that all but one of the buffers are committed to USB (i.e., one is available for firmware access). As IN buffers are transferred over USB, NPAK decrements to indicate the number still pending, until all are sent and NPAK=0.

EMPTY

While FULL and EMPTY apply to transfers in both directions, EMPTY is more useful for OUT transfers. EMPTY=1 means that the buffers are empty; all received packets (2, 3, or 4, depending on the buffering depth) have been serviced.

STALL

Firmware sets STALL=1 to instruct the EZ-USB to return the Stall PID (instead of ACK or NAK) in response to an IN or OUT transfer. The EZ-USB continues to respond to IN or OUT transfers with the Stall PID until the firmware clears this bit.

8.6.2.4 EP2BCH:L, EP4BCH:L, EP6BCH:L, EP8BCH:L

Endpoints EP2 and EP6 have 11-bit byte count registers to account for their maximum buffer sizes of 1024 bytes. Endpoints EP4 and EP8 have 10-bit byte count registers to account for their maximum buffer sizes of 512 bytes.

The byte count registers function similarly to the EP0 and EP1 byte count registers:

- For an IN transfer, the firmware loads the byte count registers to arm the endpoint (if EPxBCH must be loaded, it should be loaded first, since the endpoint is armed when EPxBCL is loaded).
- For an OUT transfer, the firmware reads the byte count registers to determine the number of bytes in the buffer, then writes any value to the low byte count register to re-arm the endpoint. See the 'Skip' section, below, for further details.

SKIP

Normally, the CPU interface and outside-logic interface to the endpoint FIFOs are independent, with separate sets of control bits for each interface. The AUTOOUT mode and the SKIP bit implement an 'overlap' between these two domains. A brief introduction to the AUTOOUT mode is given below; full details appear in the [Slave FIFOs chapter on page 99](#)

When outside logic is connected to the interface FIFOs, the normal data flow is for the EZ-USB to commit OUT data packets to the outside interface FIFO as they become available. This ensures an uninterrupted flow of OUT data from the host to the outside world, and preserves the high bandwidth required by the high-speed mode.

In some cases, it may be desirable to insert a 'hook' into this data flow, so that – rather than the EZ-USB automatically committing the packets to the outside interface as they are received over USB – firmware receives an interrupt for every received OUT packet, then has the option either to commit the packet to the outside interface (the output FIFO), or to discard it. The firmware might, for example, inspect a packet header to make this skip/commit decision.

To enable this 'hook', the AUTOOUT bit is cleared to '0'. If AUTOOUT = 0 and an OUT endpoint is re-armed by writing to its low byte-count register, the actual value written to the register becomes significant:

- If the SKIP bit (bit 7 of each EPxBCL register) is cleared to '0', the packet is committed to the output FIFO and thereby made available to the FIFO's master (either external logic or the internal GPIF).
- If the SKIP bit is set to '1', the just-received OUT packet is not committed to the output FIFO for transfer to the external logic; instead, the packet is ignored, its buffer is immediately made available for the next OUT packet, and the output FIFO (and external logic) never even 'knows' that it arrived.

Note The AUTOOUT bit appears in bit 4 of the Endpoint FIFO Configuration Registers EP2FIFOCFG, EP4FIFOCFG, EP6FIFOCFG and EP8FIFOCFG.

8.6.3 Registers That Control All Endpoints

Table 8-6. Registers That Control All Endpoints

Address	Name	Description
0xE658	IBNIE	IN-BULK-NAK individual interrupt enables
0xE659	IBNIRQ	IN-BULK-NAK individual interrupt requests
0xE65A	NAKIE	PING plus combined IBN-interrupt enable
0xE65B	NAKIRQ	PING plus combined IBN-interrupt request
0xE65C	USBIE	SUTOK, SUDAV, EP0-ACK, SOF interrupt enables
0xE65D	USBIRQ	SUTOK, SUDAV, EP0-ACK, and SOF interrupt requests
0xE65E	EPIE	Endpoint interrupt enables
0xE65F	EPIRQ	Endpoint interrupt requests
0xE662	USBERRIE	USB error interrupt enables
0xE663	USBERRIE	USB error interrupt requests
0xE664	ERRCNTLIM	USB error counter and limit
0xE665	CLRERRCNT	Clear error count
0xE683	TOGCTL	Endpoint data toggles

8.6.3.1 IBNIE, IBNIRQ, NAKIE, NAKIRQ

These registers contain the interrupt-enable and interrupt-request bits for two endpoint conditions: IN-BULK-NAK and PING.

IN-BULK-NAK

When the host requests an IN packet from an EZ-USB BULK endpoint, the endpoint NAKs (returns the NAK PID) until the endpoint buffer is filled with data and armed for transfer, at which point the EZ-USB answers the IN request with data.

Until the endpoint is armed, a flood of IN-NAKs can tie up bus bandwidth. Therefore, if the IN endpoints are not always kept full and armed, it may be useful to know when the host is 'knocking at the door', requesting IN data.

The IN-BULK-NAK (IBN) interrupt provides this notification. The IBN interrupt fires whenever a Bulk endpoint NAKs an IN request. The IBNIE/IBNIRQ registers contain individual enable and request bits per endpoint, and the NAKIE/NAKIRQ registers each contain a single bit, IBN, that is the OR'd combination of the individual bits in IBNIE/IBNIRQ, respectively.

Firmware enables an interrupt by setting the enable bit high, and clears an interrupt request bit by writing a '1' to it.

Note The EZ-USB interrupt system is described in detail in the [Interrupts chapter on page 59](#)

The IBNIE register contains an individual interrupt-enable bit for each endpoint: EP0, EP1, EP2, EP4, EP6, and EP8. These bits are valid only if the endpoint is configured as a Bulk or Interrupt endpoint. The IBNIRQ register similarly contains individual interrupt request bits for the six endpoints.

The IBN interrupt-service routine should take the following actions, in this order:

1. Clear the USB (INT2) interrupt request (by writing '0' to it).
2. Inspect the endpoint bits in IBNIRQ to determine which IN endpoint just NAK'd.
3. Take the required action (set a flag, arm the endpoint, etc.), then clear the individual IBN bit in IBNIRQ for the serviced endpoint (by writing '1' to it).
4. Repeat steps (2) and (3) for any other endpoints that require IBN service, until all IRQ bits are cleared.
5. Clear the IBN bit in the NAKIRQ register (by writing '1' to it).

Note Because the IBN bit represents the OR'd combination of the individual IBN interrupt requests, it does not 'fire' again until all individual IBN interrupt requests have been serviced and cleared.

PING

PING is the 'flip side' of IBN; it is used for high-speed (480 Mbps) Bulk OUT transfers. Thus, PING is only applicable to the FX2LP.

When operating at full speed, every host OUT transfer consists of the OUT PID and the endpoint data, even if the end-

point is NAKing (not ready). While the endpoint is not ready, the host repeatedly sends all the OUT data; if it is repeatedly NAK'd, bus bandwidth is wasted.

USB 2.0 introduced a new mechanism, called PING, that makes better use of bus bandwidth for 'unready' Bulk OUT endpoints.

At high speed, the host can 'ping' a Bulk OUT endpoint to determine if it is ready to accept data, holding off the OUT data transfer until it can actually be accepted. The host sends a PING token, and the FX2LP responds with:

- An ACK to indicate that there is space in the OUT endpoint buffer
- A NAK to indicate 'not ready, try later'.

The PING interrupts indicate that an FX2LP Bulk OUT endpoint returned a NAK in response to a PING.

Note PING only applies at high speed (480 Mbps).

Unlike the IBN bits, which are combined into a single IBN interrupt for all endpoints, each Bulk OUT endpoint has a separate PING interrupt (EP0PING, EP1PING, EP2PING, ..., EP8PING). Interrupt-enables for the individual interrupts are in the NAKIE register; the interrupt-requests are in the NAKIRQ register.

The interrupt service routine for the PING interrupts should perform the following steps, in the order shown:

1. Clear the INT2 interrupt request.
2. Take the action for the requesting endpoint.
3. Clear the appropriate EPxPING bit for the endpoint.

8.6.3.2 *EPIE, EPIRQ*

These registers are used to manage interrupts from the EZ-USB endpoints. In general, an interrupt request is asserted whenever the following occurs:

- An IN endpoint buffer becomes available for the CPU to load.
- An OUT endpoint has new data for the CPU to read.

For the small endpoints (EP0 and EP1IN/OUT), these conditions are synonymous with the endpoint Busy bit making a 1-to-0 transition (busy to not-busy). As with all EZ-USB interrupts, this one is enabled by writing a '1' to its enable bit, and the interrupt flag is cleared by writing a '1' to it.

Note Do not attempt to clear an IRQ bit by reading the IRQ register, OR'ing its contents with a bit mask (for example, 00010000), then writing the contents back to the register. Since a '1' clears an IRQ bit, this clears all the asserted IRQ bits rather than just the desired one. Instead, simply write a single '1' (for example, 00010000) to the register.

8.6.3.3 *USBERRIE, USBERRIRQ, ERRCNTLIM, CLRERRCNT*

These registers are used to monitor the 'health' of the USB connection between the EZ-USB and the host.

USBERRIE

This register contains the interrupt-enable bits for the 'Isochronous Endpoint Error' interrupts and the 'USB Error Limit' interrupt.

An 'Isochronous Endpoint Error' occurs when the FX2LP detects a PID sequencing error for a high-bandwidth, high-speed ISO endpoint.

USBERRIQ

This register contains the interrupt flags for the 'Isochronous Endpoint Error' interrupts and the 'USB Error Limit' interrupt.

ERRCNTLIM

EZ-USB firmware sets the USB error limit to any value from 1 to 15 by writing that value to the lower nibble of this register; when that many USB errors (CRC errors, Invalid PIDs, garbled packets, etc.) have occurred, the 'USB Error Limit' interrupt flag is set. At power-on-reset, the error limit defaults to 4 (0100 binary).

The upper nibble of this register contains the current USB error count.

CLRERRCNT

Writing any value to this register clears the error count in the upper nibble of ERRCNTLIM. The lower nibble of ERRCNTLIM is not affected.

8.6.3.4 TOGCTL

As described in the [Introducing EZ-USB® chapter on page 13](#) the host and device maintain a *data toggle* bit,

which is toggled between data packet transfers. There are certain times when the firmware must reset an endpoint's data toggle bit to '0':

- After a configuration changes (for example, after the host issues a Set Configuration request).
- After an interface's alternate setting changes (i.e., after the host issues a Set Interface request).
- After the host sends a 'Clear Feature - Endpoint Stall' request to an endpoint.

For the first two, the firmware must clear the data toggle bits for all endpoints contained in the affected interfaces. For the third, only one endpoint's data toggle bit is cleared.

The TOGCTL register contains bits to set or clear an endpoint data toggle bit, as well as to read the current state of a toggle bit.

At this writing, there is no known reason for firmware to set an endpoint toggle to '1'. Also, since the EZ-USB handles all data toggle management, normally there is no reason to know the state of a data toggle. These capabilities are included in the TOGCTL register for completeness and debug purposes.

A two-step process is employed to clear an endpoint data toggle bit to '0'. First, writes the TOGCTL register with an endpoint address (EP3:EP0) plus a direction bit (I/O). Then, keeping the endpoint and direction bits the same, write a '1' to the 'R' (reset) bit. For example, to clear the data toggle for EP6 configured as an 'IN' endpoint, write the following values sequentially to TOGCTL:

- 00010110
- 00110110

TOGCTL							Data Toggle Control	E683
b7	b6	b5	b4	b3	b2	b1	b0	
Q	S	R	I/O	EP3	EP2	EP1	EP0	
R	R/W	R/W	R/W	R/W	R/W	R/W	R/W	
x	x	x	x	x	x	x	x	

8.7 The Setup Data Pointer

The USB host sends device requests using Control transfers over endpoint 0. Some requests require the EZ-USB to return data over EP0. During enumeration, for example, the host issues Get Descriptor requests that ask for the device's capabilities and requirements. The returned data can span many packets, so it must be partitioned into packet-sized blocks, then the blocks must be sent at the appropriate times (for example, when the EP0 buffer becomes ready).

The Setup Data Pointer automates this process of returning IN data over EP0, simplifying the firmware.

Note For the Setup Data Pointer to work properly, EP0's MaxPacketSize must be set to 64, and the address of SUDPTRH:L must be word-aligned (for example, the LSB of SUDPTRL must be '0').

Table 8-7 lists the registers which configure the Setup Data Pointer.

Table 8-7. Registers Used To Control the Setup Data Pointer

Address	Register Name	Function
0xE6B3	SUDPTRH	High address
0xE6B4	SUDPTRL	Low address
0xE6B5	SUDPTRCTL	SDPAUTO bit

To send a block of data, the block's word-aligned starting address is loaded into SUDPTRH:L. The block length must previously have been set; the method for accomplishing this depends on the state of the SDPAUTO bit:

- **SDPAUTO = 0 (Manual Mode):** Used for general-purpose block transfers. Firmware writes the block length to EP0BCH:L.
- **SDPAUTO = 1 (Auto Mode):** Used for sending Device, Configuration, String, Device Qualifier, and Other Speed Configuration descriptors *only*. The block length is automatically read from the 'length' field of the descriptor itself; no explicit loading of EP0BCH:L is necessary.

Writing to SUDPTRL starts the transfer; the EZ-USB automatically sends the entire block, packetizing as necessary.

For example, to answer a *Get Descriptor - Device* request, firmware sets SDPAUTO = 1, then loads the address of the device descriptor into SUDPTRH:L. The EZ-USB then automatically loads the EP0 data buffer with the required number of packets and transfers them to the host.

To command the EZ-USB to ACK the status (handshake) packet, the firmware clears the HSNACK bit (by writing '1' to it) before starting the Setup Data Pointer transfer.

If the firmware needs to know when the transaction is complete (for example, sent and acknowledged), it can enable the EP0ACK interrupt before starting the Setup Data Pointer transfer.

Note When SDPAUTO = 0, writing to EP0BCH:L only sets the block length; it does not arm the transfer (the transfer is armed by writing to SUDPTRL). Therefore, before performing an EP0 transfer which does not use the Setup Data Pointer (i.e., one which is meant to be armed by writing to EP0BCL), SDPAUTO must be set to '1'.

8.7.1 Transfer Length

When the host makes any EP0IN request, the EZ-USB respects the following two length fields:

- the requested number of bytes (from the last two bytes of the SETUP packet received from the host)
- the available number of bytes, supplied either as a length field in the actual descriptor (SDPAUTO = 1) or in EP0BCH:L (SDPAUTO = 0)

In accordance with the USB Specification, the EZ-USB sends the smaller of these two length fields.

8.7.2 Accessible Memory Spaces

The Setup Data Pointer can access data in either of two RAM spaces:

- On-chip Main RAM (16 KB at 0x0000-0x3FFF)
- On-chip Scratch RAM (512 bytes at 0xE000-0xE1FF)

Note The Setup Data Pointer cannot be used to access off-chip memory at any address.

8.8 Autopointers

Endpoint data is available to the CPU in RAM buffers (see Table 8-3 on page 89). In some cases, it is faster for the firmware to access endpoint data as though it were in a FIFO register. The EZ-USB provides two special data pointers, called 'Autopointers', that automatically increment after each byte transfer. Using the Autopointers, firmware can access contiguous blocks of on- or off-chip data memory as a FIFO.

Each Autopointer is controlled by a 16-bit address register (AUTOPTRnH:L), a data register (XAUTODATn), and a control bit (APTRnINC). An additional control bit, APTREN, enables both Autopointers.

A read from (or write to) an Autopointer data register actually accesses the address pointed to by the corresponding Autopointer address register, which increments on every data-register access. To read or write a contiguous block of memory (for example, an endpoint buffer) using an Autopointer, load the Autopointer's address register with the starting address of the block, then repeatedly read or write the Autopointer's data register.

The AUTOPTRnH:L registers may be written or read at any time to determine the current Autopointer address.

Most of the Autopointer registers are in SFR Space for quick access; the data registers are available only in External Data space.

Table 8-8. Registers that control the Autopointers

Address	Register Name	Function
SFR 0xAF	AUTOPTRSETUP	Increment/freeze, off-chip access enable
SFR 0x9A	AUTOPTR1H	Address high
SFR 0x9B	AUTOPTR1L	Address low
0xE67B	XAUTODAT1	Data
SFR 0x9D	AUTOPTR2H	Address high
SFR 0x9E	AUTOPTR2L	Address low
0xE67C	XAUTODAT2	Data

The Autopointers are configured using three bits in the AUTOPTRSETUP register: one bit (APTREN) enables both

autopointers, and two bits (one for each Autopointer, called APTR1INC and APTR2INC, respectively) control whether or not the address increments for every Autodata access.

Enabling the Autopointers has one side effect: Any 'code' access (an instruction fetch, for instance) from addresses 0xE67B and 0xE67C returns the AUTODATA values, rather than the code-memory values at these two addresses. This introduces a two-byte 'hole' in the code memory.

Note There is no 2-byte hole in the data memory at 0xE67B:E67C; the hole only appears in the program memory.

Note The Autopointers must not be used to read or write registers in the 0xE600 to 0xE6FF range; Autopointer accesses within that range produce undefined results.



9. Slave FIFOs



9.1 Introduction

Although some EZ-USB-based devices may use the EZ-USB's CPU to process USB data directly (See chapter "Access to Endpoint Buffers" on page 87), most use the EZ-USB simply as a conduit between the USB and external data processing logic (for example, an ASIC or DSP, or the IDE controller on a hard disk drive).

In devices with external data-processing logic, USB data flows between the host and that external logic — usually without any participation by the EZ-USB's CPU — through the EZ-USB's internal 'endpoint FIFOs'. To the external logic, these endpoint FIFOs look like most others; they provide the usual timing signals, handshake lines (full, empty, programmable level), read and write strobes, output enable, and others.

These FIFO signals must, of course, be controlled by a FIFO 'master'. The EZ-USB's General Programmable Interface (GPIF) can act as an 'internal' master when the EZ-USB is connected to external logic which does not include a standard FIFO interface (General Programmable Interface, on page 121 discusses the internal-master GPIF), or the FIFOs can be controlled by an external master. While its FIFOs are controlled by an external master, the EZ-USB is said to be in 'Slave FIFO' mode.

This chapter provides details on the interface — both hardware and software — between the EZ-USB's slave FIFOs and an 'external' master.

9.2 Hardware

Figure 9-1 illustrates the four slave FIFOs. The figure shows the FIFOs operating in 16 bit mode, although they can also be configured for 8-bit operation.

Figure 9-1. Slave FIFOs' Role in the EZ-USB System

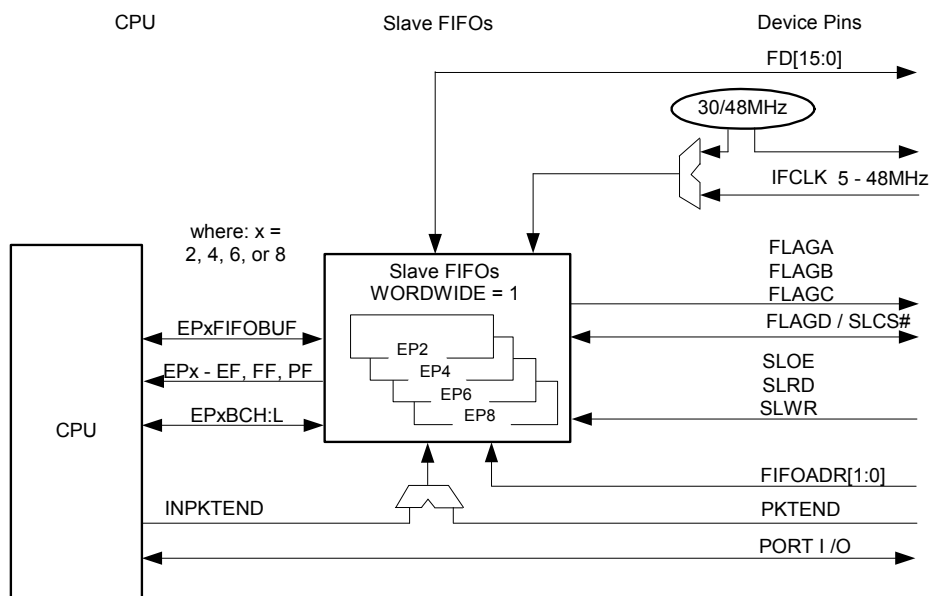

Table 9-1 lists the registers associated with the slave FIFO hardware. The registers are fully described in the Registers chapter on page 211

Table 9-1. Registers Associated with Slave FIFO Hardware

Register Name	
IFCONFIG	EPxFIFOPFH/L
PINFLAGSAB	PORTACFG
PINFLAGSCD	INPKTEND
FIFORESET	EPxFIFOIE
FIFOPINPOLAR	EPxFIFOIRQ
EPxCFG	EPxFIFOBCH:L
EPxFIFOCFG	EPxFLAGS
EPxAUTOINLENH:L	EPxFIFOBUF

9.2.1 Slave FIFO Pins

The EZ-USB comes out of reset with its I/O pins configured in 'Ports' mode, not 'Slave FIFO' mode. To configure the pins for Slave FIFO mode, the IFCFG[1:0] bits in the IFCONFIG register must be set to '11' (see Table 13-10, "IFCFG Selection of Port I/O Pin Functions," on page 188 for details). When IFCFG1:0 = 11, the Slave FIFO interface pins are presented to the external master, as shown in Figure 9-2.

Figure 9-2. EZ-USB Slave Mode Full Featured Interface Pins

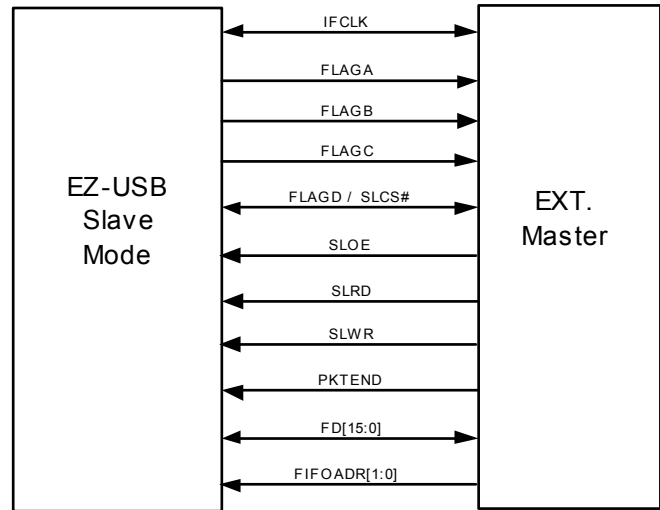

External logic accesses the FIFOs through an 8- or 16-bit wide data bus, FD. The data bus is bidirectional, with its output drivers controlled by the SLOE pin.

The FIFOADR[1:0] pins select which of the four FIFOs is connected to the FD bus and is being controlled by the external master.

In asynchronous mode (IFCONFIG.3 = 1), SLRD and SLWR are read and write strobes; in synchronous mode (IFCONFIG.3 = 0), SLRD and SLWR are enables for the IFCLK clock pin.

Figure 9-3. Asynchronous vs. Synchronous Timing Models

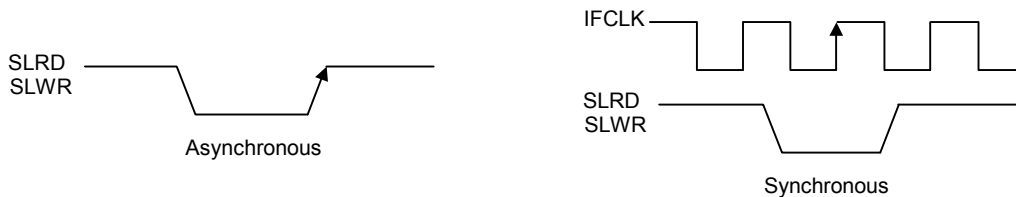

9.2.2 FIFO Data Bus

The FIFO Data (FD) bus, FD[x:0], can be either 8- or 16-bits wide. The width is selected via each FIFO's WORDWIDE bit, (EPxFIFOCFG.0):

- WORDWIDE = 0: 8-bit mode. FD[7:0] replaces Port B. See [Figure 9-4](#).
- WORDWIDE = 1: 16-bit mode. FD[15:8] replaces Port D and FD[7:0] replaces Port B. See [Figure 9-5](#). FD[7:0] is the LSB of the word, and FD[15:8] is the MSB of the word.

On a hard reset, the FIFO data bus defaults to 16-bit mode (WORDWIDE = 1) for all FIFOs.

In either mode, the FIFOADR[1:0] pins select which of the four FIFOs is internally connected to the FD pins.

Note If all of the FIFOs are configured for 8-bit mode, Port D remains available for use as general-purpose I/O. If any FIFO is configured for 16-bit mode, Port D is unavailable for use as general-purpose I/O regardless of which FIFO is currently selected via the FIFOADR[1:0] pins.

Note In 16-bit mode, the EZ-USB only transfers even-sized packets of data across the FD bus. This should be considered when the EZ-USB interfaces to host software that sends or receives odd sized packets.

Figure 9-4. 8-bit Mode Slave FIFOs, WORDWIDE = 0

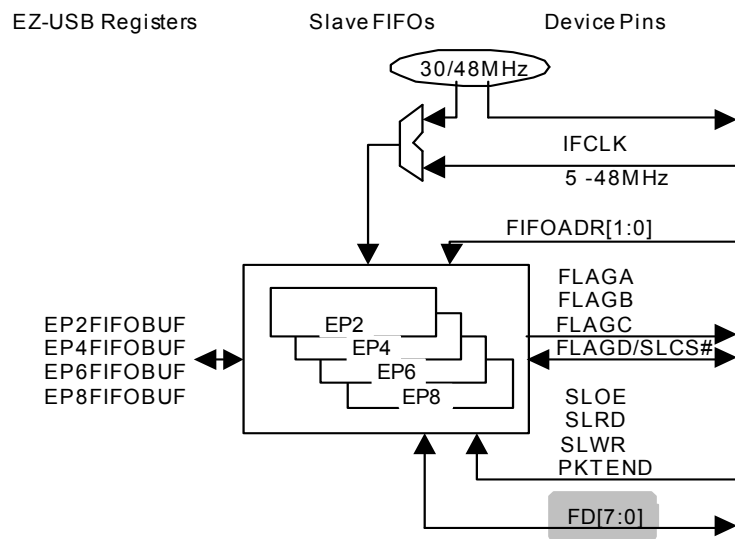
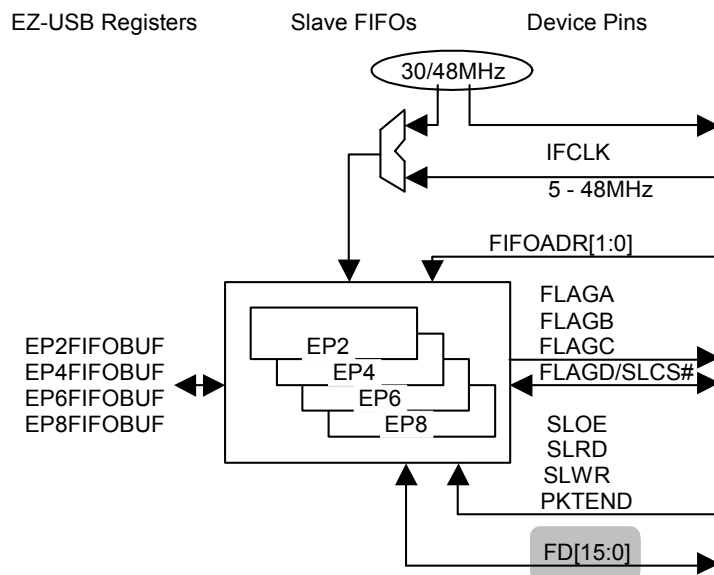

Figure 9-5. 16-bit Mode Slave FIFOs, WORDWIDE = 1



9.2.3 Interface Clock

The slave FIFO interface can be clocked from either an internal or an external source. The EZ-USB's internal clock source can be configured to run at either 30 or 48 MHz, and it can optionally be output on the interface clock (IFCLK) pin. If the EZ-USB is configured to use an external clock source, the IFCLK pin can be driven at any frequency between 5 MHz and 48 MHz. On a hard reset, the EZ-USB defaults to the internal source at 48 MHz, normal polarity, with the IFCLK output disabled. See [Figure 9-6](#).

IFCONFIG.7 selects between internal and external sources: 0 = external, 1 = internal. If an external IFCLK is chosen, it must be free running at a minimum frequency of 5 MHz. In addition, in order to provide synchronization for the internal endpoint FIFO logic, the external IFCLK source must be present before the firmware sets IFCONFIG.7 = 0.

IFCONFIG.6 selects between the 30- and 48-MHz internal clock: 0 = 30 MHz, 1 = 48 MHz. This bit has no effect when IFCONFIG.7 = 0.

IFCONFIG.5 is the output enable for the internal clock source: 0 = disable, 1 = enable. This bit must not be set to '1' when IFCONFIG.7 = 0.

IFCONFIG.4 inverts the polarity of the interface clock (either internal or external): 0 = normal, 1 = inverted. IFCLK inversion can make it easier to interface the EZ-USB with certain external circuitry. When an internal IFCLK is used (IFCONFIG.7 = 1), IFCONFIG.4 only affects the IFCLK output polarity if IFCONFIG.5 = 1. [Figure 9-7](#) demonstrates the use of IFCLK output inversion in order to ensure a long enough setup time (t_s) for reading the EZ-USB's FIFO flags.

Note When IFCLK is configured as an input, the minimum external frequency that can be applied to it is 5 MHz. This clock must be applied prior to initialization of the GPIF; only interruptions of it lower the overall frequency, causing violations of the minimum frequency requirement.

Figure 9-6. IFCLK Configuration

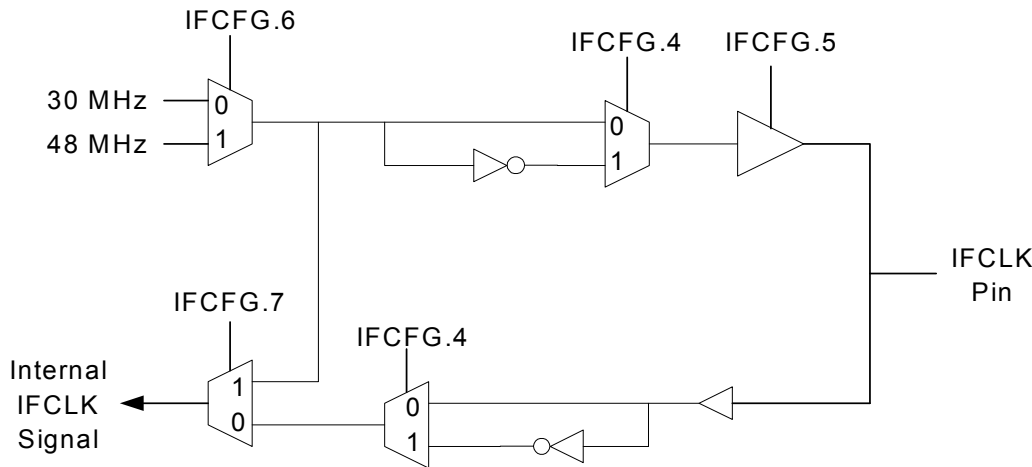
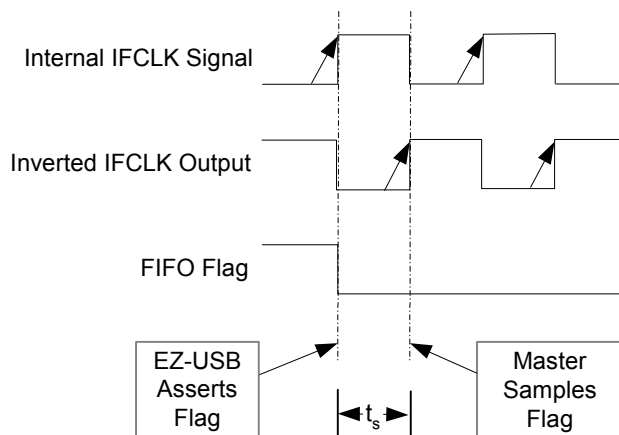

Figure 9-7. Satisfying Setup Timing by Inverting the IFCLK Output



9.2.4 FIFO Flag Pins (FLAGA, FLAGB, FLAGC, FLAGD)

Four pins — FLAGA, FLAGB, FLAGC, and FLAGD (see [Figure 9-7](#)) — report the status of the EZ-USB's FIFOs; in addition to the usual 'FIFO full' and 'FIFO empty' signals, there is also a signal which indicates that a FIFO has filled to a user-programmable level. The external master typically monitors the 'empty' flag (EF) of OUT endpoints and the full (FF) flag of IN endpoints; the programmable level flag (PF) is equally useful for either type of endpoint (it can, for instance, give advance warning that an OUT endpoint is almost empty or that an IN endpoint is almost full).

The FLAGA, FLAGB, and FLAGC pins can operate in either of two modes: Indexed or Fixed, as selected via the PIN-FLAGSAB and PINFLAGSCD registers. The FLAGD pin operates in Fixed mode only. FLAGA-FLAGC pins can be configured independently; some pins can be in Fixed mode while others are in Indexed mode. See the PINFLAGSAB and PINFLAGSCD register descriptions in the [Registers chapter on page 211](#) for complete details.

Flag pins configured for Indexed mode report the status of the FIFO currently selected by the FIFOADR[1:0] pins. When configured for Indexed mode, FLAGA reports the programmable level status, FLAGB reports the 'full' status, and FLAGC reports the 'empty' status.

Flag pins configured for Fixed mode report one of the three conditions for a specific FIFO, regardless of the state of the FIFOADR[1:0] pins. The condition and FIFO are user-selectable. For example, FLAGA could be configured to report FIFO2's 'empty' status, FLAGB to report FIFO4's 'empty' status, FLAGC to report FIFO4's 'programmable level' status, and FLAGD to report FIFO6's 'full' status.

The polarity of the 'empty' and 'full' flag pins defaults to active-low but may be inverted via the FIFOPINPOLAR register.

On a hard reset, the FIFO flags are configured for Indexed operation.

Figure 9-8. FLAGx Pins

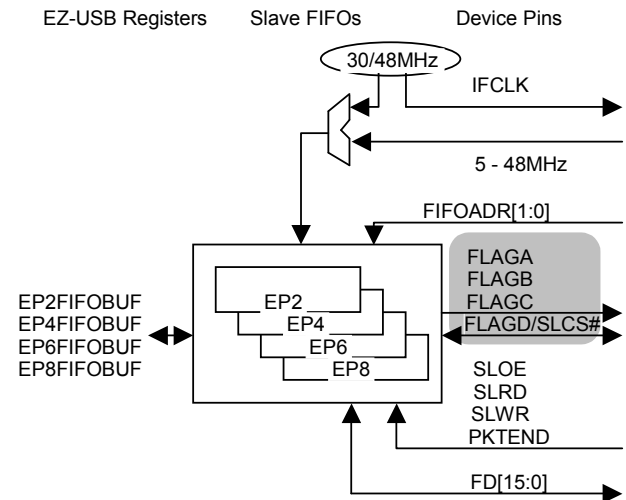

9.2.5 Control Pins (SLOE, SLRD, SLWR, PKTEND, FIFOADR[1:0])

The Slave FIFO 'control' pins are SLOE (Slave Output Enable), SLRD (Slave Read), SLWR (Slave Write), PKTEND (Packet End), and FIFOADR[1:0] (FIFO Select). 'Read' and 'Write' are from the external master's point of view; the external master reads from OUT endpoints and writes to IN endpoints. See [Figure 9-9 on page 104](#).

Slave Output Enable and Slave Read — SLOE and SLRD:

In synchronous mode (IFCONFIG.3 = 0), the FIFO pointer is incremented on each rising edge of IFCLK while SLRD is asserted. In asynchronous mode (IFCONFIG.3 = 1), the FIFO pointer is incremented on each asserted-to-deasserted transition of SLRD.

The SLOE pin enables the FD outputs. In synchronous mode, when SLOE is asserted, this causes the FD bus to be driven with the data that the FIFO pointer is currently pointing to. The data is pre-fetched and is output only when SLOE is asserted. In asynchronous mode, the data is not pre-fetched, and SLRD must be asserted when SLOE is asserted for the FD bus to be driven with the data that the FIFO pointer is currently pointing to. SLOE has no other function besides enabling the FD bus to be in a driven state.

By default, SLOE and SLRD are active-low; their polarities can be changed via the FIFOPINPOLAR register.

Slave Write — SLWR

In synchronous mode (IFCONFIG.3 = 0), data on the FD bus is written to the FIFO (and the FIFO pointer is incremented) on each rising edge of IFCLK while SLWR is asserted. In asynchronous mode (IFCONFIG.3 = 1), data on the FD bus is written to the FIFO (and the FIFO pointer is incremented) on each asserted-to-deasserted transition of SLWR.

By default, SLWR is active-low; its polarity can be changed via the FIFOPINPOLAR register.

FIFOADR[1:0]:

The FIFOADR[1:0] pins select which of the four FIFOs is connected to the FD bus (and, if the FIFO flags are operating in Indexed mode, they select which FIFO's flags are presented on the FLAGx pins):

Table 9-2. FIFO Selection via FIFOADR[1:0]

FIFOADR[1:0]	Selected FIFO
00	EP2
01	EP4
10	EP6
11	EP8

PKTEND

An external master asserts the PKTEND pin to commit an IN packet to USB regardless of the packet's length. PKTEND is usually used when the master wishes to send a 'short' packet (for example, a packet smaller than the size specified in the EPxAUTOINLENH:L registers).

For example: Assume that EP4AUTOINLENH:L is set to the default of 512 bytes. If AUTOIN = 1, the external master can stream data to FIFO4 continuously, and (absent any bottlenecks in the data path) the EZ-USB automatically commits a packet to USB whenever the FIFO fills with 512 bytes. If the master wants to send a stream of data whose length is not a multiple of 512, the last packet is not be automatically committed to USB because it is smaller than 512 bytes. To commit that last packet, the master can do one of two things: It can pad the packet with dummy data in order to make it exactly 512 bytes long, or it can write the short packet to the FIFO, then pulse the PKTEND pin.

If the FIFO is configured to allow zero-length packets (EPxFIFOCFG.2 = 1), pulsing the PKTEND pin when a FIFO buffer is available commits a zero-length packet.

By default, PKTEND is active-low; its polarity can be changed via the FIFOPINPOLAR register.

Note The PKTEND pin must not be asserted unless a buffer is available, even if only a zero-length packet is being committed. The 'full' flag may be used to determine whether a buffer is available.

Note In synchronous mode, there is no specific timing requirement for PKTEND assertion with respect to SLWR

assertion. PKTEND can be asserted anytime. In asynchronous mode, SLWR and PKTEND should not be pulsed at the same time. PKTEND should be asserted after SLWR has been deasserted for the minimum deasserted pulse width. In both modes, FIFOADR[1:0] should be held constant during the PKTEND pin assertion.

Figure 9-9. Slave FIFO Control Pins

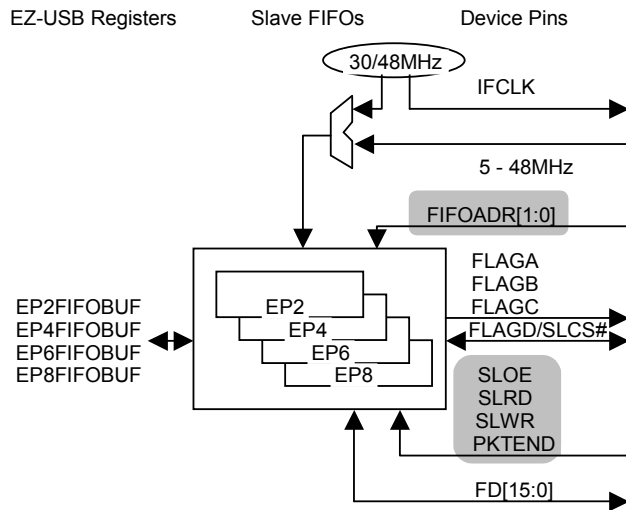

9.2.6 Slave FIFO Chip Select

The Slave FIFO Chip Select (SLCS#) pin is an alternate function of pin PA7; it is enabled via the PORTACFG.6 bit (see section 13.4.1 Port A Alternate Functions on page 185).

The SLCS# pin allows external logic to effectively remove the EZ-USB from the FIFO Data bus, in order to, for example, share that bus among multiple slave devices. For applications that do not need to share the FD bus among multiple slave devices, the SLCS# pin can be tied to GND to permanently select the EZ-USB slave FIFO interface. This configuration is assumed for the interface and timing examples that follow.

While the SLCS# pin is pulled high by external logic, the EZ-USB floats its FD[x:0] pins and ignores the SLOE, SLRD, SLWR, and PKTEND pins.

9.2.7 Implementing Synchronous Slave FIFO Writes

Figure 9-10. Interface Pins: Synchronous FIFO Writes

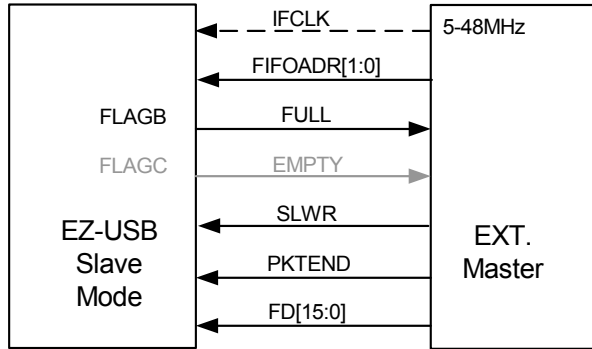

In order to implement synchronous FIFO writes, a typical sequence of events for the external master is:

- IDLE:** When a write event occurs, transition to State 1.
- STATE 1:** Point to IN FIFO, assert FIFOADR[1:0] (setup time must be met with respect to the rising edge of IFCLK), transition to State 2.
- STATE 2:** If FIFO-Full flag is false (FIFO not full), transition to State 3 else remain in State 2.
- STATE 3:** Drive data on the bus, assert SLWR (setup and hold times must be met with respect to the rising edge of IFCLK), deassert SLWR. Transition to State 4.

STATE 4: If more data to write, transition to State 2 else transition to IDLE.

Figure 9-11. State Machine: Synchronous FIFO Writes

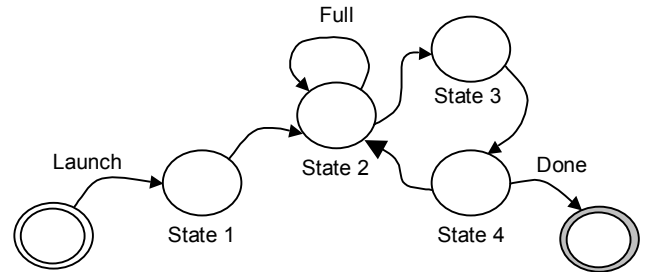

Figures 9-12 to 9-14 show timing examples of an external master performing synchronous FIFO writes to EP8. These examples assume that EP8 is configured as IN, Bulk, 512 bytes buffer size, 2x buffered, WORDWIDE = 1, AUTOIN = 1, EP8AUTOINLENH:L = 512. With AUTOIN = 1, and EP8AUTOINLENH:L = 512, this causes data packets to be automatically committed to USB whenever the master fills the FIFO with 512 bytes (or 256 words since WORDWIDE = 1).

In Figure 9-12, the external master selects EP8 by setting FIFOADR[1:0] to '11' and once it writes the first data value over the FD bus, FLAGC - EMPTY exhibits a 'not-empty' condition.

Figure 9-12. Timing Example: Synchronous FIFO Writes, Waveform 1

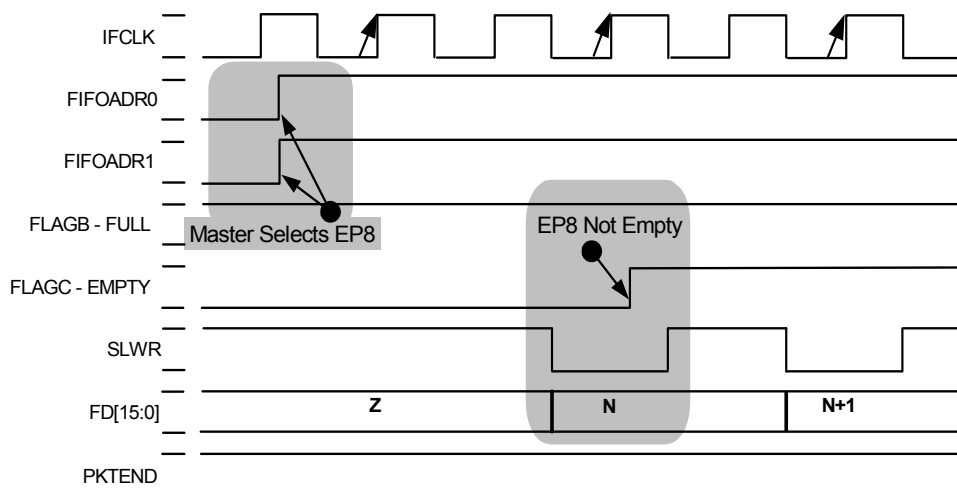
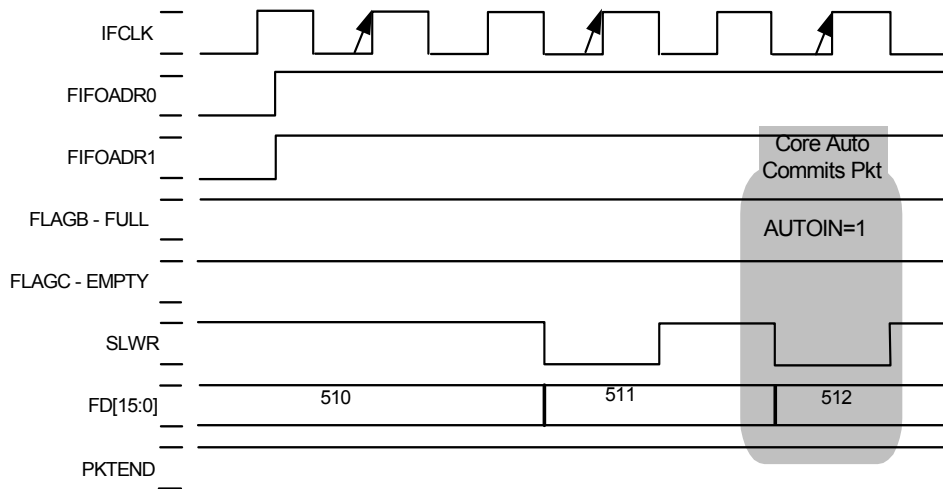

Figure 9-13. Timing Example: Synchronous FIFO Writes, Waveform 2



In Figure 9-13, once the external master writes the 512th word into the EP8 FIFO, the second 512-byte packet is automatically committed to USB. The first 512-byte packet was automatically committed to USB when the external master wrote the 256th word into the EP8 FIFO.

Figure 9-14 shows the fourth packet in the EP8 FIFO being manually committed by pulsing PKTEND. There is no specific timing requirement for PKTEND assertion with respect to SLWR assertion. Hence, PKTEND is asserted the same time the 816th word is written into EP8. This causes the short packet to be committed, which contains 48 words (or

96 bytes). The fourth packet would have been automatically committed if the external master finished writing the 1024th word.

Once the fourth packet has been committed, FLAGB - FULL is asserted, indicating that no more FIFO buffers are available for the external master to write into. A buffer becomes available once the host has read an entire packet.

Note FIFOADR[1:0] must be held constant during the PKTEND assertion.

Figure 9-14. Timing Example: Synchronous FIFO Writes, Waveform 3, PKTEND Pin Illustrated

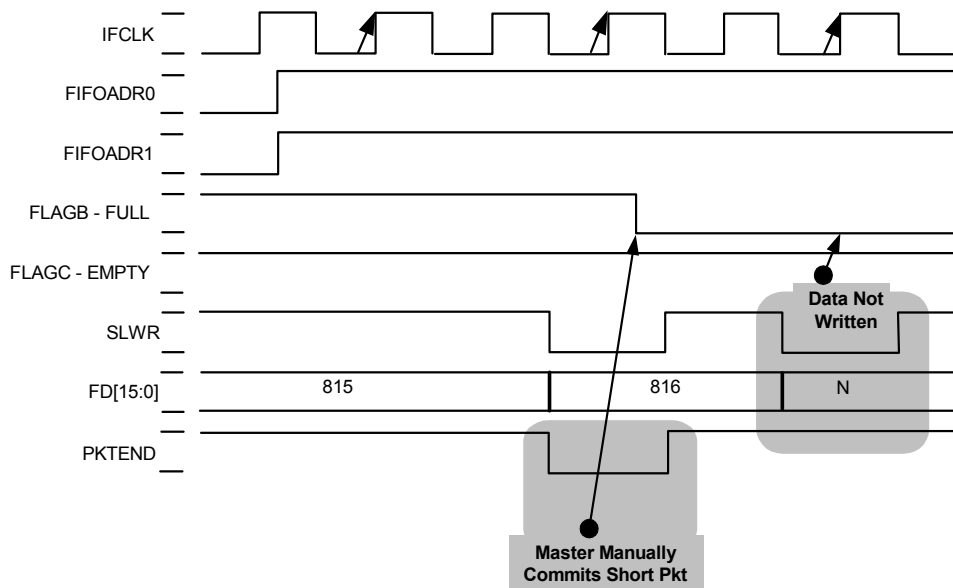

9.2.8 Implementing Synchronous Slave FIFO Reads

Figure 9-15. Interface Pins: Synchronous FIFO Reads

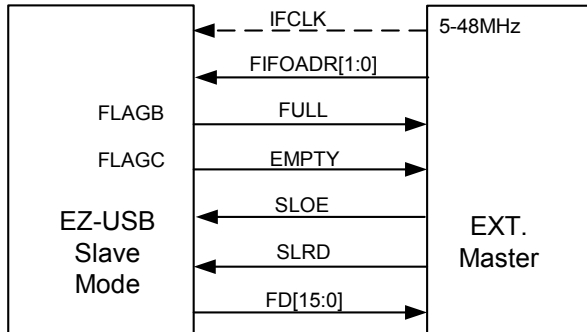

In order to implement synchronous FIFO reads, a typical sequence of events for the external master is:

IDLE. When a read event occurs, transition to State 1.

STATE 1: Point to OUT FIFO, assert FIFOADR[1:0] (setup time must be met with respect to the rising edge of IFCLK), transition to State 2.

STATE 2: Assert SLOE. If FIFO-Empty flag is false (FIFO not empty), transition to State 3 else remain in State 2.

STATE 3: Sample data on the bus, assert SLRD (setup and hold times must be met with respect to the rising edge of IFCLK), deassert SLRD. Deassert SLOE, transition to State 4.

Note Since SLOE has no other function than to enable the FD outputs, it is also correct to tie the SLRD and SLOE signals together.

STATE 4: If more data to read, transition to State 2 else transition to IDLE.

Figure 9-16. State Machine: Synchronous FIFO Reads

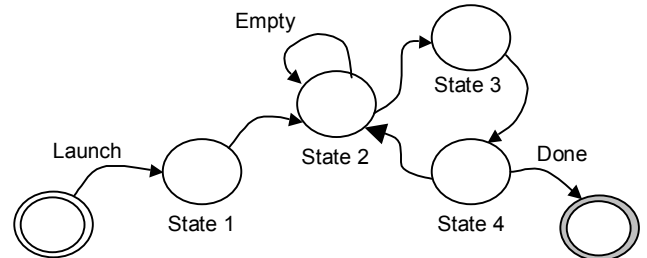

Figures 9-17 and 9-18 show timing examples of an external master performing synchronous FIFO reads from EP2. These examples assume that EP2 is configured as OUT, Bulk, 512 bytes buffer size, 2x buffered, WORDWIDE = 0, AUTOOUT = 1.

In Figure 9-17, the external master selects EP2 by setting FIFOADR[1:0] to 00. It asserts SLOE to turn on the FD output drivers, samples the first byte in the FIFO, and then pulses SLRD to increment the FIFO pointer.

Figure 9-17. Timing: Synchronous FIFO Reads, Waveform 1

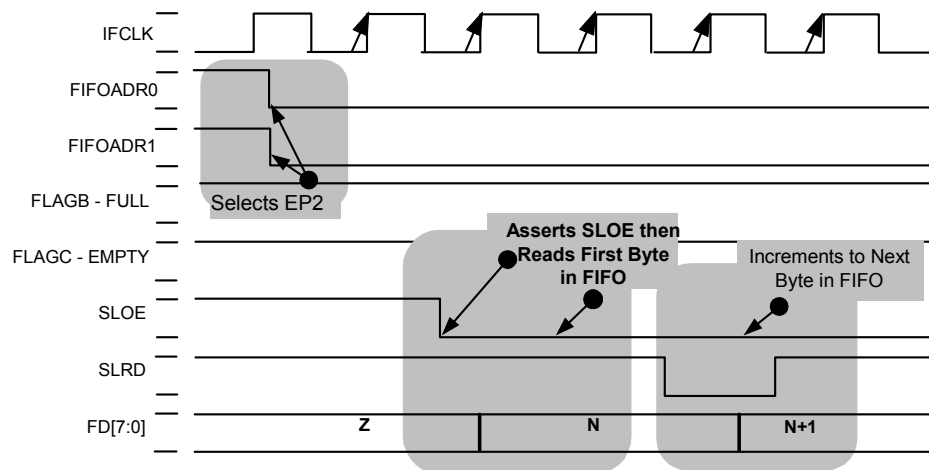

Figure 9-18. Timing Example: Synchronous FIFO Reads, Waveform 2, EMPTY Flag Illustrated

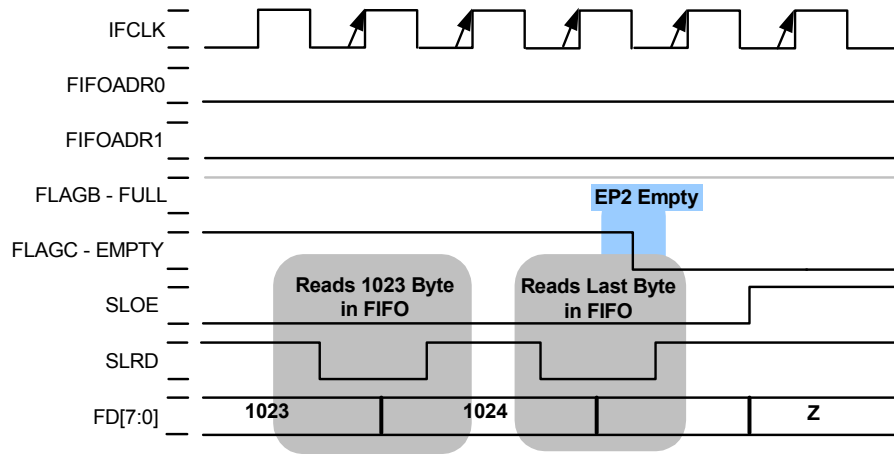
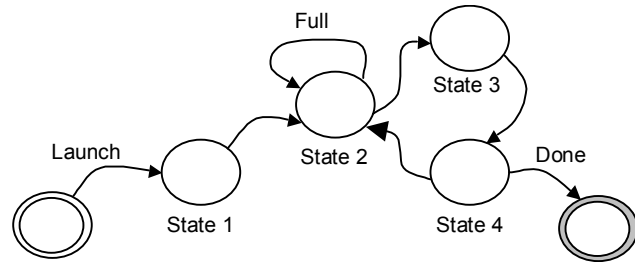
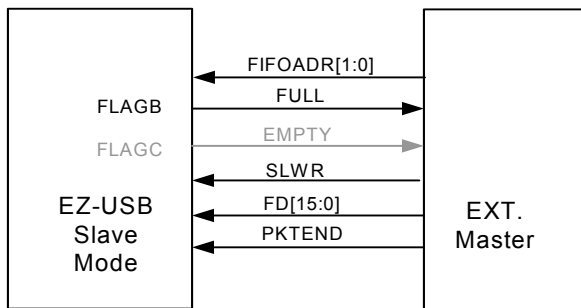

Figure 9-18 shows FLAGC - EMPTY assert after the master reads the 1024th (last) byte in the FIFO. This assumes that the host has only sent 1024 bytes to EP2.

Figure 9-20. State Machine: Asynchronous FIFO Writes

9.2.9 Implementing Asynchronous Slave FIFO Writes

Figure 9-19. Interface Pins: Asynchronous FIFO Writes



In order to implement asynchronous FIFO writes, a typical sequence of events for the external master is:

IDLE. When a write event occurs, transition to State 1.

STATE 1: Point to IN FIFO, assert FIFOADR[1:0] (setup time must be met with respect to the asserting edge of SLWR), transition to State 2.

STATE 2: If FIFO-Full flag is false (FIFO not full), transition to State 3 else remain in State 2.

STATE 3: Drive data on the bus (setup time must be met with respect to the deasserting edge of SLWR), write data to the FIFO and increment the FIFO pointer by asserting then deasserting SLWR, transition to State 4.

STATE 4: If more data to write, transition to State 2 else transition to IDLE.

Figure 9-21. Timing: Asynchronous FIFO Writes

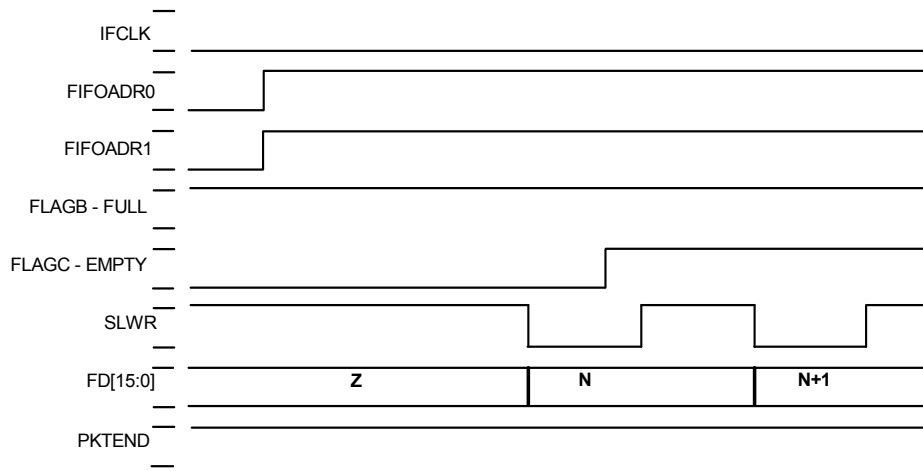

Figure 9-21 shows a timing example of asynchronous FIFO writes to EP8. The external master selects EP8 by setting FIFOADR[1:0] to 11. Once it writes the first data value over the FD bus, FLAGC - EMPTY exhibits a 'not empty' condition.

Note Since SLOE has no other function than to enable the FD outputs, it is also correct to tie the SLRD and SLOE signals together.

STATE 4: If more data to read, transition to State 2 else transition to IDLE.

9.2.10 Implementing Asynchronous Slave FIFO Reads

Figure 9-23. State Machine: Asynchronous FIFO Reads.

Figure 9-22. Interface Pins: Asynchronous FIFO Reads

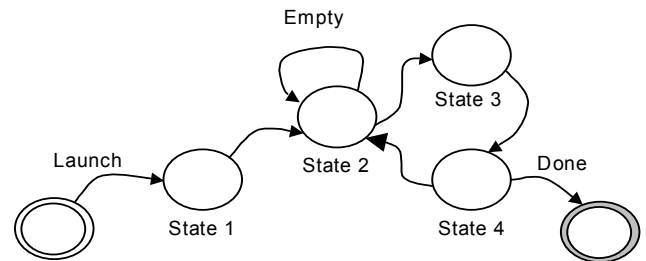
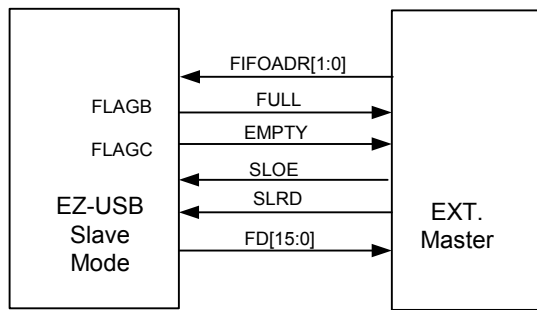

In order to implement asynchronous FIFO reads, a typical sequence of events for the external master is:

- IDLE: When a read event occurs, transition to State 1.
- STATE 1: Point to OUT FIFO, assert FIFOADR[1:0] (setup time must be met with respect to the asserting edge of SLRD), transition to State 2.
- STATE 2: If Empty flag is false (FIFO not empty), transition to State 3 else remain in State 2.
- STATE 3: Assert SLOE, assert SLRD, sample data on the bus, deassert SLRD (increment FIFO pointer), deassert SLOE, transition to State 4.

Figure 9-24. Timing: Asynchronous FIFO Reads

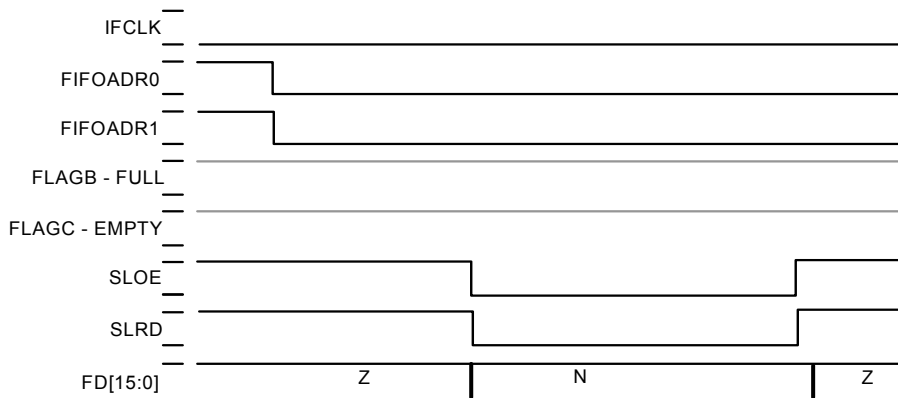

Figure 9-24 shows a timing example of asynchronous FIFO reads from EP2. The external master selects EP2 by setting FIFOADR[1:0] to 00, and strobos SLOE/SLRD to sample data on the FD bus.

9.3 Firmware

This section describes the interface between EZ-USB firmware and the FIFOs. More information is available in the [Access to Endpoint Buffers chapter on page 87](#).

Table 9-3. Registers Associated with Slave FIFO Firmware

Register Name	
EPxCFG	INPKTEND/OUTPKTEND
EPxFIFOCFG	EPxFIFOIE
EPxAUTOINLENH/L	EPxFIFOIRQ
EPxFIFOPFH:L	INT2IVEC
EP2468STAT	INT4IVEC
EP24FIFOFLGS	INTSETUP
EP68FIFOFLGS	IE
EPxCS	IP
EPxFIFOFLGS	INT2CLR
EPxBCH:L	INT4CLR
EPxFIFOBCH:L	EIE
EPxFIFOBUF	EXIF
REVCTL (bits 0 and 1 <i>must</i> be initialized to '1' for operation as described in this chapter)	

9.3.1 Firmware FIFO Access

EZ-USB firmware can access the slave FIFOs using four registers in XDATA memory: EP2FIFOBUF, EP4FIFOBUF, EP6FIFOBUF, and EP8FIFOBUF. These registers can be read and written directly (using the MOVX instruction), or they can serve as sources and destinations for the dual

Autopointer mechanism built into the EZ-USB (see section [Autopointers on page 96](#)).

Additionally, there are a number of FIFO control and status registers: Byte Count registers indicate the number of bytes in each FIFO; flag bits indicate FIFO fullness, mode bits control the various FIFO modes, etc.

This chapter focuses on the registers and bits which are specific to slave-FIFO operation; for a more detailed description of all the FIFO registers, see the chapters [Access to Endpoint Buffers, on page 87](#) and [Registers, on page 211](#)

Note Setting the REVCTL bits enables features that are not required by every application. So although not necessary, for proper operation as described in this chapter, EZ-USB firmware must set the DYN_OUT and ENH_PKT bits (REVCTL.0 and REVCTL.1) to '1'.

Figure 9-25. EPxFIFOBUF Registers

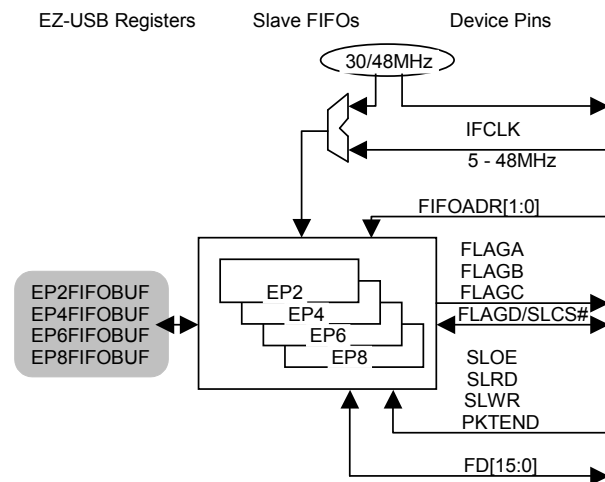

9.3.2 EPx Memories

The slave FIFOs connect external logic to the EZ-USB's four endpoint memories (EP2, EP4, EP6, and EP8). These endpoint memories have the following programmable features:

1. Type can be either BULK, INTERRUPT, or ISOCHRONOUS.
2. Direction can be either IN or OUT.
3. For EP2 and EP6, size can be either 512 or 1024 bytes. EP4 and EP8 are fixed at 512 bytes.
4. Buffering can be 2x, 3x, or 4x for EP2 and EP6. EP4 and EP8 are fixed at 2x.
5. EZ-USB can automatically commit endpoint data to and from the slave FIFO interface (AUTOIN = 1, AUTOOUT = 1), or manually commit endpoint data to and from the slave FIFO interface (AUTOIN = 0, AUTOOUT = 0).

On a hard reset, these endpoint memories are configured as follows:

1. EP2 - Bulk OUT, 512 bytes/packet, 2x buffered.
2. EP4 - Bulk OUT, 512 bytes/packet, 2x buffered.
3. EP6 - Bulk IN, 512 bytes/packet, 2x buffered.
4. EP8 - Bulk IN, 512 bytes/packet, 2x buffered.

Note In full speed mode, buffer sizes scale down to 64 bytes for the non-isochronous types.

Figure 9-26. EPx Memories

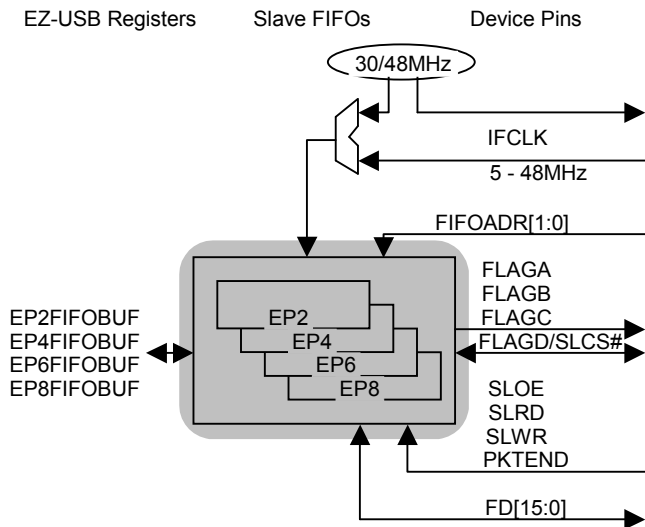

9.3.3 Slave FIFO Programmable Level Flag

Each FIFO's Programmable level Flag (PF) asserts when the FIFO reaches a user-defined fullness threshold.

See the discussion of the EPxFIFOPFH:L registers in the [Registers chapter on page 211](#) for full details.

9.3.4 Auto-In / Auto-Out Modes

The EZ-USB FIFOs can be configured to commit packets to/from USB automatically. For IN endpoints, Auto-In Mode allows the external logic to stream data into a FIFO continuously, with no need for it or the EZ-USB firmware to packetize the data or explicitly signal the EZ-USB to send it to the host. For OUT endpoints, Auto-Out Mode allows the host to continuously fill a FIFO, with no need for the external logic or EZ-USB firmware to handshake each incoming packet, arm the endpoint buffers, and so on. See [Figure 9-27](#).

Figure 9-27. When AUTOOUT=1, OUT Packets are Automatically Committed

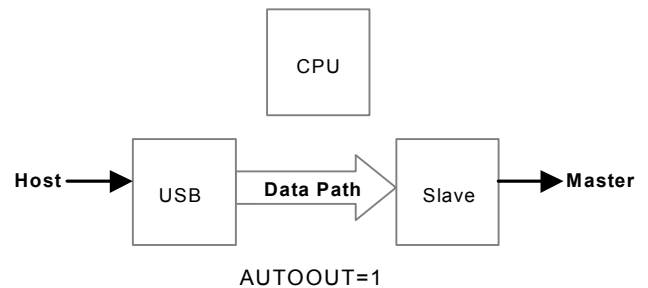

To configure an IN endpoint FIFO for Auto Mode, set the AUTOIN bit in the appropriate EPxFIFOCFG register to '1'. To configure an OUT endpoint FIFO for Auto Mode, set the AUTOOUT bit in the appropriate EPxFIFOCFG register to '1'. See [Figure 9-28](#) and [Figure 9-29 on page 112](#).

On a hard reset, all FIFOs default to Manual Mode (i.e., AUTOIN = 0 and AUTOOUT = 0).

Figure 9-28. TD_Init Example: Configuring AUTOOUT = 1

```

TD_Init() :
... ..
REVCTL = 0x03;          // REVCTL.0 and REVCTL.1 to set to 1
SYNCDELAY;
EP2CFG = 0xA2;         // EP2 is DIR=OUT, TYPE=BULK, SIZE=512, BUF=2x
SYNCDELAY;
FIFORESET = 0x80;     // Reset the FIFO
SYNCDELAY;
FIFORESET = 0x82;
SYNCDELAY;
FIFORESET = 0x00;
SYNCDELAY;
OUTPKTEND = 0x82;     // Arm both EP2 buffers to "prime the pump"
SYNCDELAY;
OUTPKTEND = 0x82;
SYNCDELAY;
EP2FIFOCFG = 0x10;    // EP2 is AUTOOUT=1, AUTOIN=0, ZEROLEN=0, WORDWIDE=0
... ..

```

Figure 9-29. TD_Init Example: Configuring AUTOIN = 1

```

TD_Init() :
... ..
REVCTL = 0x03;          // REVCTL.0 and REVCTL.1 set to 1
SYNCDELAY;
EP8CFG = 0xE0;         // EP8 is DIR=IN, TYPE=BULK
SYNCDELAY;
FIFORESET = 0x80;     // Reset the FIFO
SYNCDELAY;
FIFORESET = 0x88;
SYNCDELAY;
FIFORESET = 0x00;
SYNCDELAY;
EP8FIFOCFG = 0x0C;    // EP8 is AUTOOUT=0, AUTOIN=1, ZEROLEN=1, WORDWIDE=0
SYNCDELAY;
EP8AUTOINLENH = 0x02; // Auto-commit 512-byte packets
SYNCDELAY;
EP8AUTOINLENL = 0x00;
... ..

```

9.3.5 CPU Access to OUT Packets, AUTOOUT = 1

The EZ-USB's CPU is not in the host-to-master data path when AUTOOUT = 1. To achieve the maximum bandwidth, the host and master are directly connected, bypassing the CPU. Figure 9-30 shows that, in Auto-Out mode, data from the host is automatically committed to the FIFOs with no firmware intervention.

Figure 9-30. TD_Poll Example: No Code Necessary for OUT Packets When AUTOOUT=1

```

TD_Poll() :
... ..
// no code necessary to xfr data from host to master!
// AUTOOUT=1 auto-commits packets
... ..

```

Note If AUTOOUT = 1, an OUT FIFO buffer is automatically committed, and could contain 0-1024 bytes, depending on the size of the OUT packet transmitted by the host. The buffer size should be set appropriately (512 or 1024) to accommodate the USB data payload size.

9.3.6 CPU Access to OUT Packets, AUTOOUT = 0

In some systems, it may be desirable to allow the EZ-USB's CPU to participate in the transfer of data between the host and the slave FIFOs. To configure a FIFO for this 'Manual-Out' mode, the AUTOOUT bit in the appropriate EPxFOCFG register must be cleared to '0' (see [Figure 9-31](#)).

Figure 9-31. TD_Init Example, Configuring AUTOOUT=0

```

TD_Init():
... ..
REVCTL = 0x03;          // REVCTL.0 and REVCTL.1 set to 1
SYNCDELAY;
EP2CFG = 0xA2;         // EP2 is DIR=OUT, TYPE=BULK, SIZE=512, BUF=2x
SYNCDELAY;
FIFORESET = 0x80;      // Reset the FIFO
SYNCDELAY;
FIFORESET = 0x82;
SYNCDELAY;
FIFORESET = 0x00;
SYNCDELAY;
EP2FIFOCFG = 0x00;    // EP2 is AUTOOUT=0, AUTOIN=0, ZEROLEN=0, WORDWIDE=0
SYNCDELAY;
OUTPKTEND = 0x82;     // Arm both EP2 buffers to "prime the pump"
SYNCDELAY;
OUTPKTEND = 0x82;
... ..
    
```

As illustrated in [Figure 9-32](#), EZ-USB firmware can do one of three things when the EZ-USB is in Manual-Out mode and a packet is received from the host:

1. It can 'commit' (pass to the FIFOs) the packet by writing OUTPKTEND with SKIP=0 ([Figure 9-33 on page 113](#)).
2. It can 'skip' (discard) the packet by writing OUTPKTEND with SKIP=1 ([Figure 9-34 on page 114](#)).
3. It can 'edit' the packet (or source an entire OUT packet) by writing to the FIFO buffer directly, then write the length of the packet to EPxBCH:L. The write to EPxBCL commits the edited packet, so EPxBCL should be written after writing EPxBCH ([Figure 9-35 on page 114](#)).

In all cases, the OUT buffer automatically re-arms so it can receive the next packet, once the external master has finished reading all data in the OUT buffer.

See section [8.6.2.4 EP2BCH:L, EP4BCH:L, EP6BCH:L, EP8BCH:L on page 93](#) for a detailed description of the SKIP bit.

Figure 9-32. Skip, Commit, or Source (AUTOOUT=0)

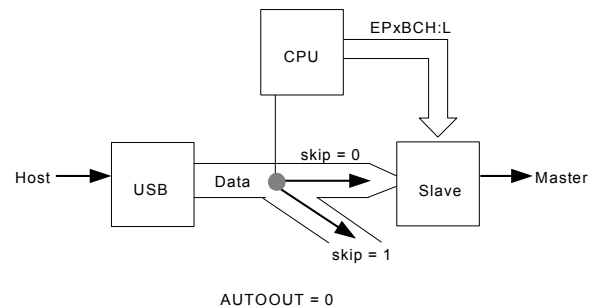

Figure 9-33. TD_Poll Example, AUTOOUT=0, Commit Packet

```

TD_Poll():
... ..
if( !( EP2468STAT & 0x01 ) )
{ // EP2EF=0 when FIFO NOT empty, host sent packet
  OUTPKTEND = 0x02; // SKIP=0, pass buffer on to master
}
... ..
    
```

Figure 9-34. sbTD_Poll Example, AUTOOUT=0, Skip Packet

```

TD_Poll() :
... ..
if( !( EP2468STAT & 0x01 ) )
{ // EP2EF=0 when FIFO NOT empty, host sent packet
  OUTPKTEND = 0x82; // SKIP=1, do NOT pass buffer on to master
}
... ..

```

Figure 9-35. TD_Poll Example, AUTOOUT=0, Source

```

TD_Poll() :
... ..
if( EP24FIFOFLGS & 0x02 )
{
  SYNCDELAY; //
  FIFORESET = 0x80; // nak all OUT pkts. from host
  SYNCDELAY; //
  FIFORESET = 0x82; // advance all EP2 buffers to cpu domain
  SYNCDELAY; //
  EP2FIFOBUF[0] = 0xAA; // create newly sourced pkt. data
  SYNCDELAY; //
  EP2BCH = 0x00;
  SYNCDELAY; //
  EP2BCL = 0x01; // commit newly sourced pkt. to interface fifo

  // beware of "left over" uncommitted buffers

  SYNCDELAY; //
  OUTPKTEND = 0x82; // skip uncommitted pkt. (second pkt.)
  // note: core does not allow pkts. to get out of sequence
  SYNCDELAY; //
  FIFORESET = 0x00; // release "nak all"
}
... ..

```

Note If an uncommitted packet is in an OUT endpoint buffer when the EZ-USB is reset, that packet is not automatically committed to the master. To ensure that no uncommitted packets are in the endpoint buffers after a reset, the EZ-USB firmware’s ‘endpoint initialization’ routine should skip 2, 3, or 4 packets (depending on the buffering depth selected for the FIFO) by writing OUTPKTEND with SKIP=1. See [Figure 9-36](#).

Figure 9-36. TD_Init Example, OUT Endpoint Initialization

```

TD_Init() :
... ..
REVCTL = 0x03; // REVCTL.0 and REVCTL.1 set to 1
SYNCDELAY;
EP2CFG = 0xA2; // EP2 is DIR=OUT, TYPE=BULK, SIZE=512, BUF=2x
SYNCDELAY;
EP2FIFOCFG = 0x00; // EP2 is AUTOOUT=0, AUTOIN=0, ZEROLEN=0, WORDWIDE=0

// OUT endpoints do NOT come up armed
SYNCDELAY;
OUTPKTEND = 0x82; // arm first buffer by writing OUTPKTEND w/skip=1
SYNCDELAY;
OUTPKTEND = 0x82; // arm second buffer by writing OUTPKTEND w/skip=1
... ..

```

9.3.7 CPU Access to IN Packets, AUTOIN = 1

Auto-In mode is similar to Auto-Out mode: When an IN FIFO is configured for Auto-In mode (by setting its AUTOIN bit to '1'), data from the master is automatically packetized and committed to USB without any CPU intervention (see Figure 9-37).

Figure 9-37. TD_Poll Example, AUTOIN = 1

```

TD_Poll() :
... ..
// no code necessary to xfr data from master to host!
// AUTOIN=1 and EP8AUTOINLEN=512 auto commits packets
// in 512 byte chunks.
... ..

```

Auto-In mode differs in one important way from Auto-Out mode: In Auto-Out mode, data (excluding data in short packets) is always auto-committed in 512- or 1024-byte packets; in Auto-In mode, the auto-commit packet size may be set to any non-zero value (with the single restriction, of course, that the packet size must be less than or equal to the size of the endpoint buffer). Each FIFO's Auto-In packet size is stored in its EPxAUTOINLENH:L register pair.

To source an IN packet, EZ-USB firmware can temporarily halt the flow of data from the external master (via a signal on a general-purpose I/O pin, typically), wait for an endpoint buffer to become available, create a new packet by writing directly to that buffer, then commit the packet to USB and release the external master. In this way, the firmware can insert its own packets in the data stream. See Figure 9-38, which illustrates data flowing directly between the master and the host, and Figure 9-39, which shows the firmware sourcing an IN packet. A firmware example appears in Figure 9-40 on page 116.

Figure 9-38. Master Writes Directly to Host, AUTOIN = 1

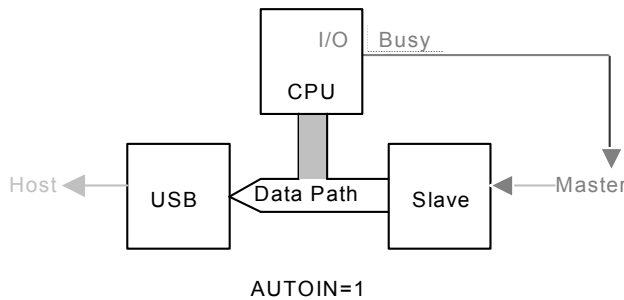

Figure 9-39. Firmware Intervention, AUTOIN = 0 or 1

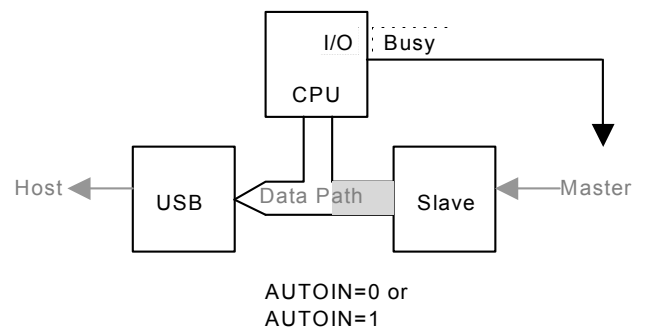

Figure 9-40. TD_Poll Example: Sourcing an IN Packet

```

TD_Poll() :
... ..
if( source_pkt_event )
{ // 100-msec background timer fired
  if( holdoff_master( ) )
  { // signaled "busy" to master successful
    while( !( EP68FIFOFLGS & 0x20 ) )
    { // EP8EF=0, when buffer not empty
      ; // wait 'til host takes entire FIFO data
    }

    FIFORESET = 0x80; // initiate the "source packet" sequence
    SYNCDELAY;
    FIFORESET = 0x88;
    SYNCDELAY;
    FIFORESET = 0x00;

    EP8FIFOBUF[ 0 ] = 0x02; // <STX>, packet start of text msg
    EP8FIFOBUF[ 1 ] = 0x06; // <ACK>
    EP8FIFOBUF[ 2 ] = 0x07; // <HEARTBEAT>
    EP8FIFOBUF[ 3 ] = 0x03; // <ETX>, packet end of text msg

    SYNCDELAY;
    EP8BCH = 0x00;
    SYNCDELAY;
    EP8BCL = 0x04; // pass newly-sourced buffer on to host
  }
  else
  {
    history_record( EP8, BAD_MASTER );
  }
}
... ..

```

9.3.8 Access to IN Packets, AUTOIN=0

In some systems, it may be desirable to allow the EZ-USB's CPU to participate in every data-transfer between the external master and the host. To configure a FIFO for this 'Manual-In' mode, the AUTOIN bit in the appropriate EPxFIFOCFG register must be cleared to '0'.

In Manual-In mode, EZ-USB firmware can commit, skip, or edit packets sent by the external master, and it may also source packets directly. To commit a packet, firmware writes the endpoint number (with SKIP=0) to the INPKTEND register. To skip a packet, firmware writes the endpoint number with SKIP=1 to the INPKTEND register. To edit or source a packet, firmware writes to the FIFO buffer, then writes the packet commit length to EPxBCH and EPxBCL (in that order).

Figure 9-41. TD_Poll, AUTOIN=0, Committing a Packet via INPKTEND

```

TD_Poll() :
... ..
if( master_finished_longxfr( ) )
{ // master currently points to EP8, pins FIFOADR[1:0]=11
  if( !( EP68FIFOFLGS & 0x10 ) )
  { // EP8FF=0 when buffer available
    INPKTEND = 0x08; // firmware commits EP8 packet
    // by writing 8 to INPKTEND
    release_master( EP8 );
  }
}
... ..

```

Figure 9-42. TD_Poll, AUTOIN=0, Skipping a Packet via INPKTEND

```

TD_Poll() :
... ..
if( master_finished_longxfr() )
{ // master currently points to EP8, pins FIFOADR[1:0]=11
  if( !( EP68FIFOFLGS & 0x10 ) )
  { // EP8FF=0 when buffer available
    INPKTEND = 0x88; // firmware skips EP8 packet
                    // by writing 0x88 to INPKTEND
    release_master( EP8 );
  }
}
... ..

```

Figure 9-43. TD_Poll, AUTOIN=0, Editing a Packet via EPxBCH:L

```

TD_Poll() :
... ..
if( master_finished_xfr() )
{ // modify the data
  EP8FIFOBUF[ 0 ] = 0x02; // <STX>, packet start of text msg
  EP8FIFOBUF[ 7 ] = 0x03; // <ETX>, packet end of text msg
  SYNCDELAY;
  EP8BCH = 0x00;
  SYNCDELAY;
  EP8BCL = 0x08; // pass buffer on to host, packet size is 8
}
... ..

```

9.3.9 Auto In/Auto Out Initialization

6. Arm OUT buffers by writing to OUTPKTEND N times with skip = 1, where N is buffering depth.
7. Set bit EPxFIFOCFG.4=1.

Enabling Auto In transfers between slave FIFO and endpoint

Typically, a FIFO is configured for Auto-In mode as follows:

1. Configure bits IFCONFIG[7:4] to define the behavior of the interface clock.
2. Set bits IFCFG1:0=11.
3. Set REVCTL.0 and REVCTL.1 to '1'.
4. Configure EPxCFG.
5. Reset the FIFOs.
6. Set bit EPxFIFOCFG.3=1.
7. Set the size through the EPxAUTOINLENH:L registers.

Enabling Auto Out transfers between endpoint and slave FIFO

Typically, a FIFO is configured for Auto-Out mode as follows:

1. Configure bits IFCONFIG[7:4] to define the behavior of the interface clock.
2. Set bits IFCFG1:0=11.
3. Set REVCTL.0 and REVCTL.1 to '1'.
4. Configure EPxCFG.
5. Reset the FIFOs.

9.3.10 Auto Mode: Synchronous FIFO IN Data Transfers

Figure 9-44. Code Example, Synchronous Slave FIFO IN Data Transfer

```

TD_Init():
IFCONFIG = 0x03;      // use IFCLK pin driven by external logic (5MHz to 48MHz)
                      // use slave FIFO interface pins driven sync by external master
SYNCDELAY;
REVCTL = 0x03;       // REVCTL.0 and REVCTL.1 set to 1
SYNCDELAY;
EP8CFG = 0xE0;       // sets EP8 valid for IN's
                      // and defines the endpoint for 512 byte packets, 2x buffered
SYNCDELAY;
FIFORESET = 0x80;    // reset all FIFOs
SYNCDELAY;
FIFORESET = 0x82;
SYNCDELAY;
FIFORESET = 0x84;
SYNCDELAY;
FIFORESET = 0x86;
SYNCDELAY;
FIFORESET = 0x88;
SYNCDELAY;
FIFORESET = 0x00;
SYNCDELAY;
EP8FIFOCFG = 0x0C;   // this defines the external interface to be the following:
                      // this lets the EZ-USB auto commit IN packets, gives the
                      // ability to send zero length packets,
                      // and sets the slave FIFO data interface to 8-bits

PINFLAGSAB = 0x00;   // defines FLAGA as prog-level flag, pointed to by FIFOADR[1:0]
SYNCDELAY;
PINFLAGSCD = 0x00;   // FLAGB as full flag, as pointed to by FIFOADR[1:0]
                      // FLAGC as empty flag, as pointed to by FIFOADR[1:0]
                      // won't generally need FLAGD

PORTACFG = 0x00;     // used PA7/FLAGD as a port pin, not as a FIFO flag
SYNCDELAY;
FIFOPINPOLAR = 0x00; // set all slave FIFO interface pins as active low
SYNCDELAY;
EP8AUTOINLENH = 0x02; // EZ-USB automatically commits data in 512-byte chunks
SYNCDELAY;
EP8AUTOINLENL = 0x00;

SYNCDELAY;
EP8FIFOPFH = 0x80;   // you can define the programmable flag (FLAGA)
SYNCDELAY;
EP8FIFOPFL = 0x00;   // to be active at the level you wish

TD_Poll():
// nothing! The EZ-USB is doing all the work of transferring packets
// from the external master sync interface to the endpoint buffer...

```

9.3.11 Auto Mode Example: Asynchronous FIFO IN Data Transfers

The initialization code is exactly the same as for the synchronous-transfer example in [Auto Mode: Synchronous FIFO IN Data Transfers on page 118](#), but with IFCLK configured for internal use at a rate of 48 MHz and the ASYNC bit set to '1'. [Figure 9-45](#) shows the one-line modification that is needed.

Figure 9-45. TD_Init Example, Asynchronous Slave FIFO IN Data Transfers

```
TD_Init ( ): // slight modification from our synchronous firmware example
IFCONFIG = 0xCB;
// this defines the external interface as follows:
// use internal IFCLK (48MHz)
// use slave FIFO interface pins asynchronously to external master
```

Code to perform the transfers is, as before, unnecessary; as [Figure 9-46](#) illustrates.

Figure 9-46. TD_Poll Example, Asynchronous Slave FIFO IN Data Transfers

```
TD_Poll ( ):
// nothing! The EZ-USB is doing all the work of transferring packets
// from the external master async interface to the endpoint buffer...
```

9.3.12 Skipping Out Packets while in AUTOOUT Mode

If flushing the packets in the buffers is required, It is necessary to switch from auto mode to manual mode and reset the FIFO. In auto out mode, if the firmware needs to flush the packets received from host that are not read by the external master/slave, the firmware can implement this sequence:

1. Set the NAKALL bit
2. Switch to manual mode

3. Reset the FIFOs
4. Use OUTPKTEND 'n' times to skip uncommitted packets (FIFO is 'n' buffered)
5. Switch to auto mode
6. Release the NAKALL bit

Note Resetting the FIFO while it is configured as AUTOOUT does not clear the buffer or set the EMPTY bit in EPxCS. This is why OUTPKTEND is used 'n' times for 'n' buffered FIFO.

Figure 9-47. TD_Poll Example, Skipping Out Packets in AUTOOUT Mode

```
TD_Poll ( ) :
... ..
if (FIFO_RESET)
{
//This is an example code segment which resets the EP2 FIFO
//where EP2 has been configured as AUTOOUT
//Note: Settings of other bits of EPxFIFOCFG are ignored here

FIFORESET = 0x80; // activate NAK-ALL to avoid race conditions
SYNCDELAY;
EP2FIFOCFG = 0x00; //switching to manual mode
SYNCDELAY;
FIFORESET = 0x02; // Reset FIFO 2
SYNCDELAY;
OUTPKTEND = 0x82; //OUTPKTEND done twice as EP2 is double buffered by default
SYNCDELAY;
OUTPKTEND = 0x82;
SYNCDELAY;
EP2FIFOCFG = 0x10; //switching to auto mode
SYNCDELAY;
FIFORESET = 0x00; //Release NAKALL
SYNCDELAY;
}
... ..
```

9.3.13 Aborting Packets in FIFO while in AUTOIN Mode

Resetting the FIFO, after taking it out of the AUTOIN mode, empties the FIFO and sets the EMPTY bit in EPxCS. Any packets in the buffers are skipped or invalid. Thus the sequence is:

1. Set the NAKALL bit
2. Switch to manual mode
3. Reset the FIFOs
4. Switch to auto mode
5. Release the NAKALL bit

Figure 9-48. TD_Poll Example, Aborting Packets in FIFO while in AUTOIN Mode

```

TD_Poll ( ) :
... ..
if (FIFO_RESET)
{
//This is an example code segment which resets the EP6 FIFO
//where EP6 has been configured as AUTOIN
//Note: Settings of other bits of EPxFIFOCFG are ignored here

FIFORESET = 0x80; // activate NAK-ALL to avoid race conditions
SYNCDELAY;
EP6FIFOCFG = 0x00; //switching to manual mode
SYNCDELAY;
FIFORESET = 0x06; // Reset FIFO 6
SYNCDELAY;
EP6FIFOCFG = 0x0C; //switching to auto mode
SYNCDELAY;
FIFORESET = 0x00; //Release NAKALL
SYNCDELAY;
}
... ..

```

9.4 Switching Between Manual Out and Auto Out

Because OUT endpoints are not automatically armed when the EZ-USB enters Auto-Out mode, the firmware can safely switch the EZ-USB between Manual-Out and Auto-Out modes without any need to flush or reset the FIFOs.

Note Switching between Manual-Out mode to Auto-Out mode is not required for every application. Most applications remain in either mode for each endpoint.

10. General Programmable Interface



10.1 Introduction

The General Programmable Interface (GPIF) is an internal master to the EZ-USB's endpoint FIFOs. It replaces the external 'glue' logic which might otherwise be required to build an interface between the EZ-USB and the outside world.

At the GPIF's core is a programmable state machine which generates up to six 'control' and nine 'address' outputs, and accepts six external and two internal 'ready' inputs. Four user defined Waveform Descriptors control the state machine; generally (but not necessarily), one is written for FIFO reads, one for FIFO writes, one for single-byte/word reads, and one for single-byte/word writes.

Note Read and Write are from the EZ-USB's point of view. 'Read' waveforms transfer data from the outside world to the EZ-USB; 'Write' waveforms transfer data from the EZ-USB to the outside world.

EZ-USB firmware can assign the FIFO read and FIFO write waveforms to any of the four FIFOs, and the GPIF generates the proper strobes and handshake signals to the outside-world interface as data is transferred into or out of that FIFO.

As with external mastering (see [Slave FIFOs, on page 99](#)), the data bus between the FIFOs and the outside world can be either 8 or 16 bits wide.

The GPIF is not limited to simple handshaking interfaces between the EZ-USB and external ASICs or microprocessors; it is powerful enough to directly implement such protocols as ATAPI (PIO and UDMA), IEEE 1284 (EPP Parallel Port), Utopia, and others. An EZ-USB can, for instance, function as a single-chip interface between USB and an IDE hard disk drive or CompactFlash™ memory card.

This chapter provides an overview of GPIF, discusses external connections, and explains the operation of the GPIF engine. [Figure 10-1 on page 122](#) presents a block diagram illustrating GPIF's place in the EZ-USB system.

Note GPIF waveforms are created with the Cypress GPIF Designer utility, a Windows®-based application which is distributed with the Cypress EZ-USB Development Kit. Although this chapter describes the structure of the Waveform Descriptors in some detail, knowledge of that structure is usually not necessary. The GPIF Designer simply hides the complexity of the Waveform Descriptors; it does not compromise the programmer's control over the GPIF in any way.

Figure 10-1. GPIF's Place in the EZ-USB System

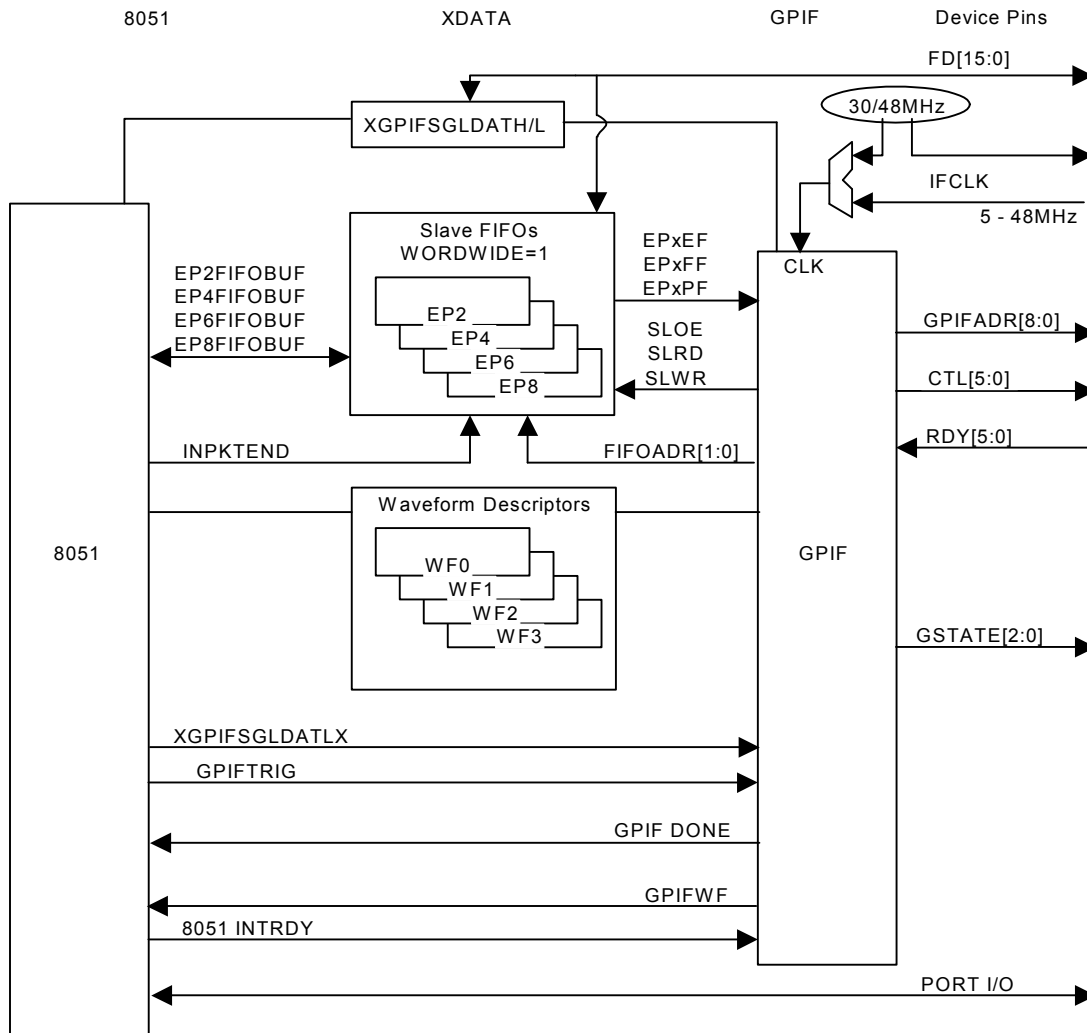
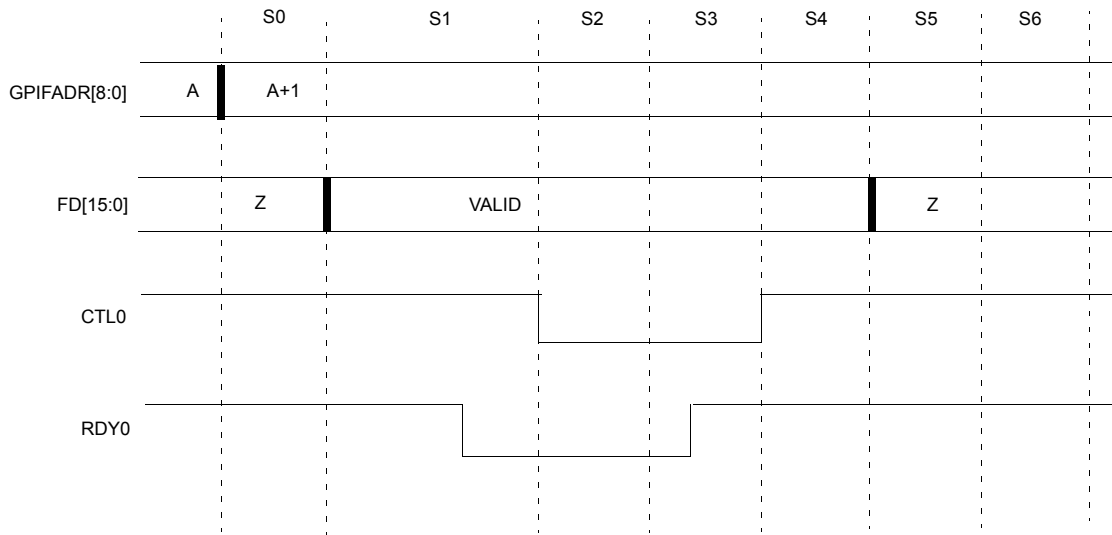

Figure 10-2 on page 123 shows an example of a simple GPIF transaction. For this transaction, the GPIF generates an address (GPIFADR[8:0]), drives the FIFO data bus (FD[15:0]), then waits for an externally-supplied handshake signal (RDY0) to go low, after which it pulls its CTL0 output low. When the RDY0 signal returns high, the GPIF brings its CTL0 output high, then floats the data bus.

Figure 10-2. Example GPIF Waveform



10.1.1 Typical GPIF Interface

The GPIF allows the EZ-USB to connect directly to external peripherals such as ASICs, DSPs, or other digital logic that uses an 8 or 16 bit parallel interface.

The GPIF provides external pins that can operate as outputs (CTL[5:0]), inputs (RDY[5:0]), Data bus (FD[15:0]), and Address Lines (GPIFADR[8:0]).

A Waveform Descriptor in internal RAM describes the behavior of each of the GPIF signals. The Waveform Descriptor is loaded into the GPIF registers by the EZ-USB firmware during initialization, and it is then used throughout the execution of the code to perform transactions over the GPIF interface.

Figure 10-3 shows a block diagram of a typical interface between the EZ-USB and a peripheral function.

Figure 10-3. EZ-USB Interfacing to a Peripheral

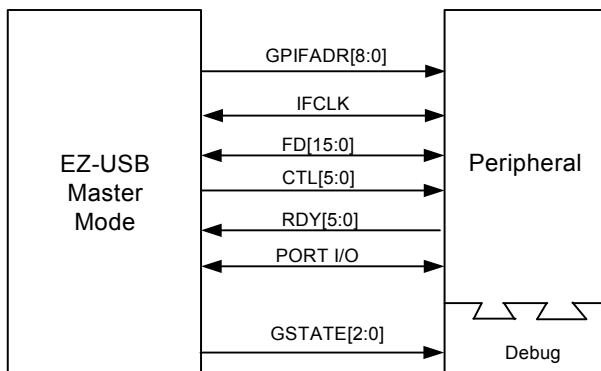

The following sections detail the features available and steps needed to create an efficient GPIF design. This includes definition of the external GPIF connections and the internal register settings, along with EZ-USB firmware needed to execute data transactions over the interface.

10.2 Hardware

Table 10-1 lists the registers associated with the GPIF hardware; a detailed description of each register may be found in the Registers chapter on page 211.

Table 10-1. Registers Associated with GPIF Hardware

Register Name	
GPIFIDLECS	IFCONFIG
GPIFIDLECTL	FIFORESET
GPIFCTLCFG	EPxCFG
PORTCCFG	EPxFIFOCFG
PORTECFG	EPxAUTOINLENH/L
GPIFADRH/L	EPxFIFOPFH/L
GPIFTCB3:0	
GPIFWFSELECT	EPxGPIFTRIG
EPxGPIFFLGSEL	GPIFABORT
EPxGPIFPFSTOP	XGPIFGLDATH/LX/LNOX
GPIFREADYCFG	GPIFGLDATH/LX/LNOX
GPIFREADYSTAT	GPIFTRIG

Note The 'x' in these register names represents 2, 4, 6, or 8; endpoints 0 and 1 are not associated with the GPIF.

10.2.1 The External GPIF Interface

The GPIF provides many general input and output signals with which external peripherals may be interfaced ‘gluelessly’ to the EZ-USB.

The GPIF interface signals are shown in [Table 10-2](#).

Table 10-2. GPIF Pin Descriptions

PIN	IN/OUT	Description
CTL[5:0]	O / Hi-Z	Programmable control outputs
RDY[5:0]	I	Sampleable ready inputs
FD[15:0]	I / O / Hi-Z	Bidirectional FIFO data bus
GPIFADR[8:0]	O / Hi-Z	Address outputs
IFCLK	I / O	Interface clock
GSTATE[2:0]	O / Hi-Z	Current GPIF State number (for debug)

The Control Output pins (CTL[5:0]) are usually used as strobes (enable lines), read/write lines, and others.

The Ready Input pins (RDY[5:0]) are sampled by the GPIF and can force a transaction to wait (inserting wait states), continue, or repeat until they are in a particular state.

The GPIF Data Bus is a collection of the FD[15:0] pins.

- An 8 bit wide GPIF interface uses pins FD[7:0].
- A 16 bit wide GPIF interface uses pins FD[15:0].

The GPIF Address lines (GPIFADR[8:0]) can generate an incrementing address as data is transferred. If higher order address lines are needed, other non-GPIF I/O signals (for example, general-purpose I/O pins) may be used.

The Interface Clock, IFCLK, can be configured to be either an input (default) or an output interface clock for synchronous interfaces to external logic.

The GSTATE[2:0] pins are outputs that show the current GPIF State number; they are used for debugging GPIF waveforms.

The number of GPIF signals available externally varies depending on the package. See package information in [Introducing EZ-USB® chapter on page 13](#).

10.2.2 Default GPIF Pins Configuration

The EZ-USB comes out of reset with its I/O pins configured in Ports mode, not GPIF Master mode. To configure the pins for GPIF mode, the IFCFG1:0 bits in the IFCONFIG register must be set to ‘10’ (see [Table 13-10, “IFCFG Selection of Port I/O Pin Functions,” on page 188](#) for details).

10.2.3 Six Control OUT Signals

The 100 and 128-pin EZ-USB packages bring out all six Control Output pins, CTL[5:0]. The 56-pin package brings out three of these signals, CTL[2:0]. CTLx waveform edges can be programmed to make transitions as often as once

per IFCLK clock (once every 20.8 ns if IFCLK is running at 48 MHz).

By default, these signals are driven high.

10.2.3.1 Control Output Modes

The GPIF Control pins (CTL[5:0]) have several output modes:

- CTL[3:0] can act as CMOS outputs (optionally tristatable) or open drain outputs.
- CTL[5:4] can act as CMOS outputs or open-drain outputs.
If CTL[3:0] are configured to be tristatable, CTL[5:4] are not available.

Table 10-3. CTL[5:0] Output Modes

TRICTL (GPIFCTLCFG.7)	GPIFCTLCFG[6:0]	CTL[3:0]	CTL[5:4]
0	0	CMOS, Not Tri-statable	CMOS, Not Tri-statable
0	1	Open-Drain	Open-Drain
1	X	CMOS, Tri-statable	Not Available

10.2.4 Six Ready IN Signals

The 100 and 128-pin EZ-USB packages bring out all six Ready inputs, RDY[5:0]. The 56-pin package brings out two of these signals, RDY[1:0].

The RDY inputs can be sampled synchronously or asynchronously. When the GPIF samples RDY inputs asynchronously (SAS = 0), the RDY inputs are unavoidably delayed by a small amount (approximately 24 ns at 48 MHz IFCLK). In other words, when the GPIF ‘looks’ at a RDY input, it actually ‘sees’ the state of that input 24 ns ago.

10.2.5 Nine GPIF Address OUT Signals

Nine GPIF address lines, GPIFADR[8:0], are available. If the GPIF address lines are configured as outputs, writing to the GPIFADRH:L registers drives these pins immediately. The GPIF engine can then increment them under control of the Waveform Descriptors. The GPIF address lines can be tristated by clearing the associated PORTxCFG bits and OEx bits to ‘0’ (see [section 13.4.3 Port C Alternate Functions on page 187](#) and [section 13.4.4 Port E Alternate Functions on page 188](#)).

10.2.6 Three GSTATE OUT Signals

Three GPIF State lines, GSTATE[2:0], are available as an alternate configuration of PORTE[2:0]. These default to general-purpose inputs; setting GSTATE (IFCONFIG.2) to ‘1’ selects the alternate configuration and overrides PORTECFG[2:0] bit settings.

The GSTATE[2:0] pins output the current GPIF State number; this feature is used for debugging GPIF waveforms, and is useful for correlating intended GPIF waveform behavior with actual observed GPIF signaling.

10.2.7 8/16-Bit Data Path, WORDWIDE = 1 (default) and WORDWIDE = 0

When the EZ-USB is configured for GPIF Master mode, PORTB is always configured as FD[7:0].

If any of the WORDWIDE bits (EPxFIFOCFG.0) are set to '1', PORTD is automatically configured as FD[15:8]. If all the WORDWIDE bits are cleared to '0', PORTD is available for general-purpose I/O.

10.2.8 Byte Order for 16 Bit GPIF Transactions

Data is sent over USB in packets of 8-bit bytes, not 16-bit words. When the FIFO Data bus is 16 bits wide, the first byte in every pair sent over USB is transferred over FD[7:0] and the second byte is transferred over FD[15:8].

10.2.9 Interface Clock (IFCLK)

The GPIF interface can be clocked from either an internal or an external source. The EZ-USB's internal clock source can be configured to run at either 30 or 48 MHz, and it can optionally be output on the IFCLK pin. If the EZ-USB is configured to use an external clock source, the IFCLK pin can be driven at any frequency between 5 MHz and 48 MHz. On a hard reset, the EZ-USB defaults to the internal source at 48 MHz, normal polarity, with the IFCLK output disabled. See [Figure 10-4](#).

IFCONFIG.7 selects between internal and external sources: 0 = external, 1 = internal. If an external IFCLK is chosen, it must be free running at a minimum frequency of 5 MHz. In addition, in order to provide synchronization for the internal endpoint FIFO logic, the external IFCLK source must be present before the firmware sets IFCONFIG.7 = 0.

IFCONFIG.6 selects between the 30 and 48 MHz internal clock: 0 = 30 MHz; 1 = 48 MHz. This bit has no effect when IFCONFIG.7 = 0.

IFCONFIG.5 is the output enable for the internal clock source: 0 = disable; 1 = enable. This bit has no effect when IFCONFIG.7 = 0.

IFCONFIG.4 inverts the polarity of the interface clock (whether it is internal or external): 0 = normal; 1 = inverted. IFCLK inversion can make it easier to interface the EZ-USB with certain external circuitry. When an internal IFCLK is used (IFCONFIG.7 = 1), IFCONFIG.4 only affects the IFCLK output polarity (if IFCONFIG.5 = 1). When an external IFCLK is used (IFCONFIG.7 = 0), IFCONFIG.4 only affects the IFCLK input polarity. [Figure 10-5 on page 126](#), for example, demonstrates the use of IFCLK output inversion in order to ensure a long enough setup time (t_s) for a control signal to the peripheral.

Note When IFCLK is configured as an input, the minimum external frequency that can be applied to it is 5 MHz. This clock must be applied prior to initialization of the GPIF and interruptions of it lowers the overall frequency, causing violations of the minimum frequency requirement.

Figure 10-4. IFCLK Configuration

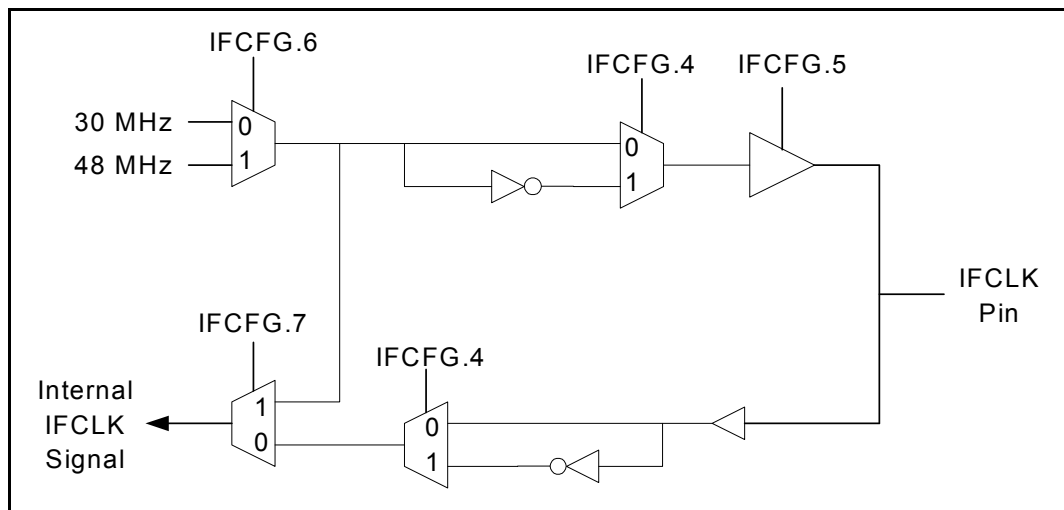
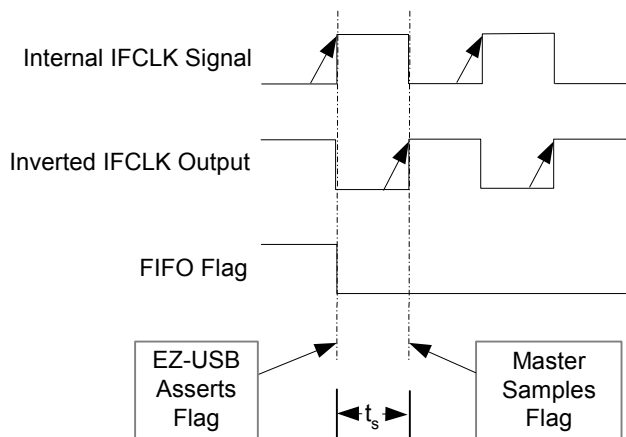

Figure 10-5. Satisfying Setup Timing by Inverting the IFCLK Output



10.2.10 Connecting GPIF Signal Pins to Hardware

The first step in creating the interface between the EZ-USB's GPIF and an external peripheral is to define the hardware interconnects.

1. **Choose IFCLK settings.** Choose either the internal or external interface clock. If internal, choose either 30 or 48 MHz; if external, ensure that the frequency of the external clock is in the range 5-48 MHz, and that it is free running.
2. **Determine the proper FIFO Data Bus size.** If the data bus for the interface is 8 bits wide, use the FD[7:0] pins and set WORDWIDE=0. If the data bus for the interface is 16 bits wide, use FD[15:0] and set WORDWIDE=1.
3. **Assign the CTLx signals to the interface.** Make a list of all interface signals to be driven from the GPIF to the peripheral, and assign them to the CTL[5:0] inputs. If there are more output signals than available CTLx outputs, non-GPIF I/O signals must be driven manually by EZ-USB firmware. In this case, the CTLx outputs should be assigned only to signals that must be driven as part of a data transaction.
4. **Assign the RDYn signals to the interface.** Make a list of all interface signals to be driven from the peripheral to the GPIF, and assign them to the RDY[5:0] inputs. If there are more input signals than available RDY inputs, non-GPIF I/O signals must be sampled manually by EZ-USB firmware. In this case, the RDYn inputs should be used only for signals that must be sampled as part of a data transaction.
5. **Determine the proper GPIF Address connections.** If the interface uses an Address Bus, use the GPIFADR[8:0] signals for the least significant bits, and other non-GPIF I/O signals for the most significant bits. If the address pins are not needed (as when, for instance, the peripheral is a FIFO) they may be left unconnected.

10.2.11 Example GPIF Hardware Interconnect

Table 10-4 illustrates the hardware connections that can be made for a standard interface to a 27C256 EPROM.

The process is the same for larger, more-complicated interfaces.

Note Two other GPIF hardware interconnect examples are also available in the GPIF Designer utility. These examples illustrate a connection between the GPIF and the asynchronous FIFO as well as a connection between the GPIF and a DSP from Texas Instrument.

Table 10-4. Example GPIF Hardware Interconnect

Step	Result	Connection Made
1. Choose IFCLK settings.	Internal IFCLK, 48MHz, Async RDY sampling, GPIF.	No connection.
2. Determine proper FIFO Data Bus size.	8 bits from the EPROM.	FD[7:0] to D[7:0]. Firmware writes WORDWIDE=0.
3. Assign CTLx signals to the interface.	\overline{CS} and \overline{OE} are inputs to the EPROM.	CTL0 to \overline{CS} . CTL1 to \overline{OE} .
4. Assign RDYn signals to the interface.	27C256 EPROM has no output ready/wait signals.	No connection.
5. Determine the proper GPIFADR connections.	16 bits of address.	GPIFADR[8:0] to A[8:0] and other I/O pins to A[15:9].

10.3 Programming the GPIF Waveforms

Each GPIF Waveform Descriptor can define up to seven States. In each State, the GPIF can be programmed to:

- Drive (high or low) or float the CTL outputs
- Sample or drive the FIFO Data bus
- Increment the value on the GPIF Address bus
- Increment the pointer into the current FIFO
- Trigger a GPIFWF (GPIF Waveform) interrupt

Additionally, each State may either sample any two of the following:

- The RDYx input pins
- A FIFO flag
- The INTRDY (internal RDY) flag
- The Transaction-Count-Expired flag

then AND, OR, or XOR the two terms and branch on the result to any State

or:

- Delay a specified number [1-256] of IFCLK cycles

States that sample and branch are called 'Decision Points' (DPs); states that do not are called 'Non-Decision Points' (NDPs).

Figure 10-6. GPIF State Machine Overview

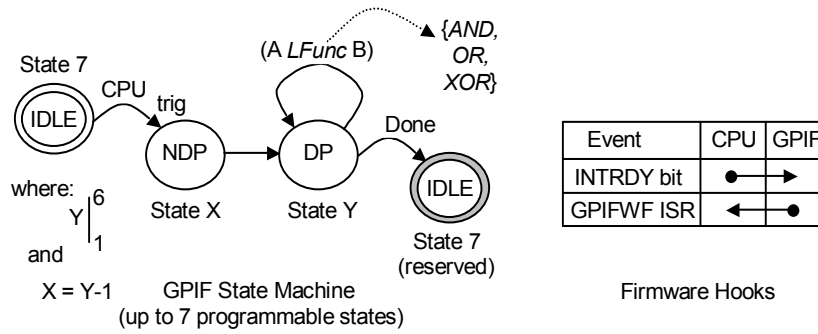

10.3.1 The GPIF Registers

Two blocks of registers control the GPIF state machine:

- **GPIF Configuration Registers** — These registers configure the general settings and report the status of the interface. Refer to the [Registers chapter on page 211](#) and the remainder of this chapter for details.
- **Waveform Registers** — These registers are loaded with the Waveform Descriptors that configure the GPIF state machine; there are a total of 128 bytes located at addresses 0xE400 to 0xE47F. *The GPIF Designer utility should be used to create Waveform Descriptors.*

GPIF transactions cannot be initiated until the Configuration registers and Waveform registers are loaded by EZ-USB firmware.

Access to the Waveform registers is only allowed while the EZ-USB is in GPIF mode (i.e., IFCFG1:0 = 10). The Waveform registers may only be written while the GPIF engine is halted (for example, DONE = 1).

If it is desired to dynamically reconfigure Waveform Descriptors, this may be accomplished by writing just the bytes that change; it is not necessary to reload the entire set of Waveform Descriptors in order to modify only a few bytes.

10.3.2 Programming GPIF Waveforms

The 'programs' for GPIF waveforms are the Waveform Descriptors, which are stored in the Waveform registers by EZ-USB firmware.

The EZ-USB can hold up to four Waveform Descriptors, each of which can be used for one of four types of transfers: Single Write, Single Read, FIFO Write, or FIFO Read. By default, one Waveform Descriptor is assigned to each transfer type, but it is not necessary to retain that configuration; all four Waveform Descriptors could, for instance, be configured for FIFO Write usage (see the GPIFWFSELECT register in the [Registers chapter on page 211](#)).

Each Waveform Descriptor consists of up to seven 32 bit State Instructions that program key transition points for GPIF interface signals. There is a one-to-one correspondence between the State Instructions and the GPIF state machine States. Among other things, each State Instruction defines the state of the CTLx outputs, the state of FD[15:0], the use of the RDYn inputs, and the behavior of GPIFADR[8:0].

Transitions from one State to another always happen on a rising edge of the IFCLK, but the GPIF may remain in one State for many IFCLK cycles.

10.3.2.1 The GPIF IDLE State

A Waveform consists of up to seven programmable States, numbered S0 to S6, and one special Idle State: S7. **Note** A Waveform terminates when the GPIF program branches to its Idle State.

To complete a GPIF transaction, the GPIF program must branch to the IDLE State, regardless of the State that the GPIF program is currently executing. For example, a GPIF Waveform might be defined by a program which contains only two programmed States, S0 and S1. The GPIF program would branch from S1 (or S0) to S7 when it wished to terminate.

The state of the GPIF signals during the Idle State is determined by the contents of the GPIFIDLECS and GPIFIDLECTL registers.

Once a waveform is triggered, another waveform may not be started until the first one terminates. Termination of a waveform is signaled through the DONE bit (GPIFIDLECS.7 or GPIFTRIG.7) or, optionally, through the GPIFDONE interrupt.

- If DONE = 0, the GPIF is busy generating a Waveform.
- If DONE = 1, the GPIF is done (GPIF is in the Idle State) and ready for firmware to start the next GPIF transaction.

Note With one exception (writing to the GPIFABORT register in order to force the current waveform to terminate) it is illegal to write to any of the GPIF-related registers (including the Waveform Registers) while the GPIF is busy. Doing so causes indeterminate behavior likely to result in data corruption.

GPIF Data Bus During IDLE

During the Idle State, the GPIF Data Bus (FD[15:0]) can be either driven or tri-stated, depending on the setting of the IDLEDRV bit (GPIFIDLECS.0):

- If IDLEDRV = 0, the GPIF Data Bus is tri-stated during the Idle State.
- If IDLEDRV = 1, the GPIF Data Bus is actively driven during the Idle State, to the value last placed on the bus by a GPIF Waveform.

CTL Outputs During IDLE

During the IDLE State, the state of CTL[5:0] depends on the following register bits:

- TRICTL (GPIFCTLCFG.7), as described in section 10.2.3.1 Control Output Modes on page 124.
- GPIFCTLCFG[5:0]
- GPIFIDLECTL[5:0].

The combination of these bits defines CTL5:0 during IDLE as follows:

- If TRICTL is '0', GPIFIDLECTL[5:0] directly represent the output states of CTL5:0 during the IDLE State. The GPIFCTLCFG[5:0] bits determine whether the CTL5:0 outputs are CMOS or open drain: If GPIFCTLCFG.x = 0, CTLx is CMOS; if GPIFCTLCFG.x = 1, CTLx is open drain.
- If TRICTL is '1', GPIFIDLECTL[7:4] are the output enables for the CTL[3:0] signals, and GPIFIDLECTL[3:0] are the output values for CTL[3:0]. CTL4 and CTL5 are unavailable in this mode.

Table 10-5 illustrates this relationship.

Table 10-5. Control Outputs (CTLx) During the IDLE State

TRICTL	Control Output	Output State	Output Enable
0	CTL0	GPIFIDLECTL.0	N/A (CTL Outputs are always enabled when TRICTL = 0)
	CTL1	GPIFIDLECTL.1	
	CTL2	GPIFIDLECTL.2	
	CTL3	GPIFIDLECTL.3	
	CTL4	GPIFIDLECTL.4	
	CTL5	GPIFIDLECTL.5	
1	CTL0	GPIFIDLECTL.0	GPIFIDLECTL.4
	CTL1	GPIFIDLECTL.1	GPIFIDLECTL.5
	CTL2	GPIFIDLECTL.2	GPIFIDLECTL.6
	CTL3	GPIFIDLECTL.3	GPIFIDLECTL.7
	CTL4	N/A	
	CTL5	(CTL4 and CTL5 are not available when TRICTL = 1)	

10.3.2.2 Defining States

Each Waveform is made up of a number of States, each of which is defined by a 32 bit State Instruction. Each State can be one of two basic types: a Non-Decision Point (NDP) or a Decision Point (DP).

For 'write' waveforms, the data bus is either driven or tri-stated during each State. For 'read' waveforms, the data bus is either sampled/stored or not sampled during each State.

Non-Decision Point (NDP) States

For NDP States, the control outputs (CTLx) are defined by the GPIF instruction to be either '1', '0', or tri-stated during the entire State. NDP States have a programmable fixed duration in units of IFCLK cycles.

Figure 10-7 illustrates the basic concept of NDP States. A write waveform is shown, and for simplicity all the States are shown with equal spacing. Although there are a total of six programmable CTL outputs, only one (CTL0) is shown in Figure 10-7.

Figure 10-7. Non-Decision Point (NDP) States

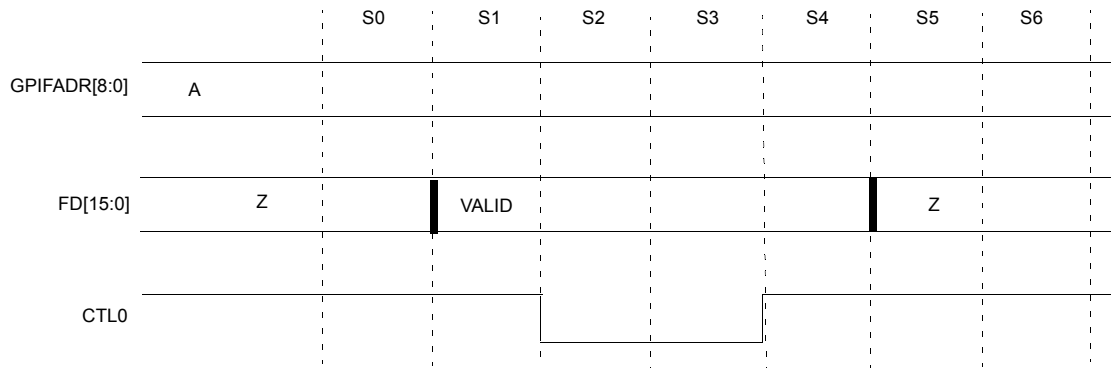

The following information refers to [Figure 10-7](#).

In State 0:

- FD[7:0] is programmed to be tri-stated.
- CTL0 is programmed to be driven to a logic '1'.

In State 1:

- FD[7:0] is programmed to be driven.
- CTL0 is still programmed to be driven to a logic '1'.

In State 2:

- FD[7:0] is programmed to be driven.
- CTL0 is programmed to be driven to a logic '0'.

In State 3:

- FD[7:0] is programmed to be driven.
- CTL0 is still programmed to be driven to a logic '0'.

In State 4:

- FD[7:0] is programmed to be driven.
- CTL0 is programmed to be driven to a logic '1'.

In State 5:

- FD[7:0] is programmed to be tri-stated.
- CTL0 is still programmed to be driven to a logic '1'.

In State 6:

- FD[7:0] is programmed to be tri-stated.
- CTL0 is still programmed to be driven to a logic '1'.

Since all States in this example are coded as NDPs, the GPIF automatically branches from the last State (S6) to the Idle State (S7). This is the State in which the GPIF waits until the next GPIF waveform is triggered by the firmware.

States 2 and 3 in the example are identical, as are States 5 and 6. In a real application, these would probably be combined (there is no need to duplicate a State in order to 'stretch' it, since each NDP State can be assigned a duration in terms of IFCLK cycles). If fewer than 7 States were

defined for this waveform, the Idle State would not automatically be entered after the last programmed State; that last programmed State's State Instruction would have to include an explicit unconditional branch to the Idle State.

Decision Point States

Any State can be designated as a Decision Point (DP). A DP allows the GPIF engine to sample two signals — each of the 'two' can be the same signal, if desired — perform a boolean operation on the sampled values, then branch to other States (or loop back on itself, remaining in the current State) based on the result.

If a State Instruction includes a control task (advance the FIFO pointer, increment the GPIFADR address, and so on), that task is always executed once upon entering the State, regardless of whether the State is a DP or NDP. If the State is a DP that loops back on itself, however, it can be programmed to re-execute the control task on every loop.

With a Decision Point, the GPIF can perform simple tasks (wait until a RDY line is low before continuing to the next State, for instance). Decision point States can also perform more-complex tasks by branching to one State if the operation on the sampled signals results in a logic '1', or to a different State if it results in a logic '0'.

In each State Instruction, the two signals to sample can be selected from any of the following:

- The six external RDY signals (RDY0-RDY5)
- One of the current FIFO's flags (PF, EF, FF)
- The INTRDY bit in the READY register
- A Transaction Count Expired signal (which replaces RDY5)

The State Instruction also specifies a logic function (AND, OR, or XOR) to be applied to the two selected signals. If it is desired to act on the state of only one signal, the usual procedure is to select the same signal twice and specify the logic function as AND.

The State Instruction also specifies which State to branch to if the result of the logical expression is '0,' and which State to branch to if the result of the logical expression is '1.'

Below is an example waveform created using one Decision Point State (State 1); Non-Decision Point States are used for the rest of the waveform.

In Figure 10-8 and Figure 10-9, there is a single Decision Point defined as State 1. In this example, the input ready signal is assumed to be connected to RDY0, and the State Instruction for S1 is configured to branch to State 2 if RDY0 is a logic '0' or to branch to State 1 (for example, loop indefinitely) if RDY0 is a logic '1'.

In Figure 10-8, the GPIF remains in S1 until the RDY0 signal goes low, then branches to S2. Figure 10-9 illustrates the GPIF behavior when the RDY0 signal is *already* low when S1 is entered: The GPIF branches to S2.

Note Although it appears in Figure 10-9 that the GPIF branches immediately from State 1 to State 2, this is not exactly true. Even if RDY0 is already low before the GPIF enters State 1, the GPIF spends one IFCLK cycle in State 1 to evaluate the decision point. The logic function is applied on the rising edge of IFCLK entering State 1. If the logic function holds TRUE at this point, then the branch is effective on the next rising of IFCLK.

Figure 10-8. One Decision Point: Wait States Inserted Until RDY0 Goes Low

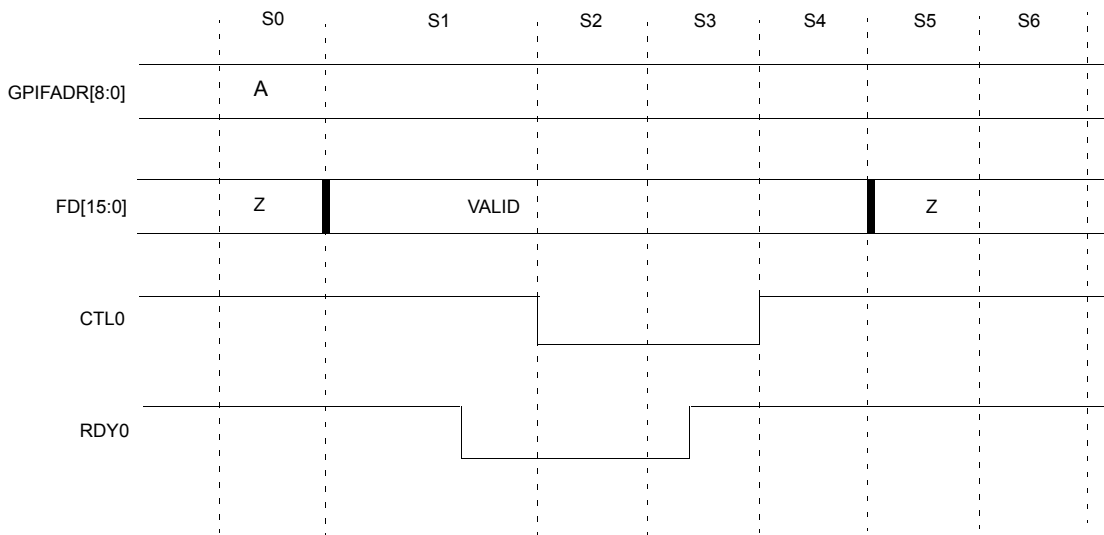
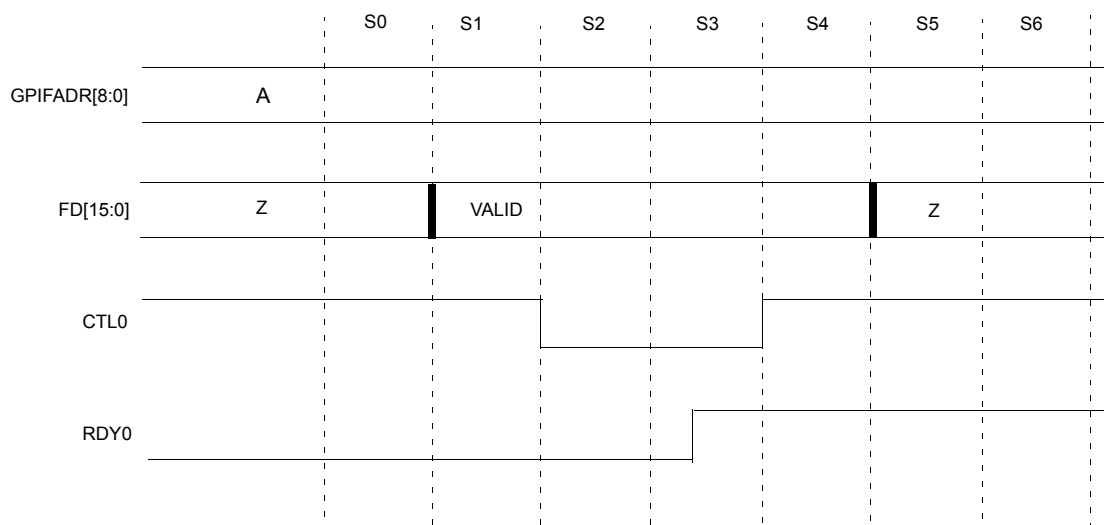

Figure 10-9. One Decision Point: No Wait States Inserted: RDY0 is Already Low at Decision Point 11



10.3.3 Reexecuting a Task Within a DP State

In the simple DP examples shown earlier in this chapter, a control task (e.g., output a word on FD[15:0] and increment GPIFADR[8:0]) executes only once at the start of a DP State, then the GPIF waits, sampling a RDYx input repeatedly until that input 'tells' the GPIF to branch to the next State.

The GPIF also has the capability to reexecute the control task every time the RDYx input is sampled; this feature can

be used to burst a large amount of data without passing through the Idle State (a waveform example is shown in Figure 10-10).

To re-execute a task within a decision point state, the re-execute bit for that decision point must be enabled. This is performed by checking the 'Loop (Re-Execute)' check-box within GPIF Designer (an example is shown in Figure 10-11). Figure 10-13 on page 132 shows an example of a GPIF waveform that uses a DP state which does not re-execute its control tasks.

Figure 10-10. Reexecuting a Task within a DP State

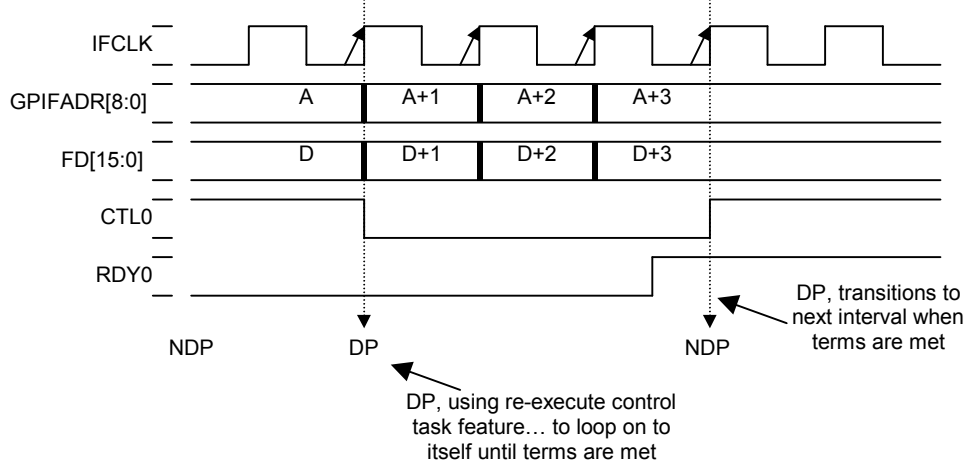

Figure 10-11. GPIF Designer Setup for the Waveform of Figure 10-10

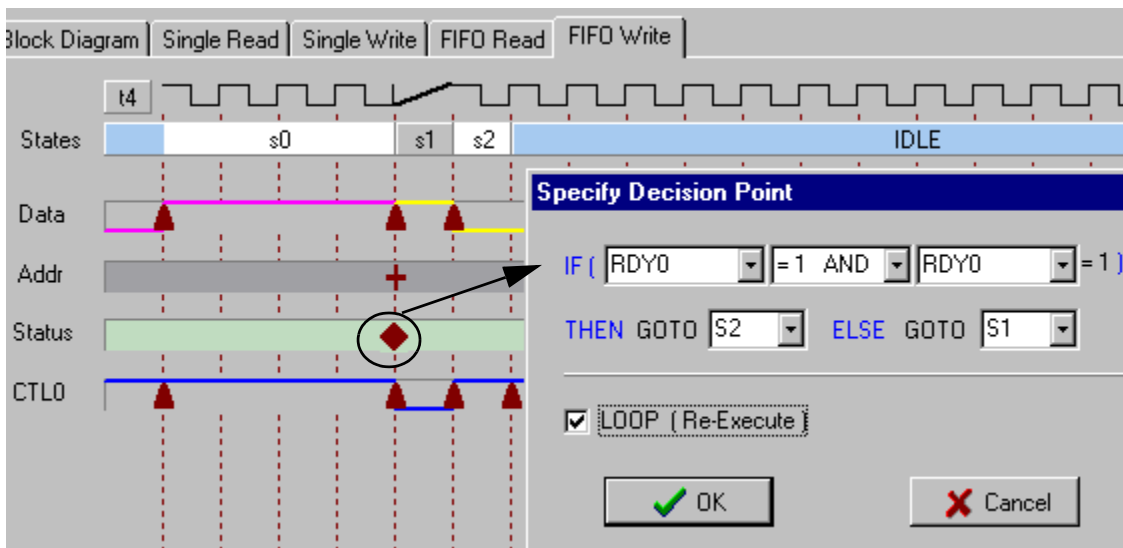

Figure 10-12. GPIF Designer Output for the Waveform of Figure 10-10

State	0	1	2	3	4	5	6	7
AddrMode	Same Val	Inc Val	Same Val	Same Val	Same Val	Same Val	Same Val	Same Val
DataMode	Activate	Activate	No Data	No Data	No Data	No Data	No Data	No Data
NextData	SameData	NextData	SameData	SameData	SameData	SameData	SameData	SameData
Int Trig	No Int	No Int	No Int	No Int	No Int	No Int	No Int	No Int
IF/Wait	Wait 4	IF	Wait 1	Wait 1	Wait 1	Wait 1	Wait 1	Wait 1
Term A		RDY0						
LFUNC		AND						
Term B		RDY0						
Branch1		Then 2						
Branch0		Else 1						
Re-execute		Yes						
CTL0	1	0	1	1	1	1	1	1
CTL1	1	1	1	1	1	1	1	1
CTL2	1	1	1	1	1	1	1	1
CTL3	1	1	1	1	1	1	1	1
CTL4	1	1	1	1	1	1	1	1
CTL5	1	1	1	1	1	1	1	1

Figure 10-13. A DP State That Does NOT Reexecute the Task

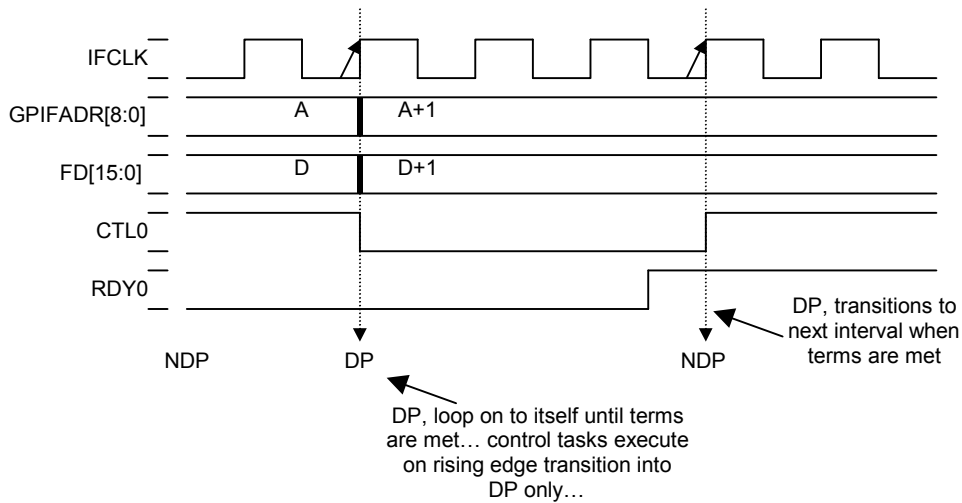

Figure 10-14. GPIF Designer Setup for the Waveform of Figure 10-13

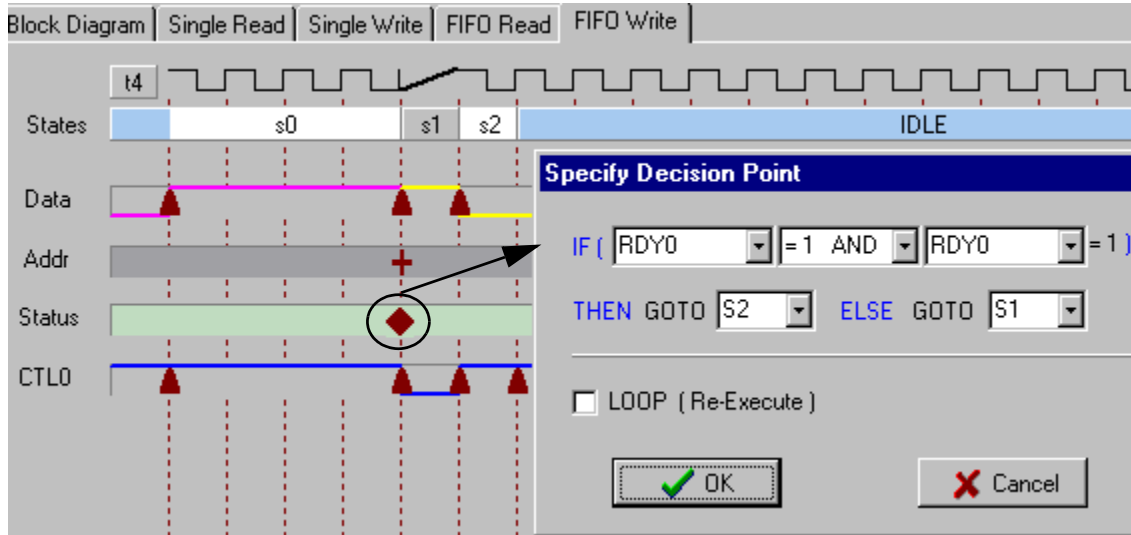

Figure 10-15. GPIF Designer Output for the Waveform of Figure 10-13

State	0	1	2	3	4	5	6	7
AddrMode	Same Val	Inc Val	Same Val	Same Val	Same Val	Same Val	Same Val	
DataMode	Activate	Activate	No Data	No Data	No Data	No Data	No Data	
NextData	SameData	NextData	SameData	SameData	SameData	SameData	SameData	
Int Trig	No Int	No Int	No Int	No Int	No Int	No Int	No Int	
IF/Wait	Wait 4	IF	Wait 1	Wait 1	Wait 1	Wait 1	Wait 1	
Term A		RDY0						
LFUNC		AND						
Term B		RDY0						
Branch1		Then 2						
Branch0		Else 1						
Re-execute		No						
CTL0	1	0	1	1	1	1	1	1
CTL1	1	1	1	1	1	1	1	1
CTL2	1	1	1	1	1	1	1	1
CTL3	1	1	1	1	1	1	1	1
CTL4	1	1	1	1	1	1	1	1
CTL5	1	1	1	1	1	1	1	1

10.3.4 State Instructions

Each State's characteristics are defined by a 4-byte State Instruction. The four bytes are named *LENGTH / BRANCH*, *OPCODE*, *LOGIC FUNCTION*, and *OUTPUT*.

Note that the State Instructions are interpreted differently for Decision Points (DP = 1) and Non-Decision Points (DP = 0).

Non-Decision Point State Instruction (DP = 0)

LENGTH / BRANCH

Bit 7	Bit 6	Bit 5	Bit 4	Bit 3	Bit 2	Bit 1	Bit 0
Number of IFCLK cycles to stay in this State (0 = 256 cycles)							

OPCODE

7	6	5	4	3	2	1	0
x	x	SGL	GINT	INCAD	NEXT/ SGLCRC	DATA	DP = 0

LOGIC FUNCTION

7	6	5	4	3	2	1	0
Not Used							

OUTPUT (if TRICTL Bit = 1)

7	6	5	4	3	2	1	0
OE3	OE2	OE1	OE0	CTL3	CTL2	CTL1	CTL0

OUTPUT (if TRICTL Bit = 0)

7	6	5	4	3	2	1	0
x	x	CTL5	CTL4	CTL3	CTL2	CTL1	CTL0

Decision Point State Instruction (DP = 1)

LENGTH / BRANCH

Bit 7	Bit 6	Bit 5	Bit 4	Bit 3	Bit 2	Bit 1	Bit 0
Re-Execute	x	BRANCHON1			BRANCHON0		

OPCODE

7	6	5	4	3	2	1	0
x	x	SGL	GINT	INCAD	NEXT/SGLCRC	DATA	DP = 1

LOGIC FUNCTION

7	6	5	4	3	2	1	0
LFUNC		TERMA			TERMB		

OUTPUT (if TRICTL Bit = 1)

7	6	5	4	3	2	1	0
OE3	OE2	OE1	OE0	CTL3	CTL2	CTL1	CTL0

OUTPUT (if TRICTL Bit = 0)

7	6	5	4	3	2	1	0
x	x	CTL5	CTL4	CTL3	CTL2	CTL1	CTL0

LENGTH / BRANCH Register. This register's interpretation depends on the DP bit:

- For DP = 0 (Non-Decision Point), this is a LENGTH field; it holds the fixed duration of this State in IFCLK cycles. A value of '0' is interpreted as 256 IFCLK cycles.
- For DP = 1 (Decision Point), this is a BRANCH field; it specifies the State to which the GPIF branches.

BRANCHON1 Specifies the State to which the GPIF branches if the logic expression evaluates to '1'.

BRANCHON0 Specifies the State to which the GPIF branches if the logic expression evaluates to '0'.

Re-Execute Setting this bit allows the DP to re-execute its control tasks.

OPCODE Register. This register sets a number of State characteristics.

SGL Bit. This bit has no effect in a Single Read or Single Write waveform. In a FIFO waveform, it specifies whether a single data transaction should occur (from/to the SGLDATH:L or UDMACRCH:L registers), even in a FIFO Write or FIFO Read transaction. See also NEXT/SGLCRC, below.

- 1 = Use SGLDATH:L or UDMACRCH:L.
- 0 = Use the FIFO.

GINT Bit. This bit specifies whether to generate a GPIFWF interrupt during this State.

- 1 = Generate GPIFWF interrupt (on INT4) when this State is reached.
- 0 = Do not generate interrupt.

INCAD Bit. This bit specifies whether to increment the GPIF Address lines GPIFADR[8:0].

- 1 = Increment the GPIFADR[8:0] bus at the beginning of this State.
- 0 = Do not increment the GPIFADR[8:0] signals.

NEXT/SGLCRC Bit.

If SGL = 0, specifies whether the FIFO should be advanced at the start of this State.

- 1 = Move the next data in the OUT FIFO to the top.
- 0 = Do not advance the FIFO.

The NEXT bit has no effect when the waveform is applied to an IN FIFO.

If SGL = 1, specifies whether data should be transferred to/from SGLDATH:L or UDMACRCH:L. See also SGL Bit above.

- 1 = Use UDMACRCH:L.

0 = Use SGLDATH:L.

DATA Bit. This bit specifies whether the FIFO Data bus is to be driven, tri-stated, or sampled.

During a write:

- 1 = Drive the FIFO Data bus with the output data.
- 0 = tri-state (do not drive the bus).

During a read:

- 1 = Sample the FIFO Data bus and store the data.
- 0 = Do not sample the data bus.

DP Bit. This bit indicates whether the State is a DP or NDP.

- 1 = Decision Point.
- 0 = Non-Decision Point.

LOGIC FUNCTION Register. This register is used only in DP State Instructions. It specifies the inputs (TERMA and TERMB) and the Logic Function (LFUNC) to apply to those inputs. The result of the logic function determines the State to which the GPIF branches (see also LENGTH /BRANCH Register, above).

TERMA and TERMB bits:

- = 000: RDY0
- = 001: RDY1
- = 010: RDY2
- = 011: RDY3
- = 100: RDY4
- = 101: RDY5 (or Transaction-Count Expiration, if GPI-FREADYCFG.5 = 1)
- = 110: FIFO flag (PF, EF, or FF), preselected via EPxG-PIFFLGSEL
- = 111: INTRDY (Bit 7 of the GPIFREADYCFG register)

LFUNC bits:

- = 00: A AND B
- = 01: A OR B
- = 10: A XOR B
- = 11: \bar{A} AND B

The TERMA and TERMB inputs are sampled at each rising edge of IFCLK. The logic function is applied, then the branch is taken on the next rising edge.

This register is meaningful only for DP Instructions; when the DP bit of the OPCODE register is cleared to '0', the contents of this register are ignored.

OUTPUT Register. This register controls the state of the six Control outputs (CTL5:0) during the entire State defined by this State Instruction.

OEx Bit. If TRICTL = 1, specifies whether the corresponding CTLx output signal is tri-stated.

1 = Drive CTLx

0 = Tri-state CTLx

CTLx Bit. This specifies the state to set each CTLx signal to during this entire State.

1 = High level

If the CTLx bit in the GPIFCTLCFG register is set to '1', the output driver is an open-drain.

If the CTLx bit in the GPIFCTLCFG register is set to '0', the output driver is driven to CMOS levels.

0 = Low level

10.3.4.1 Structure of the Waveform Descriptors

Up to four different Waveforms can be defined. Each Waveform Descriptor comprises up to 7 State Instructions which are loaded into the Waveform Registers as defined in this section.

Table 10-6. Waveform Descriptor Addresses

Waveform Descriptor	Base XDATA Address
0	0xE400
1	0xE420
2	0xE440
3	0xE460

Within each Waveform Descriptor, the State Instructions are packed as described in Table 10-7. Waveform Descriptor 0 is shown as an example. The other Waveform Descriptors follow exactly the same structure but at higher XDATA addresses.

Table 10-7. Waveform Descriptor 0 Structure

XDATA Address	Contents
0xE400	LENGTH / BRANCH [0] (LENGTH / BRANCH field of State 0 of Waveform Program 0)
0xE401	LENGTH / BRANCH [1] (LENGTH / BRANCH field of State 1 of Waveform Program 0)
0xE402	LENGTH / BRANCH [2] (LENGTH / BRANCH field of State 2 of Waveform Program 0)
0xE403	LENGTH / BRANCH [3] (LENGTH / BRANCH field of State 3 of Waveform Program 0)
0xE404	LENGTH / BRANCH [4] (LENGTH / BRANCH field of State 4 of Waveform Program 0)
0xE405	LENGTH / BRANCH [5] (LENGTH / BRANCH field of State 5 of Waveform Program 0)
0xE406	LENGTH / BRANCH [6] (LENGTH / BRANCH field of State 6 of Waveform Program 0)

Table 10-7. Waveform Descriptor 0 Structure (continued)

XDATA Address	Contents
0xE407	Reserved
0xE408	OPCODE[0] (OPCODE field of State 0 of Waveform Program 0)
0xE409	OPCODE[1] (OPCODE field of State 1 of Waveform Program 0)
0xE40A	OPCODE[2] (OPCODE field of State 2 of Waveform Program 0)
0xE40B	OPCODE[3] (OPCODE field of State 3 of Waveform Program 0)
0xE40C	OPCODE[4] (OPCODE field of State 4 of Waveform Program 0)
0xE40D	OPCODE[5] (OPCODE field of State 5 of Waveform Program 0)
0xE40E	OPCODE[6] (OPCODE field of State 6 of Waveform Program 0)
0xE40F	Reserved
0xE410	OUTPUT[0] (OUTPUT field of State 0 of Waveform Program 0)
0xE411	OUTPUT[1] (OUTPUT field of State 1 of Waveform Program 0)
0xE412	OUTPUT[2] (OUTPUT field of State 2 of Waveform Program 0)
0xE413	OUTPUT[3] (OUTPUT field of State 3 of Waveform Program 0)
0xE414	OUTPUT[4] (OUTPUT field of State 4 of Waveform Program 0)
0xE415	OUTPUT[5] (OUTPUT field of State 5 of Waveform Program 0)
0xE416	OUTPUT[6] (OUTPUT field of State 6 of Waveform Program 0)
0xE417	Reserved
0xE418	LOGIC FUNCTION[0] (LOGIC FUNCTION field of State 0 of Waveform Program 0)
0xE419	LOGIC FUNCTION[1] (LOGIC FUNCTION field of State 1 of Waveform Program 0)
0xE41A	LOGIC FUNCTION[2] (LOGIC FUNCTION field of State 2 of Waveform Program 0)
0xE41B	LOGIC FUNCTION[3] (LOGIC FUNCTION field of State 3 of Waveform Program 0)
0xE41C	LOGIC FUNCTION[4] (LOGIC FUNCTION field of State 4 of Waveform Program 0)
0xE41D	LOGIC FUNCTION[5] (LOGIC FUNCTION field of State 5 of Waveform Program 0)
0xE41E	LOGIC FUNCTION[6] (LOGIC FUNCTION field of State 6 of Waveform Program 0)
0xE41F	Reserved

10.3.4.2 Terminating a GPIF Transfer

Once a GPIF transfer is initiated, the ONLY way to terminate the transfer is to either:

- have it terminate naturally when the byte count expires or
- have the 8051 terminate and abort the transfer by writing to the GPIFABORT register.

Once a GPIF transfer is triggered, it does not terminate until the Transaction Count (TC) has expired. The GPIF engine checks the state of the TC only when in IDLE state. While designing a GPIF waveform, you must have the waveform

pass through an IDLE state in order for the GPIF to check the TC and finally terminate when TC has expired.

GPIF does allow you to save time and avoid going through the IDLE state by using the 'Transaction Count Expired' (TCxpire) signal. This TCxpire replaces RDY5, if GPI-FREADYCFG.5 = 1. Section 10.4.3.2 Reading the Transaction-Count Status in a DP State on page 150 provides further information on this.

10.4 Firmware

Table 10-8. Registers Associated with GPIF Firmware

GPIFTRIG (SFR)	EPxCFG
GPIFSGLDATH (SFR)	EPxFIFOCFG
GPIFSGLDATLX (SFR)	EPxAUTOINLENH/L
GPIFSGLDATLNOX (SFR)	EPxFIFOPFH/L
EPxGPIFTRIG	EP2468STAT(SFR)
XGPIFSGLDATH	EP24FIFOFLGS(SFR)
XGPIFSGLDATLX	EP68FIFOFLGS(SFR)
XGPIFSGLDATLNOX	EPxCS
GPIFABORT	EPxFIFOFLGS
GPIFIE	
GPIFIRQ	EPxFIFOIE
GPIFTCB3	EPxFIFOIRQ
GPIFTCB2	INT2IVEC
GPIFTCB1	INT4IVEC
GPIFTCB0	INTSETUP
	IE (SFR)
EPxBCH/L	IP (SFR)
EPxFIFOBCH/L	INT2CLR(SFR)
EPxFIFOBUF	INT4CLR(SFR)
INPKTEND/OUTPKTEND	EIE (SFR)
	EXIF (SFR)

The 'x' in these register names represents 2, 4, 6, or 8; endpoints 0 and 1 are not associated with the Slave FIFOs.

The GPIF Designer utility, distributed with the Cypress EZ-USB Development Kit, generates C code which may be linked with the rest of an application's source code. Except for GpifInit(), the *GPIF Designer* output source file does not include the following basic GPIF framework and functions.

```

TD_Init():
... ..
GpifInit(); // Configures GPIF from GPIF Designer generated waveform data

// TODO: configure other endpoints, etc. here

// TODO: arm OUT buffers here

// setup INT4 as internal source for GPIF interrupts
// using INT4CLR (SFR), automatically enabled
// INTSETUP |= 0x03; //Enable INT4 Autovectoring
// SYNCDELAY;
// GPIFIE = 0x03; // Enable GPIFDONE and GPIFWF interrupts
// SYNCDELAY;
// EIE |= 0x04; // Enable INT4 ISR, EIE.2(EIEX4)=1

// TODO: configure GPIF interrupts to meet your needs here

```

```

... ..

void GpifInit( void )
{
    BYTE i;

    // Registers which require a synchronization delay, see section 15.14
    // FIFORESET          FIFOPINPOLAR
    // INPKTEND          OUTPKTEND
    // EPxBCH:L          REVCTL
    // GPIFTCB3          GPIFTCB2
    // GPIFTCB1          GPIFTCB0
    // EPxFIFOPFH:L      EPxAUTOINLENH:L
    // EPxFIFOCFG        EPxGPIIFLGSEL
    // PINFLAGSxx        EPxFIFOIRQ
    // EPxFIFOIE         GPIFIRQ
    // GPIFIE            GPIFADRH:L
    // UDMACRCH:L        EPxGPIFTRIG
    // GPIFTRIG

    // 8051 doesn't have access to waveform memories 'til
    // the part is in GPIF mode.

    IFCONFIG = 0xCE;
    // IFCLKSRC=1      , FIFOs executes on internal clk source
    // xMHz=1          , 48MHz internal clk rate
    // IFCLKOE=0       , Don't drive IFCLK pin signal at 48MHz
    // IFCLKPOL=0      , Don't invert IFCLK pin signal from internal clk
    // ASYNC=1         , master samples asynchronous
    // GSTATE=1        , Drive GPIF states out on PORTE[2:0], debug WF
    // IFCFG[1:0]=10, FX2 in GPIF master mode

    GPIFABORT = 0xFF; // abort any waveforms pending

    GPIFREADYCFG = InitData[ 0 ];
    GPIFCTLCFG = InitData[ 1 ];
    GPIFIDLECS = InitData[ 2 ];
    GPIFIDLECTL = InitData[ 3 ];
    GPIFWFSELECT = InitData[ 5 ];
    GPIFREADYSTAT = InitData[ 6 ];

    // use dual autopointer feature...
    AUTOPTRSETUP = 0x07; // inc both pointers,
                        // ...warning: this introduces program holes
                        // ...at E67B (XAUTODAT1) and E67C (XAUTODAT2)

    // source
    APTR1H = MSB( &WaveData );
    APTR1L = LSB( &WaveData );

    // destination
    AUTOPTRH2 = 0xE4;
    AUTOPTL2 = 0x00;

    // transfer
    for ( i = 0x00; i < 128; i++ )
    {
        EXTAUTODAT2 = EXTAUTODAT1;
    }
}

```

```

}

// Configure GPIF Address pins, output initial value,
PORTCCFG = 0xFF;    // [7:0] as alt. func. GPIFADR[7:0]
OEC = 0xFF;        // and as outputs
PORTECFG |= 0x80;  // [8] as alt. func. GPIFADR[8]
OEE |= 0x80;       // and as output

// ...OR... tri-state GPIFADR[8:0] pins
// PORTCCFG = 0x00; // [7:0] as port I/O
// OEC = 0x00;      // and as inputs
// PORTECFG &= 0x7F; // [8] as port I/O
// OEE &= 0x7F;     // and as input

// GPIF address pins update when GPIFADRH/L written
SYNCDELAY;                //
GPIFADRH = 0x00;          // bits[7:1] always 0
SYNCDELAY;                //
GPIFADRL = 0x00;          // point to PERIPHERAL address 0x0000

// Configure GPIF FlowStates registers for Wave 0 of WaveData
FLOWSTATE = FlowStates[ 0 ];
FLOWLOGIC = FlowStates[ 1 ];
FLOWEQ0CTL = FlowStates[ 2 ];
FLOWEQ1CTL = FlowStates[ 3 ];
FLOWHOLDOFF = FlowStates[ 4 ];
FLOWSTB = FlowStates[ 5 ];
FLOWSTBEDGE = FlowStates[ 6 ];
FLOWSTBHPERIOD = FlowStates[ 7 ];
}

// Set Address GPIFADR[8:0] to PERIPHERAL
void Peripheral_SetAddress( WORD gaddr )
{
    SYNCDELAY;                //
    GPIFADRH = gaddr >> 8;
    SYNCDELAY;                //
    GPIFADRL = ( BYTE )gaddr; // setup GPIF address
}

// Set GPIF Transaction Count
void Peripheral_SetGPIFTC( WORD xfrcnt )
{
    SYNCDELAY;                //
    GPIFTCB1 = xfrcnt >> 8; // setup transaction count
    SYNCDELAY;                //
    GPIFTCB0 = ( BYTE )xfrcnt;
}

#define GPIF_FLGSELPF 0
#define GPIF_FLGSELEF 1
#define GPIF_FLGSELFF 2

// Set EP2GPIF Decision Point FIFO Flag Select (PF, EF, FF)
void SetEP2GPIFFLGSEL( WORD DP_FIFOFlag )
{
    EP2GPIFFLGSEL = DP_FIFOFlag;
}

```

General Programmable Interface

```

// Set EP4GPIF Decision Point FIFO Flag Select (PF, EF, FF)
void SetEP4GPIFFLGSEL( WORD DP_FIFOFlag )
{
    EP4GPIFFLGSEL = DP_FIFOFlag;
}

// Set EP6GPIF Decision Point FIFO Flag Select (PF, EF, FF)
void SetEP6GPIFFLGSEL( WORD DP_FIFOFlag )
{
    EP6GPIFFLGSEL = DP_FIFOFlag;
}

// Set EP8GPIF Decision Point FIFO Flag Select (PF, EF, FF)
void SetEP8GPIFFLGSEL( WORD DP_FIFOFlag )
{
    EP8GPIFFLGSEL = DP_FIFOFlag;
}

// Set EP2GPIF Programmable Flag STOP, overrides Transaction Count
void SetEP2GPIFFSTOP( void )
{
    EP2GPIFFSTOP = 0x01;
}

// Set EP4GPIF Programmable Flag STOP, overrides Transaction Count
void SetEP4GPIFFSTOP( void )
{
    EP4GPIFFSTOP = 0x01;
}

// Set EP6GPIF Programmable Flag STOP, overrides Transaction Count
void SetEP6GPIFFSTOP( void )
{
    EP6GPIFFSTOP = 0x01;
}

// Set EP8GPIF Programmable Flag STOP, overrides Transaction Count
void SetEP8GPIFFSTOP( void )
{
    EP8GPIFFSTOP = 0x01;
}

// write single byte to PERIPHERAL, using GPIF
void Peripheral_SingleByteWrite( BYTE gdata )
{
    while( !( GPIFTRIG & 0x80 ) ) // poll GPIFTRIG.7 Done bit
    {
        ;
    }

    XGPIFSGLDATLX = gdata;           // trigger GPIF
                                     // ...single byte write transaction
}

// write single word to PERIPHERAL, using GPIF
void Peripheral_SingleWordWrite( WORD gdata )
{
    while( !( GPIFTRIG & 0x80 ) ) // poll GPIFTRIG.7 Done bit
    {
        ;
    }
}

```

```

    }

// using registers in XDATA space
  XGPIFSGLDATH = gdata >> 8;
  XGPIFSGLDATLX = gdata;          // trigger GPIF
                                   // ...single word write transaction
}

// read single byte from PERIPHERAL, using GPIF
void Peripheral_SingleByteRead( BYTE xdata *gdata )
{
  static BYTE g_data = 0x00;

  while( !( GPIFTRIG & 0x80 ) ) // poll GPIFTRIG.7 Done bit
  {
    ;
  }

// using registers in XDATA space, dummy read
  g_data = XGPIFSGLDATLX;        // trigger GPIF
                                   // ...single byte read transaction
  while( !( GPIFTRIG & 0x80 ) ) // poll GPIFTRIG.7 Done bit
  {
    ;
  }

// using registers in XDATA space,
  *gdata = XGPIFSGLDATLNOX;     // ...GPIF reads byte from PERIPHERAL
}

// read single word from PERIPHERAL, using GPIF
void Peripheral_SingleWordRead( WORD xdata *gdata )
{
  BYTE g_data = 0x00;

  while( !( GPIFTRIG & 0x80 ) ) // poll GPIFTRIG.7 Done bit
  {
    ;
  }

// using registers in XDATA space, dummy read
  g_data = XGPIFSGLDATLX;        // trigger GPIF
                                   // ...single word read transaction

  while( !( GPIFTRIG & 0x80 ) ) // poll GPIFTRIG.7 Done bit
  {
    ;
  }

// using registers in XDATA space, GPIF reads word from PERIPHERAL
  *gdata = ( ( WORD )XGPIFSGLDATH << 8 ) | ( WORD )XGPIFSGLDATLNOX;
}

#define GPIFTRIGWR 0
#define GPIFTRIGRD 4

#define GPIF_EP2 0
#define GPIF_EP4 1

```

General Programmable Interface

```
#define GPIF_EP6 2
#define GPIF_EP8 3

// write bytes/words to PERIPHERAL, using GPIF and EPxFIFO
// if EPx WORDWIDE=0 then write bytes
// if EPx WORDWIDE=1 then write words
void Peripheral_FIFOwrite( BYTE FIFO_EpNum )
{
    while( !( GPIFTRIG & 0x80 ) ) // poll GPIFTRIG.7 Done bit
    {
        ;
    }

    // trigger FIFO write transactions, using SFR
    GPIFTRIG = FIFO_EpNum; // R/W=0, EP[1:0]=FIFO_EpNum for EPx writes
}

// read bytes/words from PERIPHERAL, using GPIF and EPxFIFO
// if EPx WORDWIDE=0 then read bytes
// if EPx WORDWIDE=1 then read words
void Peripheral_FIFOread( BYTE FIFO_EpNum )
{
    while( !( GPIFTRIG & 0x80 ) ) // poll GPIFTRIG.7 GPIF Done bit
    {
        ;
    }

    // trigger FIFO read transactions, using SFR
    GPIFTRIG = GPIFTRIGRD | FIFO_EpNum; // R/W=1, EP[1:0]=FIFO_EpNum for EPx reads
}
```

10.4.1 Single Read Transactions

Figure 10-16. Firmware Launches a Single Read Waveform, WORDWIDE=0

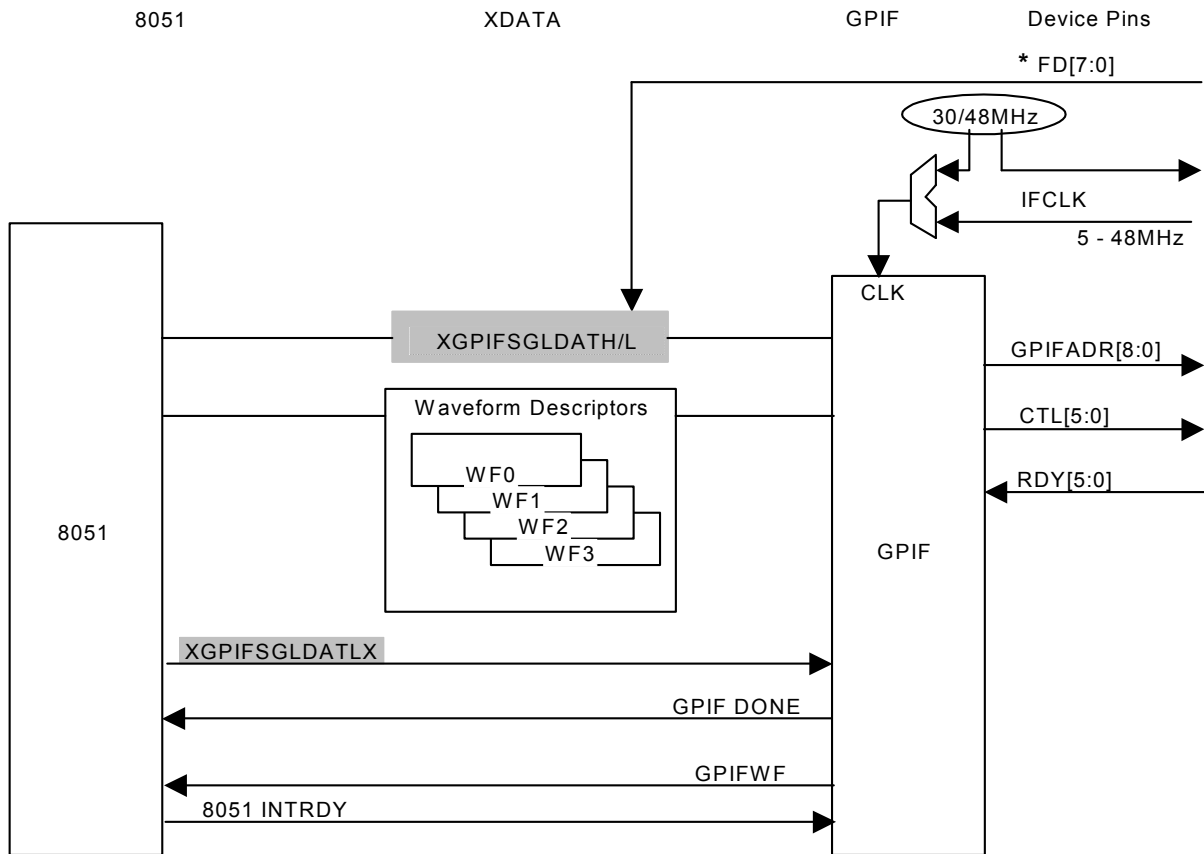

* All EPx WORDWIDE bits must be cleared to '0' for 8 bit single transactions. If any of the EPx WORDWIDE bits are set to '1', then single transactions are 16 bits wide.

Figure 10-17. Single Read Transaction Waveform

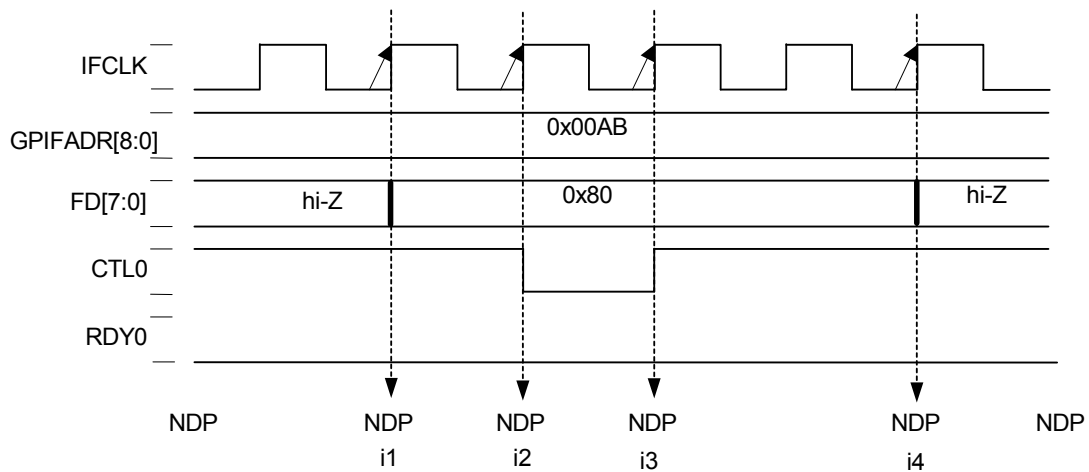

Figure 10-18. GPIF Designer Setup for the Waveform of Figure 10-17

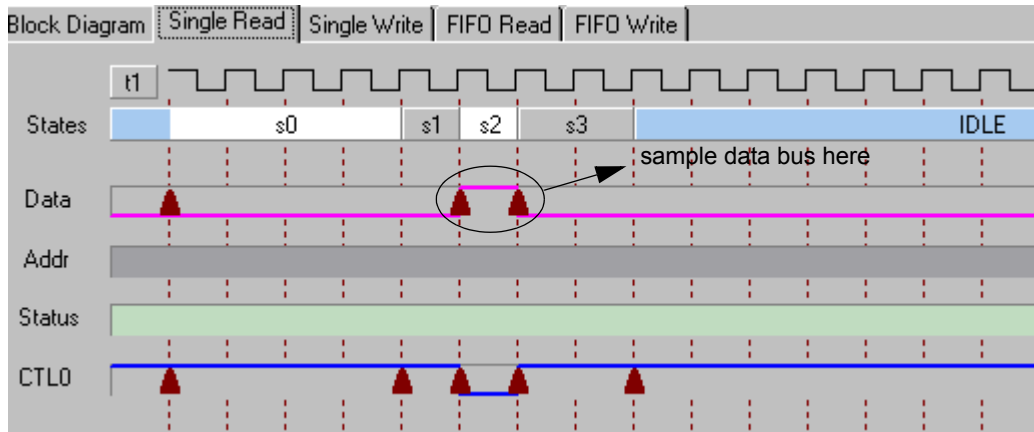

Figure 10-19. GPIF Designer Output for the Waveform of Figure 10-17

State	0	1	2	3	4	5	6	7
AddrMode	Same Val	Same Val	Same Val	Same Val	Same Val	Same Val	Same Val	Same Val
DataMode	No Data	No Data	Activate	No Data	No Data	No Data	No Data	No Data
NextData	SameData	SameData	SameData	SameData	SameData	SameData	SameData	SameData
Int Trig	No Int	No Int	No Int	No Int	No Int	No Int	No Int	No Int
IF/Wait	Wait 4	Wait 1	Wait 1	Wait 2	Wait 1	Wait 1	Wait 1	Wait 1
Term A								
LFUNC								
Term B								
Branch1								
Branch0								
Re-execute								
CTL0	1	1	0	1	1	1	1	1
CTL1	1	1	1	1	1	1	1	1
CTL2	1	1	1	1	1	1	1	1
CTL3	1	1	1	1	1	1	1	1
CTL4	1	1	1	1	1	1	1	1
CTL5	1	1	1	1	1	1	1	1

To perform a Single Read transaction:

1. Initialize the GPIF Configuration Registers and Waveform Descriptors.
2. Check that the GPIF is IDLE by checking if the DONE bit (GPIFIDLECS.7 or GPIFTRIG.7) is set.
3. Perform a dummy **read** of the XGPIFSGLDATLX register to start a single transaction.
4. Wait for the GPIF to indicate that the transaction is complete. When the transaction is complete, the DONE bit (GPIFIDLECS.7 or GPIFTRIG.7) is set to '1'. If enabled, a GPIFDONE interrupt is also generated.
5. Depending on the bus width and the desire to start another transaction, the data read by the GPIF can be retrieved from the XGPIFSGLDATH, XGPIFSGLDATLX, and/or the XGPIFSGLDATLNOX register (or from the SFR-space copies of these registers).

In 16 bit mode **only**, the most significant byte, FD[15:8], of data is read from the XGPIFSGLDATH register.

In 8 and 16 bit modes, the least significant byte of data is read by either:

- reading XGPIFSGLDATLX, which reads the least significant byte and starts another Single Read transaction.
- reading XGPIFSGLDATLNOX, which reads the least significant byte but does **not** start another Single Read transaction.

The following C program fragments (Figure 10-20 on page 145 and Figure 10-21 on page 146) illustrate how to perform a Single Read transaction in 8 bit mode (WORD-WIDE=0):

Figure 10-20. Single Read Transaction Functions

```

#define PERIPHCS 0x00AB
#define AOKAY 0x80
#define BURSTMODE 0x0000
#define TRISTATE 0xFFFF
#define EVER ;;

// prototypes
void GpifInit( void );

// Set Address GPIFADR[8:0] to PERIPHERAL
void Peripheral_SetAddress( WORD gaddr )
{
    if( gaddr < 512 )
    { // drive GPIF address bus w/gaddr
        GPIFADRH = gaddr >> 8;
        SYNCDELAY;
        GPIFADRL = ( BYTE )gaddr; // setup GPIF address
    }
    else
    { // tri-state GPIFADR[8:0] pins
        PORTCCFG = 0x00; // [7:0] as port I/O
        OEC = 0x00; // and as inputs
        PORTECFG &= 0x7F; // [8] as port I/O
        OEE &= 0x7F; // and as input
    }
}

// read single byte from PERIPHERAL, using GPIF
void Peripheral_SingleByteRead( BYTE xdata *gdata )
{
    static BYTE g_data = 0x00;

    while( !( GPIFTRIG & 0x80 ) ) // poll GPIFTRIG.7 Done bit
    {
        ;
    }

    // using registers in XDATA space, dummy read
    g_data = XGPIFSGLDATLX; // to trigger GPIF single byte read transaction

    while( !( GPIFTRIG & 0x80 ) ) // poll GPIFTRIG.7 Done bit
    {
        ;
    }

    // using registers in XDATA space, GPIF read byte from PERIPHERAL here
    *gdata = XGPIFSGLDATLNOX;
}

```

Figure 10-21. Initialization Code for Single Read Transactions

```

void TD_Init( void )
{
    BYTE xdata periph_status;

    ... ..
    GpifInit(); // Configures GPIF from GPIF Designer generated waveform data

    // TODO: configure other endpoints, etc. here

    // TODO: arm OUT buffers here

    // setup INT4 as internal source for GPIF interrupts
    // using INT4CLR (SFR), automatically enabled
    // INTSETUP |= 0x03; //Enable INT4 Autovectoring
    // SYNCDELAY;
    // GPIFIE = 0x03; // Enable GPIFDONE and GPIFWF interrupts
    // SYNCDELAY;
    // EIE |= 0x04; // Enable INT4 ISR, EIE.2(EIEX4)=1

    // TODO: configure GPIF interrupts to meet your needs here
    ... ..

    // get status of peripheral function
    Peripheral_SetAddress( PERIPHCS );
    Peripheral_SingleByteRead( &periph_status );

    if( periph_status == AOKAY )
    { // set it and forget it
        Peripheral_SetAddress( BURSTMODE );
    }
    else
    {
        Peripheral_SetAddress( TRISTATE );
    }
}

```

10.4.2 Single Write Transactions

Figure 10-22. Firmware Launches a Single Write Waveform, WORDWIDE=0

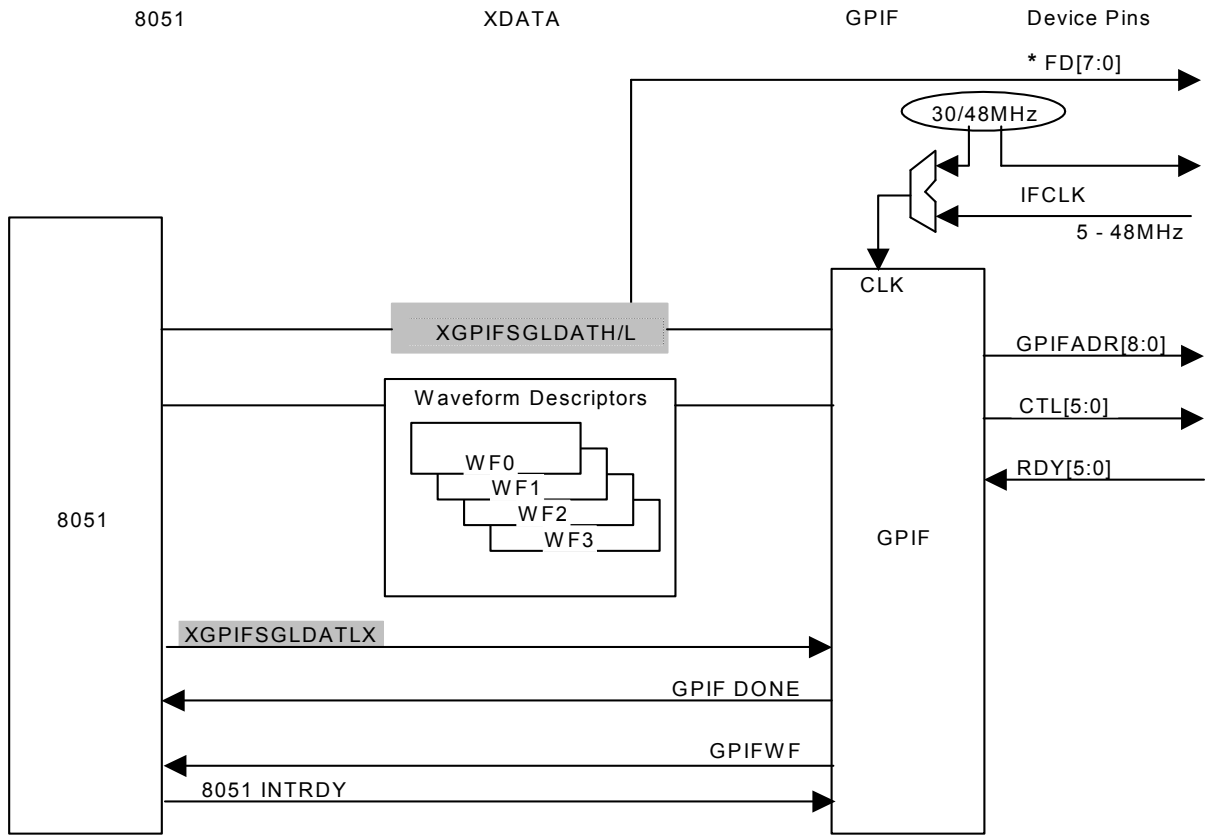

* All EPx WORDWIDE bits must be cleared to zero for 8 bit single transactions. If any of the EPx WORDWIDE bits are set to '1', then single transactions are 16 bits wide.

Figure 10-23. Single Write Transaction Waveform

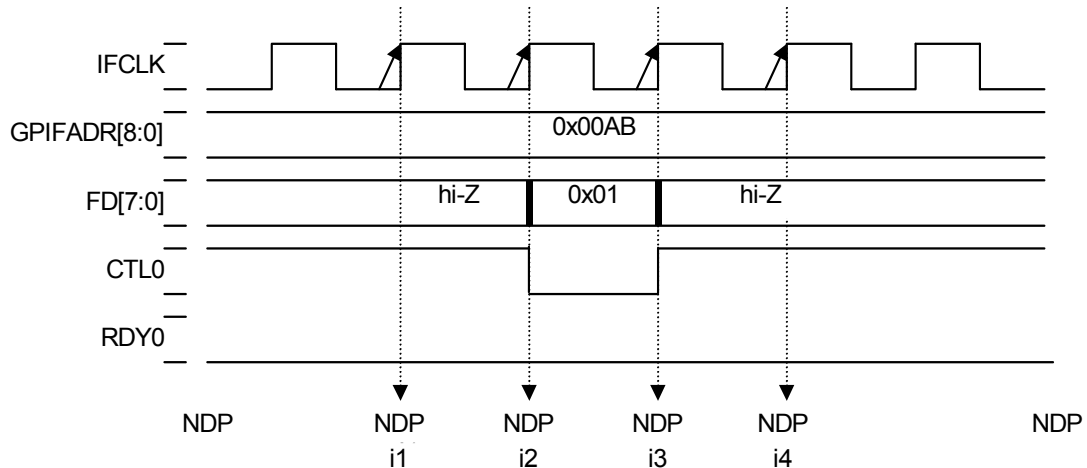

Figure 10-24. GPIF Designer Setup for the Waveform of Figure 10-23

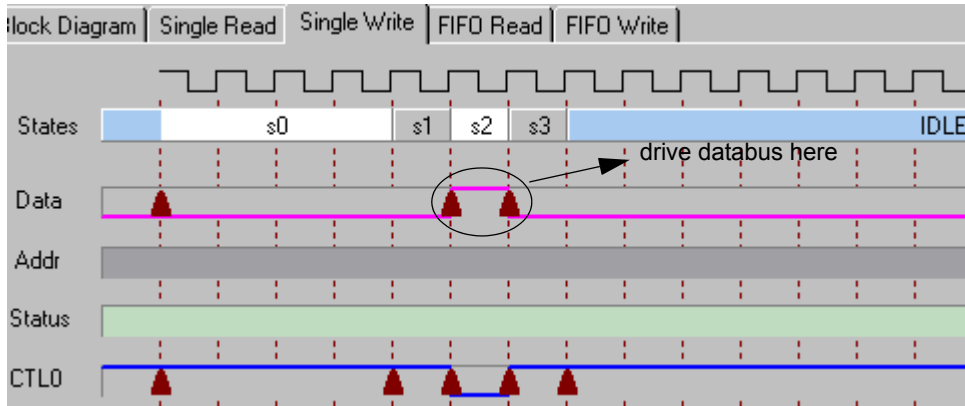

Figure 10-25. GPIF Designer Output for the Waveform of Figure 10-23

State	0	1	2	3	4	5	6	7
AddrMode	Same Val	Same Val	Same Val	Same Val	Same Val	Same Val	Same Val	
DataMode	No Data	No Data	Activate	No Data	No Data	No Data	No Data	
NextData	SameData	SameData	SameData	SameData	SameData	SameData	SameData	
Int Trig	No Int	No Int	No Int	No Int	No Int	No Int	No Int	
IF/Wait	Wait 4	Wait 1	Wait 1	Wait 1	Wait 1	Wait 1	Wait 1	
Term A								
LFUNC								
Term B								
Branch1								
Branch0								
Re-execute								
CTL0	1	1	0	1	1	1	1	1
CTL1	1	1	1	1	1	1	1	1
CTL2	1	1	1	1	1	1	1	1
CTL3	1	1	1	1	1	1	1	1
CTL4	1	1	1	1	1	1	1	1
CTL5	1	1	1	1	1	1	1	1

Single Write transactions are simpler than Single Read transactions because no dummy read operation is required. To execute a Single Write transaction:

1. Initialize the GPIF Configuration Registers and Waveform Descriptors.
2. Check that the GPIF is IDLE by checking if the DONE bit (GPIFIDLECS.7 or GPIFTRIG.7) is set.
3. If in 16 bit mode (WORDWIDE = 1), write the most significant byte of the data to the XGPIFSGLDATH register, then write the least significant byte to the XGPIFSGLDATLX register to start a Single Write transaction.
4. In 8 bit mode, simply write the data to the XGPIFSGLDATLX register to start a Single Write transaction.
5. Wait for the GPIF to indicate that the transaction is complete. When the transaction is complete, the DONE bit

(GPIFIDLECS.7 or GPIFTRIG.7) is set to '1'. If enabled, a GPIFDONE interrupt is also generated.

The following C program fragments (Figure 10-26 and Figure 10-27 on page 149) illustrate how to perform a Single Write transaction in 8 bit mode (WORDWIDE=0):

Figure 10-26. Single Write Transaction Functions

```
#define PERIPHCS 0x00AB
#define P_HSMODE 0x01

// prototypes
void GpifInit( void );

// Set Address GPIFADR[8:0] to PERIPHERAL
void Peripheral_SetAddress( WORD gaddr )
{
    GPIFADRH = gaddr >> 8;
    SYNCDELAY;
    GPIFADRL = ( BYTE )gaddr; // setup GPIF address
}

// write single byte to PERIPHERAL, using GPIF
void Peripheral_SingleByteWrite( BYTE gdata )
{
    while( !( GPIFTRIG & 0x80 ) ) // poll GPIFTRIG.7 Done bit
    {
        ;
    }

    XGPIFSGLDATLX = gdata; // trigger GPIF single byte write transaction
}
```

Figure 10-27. Initialization Code for Single Write Transactions

```
void TD_Init( void )
{
    ... ..
    GpifInit(); // Configures GPIF from GPIF Designer generated waveform data

    // TODO: configure other endpoints, etc. here

    // TODO: arm OUT buffers here

    // setup INT4 as internal source for GPIF interrupts
    // using INT4CLR (SFR), automatically enabled
    // INTSETUP |= 0x03; //Enable INT4 Autovectoring
    // SYNCDELAY;
    // GPIFIE = 0x03; // Enable GPIFDONE and GPIFWF interrupts
    // SYNCDELAY;
    // EIE |= 0x04; // Enable INT4 ISR, EIE.2(EIEX4)=1

    // TODO: configure GPIF interrupts to meet your needs here
    ... ..

    // tell peripheral we are going into high speed xfr mode
    Peripheral_SetAddress( PERIPHCS );
    Peripheral_SingleByteWrite( P_HSMODE );
}
```

10.4.3 FIFO Read and FIFO Write (Burst) Transactions

FIFO Read and FIFO Write waveforms transfer data to and from the EZ-USB's Slave FIFOs (See chapter "Slave FIFOs" on page 99). The waveform is started by writing to EPxGPIFTRIG, where 'x' represents the FIFO (2, 4, 6, or 8) to/from which data should be transferred, or to GPIFTRIG.

A FIFO Read or FIFO Write waveform generally transfers a long stream of data rather than a single byte or word. Usually, the waveform is programmed to terminate after a specified number of transactions or when a FIFO flag asserts (for example, when an IN FIFO is full or an OUT FIFO is empty). A 'transaction' is a transfer of a single byte (if WORDWIDE = 0) or word (if WORDWIDE = 1) to or from a FIFO. Using the GPIF Designer's terminology, a transaction is either an 'Activate Data' for a FIFO Read or a 'Next FIFO Data' for a FIFO Write.

10.4.3.1 Transaction Counter

To use the Transaction Counter for FIFO 'x', load GPIFTCB3:0 with the desired number of transactions (1 to 4,294,967,295). When a FIFO Read or Write waveform is triggered on that FIFO, the GPIF transfers the specified number of bytes (or words, if WORDWIDE = 1) automatically.

This mode of operation is called Long Transfer Mode; when the Transaction Counter is used in this way, the Waveform Descriptor should branch to the Idle State after each transaction.

Each time through the Idle State, the GPIF checks the Transaction Count; when it expires, the waveform terminates and the DONE bit is set. Otherwise, the GPIF re-executes the entire Waveform Descriptor. **Note** In Long Transfer Mode, the DONE bit is not set until the Transaction Count expires.

While the Transaction Count is active, the GPIF checks the Full Flag (for IN FIFOs) or the Empty Flag (for OUT FIFOs) on every pass through the Idle State. If the flag is asserted, the GPIF pauses until the over/underflow threat is removed, then it automatically resumes. In this way, the GPIF automatically throttles data flow in Long Transfer Mode.

The GPIFTCB3:0 registers are readable and they update as transactions occur, so the CPU can read the Transaction Count value at any time.

10.4.3.2 Reading the Transaction-Count Status in a DP State

To sample the transaction-count status in a DP State, set GPIFREADYCFG.5 to '1' (which instructs the EZ-USB to replace the RDY5 input with the transaction-count expiration flag), then launch a FIFO transaction which uses a transaction count. The EZ-USB sets the transaction-count expiration flag to '1' when the transaction count expires. This

feature allows the Transaction Counter to be used without passing through the Idle State after each transaction.

10.4.4 GPIF Flag Selection

The GPIF can examine the PF, EF, or FF (of the current FIFO) during a waveform. One of the three flags is selected by the FS[1:0] bits in the EPxGPIFFLGSEL register; that selected flag is called the GPIF Flag.

10.4.5 GPIF Flag Stop

When EPxGPIFPFSTOP.0 is set to '1', FIFO Read and Write transactions are terminated by the assertion of the GPIF Flag. When this feature is used, it overrides the Transaction Counter; the GPIF waveform terminates (sets DONE to '1') only when the GPIF Flag asserts. If the GPIF Flag is already asserted at the time the waveform is launched, a GPIF DONE interrupt is not generated.

No special programming of the Waveform Descriptors is necessary, and FIFO Waveform Descriptors that transition through the Idle State on each transaction (for example, waveforms that do not use the Transaction Counter) are unaffected. Automatic throttling of the FIFOs in IDLE still occurs, so there is no danger of the GPIF writing to a full FIFO or reading from an empty FIFO.

Note Unless the firmware aborts the GPIF transfer by writing to the GPIFABORT register, only the GPIF Flag assertion terminates the waveform and sets the DONE bit.

A waveform can potentially execute forever if the GPIF Flag never asserts.

Important The GPIF Flag is only automatically tested by the EZ-USB core while transitioning through the IDLE State, and the assertion of the GPIF Flag is not latched. Since the assertion of the GPIF Flag is not latched, if it is asserted and deasserted during the waveform (due to the dynamic relationship between USB host activity and status of the EZ-USB FIFOs), the EZ-USB core would not see the GPIF Flag asserted in the IDLE state.

10.4.5.1 Performing a FIFO Read Transaction

Figure 10-28. Firmware Launches a FIFO Read Waveform

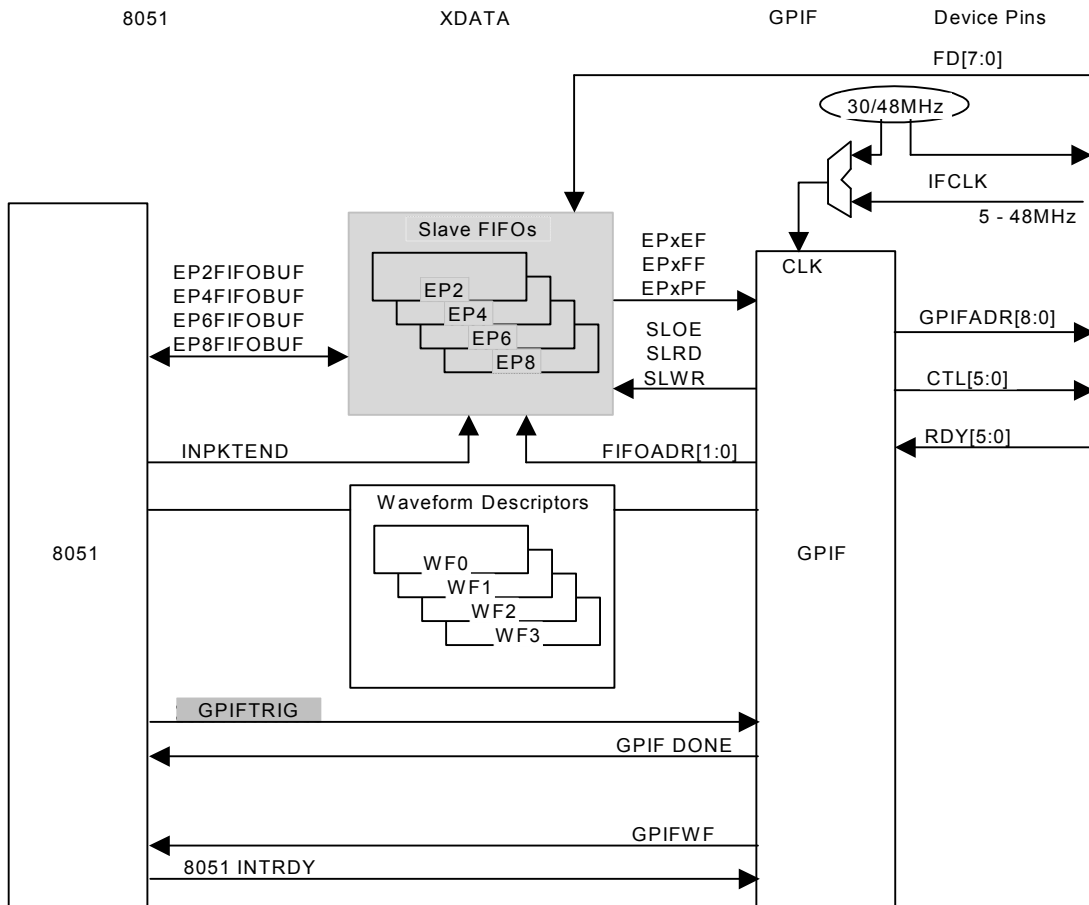

Figure 10-29. Example FIFO Read Transaction

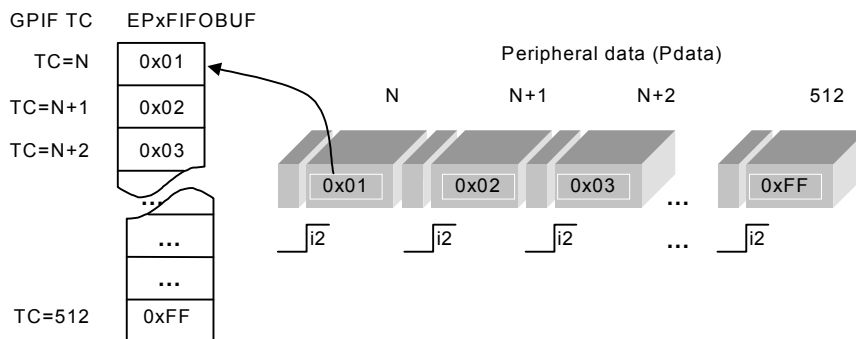
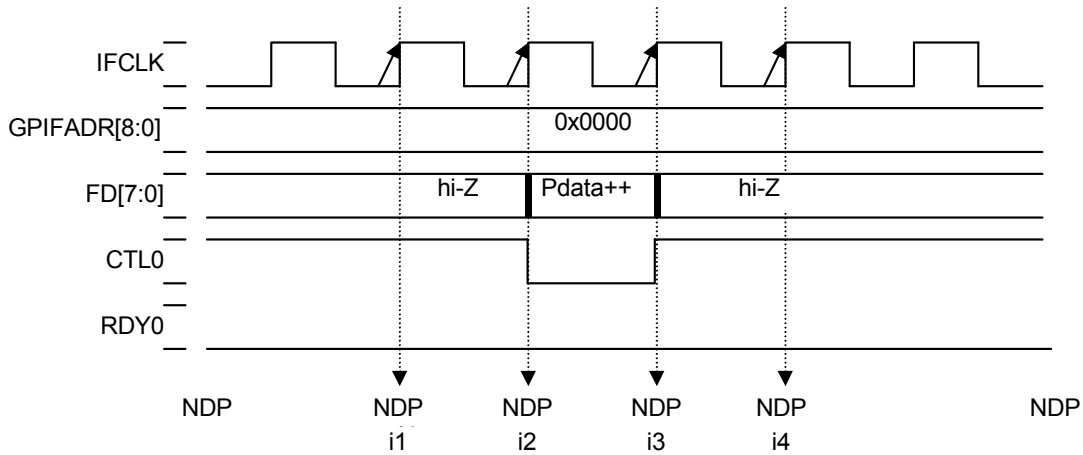

Figure 10-30. FIFO Read Transaction Waveform



The above waveform executes until the Transaction Counter expires (until it counts to 512, in this example). The Transaction Counter is decremented and sampled on each pass through the IDLE state. When the Transaction Counter is used without passing through the IDLE state, the Transaction Counter is decremented on each 'Activate' (which samples the data bus).

Each iteration of the waveform reads a data value from the FIFO data bus into the FIFO, then decrements and checks the Transaction Counter. When it expires, the DONE bit is set to '1' and the GPIFDONE interrupt request is asserted.

Figure 10-31. GPIF Designer Setup for the Waveform of Figure 10-30

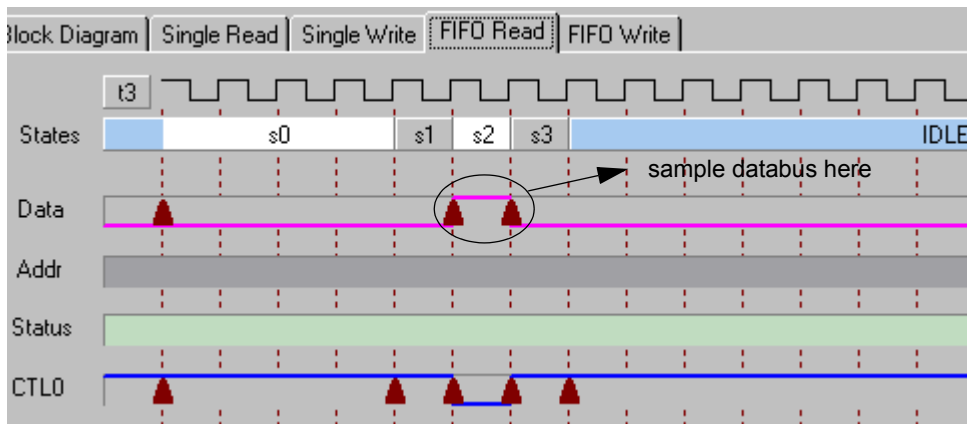

Figure 10-32. GPIF Designer Output for the Waveform of Figure 10-30

State	0	1	2	3	4	5	6	7
AddrMode	Same Val	Same Val	Same Val	Same Val	Same Val	Same Val	Same Val	Same Val
DataMode	No Data	No Data	Activate	No Data	No Data	No Data	No Data	No Data
NextData	SameData	SameData	SameData	SameData	SameData	SameData	SameData	SameData
Int Trig	No Int	No Int	No Int	No Int	No Int	No Int	No Int	No Int
IF/Wait	Wait 4	Wait 1	Wait 1	Wait 1	Wait 1	Wait 1	Wait 1	Wait 1
Term A								
LFUNC								
Term B								
Branch1								
Branch0								
Reexecute								
CTL0	1	1	0	1	1	1	1	1
CTL1	1	1	1	1	1	1	1	1
CTL2	1	1	1	1	1	1	1	1
CTL3	1	1	1	1	1	1	1	1
CTL4	1	1	1	1	1	1	1	1
CTL5	1	1	1	1	1	1	1	1

Typically, when performing a FIFO Read, only one ‘Activate’ is needed in the waveform, since each execution of ‘Activate’ increments the internal FIFO pointer (and EPxBCH:L) automatically.

To perform a FIFO Read Transaction:

1. Program the EZ-USB to detect completion of the transaction. As with all GPIF Transactions, bit 7 of the GPIFTRIG register (the DONE bit) signals when the Transaction is complete.
2. In the GPIFTRIG register, set the RW bit to ‘1’ and load EP[1:0] with the appropriate value for the FIFO which is to receive the data.
3. Program the EZ-USB to commit (‘pass-on’) the data from the FIFO to the endpoint. The data can be transferred from the FIFO to the endpoint by either of the following methods.
 - ❑ AUTOIN=1: CPU is not in the data path; the EZ-USB automatically commits data from the FIFO Data bus to the USB.
 - ❑ AUTOIN=0: Firmware must manually commit data to the USB by writing either EPxBCL or INPKTEND (with SKIP=0).

The following C program fragments (Figure 10-33 on page 154 through Figure 10-36 on page 156) illustrate how to perform a FIFO Read transaction in 8 bit mode (WORDWIDE = 0) with AUTOIN = 0.

Figure 10-33. FIFO Read Transaction Functions

```

#define GPIFTRIGRD 4

#define GPIF_EP2 0
#define GPIF_EP4 1
#define GPIF_EP6 2
#define GPIF_EP8 3

#define BURSTMODE 0x0000
#define HSPKTSIZE 512

... ..

// reads from PERIPHERAL, using GPIF and EPxFIFO
void Peripheral_FIFORead( BYTE FIFO_EpNum )
{
    while( !( GPIFTRIG & 0x80 ) ) // poll GPIFTRIG.7 GPIF Done bit
    {
        ;
    }

    // trigger FIFO read transactions, using SFR
    GPIFTRIG = GPIFTRIGRD | FIFO_EpNum; // R/W=1, EP[1:0]=FIFO_EpNum
                                         // for EPx reads
}

// Set GPIF Transaction Count
void Peripheral_SetGPIFTC( WORD xfrcnt)
{
    GPIFTCB1 = xfrcnt >> 8; // setup transaction count
    SYNCDELAY;
    GPIFTCB0 = ( BYTE )xfrcnt;
}

... ..

```

Figure 10-34. Initialization Code for FIFO Read Transactions

```

void TD_Init( void )
{
    ... ..
    GpifInit(); // Configures GPIF from GPIF Designer generated waveform data

    // TODO: configure other endpoints, etc. here
    EP8CFG = 0xE0; // EP8 is DIR=IN, TYPE=BULK
    SYNCDELAY;
    EP8FIFOCFG = 0x04; // EP8 is AUTOOUT=0, AUTOIN=0, ZEROLEN=1, WORDWIDE=0

    // TODO: arm OUT buffers here

    // setup INT4 as internal source for GPIF interrupts
    // using INT4CLR (SFR), automatically enabled
    // INTSETUP |= 0x03; //Enable INT4 Autovectoring
    // SYNCDELAY;
    // GPIFIE = 0x03; // Enable GPIFDONE and GPIFWF interrupts
    // SYNCDELAY;
    // EIE |= 0x04; // Enable INT4 ISR, EIE.2(EIEX4)=1

    // TODO: configure GPIF interrupts to meet your needs here
    ... ..

    // tell peripheral we are going into high speed xfr mode
    Peripheral_SetAddress( PERIPHCS );
    Peripheral_SingleByteWrite( P_HSMODE );

    // configure some GPIF registers
    Peripheral_SetAddress( BURSTMODE );
    Peripheral_SetGPIFTC( HSPKTSIZE );
}

```

Figure 10-35. FIFO Read w/ AUTOIN = 0, Committing Packets via INPKTEND w/SKIP=0

```

void TD_Poll( void )
{
    ... ..
    if( !( EP68FIFOFLGS & 0x10 ) )
    { // EP8FF=0 when buffer available
      // host is taking EP8 data fast enough
      Peripheral_FIFORead( GPIF_EP8 );
    }

    if( gpifdone_event_flag )
    { // GPIF currently pointing to EP8, last FIFO accessed
      if( !( EP2468STAT & 0x80 ) )
      { // EP8F=0 when buffer available
        INPKTEND = 0x08; // Firmware commits pkt by writing 8 to INPKTEND
        gpifdone_event_flag = 0;
      }
    }
    ... ..
}

```

Figure 10-36. FIFO Read w/ AUTOIN = 0, Committing Packets through EPxBCL

```
void TD_Poll( void )
{
    ... ..
    if( !( EP68FIFOFLGS & 0x10 ) )
    { // EP8FF=0 when buffer available
      // host is taking EP8 data fast enough
      Peripheral_FIFORead( GPIF_EP8 );
    }

    if( gpifdone_event_flag )
    { // GPIF currently pointing to EP8, last FIFO accessed
      if( !( EP2468STAT & 0x80 ) )
      { // EP8F=0 when buffer available
        // modify the data
        EP8FIFOBUF[ 0 ] = 0x02; // <STX>, packet start of text msg
        EP8FIFOBUF[ 7 ] = 0x03; // <ETX>, packet end of text msg
        SYNCDELAY;
        EP8BCH = 0x00;
        SYNCDELAY;
        EP8BCL = 0x08; // pass 8-byte packet on to host
      }
    }
    ... ..
}
```

10.4.6 Firmware Access to IN Packets, (AUTOIN=1)

The only difference between auto (AUTOIN=1) and manual (AUTOIN=0) modes for IN packets is the packet length feature (EPxAUTOINLENH/L) in AUTOIN=1.

Figure 10-37. GPIF FIFO Read Transactions, AUTOIN = 1

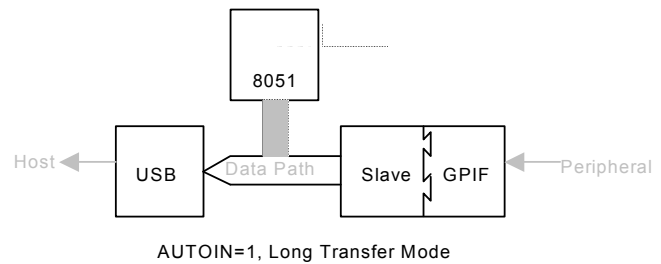
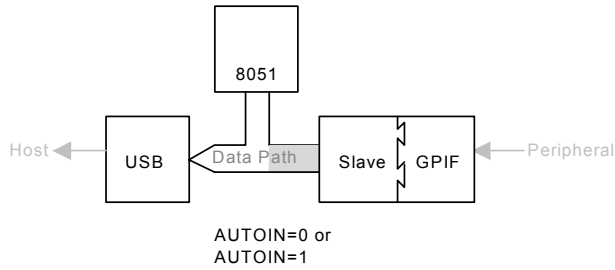

Figure 10-38. FIFO Read Transaction Code, AUTOIN = 1

```
void TD_Init( void )
{
    EP8CFG = 0xE0; // EP8 is DIR=IN, TYPE=BULK
    SYNCDELAY;
    EP8FIFOCFG = 0x0C; // EP8 is AUTOOUT=0, AUTOIN=1, ZEROLEN=1, WORDWIDE=0
    SYNCDELAY;
    EP8AUTOINLENH = 0x02; // if AUTOIN=1, auto commit 512 byte packets
    SYNCDELAY;
    EP8AUTOINLENL = 0x00;
}

void TD_Poll( void )
{
    // no code necessary to xfr data from master to host!
    // AUTOIN=1 and EP8AUTOINLENH:L=512 auto commits IN packets,
    // in 512 byte chunks.
}
```

Figure 10-39. Firmware Intervention, AUTOIN = 0/1



10.4.7 Firmware Access to IN Packets, (AUTOIN = 0)

In manual IN mode (AUTOIN=0), the firmware has the following options:

1. It can commit ('pass-on') packets sent from the master to the host when a buffer is available, by writing the INPKTEND register with the corresponding EPx number and SKIP = 0 (see [Figure 10-40](#)).
2. It can skip a packet by writing to INPKTEND with SKIP = 1. See [Figure 10-41 on page 157](#).
3. It can source or edit a packet (for example, write directly to EPxFIFOBUF) then write the EPxBCL. See [Figure 10-42 on page 158](#).

Figure 10-40. Committing a Packet by Writing INPKTEND with EPx Number (w/SKIP = 0)

```

TD_Poll() :
... ..
if( master_finished_longxfr( ) )
{ // master currently points to EP8, last FIFO accessed
  if( !( EP68FIFOFLGS & 0x10 ) )
  { // EP8FF=0 when buffer available
    INPKTEND = 0x08; // Firmware commits pkt
                    // by writing 0x08 to INPKTEND
    release_master( EP8 );
  }
}
... ..

```

Figure 10-41. Skipping a Packet by Writing to INPKTEND w/SKIP = 1

```

TD_Poll() :
... ..
if( master_finished_longxfr( ) )
{ // master currently points to EP8, last FIFO accessed
  if( !( EP68FIFOFLGS & 0x10 ) )
  { // EP8FF=0 when buffer available
    INPKTEND = 0x88; // Firmware commits pkt
                    // by writing 0x88 to INPKTEND
    release_master( EP8 );
  }
}
... ..

```

Figure 10-42. Sourcing an IN Packet by Writing to EPxBCH:L

```

TD_Poll() :
... ..
if( source_pkt_event )
{ // 100msec background timer fired
  if( holdoff_master( ) )
  { // signaled "busy" to master successful
    while( !( EP68FIFOFLGS & 0x20 ) )
    { // EP8EF=0, when buffer not empty
      ; // wait 'til host takes entire FIFO data
    }

    // Reset FIFO 8.

    FIFORESET = 0x80; // Activate NAK-All to avoid race conditions.
    SYNCDELAY;
    FIFORESET = 0x88; // Reset FIFO 8.
    SYNCDELAY;
    FIFORESET = 0x00; // Deactivate NAK-All.

    EP8FIFOBUF[ 0 ] = 0x02; // <STX>, packet start of text msg
    EP8FIFOBUF[ 1 ] = 0x06; // <ACK>
    EP8FIFOBUF[ 2 ] = 0x07; // <HEARTBEAT>
    EP8FIFOBUF[ 3 ] = 0x03; // <ETX>, packet end of text msg
    SYNCDELAY;
    EP8BCH = 0x00;
    SYNCDELAY;
    EP8BCL = 0x04; // pass src'd buffer on to host
  }
  else
  {
    history_record( EP8, BAD_MASTER );
  }
}
... ..

```

10.4.7.1 Performing a FIFO-Write Transaction

Figure 10-43. Firmware Launches a FIFO Write Waveform

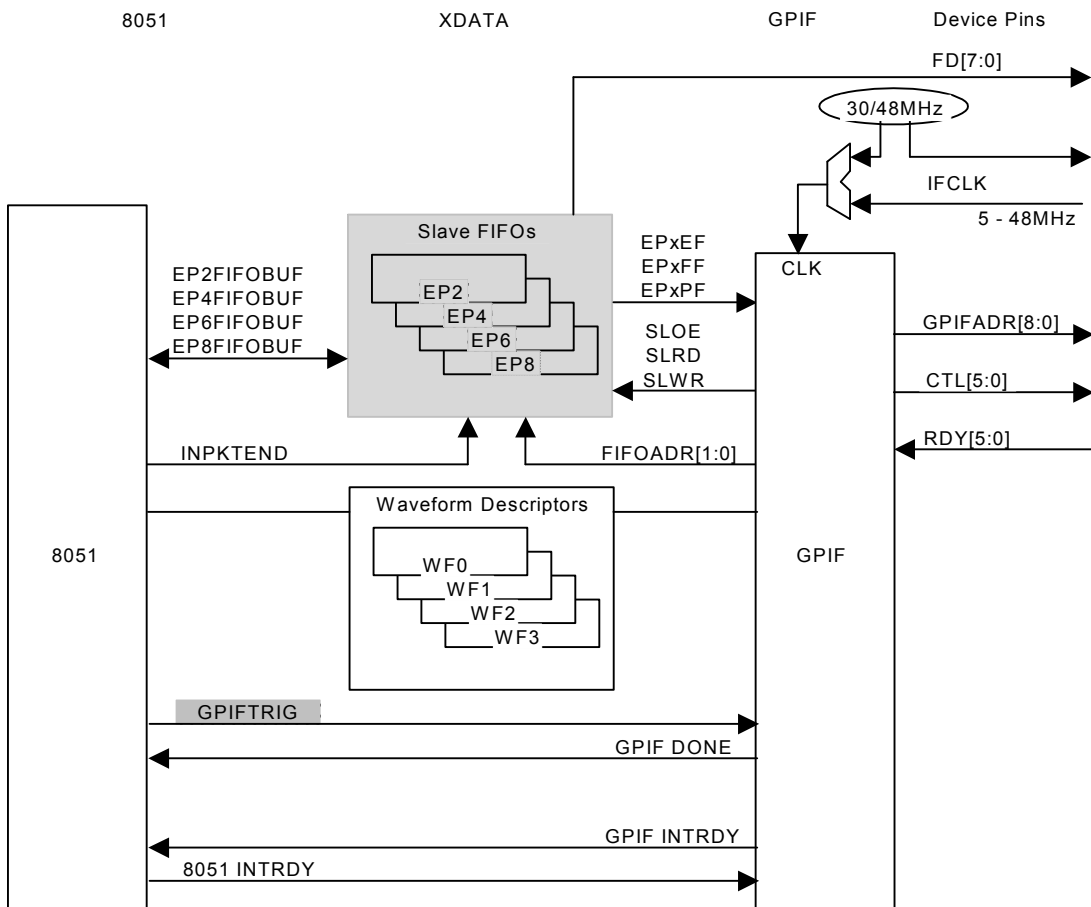

Figure 10-44. Example FIFO Write Transaction

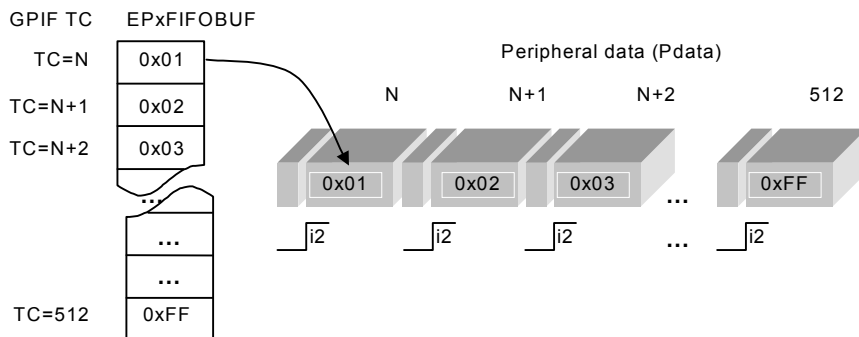
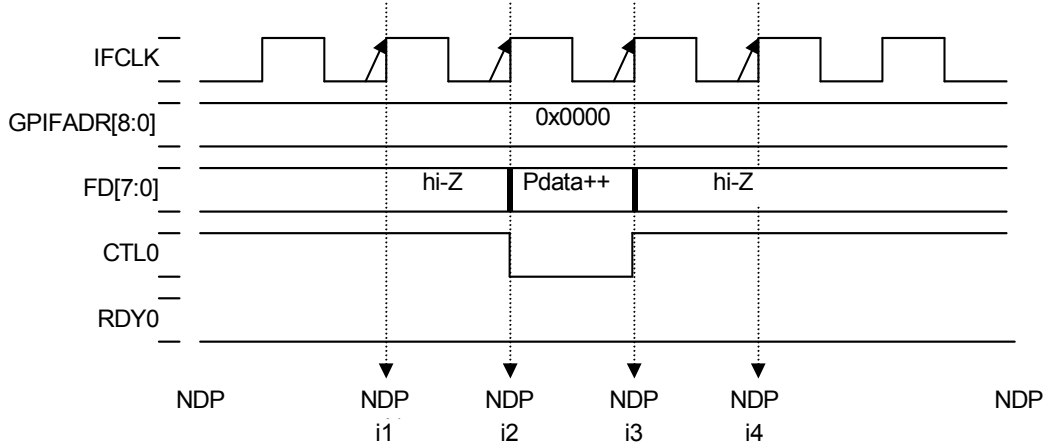

Figure 10-45. FIFO Write Transaction Waveform



The above waveform executes until the Transaction Counter expires (until it counts to 512, in this example). The Transaction Counter is decremented and sampled on each pass through the Idle State. When the Transaction Counter is used without passing through the IDLE state, the Transaction Counter is decremented on each 'Nextdata' (which increments the FIFO pointer).

Each iteration of the waveform writes a data value from the FIFO to the FIFO Data bus, then decrements and checks the Transaction Counter. When it expires, the DONE bit is set to '1' and the GPIFDONE interrupt request is asserted.

Figure 10-46. GPIF Designer Setup for the Waveform of Figure 10-45

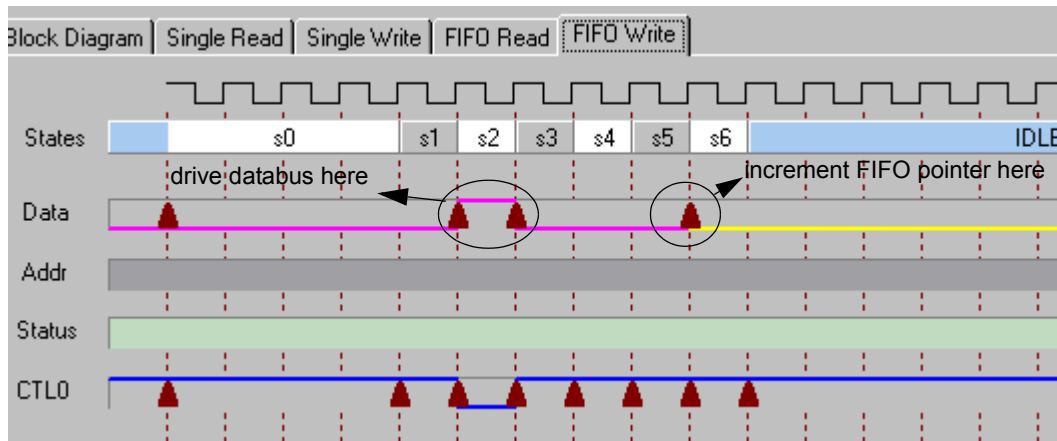

Figure 10-47. GPIF Designer Output for the Waveform of Figure 10-45

State	0	1	2	3	4	5	6	7
AddrMode	Same Val	Same Val	Same Val	Same Val	Same Val	Same Val	Same Val	
DataMode	No Data	No Data	Activate	No Data	No Data	No Data	No Data	
NextData	SameData	SameData	SameData	SameData	SameData	SameData	NextData	
Int Trig	No Int	No Int	No Int	No Int	No Int	No Int	No Int	
IF/Wait	Wait 4	Wait 1	Wait 1	Wait 1	Wait 1	Wait 1	Wait 1	
Term A								
LFUNC								
Term B								
Branch1								
Branch0								
Re-execute								
CTL0	1	1	0	1	1	1	1	1
CTL1	1	1	1	1	1	1	1	1
CTL2	1	1	1	1	1	1	1	1
CTL3	1	1	1	1	1	1	1	1
CTL4	1	1	1	1	1	1	1	1
CTL5	1	1	1	1	1	1	1	1

Typically, when performing a FIFO Write, only one 'Next-Data' is needed in the waveform, since each execution of 'NextData' increments the FIFO pointer.

To perform a FIFO-Write Transaction:

1. Program the EZ-USB to detect completion of the transaction. As with all GPIF Transactions, bit 7 of the GPIFTRIG register (the DONE bit) signals when the Transaction is complete.
2. In the GPIFTRIG register, set the RW bit to '0' and load EP[1:0] with the appropriate value for the FIFO which is to source the data.
3. Program the EZ-USB to commit ('pass-on') the data from the endpoint to the FIFO. The data can be transferred by either of the following methods:
 - AUTOOUT=1: CPU is not in the data path; the EZ-USB automatically commits data from the USB to the FIFO Data bus.
 - AUTOOUT=0: Firmware must manually commit data to the FIFO Data bus by writing EPxBCL.7=0 (firmware can choose to skip the current packet by writing EPxBCL.7=1).

The following C program fragments (Figure 10-48 on page 162 through Figure 10-50 on page 163) illustrate how to perform a FIFO-Read transaction in 8 bit mode (WORD-WIDE = 0) with AUTOOUT = 0.

Figure 10-48. FIFO Write Transaction Functions

```

#define GPIFTRIGWR 0

#define GPIF_EP2 0
#define GPIF_EP4 1
#define GPIF_EP6 2
#define GPIF_EP8 3

#define BURSTMODE 0x0000
#define HSPKTSIZE 512

... ..

// write bytes to PERIPHERAL, using GPIF and EPxFIFO
void Peripheral_FIFOWrite( BYTE FIFO_EpNum )
{
    while( !( GPIFTRIG & 0x80 ) ) // poll GPIFTRIG.7 Done bit
    {
        ;
    }

    // trigger FIFO write transactions, using SFR
    GPIFTRIG = FIFO_EpNum; // R/W=0, EP[1:0]=FIFO_EpNum for EPx writes
}

// Set GPIF Transaction Count
void Peripheral_SetGPIFTC( WORD xfrcnt)
{
    GPIFTCB1 = xfrcnt >> 8; // setup transaction count
    SYNCDELAY;
    GPIFTCB0 = ( BYTE )xfrcnt;
}

... ..

```

Figure 10-49. Initialization Code for FIFO Write Transactions

```

void TD_Init( void )
{
    ... ..
    GpifInit(); // Configures GPIF from GPIF Designer generated waveform data

    // TODO: configure other endpoints, etc. here
    EP2CFG = 0xA2; // EP2 is DIR=OUT, TYPE=BULK, SIZE=512, BUF=2x
    SYNCDELAY;
    EP2FIFOCFG = 0x00; // EP2 is AUTOOUT=0, AUTOIN=0, ZEROLEN=0, WORDWIDE=0
    SYNCDELAY;
    // "all" EP2 buffers automatically arm when AUTOOUT=1

    // TODO: arm OUT buffers here
    OUTPKTEND = 0x82; // Arm both EP2 buffers to "prime the pump"
    SYNCDELAY;
    OUTPKTEND = 0x82;
    SYNCDELAY;

    // setup INT4 as internal source for GPIF interrupts
    // using INT4CLR (SFR), automatically enabled
    // INTSETUP |= 0x03; //Enable INT4 Autovectoring
    // GPIFIE = 0x03; // Enable GPIFDONE and GPIFWF interrupts
    // EIE |= 0x04; // Enable INT4 ISR, EIE.2(EIEX4)=1

    // TODO: configure GPIF interrupts to meet your needs here
    ... ..

    // tell peripheral we are going into high speed xfr mode
    Peripheral_SetAddress( PERIPHCS );
    Peripheral_SingleByteWrite( P_HSMODE );

    // configure some GPIF control registers
    Peripheral_SetAddress( BURSTMODE );
}

```

Figure 10-50. FIFO Write w/ AUTOOUT = 0, Committing Packets through OUTPKTEND

```

void TD_Poll( void )
{
    ... ..
    if( !( EP2468STAT & 0x01 ) )
    { // EP2EF=0 when FIFO "not" empty, host sent pkt.
        OUTPKTEND = 0x02; // SKIP=0, pass buffer on to master

        if( gpifdone_event_flag )
        {
            Peripheral_SetGPIFTC( HSPKTSIZE );
            Peripheral_FIFOwrite( GPIF_EP2 );
            gpifdone_event_flag = 0;
        }
    }
    ... ..
}

```

10.4.8 Firmware Access to OUT packets, (AUTOOUT=1)

To achieve the maximum USB 2.0 bandwidth, the host and master are directly connected when AOUTOOUT=1; the CPU is bypassed and the OUT FIFO is automatically committed to the host.

Figure 10-51. CPU Not in Data Path, AUTOOUT=1

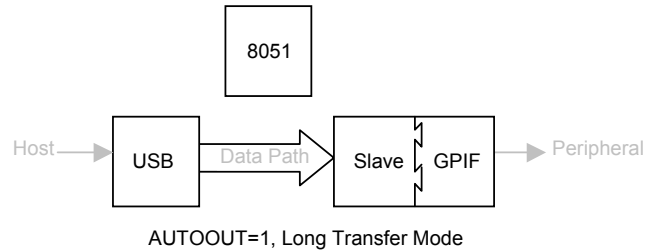

Figure 10-52. TD_Init Example: Configuring AUTOOUT = 1

```

TD_Init():
... ..
REVCTL = 0x03;      // REVCTL.0 and REVCTL.1 set to 1
SYNCDELAY;
EP2CFG = 0xA2;     // EP2 is DIR=OUT, TYPE=BULK, SIZE=512, BUF=2x
SYNCDELAY;
FIFORESET = 0x80;  // Reset the FIFO
SYNCDELAY;
FIFORESET = 0x82;
SYNCDELAY;
FIFORESET = 0x00;
SYNCDELAY;
OUTPKTEND = 0x82; // Arm both EP2 buffers to "prime the pump"
SYNCDELAY;
OUTPKTEND = 0x82;
SYNCDELAY;
EP2FIFOCFG = 0x10; // EP2 is AUTOOUT=1, AUTOIN=0, ZEROLEN=0, WORDWIDE=0
... ..
    
```

Figure 10-53. FIFO-Write Transaction Code, AUTOOUT = 1

```

TD_Poll():
... ..
// no code necessary to xfr data from host to master!
// AUTOOUT=1 auto-commits packets
... ..
    
```

10.4.9 Firmware Access to OUT Packets, (AUTOOUT = 0)

Figure 10-54. Firmware can Skip or Commit, AUTOOUT = 0

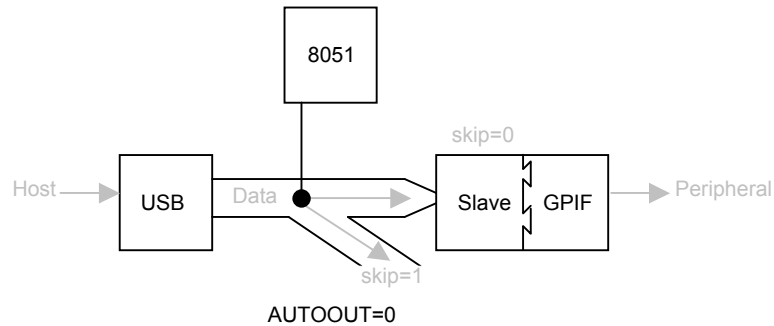

Figure 10-55. Initialization Code for AUTOOUT = 0

```

TD_Init():
... ..
REVCTL = 0x03; // REVCTL.0 and REVCTL.1 set to 1
SYNCDELAY;
EP2CFG = 0xA2; // EP2 is DIR=OUT, TYPE=BULK, SIZE=512, BUF=2x
SYNCDELAY;
FIFORESET = 0x80; // Reset the FIFO
SYNCDELAY;
FIFORESET = 0x82;
SYNCDELAY;
FIFORESET = 0x00;
SYNCDELAY;
EP2FIFOCFG = 0x00; // EP2 is AUTOOUT=0, AUTOIN=0, ZEROLEN=0, WORDWIDE=0
SYNCDELAY;

// OUT endpoints do NOT come up armed
OUTPKTEND = 0x82; // arm first buffer by writing OUTPKTEND w/skip=1
SYNCDELAY;
OUTPKTEND = 0x82; // arm second buffer by writing OUTPKTEND w/skip=1
... ..

```

In manual OUT mode (AUTOOUT = 0), the firmware has the following options:

- It can commit ('pass on') packets sent from the host to the master when a buffer is available, by writing the OUTPKTEND register with the SKIP bit (OUTPKTEND.7) cleared to '0' (see Figure 10-56) and the endpoint number in EP[3:0].
- It can skip packets sent from the host to the master by writing the OUTPKTEND register with the SKIP bit (OUTPKTEND.7) set to '1' (see Figure 10-57) and the endpoint number in EP[3:0].

Figure 10-56. Committing an OUT Packet by Writing OUTPKTEND w/SKIP=0

```

TD_Poll():
... ..
if( !( EP24FIFOFLGS & 0x02 ) )
{ // EP2EF=0 when FIFO "not" empty, host sent pkt.
  OUTPKTEND = 0x02; // SKIP=0, pass buffer on to master
}
... ..

```

Figure 10-57. Skipping an OUT Packet by Writing OUTPKTEND w/SKIP=1

```

TD_Poll() :
... ..
if( !( EP24FIFOFLGS & 0x02 ) )
{ // EP2EF=0 when FIFO "not" empty, host sent pkt.
  OUTPKTEND = 0x82; // SKIP=1, do NOT pass buffer on to master
}
... ..

```

- It can edit the packet (or *source* an entire OUT packet) by writing to the FIFO buffer directly, then writing the length of the packet to EPxBCH:L. The write to EPxBCL commits the edited packet, so EPxBCL should be written after writing EPxBCH (Figure 10-58).

In all cases, the OUT buffer automatically re-arms so it can receive the next packet, after the GPIF has transmitted all data in the OUT buffer.

See section 8.6.2.4 EP2BCH:L, EP4BCH:L, EP6BCH:L, EP8BCH:L on page 93 for a detailed description of the SKIP bit.

The master is not notified when a packet has been skipped by the firmware.

The OUT FIFO is not committed to the host after a hard reset. This means that it is not available to initially accept any OUT packets. In its initialization routine, therefore, the firmware should skip *n* packets (where *n* = 2, 3, or 4 depending on the buffering depth) in order to ensure that the entire FIFO is committed to the host. See Figure 10-59 on page 167.

Figure 10-58. Sourcing an OUT Packet (AUTOOUT = 0)

```

TD_Poll() :
... ..
if( EP24FIFOFLGS & 0x02 )
{
  SYNCDELAY; //
  FIFORESET = 0x80; // nak all OUT pkts. from host
  SYNCDELAY; //
  FIFORESET = 0x82; // advance all EP2 buffers to cpu domain
  SYNCDELAY; //
  EP2FIFOBUF[0] = 0xAA; // create newly sourced pkt. data
  SYNCDELAY; //
  EP2BCH = 0x00;
  SYNCDELAY; //
  EP2BCL = 0x01; // commit newly sourced pkt. to interface fifo

  // beware of "left over" uncommitted buffers

  SYNCDELAY; //
  OUTPKTEND = 0x82; // skip uncommitted pkt. (second pkt.)
  // note: core does not allow pkts. to get out of sequence
  SYNCDELAY; //
  FIFORESET = 0x00; // release "nak all"
}
... ..

```

Figure 10-59. Ensuring that the FIFO is Clear after a Hard Reset

```
TD_Init():
... ..
REVCTL = 0x03; // REVCTL.0 and REVCTL.1 set to 1
SYNCDELAY;
EP2CFG = 0xA2; // EP2 is DIR=OUT, TYPE=BULK, SIZE=512, BUF=2x
SYNCDELAY;
FIFORESET = 0x80; // Reset the FIFO
SYNCDELAY;
FIFORESET = 0x82;
SYNCDELAY;
FIFORESET = 0x00;
SYNCDELAY;
EP2FIFOCFG = 0x00; // EP2 is AUTOOUT=0, AUTOIN=0, ZEROLEN=0, WORDWIDE=0
SYNCDELAY;
// OUT endpoints do NOT come up armed
OUTPKTEND = 0x82; // arm first buffer by writing OUTPKTEND w/skip=1
SYNCDELAY;
OUTPKTEND = 0x82; // arm second buffer by writing OUTPKTEND w/skip=1
... ..
```

10.5 UDMA Interface

The EZ-USB has additional GPIF registers specifically for implementing a UDMA (Ultra-ATA) interface. For more information, refer to the [Registers chapter on page 211](#).

10.6 ECC Generation

The EZ-USB has additional registers specifically for implementing ECC based on the SmartMedia™ standard. For more information, refer to the [Registers chapter on page 211](#).



11. CPU Introduction



11.1 Introduction

The EZ-USB's CPU, an enhanced 8051, is fully described in chapters [Instruction Set, on page 175](#), [Input/Output, on page 181](#), and [Timers/Counters and Serial Interface, on page 193](#). This chapter introduces the processor, its interface to the EZ-USB logic, and describes architectural differences from a standard 8051. [Figure 11-1](#) is a block diagram of the EZ-USB's 8051-based CPU.

Figure 11-1. EZ-USB CPU Features

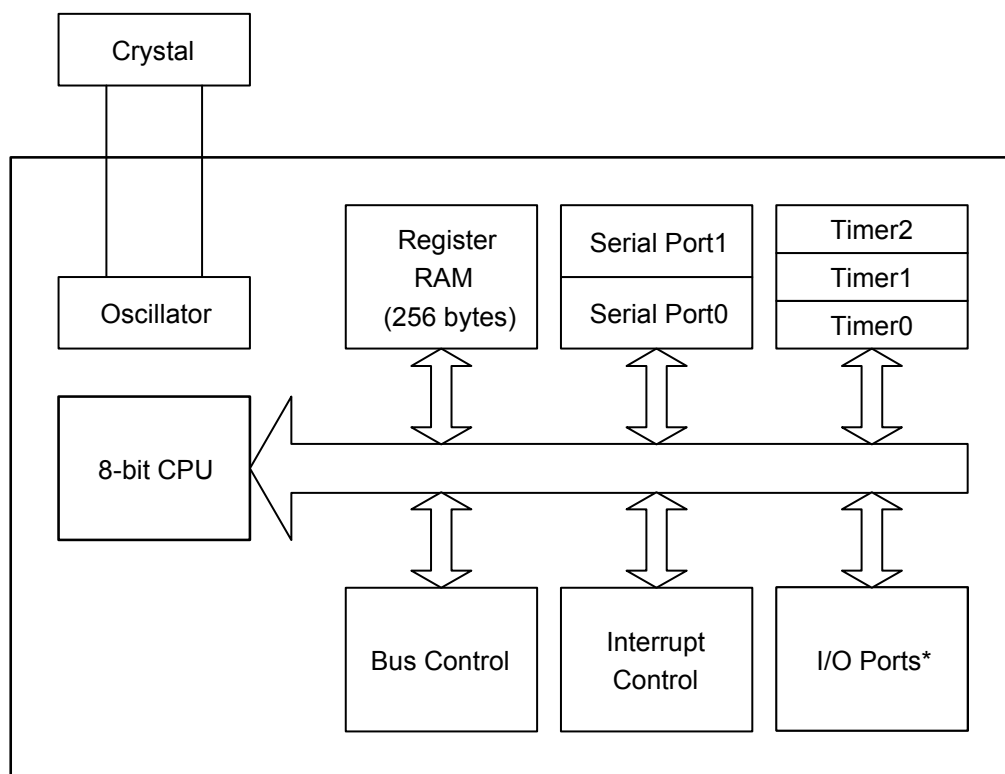

* The EZ-USB family implements I/O ports differently than in the standard 8051

11.2 8051 Enhancements

The EZ-USB uses the standard 8051 instruction set, so it is supported by industry-standard 8051 compilers and assemblers. Instructions execute faster on the EZ-USB than on the standard 8051.

- Wasted bus cycles are eliminated; an instruction cycle uses only four clocks, rather than the standard 8051's 12 clocks
- The EZ-USB's CPU clock runs at 12 MHz, 24 MHz, or 48 MHz—up to four times the clock speed of the standard 8051

In addition to speed improvements, the EZ-USB includes the following architectural enhancements to the CPU.

- A second data pointer
- A second USART
- A third, 16 bit timer (TIMER2)
- A high-speed external memory interface with a non-multiplexed 16 bit address bus
- Eight additional interrupts (INT2-INT6, WAKEUP, T2, and USART1)
- Variable MOVX timing to accommodate fast and slow RAM peripherals
- Two Autopointers (auto-incrementing data pointers)
- Vectored USB and FIFO/GPIF interrupts
- Baud rate timer for 115K/230K baud USART operation
- Sleep mode with three wakeup sources
- An I²C™ bus controller that runs at 100 or 400 kHz
- EZ-USB specific SFRs
- Separate buffers for the SETUP and DATA portions of a USB CONTROL transfer
- A hardware pointer for SETUP data, plus logic to process entire CONTROL transfers automatically
- CPU clock-rate selection of 12, 24 or 48 MHz
- Breakpoint facility
- I/O Port C read and write strobes

11.3 Performance Overview

The EZ-USB has been designed to offer increased performance by executing instructions in a 4-clock bus cycle, as opposed to the 12-clock bus cycle in the standard 8051 (see [Figure 11-2 on page 171](#)). This shortened bus timing improves the instruction execution rate for most instructions by a factor of three over the standard 8051 architectures.

Some instructions require a different number of instruction cycles on the EZ-USB than they do on the standard 8051. In the standard 8051, all instructions except for MUL and DIV take one or two instruction cycles to complete. In the EZ-USB, instructions can take between one and five instruction cycles to complete. However, due to the shortened bus timing of the EZ-USB, every instruction executes faster than on a standard 8051, and the average speed improvement over the entire instruction set is approximately 2.5×. [Table 11-1](#) catalogs the speed improvements.

Table 11-1. EZ-USB Speed Compared to Standard 8051**

Of the 246 EZ-USB opcodes...	
150 execute at	3.0× standard speed
51 execute at	1.5× standard speed
43 execute at	2.0× standard speed
2 execute at	2.4× standard speed
Average Improvement:	2.5×

** Comparison is between EZ-USB and standard 8051 running at the same clock frequency.

Figure 11-2. EZ-USB to Standard 8051 Timing Comparison

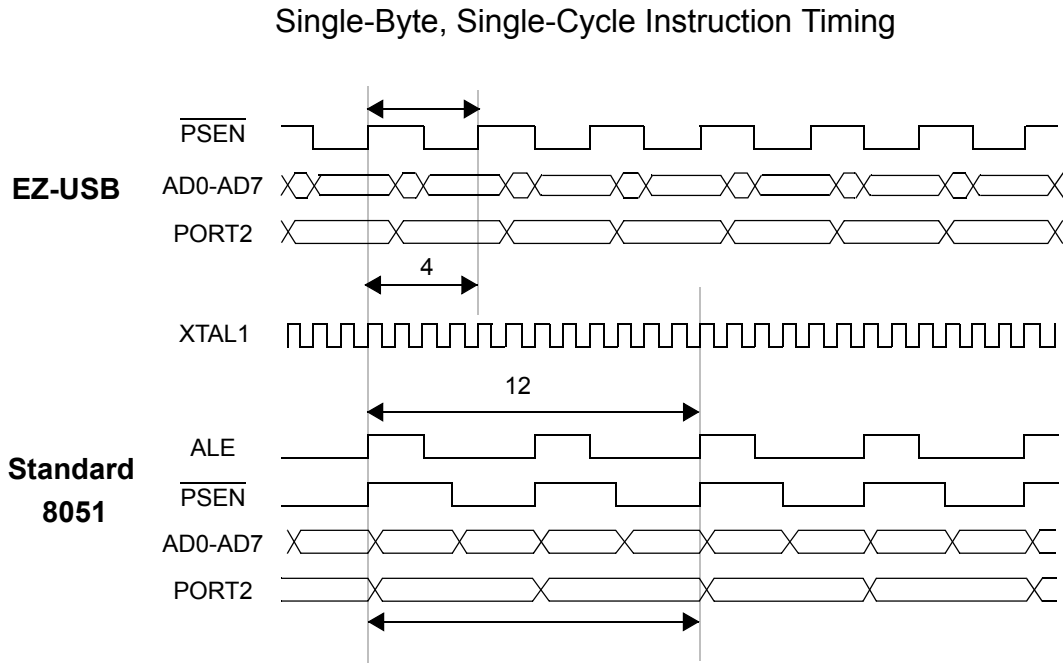

11.4 Software Compatibility

The EZ-USB is object code compatible with the industry standard 8051 microcontroller. That is, object code compiled with an industry standard 8051 compiler or assembler executes on the EZ-USB and is functionally equivalent. However, because the EZ-USB uses a different instruction timing than the standard 8051, existing code with timing loops may require modification.

The EZ-USB instruction timing is identical to that of the Dallas Semiconductor DS80C320.

11.5 803x/805x Feature Comparison

Table 11-2 provides a feature-by-feature comparison between the EZ-USB and several common 803x/805x devices.

Table 11-2. Comparison Between EZ-USB and Other 803x/805x Devices

Feature	Intel				Dallas DS80C320	Cypress EZ-USB
	8031	8051	80C32	80C52		
Clocks per instruction cycle	12	12	12	12	4	4
Program / Data Memory	-	4 kB ROM	-	8 kB ROM	-	16 kB RAM
Internal RAM	128 bytes	128 bytes	256 bytes	256 bytes	256 bytes	256 bytes
Data Pointers	1	1	1	1	2	2
Serial Ports	1	1	1	1	2	2
16-bit Timers	2	2	3	3	3	3
Interrupt sources (internal and external)	5	5	6	6	13	13
Stretch data-memory cycles	no	no	no	no	yes	yes

11.6 EZ-USB/DS80C320 Differences

Although the EZ-USB is similar to the DS80C320 in terms of hardware features and instruction cycle timing, there are some important differences between the EZ-USB and the DS80C320.

11.6.1 Serial Ports

The EZ-USB does not implement serial port framing-error detection and does not implement slave address comparison for multiprocessor communications. Therefore, the EZ-USB also does not implement the following SFRs: SADDR0, SADDR1, SADEN0, and SADEN1.

11.6.2 Timer 2

The EZ-USB does not implement Timer 2 downcounting mode or the downcount enable bit (TMOD2, Bit 0). Also, the EZ-USB does not implement Timer 2 output enable (T2OE) bit (TMOD2, Bit 1). Therefore, the TMOD2 SFR is also not implemented in the EZ-USB.

The EZ-USB Timer 2 overflow output is active for one clock cycle. In the DS80C320, the Timer 2 overflow output is a square wave with a 50% duty cycle.

Note Although the T2OE bit is not present in the EZ-USB, Timer 2 output can still be enabled or disabled via the PORTECFG.2 bit, since the T2OUT pin is multiplexed with PORTE.2.

PORTECFG.2 = 0 configures the pin as a general-purpose I/O pin and disabled Timer 2 output.

PORTECFG.2 = 1 configures the pin as the T2OUT pin and enables Timer 2 output.

11.6.3 Timed Access Protection

The EZ-USB does not implement timed access protection and, therefore, does not implement the TA SFR.

11.6.4 Watchdog Timer

The EZ-USB does not implement a watchdog timer.

11.6.5 Power Fail Detection

The EZ-USB does not implement a power fail detection circuit.

11.6.6 Port I/O

The EZ-USB's port I/O implementation is significantly different from that of the DS80C320, mainly because of the alternate functions shared with most of the I/O pins. See [Input/Output](#), on page 181.

11.6.7 Interrupts

Although the basic interrupt structure of the EZ-USB is similar to that of the DS80C320, five of the interrupt sources are different:

Table 11-3. Differences between EZ-USB and DS80C320 Interrupts

Interrupt Priority	Dallas DS80C320	Cypress EZ-USB
0	Power Fail	RESUME (USB Wakeup)
8	External Interrupt 2	USB
9	External Interrupt 3	I ² C Bus
10	External Interrupt 4	GPIF/FIFOs
12	Watchdog Timer	External Interrupt 6

For more information, refer to the [Timers/Counters](#) and [Serial Interface](#) chapter on page 193.

11.7 EZ-USB Register Interface

The EZ-USB peripheral logic (USB, GPIF, FIFOs, and others) is controlled via a set of memory mapped registers and buffers at addresses 0xE400 through 0xFFFF. These registers and buffers are grouped as follows:

- GPIF Waveform Descriptor Tables
- General configuration
- Endpoint configuration
- Interrupts
- Input/Output
- USB Control
- Endpoint operation
- GPIF/FIFOs
- Endpoint buffers

These registers and their functions are described throughout this manual. A full description of every EZ-USB register appears in the [Registers](#) chapter on page 211.

11.8 EZ-USB Internal RAM

Figure 11-3. EZ-USB Internal Data RAM

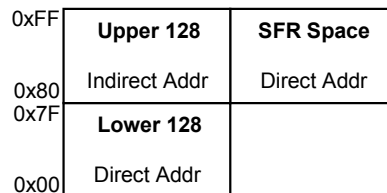

Like the standard 8051, the EZ-USB contains 128 bytes of Internal Data RAM at addresses 0x00-0x7F and a partially populated SFR space at addresses 0x80-0xFF. An additional 128 indirectly-addressed bytes of Internal Data RAM (sometimes called 'IDATA') are also available at addresses 0x80-0xFF.

All other on-chip EZ-USB RAM (program/data memory, endpoint buffer memory, and the EZ-USB control registers) is addressed as though it were off-chip 8051 memory. EZ-USB firmware reads or writes these bytes as data using the MOVX ('move external') instruction, even though the EZ-USB RAM and register set is actually inside the EZ-USB chip. Off-chip memory attached to the EZ-USB address and data buses (only offered in the 128-pin packages) can also be accessed by the MOVX instruction. EZ-USB logic encodes its memory strobe and select signals (RD#, WR#, CS#, OE#, and PSEN#) to eliminate the need for external logic to separate the on-chip and off-chip memory spaces; see the [Memory chapter on page 71](#).

11.9 I/O Ports

The EZ-USB implements I/O ports differently than a standard 8051, as described in [Input/Output, on page 181](#).

The EZ-USB has up to five 8 bit wide, bidirectional I/O ports. Each port is associated with a pair of registers.

- An 'OEx' register. It sets the input/output direction of each of the 8 port pins (0 = input, 1 = output).
- An 'IOx' register. Values written to IOx appear on the pins configured as outputs; values read from IOx indicate the states of the 8 pins, regardless of input/output configuration.

Most I/O pins have alternate functions which are selected using configuration registers. When an alternate configuration is selected for an I/O pin, the corresponding OEx bit is ignored (see section [13.2 I/O Ports on page 181](#)). The default (power on reset) state of all I/O ports is: alternate configurations 'off', all I/O pins configured as 'inputs'.

11.10 Interrupts

All standard 8051 interrupts, plus additional interrupts, are supported by the EZ-USB. [Table 11-4](#) lists the EZ-USB interrupts.

Table 11-4. EZ-USB Interrupts

Standard 8051 Interrupts	Additional EZ-USB Interrupts	Source
INT0		Pin PA0 / INT0#
INT1		Pin PA1 / INT1#
Timer 0		Internal, Timer 0
Timer 1		Internal, Timer 1
Tx0 & Rx0		Internal, USART0
	INT2	Internal, USB
	INT3	Internal, I ² C Bus Controller
	INT4	Pin INT4 (100 and 128 pin only) OR Internal, GPIF/FIFOs
	INT5	Pin INT5# (100 and 128 pin only)
	INT6	Pin INT6 (100 and 128 pin only)
	WAKEUP	Pin WAKEUP or Pin RA3/WU2
	Tx1 & Rx1	Internal, USART1
	Timer 2	Internal, Timer 2

The EZ-USB uses INT2 for 27 different USB interrupts. To help determine which interrupt is active, the EZ-USB provides a feature called Autovectoring, which dynamically changes the address pointed to by the 'jump' instruction at the INT2 vector address. This second level of vectoring automatically transfers control to the appropriate USB interrupt service routine (ISR). The EZ-USB interrupt system, including a full description of the Autovector mechanism, is the subject of the [Interrupts chapter on page 59](#).

11.11 Power Control

The EZ-USB implements a low power mode that allows it to be used in USB bus powered devices (which are required by the USB specification to draw no more than 500 μA when suspended) and other low power applications. The mechanism by which the EZ-USB enters and exits this low power mode is described in detail in the [Power Management chapter on page 77](#).

11.12 Special Function Registers

The EZ-USB was designed to keep coding as standard as possible, to allow easy integration of existing 8051 software development tools. The EZ-USB Special Function Registers (SFR) are summarized in [Table 11-5](#). Standard 8051 SFRs are shown in normal type and EZ-USB-added SFRs are shown in bold type. Full details of the SFRs can be found in the [Registers chapter on page 211](#).

Table 11-5. EZ-USB Special Function Registers (SFR)

x	8x	9x	Ax	Bx	Cx	Dx	Ex	Fx
0	IOA	IOB	IOC	IOD	SCON1	PSW	ACC	B
1	SP	EXIF	INT2CLR	IOE	SBUF1			
2	DPL0	MPAGE	INT4CLR	OEA				
3	DPH0			OEB				
4	DPL1			OEC				
5	DPH1			OED				
6	DPS			OEE				
7	PCON							
8	TCON	SCON0	IE	IP	T2CON	EICON	EIE	EIP
9	TMOD	SBUF0						
A	TL0	AUTOPTRH1	EP2468STAT	EP01STAT	RCAP2L			
B	TL1	AUTOPTRL1	EP24FIFOFLGS	GPIFTRIG	RCAP2H			
C	TH0		EP68FIFOFLGS		TL2			
D	TH1	AUTOPTRH2		GPIFGLDATH	TH2			
E	CKCON	AUTOPTRL2		GPIFGLDATLX				
F			AUTOPTRSETUP	GPIFGLDATLNOX				

Note All unlabeled SFRs are reserved.

11.13 External Address/Data Buses

The 128-pin version of the EZ-USB provides external, non-multiplexed 16-bit address and 8 bit data buses. This differs from the standard 8051, which multiplexes eight pins among three sources: I/O port 0, the external data bus, and the low byte of the external address bus.

A standard 8051 system with external memory requires a demultiplexing address latch, strobed by the 8051 ALE (Address Latch Enable) pin. The external latch is not required by the EZ-USB chip, and no ALE signal is provided. In addition to eliminating the need for this external latch, the non-multiplexed EZ-USB bus saves one cycle per memory-fetch and allows external memory to be connected without sacrificing I/O pins.

The EZ-USB is the sole master of the bus, providing read and write signals to the off-chip memory. The address bus is output-only, and cannot be floated.

11.14 Reset

The various EZ-USB resets and their effects are described in the [Resets chapter on page 83](#).

12. Instruction Set



12.1 Introduction

This chapter provides a technical overview and description of the EZ-USB's assembly-language instruction set.

All EZ-USB instructions are binary code compatible with the standard 8051. The EZ-USB instructions affect bits, flags, and other status functions just as the 8051 instructions do. Instruction timing, however, is different both in terms of the number of clock cycles per instruction cycle and the number of instruction cycles used by each instruction.

Table 12-2 on page 176 lists the EZ-USB instruction set and the number of instruction cycles required to complete each instruction. Table 12-1 defines the symbols and mnemonics used in Table 12-2.

Table 12-1. Legend for Instruction Set Table

Symbol	Function
A	Accumulator
Rn	Register (R0–R7, in the bank selected by RS1:RS0)
direct	Internal RAM location (0x00-0x7F in the 'Lower 128', or 0x80-0xFF in 'SFR' space)
@Ri	Internal RAM location (0x00-0x7F in the 'Lower 128', or 0x80-0xFF in the 'Upper 128') pointed to by R0 or R1
rel	Program-memory offset (-128 to +127 bytes relative to the first byte of the following instruction). Used by conditional jumps and SJMP.
bit	Bit address (0x20-x2F in the 'Lower 128,' and SFRs 0x80, 0x88, ..., 0xF0, 0xF8)
#data	8-bit constant (0-255)
#data16	16-bit constant (0-65535)
addr16	16-bit destination address; used by LCALL and LJMP, which branch anywhere in program memory
addr11	11-bit destination address; used by ACALL and AJMP, which branch only within the current 2K page of program memory (i.e., the upper 5 address bits are copied from the PC)
PC	Program Counter; holds the address of the currently-executing instruction. For the purposes of 'ACALL', 'AJMP', and 'MOVC A,@A+PC' instructions, the PC holds the address of the first byte of the instruction <i>following</i> the currently-executing instruction.

Table 12-2. EZ-USB Instruction Set

Mnemonic	Description	Bytes	Cycles	PSW Flags Affected	Opcode (Hex)
Arithmetic					
ADD A, Rn	Add register to A	1	1	CY OV AC	28-2F
ADD A, direct	Add direct byte to A	2	2	CY OV AC	25
ADD A, @Ri	Add data memory to A	1	1	CY OV AC	26-27
ADD A, #data	Add immediate to A	2	2	CY OV AC	24
ADDC A, Rn	Add register to A with carry	1	1	CY OV AC	38-3F
ADDC A, direct	Add direct byte to A with carry	2	2	CY OV AC	35
ADDC A, @Ri	Add data memory to A with carry	1	1	CY OV AC	36-37
ADDC A, #data	Add immediate to A with carry	2	2	CY OV AC	34
SUBB A, Rn	Subtract register from A with borrow	1	1	CY OV AC	98-9F
SUBB A, direct	Subtract direct byte from A with borrow	2	2	CY OV AC	95
SUBB A, @Ri	Subtract data memory from A with borrow	1	1	CY OV AC	96-97
SUBB A, #data	Subtract immediate from A with borrow	2	2	CY OV AC	94
INC A	Increment A	1	1		04
INC Rn	Increment register	1	1		08-0F
INC direct	Increment direct byte	2	2		05
INC @ Ri	Increment data memory	1	1		06-07
DEC A	Decrement A	1	1		14
DEC Rn	Decrement Register	1	1		18-1F
DEC direct	Decrement direct byte	2	2		15
DEC @Ri	Decrement data memory	1	1		16-17
INC DPTR	Increment data pointer	1	3		A3
MUL AB	Multiply A and B (unsigned; product in B:A)	1	5	CY=0 OV	A4
DIV AB	Divide A by B (unsigned; quotient in A, remainder in B)	1	5	CY=0 OV	84
DA A	Decimal adjust A	1	1	CY	D4
Logical					
ANL, Rn	AND register to A	1	1		58-5F
ANL A, direct	AND direct byte to A	2	2		55
ANL A, @Ri	AND data memory to A	1	1		56-57
ANL A, #data	AND immediate to A	2	2		54
ANL direct, A	AND A to direct byte	2	2		52
ANL direct, #data	AND immediate data to direct byte	3	3		53
ORL A, Rn	OR register to A	1	1		48-4F
ORL A, direct	OR direct byte to A	2	2		45
ORL A, @Ri	OR data memory to A	1	1		46-47
ORL A, #data	OR immediate to A	2	2		44
ORL direct, A	OR A to direct byte	2	2		42
ORL direct, #data	OR immediate data to direct byte	3	3		43
XRL A, Rn	Exclusive-OR register to A	1	1		68-6F
XRL A, direct	Exclusive-OR direct byte to A	2	2		65
XRL A, @Ri	Exclusive-OR data memory to A	1	1		66-67
XRL A, #data	Exclusive-OR immediate to A	2	2		64
XRL direct, A	Exclusive-OR A to direct byte	2	2		62
XRL direct, #data	Exclusive-OR immediate to direct byte	3	3		63
CLR A	Clear A	1	1		E4
CPL A	Complement A	1	1		F4

Table 12-2. EZ-USB Instruction Set (continued)

Mnemonic	Description	Bytes	Cycles	PSW Flags Affected	Opcode (Hex)
SWAP A	Swap nibbles of A	1	1		C4
RL A	Rotate A left	1	1		23
RLC A	Rotate A left through carry	1	1	CY	33
RR A	Rotate A right	1	1		03
RRC A	Rotate A right through carry	1	1	CY	13
Data Transfer					
MOV A, Rn	Move register to A	1	1		E8-EF
MOV A, direct	Move direct byte to A	2	2		E5
MOV A, @Ri	Move data byte at Ri to A	1	1		E6-E7
MOV A, #data	Move immediate to A	2	2		74
MOV Rn, A	Move A to register	1	1		F8-FF
MOV Rn, direct	Move direct byte to register	2	2		A8-AF
MOV Rn, #data	Move immediate to register	2	2		78-7F
MOV direct, A	Move A to direct byte	2	2		F5
MOV direct, Rn	Move register to direct byte	2	2		88-8F
MOV direct, direct	Move direct byte to direct byte	3	3		85
MOV direct, @Ri	Move data byte at Ri to direct byte	2	2		86-87
MOV direct, #data	Move immediate to direct byte	3	3		75
MOV @Ri, A	MOV A to data memory at address Ri	1	1		F6-F7
MOV @Ri, direct	Move direct byte to data memory at address Ri	2	2		A6-A7
MOV @Ri, #data	Move immediate to data memory at address Ri	2	2		76-77
MOV DPTR, #data16	Move 16-bit immediate to data pointer	3	3		90
MOVC A, @A+DPTR	Move code byte at address DPTR+A to A	1	3		93
MOVC A, @A+PC	Move code byte at address PC+A to A	1	3		83
MOVX A, @Ri	Move external data at address Ri to A	1	2-9*		E2-E3
MOVX A, @DPTR	Move external data at address DPTR to A	1	2-9*		E0
MOVX @Ri, A	Move A to external data at address Ri	1	2-9*		F2-F3
MOVX @DPTR, A	Move A to external data at address DPTR	1	2-9*		F0
PUSH direct	Push direct byte onto stack	2	2		C0
POP direct	Pop direct byte from stack	2	2		D0
XCH A, Rn	Exchange A and register	1	1		C8-CF
XCH A, direct	Exchange A and direct byte	2	2		C5
XCH A, @Ri	Exchange A and data memory at address Ri	1	1		C6-C7
XCHD A, @Ri	Exchange the low-order nibbles of A and data memory at address Ri	1	1		D6-D7
* Number of cycles is user-selectable. See Stretch Memory Cycles on page 178.					
Boolean					
CLR C	Clear carry	1	1	CY=0	C3
CLR bit	Clear direct bit	2	2		C2
SETB C	Set carry	1	1	CY=1	D3
SETB bit	Set direct bit	2	2		D2
CPL C	Complement carry	1	1	CY	B3
CPL bit	Complement direct bit	2	2		B2
ANL C, bit	AND direct bit to carry	2	2	CY	82
ANL C, /bit	AND inverse of direct bit to carry	2	2	CY	B0
ORL C, bit	OR direct bit to carry	2	2	CY	72
ORL C, /bit	OR inverse of direct bit to carry	2	2	CY	A0

Table 12-2. EZ-USB Instruction Set (continued)

Mnemonic	Description	Bytes	Cycles	PSW Flags Affected	Opcode (Hex)
MOV C, bit	Move direct bit to carry	2	2	CY	A2
MOV bit, C	Move carry to direct bit	2	2		92
Branching					
ACALL addr11	Absolute call to subroutine	2	3		11-F1
LCALL addr16	Long call to subroutine	3	4		12
RET	Return from subroutine	1	4		22
RETI	Return from interrupt	1	4		32
AJMP addr11	Absolute jump unconditional	2	3		01-E1
LJMP addr16	Long jump unconditional	3	4		02
SJMP rel	Short jump (relative address)	2	3		80
JC rel	Jump if carry = 1	2	3		40
JNC rel	Jump if carry = 0	2	3		50
JB bit, rel	Jump if direct bit = 1	3	4		20
JNB bit, rel	Jump if direct bit = 0	3	4		30
JBC bit, rel	Jump if direct bit = 1, then clear the bit	3	4		10
JMP @ A+DPTR	Jump indirect to address DPTR+A	1	3		73
JZ rel	Jump if accumulator = 0	2	3		60
JNZ rel	Jump if accumulator is non-zero	2	3		70
CJNE A, direct, rel	Compare A to direct byte; jump if not equal	3	4	CY	B5
CJNE A, #d, rel	Compare A to immediate; jump if not equal	3	4	CY	B4
CJNE Rn, #d, rel	Compare register to immediate; jump if not equal	3	4	CY	B8-BF
CJNE @ Ri, #d, rel	Compare data memory to immediate; jump if not equal	3	4	CY	B6-B7
DJNZ Rn, rel	Decrement register; jump if not zero	2	3		D8-DF
DJNZ direct, rel	Decrement direct byte; jump if not zero	3	4		D5
Miscellaneous					
NOP	No operation	1	1		00
There is an additional reserved opcode (A5) that performs the same function as NOP. All mnemonics are copyright 1980, Intel Corporation.					

12.1.1 Instruction Timing

Instruction cycles in the EZ-USB are four clock cycles in length, as opposed to the 12 clock cycles per instruction cycle in the standard 8051. For full details of the instruction-cycle timing differences between the EZ-USB and the standard 8051, See “Performance Overview” on page 170..

In the standard 8051, all instructions except for MUL and DIV take one or two instruction cycles to complete. In the EZ-USB, instructions can take between one and five instruction cycles to complete. For calculating the timing of software loops, etc., use the ‘Cycles’ column from Table 12-2. The ‘Bytes’ column indicates the number of bytes occupied by each instruction.

By default, the EZ-USB’s timer/counters run at 12 clock cycles per increment so that timer-based events have the same timing as with the standard 8051. The timers can also be configured to run at 4 clock cycles per increment to take advantage of the higher speed of the EZ-USB’s CPU.

12.1.2 Stretch Memory Cycles

The EZ-USB can execute a MOVX instruction in as few as two instruction cycles. However, it is sometimes desirable to stretch this value (for example to access slow memory or slow memory-mapped peripherals such as USARTs or LCDs). The EZ-USB’s ‘stretch memory cycle’ (Wait States) feature enables EZ-USB firmware to adjust the speed of data memory accesses (program memory code fetches are not affected).

The three LSBs of the Clock Control Register (CKCON, at SFR location 0x8E) control the stretch value; stretch values between zero and seven may be used. A stretch value of zero adds zero instruction cycles, resulting in MOVX instructions which execute in two instruction cycles. A stretch value of seven adds seven instruction cycles, resulting in MOVX instructions which execute in nine instruction cycles. The stretch value can be changed dynamically under program control.

At power on reset, the stretch value defaults to one (three cycle MOVX); for the fastest data memory access, EZ-USB

software must explicitly set the stretch value to zero. The stretch value affects only data memory access (not program memory).

The stretch value affects the width of the read/write strobe and all related timing. Using a higher stretch value results in a wider read/write strobe, which allows the memory or peripheral more time to respond.

Table 12-3 lists the data memory access speeds for stretch values zero through seven. MD2-0 are the three LSBs of the Clock Control Register (CKCON.2-0). The strobe width timing shown is typical.

CPUCS.4:3 sets the basic clock reference for the EZ-USB. These bits can be modified by EZ-USB firmware at any time. At power on reset, CPUCS.4:3 is set to '00' (12 MHz).

Table 12-3. Data Memory Stretch Values

MD2	MD1	MD0	MOVX Instruction Cycles	Read/Write Strobe Width (Clocks)	Strobe Width @ 12 MHz CPUCS.4:3 = 00	Strobe Width @ 24 MHz CPUCS.4:3 = 01	Strobe Width @ 48 MHz CPUCS.4:3 = 10
0	0	0	2	2	167 ns	83.3 ns	41.7 ns
0	0	1	3 (default)	4	333 ns	167 ns	83.3 ns
0	1	0	4	8	667 ns	333 ns	167 ns
0	1	1	5	12	1000 ns	500 ns	250 ns
1	0	0	6	16	1333 ns	667 ns	333 ns
1	0	1	7	20	1667 ns	833 ns	417 ns
1	1	0	8	24	2000 ns	1000 ns	500 ns
1	1	1	9	28	2333 ns	1167 ns	583 ns

12.1.3 Dual Data Pointers

The EZ-USB employs dual data pointers to accelerate data memory block moves. The standard 8051 data pointer (DPTR) is a 16 bit pointer used to address external data RAM or peripherals. The EZ-USB maintains the standard data pointer as DPTR0 at the standard SFR locations 0x82 (DPL0) and 0x83 (DPH0); it is not necessary to modify existing code to use DPTR0.

The EZ-USB adds a second data pointer (DPTR1) at SFR locations 0x84 (DPL1) and 0x85 (DPH1). The SEL bit (bit 0 of the DPTR Select Register, DPS, at SFR 0x86), selects the active pointer. When SEL = 0, instructions that use the DPTR will use DPL0:DPH0. When SEL = 1, instructions that use the DPTR will use DPL1:DPH1. No other bits of the DPS SFR are used.

All DPTR related instructions use the data pointer selected by the SEL Bit. Switching between the two data pointers by toggling the SEL bit relieves EZ-USB firmware from the burden of saving source and destination addresses when doing a block move; therefore, using dual data pointers provides significantly increased efficiency when moving large blocks of data.

The fastest way to toggle the SEL bit between the two data pointers is via the 'INC DPS' instruction, which toggles bit 0 of DPS between '0' and '1'.

The SFR locations related to the dual data pointers are:

0x82	DPL0	DPTR0 low byte
0x83	DPH0	DPTR0 high byte
0x84	DPL1	DPTR1 low byte
0x85	DPH1	DPTR1 high byte
0x86	DPS	DPTR Select (Bit 0)

12.1.4 Special Function Registers

The four SFRs listed below are related to CPU operation and program execution. Except for the Stack Pointer (SP), each of the registers is bit addressable.

0x81	SP	Stack Pointer
0xD0	PSW	Program Status Word
0xE0	ACC	Accumulator Register
0xF0	B	B Register

Table 12-4 lists the functions of the PSW bits.

Table 12-4. PSW Register - SFR 0xD0

Bit	Function															
PSW.7	CY - Carry flag. This is the unsigned carry bit. The CY flag is set when an arithmetic operation results in a carry from bit 7 to bit 8, and cleared otherwise. In other words, it acts as a virtual bit 8. The CY flag is cleared on multiplication and division. See the 'PSW Flags Affected' column in Table 12-2 on page 176 .															
PSW.6	AC - Auxiliary carry flag. Set to '1' when the last arithmetic operation resulted in a carry into (during addition) or borrow from (during subtraction) the high order nibble, otherwise cleared to '0' by all arithmetic operations. See the 'PSW Flags Affected' column in Table 12-2 on page 176 .															
PSW.5	F0 - User flag 0. Available to EZ-USB firmware for general purpose.															
PSW.4	RS1 - Register bank select bit 1.															
PSW.3	RS0 - Register bank select bit 0. RS1:RS0 select a register bank in internal RAM: <table border="1" style="margin-left: 40px;"> <thead> <tr> <th>RS1</th> <th>RS0</th> <th>Bank Selected</th> </tr> </thead> <tbody> <tr> <td>0</td> <td>0</td> <td>Register bank 0, addresses 0x00-0x07</td> </tr> <tr> <td>0</td> <td>1</td> <td>Register bank 1, addresses 0x08-0x0F</td> </tr> <tr> <td>1</td> <td>0</td> <td>Register bank 2, addresses 0x10-0x17</td> </tr> <tr> <td>1</td> <td>1</td> <td>Register bank 3, addresses 0x18-0x1F</td> </tr> </tbody> </table>	RS1	RS0	Bank Selected	0	0	Register bank 0, addresses 0x00-0x07	0	1	Register bank 1, addresses 0x08-0x0F	1	0	Register bank 2, addresses 0x10-0x17	1	1	Register bank 3, addresses 0x18-0x1F
RS1	RS0	Bank Selected														
0	0	Register bank 0, addresses 0x00-0x07														
0	1	Register bank 1, addresses 0x08-0x0F														
1	0	Register bank 2, addresses 0x10-0x17														
1	1	Register bank 3, addresses 0x18-0x1F														
PSW.2	OV - Overflow flag. This is the signed carry bit. The OV flag is set when a positive sum exceeds 0x7F or a negative sum (in two's complement notation) exceeds 0x80. After a multiply, OV = 1 if the result of the multiply is greater than 0xFF. After a divide, OV = 1 if a divide-by-0 occurred. See the 'PSW Flags Affected' column in Table 12-2 on page 176 .															
PSW.1	F1 - User flag 1. Available to EZ-USB firmware for general purpose.															
PSW.0	P - Parity flag. Contains the modulo-2 sum of the 8 bits in the accumulator (for example, set to '1' when the accumulator contains an odd number of '1' bits, set to '0' when the accumulator contains an even number of '1' bits).															

13. Input/Output



13.1 Introduction

The 56-pin EZ-USB provides two input/output systems:

- A set of programmable I/O pins
- A programmable I2C bus controller

The 100- and 128-pin packages additionally provide two programmable USARTs, which are described in the [Timers/Counters and Serial Interface chapter on page 193](#)

The I/O pins may be configured either for general purpose I/O or for alternate functions (GPIF address and data; FIFO data; USART, timer, and interrupt signals, and others). This chapter describes the usage of the pins in the general purpose configuration, and the methods by which the pins may be configured for alternate functions.

This chapter also provides both the programming information for the I2C interface and the operating details of the EEPROM boot loader. The role of the boot loader is described in the [Enumeration and ReNumeration™ chapter on page 51](#).

13.2 I/O Ports

The EZ-USB's I/O ports are implemented differently than those of a standard 8051.

The EZ-USB has up to five 8-pin bidirectional I/O ports, labeled A, B, C, D, and E. Individual I/O pins are labeled Px.n, where x is the port (A, B, C, D, or E) and n is the pin number (0 to 7).

The 100- and 128-pin EZ-USB packages provide all five ports; the 56-pin package provides only ports A, B, and D.

Each port is associated with a pair of registers:

- An OEx register (where x is A, B, C, D, or E), which sets the input/output direction of each of the 8 pins (0 = input, 1 = output). See the OEx register on page 182.
- An IOx register (where x is A, B, C, D, or E). Values written to IOx appear on the pins which are configured as outputs; values read from IOx indicate the states of the 8 pins, regardless of input/output configuration. See IOx register on page 183.

Most I/O pins have alternate functions which may be selected using configuration registers (see [Table 13-1 on page 185](#) through [Table 13-9 on page 188](#)). Each alternate function is unidirectional; the EZ-USB 'knows' whether the function is an input or an output, so when an alternate configuration is selected for an I/O pin, the corresponding OEx bit is ignored (see [Figure 13-2 on page 184](#) and [Figure 13-3 on page 184](#)).

The default (power on reset) state of all I/O ports is:

- Alternate configurations off
- All I/O pins configured as inputs

[Figure 13-1 on page 182](#) shows the basic structure of an EZ-USB I/O pin.

Figure 13-1. EZ-USB I/O Pin

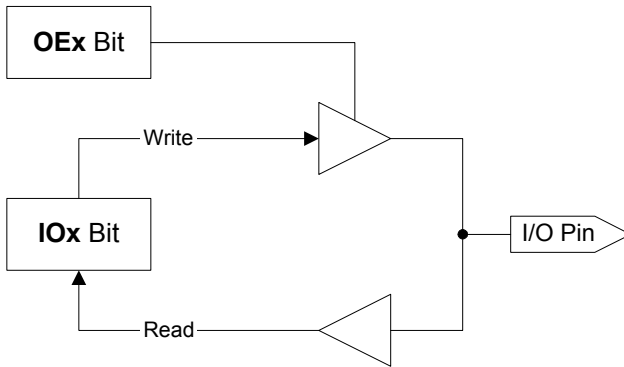

13.3 SFR Registers

OEA								Port A Output Enable	SFR 0xB2
b7	b6	b5	v4	v3	b2	b1	b0		
D7	D6	D5	D4	D3	D2	D1	D0		
R/W	R/W	R/W	R/W	R/W	R/W	R/W	R/W	R/W	
0	0	0	0	0	0	0	0		

OEB								Port B Output Enable	SFR 0xB3
b7	b6	b5	b4	b3	b2	b1	b0		
D7	D6	D5	D4	D3	D2	D1	D0		
R/W	R/W	R/W	R/W	R/W	R/W	R/W	R/W	R/W	
0	0	0	0	0	0	0	0		

OEC								Port C Output Enable	SFR 0xB4
b7	b6	b5	b4	b3	b2	b1	b0		
D7	D6	D5	D4	D3	D2	D1	D0		
R/W	R/W	R/W	R/W	R/W	R/W	R/W	R/W	R/W	
0	0	0	0	0	0	0	0		

OED								Port D Output Enable	SFR 0xB5
b7	b6	b5	b4	b3	b2	b1	b0		
D7	D6	D5	D4	D3	D2	D1	D0		
R/W	R/W	R/W	R/W	R/W	R/W	R/W	R/W	R/W	
0	0	0	0	0	0	0	0		

OEE								Port E Output Enable	SFR 0xB6
b7	b6	b5	b4	b3	b2	b1	b0		
D7	D6	D5	D4	D3	D2	D1	D0		
R/W	R/W	R/W	R/W	R/W	R/W	R/W	R/W	R/W	
0	0	0	0	0	0	0	0		

IOA		Port A (Bit-Addressable)						SFR 0x80
b7	b6	b5	b4	b3	b2	b1	b0	
D7	D6	D5	D4	D3	D2	D1	D0	
R/W	R/W	R/W	R/W	R/W	R/W	R/W	R/W	
x	x	x	x	x	x	x	x	

IOB		Port B (Bit-Addressable)						SFR 0x90
b7	b6	b5	b4	b3	b2	b1	b0	
D7	D6	D5	D4	D3	D2	D1	D0	
R/W	R/W	R/W	R/W	R/W	R/W	R/W	R/W	
x	x	x	x	x	x	x	x	

IOC		Port C (Bit-Addressable)						SFR 0xA0
b7	b6	b5	b4	b3	b2	b1	b0	
D7	D6	D5	D4	D3	D2	D1	D0	
R/W	R/W	R/W	R/W	R/W	R/W	R/W	R/W	
x	x	x	x	x	x	x	x	

IOD		Port D (Bit-Addressable)						SFR 0xB0
b7	b6	b5	b4	b3	b2	b1	b0	
D7	D6	D5	D4	D3	D2	D1	D0	
R/W	R/W	R/W	R/W	R/W	R/W	R/W	R/W	
x	x	x	x	x	x	x	x	

IOE		Port E						SFR 0xB1
b7	b6	b5	b4	b3	b2	b1	b0	
D7	D6	D5	D4	D3	D2	D1	D0	
R/W	R/W	R/W	R/W	R/W	R/W	R/W	R/W	
x	x	x	x	x	x	x	x	

13.4 I/O Port Alternate Functions

Each I/O pin may be configured for an alternate (for example, non-general purpose I/O) function. These alternate functions are selected through various configuration registers, as described in the following sections.

The I/O pin logic for alternate function outputs is slightly different than for alternate function inputs, as shown in Figures 13-2 (output) and 13-3 (input).

Figure 13-2. I/O Pin Logic when Alternate Function is an OUTPUT

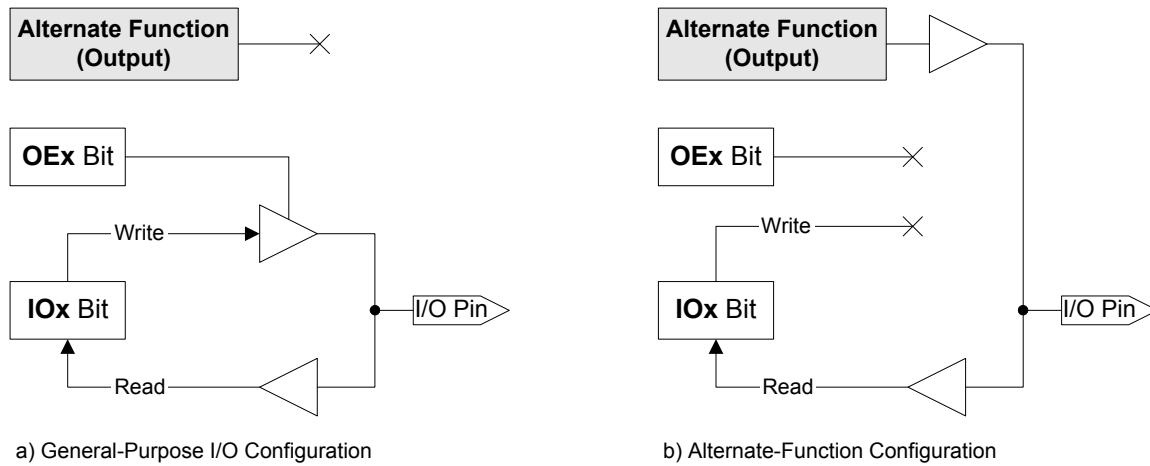

Figure 13-2 shows an I/O pin whose alternate function is always an output.

In Figure 13-2a, the I/O pin is configured for general purpose I/O. In this configuration, the alternate function is disconnected and the pin functions normally.

In Figure 13-2b, the I/O pin is configured as an alternate-function output. In this configuration, the IOx/OEx output buffer is disconnected from the I/O pin, so writes to IOx and OEx have no effect on the I/O pin. ‘Reads’ from IOx, however, continue to work normally; the state of the I/O pin (and, therefore, the state of the alternate function) is always available.

Figure 13-3 shows an I/O pin whose alternate function is always an input.

In Figure 13-3a, the I/O pin is configured for general purpose I/O. There is an important difference between alternate-function inputs and the alternate function outputs shown earlier in Figure 13-2 on page 184: **Note** Alternate-function inputs are never disconnected; they are always listening.

If the alternate function’s interrupt is enabled, signals on the I/O pin may trigger that interrupt. If the pin is to be used only for general purpose I/O, the alternate function’s interrupt must be disabled.

For example, suppose the PE5/INT6 pin is configured for general purpose I/O. Since the INT6 function is an input, the pin signal is also routed to the EZ-USB’s internal INT6 logic. If the INT6 interrupt is enabled, traffic on the PE5 pin trigger an INT6 interrupt. If this is undesirable, the INT6 interrupt should be disabled.

Figure 13-3. I/O Pin Logic when Alternate Function is an INPUT

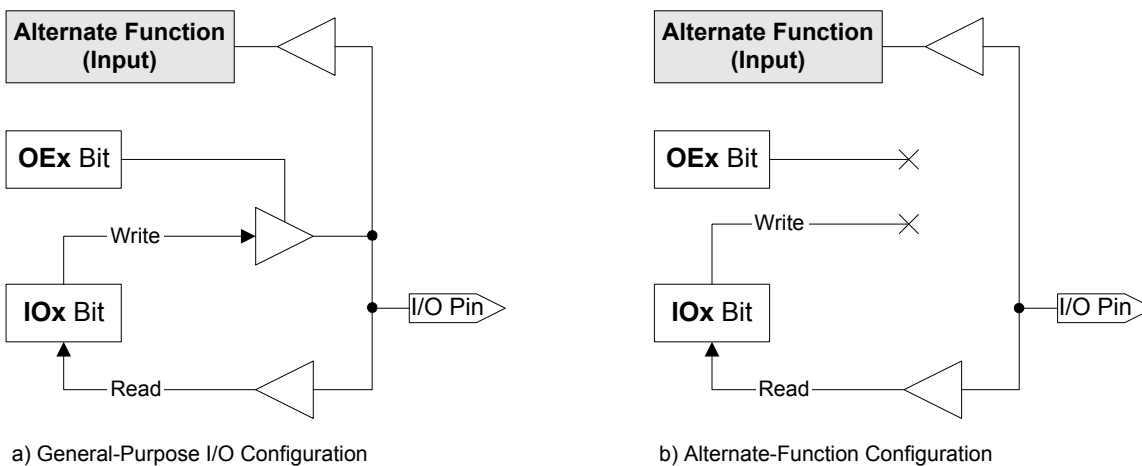

Of course, this side effect can be useful in certain situations. In the case of PE5/INT6, for example, PE5 can trigger an INT6 interrupt even if the I/O pin is configured as an output (for example, OEE.5 = 1), so the EZ-USB's firmware can directly generate external interrupts.

In [Figure 13-3b](#), the I/O pin is configured as an alternate function input. Just as with alternate function outputs, the IOx/OEx output buffer is disconnected from the I/O pin, so writes to IOx and OEx have no effect on the I/O pin. 'Reads'

from IOx, however, continue to work normally; the state of the I/O pin (and therefore, the input to the alternate function) is always available.

13.4.1 Port A Alternate Functions

Alternate functions for the Port A pins are selected by bits in three registers, as shown in [Tables 13-1](#) and [13-2](#).

Table 13-1. Register Bits that Select Port A Alternate Functions

	b7	b6	b5	b4	b3	b2	b1	b0
PORTACFG (0xE670)	FLAGD	SLCS ^[1]	0	0	0	0	INT1	INT0
IFCONFIG (0xE601)	IFCLKSRC	3048MHZ	IFCLKOE	IFCLKPOL	ASYNC	GSTATE	IFCFG1	IFCFG0
WAKEUPCS (0xE682)	WU2	WU	WU2POL	WUPOL	0	DPEN	WU2EN	WUEN

[1] Although the SLCS alternate function is selected by bit 6 of PORTACFG, that function does not appear on pin PA6. Instead, the SLCS function appears on pin PA7 (see [Table 13-2](#)).

Table 13-2. Port A Alternate Function Configuration

Port A Pin	Alternate Function	Alternate Function is Selected By...	Alternate Function is Described in...
PA.0	INT0	PORTACFG.0 = 1	Interrupts chapter on page 59
PA.1	INT1	PORTACFG.1 = 1	Interrupts chapter on page 59
PA.2	SLOE	IFCFG1:0 = 11	Slave FIFOs chapter on page 99
PA.3	WU2 ^[1]	WU2EN = 1	Power Management chapter on page 77
PA.4	FIFOADR0	IFCFG1:0 = 11	Slave FIFOs chapter on page 99
PA.5	FIFOADR1	IFCFG1:0 = 11	Slave FIFOs chapter on page 99
PA.6	PKTEND	IFCFG1:0 = 11	Slave FIFOs chapter on page 99
PA.7	FLAGD ^[2]	PORTACFG.7 = 1	Slave FIFOs chapter on page 99
	SLCS ^[3]	PORTACFG.6 = 1 and IFCFG1:0 = 11	Slave FIFOs chapter on page 99

[1] When PA.3 is configured for alternate function WU2, it continues to function as a general purpose input pin as well. See section [6.4.1 WU2 Pin on page 81](#) for more information.

[2] Although PA.7's alternate function FLAGD is selected via the PORTACFG register, the state of the FLAGD output is undefined unless IFCFG1:0 = 11.

[3] FLAGD takes priority over SLCS if PORTACFG.6 and PORTACFG.7 are both set to '1'.

13.4.2 Port B and Port D Alternate Functions

When IFCFG1 = 1, all eight Port B pins are configured for an alternate configuration (FIFO Data 7:0).

If any of the FIFOs are set to 16 bit mode (via the WORDWIDE bits in the EPxFIFOCFG registers), all eight Port D

pins are also configured for an alternate configuration (FIFO Data 15:8). See Tables 13-3, 13-4, and 13-5.

If all WORDWIDE bits are cleared to '0' (for example, if all four FIFOs are operating in 8 bit mode), the eight Port D pins may be used as general purpose I/O pins even if IFCFG1 = 1.

Table 13-3. Register Bits Which Select Port B and Port D Alternate Functions

	b7	b6	b5	b4	b3	b2	b1	b0
IFCONFIG (0xE601)	IFCLKSRC	3048MHZ	IFCLKOE	IFCLKPOL	ASYNC	GSTATE	IFCFG1	IFCFG0
EP2FIFOCFG (0xE618)	0	INFM2	OEP2	AUTOOUT	AUTOIN	ZEROLENIN	0	WORDWIDE
EP4FIFOCFG (0xE619)	0	INFM4	OEP4	AUTOOUT	AUTOIN	ZEROLENIN	0	WORDWIDE
EP6FIFOCFG (0xE61A)	0	INFM6	OEP6	AUTOOUT	AUTOIN	ZEROLENIN	0	WORDWIDE
EP8FIFOCFG (0xE61B)	0	INFM8	OEP8	AUTOOUT	AUTOIN	ZEROLENIN	0	WORDWIDE

Table 13-4. Port B Alternate-Function Configuration

Port B Pin	Alternate Function	Alternate Function is Selected By...	Alternate Function is Described in...
PB.7:0	FD[7:0]	IFCFG1 = 1	Slave FIFOs chapter on page 99

Table 13-5. Port D Alternate-Function Configuration

Port D Pin	Alternate Function	Alternate Function is Selected By...	Alternate Function is Described in...
PD.7:0	FD[15:8]	IFCFG1 = 1 and any WORDWIDE bit = 1	Slave FIFOs chapter on page 99

13.4.3 Port C Alternate Functions

Each Port C pin may be individually configured for an alternate function by setting a bit in the PORTCCFG register, as shown in Tables 13-6 and 13-7.

Table 13-6. Register Bits That Select Port C Alternate Functions

	b7	b6	b5	b4	b3	b2	b1	b0
PORTCCFG (0xE671)	GPIFA7	GPIFA6	GPIFA5	GPIFA4	GPIFA3	GPIFA2	GPIFA1	GPIFA0

Table 13-7. Port C Alternate Function Configuration

Port C Pin	Alternate Function	Alternate Function is Selected By...	Alternate Function is Described in...
PC.0	GPIFA0 ^[1]	PORTCCFG.0 = 1	General Programmable Interface chapter on page 121.
PC.1	GPIFA1 ^[1]	PORTCCFG.1 = 1	General Programmable Interface chapter on page 121.
PC.2	GPIFA2 ^[1]	PORTCCFG.2 = 1	General Programmable Interface chapter on page 121.
PC.3	GPIFA3 ^[1]	PORTCCFG.3 = 1	General Programmable Interface chapter on page 121.
PC.4	GPIFA4 ^[1]	PORTCCFG.4 = 1	General Programmable Interface chapter on page 121.
PC.5	GPIFA5 ^[1]	PORTCCFG.5 = 1	General Programmable Interface chapter on page 121.
PC.6	GPIFA6 ^[1]	PORTCCFG.6 = 1	General Programmable Interface chapter on page 121.
PC.7	GPIFA7 ^[1]	PORTCCFG.7 = 1	General Programmable Interface chapter on page 121.

[1] Although the Port C alternate functions GPIFA0:7 are selected via the PORTCCFG register, the states of the GPIFA0:7 outputs are undefined unless IFCFG1:0 = 10.

13.4.4 Port E Alternate Functions

Each Port E pin may be individually configured for an alternate function by setting a bit in the PORTECFG register.

If the GSTATE bit in the IFCONFIG register is set to '1', the PE.2:0 pins are automatically configured as GPIF Status pins GSTATE[2:0], regardless of the PORTECFG.2:0 settings. In other words, GSTATE overrides PORTECFG.2:0. See Tables 13-8 and 13-9.

Table 13-8. Register Bits That Select Port E Alternate Functions

	b7	b6	b5	b4	b3	b2	b1	b0
PORTECFG (0xE671)	GPIFA8	T2EX	INT6	RXD1OUT	RXD0OUT	T2OUT	T1OUT	T0OUT
IFCONFIG (0xE601)	IFCLKSRC	3048MHZ	IFCLKOE	IFCLKPOL	ASYNC	GSTATE	IFCFG1	IFCFG0

Table 13-9. Port E Alternate-Function Configuration

Port E Pin	Alternate Function	Alternate Function is Selected By...	Alternate Function is Described in...
PE.0	T0OUT ^[1,3]	PORTECFG.0 = 1 and GSTATE = 0	Timers/Counters and Serial Interface chapter on page 193
PE.1	T1OUT ^[1,3]	PORTECFG.1 = 1 and GSTATE = 0	Timers/Counters and Serial Interface chapter on page 193
PE.2	T2OUT ^[1]	PORTECFG.2 = 1 and GSTATE = 0	Timers/Counters and Serial Interface chapter on page 193
PE.3	RXD0OUT	PORTECFG.3 = 1	Timers/Counters and Serial Interface chapter on page 193
PE.4	RXD1OUT	PORTECFG.4 = 1	Timers/Counters and Serial Interface chapter on page 193
PE.5	INT6	PORTECFG.5 = 1	Interrupts chapter on page 59
PE.6	T2EX	PORTECFG.6 = 1	Timers/Counters and Serial Interface chapter on page 193
PE.7	GPIFA8 ^[2]	PORTECFG.7 = 1	General Programmable Interface chapter on page 121

[1] If GSTATE is set to '1', these settings are overridden and PE.2:0 are all automatically configured as GPIF Status pins (See [General Programmable Interface chapter on page 121](#)).

[2] Although the PE.7 alternate function GPIFA8 is selected via the PORTECFG register, the state of the GPIFA8 output is undefined unless IFCFG1:0 = 10.

[3] Alternate function for PE.1:0 not available for CY7C68015A and CY68016A.

Table 13-10. IFCFG Selection of Port I/O Pin Functions

IFCFG1:0 = 00 (Ports)	IFCFG1:0 = 10 (GPIF Master)	IFCFG1:0 = 11 (Slave FIFO)
PD7	FD[15]	FD[15]
PD6	FD[14]	FD[14]
PD5	FD[13]	FD[13]
PD4	FD[12]	FD[12]
PD3	FD[11]	FD[11]
PD2	FD[10]	FD[10]
PD1	FD[9]	FD[9]
PD0	FD[8]	FD[8]
PB7	FD[7]	FD[7]
PB6	FD[6]	FD[6]
PB5	FD[5]	FD[5]
PB4	FD[4]	FD[4]
PB3	FD[3]	FD[3]
PB2	FD[2]	FD[2]
PB1	FD[1]	FD[1]
PB0	FD[0]	FD[0]
INT0# / PA0	INT0# / PA0	INT0# / PA0
INT1# / PA1	INT1# / PA1	INT1# / PA1

Table 13-10. IFCFG Selection of Port I/O Pin Functions (continued)

IFCFG1:0 = 00 (Ports)	IFCFG1:0 = 10 (GPIF Master)	IFCFG1:0 = 11 (Slave FIFO)
PA2	PA2	SLOE
WU2 / PA3	WU2 / PA3	WU2 / PA3
PA4	PA4	FIFOADR0
PA5	PA5	FIFOADR1
PA6	PA6	PKTEND
PA7	PA7	PA7 / FLAGD / SLCS#
PC7:0	PC7:0	PC7:0
PE7:0	PE7:0	PE7:0
Note Signals shown in bold type do not change with IFCFG; they are shown for completeness.		

13.5 I2C Bus Controller

The I2C bus controller uses the SCL (Serial Clock) and SDA (Serial Data) pins, and performs two functions:

- General purpose interfacing to I2C peripherals
- Boot loading from a serial EEPROM

Note Pull up resistors are required on the SDA and SCL lines, **even if nothing else is connected to the I2C bus**. Each line must be pulled up to Vcc through a 2.2K ohm resistor.

The bus frequency defaults to approximately 100 kHz for compatibility, and it can be configured to run at 400 kHz for devices that support the higher speed.

13.5.1 Interfacing to I2C Peripherals

Figure 13-4 illustrates the waveforms for an I2C transfer. SCL and SDA are open drain EZ-USB pins which must be pulled up to Vcc with external resistors. The EZ-USB is a bus master only, meaning that it generates clock pulses on SCL. Once the master drives SCL low, external slave devices can hold SCL low to extend clock-cycle times.

Serial data is permitted to change state only while SCL is low, and must be valid while SCL is high. Two exceptions to this rule are the 'start' and 'stop' conditions. A 'start' condition is defined as a high-to-low transition on SDA while SCL is high, and a 'stop' condition is defined as a low-to-high transition on SDA while SCL is high. Data is sent MSB first. During the last bit time (clock #9 in Figure 13-4), the transmitting device floats the SDA line to allow the receiving device to acknowledge the transfer by pulling SDA low.

13.5.1.1 Multiple Bus Masters

The EZ-USB acts only as a bus master, never as a slave. Conflicts with a second master can be detected, however,

by checking for BERR=1 (see section 13.5.2.1 I2CS Register on page 190).

Each peripheral (slave) device on the I2C bus has a unique address. The first byte of an I2C transaction contains the address of the desired peripheral. Figure 13-5 shows the format for this first byte, which is sometimes called a control byte.

The EZ-USB sends the bit sequence shown in Figure 13-5 to select the peripheral at a particular address, to establish the transfer direction (using $\overline{R/\overline{W}}$), and to determine if the peripheral is present by testing for \overline{ACK} .

The four most significant bits (SA3:0) are the peripheral chip's slave address. I2C devices are internally hardwired to pre-assigned slave addresses by device type. EEPROMs, for instance, are assigned slave address 1010. The next three bits (DA2:0) usually reflect the states of the device's address pins. A device with three address pins can be strapped to one of eight distinct addresses, which allows, for example, up to eight serial EEPROMs to be individually addressed on one I2C bus.

The eighth bit ($\overline{R/\overline{W}}$) sets the direction for the data transfer to follow (1 = master read, 0 = master write). Most address transfers are followed by one or more data transfers, with the 'stop' condition generated after the last data byte is transferred.

In Figure 13-5, the master clocks the 7 bit slave/device address out on SDA, then sets the $\overline{R/\overline{W}}$ bit high at clock 8, indicating that a read transfer follows this address byte. At clock 9, the master releases SDA and treats it as an input; the peripheral device responds to its address by asserting \overline{ACK} . At clock 10, the master begins to clock in data from the slave on the SDA pin.

Figure 13-4. General I2C Transfer

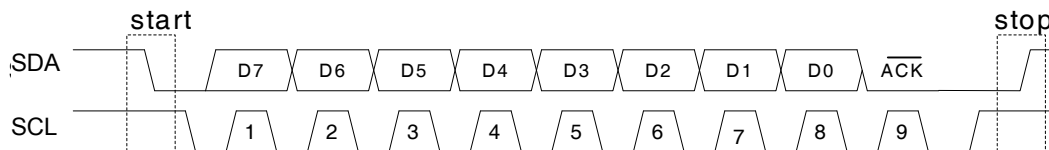

Figure 13-5. Addressing an I2C Peripheral



13.5.2 Registers

The three registers shown in this section are used to conduct transfers over the I2C bus.

13.5.2.1 I2CS Register

I2CS		I2C Bus Control and Status						E678
b7	b6	b5	b4	b3	b2	b1	b0	
START	STOP	LASTRD	ID1	ID0	BERR	ACK	DONE	
R/W	R/W	R/W	R	R	R	R	R	
0	0	0	x	x	0	0	0	

Bit 7: START. When START = 1, the next write to I2DAT generates a 'start' condition followed by the byte of data written to I2DAT. The START bit is automatically cleared to 0 after the ACK interval (clock 9 in [Figure 13-4 on page 189](#)). START is a control bit.

Bit 6: STOP. When STOP = 1 after the ACK interval (clock 9 in [Figure 13-4 on page 189](#)), a 'stop' condition is generated. STOP may be set by firmware at any time before, during, or after the 9-bit data transaction. STOP is automatically cleared after the 'stop' condition is generated. STOP is a control bit.

An interrupt request is available to signal that the stop condition is complete; see STOPIE, below.

Bit 5: LASTRD. An I2C master reads data by floating the SDA line and issuing clock pulses on the SCL line. After every eight bits, the master drives SDA low for one clock to indicate ACK. To signal the last byte of a multi-byte transfer, the master floats SDA at ACK time to instruct the slave to stop sending. LASTRD is a control bit.

When LASTRD = 1 at ACK time, the EZ-USB floats the SDA line. The LASTRD bit may be set at any time before or during the data transfer; it is automatically cleared after the ACK interval.

Note Setting LASTRD does not automatically generate a 'stop' condition. At the end of a read transfer, the STOP bit should also be set.

Bits 3 and 4: ID1, ID0. These bits are automatically set by the boot loader to indicate the Boot EEPROM addressing mode. They are normally used only for debug purposes; for full details, see section [13.6 EEPROM Boot Loader on page 192](#).

Bit 2: BERR. This bit indicates a bus error. BERR=1 indicates that there was bus contention during the preceding transfer, which results when an outside device drives the bus when it should not, or when another bus master wins arbitration and takes control of the bus. BERR is a status bit.

When a bus error is detected, the EZ-USB immediately cancels its current transfer, floats the SCL and SDA lines, and sets DONE and BERR. BERR remains set until it is updated at the next ACK interval. The I2C master does not drive SCL

till BERR is reset. If the bus error causes the master to detect bus contention and slave to be stuck in the middle of a transfer. Then there is no in-built contention resolution method to workaround this deadlock. If there is a possibility of this condition then the design must implement a method of resetting the slave or clocking the slave till the next ACK.

Note DONE is set with BERR only when bus contention occurs **during** a transfer. If BERR is set and the bus is still busy when firmware attempts to restart a transfer, that transfer request is ignored and the DONE flag is **not** set. If contention is expected, therefore, EZ-USB firmware should incorporate a timeout to test for this condition. See Steps 1 and 3 of [Section 13.5.3](#) and [Section 13.5.4](#).

Bit 1: ACK. During the ninth clock of a write transfer, the slave indicates reception of the byte by driving SDA low to acknowledge the byte it just received. The EZ-USB floats SDA during this time, samples the SDA line, and updates the ACK bit with the complement of the detected value: ACK = 1 indicates that the slave acknowledged the transfer, and ACK = 0 indicates the slave did not. ACK is a status bit.

The ACK bit is only meaningful after a write transfer. After a read transfer, its state should be ignored.

Bit 0: DONE. The EZ-USB sets this bit whenever it completes a byte transfer. The EZ-USB also generates an interrupt request when it sets the DONE bit. The DONE bit is automatically cleared when the I2DAT register is read or written, and the interrupt request bit is automatically cleared by reading or writing the I2CS or I2DAT registers (or by clearing EXIF.5 to 0). DONE is a status bit.

For additional information, refer to the [I2CS register on page 278](#).

13.5.2.2 I2CDAT Register

I2CDAT								I2C Bus Data								E679															
b7	b6	b5	b4	b3	b2	b1	b0	D7	D6	D5	D4	D3	D2	D1	D0	R/W	R/W	R/W	R/W	R/W	R/W	R/W	R/W	x	x	x	x	x	x	x	x

Writing to I2CDAT initiates a write transfer on the I2C bus; the value written to I2CDAT is then transferred. Reading from I2CDAT retrieves the data that was transferred in the previous read transfer and (with one exception) initiates another read transfer. To retrieve data from the previous read transfer

without initiating another transfer, I2CDAT must be read during the generation of the 'stop' condition. See Step 13 of section 13.5.4 Receiving Data on page 191 for details. For additional information, refer to the I2CDAT register on page 280.

13.5.2.3 I2CTL Register

I2CTL								I2C Bus Mode								E67A															
b7	b6	b5	b4	b3	b2	b1	b0	0	0	0	0	0	0	STOPIE	400KHZ	R	R	R	R	R	R	R/W	R/W	0	0	0	0	0	0	0	0

I2CTL configures the bus. Data is transferred to and from the bus through the I2DAT register. The I2CS register controls the transfers and reports various status conditions.

Bit 1: STOPIE. Setting this bit to '1' enables the STOP bit Interrupt Request, which is activated when the STOP bit makes a 1-to-0 transition (for example, when generation of a 'stop' condition is complete). STOPIE is a control bit.

Bit 0: 400KHZ. When this bit is at its default value of '0', SCL is driven at approximately 100 kHz. Setting this bit to '1' causes the EZ-USB to drive SCL at approximately 400 kHz. 400KHZ is a control bit.

For additional information, refer to the I2CTL register on page 281.

13.5.3 Sending Data

To send a multiple byte data record, follow these steps:

1. Set START=1. If BERR=1, start timer. The timeout should be at least as long as the longest expected Start-to-Stop interval on the bus.
2. Write the 7-bit peripheral address and the direction bit (0 for a write) to I2DAT.
3. Wait for DONE=1 or for timer to expire*. If BERR=1, go to step 1.
4. If ACK=0, go to step 9.
5. Load I2DAT with a data byte.
6. Wait for DONE=1*. If BERR=1, go to step 1.
7. If ACK=0, go to step 9.
8. Repeat steps 5-7 for each byte until all bytes have been transferred.
9. Set STOP=1. Wait for STOP = 0 before initiating another transfer.

13.5.4 Receiving Data

To read a multiple-byte data record, follow these steps:

1. Set START=1. If BERR = 1, start timer. The timeout should be at least as long as the longest expected Start-to-Stop interval on the bus.
2. Write the 7-bit peripheral address and the direction bit (1 for a read) to I2DAT.
3. Wait for DONE=1 or for timer to expire*. If BERR=1, go to step 1.
4. If ACK=0, set STOP=1 and go to step 15.
5. Read I2DAT to initiate the first burst of nine SCL pulses to clock in the first byte from the slave. Discard the value that was read from I2DAT.
6. Wait for DONE=1. If BERR=1, go to step 1.
7. Read the just-received byte of data from I2DAT. This read also initiates the next read transfer.
8. Repeat steps 6 and 7 for each byte until ready to read the second-to-last byte.
9. Wait for DONE=1. If BERR=1, go to step 1.

10. Before reading the second-to-last I2DAT byte, set LAS-TRD=1.
11. Read the second-to-last byte from I2DAT. With LAS-TRD=1, this initiates the final byte read on the bus.
12. Wait for DONE=1. If BERR=1, go to step 1.
13. Set STOP=1.
14. Read the final byte from I2DAT immediately (the next instruction) after setting the STOP bit. By reading I2DAT *while* the 'stop' condition is being generated, the just-received data byte is retrieved *without* initiating an extra read transaction (nine more SCL pulses) on the I2Cbus.
15. Wait for STOP = 0 before initiating another transfer.

13.6 EEPROM Boot Loader

Whenever the EZ-USB is taken out of reset via the reset pin, its boot loader checks for the presence of an EEPROM on the I2C bus. If an EEPROM is detected, the loader reads the first EEPROM byte to determine how to enumerate. The various enumeration modes are described in the [Enumeration and ReNumeration™ chapter on page 51](#).

The EZ-USB boot loader supports two I2C EEPROM types:

- EEPROMs with slave address 1010 that use an 8-bit internal address (for example, 24LC00, 24LC01/B, 24LC02/B).
- EEPROMs with slave address 1010 that use a 16-bit internal address (for example, 24AA64, 24LC128, 24AA256).

EEPROMs with densities up to 256 bytes require only a single address byte; larger EEPROMs require two address bytes. The EZ-USB must determine which EEPROM type is connected — one or two address bytes — so that it can properly read the EEPROM.

The EZ-USB uses the EEPROM device-address pins A2, A1, and A0 to determine whether to send out one or two bytes of address. As shown in [Table 13-11](#), single byte address EEPROMs must be strapped to address 000, while double byte address EEPROMs must be strapped to address 001.

Table 13-11. Strap Boot EEPROM Address Lines to These Values

Bytes	Example EEPROM	A2	A1	A0
16	24LC00 ^[1]	N/A	N/A	N/A
128	24LC01	0	0	0
256	24LC02	0	0	0
4K	24LC32	0	0	1
8K	24LC64	0	0	1
16K	24LC128	0	0	1

[1] This EEPROM does not have device-address pins.

Additional EEPROM devices can be attached to the I2Cbus for general purpose use, as long as they are strapped for device addresses other than 000 or 001.

Note Many single byte Address EEPROM's are special cases, because the EEPROM responds to all eight device addresses. If one of these EEPROM's is used for boot loading, no other EEPROMs may share the bus. Consult your EEPROM data sheet for details

After determining whether a one or two byte address EEPROM is attached, the EZ-USB reports its results in the ID1 and ID0 bits, as shown in [Table 13-12](#).

Table 13-12. Results of Power-On_Reset EEPROM Test

ID1	ID0	Meaning
0	0	No EEPROM detected
0	1	One byte address load EEPROM detected
1	0	Two byte address load EEPROM detected
1	1	Not used

Note The EZ-USB does not check for bus contention during the bootloading process; if another I2C master is sharing the bus, that master must not attempt to initiate any transfers while the EZ-USB bootloader is running.

14. Timers/Counters and Serial Interface



14.1 Introduction

The EZ-USB's timer/counters and serial interface are very similar to the standard 8051, with some differences and enhancements. This chapter provides technical information on configuring and using the timer/counters and serial interface.

14.2 Timers/Counters

The EZ-USB includes three timer/counters (Timer 0, Timer 1, and Timer 2). Each timer/counter can operate either as a timer with a clock rate based on the EZ-USB's internal clock (CLKOUT) or as an event counter clocked by the T0 pin (Timer 0), T1 pin (Timer 1), or the T2 pin (Timer 2). Timers 1 and 2 may be used for baud clock generation for the serial interface (see section 14.3 Serial Interface on page 201 for details of the serial interface).

Note The EZ-USB can be configured to operate at 12, 24, or 48 MHz. In timer mode, the timer/counters run at the same speed as the EZ-USB, and they are not affected by the CLKOE and CLKINV configuration bits (CPUCS.1 and CPUCS.2).

Each timer/counter consists of a 16 bit register that is accessible to software as two SFRs.

- Timer 0 TH0 and TL0
- Timer 1 TH1 and TL1
- Timer 2 TH2 and TL2

14.2.1 803x/805x Compatibility

The implementation of the timers/counters is similar to that of the Dallas Semiconductor DS80C320. Table 14-1 summarizes the differences in timer/counter implementation between the Intel 8051, the Dallas Semiconductor DS80C320, and the EZ-USB.

Table 14-1. Timer/Counter Implementation Comparison

Feature	Intel 8051	Dallas DS80C320	EZ-USB
Number of timers	2	3	3
Timer 0/1 overflow available as output signals	No	No	Yes; T0OUT, T1OUT (one CLKOUT pulse)
Timer 2 output enable	n/a	Yes	Yes
Timer 2 down-count enable	n/a	Yes	No
Timer 2 overflow available as output signal	n/a	Yes	Yes; T2OUT (one CLKOUT pulse)

14.2.2 Timers 0 and 1

Timers 0 and 1 operate in four modes, as controlled through the TMOD SFR (Table 14-2 on page 195) and the TCON SFR (Table 14-3 on page 195). The four modes are:

- 13 bit timer/counter (mode 0)
- 16 bit timer/counter (mode 1)
- 8 bit counter with auto-reload (mode 2)
- Two 8 bit counters (mode 3, Timer 0 only)

14.2.2.1 Mode 0, 13 Bit Timer/Counter— Timer 0 and Timer 1

Mode 0 operation is illustrated in Figure 14-1.

In mode 0, the timer is configured as a 13 bit counter that uses bits 0-4 of TL0 (or TL1) and all 8 bits of TH0 (or TH1). The timer enable bit (TR0/TR1) in the TCON SFR starts the timer. The C/\bar{T} Bit selects the timer/counter clock source: either CLKOUT or the T0/T1 pins.

The timer counts transitions from the selected source as long as the GATE Bit is 0, or the GATE Bit is 1 and the corresponding interrupt pin ($\overline{INT0}$ or $\overline{INT1}$) is 1.

When the 13 bit count increments from 0x1FFF (all ones), the counter rolls over to all zeros, the TF0 (or TF1) Bit is set in the TCON SFR, and the T0OUT (or T1OUT) pin goes high for one clock cycle.

Ignore the upper 3 bits of TL0 (or TL1) because they are indeterminate in mode 0.

Figure 14-1. Timer 0/1 - Modes 0 and 1

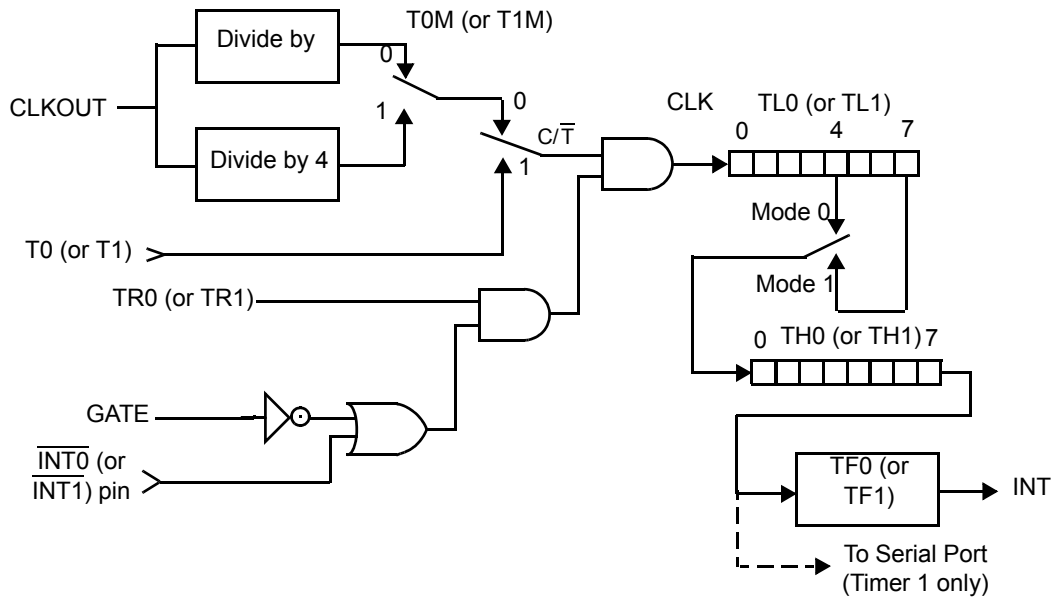

14.2.2.2 Mode 1, 16 Bit Timer/Counter — Timer 0 and Timer 1

In mode 1, the timer is configured as a 16 bit counter. As illustrated in [Figure 14-1 on page 194](#), all 8 bits of the LSB Register (TL0 or TL1) are used. The counter rolls over to all zeros when the count increments from 0xFFFF. Otherwise, mode 1 operation is the same as mode 0.

Table 14-2. TMOD Register — SFR 0x89

Bit	Function															
TMOD.7	GATE1 - Timer 1 gate control. When GATE1 = 1, Timer 1 will clock only when $\overline{\text{INT1}} = 1$ and TR1 (TCON.6) = 1. When GATE1 = 0, Timer 1 will clock only when TR1 = 1, regardless of the state of INT1.															
TMOD.6	C/T1 - Counter/Timer select. When $\overline{\text{C/T1}} = 0$, Timer 1 is clocked by CLKOUT/4 or CLKOUT/12, depending on the state of T1M (CKCON.4). When $\overline{\text{C/T1}} = 1$, Timer 1 is clocked by high-to-low transitions on the T1 pin.															
TMOD.5	M1 - Timer 1 mode select bit 1.															
TMOD.4	M0 - Timer 1 mode select bit 0. <table border="1"> <thead> <tr> <th>M1</th> <th>M0</th> <th>Mode</th> </tr> </thead> <tbody> <tr> <td>0</td> <td>0</td> <td>Mode 0: 13 bit counter</td> </tr> <tr> <td>0</td> <td>1</td> <td>Mode 1: 16 bit counter</td> </tr> <tr> <td>1</td> <td>0</td> <td>Mode 2: 8 bit counter with auto-reload</td> </tr> <tr> <td>1</td> <td>1</td> <td>Mode 3: Timer 1 stopped</td> </tr> </tbody> </table>	M1	M0	Mode	0	0	Mode 0: 13 bit counter	0	1	Mode 1: 16 bit counter	1	0	Mode 2: 8 bit counter with auto-reload	1	1	Mode 3: Timer 1 stopped
M1	M0	Mode														
0	0	Mode 0: 13 bit counter														
0	1	Mode 1: 16 bit counter														
1	0	Mode 2: 8 bit counter with auto-reload														
1	1	Mode 3: Timer 1 stopped														
TMOD.3	GATE0 - Timer 0 gate control. When GATE0 = 1, Timer 0 will clock only when $\overline{\text{INT0}} = 1$ and TR0 (TCON.4) = 1. When GATE0 = 0, Timer 0 will clock only when TR0 = 1, regardless of the state of INT0.															
TMOD.2	C/T0 - Counter/Timer select. When $\overline{\text{C/T0}} = 0$, Timer 0 is clocked by CLKOUT/4 or CLKOUT/12, depending on the state of T0M (CKCON.3). When $\overline{\text{C/T0}} = 1$, Timer 0 is clocked by high-to-low transitions on the T0 pin.															
TMOD.1	M1 - Timer 0 mode select bit 1.															
TMOD.0	M0 - Timer 0 mode select bit 0. <table border="1"> <thead> <tr> <th>M1</th> <th>M0</th> <th>Mode</th> </tr> </thead> <tbody> <tr> <td>0</td> <td>0</td> <td>Mode 0: 13 bit counter</td> </tr> <tr> <td>0</td> <td>1</td> <td>Mode 1: 16 bit counter</td> </tr> <tr> <td>1</td> <td>0</td> <td>Mode 2: 8 bit counter with auto-reload</td> </tr> <tr> <td>1</td> <td>1</td> <td>Mode 3: Two 8 bit counters</td> </tr> </tbody> </table>	M1	M0	Mode	0	0	Mode 0: 13 bit counter	0	1	Mode 1: 16 bit counter	1	0	Mode 2: 8 bit counter with auto-reload	1	1	Mode 3: Two 8 bit counters
M1	M0	Mode														
0	0	Mode 0: 13 bit counter														
0	1	Mode 1: 16 bit counter														
1	0	Mode 2: 8 bit counter with auto-reload														
1	1	Mode 3: Two 8 bit counters														

Table 14-3. TCON Register — SFR 0x88

Bit	Function
TCON.7	TF1 - Timer 1 overflow flag. Set to 1 when the Timer 1 count overflows; automatically cleared when the EZ-USB vectors to the interrupt service routine.
TCON.6	TR1 - Timer 1 run control. 1 = Enable counting on Timer 1.
TCON.5	TF0 - Timer 0 overflow flag. Set to 1 when the Timer 0 count overflows; automatically cleared when the EZ-USB vectors to the interrupt service routine.
TCON.4	TR0 - Timer 0 run control. 1 = Enable counting on Timer 0.
TCON.3	IE1 - Interrupt 1 edge detect. If external interrupt 1 is configured to be edge-sensitive (IT1 = 1), IE1 is set when a negative edge is detected on the $\overline{\text{INT1}}$ pin and is automatically cleared when the EZ-USB vectors to the corresponding interrupt service routine. In this case, IE1 can also be cleared by software. If external interrupt 1 is configured to be level-sensitive (IT1 = 0), IE1 is set when the $\overline{\text{INT1}}$ pin is 0 and automatically cleared when the $\overline{\text{INT1}}$ pin is 1. In level-sensitive mode, software cannot write to IE1.
TCON.2	IT1 - Interrupt 1 type select. $\overline{\text{INT1}}$ is detected on falling edge when IT1 = 1; $\overline{\text{INT1}}$ is detected as a low level when IT1 = 0.
TCON.1	IE0 - Interrupt 0 edge detect. If external interrupt 0 is configured to be edge-sensitive (IT0 = 1), IE0 is set when a negative edge is detected on the $\overline{\text{INT0}}$ pin and is automatically cleared when the EZ-USB vectors to the corresponding interrupt service routine. In this case, IE0 can also be cleared by software. If external interrupt 0 is configured to be level-sensitive (IT0 = 0), IE0 is set when the $\overline{\text{INT0}}$ pin is 0 and automatically cleared when the $\overline{\text{INT0}}$ pin is 1. In level-sensitive mode, software cannot write to IE0.
TCON.0	IT0 - Interrupt 0 type select. $\overline{\text{INT0}}$ is detected on falling edge when IT0 = 1; $\overline{\text{INT0}}$ is detected as a low level when IT0 = 0.

Figure 14-2. Timer 0/1 - Mode 2

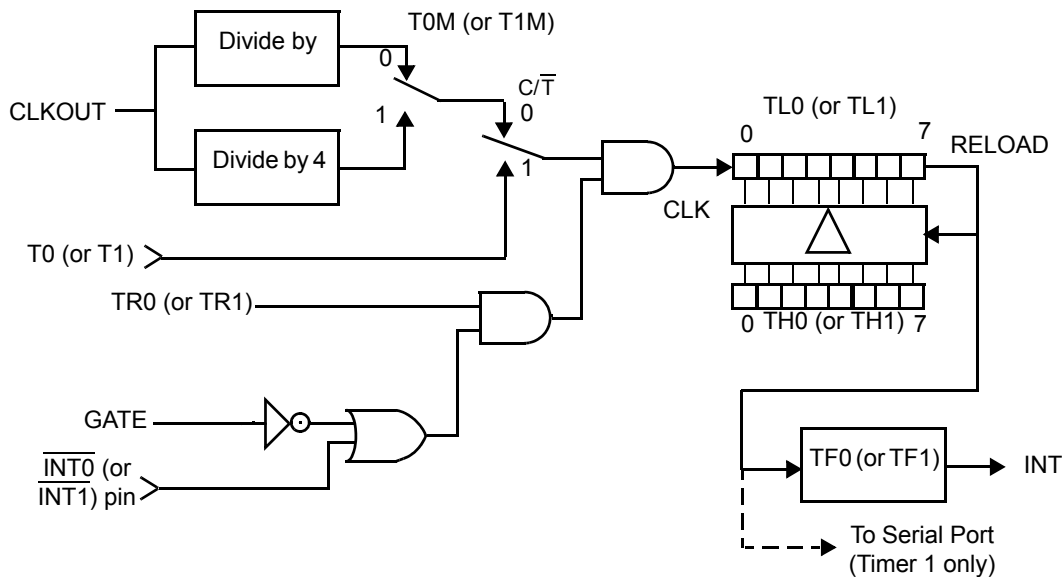

14.2.2.3 Mode 2, 8 Bit Counter with Auto-Reload — Timer 0 and Timer 1

In mode 2, the timer is configured as an 8 bit counter, with automatic reload of the start value on overflow. TL0 (or TL1) is the counter, and TH0 (or TH1) stores the reload value.

As illustrated in [Figure 14-2](#), mode 2 counter control is the same as for mode 0 and mode 1. When TL0/1 increments from 0xFF, the value stored in TH0/1 is reloaded into TL0/1.

14.2.2.4 Mode 3, Two 8 Bit Counters — Timer 0 Only

In mode 3, Timer 0 operates as two 8 bit counters. Selecting mode 3 for Timer 1 simply stops Timer 1.

As shown in [Figure 14-3 on page 197](#), TL0 is configured as an 8 bit counter controlled by the normal Timer 0 control bits. TL0 can either count CLKOUT cycles (divided by 4 or by 12) or high-to-low transitions on the T0 pin, as determined by the C/T Bit. The GATE function can be used to give counter enable control to the INT0 pin.

TH0 functions as an independent 8 bit counter. However, TH0 can only count CLKOUT cycles (divided by 4 or by 12). The Timer 1 control and flag bits (TR1 and TF1) are used as the control and flag bits for TH0.

When Timer 0 is in mode 3, Timer 1 has limited usage because Timer 0 uses the Timer 1 control bit (TR1) and interrupt flag (TF1). Timer 1 can still be used for baud rate generation and the Timer 1 count values are still available in the TL1 and TH1 Registers.

Control of Timer 1 when Timer 0 is in mode 3 is through the Timer 1 mode bits. To turn Timer 1 on, set Timer 1 to mode 0, 1, or 2. To turn Timer 1 off, set it to mode 3. The Timer 1 C/T Bit and T1M Bit are still available to Timer 1. Therefore, Timer 1 can count CLKOUT/4, CLKOUT/12, or high-to-low transitions on the T1 pin. The Timer 1 GATE function is also available when Timer 0 is in mode 3.

Figure 14-3. Timer 0 - Mode 3

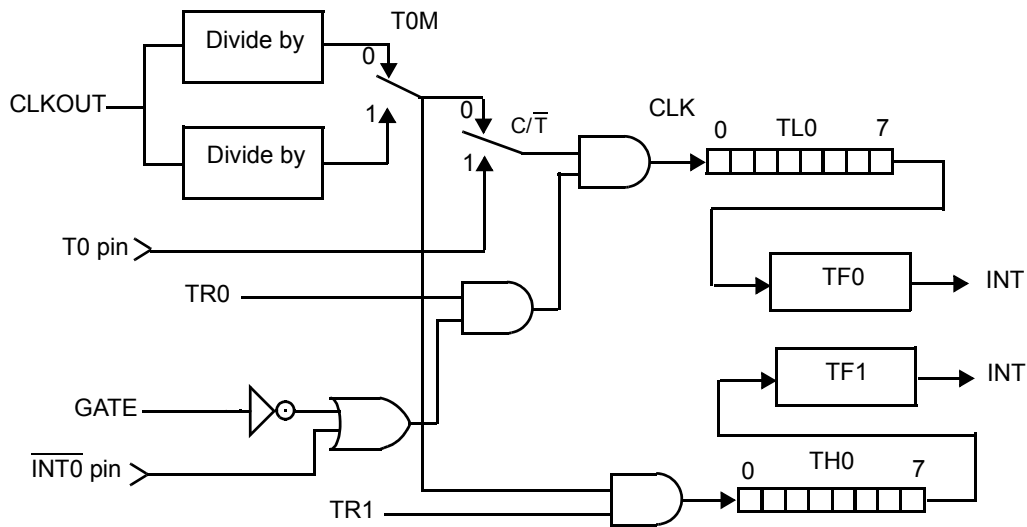

14.2.3 Timer Rate Control

By default, the EZ-USB timers increment every 12 CLKOUT cycles, just as in the standard 8051. Using this default rate allows existing application code with real-time dependencies, such as baud rate, to operate properly.

Applications that require fast timing can set the timers to increment every four CLKOUT cycles instead, by setting bits in the Clock Control Register (CKCON) at SFR location 0x8E. (See Table 14-4).

Each timer's rate can be set independently. These settings have no effect in counter mode.

Table 14-4. CKCON (SFR 0x8E) Timer Rate Control Bits

Bit	Function
CKCON.5	T2M - Timer 2 clock select. When T2M = 0, Timer 2 uses CLKOUT/12 (for compatibility with standard 8051); when T2M = 1, Timer 2 uses CLKOUT/4. This bit has no effect when Timer 2 is configured for baud rate generation.
CKCON.4	T1M - Timer 1 clock select. When T1M = 0, Timer 1 uses CLKOUT/12 (for compatibility with standard 8051); when T1M = 1, Timer 1 uses CLKOUT/4.
CKCON.3	T0M - Timer 0 clock select. When T0M = 0, Timer 0 uses CLKOUT/12 (for compatibility with standard 8051); when T0M = 1, Timer 0 uses CLKOUT/4.

14.2.4 Timer 2

Timer 2 runs only in 16 bit mode and offers several capabilities not available with Timers 0 and 1. The modes available for Timer 2 are:

- 16 bit timer/counter
- 16 bit timer with capture
- 16 bit timer/counter with auto-reload
- Baud rate generator

The SFRs associated with Timer 2 are:

- T2CON (SFR 0xC8) Timer/Counter 2 Control register, (see Table 14-5 on page 198).
- RCAP2L (SFR 0xCA) Captures the TL2 value when Timer 2 is configured for capture mode, or as the LSB of the 16 bit reload value when Timer 2 is configured for auto-reload mode.
- RCAP2H (SFR 0xCB) Captures the TH2 value when Timer 2 is configured for capture mode, or as the MSB of the 16 bit reload value when Timer 2 is configured for auto-reload mode.
- TL2 (SFR 0xCC) The lower eight bits of the 16 bit count.
- TH2 (SFR 0xCD) The upper eight bits of the 16 bit count.

Table 14-5. T2CON Register — SFR 0xC8

Bit	Function
T2CON.7	TF2 - Timer 2 overflow flag. Hardware sets TF2 when the Timer 2 overflows from 0xFFFF. TF2 must be cleared to 0 by the software. TF2 is only set to a '1' if RCLK and TCLK are both cleared to '0'. Writing a one to TF2 forces a Timer 2 interrupt if enabled.
T2CON.6	EXF2 - Timer 2 external flag. Hardware sets EXF2 when a reload or capture is caused by a high-to-low transition on the T2EX pin, and EXEN2 is set. EXF2 must be cleared to '0' by software. Writing a one to EXF2 forces a Timer 2 interrupt, if enabled.
T2CON.5	RCLK - Receive clock flag. Determines whether Timer 1 or Timer 2 is used for Serial Port 0 timing of received data in serial mode 1 or 3. RCLK=1 selects Timer 2 overflow as the receive clock; RCLK=0 selects Timer 1 overflow as the receive clock.
T2CON.4	TCLK - Transmit clock flag. Determines whether Timer 1 or Timer 2 is used for Serial Port 0 timing of transmit data in serial mode 1 or 3. TCLK=1 selects Timer 2 overflow as the transmit clock; TCLK=0 selects Timer 1 overflow as the transmit clock.
T2CON.3	EXEN2 - Timer 2 external enable. EXEN2=1 enables capture or reload to occur as a result of a high-to-low transition on the T2EX pin, if Timer 2 is not generating baud rates for the serial port. EXEN2=0 causes Timer 2 to ignore all external events on the T2EX pin.
T2CON.2	TR2 - Timer 2 run control flag. TR2=1 starts Timer 2; TR2=0 stops Timer 2.
T2CON.1	C/T2 - Counter/Timer select. When $C/\overline{T}2 = 1$, Timer 2 is clocked by high-to-low transitions on the T2 pin. When $C/\overline{T}2 = 0$ in modes 0, 1, or 2, Timer 2 is clocked by CLKOUT/4 or CLKOUT/12, depending on the state of T2M (CKCON.5). When $C/\overline{T}2 = 0$ in mode 3, Timer 2 is clocked by CLKOUT/2, regardless of the state of CKCON.5.
T2CON.0	CP/RL2 - Capture/reload flag. When $CP/\overline{RL}2=1$, Timer 2 captures occur on high-to-low transitions of the T2EX pin, if EXEN2 = 1. When $CP/\overline{RL}2 = 0$, auto-reloads occur when Timer 2 overflows or when high-to-low transitions occur on the T2EX pin, if EXEN2 = 1. If either RCLK or TCLK is set to '1', CP/RL2 does not function and Timer 2 operates in auto-reload mode following each overflow.

14.2.4.1 Timer 2 Mode Control

Table 14-6 summarizes how the T2CON bits determine the Timer 2 mode.

Table 14-6. Timer 2 Mode Control Summary

TR2	TCLK	RCLK	CP/RL2	Mode
0	X	X	X	Timer 2 stopped
1	1	X	X	Baud rate generator
1	X	1	X	Baud rate generator
1	0	0	0	16 bit timer/counter with auto-reload
1	0	0	1	16 bit timer/counter with capture
X = Don't care				

14.2.5 Timer 2: The 6 Bit Timer/Counter Mode

Figure 14-4 illustrates how Timer 2 operates in timer/counter mode with the optional capture feature. The $C/\overline{T}2$ Bit determines whether the 16 bit counter counts CLKOUT cycles (divided by 4 or 12), or high-to-low transitions on the T2 pin. The TR2 Bit enables the counter. When the count increments from 0xFFFF, the TF2 flag is set and the T2OUT pin goes high for one CLKOUT cycle.

14.2.5.1 Timer 2 The 16 Bit Timer/Counter Mode with Capture

The Timer 2 capture mode (Figure 14-4) is the same as the 16 bit timer/counter mode, with the addition of the capture registers and control signals.

The $CP/\overline{RL}2$ Bit in the T2CON SFR enables the capture feature. When $CP/\overline{RL}2 = 1$, a high-to-low transition on the T2EX pin when EXEN2 = 1 causes the Timer 2 value to be loaded into the capture registers RCAP2L and RCAP2H.

Figure 14-4. Timer 2 - Timer/Counter with Capture

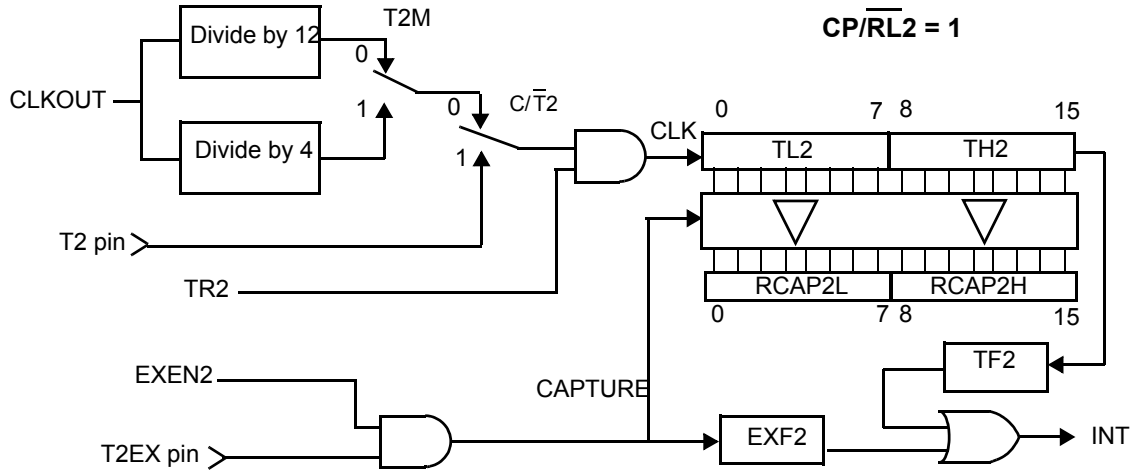

14.2.6 Timer 2: 16 Bit Timer/Counter Mode with Auto-Reload

When $CP/RL2 = 0$, Timer 2 is configured for the auto-reload mode illustrated in Figure 14-5. Control of counter input is the same as for the other 16 bit counter modes. When the count increments from 0xFFFF, Timer 2 sets the TF2 flag

and the starting value is reloaded into TL2 and TH2. Software must preload the starting value into the RCAP2L and RCAP2H registers.

When Timer 2 is in auto-reload mode, a reload can be forced by a high-to-low transition on the T2EX pin, if enabled by EXEN2 = 1.

Figure 14-5. Timer 2 - Timer/Counter with Auto Reload

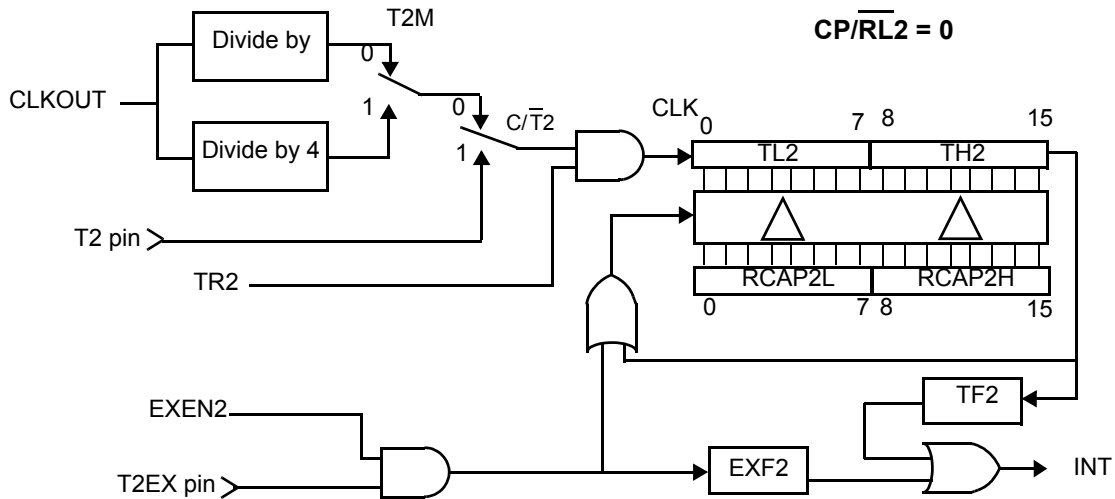

14.2.7 Timer 2: Baud Rate Generator Mode

Set either RCLK or TCLK to '1' to configure Timer 2 to generate baud rates for Serial Port 0 in serial mode 1 or 3. Figure 14-6 on page 200 is the functional diagram for the Timer 2 baud rate generator mode. In baud rate generator mode, Timer 2 functions in auto-reload mode. However, instead of setting the TF2 flag, the counter overflow is used to generate a shift clock for the serial port function. As in normal auto-reload mode, the overflow also causes the pre-loaded start value in the RCAP2L and RCAP2H Registers to be reloaded into the TL2 and TH2 Registers.

When either TCLK = 1 or RCLK = 1, Timer 2 is forced into auto-reload operation, regardless of the state of the CP/RL2

Bit. Timer 2 is used as the receive baud clock source when RCLK=1, and as the transmit baud clock source when TCLK=1.

When operating as a baud rate generator, Timer 2 does not set the TF2 Bit. In this mode, a Timer 2 interrupt can only be generated by a high-to-low transition on the T2EX pin setting the EXF2 Bit, and only if enabled by EXEN2 = 1.

The counter time base in baud rate generator mode is CLK-OUT/2. To use an external clock source, set C/T2 to '1' and apply the desired clock source to the T2 pin.

Note The maximum frequency for an external clock source on the T2 pin is 6 MHz.

Figure 14-6. Timer 2 - Baud Rate Generator Mode

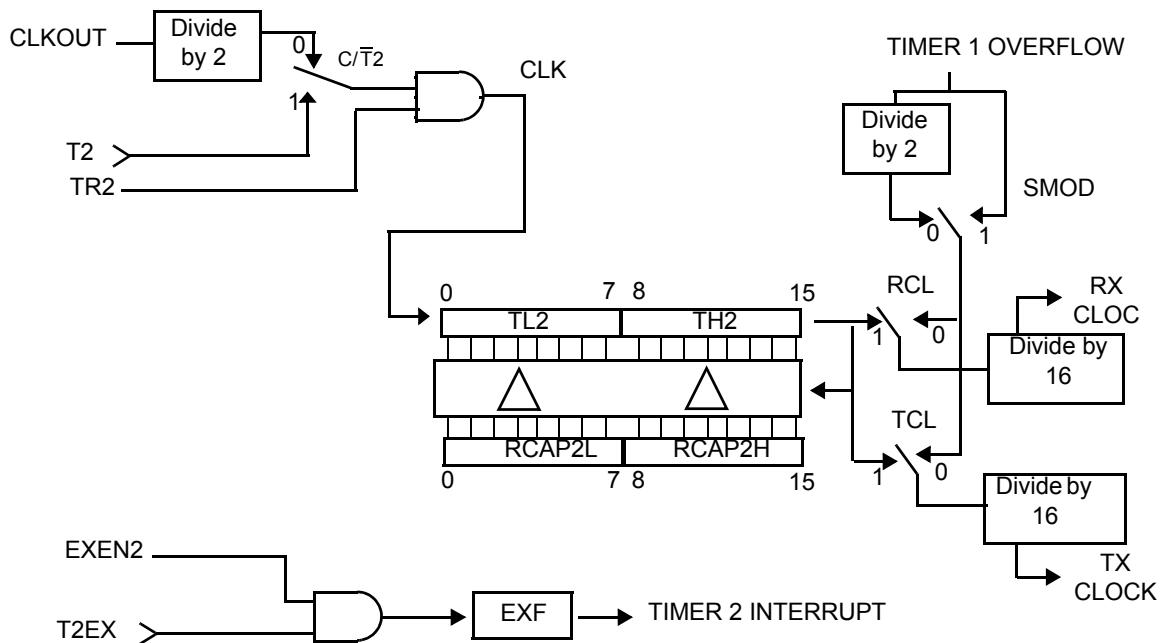

14.3 Serial Interface

The EZ-USB provides two serial ports. Serial Port 0 operates almost exactly as a standard 8051 serial port; depending on the configured mode (see [Table 14-7](#)), its baud-clock source can be CLKOUT/4 or CLKOUT/12, Timer 1, Timer 2, or the High-Speed Baud Rate Generator (see section [14.3.2 High-Speed Baud Rate Generator on page 202](#)). Serial Port 1 is identical to Serial Port 0, except that it cannot use Timer 2 as its baud rate generator. The number of serial ports available externally vary depending on the package. See package information in [Introducing EZ-USB® chapter on page 13](#).

Each serial port can operate in synchronous or asynchronous mode. In synchronous mode, the EZ-USB generates the serial clock and the serial port operates in half duplex mode. In asynchronous mode, the serial port operates in full duplex mode. In all modes, the EZ-USB double buffers the incoming data so that a byte of incoming data can be received while firmware is reading the previously received byte.

Each serial port can operate in one of four modes, as outlined in [Table 14-7](#).

The registers associated with the serial ports are as follows. (Registers PCON and EICON also include some functionality which is not part of the Serial Interface).

- PCON (SFR 0x87) Bit 7, Serial Port 0 rate control SMOD0 ([Table 14-13 on page 203](#))
- SCON0 (SFR 0x98) Serial Port 0 control ([Table 14-11 on page 203](#))
- SBUF0 (SFR 0x99) Serial Port 0 transmit/receive buffer
- EICON (SFR 0xD8) Bit 7, Serial Port 1 rate control SMOD1 ([Table 14-12 on page 203](#))
- SCON1 (SFR 0xC0) Serial Port 1 control ([Table 14-14 on page 203](#))
- SBUF1 (SFR 0xC1) Serial Port 1 transmit/receive buffer
- T2CON (SFR 0xC8) Baud clock source for modes 1 and 3 (RCLK and TCLK in [Table 14-5 on page 198](#))
- UART230 (0xE608) High-Speed Baud Rate Generator enable (see section [14.3.2 High-Speed Baud Rate Generator](#))

Table 14-7. Serial Port Modes

Mode	Sync/ Async	Baud-Clock Source	Data Bits	Start/ Stop	9th Bit Function
0	Sync	CLKOUT/4 or CLKOUT/12	8	None	None
1	Async	Timer 1 (Ports 0 and 1), Timer 2 (Port 0 only), or High-Speed Baud Rate Generator (Ports 0 and 1)	8	1 start, 1 stop	None
2	Async	CLKOUT/32 or CLKOUT/64	9	1 start, 1 stop	0, 1, or parity
3	Async	Timer 1 (Ports 0 and 1), Timer 2 (Port 0 only), or High-Speed Baud Rate Generator (Ports 0 and 1)	9	1 start, 1 stop	0, 1, or parity

Note: The High-Speed Baud Rate Generator provides 115.2K or 230.4K baud rates (see section [14.3.2 High-Speed Baud Rate Generator on page 202](#)).

14.3.1 803x/805x Compatibility

The implementation of the serial interface is similar to that of the Dallas Semiconductor, DS80C320. Table 14-8 summarizes the differences in serial interface implementation between the Intel 8051, the Dallas Semiconductor DS80C320, and the EZ-USB.

Table 14-8. Serial Interface Implementation Comparison

Feature	Intel 8051	Dallas DS80C320	EZ-USB
Number of serial ports	1	2	2
Framing error detection	not implemented	implemented	not implemented
Slave address comparison for multiprocessor communication	not implemented	implemented	not implemented

14.3.2 High-Speed Baud Rate Generator

The EZ-USB incorporates a high speed baud rate generator which can provide 115.2K and 230.4K baud rates for either or both serial ports, regardless of the EZ-USB's internal clock frequency (12, 24, or 48 MHz).

The high-speed baud rate generator is enabled for Serial Port 0 by setting UART230.0 to '1'; it is enabled for Serial Port 1 by setting UART230.1 to '1'.

When enabled, the high speed baud rate generator defaults to 115.2K baud. To select 230.4K baud for Serial Port 0, set SMOD0 (PCON.7) to '1'; for Serial Port 1, set SMOD1 (EICON.7) to '1'.

Table 14-9. UART230 Register — Address 0xE608

Bit	Function
UART230.7:2	Reserved
UART230.1	230UART1 - Enable high-speed baud rate generator for serial port 1. When 230UART1 = 1, a 115.2K baud (if SMOD1 = 0) or 230.4K baud (if SMOD1 = 1) clock is provided to serial port 1. When 230UART1 = 0, serial port 1's baud clock is provided by one of the sources shown in Table 14-7 on page 201.
UART230.0	230UART0 - Enable high-speed baud rate generator for serial port 0. When 230UART0 = 1, a 115.2K baud (if SMOD0 = 0) or 230.4K baud (if SMOD0 = 1) clock is provided to serial port 0. When 230UART1 = 0, serial port 0's baud clock is provided by one of the sources shown in Table 14-7 on page 201.

Note When the High-Speed Baud Rate Generator is enabled for either serial port, **neither** port may use Timer 1 as its baud-clock source. Therefore, the allowable combina-

tions of baud clock sources for Modes 1 and 3 are listed below.

Table 14-10. Allowable Baud-Clock Combinations for Modes 1 and 3

Port 0	Port 1
Timer 1	Timer 1
Timer 2	Timer 1
Timer 2	High Speed Baud Rate Generator
High Speed Baud Rate Generator	High Speed Baud Rate Generator

14.3.3 Mode 0

Serial mode 0 provides synchronous, half duplex serial communication. For Serial Port 0, serial data output occurs on the RXD0OUT pin, serial data is received on the RXD0 pin, and the TXD0 pin provides the shift clock for both transmit and receive. For Serial Port 1, the corresponding pins are RXD1OUT, RXD1, and TXD1.

The serial mode 0 baud rate is either CLKOUT/12 or CLKOUT/4, depending on the state of the SM2_0 bit (or SM2_1 for Serial Port 1). When SM2_0 = 0, the baud rate is CLKOUT/12, when SM2_0 = 1, the baud rate is CLKOUT/4.

Mode 0 operation is identical to the standard 8051. Data transmission begins when an instruction writes to the SBUF0 (or SBUF1) SFR. The USART shifts the data, LSB first, at the selected baud rate, until the 8 bit value has been shifted out.

Mode 0 data reception begins when the REN_0 (or REN_1) bit is set and the RI_0 (or RI_1) bit is cleared in the corresponding SCON SFR. The shift clock is activated and the USART shifts data, LSB first, in on each rising edge of the shift clock until eight bits have been received. One CLKOUT cycle after the eighth bit is shifted in, the RI_0 (or RI_1) bit is set and reception stops until the software clears the RI bit.

Figure 14-7 on page 204 through Figure 14-10 on page 205 illustrate Serial Port Mode 0 transmit and receive timing for both low speed (CLKOUT/12) and high speed (CLKOUT/4) operation. The figures show Port 0 signal names, RXD0, RXD0OUT, and TXD0. The timing is the same for Port 1 signals RXD1, RXD1OUT, and TXD1, respectively.

Table 14-11. SCON0 Register — SFR 98h

Bit	Function															
SCON0.7	SM0_0 - Serial Port 0 mode bit 0.															
SCON0.6	SM1_0 - Serial Port 0 mode bit 1, decoded as: <table border="1" style="margin-left: 20px;"> <thead> <tr> <th>SM0_0</th> <th>SM1_0</th> <th>Mode</th> </tr> </thead> <tbody> <tr> <td>0</td> <td>0</td> <td>0</td> </tr> <tr> <td>0</td> <td>1</td> <td>1</td> </tr> <tr> <td>1</td> <td>0</td> <td>2</td> </tr> <tr> <td>1</td> <td>1</td> <td>3</td> </tr> </tbody> </table>	SM0_0	SM1_0	Mode	0	0	0	0	1	1	1	0	2	1	1	3
SM0_0	SM1_0	Mode														
0	0	0														
0	1	1														
1	0	2														
1	1	3														
SCON0.5	SM2_0 - Multiprocessor communication enable. In modes 2 and 3, this bit enables the multiprocessor communication feature. If SM2_0 = 1 in mode 2 or 3, then RI_0 is not activated if the received ninth bit is zero. If SM2_0=1 in mode 1, then only RI_0 is activated if a valid stop is received. In mode 0, SM2_0 establishes the baud rate: when SM2_0=0, the baud rate is CLKOUT/12; when SM2_0=1, the baud rate is CLKOUT/4.															
SCON0.4	REN_0 - Receive enable. When REN_0=1, reception is enabled.															
SCON0.3	TB8_0 - Defines the state of the 9th data bit transmitted in modes 2 and 3.															
SCON0.2	RB8_0 - In modes 2 and 3, RB8_0 indicates the state of the 9th bit received. In mode 1, RB8_0 indicates the state of the received stop bit. In mode 0, RB8_0 is not used.															
SCON0.1	TI_0 - Transmit interrupt flag. Indicates that the transmit data word has been shifted out. In mode 0, TI_0 is set at the end of the 8th data bit. In all other modes, TI_0 is set when the stop bit is placed on the TXD0 pin. TI_0 must be cleared by firmware.															
SCON0.0	RI_0 - Receive interrupt flag. Indicates that serial data word has been received. In mode 0, RI_0 is set at the end of the 8th data bit. In mode 1, RI_0 is set after the last sample of the incoming stop bit, subject to the state of SM2_0. In modes 2 and 3, RI_0 is set at the end of the last sample of RB8_0. RI_0 must be cleared by firmware.															

Table 14-12. EICON (SFR 0xD8) SMOD1 Bit

Bit	Function
EICON.7	SMOD1 - Serial Port 1 baud rate doubler enable. When SMOD1 = 1 the baud rate for Serial Port is doubled.

Table 14-13. PCON (SFR 0x87) SMOD0 Bit

Bit	Function
PCON.7	SMOD0 - Serial Port 0 baud rate double enable. When SMOD0 = 1, the baud rate for Serial Port 0 is doubled.

Table 14-14. SCON1 Register—SFR C0h

Bit	Function															
SCON1.7	SM0_1 - Serial Port 1 mode bit 0.															
SCON1.6	SM1_1 - Serial Port 1 mode bit 1, decoded as: <table border="1" style="margin-left: 20px;"> <thead> <tr> <th>SM0_1</th> <th>SM1_1</th> <th>Mode</th> </tr> </thead> <tbody> <tr> <td>0</td> <td>0</td> <td>0</td> </tr> <tr> <td>0</td> <td>1</td> <td>1</td> </tr> <tr> <td>1</td> <td>0</td> <td>2</td> </tr> <tr> <td>1</td> <td>1</td> <td>3</td> </tr> </tbody> </table>	SM0_1	SM1_1	Mode	0	0	0	0	1	1	1	0	2	1	1	3
SM0_1	SM1_1	Mode														
0	0	0														
0	1	1														
1	0	2														
1	1	3														
SCON1.5	SM2_1 - Multiprocessor communication enable. In modes 2 and 3, this bit enables the multiprocessor communication feature. If SM2_1 = 1 in mode 2 or 3, then RI_1 is not activated if the received ninth bit is '0'. If SM2_1=1 in mode 1, then only RI_1 is activated if a valid stop is received. In mode 0, SM2_1 establishes the baud rate: when SM2_1=0, the baud rate is CLKOUT/12; when SM2_1=1, the baud rate is CLKOUT/4.															
SCON1.4	REN_1 - Receive enable. When REN_1=1, reception is enabled.															

Table 14-14. SCON1 Register—SFR C0h

Bit	Function
SCON1.3	TB8_1 - Defines the state of the ninth data bit transmitted in modes 2 and 3.
SCON1.2	RB8_1 - In modes 2 and 3, RB8_1 indicates the state of the ninth bit received. In mode 1, RB8_1 indicates the state of the received stop bit. In mode 0, RB8_1 is not used.
SCON1.1	TI_1 - Transmit interrupt flag. Indicates that the transmit data word has been shifted out. In mode 0, TI_1 is set at the end of the eighth data bit. In all other modes, TI_1 is set when the stop bit is placed on the TXD1 pin. TI_1 must be cleared by the software.
SCON1.0	RI_1 - Receive interrupt flag. Indicates that serial data word has been received. In mode 0, RI_1 is set at the end of the eighth data bit. In mode 1, RI_1 is set after the last sample of the incoming stop bit, subject to the state of SM2_1. In modes 2 and 3, RI_1 is set at the end of the last sample of RB8_1. RI_1 must be cleared by the software.

Figure 14-7. Serial Port Mode 0 Receive Timing - Low Speed Operation

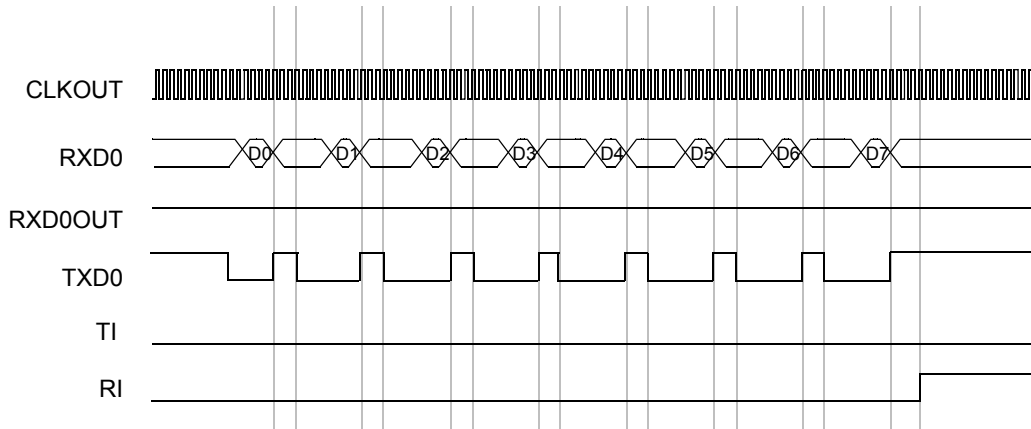
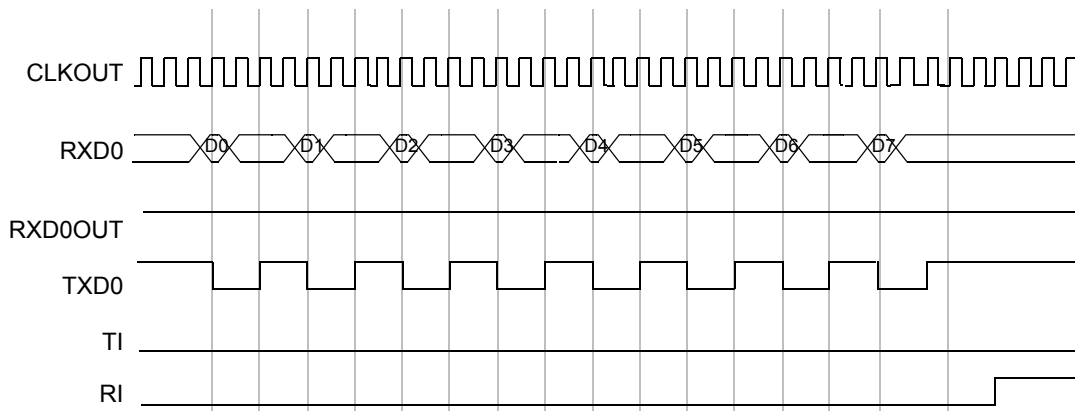

Figure 14-8. Serial Port Mode 0 Receive Timing - High Speed Operation



Note At both low and high speed in Mode 0, data on RXD0 is sampled two CLKOUT cycles before the rising clock edge on TXD0.

Figure 14-9. Serial Port Mode 0 Transmit Timing - Low Speed Operation

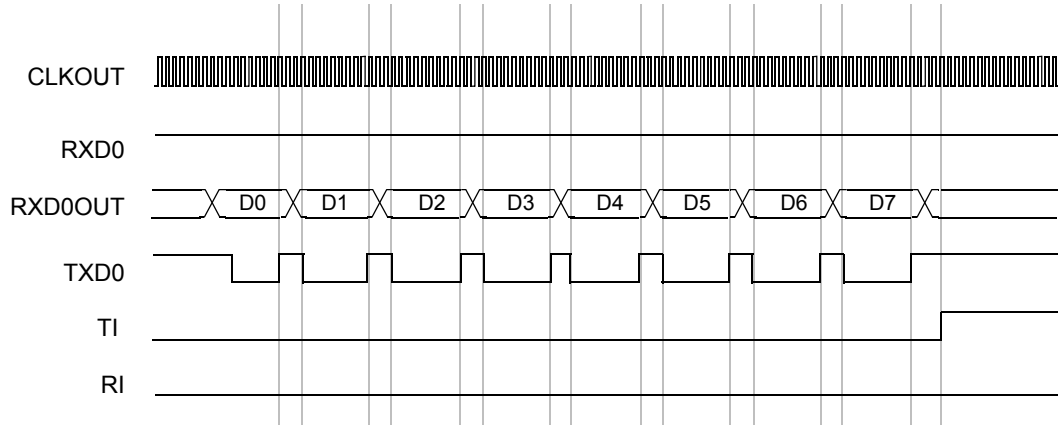
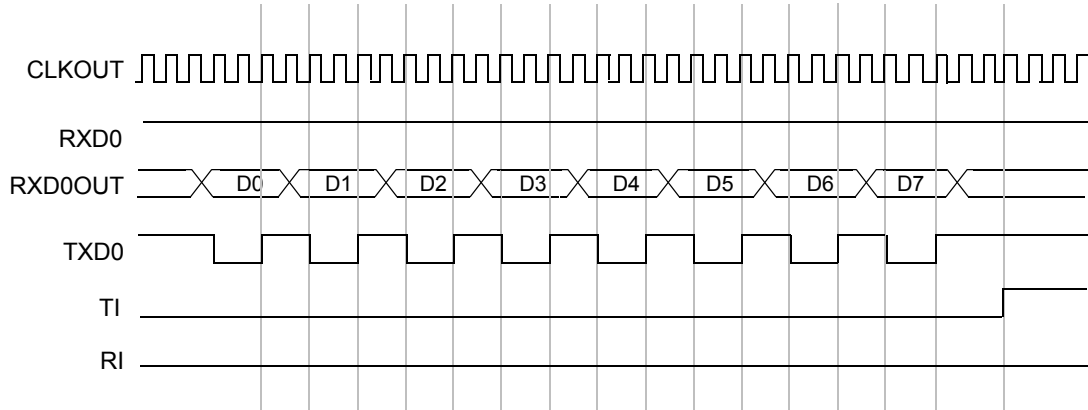

Figure 14-10. Serial Port Mode 0 Transmit Timing - High Speed Operation



14.3.4 Mode 1

Mode 1 provides standard asynchronous, full-duplex communication, using a total of 10 bits: one start bit, eight data bits, and one stop bit. For receive operations, the stop bit is stored in RB8_0 (or RB8_1). Data bits are received and transmitted LSB first.

Mode 1 operation is identical to that of the standard 8051 when Timer 1 uses CLKOUT/12, (T1M=0, the default).

14.3.4.1 Mode 1 Baud Rate

The mode 1 baud rate is a function of timer overflow. Serial Port 0 can use either Timer 1 or Timer 2 to generate baud rates. Serial Port 1 can only use Timer 1. The two serial ports can run at the same baud rate if they both use Timer 1, or different baud rates if Serial Port 0 uses Timer 2 and Serial Port 1 uses Timer 1.

Each time the timer increments from its maximum count (0xFF for Timer 1 or 0xFFFF for Timer 2), a clock is sent to the baud rate circuit. That clock is then divided by 16 to generate the baud rate.

When using Timer 1, the SMOD0 (or SMOD1) Bit selects whether or not to divide the Timer 1 rollover rate by 2. Therefore, when using Timer 1, the baud rate is determined by the equation:

$$\text{Baud Rate} = \frac{2^{SMODx}}{32} \times \text{Timer 1 Overflow} \quad \text{Equation 1}$$

When using Timer 2, the baud rate is determined by the equation:

$$\text{Baud Rate} = \frac{\text{Timer 2 Overflow}}{16} \quad \text{Equation 2}$$

To use Timer 1 as the baud rate generator, it is generally best to use Timer 1 mode 2 (eight bit counter with auto-reload), although any counter mode can be used. In mode 2, the Timer 1 reload value is stored in the TH1 register, which makes the complete formula for Timer 1:

Equation 3

$$Baud\ Rate = \frac{2^{SMODx}}{32} \times \frac{CLKOUT}{(12 - 8 \times T1M) \times (256 - TH1)}$$

To derive the required TH1 value from a known baud rate when T1M=0, use the equation:

$$TH1 = 256 - \frac{2^{SMODx} \times CLKOUT}{384 \times Baud\ Rate}$$

Equation 4

To derive the required TH1 value from a known baud rate when T1M=1, use the equation:

$$TH1 = 256 - \frac{2^{SMODx} \times CLKOUT}{128 \times Baud\ Rate}$$

Equation 5

Note Very low serial port baud rates may be achieved with Timer 1 by enabling the Timer 1 interrupt, configuring Timer 1 to mode 1, and using the Timer 1 interrupt to initiate a 16 bit software reload.

Table 14-15 lists sample reload values for a variety of common serial port baud rates, using Timer 1 operating in mode

2 (TMOD.5:4=10) with a CLKOUT/4 clock source (T1M=1) and the full timer rollover (SMOD1=1)

More accurate baud rates may be achieved by using Timer 2 as the baud rate generator. To use Timer 2 as the baud rate generator, configure Timer 2 in auto-reload mode and set the TCLK and/or RCLK bits in the T2CON SFR. TCLK selects Timer 2 as the baud rate generator for the transmitter; RCLK selects Timer 2 as the baud rate generator for the receiver. The 16 bit reload value for Timer 2 is stored in the RCAP2L and RCA2H SFRs, which makes the equation for the Timer 2 baud rate:

Equation 6

$$Baud\ Rate = \frac{CLKOUT}{32 \times (65536 - (256 \times RCAP2H + RCAP2L))}$$

To derive the required RCAP2H and RCAP2L values from a known baud rate, use the equation:

$$RCAP2HL = 65536 \times \frac{CLKOUT}{32 \times Baud\ Rate}$$

Equation 7

When either RCLK or TCLK is set, the TF2 flag is not set on a Timer 2 rollover and the T2EX reload trigger is disabled.

Table 14-16 lists sample RCAP2H:L reload values for a variety of common serial baud rates.

Table 14-15. Timer 1 Reload Values for Common Serial Port Mode 1 Baud Rates

Nominal Rate	CLKOUT = 12 MHz			CLKOUT = 24 MHz			CLKOUT = 48 MHz		
	TH1 Reload Value	Actual Rate	Error	TH1 Reload Value	Actual Rate	Error	TH1 Reload Value	Actual Rate	Error
57600	FD	62500	+8.50%	F9	53571	-6.99%	F3	57692	+0.16%
38400	FB	37500	-2.34%	F6	37500	-2.34%	EC	37500	-2.34%
28800	F9	26786	-6.99%	F3	28846	+0.16%	E6	28846	+0.16%
19200	F6	18750	-2.34%	EC	18750	-2.34%	D9	19230	+0.16%
9600	EC	9375	-2.34%	D9	9615	+0.16%	B2	9615	+0.16%
4800	D9	4807	+0.16%	B2	4807	+0.16%	64	4807	+0.16%
2400	B2	2403	+0.16%	64	2403	+0.16%	—	—	—

Settings: SMOD=1, C/T=0, Timer1 Mode=2, T1M=1

Note Using rates that are off by 2% or more do not work in all systems.

Table 14-16. Timer 2 Reload Values for Common Serial Port Mode 1 Baud Rates

Nominal Rate	CLKOUT = 12 MHz			CLKOUT = 24 MHz			CLKOUT = 48 MHz		
	RCAP2H:L Reload Value	Actual Rate	Error	RCAP2H:L Reload Value	Actual Rate	Error	RCAP2H:L Reload Value	Actual Rate	Error
57600	FFF9	53571	-6.99%	FFF3	57692	+0.16%	FFE6	57692	+0.16%
38400	FFF6	37500	-2.34%	FFEC	37500	-2.34%	FFD9	38461	+0.16%
28800	FFF3	28846	+0.16%	FFE6	28846	+0.16%	FFCC	28846	+0.16%
19200	FFEC	18750	-2.34%	FFD9	19230	+0.16%	FFB2	19230	+0.16%
9600	FFD9	9615	+0.16%	FFB2	9615	+0.16%	FF64	9615	+0.16%
4800	FFB2	4807	+0.16%	FF64	4807	+0.16%	FEC8	4807	+0.16%
2400	FF64	2403	+0.16%	FEC8	2403	+0.16%	FD90	2403	+0.16%

Note using rates that are off by 2.3% or more do not work in all systems.

14.3.4.2 Mode 1 Transmit

Figure 14-11 on page 208 illustrates the mode 1 transmit timing. In mode 1, the USART begins transmitting after the first rollover of the divide-by-16 counter after the software writes to the SBUF0 (or SBUF1) register. The USART transmits data on the TXD0 (or TXD1) pin in the following order: start bit, 8 data bits (LSB first), stop bit. The TI_0 (or TI_1) bit is set 2 CLKOUT cycles after the stop bit is transmitted.

14.3.5 Mode 1 Receive

Figure 14-12 on page 208 illustrates the mode 1 receive timing. Reception begins at the falling edge of a start bit received on the RXD0 (or RXD1) pin, when enabled by the REN_0 (or REN_1) Bit. For this purpose, the RXD0 (or RXD1) pin is sampled 16 times per bit for any baud rate. When a falling edge of a start bit is detected, the divide-by-16 counter used to generate the receive clock is reset to align the counter rollover to the bit boundaries.

For noise rejection, the serial port establishes the content of each received bit by a majority decision of 3 consecutive

samples in the middle of each bit time. For the start bit, if the falling edge on the RXD0 (or RXD1) pin is not verified by a majority decision of 3 consecutive samples (low), then the serial port stops reception and waits for another falling edge on the RXD0 (or RXD1) pin.

At the middle of the stop bit time, the serial port checks for the following conditions:

- RI_0 (or RI_1) = 0
- If SM2_0 (or SM2_1) = 1, the state of the stop bit is 1 (If SM2_0 (or SM2_1) = 0, the state of the stop bit does not matter.

If the above conditions are met, the serial port then writes the received byte to the SBUF0 (or SBUF1) Register, loads the stop bit into RB8_0 (or RB8_1), and sets the RI_0 (or RI_1) Bit. If the above conditions are not met, the received data is lost, the SBUF Register and RB8 Bit are not loaded, and the RI Bit is not set.

After the middle of the stop bit time, the serial port waits for another high-to-low transition on the (RXD0 or RXD1) pin.

Figure 14-11. Serial Port 0 Mode 1 Transmit Timing

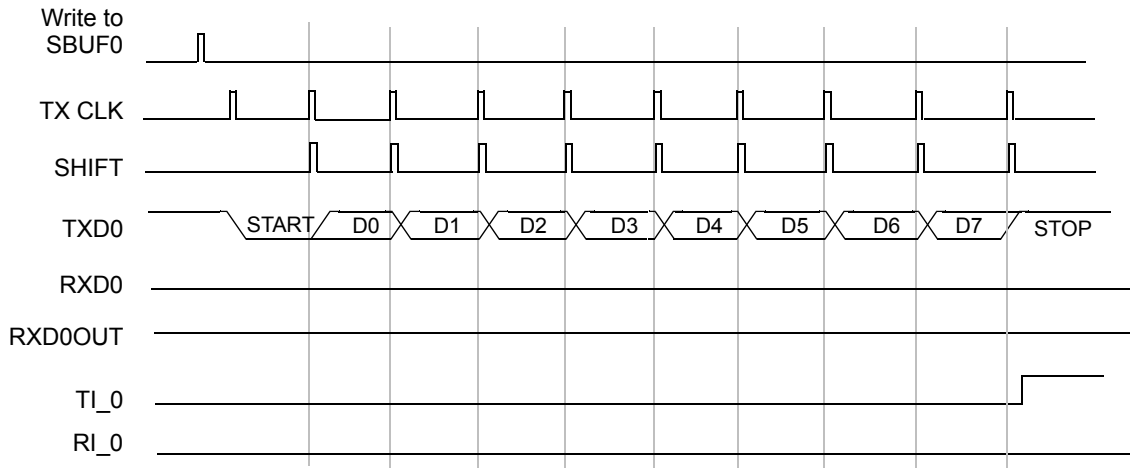
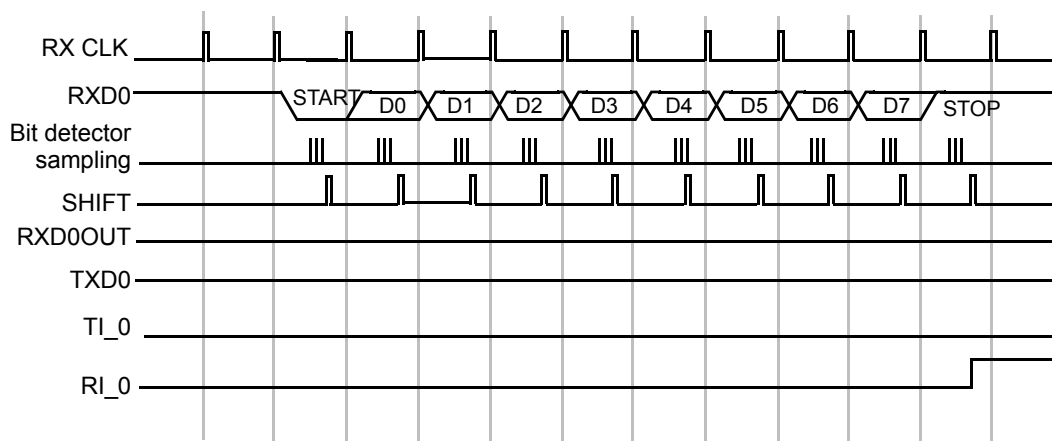

Figure 14-12. Serial Port 0 Mode 1 Receive Timing



14.3.6 Mode 2

Mode 2 provides asynchronous, full-duplex communication, using a total of 11 bits: one start bit, eight data bits, a programmable ninth bit, and one stop bit. The data bits are transmitted and received LSB first. For transmission, the ninth bit is determined by the value in TB8_0 (or TB8_1). To use the ninth bit as a parity bit, move the value of the P bit (SFR PSW.0) to TB8_0 (or TB8_1).

The Mode 2 baud rate is either CLKOUT/32 or CLKOUT/64, as determined by the SMOD0 (or SMOD1) bit. The formula for the mode 2 baud rate is:

$$Baud\ Rate = \frac{2^{SMODx} \times CLKOUT}{64} \quad \text{Equation 8}$$

Mode 2 operation is identical to the standard 8051.

14.3.6.1 Mode 2 Transmit

Figure 14-13 on page 209 illustrates the mode 2 transmit timing. Transmission begins after the first rollover of the divide-by-16 counter following a software write to SBUF0 (or SBUF1). The USART shifts data out on the TXD0 (or TXD1) pin in the following order: start bit, data bits (LSB first), ninth bit, stop bit. The TI_0 (or TI_1) Bit is set when the stop bit is placed on the TXD0 (or TXD1) pin.

14.3.6.2 Mode 2 Receive

Figure 14-14 on page 209 illustrates the mode 2 receive timing. Reception begins at the falling edge of a start bit received on the RXD0 (or RXD1) pin, when enabled by the REN_0 (or REN_1) Bit. For this purpose, the RXD0 (or RXD1) pin is sampled 16 times per bit for any baud rate. When a falling edge of a start bit is detected, the divide-by-

16 counter used to generate the receive clock is reset to align the counter rollover to the bit boundaries.

For noise rejection, the serial port establishes the content of each received bit by a majority decision of three consecutive samples in the middle of each bit time. For the start bit, if the falling edge on the RXD0 (or RXD1) pin is not verified by a majority decision of three consecutive samples (low), then the serial port stops reception and waits for another falling edge on the RXD0 (or RXD1) pin.

At the middle of the stop bit time, the serial port checks for the following conditions:

- RI_0 (or RI_1) = 0
- If SM2_0 (or SM2_1) = 1, the state of the stop bit is '1'. (If SM2_0 (or SM2_1) = 0, the state of the stop bit does not matter.)

If the above conditions are met, the serial port then writes the received byte to the SBUF0 (or SBUF1) Register, loads the stop bit into RB8_0 (or RB8_1), and sets the RI_0 (or RI_1) Bit. If the above conditions are not met, the received data is lost, the SBUF Register and RB8 Bit are not loaded, and the RI Bit is not set. After the middle of the stop bit time, the serial port waits for another high-to-low transition on the RXD0 (or RXD1) pin.

Figure 14-13. Serial Port 0 Mode 2 Transmit Timing

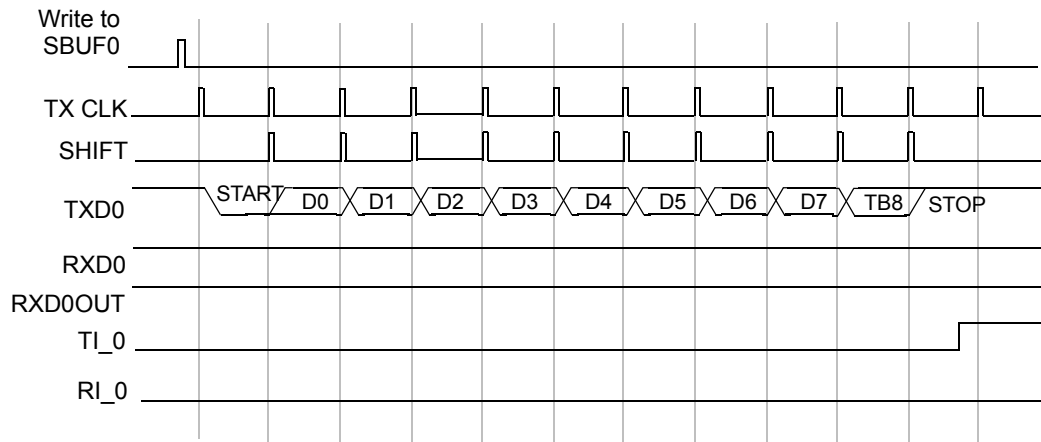
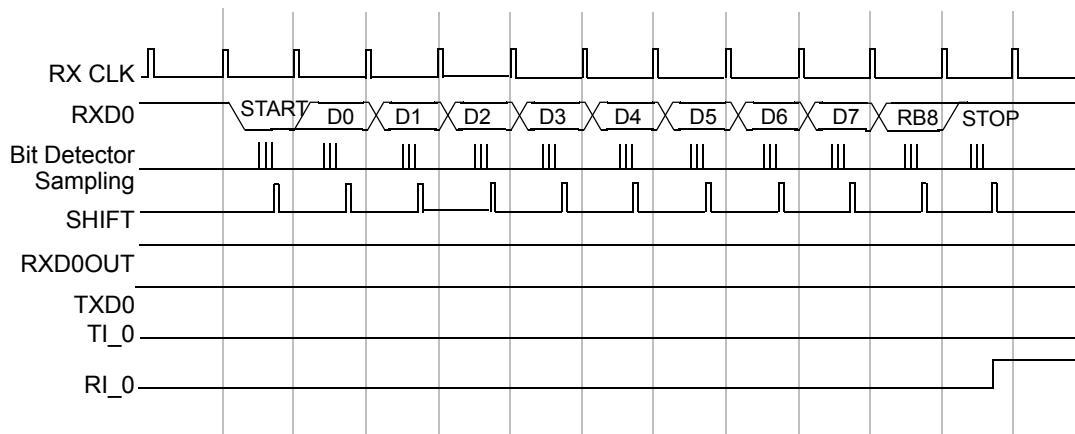

Figure 14-14. Serial Port 0 Mode 2 Receive Timing



14.3.7 Mode 3

Mode 3 provides asynchronous, full-duplex communication, using a total of 11 bits: one start bit, eight data bits, a programmable ninth bit, and one stop bit. The data bits are transmitted and received LSB first.

The mode 3 transmit and operations are identical to mode 2. The mode 3 baud rate generation is identical to mode 1.

That is, mode 3 is a combination of mode 2 protocol and mode 1 baud rate. Figure 14-15 illustrates the mode 3 transmit timing. Figure 14-16 illustrates the mode 3 receive timing.

Mode 3 operation is identical to that of the standard 8051 when Timer 1 uses CLKOUT/12, (T1M=0, the default).

Figure 14-15. Serial Port 0 Mode 3 Transmit Timing

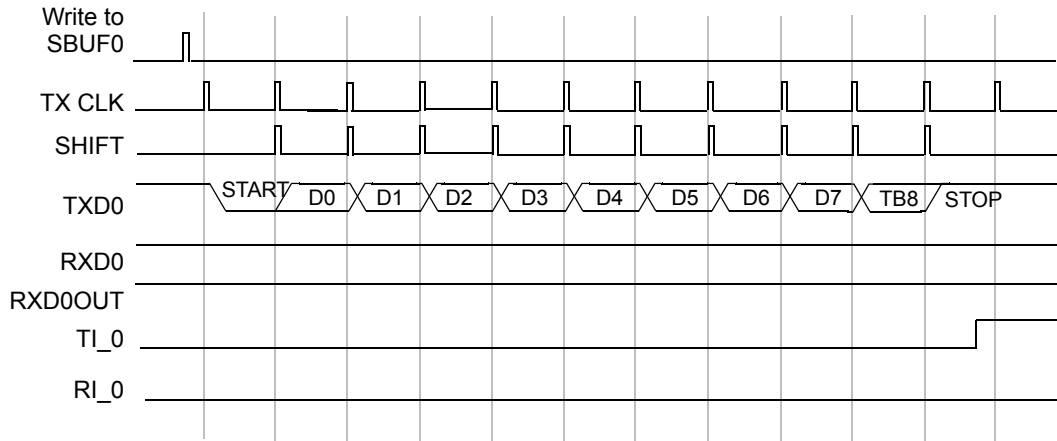
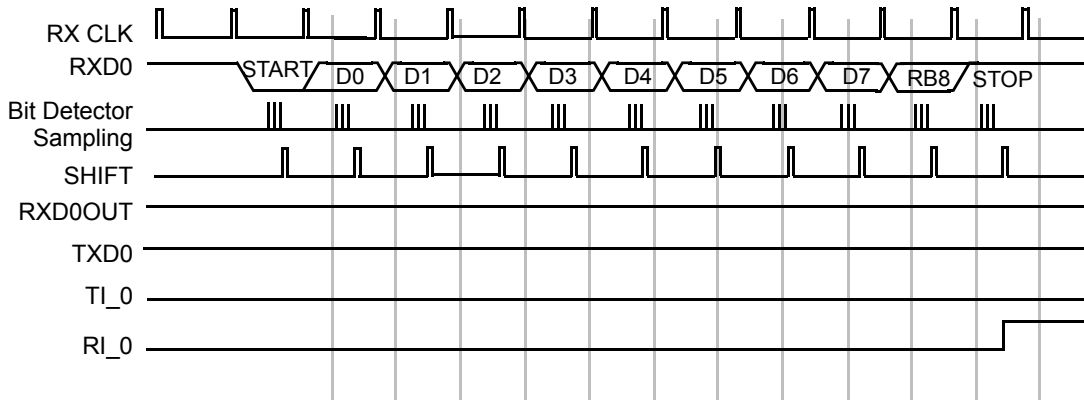

Figure 14-16. Serial Port 0 Mode 3 Receive Timing



15. Registers



15.1 Introduction

This section describes the EZ-USB registers in the order they appear in the EZ-USB memory map, see [Figure 5-4 on page 76](#). The registers are named according to the following conventions.

Most registers deal with endpoints. The general register format is **DDnFFF**, where:

DDD is endpoint direction where:

- IN or OUT with respect to the USB host.

n is the endpoint number where:

- 'ISO' indicates isochronous endpoints as a group.

FFF is the function where:

- CS is a control and status register.
- IRQ is an interrupt request bit.
- IE is an interrupt enable bit.
- BC, BCL, and BCH are byte count registers. BC is used for single byte counts, and BCH/BCL are used as the high and low bytes of 16-bit byte counts.
- DATA is a single-register access to a FIFO.
- BUF is the start address of a buffer.

15.1.1 Example Register Format

- EP1INBC is the Endpoint 1 IN byte count.

15.1.2 Other Conventions

USB indicates a global (not endpoint specific) USB function.

ADDR is an address.

VAL means valid.

FRAME is a frame count.

PTR is an address pointer.

Register Name							Register Function	Address
b7	b6	b5	b4	b3	b2	b1	b0	
bitname	bitname	bitname	bitname	bitname	bitname	bitname	bitname	
R, W access	R, W access	R, W access	R, W access	R, W access	R, W access	R, W access	R, W access	
Default val	Default val	Default val	Default val	Default val	Default val	Default val	Default val	

The register table above illustrates the register description format used in this chapter.

- The top line shows the register name, functional description, and address in the EZ-USB memory.
- The second line shows the bit position in the register.
- The third line shows the name of each bit in the register.
- The fourth line shows CPU accessibility: Read, Write, or R/W.
- The fifth line shows the default value. These values apply after a hard reset.

15.2 Special Function Registers

EZ-USB implements many control registers as SFRs (Special Function Registers). These SFRs are shown in [Table 15-1](#). Bold type indicates SFRs that are not in the standard 8051, but are included in the EZ-USB.

Table 15-1. EZ-USB Special Function Registers (SFR)

x	8x	9x	Ax	Bx	Cx	Dx	Ex	Fx
0	IOA	IOB	IOC	IOD	SCON1	PSW	ACC	B
1	SP	EXIF	INT2CLR	IOE	SBUF1			
2	DPL0	MPAGE	INT4CLR	OEA				
3	DPH0			OEB				
4	DPL1			OEC				
5	DPH1			OED				
6	DPS			OEE				
7	PCON							
8	TCON	SCON0	IE	IP	T2CON	EICON	EIE	EIP
9	TMOD	SBUF0						
A	TL0	AUTOPTRH1	EP2468STAT	EP01STAT	RCAP2L			
B	TL1	AUTOPTL1	EP24FIFOFLGS	GPIFTRIG	RCAP2H			
C	TH0		EP68FIFOFLGS		TL2			
D	TH1	AUTOPTRH2		GPIFGLDATH	TH2			
E	CKCON	AUTOPTL2		GPIFGLDATLX				
F			AUTOPTR-SETUP	GPIFGLDATLNOX				

All unlabeled SFRs are reserved.

15.3 About SFRs

Because the SFRs are directly addressable internal registers, firmware can access them quickly, without the overhead of loading the data pointer and performing a MOVX instruction. For example, the firmware reads the EZ-USB Port B pins using a single instruction, as shown below.

Single instruction to read port B:

```
mov    a, IOB
```

In the same manner, firmware writes the value 0x55 to Port C using only one MOV instruction, as shown below.

Single instruction to read port C:

```
mov    IOC, #55h
```

SFRs in rows 0 and 8 are bit-addressable; individual bits of the registers may be efficiently set, cleared, or toggled using special bit-addressing instructions (for example, **setb IOB.2** sets bit 2 of the IOB register).

IOA		Port A (bit addressable)						SFR 0x80
b7	b6	b5	b4	b3	b2	b1	b0	
D7	D6	D5	D4	D3	D2	D1	D0	
R/W	R/W	R/W	R/W	R/W	R/W	R/W	R/W	
x	x	x	x	x	x	x	x	

IOB		Port B (bit addressable)						SFR 0x90
b7	b6	b5	b4	b3	b2	b1	b0	
D7	D6	D5	D4	D3	D2	D1	D0	
R/W	R/W	R/W	R/W	R/W	R/W	R/W	R/W	
x	x	x	x	x	x	x	x	

AUTOPTRH1		Autopointer 1 Address HIGH						SFR 0x9A
b7	b6	b5	b4	b3	b2	b1	b0	
A15	A14	A13	A12	A11	A10	A9	A8	
R/W	R/W	R/W	R/W	R/W	R/W	R/W	R/W	
0	0	0	0	0	0	0	0	

AUTOPTL1		Autopointer 1 Address Low						SFR 0x9B
b7	b6	b5	b4	b3	b2	b1	b0	
A7	A6	A5	A4	A3	A2	A1	A0	
R/W	R/W	R/W	R/W	R/W	R/W	R/W	R/W	
0	0	0	0	0	0	0	0	

AUTOPTRH2							Autopointer 2 Address HIGH	SFR 0x9D
b7	b6	b5	b4	b3	b2	b1	b0	
A15	A14	A13	A12	A11	A10	A9	A8	
R/W	R/W	R/W	R/W	R/W	R/W	R/W	R/W	
0	0	0	0	0	0	0	0	

AUTOPTL2							Autopointer 2 Address Low	SFR 0x9E
b7	b6	b5	b4	b3	b2	b1	b0	
A7	A6	A5	A4	A3	A2	A1	A0	
R/W	R/W	R/W	R/W	R/W	R/W	R/W	R/W	
0	0	0	0	0	0	0	0	

IOC							Port C (bit addressable)	SFR 0xA0
b7	b6	b5	b4	b3	b2	b1	b0	
D7	D6	D5	D4	D3	D2	D1	D0	
R/W	R/W	R/W	R/W	R/W	R/W	R/W	R/W	
x	x	x	x	x	x	x	x	

INT2CLR							Interrupt 2 Clear	SFR 0xA1
b7	b6	b5	b4	b3	b2	b1	b0	
x	x	x	x	x	x	x	x	
W	W	W	W	W	W	W	W	
x	x	x	x	x	x	x	x	

INT4CLR							Interrupt 4 Clear	SFR 0xA2
b7	b6	b5	b4	b3	b2	b1	b0	
x	x	x	x	x	x	x	x	
W	W	W	W	W	W	W	W	
x	x	x	x	x	x	x	x	

Writing any value to INT2CLR or INT4CLR clears the INT2 or INT4 interrupt request bit for the INT2/INT4 interrupt currently being serviced.

Note Writing to one of these registers has the same effect as clearing the appropriate interrupt request bit in the EZ-USB external register space. For example, suppose the EP2 Empty Flag interrupt is asserted. The EZ-USB automatically sets bit 1 of the EP2FIFOIRQ register (in External Data memory space, at 0xE651), and asserts the INT4 interrupt request.

Using autovectoring, the EZ-USB automatically calls (vectors to) the EP2_FIFO_EMPTY 2 Interrupt Service Routine (ISR). The first task in the ISR is to clear the interrupt request bit, EP2FIFOIRQ.1. The firmware can do this either by accessing the EP2FIFOIRQ register (at 0xE651) and writing a '1' to bit 1, or simply by writing any value to INT4CLR. The first method requires the use of the data pointer, which must be saved and restored along with the accumulator in an ISR. The second method is much faster and does not require saving the data pointer, so it is preferred.

EP2468STAT							Endpoints 2,4,6,8 Status Flags	SFR 0xAA
b7	b6	b5	b4	b3	b2	b1	b0	
EP8F	EP8E	EP6F	EP6E	EP4F	EP4E	EP2F	EP2E	
R	R	R	R	R	R	R	R	
0	1	0	1	1	0	1	0	

The bits in EP2468STAT correspond to Endpoint Status bits in the EZ-USB register file, as follows:

Table 15-2. SFR and EZ-USB Register File Correspondences

Bit	EPSTAT SFR	EZ-USB Register.Bit	EZ-USB Register File address
7	EP8 Full flag	EP8CS.3	E6A6
6	EP8 Empty flag	EP8CS.2	E6A6
5	EP6 Full flag	EP6CS.3	E6A5
4	EP6 Empty flag	EP6CS.2	E6A5
3	EP4 Full flag	EP4CS.3	E6A4
2	EP4 Empty flag	EP4CS.2	E6A4
1	EP2 Full flag	EP2CS.3	E6A3
0	EP2 Empty flag	EP2CS.2	E6A3

Note The Endpoint status bits represent the Packet Status.

EP24FIFOFLGS							Endpoints 2, 4 Slave FIFO Status Flags	SFR 0xAB
b7	b6	b5	b4	b3	b2	b1	b0	
0	EP4PF	EP4EF	EP4FF	0	EP2PF	EP2EF	EP2FF	
R	R	R	R	R	R	R	R	
0	0	1	0	0	0	1	0	

EP68FIFOFLGS							Endpoints 6, 8 Slave FIFO Status Flags	SFR 0xAC
b7	b6	b5	b4	b3	b2	b1	b0	
0	EP8PF	EP8EF	EP8FF	0	EP6PF	EP6EF	EP6FF	
R	R	R	R	R	R	R	R	
0	1	1	0	0	1	1	0	

AUTOPTRSETUP							Autopointers 1 and 2 Setup	SFR 0xAF
b7	b6	b5	b4	b3	b2	b1	b0	
0	0	0	0	0	APTR2INC	APTR1INC	APTREN	
R/W	R/W	R/W	R/W	R/W	R/W	R/W	R/W	
0	0	0	0	0	1	1	0	

EZ-USB provides two identical autopointers. They are similar to the internal ‘DPTR’ data pointers, but with an additional feature: each can automatically increment after every memory access. Using one or both of the autopointers, EZ-USB firmware can perform very fast block memory transfers.

The AUTOPTRSETUP register is configured as follows:

- Set APTRnINC=0 to freeze the address pointer, APTRnINC=1 to automatically increment it for every read or write of an XAUTODATn register. This bit defaults to ‘1’, enabling the auto increment feature.
- To enable the autopointer, set APTREN=1. Enabling the Autopointers has one side-effect: any code access (an instruction fetch, for instance) from addresses 0xE67B and 0xE67C return the AUTODATA values, rather than the code-memory values at these two addresses. This introduces a two-byte ‘hole’ in the code memory.

The firmware then writes a 16 bit address to AUTOPTRHn/Ln. Then, for every read or write of an XAUTODATn register, the address pointer automatically increments (if APTRnINC=1).

SFR

Port D (bit addressable)							SFR 0xB0
b7	b6	b5	b4	b3	b2	b1	b0
D7	D6	D5	D4	D3	D2	D1	D0
R/W	R/W	R/W	R/W	R/W	R/W	R/W	R/W
x	x	x	x	x	x	x	x

EZ-USB I/O ports PORTA-PORTD appear as bit addressable SFRs. Reading a register or bit returns the logic level of the port pin that is two CLKOUT clocks old. Writing a register bit writes the port latch. Whether or not the port latch value appears on the I/O pin depends on the state of the pin's OE (Output Enable) bit. The I/O pins may also be assigned alternate function values, in which case the IOx and OEx bit values are overridden on a bit-by-bit basis.

IOD is bit-addressable. Use Bit 2 to set PORTD - single instruction:

```
setb IOD.2 ; set bit 2 of IOD SFR
```

Port E							SFR 0xB1
b7	b6	b5	b4	b3	b2	b1	b0
D7	D6	D5	D4	D3	D2	D1	D0
R/W	R/W	R/W	R/W	R/W	R/W	R/W	R/W
x	x	x	x	x	x	x	x

I/O port PORTE is also accessed using an SFR, but unlike the PORTA-PORTD SFRs, it is not bit-addressable.

Use OR to set bit 3:

```
mov a, IOE
or a, #00001000b ; set bit 3
mov IOE, a
```

OEA							Port A Output Enable	SFR 0xB2
b7	b6	b5	b4	b3	b2	b1	b0	
D7	D6	D5	D4	D3	D2	D1	D0	
R/W	R/W	R/W	R/W	R/W	R/W	R/W	R/W	
0	0	0	0	0	0	0	0	

OEB							Port B Output Enable	SFR 0xB3
b7	b6	b5	b4	b3	b2	b1	b0	
D7	D6	D5	D4	D3	D2	D1	D0	
R/W	R/W	R/W	R/W	R/W	R/W	R/W	R/W	
0	0	0	0	0	0	0	0	

OEC							Port C Output Enable	SFR 0xB4
b7	b6	b5	b4	b3	b2	b1	b0	
D7	D6	D5	D4	D3	D2	D1	D0	
R/W	R/W	R/W	R/W	R/W	R/W	R/W	R/W	
0	0	0	0	0	0	0	0	

OED							Port D Output Enable	SFR 0xB5
b7	b6	b5	b4	b3	b2	b1	b0	
D7	D6	D5	D4	D3	D2	D1	D0	
R/W	R/W	R/W	R/W	R/W	R/W	R/W	R/W	
0	0	0	0	0	0	0	0	

OEE							Port E Output Enable	SFR 0xB6
b7	b6	b5	b4	b3	b2	b1	b0	
D7	D6	D5	D4	D3	D2	D1	D0	
R/W	R/W	R/W	R/W	R/W	R/W	R/W	R/W	
0	0	0	0	0	0	0	0	

The bits in 0EA - 0EE turn on the output buffers for the five I/O Ports PORTA-PORTE. Set a bit to '1' to turn on the output buffer, set it to '0' to turn the buffer off.

EP01STAT							Endpoint 0 and 1 Status	SFR 0xBA
b7	b6	b5	b4	b3	b2	b1	b0	
0	0	0	0	0	EP1INBSY	EP1OUTBSY	EP0BSY	
R	R	R	R	R	R	R	R	
0	0	0	0	0	0	0	0	

Endpoint 2,4,6,8 GPIF Slave							SFR 0xBB
GPIFTRIG see Section 15.15							
b7	b6	b5	b4	b3	b2	b1	b0
DONE	0	0	0	0	R/W	EP1	EP0
R/W	R	R	R	R	R/W	R/W	R/W
1	0	0	0	0	x	x	x

GPIF Data HIGH (16-bit mode only)							SFR 0xBD
GPIFSGLDATH							
b7	b6	b5	b4	b3	b2	b1	b0
D15	D14	D13	D12	D11	D10	D9	D8
R/W	R/W	R/W	R/W	R/W	R/W	R/W	R/W
x	x	x	x	x	x	x	x

GPIF Data Low w/Trigger							SFR 0xBE
GPIFSGLDATLX							
b7	b6	b5	b4	b3	b2	b1	b0
D7	D6	D5	D4	D3	D2	D1	D0
R/W	R/W	R/W	R/W	R/W	R/W	R/W	R/W
x	x	x	x	x	x	x	x

GPIF Data Low w/No Trigger							SFR 0xBF
GPIFSGLDATLNOX							
b7	b6	b5	b4	b3	b2	b1	b0
D7	D6	D5	D4	D3	D2	D1	D0
R	R	R	R	R	R	R	R
x	x	x	x	x	x	x	x

Most of these SFR registers are also accessible in external RAM space, at the addresses shown in [Table 15-3](#).

Table 15-3. SFR Registers and External Ram Equivalent

SFR Register Name	Hex	External Ram Register Address and Name	
EP2468STAT	AA	E6A3-E6A6	EPxCS
EP24FIFOFLGS	AB	E6A7-E6AA	EPxFIFOFLGS
EP68FIFOFLGS	AC		
EP01STAT	BA	E6A0-E6A2	EP0CS, EP1OUTCS, EP1INCS
GPIFTRIG	BB	E6D4, E6DC, E6E4, E6EC	EPxGPIFTRIG
GPIFSGLDATH	BD	E6F0	XGPIFSGLDATH
GPIFSGLDATLX	BE	E6F1	XGPIFSGLDATLX
GPIFSGLDATLNOX	BF	E6F2	XGPIFSGLDATLNOX

15.4 GPIF Waveform Memories

15.4.1 WAVEDATA

GPIF Waveform Descriptor Data Register

WAVEDATA		GPIF Waveform Descriptor 0, 1, 2, 3 Data						E400-E47F*
b7	b6	b5	b4	b3	b2	b1	b0	
D7	D6	D5	D4	D3	D2	D1	D0	
R/W	R/W	R/W	R/W	R/W	R/W	R/W	R/W	
x	x	x	x	x	x	x	x	

*Accessible only when IFCFG1:0 = 10.

The four GPIF waveform descriptor tables are stored in this space. See the [General Programmable Interface](#) chapter on [page 121](#) for details.

15.5 General Configuration Registers

15.5.1 CPUCS

CPU Control and Status Register

CPUCS		CPU Control and Status						E600
b7	b6	b5	b4	b3	b2	b1	b0	
0	0	PORTCSTB	CLKSPD1	CLKSPD0	CLKINV	CLKOE	8051RES	
R	R	R/W	R/W	R/W	R/W	R/W	R	
0	0	0	0	0	0	1	0	

Bit	Name	Description															
5	PORTCSTB	<p>PORTC access generates \overline{RD} and \overline{WR} strobes.</p> <p>The 100- and 128-pin EZ-USB packages have two output pins, \overline{RD} and \overline{WR}, that can be used to synchronize data transfers on I/O PORTC. When PORTCSTB=1, this feature is enabled. Any read of PORTC activates a \overline{RD} strobe, and any write to PORTC activates a \overline{WR} strobe. The \overline{RD} and \overline{WR} strobes are asserted for two CLKOUT cycles; the WR strobe asserts two CLKOUT cycles after the PORTC pins are updated.</p> <p>If a design uses the 128-pin EZ-USB and connects off-chip memory to the address and data buses, this bit should be set to zero. This is because the \overline{RD} and \overline{WR} pins are also the standard strobes used to read and write off-chip memory, so normal reads/writes to I/O Port C disrupt normal accesses to that memory.</p>															
4:3	CLKSPD[1:0]	<p>CPU Clock Speed</p> <table border="1"> <thead> <tr> <th>CLKSPD1</th> <th>CLKSPD0</th> <th>CPU Clock</th> </tr> </thead> <tbody> <tr> <td>0</td> <td>0</td> <td>12 MHz (Default)</td> </tr> <tr> <td>0</td> <td>1</td> <td>24 MHz</td> </tr> <tr> <td>1</td> <td>0</td> <td>48 MHz</td> </tr> <tr> <td>1</td> <td>1</td> <td>Reserved</td> </tr> </tbody> </table> <p>These bits set the CPU clock speed. On a hard reset, these bits default to '00' (12 MHz). Firmware may modify these bits at any time.</p>	CLKSPD1	CLKSPD0	CPU Clock	0	0	12 MHz (Default)	0	1	24 MHz	1	0	48 MHz	1	1	Reserved
CLKSPD1	CLKSPD0	CPU Clock															
0	0	12 MHz (Default)															
0	1	24 MHz															
1	0	48 MHz															
1	1	Reserved															
2	CLKINV	<p>Invert CLKOUT Signal.</p> <p>0 CLKOUT signal not inverted (as shown in all timing diagrams).</p> <p>1 CLKOUT signal inverted.</p>															
1	CLKOE	<p>Drive CLKOUT Pin.</p> <p>0 CLKOUT pin floats.</p> <p>1 CLKOUT pin driven.</p>															
0	8051RES	<p>8051 Reset.</p> <p>The USB host writes '1' to this bit to reset the 8051, and '0' to run the 8051. Only the USB host writes to this bit (via the 0xA0 firmware load command).</p>															

15.5.2 IFCONFIG

Interface Configuration (Ports, GPIF, Slave FIFOs) Register

IFCONFIG							Interface Configuration(Ports, GPIF, slave FIFOs)	E601
b7	b6	b5	b4	b3	b2	b1	b0	
IFCLKSRC	3048MHZ	IFCLKOE	IFCLKPOL	ASYNC	GSTATE	IFCFG1	IFCFG0	
R/W	R/W	R/W	R/W	R/W	R/W	R/W	R/W	
1	0	0	0	0	0	0	0	

Bit	Name	Description
7	IFCLKSRC	FIFO/GPIF Clock Source. This bit selects the clock source for both the FIFOS and GPIF. 0 The external clock on the IFCLK pin is selected. 1 An internal 30 or 48 MHz (default) clock is used (default).
6	3048MHZ	Internal FIFO/GPIF Clock Frequency This bit selects the internal FIFO and GPIF clock frequency. 0 30 MHz (default) 1 48 MHz
5	IFCLKOE	IFCLK pin output enable. 0 Tri-state 1 Drive
4	IFCLKPOL	Invert the IFCLK signal. This bit indicates that the IFCLK signal is inverted. 0 The clock has the polarity shown in all the timing diagrams in this manual. 1 The clock is inverted.

Figure 15-1. IFCLK Configuration

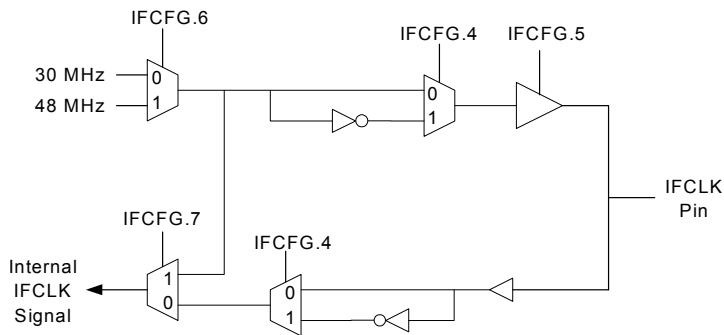

3	ASYNC	Slave FIFO Asynchronous Mode. 0 The Slave FIFOs operate synchronously. A clock is supplied either internally or externally on the IFCLK pin; the FIFO control signals function as read and write enable signals for the clock signal. 1 The Slave FIFOs operate asynchronously. No clock signal input to IFCLK is required; the FIFO control signals function directly as read and write strobes.
---	--------------	---------------------------------------------------------------------------------------------------------------------------------------------------------------------------------------------------------------------------------------------------------------------------------------------------------------------------------------------------------------------------------------------------------

(continued on next page)

15.5.2 IFCONFIG (continued)

- 2 GSTATE** Drive GSTATE [2:0] on PORTE [2:0]. When GSTATE = 1, three bits in Port E take on the signals shown below. The GSTATE bits, which indicate GPIF states, are used for diagnostic purposes.

I/O Pin	Alternate Function
PE0	GSTATE[0]
PE1	GSTATE[1]
PE2	GSTATE[2]

- 1:0 IFCFG[1:0]** Select Interface Mode (Ports, GPIF, or Slave FIFO)
- 00 Ports
 - 01 Reserved
 - 10 GPIF Interface (internal master)
 - 11 Slave FIFO Interface (external master)

These bits control the following EZ-USB interface signals, as shown below.

IFCFG[1:0] = 00 (Ports)	IFCFG[1:0] = 10 (GPIF Master)	IFCFG[1:0] = 11 (Slave FIFO)
PD7	FD[15]	FD[15]
PD6	FD[14]	FD[14]
PD5	FD[13]	FD[13]
PD4	FD[12]	FD[12]
PD3	FD[11]	FD[11]
PD2	FD[10]	FD[10]
PD1	FD[9]	FD[9]
PD0	FD[8]	FD[8]
PB7	FD[7]	FD[7]
PB6	FD[6]	FD[6]
PB5	FD[5]	FD[5]
PB4	FD[4]	FD[4]
PB3	FD[3]	FD[3]
PB2	FD[2]	FD[2]
PB1	FD[1]	FD[1]
PB0	FD[0]	FD[0]
INT0/PA0	INT0/PA0	INT0/PA0
INT1/PA1	INT1/PA1	INT1/PA1
PA2	PA2	SLOE
WU2/PA3	WU2/PA3	WU2/PA3
PA4	PA4	FIFOADR0
PA5	PA5	FIFOADR1
PA6	PA6	PKTEND
PA7	PA7	PA7/FLAGD/ $\overline{\text{SLCS}}$
PC7:0	PC7:0	PC7:0
PE7:0	PE7:0	PE7:0

Note Signals shown in bold type do not change with IFCFG; they are shown for completeness.

15.5.3 PINFLAGSxx

Slave FIFO FLAGA-FLAGD Pin Configuration Registers

PINFLAGSAB Slave FIFO FLAGA and FLAGB Pin Configuration E602							
see Section 15.15							
b7	b6	b5	b4	b3	b2	b1	b0
FLAGB3	FLAGB2	FLAGB1	FLAGB0	FLAGA3	FLAGA2	FLAGA1	FLAGA0
R/W	R/W	R/W	R/W	R/W	R/W	R/W	R/W
0	0	0	0	0	0	0	0

PINFLAGSCD Slave FIFO FLAGC and FLAGD Pin Configuration E603							
see Section 15.15							
b7	b6	b5	b4	b3	b2	b1	b0
FLAGD3	FLAGD2	FLAGD1	FLAGD0	FLAGC3	FLAGC2	FLAGC1	FLAGC0
R/W	R/W	R/W	R/W	R/W	R/W	R/W	R/W
0	0	0	0	0	0	0	0

EZ-USB has four FIFO flag output pins, FLAGA, FLAGB, FLAGC and FLAGD. These flags can be programmed to represent various FIFO flags using four select bits for each FIFO. The PINFLAGSAB register controls the FLAGA and FLAGB signals, and the PINFLAGSCD register controls the FLAGC and FLAGD signal. The four bit coding for all four flags is the same, as shown in Table 15-4 on page 223. In the 'FLAGx' notation, 'x' can be A, B, C or D.

Table 15-4. FIFO Flag Pin Functions

FLAGx3	FLAGx2	FLAGx1	FLAGx0	Pin Function
0	0	0	0	FLAGA=PF, FLAGB=FF, FLAGC=EF, FLAGD=EP2PF (Actual FIFO is selected by FIFOADR[0,1] pins)
0	0	0	1	Reserved
0	0	1	0	
0	0	1	1	
0	1	0	0	EP2 PF
0	1	0	1	EP4 PF
0	1	1	0	EP6 PF
0	1	1	1	EP8 PF
1	0	0	0	EP2 EF
1	0	0	1	EP4 EF
1	0	1	0	EP6 EF
1	0	1	1	EP8 EF
1	1	0	0	EP2 FF
1	1	0	1	EP4 FF
1	1	1	0	EP6 FF
1	1	1	1	EP8 FF

Note FLAGD defaults to EP2PF (fixed flag).

(continued on next page)

15.5.3 PINFLAGSxx (continued)

For the default (0000) selection, the four FIFO flags are indexed as shown in the first table entry. The input pins FIFOADR1 and FIFOADR0 select to which of the four FIFOs the flags correspond. These pins are decoded as follows:

FIFOADR1 Pin	FIFOADR0 Pin	Selected FIFO
0	0	EP2
0	1	EP4
1	0	EP6
1	1	EP8

For example, if FLAGA[3:0]=0000 and the FIFO address pins are driven to [01], then FLAGA is the EP4-Programmable Flag, FLAGB is the EP4-Full Flag, and FLAGC is the EP4-Empty Flag, and FLAGD defaults as PA7. Set PORTACFG.7 = 1 to use FLAGD which by default is EP2PF(fixed flag).

The other (non-zero) values of FLAGx[3:0] allow the designer to independently configure the four flag outputs FLAGA-FLAGD to correspond to any flag—Programmable, Full, or Empty—from any of the four endpoint FIFOS. This allows each flag to be assigned to any of the four FIFOS, including those not currently selected by the FIFOADDR pins. For example, external logic could be filling the EP2IN FIFO with data while also checking the full flag for the EP4OUT FIFO.

15.5.4 FIFORESET

FIFO Reset Register

FIFORESET see Section 15.15		Restore FIFOs to Default State						E604
b7	b6	b5	b4	b3	b2	b1	b0	
NAKALL	0	0	0	EP3	EP2	EP1	EP0	
W	W	W	W	W	W	W	W	
x	x	x	x	x	x	x	x	

Write 0x80 to this register to NAK all transfers from the host, then write 0x82, 0x84, 0x86, or 0x88 to continue to NAKALL and reset an individual FIFO. This will restore endpoint FIFO flags and byte counts to their default states. Write 0x00 to restore normal operation.

Bit	Name	Description
7	NAKALL	NAK all. NAK all transfers from the host.
3:0	EP3:0	Endpoint. By writing the desired endpoint number (2,4,6,8), EZ-USB logic resets the individual endpoint.

15.5.5 BREAKPT

Breakpoint Register

BREAKPT		Breakpoint Control					E605	
b7	b6	b5	b4	b3	b2	b1	b0	
0	0	0	0	BREAK	BPPULSE	BPEN	0	
R	R	R	R	R/W	R/W	R/W	R	
0	0	0	0	0	0	0	0	

Bit	Name	Description
3	Break	<p>Enable Breakpoint.</p> <p>The BREAK bit is set when the CPU address bus matches the address held in the bit breakpoint address registers (0xE606/07). The BKPT pin reflects the state of this bit. Write a '1' to the BREAK bit to clear it. It is not necessary to clear the BREAK bit if the pulse mode bit (BPPULSE) is set.</p>
2	BPPULSE	<p>Breakpoint Pulse Mode.</p> <p>Set this bit to '1' to pulse the BREAK bit (and BKPT pin) high for eight CLKOUT cycles when the 8051 address bus matches the address held in the breakpoint address registers. When this bit is set to '0', the BREAK bit (and BKPT pin) remains high until it is cleared by firmware.</p>
1	BPEN	<p>Breakpoint Enable.</p> <p>If this bit is '1', a BREAK signal is generated whenever the 16 bit address lines match the value in the Breakpoint Address registers (BPADDRH:L). The behavior of the BREAK bit and associated BKP pin signal is either latched or pulsed, depending on the state of the BPPULSE bit.</p>

15.5.6 BPADDRx

Breakpoint Address High, Breakpoint Address Low Registers

BPADDRH								Breakpoint Address High								E606
b7	b6	b5	b4	b3	b2	b1	b0	b7	b6	b5	b4	b3	b2	b1	b0	
A15	A14	A13	A12	A11	A10	A9	A8	A15	A14	A13	A12	A11	A10	A9	A8	
R/W	R/W	R/W	R/W	R/W	R/W	R/W	R/W	R/W	R/W	R/W	R/W	R/W	R/W	R/W	R/W	
x	x	x	x	x	x	x	x	x	x	x	x	x	x	x	x	

BPADDRL								Breakpoint Address Low								E607
b7	b6	b5	b4	b3	b2	b1	b0	b7	b6	b5	b4	b3	b2	b1	b0	
A7	A6	A5	A4	A3	A2	A1	A0	A7	A6	A5	A4	A3	A2	A1	A0	
R/W	R/W	R/W	R/W	R/W	R/W	R/W	R/W	R/W	R/W	R/W	R/W	R/W	R/W	R/W	R/W	
x	x	x	x	x	x	x	x	x	x	x	x	x	x	x	x	

Bit	Name	Description
15:0	A[15:0]	High and Low Breakpoint Address. When the current 16 bit address (code or XDATA) matches the BPADDRH/BPADDRL address, a breakpoint event occurs. The BPPULSE and BPEN bits in the BREAKPT register control the action taken on a breakpoint event.

15.5.7 UART230

230K Baud Clock (T0, T1, T2) Register

UART230		230K Baud Clock for T1						E608	
b7	b6	b5	b4	b3	b2	b1	b0		
0	0	0	0	0	0	230UART1	230UART0		
R	R	R	R	R	R	R/W	R/W		
0	0	0	0	0	0	0	0		

Bit	Name	Description
1:0	230UART[1:0]	Set 230K Baud Operation. Setting these bits to '1' overrides the timer inputs to the USARTs, and USART0 and USART1 use the 230K baud clock rate. This mode provides the correct frequency to the USART regardless of the CPU clock frequency (12, 24, or 48 MHz).

15.5.8 FIFOINPOLAR

Slave FIFO Interface Pins Polarity Register

FIFOPINPOLAR see Section 15.15		Slave FIFO Interface Pins Polarity						E609
b7	b6	b5	b4	b3	b2	b1	b0	
0	0	PKTEND	SLOE	SLRD	SLWR	EF	FF	
R	R	R/W	R/W	R/W	R/W	R/W	R/W	
0	0	0	0	0	0	0	0	

Bit	Name	Description
5	PKTEND	FIFO Packet End Polarity. This bit selects the polarity of the PKTEND FIFO input pin. 0 Selects the polarity shown in the data sheet (active low) 1 Selects active high
4	SLOE	FIFO Output Enable Polarity. This bit selects the polarity of the SLOE FIFO input pin. 0 Selects the polarity shown in the data sheet (active low) 1 Selects active high
3	SLRD	FIFO Read Polarity. This bit selects the polarity of the SLRD FIFO input pin. 0 Selects the polarity shown in the data sheet (active low) 1 Selects active high
2	SLWR	FIFO Write Polarity. This bit selects the polarity of the SLWR FIFO input pin. 0 Selects the polarity shown in the data sheet (active low) 1 Selects active high
1	EF	Empty Flag Polarity. This bit selects the polarity of the Empty Flag output pin. 0 Selects the polarity shown in the data sheet (active low) 1 Selects active high
0	FF	Full Flag Polarity. This bit selects the polarity of the Full Flag output pin. 0 Selects the polarity shown in the data sheet (active low) 1 Selects active high.

15.5.9 REVID

Chip Revision ID Register

REVID		Chip Revision ID						E60A
b7	b6	b5	b4	b3	b2	b1	b0	
RV7	RV6	RV5	RV4	RV3	RV2	RV1	RV0	
R	R	R	R	R	R	R	R	
0	0	0	0	0	0	0	1	

Bit	Name	Description
7:0	RV[7:0]	Chip Revision Number. These register bits define the silicon revision.

15.5.10 REVCTL

Chip Revision Control Register

REVCTL		Chip Revision Control						E60B	
See Section 15.15		b7	b6	b5	b4	b3	b2	b1	b0
0	0	0	0	0	0	0	0	DYN_OUT	ENH_PKT
R	R	R	R	R	R	R	R	R/W	R/W
0	0	0	0	0	0	0	0	0	0

Note DYN_OUT and ENH_PKT default to '0' on a hard reset. Cypress highly recommends setting both bits to '1'.

Bit	Name	Description
1	DYN_OUT	<p>Disable Auto-Arming at the 0-1 transition of AUTOOUT.</p> <p>0 The core automatically arms the endpoints when AUTOOUT is switched from '0' to '1'. This means that firmware must reset the endpoint (and risk losing endpoint data) when switching between Auto-Out mode and Manual-Out mode.</p> <p>1 The core disables auto-arming of the endpoints when AUTOOUT transitions from '0' to '1'. This feature allows CPU intervention when switching between AUTO and Manual mode without having to reset the endpoint.</p> <p>Note When DYN_OUT = 1 and AUTOOUT = 1, the CPU is responsible for 'priming the pump' by initially arming the endpoints (OUTPKTEND w/SKIP = 1 to pass packets to host).</p>
0	ENH_PKT	<p>Enhanced Packet Handling.</p> <p>0 The CPU can neither source OUT packets nor skip IN packets; it has only the following capabilities: OUT packets: Skip or Commit IN packets: Commit or Edit/Source</p> <p>1 The CPU has additional capabilities: OUT packets: Skip, Commit, or Edit/Source IN packets: Skip, Commit, or Edit/Source</p>

E60C

15.5.11 GPIFHOLDAMOUNT

GPIF Hold Time Register

GPIFHOLDAMOUNT							E60C	
b7	b6	b5	b4	b3	b2	b1	b0	
0	0	0	0	0	0	HOLDTIME[1:0]		
R	R	R	R	R	R	RW	RW	
0	0	0	0	0	0	0	0	

For any transaction where the GPIF writes data onto FD[15:0], this register determines how long the data is held. Valid choices are '0', '½', or '1' IFCLK cycle. This register applies to any data written by the GPIF to FD[15:0], whether through a flow state or not.

For non-flow states, the hold amount is really just a delay of the normal (non-held) presentation of FD[15:0] by the amount specified in HOLDTIME[1:0].

For flow states in which the GPIF is the master on the bus (FLOWSTB.SLAVE = 0), the hold amount is with respect to the activating edge (see FLOW_MASTERSTB_EDGE) of Master strobe (which is a CTL pin in this case).

For flow states in which the GPIF is the slave on the bus (FLOWSTB.SLAVE = 1), the hold amount is really just a delay of the normal (non-held) presentation of FD[15:0] by the amount specified in HOLDTIME[1:0] in reaction to the activating edge of master strobe (which is a RDY pin in this case). Note the hold amount is NOT directly with respect to the activating edge of master Strobe in this case. It is with respect to when the data normally comes out in response to master strobe including any latency to synchronize master strobe.

In all cases, the data is held for the desired amount even if the ensuing GPIF state calls for the data bus to be tri-stated. In other words the FD[15:0] output enable is held by the same amount as the data itself.

Bit	Name	Description
1:0	HOLDTIME[1:0]	GPIF Hold Time. 00 0 IFCLK cycles 01 ½ IFCLK cycle 10 1 IFCLK cycle 11 Reserved

15.6 Endpoint Configuration

15.6.1 EP1OUTCFG

Endpoint 1-OUT Configuration Register

EP1OUTCFG		Endpoint 1-OUT Configuration						E610
b7	b6	b5	b4	b3	b2	b1	b0	
VALID	0	TYPE1	TYPE0	0	0	0	0	
R/W	R	R/W	R/W	R	R	R	R	
1	0	1	0	0	0	0	0	

Bit	Name	Description
7	VALID	Activate an Endpoint. Set VALID=1 to activate an endpoint, and VALID=0 to de-activate it. All EZ-USB endpoints default to VALID. An endpoint whose VALID bit is '0' does not respond to any USB traffic.
5:4	TYPE[1:0]	Defines the Endpoint Type. 00 Invalid 01 Invalid 10 Bulk (default) 11 Interrupt

15.6.2 EP1INCFG

Endpoint 1-IN Configuration Register

EP1INCFG		Endpoint 1-IN Configuration						E611
b7	b6	b5	b4	b3	b2	b1	b0	
VALID	0	TYPE1	TYPE0	0	0	0	0	
R/W	R	R/W	R/W	R	R	R	R	
1	0	1	0	0	0	0	0	

Bit	Name	Description
7	VALID	Activate an Endpoint. Set VALID=1 to activate an endpoint, and VALID=0 to de-activate it. All EZ-USB endpoints default to VALID. An endpoint whose VALID bit is '0' does not respond to any USB traffic.
5:4	TYPE[1:0]	Defines the Endpoint Type. 00 Invalid 01 Invalid 10 Bulk (default) 11 Interrupt

15.6.3 EPxCFG

Endpoint 2, 4, 6 and 8 Configuration Registers

EP2CFG							Endpoint 2 Configuration		E612
b7	b6	b5	b4	b3	b2	b1	b0		
VALID	DIR	TYPE1	TYPE0	SIZE	0	BUF1	BUF0		
R/W	R/W	R/W	R/W	R/W	R	R/W	R/W		
1	0	1	0	0	0	1	0		

EP4CFG							Endpoint 4 Configuration		E613
b7	b6	b5	b4	b3	b2	b1	b0		
VALID	DIR	TYPE1	TYPE0	0	0	0	0		
R/W	R/W	R/W	R/W	R	R	R	R		
1	0	1	0	0	0	0	0		

EP6CFG							Endpoint 6 Configuration		E614
b7	b6	b5	b4	b3	b2	b1	b0		
VALID	DIR	TYPE1	TYPE0	SIZE	0	BUF1	BUF0		
R/W	R/W	R/W	R/W	R/W	R	R/W	R/W		
1	1	1	0	0	0	1	0		

EP8CFG							Endpoint 8 Configuration		E615
b7	b6	b5	b4	b3	b2	b1	b0		
VALID	DIR	TYPE1	TYPE0	0	0	0	0		
R/W	R/W	R/W	R/W	R	R	R	R		
1	1	1	0	0	0	0	0		

These registers configure the large, data handling EZ-USB endpoints.

Bit	Name	Description
7	VALID	Activate an Endpoint. 0 Deactivate an endpoint. An endpoint whose VALID bit is 0 does not respond to any USB traffic. 1 Activate an endpoint (default)
6	DIR	Sets Endpoint Direction. 0 OUT 1 IN
5:4	TYPE[1:0]	Defines the Endpoint Type. The TYPE bits apply to all of the large-endpoint configuration registers. 00 Invalid 01 Isochronous 10 Bulk (default) 11 Interrupt
3	SIZE	Sets Size of Endpoint Buffer. Endpoints 4 and 8 can only be 512 bytes. Endpoints 2 and 6 are selectable. 0 512 bytes 1 1024 bytes

(continued on next page)

15.6.3 EPxCFG (continued)

1:0	BUF[1:0]	Buffering Type/Amount.
		00 Quad
		01 Invalid
		10 Double
		11 Triple

Note The Valid bit is ignored when buffer space is allocated by the EZ-USB (for example, BUF[1:0] takes precedence over the Valid bit). When you are not using all of the endpoints in the endpoint configuration, disable the unused endpoints by writing a zero into the “valid” bit of the corresponding EPxCFG register without disturbing the default state of the other bits in the register.

For example, if the endpoint configuration 11 (see [1.17 EZ-USB Endpoint Buffers on page 30](#)), which uses only endpoints 2 and 8, must be used, configure the endpoints as follows.

```
EP2CFG = 0xDB;
SYNCDELAY;
EP8CFG = 0x92;
SYNCDELAY;
EP4CFG &= 0x7F;
SYNCDELAY;
EP6CFG &= 0x7F;
SYNCDELAY;
```

15.6.4 EPxFIFOCFG

Endpoint 2, 4, 6 and 8/Slave FIFO Configuration Registers

EP2FIFOCFG see Section 15.15	Endpoint 2/Slave FIFO Configuration	E618
EP4FIFOCFG see Section 15.15	Endpoint 4/Slave FIFO Configuration	E619
EP6FIFOCFG see Section 15.15	Endpoint 6/Slave FIFO Configuration	E61A
EP8FIFOCFG see Section 15.15	Endpoint 8/Slave FIFO Configuration	E61B

b7	b6	b5	b4	b3	b2	b1	b0
0	INFM1	OEP1	AUTOOUT	AUTOIN	ZEROLENIN	0	WORDWIDE
R	R/W	R/W	R/W	R/W	R/W	R	R/W
0	0	0	0	0	1	0	1

Bit	Name	Description
6	INFM1	<p>IN Full Minus One.</p> <p>When a FIFO configuration register's 'INEARLY' or INFM bit is set to '1', the FIFO flags for that endpoint become valid one sample earlier than when the FULL condition occurs. These bits take effect only when the FIFOs are operating synchronously—according to an internally or externally supplied clock. Having the FIFO flag indications a clock early simplifies some synchronous interfaces (applies only to IN endpoints).</p>
5	OEP1	<p>OUT Empty Plus One.</p> <p>When a FIFO configuration register's 'OUTEARLY' or OEP1 bit is set to '1', the FIFO flags for that endpoint become valid one sample earlier than when the EMPTY condition occurs. These bits take effect only when the FIFOs are operating synchronously—according to an internally or externally supplied clock. Having the FIFO flag indications a clock early simplifies some synchronous interfaces (applies only to OUT endpoints).</p>
4	AUTOOUT	<p>Instantaneous Connection to Endpoint FIFO. This bit applies only to OUT endpoints.</p> <p>0 As soon as a buffer fills with USB data, an endpoint interrupt is asserted. The connection of the buffer to the endpoint FIFO is under control of the firmware, rather than automatically being connected. Using this method, the firmware can inspect the data in OUT packets, and based on what it finds, choose to include that packet in the endpoint FIFO or not. The firmware can even modify the packet data, and <u>then</u> commit it to the endpoint FIFO. Refer to Enhanced Packet Handling in section Chip Revision Control Register on page 231.</p> <p>1 As soon as a buffer fills with USB data, the buffer is automatically and instantaneously committed to the endpoint FIFO bypassing the CPU. The endpoint FIFO flags and buffer counts immediately indicate the change in FIFO status. Refer to the description of the DYN_OUT bit in section Chip Revision Control Register on page 231.</p>

The SKIP bit (in the EPxBCL registers) chooses between skipping and committing packet data. Refer to OUTPKTEND in section [Force OUT Packet End Register on page 255](#).

(continued on next page)

15.6.4 EPxFIFOCFG (continued)

- 3 AUTOIN** Auto Commit to SIE. This bit applies only to IN endpoints. EZ-USB has EPxAUTOINLEN registers that allow the firmware to configure endpoints to sizes smaller than the physical memory sizes used to implement the endpoint buffers (512 or 1024 bytes). For example, suppose the firmware configures the EP2 buffer to be 1024 bytes (this must match the wMaxPacketSize value in the endpoint descriptor), and then sets up EP2 as a 760 byte endpoint by setting EP2AUTOINLEN=760. This makes EP2 appear to be a 760 byte endpoint to the USB host, even though EP2's physical buffer is 1024 bytes.
- 0 Each packet has to initially be manually committed to SIE, (prime the pump). See section [Chip Revision Control Register on page 231](#).
 - 1 EZ-USB automatically packetizes and dispatches IN packets according to the packet length value it finds in the EPxAUTOINLEN registers. In this example, the GPIF (or an external master, if the EZ-USB is in Slave FIFO mode) could load the EP2 buffer with 950 bytes, which the EZ-USB logic would then automatically send as two packets, of 760 and 190 bytes. Refer to Enhanced Packet Handling in section [Chip Revision Control Register on page 231](#).
- 2 ZEROLENIN** Enable Zero length IN Packets.
- 0 Zero length packets are sent on PKTEND.
 - 1 A zero length packet is sent when PKTEND is activated and there are no bytes in the current packet.
- 0 WORDWIDE** Select Byte/Word FIFOs on PORTB/D Pins.
- This bit selects byte or word FIFOs on the PORTB and PORTD pins. The WORD bit applies 'for IFCFG =11 or 10'.
- The OR of all four WORDWIDE bits is what causes PORTD to be PORTD or FD[15:8]. The individual WORDWIDE bits indicate how data is to be passed for each individual endpoint.

15.6.5 EP2AUTOINLENH

Endpoint 2 AUTOIN Packet Length High Register

EP2AUTOINLENH see Section 15.15		Endpoint 2 AUTOIN Packet Length High						E620
b7	b6	b5	b4	b3	b2	b1	b0	
0	0	0	0	0	PL10	PL9	PL8	
R	R	R	R	R	R/W	R/W	R/W	
0	0	0	0	0	0	1	0	

Bit	Name	Description
2:0	PL10:8	Packet Length High. High three bits of Packet Length.

15.6.6 EP6AUTOINLENH

Endpoint 6 AUTOIN Packet Length High Register

EP6AUTOINLENH see Section 15.15		Endpoint 6 AUTOIN Packet Length High						E624
b7	b6	b5	b4	b3	b2	b1	b0	
0	0	0	0	0	PL10	PL9	PL8	
R	R	R	R	R	R/W	R/W	R/W	
0	0	0	0	0	0	1	0	

Bit	Name	Description
2:0	PL[10:8]	Packet Length High. High three bits of Packet Length.

15.6.7 EP4AUTOINLENH

Endpoint 4 AUTOIN Packet Length High Register

EP4AUTOINLENH see Section 15.15		Endpoint 4 AUTOIN Packet Length High						E622
b7	b6	b5	b4	b3	b2	b1	b0	
0	0	0	0	0	0	PL9	PL8	
R	R	R	R	R	R	R/W	R/W	
0	0	0	0	0	0	1	0	

Bit	Name	Description
1:0	PL[9:8]	Packet Length High. High two bits of Packet Length.

E626

15.6.8 EP8AUTOINLENH

Endpoint 8 AUTOIN Packet Length High Register

EP8AUTOINLENH see Section 15.15		Endpoint 8 AUTOIN Packet Length High						E626
b7	b6	b5	b4	b3	b2	b1	b0	
0	0	0	0	0	0	PL9	PL8	
R	R	R	R	R	R	R/W	R/W	
0	0	0	0	0	0	1	0	

Bit	Name	Description
1:0	PL[9:8]	Packet Length High. High two bits of Packet Length.

15.6.9 EPxAUTOINLENL

Endpoint 2, 4, 6, 8 AUTOIN Packet Length Low Registers

EP2AUTOINLENL see Section 15.15		Endpoint 2 AUTOIN Packet Length Low						E621
EP4AUTOINLENL see Section 15.15		Endpoint 4 AUTOIN Packet Length Low						E623
EP6AUTOINLENL see Section 15.15		Endpoint 6 AUTOIN Packet Length Low						E625
EP8AUTOINLENL see Section 15.15		Endpoint 8 AUTOIN Packet Length Low						E627
b7	b6	b5	b4	b3	b2	b1	b0	
PL7	PL6	PL5	PL4	PL3	PL2	PL1	PL0	
R/W	R/W	R/W	R/W	R/W	R/W	R/W	R/W	
0	0	0	0	0	0	0	0	

Bit	Name	Description
7:0	PL[7:0]	<p>Packet Length Low. Low eight bits of packet length.</p> <p>These registers can be used to set smaller packet sizes than the physical buffer size (refer to the previously described EPxCFG registers). The default packet size is 512 bytes for all endpoints. Note that EP2 and EP6 can have maximum sizes of 1024 bytes, and EP4 and EP8 can have maximum sizes of 512 bytes, to be consistent with the endpoint structure.</p>

15.6.10 EPxFIFOPFH

Endpoint 2, 6/Slave FIFO Programmable Level Flag High Registers

EP2FIFOPFH see Section 15.15								Endpoint 2/Slave FIFO Programmable-Level Flag High [High-Speed (480 Mbps) Mode and Full-Speed (12 Mbps) Iso Mode]		E630
b7	b6	b5	b4	b3	b2	b1	b0	Buffer Size		
DECIS	PKTSTAT	IN: PKTS[2]	IN: PKTS[1]	IN: PKTS[0]	0	PFC9	PFC8	1024		
		OUT:PFC12	OUT:PFC11	OUT:PFC10			PFC8	512		
		PFC11	PFC10	PFC9						
R/W	R/W	R/W	R/W	R/W	R	R/W	R/W			
1	0	0	0	1	0	0	0			

EP2FIFOPFH see Section 15.15								Endpoint 2/Slave FIFO Programmable-Level Flag High [Full-Speed (12 Mbps) Non-Iso Mode]		E630
b7	b6	b5	b4	b3	b2	b1	b0	Buffer Size		
DECIS	PKTSTAT	OUT:PFC12	OUT:PFC11	OUT:PFC10	0	PFC9	IN: PKTS[2] OUT:PFC8	64		
R/W	R/W	R/W	R/W	R/W	R	R/W	R/W			
1	0	0	0	1	0	0	0			

EP6FIFOPFH see Section 15.15								Endpoint 6/Slave FIFO Programmable-Level Flag High [High-Speed (480 Mbps) Mode and Full-Speed (12 Mbps) Iso Mode]		E634
b7	b6	b5	b4	b3	b2	b1	b0	Buffer Size		
DECIS	PKTSTAT	IN: PKTS[2]	IN: PKTS[1]	IN: PKTS[0]	0	PFC9	PFC8	1024		
		OUT:PFC12	OUT:PFC11	OUT:PFC10			PFC8	512		
		PFC11	PFC10	PFC9						
R/W	R/W	R/W	R/W	R/W	R/W	R/W	R/W			
0	0	0	0	1	0	0	0			

EP6FIFOPFH see Section 15.15								Endpoint 6/Slave FIFO Programmable-Level Flag High [Full-Speed (12 Mbps) Non-Iso Mode]		E634
b7	b6	b5	b4	b3	b2	b1	b0	Buffer Size		
DECIS	PKTSTAT	OUT:PFC12	OUT:PFC11	OUT:PFC10	0	PFC9	IN: PKTS[2] OUT:PFC8	64		
R/W	R/W	R/W	R/W	R/W	R/W	R/W	R/W			
0	0	0	0	1	0	0	0			

Note Buffer size is in bytes: 64 = Full speed Bulk/Int; 1023 = Full speed ISO, 1024 = High speed ISO/Int; 512 = All others.

These registers control the point at which the programmable flag (PF) is asserted for each of the four endpoint FIFOs. The EPxFIFOPFH:L fields are interpreted differently for OUT and IN endpoints.

The polarity of the programmable flag pin depends on the DECIS bit. If DECIS=0, then PF goes high when the byte count is equal to, or less than what is defined in the PF registers. If DECIS=1, (default) then PF goes high when the byte count is equal to, or greater than what is set in the PF register. For OUT endpoints, the byte count is the total number of bytes in the FIFO that are available to the external master. For IN endpoints, the byte count is determined by PKTSTAT bit as explained below.

(continued on next page)

15.6.10 EPxFIFOPFH (continued)

Each FIFO's programmable-level flag asserts when the FIFO reaches a user-defined fullness threshold. That threshold is configured as follows:

1. For OUT packets: The threshold is stored in PFC12:0. The PF is asserted when the number of bytes in the entire FIFO is less than/equal to (DECIS = 0) or greater than/equal to (DECIS = 1) the threshold.
2. For IN packets, with PKTSTAT = 1: The threshold is stored in PFC9:0. The PF is asserted when the number of bytes written into the current, not-yet-committed packet in the FIFO is less than/equal to (DECIS = 0) or greater than/equal to (DECIS = 1) the threshold.
3. For IN packets, with PKTSTAT = 0: The threshold is stored in two parts: PKTS2:0 holds the number of committed packets, and PFC9:0 holds the number of bytes in the current, not-yet-committed packet. The PF is asserted when the FIFO is at or less full than (DECIS = 0), or at or more full than (DECIS=1), the threshold.

By default, FLAGA is the programmable-level flag for the endpoint currently pointed to by the FIFOADR[1:0] pins. For EP2 and EP4, the default endpoint configuration is BULK, OUT, 512, 2x, and the PF pin asserts when the entire FIFO has greater than/equal to 512 bytes. For EP6 and EP8, the default endpoint configuration is BULK, IN, 512, 2x, and the PF pin asserts when the entire FIFO has less than/equal to 512 bytes.

In other words, the default-configuration PFs for EP2 and EP4 assert when the FIFOs are half-full, and the default configuration PFs for EP6 and EP8 assert when those FIFOs are half-empty.

In the first example below, bits 5-3 have data that is required to complete the transfer. In the second example, bits 5-3 do not matter - those bits are don't cares because PKTSTAT = 1:

Example 1:

Assume a Bulk IN transfer over Endpoint 2 and PKTSTAT = 0:

- EP2FIFOPFH = 0001 0000
 - b6 = 0 (or PKTSTAT = 0): this indicates that the transfer includes packets (as defined by bits 5, 4, and 3) plus bytes (the sum in the flag low register)
 - **b5b4b3** = 010 binary (or 2 decimal): this indicates the number of packets to expect during the transfer (in this case, two packets...)
- EP2FIFOPFL = 0011 0010
 - ...plus 50 bytes in the currently filling packet (the sum of the binary bits in the EP2FIFOPFL register is 2 +16 + 32 = 50 decimal)

DECIS = 0, thus PF activates when the FIFO is at or less full than 2 PKTS + 50 bytes.

Example 2:

To perform an IN transfer of a number over the same endpoint, set PKTSTAT = 1 and write a value into the EP2FIFOPFL register:

- EP2FIFOPFH = 0100 0000
- EP2FIFOPFL = 0100 1011 (75 bytes)

Setting PKTSTAT = 1 causes the PF decision to be based on the byte count alone, ignoring the packet count. This mode is valuable for double-buffered endpoints, where only the byte count of the currently-filling packet is important.

DECIS = 0, thus PF is asserted when the currently filling packet is at or less than 75 bytes.

Bit	Name	Description
1:0	PFC[9:8]	PF Threshold. Bits 1:0 of EP2FIFOPFH are bits 9:8 of the byte count register.

E632

Endpoint 4, 8 Slave FIFO Programmable Level Flag High Registers

EP4FIFOPFH Endpoint 4/Slave FIFO Programmable-Level Flag HIGH **E632**
 see Section [High-Speed (480 Mbps) Mode and Full-Speed (12 Mbps) Iso Mode] 15.15

b7	b6	b5	b4	b3	b2	b1	b0
DECIS	PKTSTAT	0	IN: PKTS[1] OUT:PFC10	IN: PKTS[0] OUT:PFC9	0	0	PFC8
R/W	R/W	R	R/W	R/W	R	R	R/W
1	0	0	0	1	0	0	0

EP4FIFOPFH Endpoint 4/Slave FIFO Programmable-Level Flag HIGH **E632**
 see Section [Full-Speed (12 Mbps) Non-Iso Mode] 15.15

b7	b6	b5	b4	b3	b2	b1	b0
DECIS	PKTSTAT	0	OUT:PFC10	OUT:PFC9	0	0	PFC8
R/W	R/W	R	R/W	R/W	R	R	R/W
1	0	0	0	1	0	0	0

EP8FIFOPFH Endpoint 8/Slave FIFO Programmable-Level Flag HIGH **E636**
 see Section [High-Speed (480 Mbps) Mode and Full-Speed (12 Mbps) Iso Mode] 15.15

b7	b6	b5	b4	b3	b2	b1	b0
DECIS	PKTSTAT	0	IN: PKTS[1] OUT:PFC10	IN: PKTS[0] OUT:PFC9	0	0	PFC8
R/W	R/W	R	R/W	R/W	R	R	R/W
0	0	0	0	1	0	0	0

EP8FIFOPFH Endpoint 8/Slave FIFO Programmable-Level Flag HIGH **E636**
 see Section [Full-Speed (12 Mbps) Non-Iso Mode] 15.15

b7	b6	b5	b4	b3	b2	b1	b0
DECIS	PKTSTAT	0	OUT:PFC10	OUT:PFC9	0	0	PFC8
R/W	R/W	R	R/W	R/W	R	R	R/W
0	0	0	0	1	0	0	0

Refer to the discussion for EP2FIFOPFH.

Bit	Name	Description
7	DECIS	PF Polarity. See EP2FIFOPFH and EP6FIFOPFH register definition.
6	PKTSTAT	Packet Status. See EP2FIFOPFH and EP6FIFOPFH register definition.
Bit 4-3	PKTS1:0 / PFC10:9	PF Threshold. See EP2FIFOPFH and EP6FIFOPFH register definition.
Bit 0	PFC8	PF Threshold. See EP2FIFOPFH and EP6FIFOPFH register definition.

15.6.11 EPxFIFOPFL

Endpoint 2, 4, 6, 8/Slave FIFO Programmable Level Flag Low Registers

EP2FIFOPFL see Section 15.15		Endpoint 2/Slave FIFO Prog. Flag Low						E631
EP4FIFOPFL see Section 15.15		Endpoint 4/Slave FIFO Prog. Flag Low						E633
EP6FIFOPFL see Section 15.15		Endpoint 6/Slave FIFO Prog. Flag Low						E635
EP8FIFOPFL see Section 15.15		Endpoint 8/Slave FIFO Prog. Flag Low [High-Speed (480 Mbps) Mode and Full-Speed (12 Mbps) Iso Mode]						E637
b7	b6	b5	b4	b3	b2	b1	b0	
PFC7	PFC6	PFC5	PFC4	PFC3	PFC2	PFC1	PFC0	
R/W	R/W	R/W	R/W	R/W	R/W	R/W	R/W	
0	0	0	0	0	0	0	0	

EP2FIFOPFL see Section 15.15		Endpoint 2/Slave FIFO Prog. Flag Low						E631
EP4FIFOPFL see Section 15.15		Endpoint 4/Slave FIFO Prog. Flag Low						E633
EP6FIFOPFL see Section 15.15		Endpoint 6/Slave FIFO Prog. Flag Low						E635
EP8FIFOPFL see Section 15.15		Endpoint 8/Slave FIFO Prog. Flag Low [Full-Speed (12 Mbps) Non-Iso Mode]						E637
b7	b6	b5	b4	b3	b2	b1	b0	
IN: PKTS[1] OUT:PFC7	IN: PKTS[0] OUT:PFC6	PFC5	PFC4	PFC3	PFC2	PFC1	PFC0	
R/W	R/W	R/W	R/W	R/W	R/W	R/W	R/W	
0	0	0	0	0	0	0	0	

Bit	Name	Description
7:0	PFC[7:0]	PF Threshold. This register contains the current packet bytes to be transferred when the EPxFIFOPFH register requires data.

Note Bits 9:8 of the byte count are in bits 1:0 of EP2FIFOPFH/EP6FIFOPFH.

Note Bit 8 of the byte count is bit 0 of EP4FIFOPFH/EP8FIFOPFH.

15.6.11.1 IN Endpoints

For IN endpoints, the Trigger registers can apply to either the full FIFO, comprising multiple packets, or only to the current packet being filled. The PKTSTAT bit controls this choice.

Table 15-5. Interpretation of PF for IN Endpoints

PKTSTAT	PF applies to:	EPxFIFOPFH:L format
0	PKTS + Current packet bytes	PKTS[] PBC[]
1	Current packet bytes only	PBC[]

Example 1:

The following is an example of how you might use the first case.

Assume a Bulk IN transfer over Endpoint 2. For Bulk transfers, the EZ-USB packet buffer size is 512 bytes for high-speed mode. Assume you have set up an EP2AUTOINLENH:L value of 100 bytes per packet, and you have configured the endpoint for triple-buffering. This means that whenever 100 bytes are loaded into a packet buffer, the EZ-USB logic commits that packet buffer to the USB interface, essentially adding 100 bytes to the 'USB-side' FIFO.

You want to notify the external logic that is filling the endpoint FIFO under two conditions:

- Two of the three packet buffers are full (committed to sending over USB, but not yet sent).
- The current packet buffer is half-full.

In other words, all available IN endpoint buffer space is almost full. You accomplish this by setting:

- EP2FIFOPFH = 0001 0000
 - b6: PKTSTAT = 0 to include packets plus bytes
 - b5b4b3 = 2: two packets...
- EP2FIFOPFL = 0011 0010
 - ...plus 50 bytes in the currently filling packet

Example 2:

If you want the PF to inform the outside interface (the logic that is filling the IN FIFO) whenever the current packet is 75% full, set PKTSTAT=1, and load a packet byte count of 75:

- EP2FIFOPFH = 1100 0000
- EP2FIFOPFHL = 0100 1011 (75 bytes)

Setting PKTSTAT=1 causes the PF decision to be based on the byte count alone, ignoring the packet count. This mode is valuable for double buffered endpoints, where only the byte count of the currently-filling packet is important.

DECIS=1, thus PF is asserted when the currently filling packet is at or greater than 75 bytes.

15.6.11.2 OUT Endpoints

For OUT endpoints, the PF flag applies to the total number of bytes in the multi-packet FIFO, with no packet count field. Instead of representing byte counts in two segments, a packet count and a byte count for the currently emptying packet, the byte Trigger values indicate total bytes available in the FIFO. Note the discontinuity between PFC10 and PFC9.

Notice that the packet byte counts differ in the upper PFC bits because the endpoints support different FIFO sizes: The EP2 FIFO can be a maximum of 4096 bytes long, the EP6 FIFO can be a maximum of 2048 bytes long, and the EP4 and EP8 FIFOs can be a maximum of 1024 bytes long. The diagram below shows examples of the maximum FIFO sizes.

Figure 15-2. Maximum FIFO Sizes

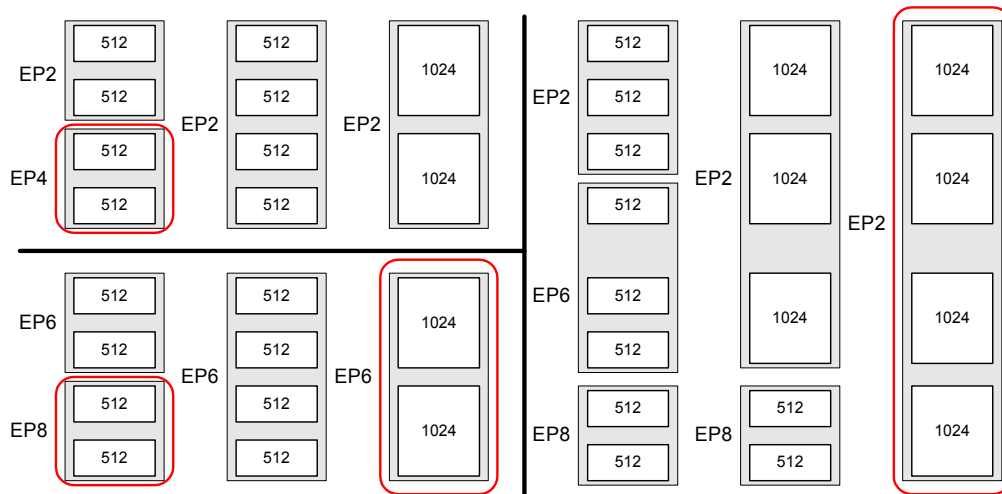

15.6.12 EP2ISOINPKTS

Endpoint 2 ISO IN Packets per Frame Register

EP2ISOINPKTS		Endpoint 2 (if ISO) IN Packets Per Frame						E640
b7	b6	b5	b4	b3	b2	b1	b0	
AADJ	0	0	0	0	0	INPPF1	INPPF0	
R/W	R	R	R	R	R	R/W	R/W	
0	0	0	0	0	0	0	1	

The FX2LP has the capability of sending zero length isochronous data packet (ZLP) when the host issues an IN token to an isochronous IN endpoint FIFO and the SIE does not have any data packets available. A zero length IN packet is automatically sent in the micro-frame if the IN FIFO has no committed packets.

This feature is very useful when designing high bandwidth isochronous applications. When an isochronous IN endpoint is configured for greater than one packet per micro-frame, there is a possibility of the core not having more than one packet available in a micro-frame. In this case, when the host issues an IN token, the FX2LP core automatically sends a zero length packet in response to each of the IN tokens received from the host. Hence avoiding the occurrence of a scenario where the host may encounter a turnaround timeout error on not receiving any data when requesting more than one packet per micro-frame.

In full-speed mode, the EZ-USB only sends one packet per frame, regardless of the EPxISOINPKTS register setting. If the IN endpoint does not have any data packets available, the core automatically sends a zero length packet.

Bit	Name	Description
7	AADJ	<p>Auto Adjust.</p> <p>If AADJ is set to '1', the FX2LP automatically manages the data PID sequencing for high-speed, high-bandwidth isochronous IN endpoints that require additional transactions per micro-frame.</p> <p>Upon receiving the first IN token in the micro-frame, the FX2LP logic evaluates the fullness of committed packets in the IN FIFO. If the logic detects a committed short packet that contains less than 1024 bytes, no further packets beyond the short packet are sent in the micro-frame. If the IN FIFO has no committed packets, then a single zero length packet is sent in the micro-frame.</p> <p>If the IN FIFO is full of 1024 byte packets, then the number of packets sent in the micro-frame is limited by the INPPF[1:0] setting.</p> <p>In both high-speed and full-speed modes, the EZ-USB sends a zero length IN packet if the IN FIFO has no committed packets.</p> <p>If AADJ is set to '0', for IN transactions within the micro-frame, the FX2LP always starts with a data PID corresponding to the number of packets per micro-frame specified in INPPF[1:0]. For example, if INPPF[1:0]=10 (two packets per micro-frame), the FX2LP returns a data PID of DATA1 for the first IN transaction in the micro-frame, even if the data packet is short, or no data is available to be sent for the next IN transaction in the micro-frame.</p> <p>In full-speed mode, the EZ-USB only sends one packet per frame, regardless of the EPxISOINPKTS register setting.</p>
1:0	INPPF[1:0]	<p>IN Packets per Frame.</p> <p>If EP2 is an ISOCHRONOUS IN endpoint, these bits determine the number of packets to be sent per micro-frame (high-speed mode). Allowed values are 1, 2, or 3.</p>

15.6.13 EP4ISOINPKTS

Endpoint 4 ISO IN Packets per Frame Register

EP4ISOINPKTS		Endpoint 4 (if ISO) IN Packets Per Frame						E641	
b7	b6	b5	b4	b3	b2	b1	b0		
AADJ	0	0	0	0	0	INPPF1	INPPF0		
R/W	R	R	R	R	R	R	R		
0	0	0	0	0	0	0	1		

EP4 is not high-bandwidth ISO capable and is only allowed to send up to one packet per micro-frame in high-speed mode, and one packet per frame in full speed mode.

In both high-speed and full-speed modes, EZ-USB sends a zero length IN packet if the IN FIFO has no committed packets.

Bit	Name	Description
7	AADJ	Auto Adjust. If AADJ is set to '1' and the IN FIFO has no committed packets, then a single zero length packet is sent in the micro-frame.
1:0	INPPF[1:0]	IN Packets per Frame. If EP4 is an ISOCHRONOUS IN endpoint, these bits determine the number of packets to be sent per micro-frame (high-speed mode). INPPF1:0 is hardcoded to '01'.

15.6.14 EP6ISOINPKTS

Endpoint 6 ISO IN Packets per Frame Register

EP6ISOINPKTS	Endpoint 6 (if ISO) IN Packets Per Frame						E642	
b7	b6	b5	b4	b3	b2	b1	b0	
AADJ	0	0	0	0	0	INPPF1	INPPF0	
R/W	R	R	R	R	R	R/W	R/W	
0	0	0	0	0	0	0	1	

The FX2LP has the capability of sending zero length isochronous data packet (ZLP) when the host issues an IN token to an isochronous IN endpoint FIFO and the SIE does not have any data packets available. A zero length IN packet is automatically sent in the micro-frame if the IN FIFO has no committed packets.

This feature is very useful when designing high bandwidth isochronous applications. When an isochronous IN endpoint is configured for greater than one packet per micro-frame, there is a possibility of the core not having more than one packet available in a micro-frame. In this case, when the host issues an IN token, the FX2LP core automatically sends a zero length packet in response to each of the IN tokens received from the host. Hence avoiding the occurrence of a scenario where the host may encounter a turnaround time-out error on not receiving any data when requesting more than one packet per micro-frame.

In full-speed mode, the EZ-USB only sends one packet per frame, regardless of the EPxISOINPKTS register setting. If the IN endpoint does not have any data packets available, the core automatically sends a zero length packet.

Bit	Name	Description
7	AADJ	<p>Auto Adjust.</p> <p>If AADJ is set to '1', the FX2LP automatically manages the data PID sequencing for high-speed, high-bandwidth isochronous IN endpoints that require additional transactions per micro-frame.</p> <p>Upon receiving the first IN token in the micro-frame, the FX2LP logic evaluates the fullness of committed packets in the IN FIFO. If the logic detects a committed short packet that contains less than 1024 bytes, no further packets beyond the short packet are sent in the micro-frame. If the IN FIFO has no committed packets, then a single zero length packet is sent in the microframe. If the IN FIFO is full of 1024-byte packets, then the number of packets sent in the micro-frame is limited by the INPPF[1:0] setting.</p> <p>In both high-speed and full-speed modes, the EZ-USB sends a zero length IN packet if the IN FIFO has no committed packets.</p> <p>If AADJ is set to '0', for IN transactions within the micro-frame, the FX2LP always starts with a data PID corresponding to the number of packets per micro-frame specified in INPPF1:0. For example, if INPPF[1:0]=10 (two packets per micro-frame), the FX2LP returns a data PID of DATA1 for the first IN transaction in the micro-frame, even if the data packet is short, or no data is available to be sent for the next IN transaction in the micro-frame.</p> <p>In full-speed mode, the EZ-USB only sends one packet per frame, regardless of the EPxISOINPKTS register setting.</p>
1:0	INPPF[1:0]	<p>IN Packets per Frame</p> <p>If EP6 is an ISOCHRONOUS IN endpoint, these bits determine the number of packets to be sent per micro-frame (high-speed mode). Allowed values are '1' or '2'.</p>

15.6.15 EP8ISOINPKTS

Endpoint 8 ISO IN Packets per Frame Register

EP8ISOINPKTS	Endpoint 8 (if ISO) IN Packets Per Frame						E643
b7	b6	b5	b4	b3	b2	b1	b0
AADJ	0	0	0	0	0	INPPF1	INPPF0
R/W	R	R	R	R	R	R	R
0	0	0	0	0	0	0	1

EP8 is not high bandwidth ISO capable and is only allowed to send up to one packet per micro-frame in high-speed mode, and one packet per frame in full speed mode.

In both high-speed and full-speed modes, EZ-USB sends a zero length IN packet if the IN FIFO has no committed packets.

Bit	Name	Description
7	AADJ	Auto Adjust. If AADJ is set to '1' and the IN FIFO has no committed packets, then a single zero length packet is sent in the micro-frame.
1:0	INPPF[1:0]	IN Packets per Frame. If EP8 is an ISOCHRONOUS IN endpoint, these bits determine the number of packets to be sent per micro-frame (high-speed mode). INPPF[1:0] is hardcoded to '01'.

15.6.16 INPKTEND

Force IN Packet End Register

INPKTEND							Force IN Packet End	E648
see Section 15.15								
b7	b6	b5	b4	b3	b2	b1	b0	
SKIP	0	0	0	EP3	EP2	EP1	EP0	
W	W	W	W	W	W	W	W	
x	x	x	x	x	x	x	x	

Bit	Name	Description
7	SKIP	<p>Skip Packet.</p> <p>When ENH_PKT (REVCTL.0) is set to '1', setting this bit to a '1' causes the IN packet to be skipped. Clearing this bit to '0' automatically dispatches an IN buffer.</p>
3:0	EP[3:0]	<p>Endpoint Number. Duplicates the function of the PKTEND pin. This feature is used only for IN transfers.</p> <p>By writing the desired endpoint number (2, 4, 6 or 8), EZ-USB logic automatically dispatches an IN buffer, for example, it commits the packet to the USB logic, and writes the accumulated byte count to the endpoint's byte count register, thus arming the IN transfer.</p>

15.6.17 OUTPKTEND

Force OUT Packet End Register

OUTPKTEND							Force OUT Packet End	E649
see Section 15.15								
b7	b6	b5	b4	b3	b2	b1	b0	
SKIP	0	0	0	EP3	EP2	EP1	EP0	
W	W	W	W	W	W	W	W	
x	x	x	x	x	x	x	x	

Bit	Name	Description
7	SKIP	Skip Packet. When ENH_PKT (REVCTL.0) is set to '1', setting this bit to a '1' causes the OUT packet to be skipped. Clearing this bit to '0' automatically dispatches an OUT buffer.
3:0	EP[3:0]	Endpoint Number. Replaces the function of EPxBCL.7=1 (Skip). This feature is for OUT transfers. By writing the desired endpoint number (2, 4, 6, or 8), EZ-USB logic automatically skips or commits an OUT packet (depends on the SKIP bit settings).

Note This register has no effect if REVCTL.0 = 0.

15.7 Interrupts

15.7.1 EPxFIFOIE

Endpoint 2, 4, 6, 8 Slave FIFO Flag Interrupt Enable Registers

EP2FIFOIE see Section 15.15		EP2 Slave FIFO Flag Interrupt Enable (INT4)				E650	
EP4FIFOIE see Section 15.15		EP4 Slave FIFO Flag Interrupt Enable (INT4)				E652	
EP6FIFOIE see Section 15.15		EP6 Slave FIFO Flag Interrupt Enable (INT4)				E654	
EP8FIFOIE see Section 15.15		EP8 Slave FIFO Flag Interrupt Enable (INT4)				E656	
b7	b6	b5	b4	b3	b2	b1	b0
0	0	0	0	EDGEPF	PF	EF	FF
R/W	R/W	R/W	R/W	R/W	R/W	R/W	R/W
0	0	0	0	0	0	0	0

The Interrupt registers control all the EZ-USB Interrupt Enables (IE) and Interrupt requests (IRQ). Interrupt enables and request bits for endpoint FIFO: Programmable Flag (PF), Empty Flag (EF), and Full Flag (FF).

To enable any of these interrupts, INTSETUP.1 (INT4SRC) and INTSETUP.0 must be '1'.

Bit	Name	Description
3	EDGEPF	Firing Edge Programmable Flag. 0 The interrupt fires on the rising edge of the programmable flag. 1 The interrupt fires on the falling edge of the programmable flag. Note In order for the CPU to vector to the appropriate interrupt service routine, PF must be set to a '1' and INTSETUP.0=1 (AV4EN) and INTSETUP.1=1 (INT4SRC). Refer to section INT 2 and INT 4 Setup Register on page 274
2	PF	Programmable Flag. 0 The programmable flag interrupt is disabled. 1 The programmable flag interrupt is enabled on INT4.
1	EF	Empty Flag. 0 The empty flag interrupt is disabled. 1 The empty flag interrupt is enabled on INT4.
0	FF	Full Flag. 0 The full flag interrupt is disabled. 1 The full flag interrupt is enabled on INT4.

15.7.2 EPxFIFOIRQ

Endpoint 2, 4, 6, 8 Slave FIFO Flag Interrupt Request Registers

EP2FIFOIRQ see Section 15.15	EP2 Slave FIFO Flag Interrupt Request (INT4)	E651
EP4FIFOIRQ see Section 15.15	EP4 Slave FIFO Flag Interrupt Request (INT4)	E653
EP6FIFOIRQ see Section 15.15	EP6 Slave FIFO Flag Interrupt Request (INT4)	E655
EP8FIFOIRQ see Section 15.15	EP8 Slave FIFO Flag Interrupt Request (INT4)	E657

b7	b6	b5	b4	b3	b2	b1	b0
0	0	0	0	0	PF	EF	FF
R	R	R	R	R	R/W	R/W	R/W
0	0	0	0	0	0	0	0

These are the Interrupt enables and request bits for endpoint FIFO: Programmable Flag (PF), Empty Flag (EF), and Full Flag (FF).

Bit	Name	Description
2	PF	Programmable Flag. EZ-USB sets PF to '1' to indicate a 'programmable flag' interrupt request. The interrupt source is available in the interrupt vector register IVEC4.
1	EF	Empty Flag. EZ-USB sets EF to '1' to indicate an 'empty flag' interrupt request. The interrupt source is available in the interrupt vector register IVEC4.
0	FF	Full Flag. EZ-USB sets FF to '1' to indicate a 'full flag' interrupt request. The interrupt source is available in the interrupt vector register IVEC4. Note Do not clear an IRQ bit by reading an IRQ register, OR'ing its contents with a bit mask, and writing back the IRQ register. This clears all pending interrupts. Instead, simply write the bit mask value (with a '1' in the bit position of the IRQ you want to clear) directly to the IRQ register.

15.7.3 IBNIE

IN-BULK-NAK Interrupt Enable Register

IBNIE IN-BULK-NAK Interrupt Enable (INT2) E658							
b7	b6	b5	b4	b3	b2	b1	b0
0	0	EP8	EP6	EP4	EP2	EP1	EP0
R/W	R/W	R/W	R/W	R/W	R/W	R/W	R/W
0	0	0	0	0	0	0	0

Bit	Name	Description
5:0	EP[8,6,4,2,1,0]	<p>Endpoint Specific Interrupt Enable.</p> <p>These interrupts occur when the host sends an IN token to a Bulk-IN endpoint which has not been loaded with data and armed for USB transfer. In this case the EZ-USB SIE automatically NAKs the IN token and sets the IBNIRQ bit for the endpoint.</p> <p>Set IE=1 to enable the interrupt, and IE=0 to disable it.</p> <p>An IRQ bit is set to '1' to indicate an interrupt request. The interrupt source is available in the interrupt vector register IVEC2. Note The firmware clears an IRQ bit by writing a '1' to it.</p> <p>Note Do not clear an IRQ bit by reading an IRQ register, OR'ing its contents with a bit mask, and writing back the IRQ register. This clears all pending interrupts. Instead, simply write the bit mask value (with a '1' in the bit position of the IRQ you want to clear) directly to the IRQ register.</p>

15.7.4 IBNIRQ

IN-BULK-NAK Interrupt Request Register

IBNIRQ		IN-BULK-NAK Interrupt Request (INT2)						E659
b7	b6	b5	b4	b3	b2	b1	b0	
0	0	EP8	EP6	EP4	EP2	EP1	EP0	
R	R	R/W	R/W	R/W	R/W	R/W	R/W	
0	0	x	x	x	x	x	x	

Bit	Name	Description
5:0	EP[8,6,4,2,1,0]	<p>Endpoint Specific Interrupt Enable.</p> <p>These interrupts occur when the host sends an IN token to a Bulk-IN endpoint which has not been loaded with data and armed for USB transfer. In this case the EZ-USB SIE automatically NAKs the IN token and sets the IBNIRQ bit for the endpoint.</p> <p>Set IE = 1 to enable the interrupt, and IE = 0 to disable it.</p> <p>An IRQ bit is set to '1' to indicate an interrupt request. The interrupt source is available in the interrupt vector register IVEC2. Note The firmware clears an IRQ bit by writing a '1' to it.</p> <p>Note Do not clear an IRQ bit by reading an IRQ register, OR'ing its contents with a bit mask, and writing back the IRQ register. This clears all pending interrupts. Instead, simply write the bit mask value (with a '1' in the bit position of the IRQ you want to clear) directly to the IRQ register.</p>

15.7.5 NAKIE

Endpoint Ping-NAK/IBN Interrupt Enable Register

NAKIE Endpoint Ping-NAK/IBN Interrupt Enable (INT2) E65A							
b7	b6	b5	b4	b3	b2	b1	b0
EP8	EP6	EP4	EP2	EP1	EP0	0	IBN
R/W	R/W	R/W	R/W	R/W	R/W	R/W	R/W
0	0	0	0	0	0	0	0

Bit	Name	Description
Bit 7-2	EP[8,6,4,2,1,0]	<p>Ping-NAK INT Enable.</p> <p>These registers are active only during high-speed (480 Mbps) operation.</p> <p>USB 2.0 improves the USB 1.1 bus bandwidth utilization by implementing a PING-NAK mechanism for OUT transfers. When the host wishes to send OUT data to an endpoint, it first sends a PING token to see if the endpoint is ready, that is, it has an empty buffer. If a buffer is not available, the SIE returns a NAK handshake. PING-NAK transactions continue to occur until an OUT buffer is available, at which time the FX2LP SIE answers a PING with an ACK handshake. Then the host sends the OUT data to the endpoint.</p> <p>The OUT Ping NAK interrupt indicates that the host is trying to send OUT data, but the SIE responded with a NAK because no endpoint buffer memory is available. The firmware may wish to use this interrupt to free up an OUT endpoint buffer.</p>
Bit 0	IBN	<p>IBN INT Enable.</p> <p>This bit is automatically set when any of the IN bulk endpoints responds to an IN token with a NAK. This interrupt occurs when the host sends an IN token to a bulk IN endpoint which has not yet been armed. Individual enables and requests (per endpoint) are controlled by the IBNIE and IBNIRQ registers. Write a '1' to this bit to clear the interrupt request.</p> <p>The IBN INT only fires on a 0-to-1 transition of an 'OR' condition of all IBN sources that are enabled.</p>

15.7.6 NAKIRQ

Endpoint Ping-NAK/IBN Interrupt Request Register

NAKIRQ							Endpoint Ping-NAK/IBN Interrupt Request (INT2)	E65B
b7	b6	b5	b4	b3	b2	b1	b0	
EP8	EP6	EP4	EP2	EP1	EP0	0	IBN	
R/W	R/W	R/W	R/W	R/W	R/W	R	R/W	
x	x	x	x	x	x	0	x	

Bit	Name	Description
7:2	EP[8,6,4,2,1,0]	<p>Ping-NAK INT Request.</p> <p>These registers are active only during high-speed (480 Mbps) operation.</p> <p>USB 2.0 improves the USB 1.1 bus bandwidth utilization by implementing a PING-NAK mechanism for OUT transfers. When the host wishes to send OUT data to an endpoint, it first sends a PING token to see if the endpoint is ready, that is, it has an empty buffer. If a buffer is not available, the SIE returns a NAK handshake. PING-NAK transactions continue to occur until an OUT buffer is available, at which time the FX2LP SIE answers a PING with an ACK handshake. Then the host sends the OUT data to the endpoint.</p> <p>The OUT Ping NAK interrupt indicates that the host is trying to send OUT data, but the SIE responded with a NAK because no endpoint buffer memory is available. The firmware may wish to use this interrupt to free up an OUT endpoint buffer.</p>
0	IBN	<p>IBN INT Request.</p> <p>This bit is automatically set when any of the IN bulk endpoints responds to an IN token with a NAK. This interrupt occurs when the host sends an IN token to a bulk IN endpoint which has not yet been armed. Individual enables and requests (per endpoint) are controlled by the IBNIE and IBNIRQ registers. Write a '1' to this bit to clear the interrupt request.</p> <p>The IBN INT only fires on a 0-to-1 transition of an 'OR' condition of all IBN sources that are enabled.</p> <p>Note The firmware clears an IRQ bit by writing a '1' to it.</p> <p>Note Do not clear an IRQ bit by reading an IRQ register, OR'ing its contents with a bit mask, and writing back the IRQ register. This clears all pending interrupts. Instead, simply write the bit mask value (with a '1' in the bit position of the IRQ you want to clear) directly to the IRQ register.</p>

15.7.7 USBIE

USB Interrupt Enable Register

USBIE		USB Interrupt Enables (INT2)						E65C
b7	b6	b5	b4	b3	b2	b1	b0	
0	EP0ACK	HSGRANT	URES	SUSP	SUTOK	SOF	SUDAV	
R/W	R/W	R/W	R/W	R/W	R/W	R/W	R/W	
0	0	0	0	0	0	0	0	

Bit	Name	Description
6	EP0ACK	EndPoint 0 Acknowledge. Status stage completed.
5	HSGRANT	Grant High-Speed Access. The FX2LP SIE sets this bit when it has been granted high-speed (480 Mbps) access to USB.
4	URES	USB Reset Interrupt Request. The USB signals a bus reset by driving both D+ and D- low for at least 10 milliseconds. When the USB core detects the onset of USB bus reset, it activates the URES interrupt request. The USB core sets this bit to '1' when it detects a USB bus reset. Write a '1' to this bit to clear the interrupt request.
3	SUSP	Suspend Interrupt Request. If the EZ-USB detects 3 ms of no bus activity, it activates the SUSP (Suspend) interrupt request. The USB core sets this bit to '1' when it detects USB SUSPEND signaling (no bus activity for 3 ms). Write a '1' to this bit to clear the interrupt request.
2	SUTOK	Setup Token. The USB core sets this bit to '1' when it receives a SETUP token. Write a '1' to this bit to clear the interrupt request.
1	SOF	Start of Frame. The USB core sets this bit to '1' when it receives a SOF packet. Write a '1' to this bit to clear the interrupt request.
0	SUDAV	SETUP Data Available Interrupt Request. The USB core sets this bit to '1' when it has transferred the eight data bytes from an endpoint zero SETUP packet into internal registers (at SETUPDAT). Write a '1' to this bit to clear the interrupt request. Note Do not clear an IRQ bit by reading an IRQ register, OR'ing its contents with a bit mask, and writing back the IRQ register. This clears all pending interrupts. Instead, simply write the bit mask value (with a '1' in the bit position of the IRQ you want to clear) directly to the IRQ register.

15.7.8 USBIRQ

USB Interrupt Request Register

USBIRQ		USB Interrupt Requests (INT2)						E65D
b7	b6	b5	b4	b3	b2	b1	b0	
0	EP0ACK	HSGRANT	URES	SUSP	SUTOK	SOF	SUDAV	
R	R/W	R/W	R/W	R/W	R/W	R/W	R/W	
0	x	x	x	x	x	x	x	

Bit	Name	Description
6	EP0ACK	EndPoint 0 Acknowledge. Status stage completed.
5	HSGRANT	Grant High-Speed Access. The FX2LP SIE sets this bit when it has been granted high-speed (480 Mbps) access to USB.
4	URES	USB Reset Interrupt Request. The USB signals a bus reset by driving both D+ and D- low for at least 10 milliseconds. When the USB core detects the onset of USB bus reset, it activates the URES interrupt request. The USB core sets this bit to '1' when it detects a USB bus reset. Write a '1' to this bit to clear the interrupt request.
3	SUSP	Suspend Interrupt Request. If the EZ-USB detects 3 ms of no bus activity, it activates the SUSP (Suspend) interrupt request. The USB core sets this bit to '1' when it detects USB SUSPEND signaling (no bus activity for 3 ms). Write a '1' to this bit to clear the interrupt request.
2	SUTOK	Setup Token. The USB core sets this bit to '1' when it receives a SETUP token. Write a '1' to this bit to clear the interrupt request.
1	SOF	Start of Frame. The USB core sets this bit to '1' when it receives a SOF packet. Write a '1' to this bit to clear the interrupt request.
0	SUDAV	SETUP Data Available Interrupt Request. The USB core sets this bit to '1' when it has transferred the eight data bytes from an endpoint zero SETUP packet into internal registers (at SETUPDAT). Write a '1' to this bit to clear the interrupt request. Note Do not clear an IRQ bit by reading an IRQ register, OR'ing its contents with a bit mask, and writing back the IRQ register. This clears all pending interrupts. Instead, simply write the bit mask value (with a '1' in the bit position of the IRQ you want to clear) directly to the IRQ register.

15.7.9 EPIE

Endpoint Interrupt Enable Register

EPIE Endpoint Interrupt Enables (INT2) E65E							
b7	b6	b5	b4	b3	b2	b1	b0
EP8	EP6	EP4	EP2	EP1OUT	EP1IN	EP0OUT	EP0IN
R/W	R/W	R/W	R/W	R/W	R/W	R/W	R/W
0	0	0	0	0	0	0	0

These Endpoint interrupt enable/request registers indicate the pending interrupts for each bulk endpoint. For IN endpoints, the interrupt asserts when the host takes a packet from the endpoint; for OUT endpoints, the interrupt asserts when the host supplies a packet to the endpoint.

The IRQ bits function independently of the Interrupt Enable (IE) bits, so interrupt requests are held whether or not the interrupts are enabled.

Note Do not clear an IRQ bit by reading an IRQ register, OR'ing its contents with a bit mask, and writing back the IRQ register. This clears all pending interrupts. Instead, simply write the bit mask value (with a '1' in the bit position of the IRQ you want to clear) directly to the IRQ register.

15.7.10 EPIRQ

Endpoint Interrupt Request Register

EPIRQ								Endpoint Interrupt Requests (INT2)								E65F	
b7		b6		b5		b4		b3		b2		b1		b0			
EP8		EP6		EP4		EP2		EP1OUT		EP1IN		EP0OUT		EP0IN			
R/W		R/W		R/W		R/W		R/W		R/W		R/W		R/W			
0		0		0		0		0		0		0		0			

These Endpoint interrupt enable/request registers indicate the pending interrupts for each bulk endpoint. For IN endpoints, the interrupt asserts when the host takes a packet from the endpoint; for OUT endpoints, the interrupt asserts when the host supplies a packet to the endpoint.

The IRQ bits function independently of the Interrupt Enable (IE) bits, so interrupt requests are held whether or not the interrupts are enabled.

Note Do not clear an IRQ bit by reading an IRQ register, OR'ing its contents with a bit mask, and writing back the IRQ register. This clears all pending interrupts. Instead, simply write the bit mask value (with a '1' in the bit position of the IRQ you want to clear) directly to the IRQ register.

15.7.11 GPIFIE

GPIF Interrupt Enable Register

GPIFIE see Section 15.15		GPIF Interrupt Enable (INT4)						E660
b7	b6	b5	b4	b3	b2	b1	b0	
0	0	0	0	0	0	GPIFWF	GPIFDONE	
R/W	R/W	R/W	R/W	R/W	R/W	R/W	R/W	
0	0	0	0	0	0	0	0	

Bit	Name	Description
1	GPIFWF	FIFO Read/Write Waveform. GPIF-to-firmware 'hook' in waveform, when waveform descriptor is programmed to assert the GPIFWF interrupt.
0	GPIFDONE	GPIF Idle State. 0 Transaction in progress. 1 Transaction Done (GPIF is idle, hence GPIF is ready for next transaction). Fires IRQ4 if enabled. Note The firmware clears an interrupt request bit by writing a '1' to it. Note Do not clear an IRQ Bit by reading an IRQ register, OR'ing its contents with a bit mask, and writing back the IRQ register. This clears all pending interrupts. Instead, simply write the bit mask value (with a '1' in the bit position of the IRQ you want to clear) directly to the IRQ register.

15.7.12 GPIFIRQ

GPIF Interrupt Request Register

GPIFIRQ see Section 15.15							GPIF Interrupt Request (INT4)		E661
b7	b6	b5	b4	b3	b2	b1	b0		
0	0	0	0	0	0	GPIFWF	GPIFDONE		
R/W	R/W	R/W	R/W	R/W	R/W	R/W	R/W		
0	0	0	0	0	0	x	x		

Bit	Name	Description
1	GPIFWF	FIFO Read/Write Waveform. GPIF-to-firmware 'hook' in waveform, when waveform descriptor is programmed to assert the GPIFWF interrupt.
0	GPIFDONE	GPIF Idle State. 0 Transaction in progress. 1 Transaction Done (GPIF is idle, hence GPIF is ready for next transaction). Fires IRQ4 if enabled.

Note The firmware clears an interrupt request bit by writing a '1' to it.

Note Do not clear an IRQ Bit by reading an IRQ register, OR'ing its contents with a bit mask, and writing back the IRQ register. This clears all pending interrupts. Instead, simply write the bit mask value (with a '1' in the bit position of the IRQ you want to clear) directly to the IRQ register.

15.7.13 USBERRIE

USB Error Interrupt Enable Register

USBERRIE		USB Error Interrupt Enables (INT2)						E662
b7	b6	b5	b4	b3	b2	b1	b0	
ISOEP8	ISOEP6	ISOEP4	ISOEP2	0	0	0	ERRLIMIT	
R/W	R/W	R/W	R/W	R/W	R/W	R/W	R/W	
0	0	0	0	0	0	0	0	

Bit	Name	Description
-----	------	-------------

7:4 **ISOEP[8,6,4,2]** ISO Error Packet.
 The ISO EP Flag is set when ISO OUT data PIDs arrive out of sequence (applies to high speed only) and an ISO OUT packet was dropped because no buffer space was available for an OUT packet (in either full or high-speed modes).

0 **ERRLIMIT** Error Limit.
 ERRLIMIT counts USB bus errors — CRC, bit stuff, and so on, and triggers the interrupt when the programmed limit (0-15) is reached.

The firmware clears an interrupt request bit by writing a '1' to it.

Note Do not clear an IRQ Bit by reading an IRQ register, OR'ing its contents with a bit mask, and writing back the IRQ register. This clears all pending interrupts. Instead, simply write the bit mask value (with a '1' in the bit position of the IRQ you want to clear) directly to the IRQ register.

15.7.14 USBERRIE

USB Error Interrupt Request Register

USBERRIRQ		USB Error Interrupt Request (INT2)					E663
b7	b6	b5	b4	b3	b2	b1	b0
ISOEP8	ISOEP6	ISOEP4	ISOEP2	0	0	0	ERRLIMIT
R/W	R/W	R/W	R/W	R	R	R	R/W
0	0	0	0	0	0	0	x

Bit	Name	Description
7:4	ISOEP[8,6,4,2]	<p>ISO Error Packet.</p> <p>The ISO EP Flag is set when ISO OUT data PIDs arrive out of sequence (applies to high speed only) and an ISO OUT packet was dropped because no buffer space was available for an OUT packet (in either full or high-speed modes).</p>
0	ERRLIMIT	<p>Error Limit.</p> <p>ERRLIMIT counts USB bus errors — CRC, bit stuff, and so on, and triggers the interrupt when the programmed limit (0-15) is reached.</p> <p>The firmware clears an interrupt request bit by writing a '1' to it.</p> <p>Note Do not clear an IRQ Bit by reading an IRQ register, OR'ing its contents with a bit mask, and writing back the IRQ register. This clears all pending interrupts. Instead, simply write the bit mask value (with a '1' in the bit position of the IRQ you want to clear) directly to the IRQ register.</p>

15.7.15 ERRCNTLIM

USB Error Counter Limit Register

ERRCNTLIM		USB Error Counter and Limit						E664
b7	b6	b5	b4	b3	b2	b1	b0	
EC3	EC2	EC1	EC0	LIMIT3	LIMIT2	LIMIT1	LIMIT0	
R	R	R	R	R/W	R/W	R/W	R/W	
x	x	x	x	0	1	0	0	

Bit	Name	Description
7:4	EC[3:0]	USB Error Count. Error count has a maximum value of '15'.
3:0	LIMIT[3:0]	Error Count Limit. USB bus error count and limit. The firmware can enable the interrupt to cause an interrupt when the limit is reached. The default limit count is '4'.

15.7.16 CLRERRCNT

Clear Error Count Register

CLRERRCNT		Clear Error Count EC3:0						E665
b7	b6	b5	b4	b3	b2	b1	b0	
x	x	x	x	x	x	x	x	
W	W	W	W	W	W	W	W	
x	x	x	x	x	x	x	x	

Write any value to this register to clear the EC (Error Count) bits in the ERRCNTLIM register.

15.7.17 INT2IVEC

INT 2 (USB) Autovector Register

INT2IVEC		INTERRUPT 2 (USB) Autovector						E666
b7	b6	b5	b4	b3	b2	b1	b0	
0	I2V4	I2V3	I2V2	I2V1	I2V0	0	0	
R	R	R	R	R	R	R	R	
0	0	0	0	0	0	0	0	

Bit	Name	Description
6:2	I2V[4:0]	<p>INT 2 Autovector.</p> <p>To save the code and processing time required to sort out which USB interrupt occurred, the USB core provides a second level of interrupt vectoring, called Autovectoring. When the CPU takes a USB interrupt, it pushes the program counter onto its stack, and then executes a jump to address 43, where it expects to find a jump instruction to the INT2 service routine.</p> <p>I2V indicates the source of an interrupt from the USB Core. When the USB core generates an INT2 (USB) interrupt request, it updates INT2IVEC to indicate the source of the interrupt. The interrupt sources are encoded on I2V[4:0].</p>

15.7.18 INT4IVEC

INT 4 (slave FIFOs and GPIF) Autovector Register

INT4IVEC		Interrupt 4 (slave FIFOs and GPIF) Autovector						E667
b7	b6	b5	b4	b3	b2	b1	b0	
1	0	I4V3	I4V2	I4V1	I4V0	0	0	
R	R	R	R	R	R	R	R	
1	0	0	0	0	0	0	0	

Bit	Name	Description
5:2	I4V[3:0]	<p>INT 4 Autovector.</p> <p>To save the code and processing time required to sort out which FIFO interrupt occurred, the USB core provides a second level of interrupt vectoring, called Autovectoring. When the CPU takes a USB interrupt, it pushes the program counter onto its stack, and then executes a jump to address 53, where it expects to find a jump instruction to the INT4 service routine.</p> <p>I4V indicates the source of an interrupt from the USB Core. When the USB core generates an INT4 (FIFO/GPIF) interrupt request, it updates INT4IVEC to indicate the source of the interrupt. The interrupt sources are encoded on I4V[3:0].</p>

15.7.19 INTSETUP

INT 2 and INT 4 Setup Register

INTSETUP		INT 2 and INT 4 Setup						E668
b7	b6	b5	b4	b3	b2	b1	b0	
0	0	0	0	AV2EN	0	INT4SRC	AV4EN	
R/W	R/W	R/W	R/W	R/W	R/W	R/W	R/W	
0	0	0	0	0	0	0	0	

Bit	Name	Description
3	AV2EN	INT2 Autovector Enable. To streamline the code that deals with the USB interrupts, this bit enables autovectoring on INT2.
1	INT4SRC	INT 4 Source. 0 INT4 is supplied by the pin (default) 1 INT4 is supplied internally from FIFO/GPIF sources
0	AV4EN	INT4 Autovector Enable. To streamline the 8051 code that deals with the FIFO interrupts, this bit enables autovectoring on INT4.

15.8 Input/Output Registers

15.8.1 PORTACFG

I/O PORTA Alternate Configuration Register

PORTACFG		I/O PORTA Alternate Configuration						E670
b7	b6	b5	b4	b3	b2	b1	b0	
FLAGD	SLCS	0	0	0	0	INT1	INT0	
R/W	R/W	R/W	R/W	R/W	R/W	R/W	R/W	
0	0	0	0	0	0	0	0	

The PORTxCFG register selects alternate functions for the PORTx pins.

Bit	Name	Description
7	FLAGD	FlagD Alternate Configuration. If IFCFG[1:0] = 11, setting this bit to '1' configures the PA7 pin as FLAGD, a programmable FIFO flag.
6	SLCS	$\overline{\text{SLCS}}$ Alternate Configuration. If IFCFG[1:0] = 11, setting this bit to '1' configures the PA7 pin as $\overline{\text{SLCS}}$, the slave FIFO chip select.
1:0	INT[1:0]	Interrupts Enabled for Alternate Configuration. Setting these bits to '1' configures these PORTA pins as the INT1 or INT0 pins.

Note Bits PORTACFG.7 and PORTACFG.6 both affect pin PA7. If both bits are set, FLAGD takes precedence.

Note Bit 3 is the WU2EN bit in the Wakeup register.

15.8.2 PORTCCFG

I/O PORTC Alternate Configuration Register

PORTCCFG		I/O PORTC Alternate Configuration						E671
b7	b6	b5	b4	b3	b2	b1	b0	
GPIFA7	GPIFA6	GPIFA5	GPIFA4	GPIFA3	GPIFA2	GPIFA1	GPIFA0	
R/W	R/W	R/W	R/W	R/W	R/W	R/W	R/W	
0	0	0	0	0	0	0	0	

Bit	Name	Description
7:0	GPIFA[7:0]	Enable GPIF Address Pins. 0 Configure this as Port C. 1 Configure this port to output the lower address of enabled GPIF address pins. Additional bit set in PORTECFG, bit 7.

15.8.3 PORTECFG

I/O PORTE Alternate Configuration Register

PORTECFG		I/O PORTE Alternate Configuration						E672
b7	b6	b5	b4	b3	b2	b1	b0	
GPIFA8	T2EX	INT6	RXD1OUT	RXD0OUT	T2OUT	T1OUT	T0OUT	
R/W	R/W	R/W	R/W	R/W	R/W	R/W	R/W	
0	0	0	0	0	0	0	0	

Bit	Name	Description
7	GPIFA8	Enable GPIF Address Pin. GPIF address bit 8 pin. 0 Configure this as Port E. 1 Configure this port to output the high address of enabled GPIF address pins.
6	T2EX	Timer 2 Counter. Timer/Counter 2 Capture/Reload Input.
5	INT6	INT6 Interrupt Request. 1 Configure this Port E pin as INT6.
4	RXD1OUT	Mode 0: USART1 Synchronous Data Output.
3	RXD0OUT	Mode 0: USART0 Synchronous Data Output.
2:0	T2OUT, T1OUT, T0OUT	Serial Data. Serial mode 0 provides synchronous, half duplex serial communication. For Serial Port 0, serial data output occurs on the RXD0OUT pin, serial data is received on the RXD0 pin, and the TXD0 pin provides the shift clock for both transmit and receive. Mode 0: Clock Output Modes 1-3: Serial Port 0 Data Output.

15.8.4 I2CS

I²C Bus Control and Status Register

I2CS		I ² C Bus Control and Status						E678
b7	b6	b5	b4	b3	b2	b1	b0	
START	STOP	LASTRD	ID1	ID0	BERR	ACK	DONE	
R/W	R/W	R/W	R	R	R	R	R	
0	0	0	x	x	0	0	0	

For additional information refer to “Registers” on page 190 of the Input/Output chapter.

Bit	Name	Description								
7	START	<p>Signal START Condition.</p> <p>1 The next write to I2DAT generates a ‘start’ condition followed by the byte of data written to I2DAT. The START bit is automatically cleared to ‘0’ after the ACK interval.</p>								
6	STOP	<p>Signal STOP Condition.</p> <p>1 After the ACK interval, a ‘stop’ condition is generated. STOP may be set by firmware at any time before, during, or after the 9 bit data transaction. STOP is automatically cleared after the ‘stop’ condition is generated. Data should not be written to I2CS or I2DAT unless the STOP bit is 0.</p> <p>An interrupt request is available to signal that the stop condition is complete; see ‘STOPIE’.</p>								
5	LASTRD	<p>Last Data Read.</p> <p>An I2C master reads data by floating the SDA line and issuing clock pulses on the SCL line. After every eight bits, the master drives SDA low for one clock to indicate ACK. To signal the last byte of a multi-byte transfer, the master <i>floats</i> SDA at ACK time to instruct the slave to stop sending.</p> <p>When LASTRD = 1 at ACK time, the EZ-USB floats the SDA line. The LASTRD bit may be set at any time before or during the data transfer; it is automatically cleared after the ACK interval.</p> <p>Note Setting LASTRD does not automatically generate a ‘stop’ condition. At the end of a read transfer, the STOP bit should also be set.</p>								
4:3	ID[1:0]	<p>Boot EEPROM ID.</p> <p>These bits are set by the boot loader to indicate whether an 8-bit address or 16-bit address EEPROM at slave address 000 or 001 was detected at power-on. Normally, they are used for debug purposes only.</p> <table border="0"> <tr> <td>00</td> <td>No EEPROM found</td> </tr> <tr> <td>01</td> <td>8-bit EEPROM found at slave address 000</td> </tr> <tr> <td>10</td> <td>16-bit EEPROM found at slave address 001</td> </tr> <tr> <td>11</td> <td>Not used</td> </tr> </table>	00	No EEPROM found	01	8-bit EEPROM found at slave address 000	10	16-bit EEPROM found at slave address 001	11	Not used
00	No EEPROM found									
01	8-bit EEPROM found at slave address 000									
10	16-bit EEPROM found at slave address 001									
11	Not used									

(continued on next page)

15.8.4 I2CS (continued)

- 2 BERR** Bus Error.
This bit indicates a bus error. BERR=1 indicates that there was bus contention during the preceding transfer, which results when an outside device drives the bus when it should not, or when another bus master wins arbitration and takes control of the bus.
- When a bus error is detected, the EZ-USB immediately cancels its current transfer, floats the SCL and SDA lines, then sets DONE and BERR. BERR remains set until it is updated at the next ACK interval. The I2C master will not drive SCL till BERR is reset. If the bus error causes the master to detect bus contention and slave to be stuck in the middle of a transfer. Then there is no in-built contention resolution method to workaround this deadlock. If there is a possibility of this condition then the design must implement a method of resetting the slave or clocking the slave till the next ACK.
- DONE is set with BERR only when bus contention occurs during a transfer. If BERR is set and the bus is still busy when firmware attempts to restart a transfer, that second transfer is cancelled but the DONE flag is not set. If contention is expected, EZ-USB firmware should incorporate a timeout to test for this condition. See Steps 1 and 3 of sections [13.5.3 Sending Data](#) and [13.5.4 Receiving Data on page 191](#).
- 1 ACK** Acknowledge Bit.
During the ninth clock of a write transfer, the slave indicates reception of the byte by driving SDA low to acknowledge the byte it just received. The EZ-USB floats SDA during this time, samples the SDA line, and updates the ACK bit with the complement of the detected value: ACK=1 indicates that the slave acknowledged the transfer, and ACK=0 indicates the slave did not. The USB core updates the ACK bit and at the same time it sets DONE=1.
The ACK bit is only meaningful after a write transfer. After a read transfer, its state should be ignored.
- 0 DONE** Transfer DONE.
The EZ-USB sets this bit whenever it completes a byte transfer. The EZ-USB also generates an interrupt request when it sets the DONE bit. The DONE bit is automatically cleared when the I2DAT register is read or written, and the interrupt request bit is automatically cleared by reading or writing the I2CS or I2DAT registers (or by clearing EXIF.5 to 0).

15.8.5 I2CDAT

I²C Bus Data Register

I2DAT		I ² C Bus Data						E679
b7	b6	b5	b4	b3	b2	b1	b0	
D7	D6	D5	D4	D3	D2	D1	D0	
R/W	R/W	R/W	R/W	R/W	R/W	R/W	R/W	
x	x	x	x	x	x	x	x	

For additional information refer to “Registers” on page 190 of the Input/Output chapter.

Bit	Name	Description
7:0	Data	Data Bits. Eight bits of data; writing or reading this register triggers a bus transaction.

15.8.6 I2CTL

I²C Bus Control Register

I2CTL		I ² C Bus Control						E67A
b7	b6	b5	b4	b3	b2	b1	b0	
0	0	0	0	0	0	STOPIE	400KHZ	
R/W	R/W	R/W	R/W	R/W	R/W	R/W	R/W	
0	0	0	0	0	0	0	0	

For additional information refer to “Registers” on page 190 of the Input/Output chapter.

Bit	Name	Description
1	STOPIE	Stop Interrupt Enable Bit. Setting this bit enables the STOP bit interrupt request, which is activated when the STOP bit makes a 1-to-0 transition.
0	400KHZ	High-Speed I2C Bus. For I2C peripherals that support it, the I2C bus can run at 400 kHz. 0 The I2C bus operates at approximately 100 kHz. 1 The I2C bus operates at approximately 400 kHz.

15.8.7 XAUTODATx

AUTOPOINTERS 1 and 2 MOVX Access Registers

XAUTODAT1		AUTOPTR1 MOVX Access						E67B
XAUTODAT2		AUTOPTR2 MOVX Access						E67C
b7	b6	b5	b4	b3	b2	b1	b0	
D7	D6	D5	D4	D3	D2	D1	D0	
R/W	R/W	R/W	R/W	R/W	R/W	R/W	R/W	
x	x	x	x	x	x	x	x	

Bit	Name	Description
7:0	Data	AUTODATx. Data read or written to the XAUTODATx register accesses the memory addressed by the AUTOP RHn/Ln registers, and optionally increments the address after the read or write.

15.9 ECC Control and Data Registers

15.9.1 ECC Features

The EZ-USB can calculate Error Correcting Codes (ECCs) on data that passes across its GPIF or Slave FIFO interfaces. There are two ECC configurations: Two ECCs, each calculated over 256 bytes (SmartMedia Standard); and one ECC calculated over 512 bytes.

The ECC can correct any one-bit error or detect any two-bit error.

Note To use the ECC logic, the GPIF or Slave FIFO interface must be configured for byte-wide operation.

15.9.2 ECC Implementation

The two ECC configurations are selected by the ECCM bit.

ECCM = 0	<p>Two 3-byte ECCs, each calculated over a 256-byte block of data. This configuration conforms to the SmartMedia™ Standard.</p> <p>Write any value to ECCRESET, then pass data across the GPIF or Slave FIFO interface. The ECC for the first 256 bytes of data are calculated and stored in ECC1. The ECC for the next 256 bytes are stored in ECC2. After the second ECC is calculated, the values in the ECCx registers does not change until ECCRESET is written again, even if more data is subsequently passed across the interface.</p>
ECCM = 1	<p>One 3-byte ECC calculated over a 512-byte block of data.</p> <p>Write any value to ECCREST then pass data across the GPIF or Slave FIFO interface. The ECC for the first 512 bytes of data are calculated and stored in ECC1; ECC2 is unused. After the ECC is calculated, the value in ECC1 does not change until ECCRESET is written again, even if more data is subsequently passed across the interface.</p>

15.9.3 ECC Check/Correct

The following code demonstrates the ECC correction algorithms for 256-byte and 512-byte ECCs. In the 256-byte example, the calculated_ecc[] array contains the contents of the appropriate ECCx registers; in the 512-byte example, the ECC1 registers are read directly.

```
//
// ECC Check/Correct for 256-byte ECC.
//
// Enter with 256 bytes of received data in data[], 3 bytes of received ECC in
// received_ecc[], and the ECC calculated by the EZ-USB in calculated_ecc[].
//

UINT8 received_ecc[3];

UINT8 checkECC (void) {
UINT8 a,b,c,x,y;

    a = received_ecc[0] ^ calculated_ecc[0]; // Calculated ecc = received ecc?
    b = received_ecc[1] ^ calculated_ecc[1];
    c = received_ecc[2] ^ calculated_ecc[2];

    if ((a | b | c) == 0) return (ECC_OK); // If so, no error; return.

    if (((a^(a>>1)) & 0x55) == 0x55) && // Does each pair of parity bits contain
        ((b^(b>>1)) & 0x55) == 0x55) && // one error and one match?
        ((c^(c>>1)) & 0x54) == 0x54) {

        x = (a & 0x80); // If so, there's a one-bit error in data[].
        if (a & 0x20) x |= 0x40; // Find which byte is in error...
        if (a & 0x08) x |= 0x20;
        if (a & 0x02) x |= 0x10;
        if (b & 0x80) x |= 0x08;
        if (b & 0x20) x |= 0x04;
        if (b & 0x08) x |= 0x02;
        if (b & 0x02) x |= 0x01;

        y = 0; // ... and which bit...
        if (c & 0x80) y |= 0x04;
        if (c & 0x20) y |= 0x02;
        if (c & 0x08) y |= 0x01;

        data[x] ^= (1 << y); // ... and correct it.

        return (ECC_DATA_FIXED); // Return with one bit fixed.
    }

    y = 0xFF; // If each pair didn't contain one error
    if ((a | b) == 0) y = c; // and one match, check to see if only
    if ((a | c) == 0) y = b; // one bit is in error (which would mean
    if ((b | c) == 0) y = a; // that the received ecc is erroneous).

    if ((y & (y-1)) == 0) { // If so...
        received_ecc[0] = calculated_ecc[0]; // Replace the received ecc with our
        received_ecc[1] = calculated_ecc[1]; // calculated ecc.
        received_ecc[2] = calculated_ecc[2];

        return (ECC_ECC_FIXED); // Return with received ecc fixed.
    }
}
```

```

    return (ECC_ERROR);                // Uncorrectable error in data or received ecc;
                                        // return with data[] and received_ecc[]
                                        // unchanged.
}

-----

//
// ECC Check/Correct for 512-byte ECC.
//
// Enter with 512 bytes of received data in data[], 3 bytes of received ECC in
// received_ecc[].
//
UINT8 received_ecc[3];

UINT8 checkECC (void) {
UINT8 a,b,c,y;
UINT16 x;

    a = received_ecc[0] ^ ecc1B0; // Calculated ecc = received ecc?
    b = received_ecc[1] ^ ecc1B1;
    c = received_ecc[2] ^ ecc1B2;

    if ((a | b | c) == 0) return (ECC_OK); // If so, no error; return.

    if (((a^(a>>1)) & 0x55) == 0x55) && // Does each pair of parity bits contain
        ((b^(b>>1)) & 0x55) == 0x55) && // one error and one match?
        ((c^(c>>1)) & 0x55) == 0x55) {

        x = (a & 0x80);                // If so, there's a one-bit error in data[].
        if (a & 0x20) x |= 0x40; // Find which byte is in error...
        if (a & 0x08) x |= 0x20;
        if (a & 0x02) x |= 0x10;
        if (b & 0x80) x |= 0x08;
        if (b & 0x20) x |= 0x04;
        if (b & 0x08) x |= 0x02;
        if (b & 0x02) x |= 0x01;
        if (c & 0x02) x |= 0x100;

        y = 0;                        // ... and which bit...
        if (c & 0x80) y |= 0x04;
        if (c & 0x20) y |= 0x02;
        if (c & 0x08) y |= 0x01;

        data[x] ^= (1 << y); // ... and correct it.

        return (ECC_DATA_FIXED); // Return with one bit fixed.
    }

    y = 0xFF;                        // If each pair didn't contain one error
    if ((a | b) == 0) y = c; // and one match, check to see if only
    if ((a | c) == 0) y = b; // one bit is in error (which would mean
    if ((b | c) == 0) y = a; // that the received ecc is erroneous).

    if ((y & (y-1)) == 0) { // If so...
        received_ecc[0] = ecc1B0; // Replace the received ecc with our
        received_ecc[1] = ecc1B1; // calculated ecc.
    }
}

```

E67A

```
    received_ecc[2] = ecc1B2;

    return (ECC_ECC_FIXED); // Return with received ecc fixed.
}

return (ECC_ERROR);      // Uncorrectable error in data or received ecc;
                          // return with data[] and received_ecc[]
                          // unchanged.
}
```

15.9.4 ECCCFG

ECC Configuration Register

ECCCFG		ECC Configuration						E628
b7	b6	b5	b4	b3	b2	b1	b0	
0	0	0	0	0	0	0	ECCM	
R	R	R	R	R	R	R	R/W	
0	0	0	0	0	0	0	0	

Bit	Name	Description
Bit 0	ECCM	<p>Select ECC Block Size. ECCM selects the ECC block size mode.</p> <p>0 The ECC logic operates on two blocks of 256 bytes each. 1 The ECC calculator operates on one block of 512 bytes.</p>

15.9.5 ECCRESET

ECC Reset Register

ECCRESET		ECC Reset						E629
b7	b6	b5	b4	b3	b2	b1	b0	
x	x	x	x	x	x	x	x	
W	W	W	W	W	W	W	W	
0	0	0	0	0	0	0	0	

Writing any value to this register resets the ECC logic. After ECCRESET is written, ECC is calculated on the next 512 bytes passed across the GPIF or Slave FIFO interface.

15.9.6 ECC1B0

ECC 1 Byte 0 Register

ECC1B0		ECC 1 Byte 0						E62A
b7	b6	b5	b4	b3	b2	b1	b0	
LINE15	LINE14	LINE13	LINE12	LINE11	LINE10	LINE9	LINE8	
R	R	R	R	R	R	R	R	
0	0	0	0	0	0	0	0	

Bit	Name	Description
7:0	LINE[15:8]	Bits 8-15 of the line parity. See the SmartMedia Specification.

15.9.7 ECC1B1

ECC 1 Byte 1 Register

ECC1B1		ECC 1 Byte 1						E62B
b7	b6	b5	b4	b3	b2	b1	b0	
LINE7	LINE6	LINE5	LINE4	LINE3	LINE2	LINE1	LINE0	
R	R	R	R	R	R	R	R	
0	0	0	0	0	0	0	0	

Bit	Name	Description
7:0	LINE[7:0]	Bits 0-7 of the line parity. See the SmartMedia Specification.

15.9.8 ECC1B2

ECC 1 Byte 2 Register

ECC1B2		ECC 1 Byte 2						E62C
b7	b6	b5	b4	b3	b2	b1	b0	
COL5	COL4	COL3	COL2	COL1	COL0	LINE17	LINE16	
R	R	R	R	R	R	R	R	
0	0	0	0	0	0	0	0	

Bit	Name	Description
7:2	COL[5:0]	6-bit column parity. See the SmartMedia Specification.
1:0	LINE[17:16]	If ECCM = 0, these bits are set to '11' per the SmartMedia Specification. If ECCM = 1, these bits hold bits 16 and 17 of the line parity.

15.9.9 ECC2B0

ECC 2 Byte 0 Register

ECC2B0		ECC 2 Byte 0						E62D
b7	b6	b5	b4	b3	b2	b1	b0	
LINE15	LINE14	LINE13	LINE12	LINE11	LINE10	LINE9	LINE8	
R	R	R	R	R	R	R	R	
0	0	0	0	0	0	0	0	

Bit	Name	Description
7:0	LINE[15:8]	Bits 8-15 of the line parity. See the SmartMedia Specification.

15.9.10 ECC2B1

ECC 2 Byte 1 Register

ECC2B1		ECC 2 Byte 1						E62E
b7	b6	b5	b4	b3	b2	b1	b0	
LINE7	LINE6	LINE5	LINE4	LINE3	LINE2	LINE1	LINE0	
R	R	R	R	R	R	R	R	
0	0	0	0	0	0	0	0	

Bit	Name	Description
7:0	LINE[7:0]	Bits 0-7 of the line parity. See the SmartMedia Specification.

15.9.11 ECC2B2

ECC 2 Byte 2 Register

ECC2B2		ECC 2 Byte 2						E62F
b7	b6	b5	b4	b3	b2	b1	b0	
COL5	COL4	COL3	COL2	COL1	COL0	1	1	
R	R	R	R	R	R	R	R	
0	0	0	0	0	0	0	0	

Bit	Name	Description
7;2	COL[5:0]	This is the 6-bit column parity. See the SmartMedia Specification.

15.10 UDMA CRC Registers

15.10.1 UDMACRCx

UDMA CRC Registers

UDMACRCH **E67D**
 see [Section 15.15](#)

b7	b6	b5	b4	b3	b2	b1	b0
CRC[15:8]							
RW	RW	RW	RW	RW	RW	RW	RW
0	1	0	0	1	0	1	0

UDMACRCL **E67E**
 see [Section 15.15](#)

b7	b6	b5	b4	b3	b2	b1	b0
CRC[7:0]							
RW	RW	RW	RW	RW	RW	RW	RW
1	0	1	1	1	0	1	0

These two registers are strictly for debug purposes. The CRC represented by these registers is calculated based on the rules defined in the ATAPI specification for UDMA transfers. It is calculated automatically by the GPIF as data is transferred on FD[15:0].

These registers return the live calculation of the CRC at any point in the transfer, but are reset to the seed value of 0x4ABA upon the GPIF entering the IDLE state. These registers are writable, therefore, the currently calculated CRC including the seed value can be overwritten at any time.

15.10.2 UDMACRCQUALIFIER

UDMA Qualifier Register

UDMACRCQUALIFIER							E67F
b7	b6	b5	b4	b3	b2	b1	b0
QENABLE	0	0	0	QSTATE	Q SIGNAL[2:0]		
RW	R	R	R	RW	RW	RW	RW
0	0	0	0	0	0	0	0

This register only applies to UDMA IN transactions that are host terminated. Otherwise, this register can be completely ignored.

This register covers a very specific and potentially nonexistent (from a typical system implementation standpoint*) UDMA CRC situation. However rare the situation may be, it is still allowed by the ATAPI specification and thus must be considered and solved by this register.

The ATAPI specification says that if the host (in this case the GPIF) terminates a UDMA IN transaction, that the device (e.g., the disk drive) is allowed to send up to three more words after the host deactivates the HDMARDY signal. These 'dribble' words may not be of interest to the host and thus may be discarded. However, CRC must still be calculated on them since the host and the device must compare and match the CRC at the end of the transaction to consider the transfer error-free.

The GPIF normally only calculates CRC on words that are written into the FIFO (and not discarded). This poses a problem since, in this case, some words are discarded but still must be included in the CRC calculation. This register gives a way to have the GPIF calculate CRC on the extra discarded words as well.

The user would program this register in the following way. The QENABLE bit would be set to '1'. The Q SIGNAL[2:0] field would be programmed to select the CTL pin that coincides with the UDMA STOP signal. The QSTATE bit would be programmed to be '0'. This instructs the GPIF to calculate CRC on any DSTROBE edges from the device when STOP=0, which solves the problem.

Bit	Name	Description
7	QENABLE	This bit enables the CRC qualifier feature, and thus the other bits in this register.
3	QSTATE	This bit determines what state the CRC qualifier signal (selected by Q SIGNAL[2:0] below) must be in to allow CRC to be calculated on words being written into the GPIF.
2:0	Q SIGNAL[2:0]	These bits select which of the CTL[5:0] pins is the CRC qualifier signal.

Note A typical UDMA system has the device, instead of the host, terminate UDMA IN transfers thus completely avoiding this situation.

15.11 USB Control

15.11.1 USBCS

USB Control and Status Register

USBCS		USB Control and Status						E680
b7	b6	b5	b4	b3	b2	b1	b0	
HSM	0	0	0	DISCON	NOSYNSOF	RENUM	SIGRSUME	
R	R	R	R	R/W	R/W	R/W	R/W	
x	0	0	0	0	0	0	0	

Bit	Name	Description
7	HSM	High-Speed Mode. If HSM = 1, the FX2LP SIE is operating in High-Speed Mode, 480 bits/s. Zero-to-one transition of this bit causes a HSGRANT interrupt request.
3	DISCON	Signal a Disconnect on the <u>DISCON</u> Pin. DISCON is one of the EZ-USB control bits in the USBCS (USB Control and Status) register that control the ReNumeration process. Setting this bit to '1' causes a disconnect from the USB bus by removing the internal 1.5K pull up resistor from the D+. A boot EEPROM may be used to default this bit to '1' at startup time. This bit also resets several registers. See the Resets chapter on page 83 for details.
2	NOSYNSOF	Disable Synthesizing Missing SOFs. 1 Disable synthesizing missing SOFs.
1	RENUM	Renumerate. This bit controls whether USB device requests are handled by firmware or automatically by the EZ-USB. When RENUM=0, the USB core handles all device requests. When RENUM=1, the firmware handles all device requests except Set_Address. Set RENUM=1 during a bus disconnect to transfer USB control to the firmware. The EZ-USB automatically sets RENUM=1 under two conditions. <ul style="list-style-type: none"> ■ Completion of a 'C2' boot load ■ When external memory is used (EA=1) and no boot EEPROM is used
0	SIGRSUME	Signal Remote Device Resume. Set SIGRSUME=1 to drive the 'K' state onto the USB bus. This should be done only by a device that is capable of remote wakeup, and then only during the SUSPEND state. To signal RESUME, set SIGRSUME=1, wait 10-15 ms, then set SIGRSUME=0.

15.11.2 SUSPEND

Enter Suspend State Register

SUSPEND		Put Chip into SUSPEND State						E681
b7	b6	b5	b4	b3	b2	b1	b0	
x	x	x	x	x	x	x	x	
W	W	W	W	W	W	W	W	
x	x	x	x	x	x	x	x	

Bit	Name	Description
7:0	Suspend	Enable Suspend Regardless of Bus State. Write any value to this register to prepare the chip for standby without having to wait for a bus suspend.

15.11.3 WAKEUPCS

Wakeup Control and Status Register

WAKEUPCS		Wakeup Control and Status						E682
b7	b6	b5	b4	b3	b2	b1	b0	
WU2	WU	WU2POL	WUPOL	0	DPEN	WU2EN	WUEN	
R/W	R/W	R/W	R/W	R	R/W	R/W	R/W	
x	x	0	0	0	1	0	1	

EZ-USB has two pins that can be activated by external logic to take EZ-USB out of standby. These pins are called WAKEUP and WU2.

Bit	Name	Description
7	WU2	Wakeup Initiated from WU2 Pin. The EZ-USB sets this status bit to '1' when wakeup was initiated by the WU2 pin. Write a '1' to this bit to clear it.
6	WU	Wakeup Initiated from WU Pin. The EZ-USB sets this bit to '1' when wakeup was initiated by the WU pin. Write a '1' to this bit to clear it.
5	WU2POL	Polarity of the WU2 Pin. 0 Active low 1 Active high
4	WUPOL	Polarity of the WU Pin. 0 Active low 1 Active high
2	DPEN	Enable/Disable DPLUS Wakeup. Activity on the USB DPLUS signal normally initiates a USB wakeup sequence. 0 Disable 1 Enable
1	WU2EN	Enable WU2 Wakeup. 1 Enable wakeup from WU2 pin
0	WUEN	Enable WU Wakeup. 1 Enable wakeup from the WAKEUP pin

15.11.4 TOGCTL

Data Toggle Control Register

TOGCTL		Data Toggle Control						E683
b7	b6	b5	b4	b3	b2	b1	b0	
Q	S	R	IO	EP3	EP2	EP1	EP0	
R	R	R	R/W	R/W	R/W	R/W	R/W	
x	0	0	0	0	0	0	0	

Bit	Name	Description
7	Q	Data Toggle Value. 0 Indicates DATA0 and 1 Indicates DATA1, for the endpoint selected by the IO and EP3:0 bits. Write the endpoint select bits (IO and EP3:0), before reading this value.
6	S	Set Data Toggle to DATA1. After selecting the desired endpoint by writing the endpoint select bits (IO and EP3:0), set S=1 to set the data toggle to DATA1. Do not change the endpoint selection bits while this bit is being written.
5	R	Set Data Toggle to DATA0. 1 Set the data toggle to DATA0. Do not change the endpoint selection bits while this bit is being written.
4	IO	Select IN or OUT Endpoint. Set this bit to select an endpoint direction prior to setting its 'R' or 'S' bit. 0 Selects an OUT endpoint 1 Selects an IN endpoint
3:0	EP[3:0]	Select Endpoint. Set these bits to select an endpoint prior to setting its 'R' or 'S' bit. Valid values are 0, 1, 2, 4, 6, and 8.

15.11.5 USBFRAMEH

USB Frame Count High Register

USBFRAMEH		USB Frame Count High						E684
b7	b6	b5	b4	b3	b2	b1	b0	
0	0	0	0	0	FC10	FC9	FC8	
R	R	R	R	R	R	R	R	
0	0	0	0	0	x	x	x	

Bit	Name	Description
2:0	FC[10:8]	High Bits for USB Frame Count. Every millisecond the host sends a SOF token indicating 'Start Of Frame,' along with an 11 bit incrementing frame count. The EZ-USB copies the frame count into these registers at every SOF. One use of the frame count is to respond to the USB SYNC_FRAME Request. If the USB core detects a missing or garbled SOF, it generates an internal SOF and increments USBFRAMEH-USBFRAMEH.

15.11.6 USBFRAMEL

USB Frame Count Low Register

USBFRAMEL		USB Frame Count Low						E685
b7	b6	b5	b4	b3	b2	b1	b0	
FC7	FC6	FC5	FC4	FC3	FC2	FC1	FC0	
R	R	R	R	R	R	R	R	
x	x	x	x	x	x	x	x	

Bit	Name	Description
7:0	FC[7:0]	<p>Low Byte for USB Frame Count.</p> <p>Every millisecond the host sends a SOF token indicating 'Start Of Frame,' along with an 11 bit incrementing frame count. The EZ-USB copies the frame count into these registers at every SOF. One use of the frame count is to respond to the USB SYNC_FRAME Request. If the USB core detects a missing or garbled SOF, it generates an internal SOF and increments USBFRAMEL-USBFRAMEH.</p>

15.11.7 MICROFRAME

USB Microframe Count Register

MICROFRAME		USB Microframe Count, 0-7					E686	
b7	b6	b5	b4	b3	b2	b1	b0	
0	0	0	0	0	MF2	MF1	MF0	
R	R	R	R	R	R	R	R	
0	0	0	0	0	x	x	x	

Bit	Name	Description
2:0	MF[2:0]	Last Occurring Microframe. MICROFRAME contains a count 0-7 which indicates which of the eight 125- μ s microframes last occurred. This register is active only when FX2LP is operating at high speed (480 Mbps).

15.11.8 FNADDR

USB Function Address Register

FNADDR	USB Function Address						E687
b7	b6	b5	b4	b3	b2	b1	b0
0	FA6	FA5	FA4	FA3	FA2	FA1	FA0
R	R	R	R	R	R	R	R
0	x	x	x	x	x	x	x

Bit	Name	Description
6:0	FA[6:0]	<p>USB Function Address.</p> <p>During the USB enumeration process, the host sends a device a unique 7 bit address, which the USB core copies into this register. There is normally no reason for the CPU to know its USB device address because the USB Core automatically responds only to its assigned address.</p>

15.12 Endpoints

15.12.1 EP0BCH

Endpoint 0 (Byte Count High) Register

EP0BCH		Endpoint 0 Byte Count High						E68A
b7	b6	b5	b4	b3	b2	b1	b0	
(BC15)	(BC14)	(BC13)	(BC12)	(BC11)	(BC10)	(BC9)	(BC8)	
R/W	R/W	R/W	R/W	R/W	R/W	R/W	R/W	
x	x	x	x	x	x	x	x	

Bit	Name	Description
7:0	BC[15:8]	<p>High Order Byte Count.</p> <p>Even though the EP0 buffer is only 64 bytes, the EP0 byte count is expanded to 16 bits to allow using the SUDPTR with a custom length, instead of USB-dictated length (from Setup Data Packet and number of requested bytes). The byte count bits in parentheses apply only when SDPAUTO (SUDPTRCTL.0) = 0.</p> <p>The SIE normally determines how many bytes to send over EP0 in response to a device request by taking the smaller of (a) the wLength field in the SETUP packet, and (b) the number of bytes available for transfer (byte count).</p>

15.12.2 EP0BCL

Endpoint 0 Control and Status (Byte Count Low) Register

EP0BCL		Endpoint 0 Byte Count Low						E68B
b7	b6	b5	b4	b3	b2	b1	b0	
(BC7)	BC6	BC5	BC4	BC3	BC2	BC1	BC0	
R/W	R/W	R/W	R/W	R/W	R/W	R/W	R/W	
x	x	x	x	x	x	x	x	

Bit	Name	Description
7:0	BC[7:0]	<p>Low Order Byte Count.</p> <p>Even though the EP0 buffer is only 64 bytes, the EP0 byte count is expanded to 16 bits to allow using the SUDPTR with a custom length, instead of USB-dictated length (from Setup Data Packet and number of requested bytes). The byte count bits in parentheses apply only when SDPAUTO (SUDPTRCTL.0) = 0.</p>

15.12.3 EP1OUTBC

Endpoint 1 OUT Byte Count Register

EP1OUTBC		Endpoint 1 OUT Byte Count						E68D
b7	b6	b5	b4	b3	b2	b1	b0	
0	BC6	BC5	BC4	BC3	BC2	BC1	BC0	
R/W	R/W	R/W	R/W	R/W	R/W	R/W	R/W	
0	x	x	x	x	x	x	x	

Bit	Name	Description
6:0	BC[6:0]	Endpoint 1 OUT Byte Count.

15.12.4 EP1INBC

Endpoint 1 IN Byte Count Register

EP1INBC		Endpoint 1 IN Byte Count						E68F
b7	b6	b5	b4	b3	b2	b1	b0	
0	BC6	BC5	BC4	BC3	BC2	BC1	BC0	
R/W	R/W	R/W	R/W	R/W	R/W	R/W	R/W	
0	x	x	x	x	x	x	x	

Bit	Name	Description
6:0	BC[6:0]	Endpoint 1 IN Byte Count.

15.12.5 EP2BCH

Endpoint 2 Byte Count High Register

EP2BCH		Endpoint 2 Byte Count High						E690
see Section 15.15								
b7	b6	b5	b4	b3	b2	b1	b0	
0	0	0	0	0	BC10	BC9	BC8	
R/W	R/W	R/W	R/W	R/W	R/W	R/W	R/W	
0	0	0	0	0	x	x	x	

Bit	Name	Description
2:0	BC[10:8]	Endpoint 2 Byte Count High. EP2 can be maximum of either 512 or 1024 bytes. These are the high 3 bits of the byte count.

15.12.6 EP6BCH

Endpoint 6 Byte Count High Register

EP6BCH		Endpoint 6 Byte Count High						E698
see Section 15.15								
b7	b6	b5	b4	b3	b2	b1	b0	
0	0	0	0	0	BC10	BC9	BC8	
R/W	R/W	R/W	R/W	R/W	R/W	R/W	R/W	
0	0	0	0	0	x	x	x	

Bit	Name	Description
2:0	BC[10:8]	Endpoint 6 Byte Count High. EP6 can be maximum of either 512 or 1024 bytes. These are the high 3 bits of the byte count.

15.12.7 EP4BCH

Endpoint 4 Byte Count High Register

EP4BCH							Endpoint 4 Byte Count High		E694
see Section 15.15									
b7	b6	b5	b4	b3	b2	b1	b0		
0	0	0	0	0	0	BC9	BC8		
R/W	R/W	R/W	R/W	R/W	R/W	R/W	R/W	R/W	
0	0	0	0	0	0	x	x		

Bit	Name	Description
1:0	BC[9:8]	Endpoint 4 Byte Count High. EP4 can be 512 bytes only. These are the high 2 bits of the byte count.

15.12.8 EP8BCH

Endpoint 8 Byte Count High Register

EP8BCH		Endpoint 8 Byte Count High						E69C
see Section 15.15								
b7	b6	b5	b4	b3	b2	b1	b0	
0	0	0	0	0	0	BC9	BC8	
R/W	R/W	R/W	R/W	R/W	R/W	R/W	R/W	
0	0	0	0	0	0	x	x	

Bit	Name	Description
1:0	BC[9:8]	Endpoint 8 Byte Count High. EP8 can be 512 bytes only. These are the high 2 bits of the byte count.

15.12.9 EPxBCL

Endpoint 2, 4, 6, 8 Byte Count Low Registers

EP2BCL see Section 15.15		Endpoint 2 Byte Count Low						E691
EP4BCL see Section 15.15		Endpoint 4 Byte Count Low						E695
EP6BCL see Section 15.15		Endpoint 6 Byte Count Low						E699
EP8BCL see Section 15.15		Endpoint 8 Byte Count Low						E69D
b7	b6	b5	b4	b3	b2	b1	b0	
BC7/SKIP	BC6	BC5	BC4	BC3	BC2	BC1	BC0	
R/W	R/W	R/W	R/W	R/W	R/W	R/W	R/W	
x	x	x	x	x	x	x	x	

Bit	Name	Description
7:0	BC[7:0]	Byte Count. Low byte count for Endpoints 2, 4, 6, and 8.

15.12.10 EPOCS

Endpoint 0 Control and Status Register

EPOCS		Endpoint 0 Control and Status						E6A0
b7	b6	b5	b4	b3	b2	b1	b0	
HSNAK	0	0	0	0	0	BUSY	STALL	
R/W	R/W	R/W	R/W	R/W	R/W	R	R/W	
1	0	0	0	0	0	0	0	

Bit	Name	Description
7	HSNAK	<p>Hand Shake w/NAK.</p> <p>The STATUS stage consists of an empty data packet with the opposite direction of the data stage, or an IN if there was no data stage. This empty data packet gives the device a chance to ACK, NAK, or STALL the entire CONTROL transfer. Write a '1' to the NAK (handshake NAK) bit to clear it and instruct the USB core to ACK the STATUS stage. The HSNAK bit holds off completing the CONTROL transfer until the device has had time to respond to a request. Clear the HSNAK bit (by writing '1' to it) to instruct the USB core to ACK the status stage of the transfer.</p>
1	BUSY	<p>EP0 Buffer Busy.</p> <p>BUSY is a read only bit that is automatically cleared when a SETUP token arrives. The BUSY bit is set by writing a byte count to EP0BCL.</p>
0	STALL	<p>EP0 Stalled.</p> <p>STALL is a read/write bit that is automatically cleared when a SETUP token arrives. The STALL bit is set by writing a '1' to the register bit.</p> <p>While STALL=1, the USB core sends the STALL PID for any IN or OUT token. This can occur in either the data or handshake phase of the CONTROL transfer.</p> <p>Note To indicate an endpoint stall on endpoint zero, set both the STALL and HSNAK bits. Setting the STALL bit alone causes endpoint zero to NAK forever because the host keeps the control transfer pending.</p>

15.12.11 EP1OUTCS

Endpoint 1 OUT Control and Status Register

EP1OUTCS		Endpoint 1 OUT Control and Status						E6A1
b7	b6	b5	b4	b3	b2	b1	b0	
0	0	0	0	0	0	BUSY	STALL	
R/W	R/W	R/W	R/W	R/W	R/W	R	R/W	
0	0	0	0	0	0	0	0	

Bit	Name	Description
1	BUSY	<p>OUT Endpoint Busy.</p> <p>The BUSY bit indicates the status of the endpoint's OUT Buffer EP1OUTBUF. The USB core sets BUSY=0 when the host data is available in the OUT buffer. The firmware sets BUSY=1 by loading the endpoint's byte count register.</p> <p>When BUSY=1, endpoint RAM data is invalid—the endpoint buffer has been emptied by the firmware and is waiting for new OUT data from the host, or it is the process of being loaded over the USB. BUSY=0 when the USB OUT transfer is complete and endpoint RAM data in EP1OUTBUF is available for the firmware to read. USB OUT tokens for the endpoint are NAK'd while BUSY=1 (the firmware is still reading data from the OUT endpoint).</p> <p>A 1-to-0 transition of BUSY (indicating that the firmware can access the buffer) generates an interrupt request for the OUT endpoint. After the firmware reads the data from the OUT endpoint buffer, it loads the endpoint's byte count register with any value to re-arm the endpoint, which automatically sets BUSY=1. This enables the OUT transfer of data from the host in response to the next OUT token. The CPU should never read endpoint data while BUSY=1.</p>
0	STALL	<p>OUT Endpoint Stalled.</p> <p>Each bulk endpoint (IN or OUT) has a STALL bit in its Control and Status register (bit 0). If the CPU sets this bit, any requests to the endpoint return a STALL handshake rather than ACK or NAK. The Get Status-Endpoint Request returns the STALL state for the endpoint indicated in byte four of the request. Note that bit seven of the endpoint number EP (byte 4) specifies direction.</p>

15.12.12 EP1INCS

Endpoint 1 IN Control and Status Register

EP1INCS		Endpoint 1 IN Control and Status						E6A2
b7	b6	b5	b4	b3	b2	b1	b0	
0	0	0	0	0	0	BUSY	STALL	
R/W	R/W	R/W	R/W	R/W	R/W	R	R/W	
0	0	0	0	0	0	0	0	

Bit	Name	Description
1	BUSY	<p>IN Endpoint Busy.</p> <p>The BUSY bit indicates the status of the endpoint's IN Buffer EP1INBUF. The USB core sets BUSY=0 when the endpoint's IN buffer is empty and ready for loading by the firmware. The firmware sets BUSY=1 by loading the endpoint's byte count register.</p> <p>When BUSY=1, the firmware should not write data to an IN endpoint buffer, because the endpoint FIFO could be in the act of transferring data to the host over the USB. BUSY=0 when the USB IN transfer is complete and endpoint RAM data is available for firmware access. USB IN tokens for the endpoint are NAK'd while BUSY=0 (the firmware is still loading data into the endpoint buffer).</p> <p>A 1-to-0 transition of BUSY (indicating that the firmware can access the buffer) generates an interrupt request for the IN endpoint. After the firmware writes the data to be transferred to the IN endpoint buffer, it loads the endpoint's byte count register with the number of bytes to transfer, which automatically sets BUSY=1. This enables the IN transfer of data to the host in response to the next IN token. Again, the CPU should never load endpoint data while BUSY=1.</p> <p>The firmware writes a '1' to an IN endpoint busy bit to disarm a previously armed endpoint. (This sets BUSY=0.) The firmware should do this only after a USB bus reset, or when the host selects a new interface or alternate setting that uses the endpoint. This prevents stale data from a previous setting from being accepted by the host's first IN transfer that uses the new setting.</p>
0	STALL	<p>IN Endpoint Stalled.</p> <p>Each bulk endpoint (IN or OUT) has a STALL bit in its Control and Status register (bit 0). If the CPU sets this bit, any requests to the endpoint return a STALL handshake rather than ACK or NAK. The Get Status-Endpoint Request returns the STALL state for the endpoint indicated in byte four of the request. Note that bit seven of the endpoint number EP (byte 4) specifies direction.</p>

15.12.13 EP2CS

Endpoint 2 Control and Status Register

EP2CS		Endpoint 2 Control and Status						E6A3
b7	b6	b5	b4	b3	b2	b1	b0	
0	NPAK2	NPAK1	NPAK0	FULL	EMPTY	0	STALL	
R	R	R	R	R	R	R	R/W	
0	0	1	0	1	0	0	0	

Bit	Name	Description
6:4	NPAK[2:0]	Number of Packets in FIFO. The number of packets in the FIFO. 0-4 Packets.
3	FULL	Endpoint FIFO Full. 1 Indicates that the Endpoint FIFO is full.
2	EMPTY	Endpoint FIFO Empty. 1 Indicates that the Endpoint FIFO is empty.
0	STALL	Endpoint STALL. 1 Stall an endpoint 0 Clear a stall When the stall bit is '1,' the USB core returns a STALL handshake for all requests to the endpoint. This notifies the host that something unexpected has happened.

15.12.14 EP4CS

Endpoint 4 Control and Status Register

EP4CS		Endpoint 4 Control and Status						E6A4
b7	b6	b5	b4	b3	b2	b1	b0	
0	0	NPAK1	NPAK0	FULL	EMPTY	0	STALL	
R	R	R	R	R	R	R	R/W	
0	0	1	0	1	0	0	0	

Bit	Name	Description
5:4	NPAK[1:0]	Number of Packets in FIFO. The number of packets in the FIFO. 0-2 Packets.
3	FULL	Endpoint FIFO Full. 1 Indicates that the Endpoint FIFO is full.
2	EMPTY	Endpoint FIFO Empty. 1 Indicates that the Endpoint FIFO is empty.
0	STALL	Endpoint STALL. 1 Stall an endpoint 0 Clear a stall When the stall bit is '1,' the USB core returns a STALL handshake for all requests to the endpoint. This notifies the host that something unexpected has happened.

15.12.15 EP6CS

Endpoint 6 Control and Status Register

EP6CS		Endpoint 6 Control and Status						E6A5
b7	b6	b5	b4	b3	b2	b1	b0	
0	NPAK2	NPAK1	NPAK0	FULL	EMPTY	0	STALL	
R	R	R	R	R	R	R	R/W	
0	0	0	0	0	1	0	0	

Bit	Name	Description
6:4	NPAK[2:0]	Number of Packets in FIFO. The number of packets in the FIFO. 0-4 Packets.
3	FULL	Endpoint FIFO Full. 1 Indicates that the Endpoint FIFO is full.
2	EMPTY	Endpoint FIFO Empty. 1 Indicates that the Endpoint FIFO is empty.
0	STALL	Endpoint STALL. 1 Stall an endpoint 0 Clear a stall When the stall bit is '1,' the USB core returns a STALL handshake for all requests to the endpoint. This notifies the host that something unexpected has happened.

15.12.16 EP8CS

Endpoint 8 Control and Status Register

EP8CS		Endpoint 8 Control and Status						E6A6
b7	b6	b5	b4	b3	b2	b1	b0	
0	0	NPAK1	NPAK0	FULL	EMPTY	0	STALL	
R	R	R	R	R	R	R	R/W	
0	0	0	0	0	1	0	0	

Bit	Name	Description
5:4	NPAK[1:0]	Number of Packets in FIFO. The number of packets in the FIFO. 0-2 Packets.
3	FULL	Endpoint FIFO Full. 1 Indicates that the Endpoint FIFO is full.
2	EMPTY	Endpoint FIFO Empty. 1 Indicates that the Endpoint FIFO is empty.
0	STALL	Endpoint STALL. 1 Stall an endpoint 0 Clear a stall When the stall bit is '1,' the USB core returns a STALL handshake for all requests to the endpoint. This notifies the host that something unexpected has happened.

15.12.17 EP2FIFOFLGS

Endpoint 2 Slave FIFO Flags Register

EP2FIFOFLGS		Endpoint 2 Slave FIFO Flags					E6A7	
b7	b6	b5	b4	b3	b2	b1	b0	
0	0	0	0	0	PF	EF	FF	
R	R	R	R	R	R	R	R	
0	0	0	0	0	0	1	0	

Bit	Name	Description
2	PF	Programmable Flag. State of the EP2 Programmable Flag.
1	EF	Empty Flag. State of the EP2 Empty Flag.
0	FF	Full Flag. State of the EP2 Full Flag. Note FIFOPINPOLAR settings do not affect the behavior of these bits.

15.12.18 EP4FIFOFLGS

Endpoint 4 Slave FIFO Flags Register

EP4FIFOFLGS		Endpoint 4 Slave FIFO Flags					E6A8	
b7	b6	b5	b4	b3	b2	b1	b0	
0	0	0	0	0	PF	EF	FF	
R	R	R	R	R	R	R	R	
0	0	0	0	0	0	1	0	

Bit	Name	Description
2	PF	Programmable Flag. State of the EP4 Programmable Flag.
1	EF	Empty Flag. State of the EP4 Empty Flag.
0	FF	Full Flag. State of the EP4 Full Flag. Note FIFOPINPOLAR settings do not affect the behavior of these bits.

15.12.19 EP6FIFOFLGS

Endpoint 6 Slave FIFO Flags Register

EP6FIFOFLGS		Endpoint 6 Slave FIFO Flags						E6A9
b7	b6	b5	b4	b3	b2	b1	b0	
0	0	0	0	0	PF	EF	FF	
R	R	R	R	R	R	R	R	
0	0	0	0	0	1	1	0	

Bit	Name	Description
2	PF	Programmable Flag. State of the EP6 Programmable Flag. Note The default value is different from EP2FIFOFLGS.PF and EP4FIFOFLGS.PF.
1	EF	Empty Flag. State of the EP6 Empty Flag.
0	FF	Full Flag. State of the EP6 Full Flag. Note FIFOPINPOLAR settings do not affect the behavior of these bits.

15.12.20 EP8FIFOFLGS

Endpoint 8 Slave FIFO Flags Register

EP8FIFOFLGS		Endpoint 8 Slave FIFO Flags					E6AA	
b7	b6	b5	b4	b3	b2	b1	b0	
0	0	0	0	0	PF	EF	FF	
R	R	R	R	R	R	R	R	
0	0	0	0	0	1	1	0	

Bit	Name	Description
2	PF	Programmable Flag. State of the EP8 Programmable Flag. Note The default value is different from EP2FIFOFLGS.PF and EP4FIFOFLGS.PF.
1	EF	Empty Flag. State of the EP8 Empty Flag.
0	FF	Full Flag. State of the EP8 Full Flag. Note FIFOPINPOLAR settings do not affect the behavior of these bits.

15.12.21 EP2FIFOBCH

Endpoint 2 Slave FIFO Total Byte Count High Register

EP2FIFOBCH		Endpoint 2 Slave FIFO Total Byte Count High						E6AB
b7	b6	b5	b4	b3	b2	b1	b0	
0	0	0	BC12	BC11	BC10	BC9	BC8	
R	R	R	R	R	R	R	R	
0	0	0	0	0	0	0	0	

Bit	Name	Description
4:0	BC[12:8]	Byte Count High Total number of bytes in Endpoint FIFO. Maximum of 4096 bytes.

15.12.22 EP6FIFOBCH

Endpoint 6 Slave FIFO Total Byte Count High Register

EP6FIFOBCH		Endpoint 6 Slave FIFO Total Byte Count High						E6AF
b7	b6	b5	b4	b3	b2	b1	b0	
0	0	0	0	BC11	BC10	BC9	BC8	
R	R	R	R	R	R	R	R	
0	0	0	0	0	0	0	0	

Bit	Name	Description
3:0	BC[11:8]	Byte Count High. Total number of bytes in Endpoint FIFO. Maximum of 2048 bytes.

15.12.23 EP4FIFOBCH

Endpoint 4 Slave FIFO Total Byte Count High Register

EP4FIFOBCH		Endpoint 4 Slave FIFO Total Byte Count High						E6AD
b7	b6	b5	b4	b3	b2	b1	b0	
0	0	0	0	0	BC10	BC9	BC8	
R	R	R	R	R	R	R	R	
0	0	0	0	0	0	0	0	

Bit	Name	Description
2:0	BC[10:8]	Byte Count High. Total number of bytes in Endpoint FIFO. Maximum of 1024 bytes.

15.12.24 EP8FIFOBCH

Endpoint 8 Slave FIFO Total Byte Count High Register

EP8FIFOBCH		Endpoint 8 Slave FIFO Total Byte Count High						E6B1
b7	b6	b5	b4	b3	b2	b1	b0	
0	0	0	0	0	BC10	BC9	BC8	
R	R	R	R	R	R	R	R	
0	0	0	0	0	0	0	0	

Bit	Name	Description
2:0	BC[10:8]	Byte Count High. Total number of bytes in Endpoint FIFO. Maximum of 1024 bytes.

15.12.25 EPxFIFOBCL

Endpoint 2, 4, 6, 8 Slave FIFO Byte Count Low Registers

EP2FIFOBCL		Endpoint 2 Slave FIFO Total Byte Count Low						E6AC
EP4FIFOBCL		Endpoint 4 Slave FIFO Total Byte Count Low						E6AE
EP6FIFOBCL		Endpoint 6 Slave FIFO Total Byte Count Low						E6B0
EP8FIFOBCL		Endpoint 8 Slave FIFO Total Byte Count Low						E6B2
b7	b6	b5	b4	b3	b2	b1	b0	
BC7	BC6	BC5	BC4	BC3	BC2	BC1	BC0	
R	R	R	R	R	R	R	R	
0	0	0	0	0	0	0	0	

Bit	Name	Description
7:0	BC[7:0]	Byte Count High. Low byte for number of bytes in Endpoint FIFO.

15.12.26 SUDPTRx

Setup Data Pointer High and Low Address Registers

SUDPTRH Setup Data Pointer High Address Byte E6B3							
b7	b6	b5	b4	b3	b2	b1	b0
A15	A14	A13	A12	A11	A10	A9	A8
R/W	R/W	R/W	R/W	R/W	R/W	R/W	R/W
x	x	x	x	x	x	x	x

SUDPTRL Setup Data Pointer Low Address Byte E6B4							
b7	b6	b5	b4	b3	b2	b1	b0
A7	A6	A5	A4	A3	A2	A1	A0
R/W	R/W	R/W	R/W	R/W	R/W	R/W	R
x	x	x	x	x	x	x	0

Bit	Name	Description
15:0	A[15:0]	<p>Setup Data Pointer. This buffer is used as a target or source by the Setup Data Pointer and it must be WORD (2-byte) aligned. This 16-bit pointer, SUDPTRH:L provides hardware assistance for handling CONTROL IN transfers.</p> <p>When the firmware loads SUDPTRL, the SIE automatically responds to IN commands with the appropriate data. If SDPAUTO=1, the length field is taken from the packet or descriptor. If SDPAUTO=0, SUDPTRL triggers a send to the host and the length is taken from the EP0BCH and EP0BCL bytes.</p>

15.12.27 SUDPTRCTL

Setup Data Pointer Auto Register

SUDPTRCTL							Setup Data Pointer AUTO Mode	E6B5
b7	b6	b5	b4	b3	b2	b1	b0	
0	0	0	0	0	0	0	SDPAUTO	
R/W	R/W	R/W	R/W	R/W	R/W	R/W	R/W	
0	0	0	0	0	0	0	1	

Bit	Name	Description
-----	------	-------------

0	SDPAUTO	<p>Setup Data Pointer Auto Mode.</p> <p>To send a block of data using the Setup Data Pointer, the block's starting address is loaded into SUDPTRH:L. The block length must previously have been set; the method for accomplishing this depends on the state of the SDPAUTO bit.</p> <p>0 Manual Mode. Used for general purpose block transfers. Firmware writes the block length to EP0BCH:L.</p> <p>1 Auto Mode. Used for sending Device, Configuration, String, Device Qualifier, and Other Speed Configuration descriptors only. The block length is automatically read from the length field of the descriptor itself; no explicit loading of EP0BCH:L is necessary.</p>
---	----------------	------------------------------------------------------------------------------------------------------------------------------------------------------------------------------------------------------------------------------------------------------------------------------------------------------------------------------------------------------------------------------------------------------------------------------------------------------------------------------------------------------------------------------------------------------------------------------------------------------------------------------------------------------------------------------

Writing to SUDPTRL starts the transfer; the EZ-USB automatically sends the entire block, packetizing as necessary.

Note When SDPAUTO = 0, writing to EP0BCH:L only sets the block length; it does not arm the transfer (the transfer is armed by writing to SUDPTRL). Therefore, before performing an EP0 transfer which does not use the Setup Data Pointer (such as, one which is meant to be armed by writing to EP0BCL), SDPAUTO must be set to '1'.

15.12.28 SETUPDAT

Setup Data - Eight Bytes Registers

SETUPDAT		8 Bytes of Setup Data						E6B8-E6BF
b7	b6	b5	b4	b3	b2	b1	b0	
D7	D6	D5	D4	D3	D2	D1	D0	
R	R	R	R	R	R	R	R	
x	x	x	x	x	x	x	x	

The setup data bytes are defined as follows:

SETUPDAT[0] = bmRequestType
 SETUPDAT[1] = bmRequest
 SETUPDAT[2:3] = wValue
 SETUPDAT[4:5] = wIndex
 SETUPDAT[6:7] = wLength

This buffer contains the eight bytes of SETUP packet data from the most recently received CONTROL transfer.

The data in SETUPBUF is valid when the SUDAV (Setup Data Available) interrupt request bit is set.

15.13 General Programmable Interface

15.13.1 GPIFWFSELECT

GPIF Waveform Selector Register

GPIFWFSELECT		Waveform Selector						E6C0
b7	b6	b5	b4	b3	b2	b1	b0	
SINGLEWR1	SINGLEWR0	SINGLERD1	SINGLERD0	FIFOWR1	FIFOWR0	FIFORD1	FIFORD0	
R/W	R/W	R/W	R/W	R/W	R/W	R/W	R/W	
1	1	1	0	0	1	0	0	

Bit	Name	Description
7:6	SINGLEWR[1:0]	Single Write Waveform Index. Index to the Waveform program to run when a 'Single Write' is triggered by the firmware.
5:4	SINGLERD[1:0]	Single Read Waveform Index. Index to the Waveform program to run when a 'Single Read' is triggered by the firmware.
3:2	FIFOWR[1:0]	FIFO Write Waveform Index. Index to the Waveform program to run when a 'FIFO Write' is triggered by the firmware.
1:0	FIFORD[1:0]	FIFO Read Waveform Index. Index to the Waveform program to run when a 'FIFO Read' is triggered by the firmware. Select waveform 0 [00], 1 [01], 2 [10] or 3 [11].

15.13.2 GPIFIDLECS

GPIF Done and Idle Drive Mode Register

GPIFIDLECS		GPIF Done, GPIF Idle Drive Mode						E6C1
b7	b6	b5	b4	b3	b2	b1	b0	
DONE	0	0	0	0	0	0	IDLEDRV	
R/W	R/W	R/W	R/W	R/W	R/W	R/W	R/W	
1	0	0	0	0	0	0	0	

Bit	Name	Description
7	DONE	GPIF Idle State. 0 Transaction in progress. 1 Transaction Done (GPIF is idle, hence GPIF is ready for next transaction). Fires IRQ4 if enabled.
0	IDLEDRV	Set Data Bus when GPIF Idle. When the GPIF is idle: 0 Tri-state the Data Bus. 1 Drive the Data Bus.

15.13.3 GPIFIDLECTL

CTL Output in Idle Register

GPIFIDLECTL		CTL Output States in Idle						E6C2
b7	b6	b5	b4	b3	b2	b1	b0	
0/CTLOE3	0/CTLOE2	CTL5/ CTLOE1	CTL4/ CTLOE0	CTL3	CTL2	CTL1	CTL0	
R/W	R/W	R/W	R/W	R/W	R/W	R/W	R/W	
1	1	1	1	1	1	1	1	

Bit	Name	Description
7:4	CTLOE[3:0]	CTL Output Enables.
5:0	CTL[5:0]	CTL Output States. See GPIFCTLCFG register on page 336 .

15.13.4 GPIFCTLCFG

CTL Output Drive Type Register

GPIFCTLCFG		CTL Output Drive Type					E6C3
b7	b6	b5	b4	b3	b2	b1	b0
TRICTL	0	CTL5	CTL4	CTL3	CTL2	CTL1	CTL0
R/W	R/W	R/W	R/W	R/W	R/W	R/W	R/W
0	0	0	0	0	0	0	0

Bit	Name	Description
-----	------	-------------

- 7 **TRICTL** Number Active Outputs/Tri-stating.
- 5:0 **CTL[5:0]** CTL Output Drive Type
 The GPIF Control pins (CTL[5:0]) have several output modes:
 - CTL[3:0] can act as CMOS outputs (optionally tri-statable) or open-drain outputs.
 - CTL[5:4] can act as CMOS outputs or open-drain outputs. If CTL[3:0] are configured to be tri-statable, CTL[5:4] are not available.

TRICTL (GPIFCTLCFG.7)	GPIFCTLCFG[5:0]	CTL[3:0]	CTL[5:4]
0	0	CMOS, Not Tri-statable	CMOS, Not Tri-statable
0	1	Open-Drain	Open-Drain
1	X	CMOS, Tri-statable	Not Available

During the IDLE State, the state of CTL[5:0] depends on register bits:

- TRICTL (GPIFCTLCFG.7)
- GPIFCTLCFG[5:0]
- GPIFIDLECTL[5:0]

The combination of these bits defines CTL5:0 during IDLE as follows:

- If TRICTL is 0, GPIFIDLECTL[5:0] directly represent the output states of CTL5:0 during the IDLE State. The GPIFCTLCFG[5:0] bits determine whether the CTL5:0 outputs are CMOS or open-drain: If GPIFCTLCFG.x = 0, CTLx is CMOS; if GPIFCTLCFG.x = 1, CTLx is open drain.
- If TRICTL is 1, GPIFIDLECTL[7:4] are the output enables for the CTL[3:0] signals, and GPIFIDLECTL[3:0] are the output values for CTL[3:0]. CTL4 and CTL5 are unavailable in this mode.

(continued on next page)

15.13.4 GPIFCTLCFG (continued)

TRICTL	Control Output	Output State	Output Enable
0	CTL0	GPIFIDLECTL.0	N/A (CTL Outputs are always enabled when TRICTL = 0)
	CTL1	GPIFIDLECTL.1	
	CTL2	GPIFIDLECTL.2	
	CTL3	GPIFIDLECTL.3	
	CTL4	GPIFIDLECTL.4	
	CTL5	GPIFIDLECTL.5	
1	CTL0	GPIFIDLECTL.0	GPIFIDLECTL.4
	CTL1	GPIFIDLECTL.1	GPIFIDLECTL.5
	CTL2	GPIFIDLECTL.2	GPIFIDLECTL.6
	CTL3	GPIFIDLECTL.3	GPIFIDLECTL.7
	CTL4	N/A (CTL4 and CTL5 are not available when TRICTL = 1)	
	CTL5		

15.13.5 GPIFADRH

GPIF Address High Register

GPIFADRH see Section 15.15		GPIF Address High						E6C4
b7	b6	b5	b4	b3	b2	b1	b0	
0	0	0	0	0	0	0	GPIFA8	
R/W	R/W	R/W	R/W	R/W	R/W	R/W	R/W	
0	0	0	0	0	0	0	0	

Bit	Name	Description
0	GPIFA8	High Bit of GPIF Address. See GPIFADRL register on page 339 .

15.13.6 GPIFADRL

GPIF Address Low Register

GPIFADRL see Section 15.15		GPIF Address Low						E6C5
b7	b6	b5	b4	b3	b2	b1	b0	
GPIFA7	GPIFA6	GPIFA5	GPIFA4	GPIFA3	GPIFA2	GPIFA1	GPIFA0	
R/W	R/W	R/W	R/W	R/W	R/W	R/W	R/W	
0	0	0	0	0	0	0	0	

Bit	Name	Description
7:0	GPIFA[7:0]	Lower eight bits of GPIF Address. Data written to this register immediately appears as the bus address on the ADR[7:0] pins.

15.13.7 FLOWSTATE

GPIF Flow State Register

FLOWSTATE							E6C6
b7	b6	b5	b4	b3	b2	b1	b0
FSE	0	0	0	0	FS[2:0]		
RW	R	R	R	R	RW	RW	RW
0	0	0	0	0	0	0	0

Any one (and only one) of the seven GPIF states in a waveform can be programmed to be the flow state. This register defines which state, if any, in the next invoked GPIF waveform will be the flow state.

Bit	Name	Description
7	FSE	Global Flow State Enable. Global enable for the flow state. When it is disabled all flow state registers are don't care and the next waveform invocation does not cause a flow state to be used.
2:0	FS[2:0]	Flow State Selection. Defines which GPIF state is the flow state. Valid values are 0-6.

15.13.8 FLOWLOGIC

GPIF Flow State Logic Register

FLOWLOGIC							E6C7
b7	b6	b5	b4	b3	b2	b1	b0
LFUNC[1:0]		TERMA[2:0]			TERMB[2:0]		
RW	RW	RW	RW	RW	RW	RW	RW
0	0	0	0	0	0	0	0

The bit definitions for this register are analogous to the bit definitions in the RDY LOGIC opcode in a waveform descriptor. Except, instead of controlling the branching for a decision point, it controls the freezing or flowing of data on the bus in a flow state.

The user defines the states of CTL[5:0] for when the flow logic equals '0' and '1' (see FLOWEQ0_CTL and FLOWEQ1_CTL). This is useful in activating or deactivating protocol ready signals to hold off an external master (where the GPIF is acting like a slave) in response to internal FIFO flags warning of an impending underflow or overflow situation.

In the case where the GPIF is the master, the user also defines whether Master strobe (a CTL pin in this case; see FLOW-STB) toggles (reads or writes data on the bus) when the flow logic evaluates to a '1' or a '0'. This is useful for the GPIF to consider protocol ready signals from the slave as well as FIFO flags to decide when to clock data out of or into the FIFOs and when to freeze the data flow instead.

It should be noted that this flow logic does not replace the decision point logic defined in a waveform descriptor. The decision point logic in a waveform descriptor is still used to decide when to branch out of the flow state. The decision point logic can use an entirely different pair of ready signals than the flow logic in making its decisions.

Bit	Name	Description
7:6	LFUNC[1:0]	Flow State Logic Function. 00 A AND B 01 A OR B 10 A XOR B 11 !A AND B Since the flow logic decision can be based on the output being a '1' or a '0', NAND, NOR, XNOR and !(A AND B) operations can be achieved as well. Note that !(A AND B) is the same as (A OR !B).
5:3	TERMA[2:0]	Flow State Logic Function Arguments.
2:0	TERMB[2:0]	0 RDY[0] 1 RDY[1] 2 RDY[2] 3 RDY[3] 4 RDY[4] 5 RDY[5] or TC-Expiration (depending on GPIF_READYCFG.5) 6 FIFO Flag (PF, EF, or FF depending on GPIF_EPxFLGSEL) 7 8051 RDY (GPIF_READYCFG.7)

15.13.9 FLOWEQxCTL

GPIF Flow Logic CTL Output Drive Registers

FLOWEQ0CTL							E6C8
b7	b6	b5	b4	b3	b2	b1	b0
CTLOE3	CTLOE2	CTLOE1/ CTL5	CTLOE0/ CTL4	CTL3	CTL2	CTL1	CTL0
RW	RW	RW	RW	RW	RW	RW	RW
0	0	0	0	0	0	0	0

FLOWEQ1CTL							E6C9
b7	b6	b5	b4	b3	b2	b1	b0
CTLOE3	CTLOE2	CTLOE1/ CTL5	CTLOE0/ CTL4	CTL3	CTL2	CTL1	CTL0
RW	RW	RW	RW	RW	RW	RW	RW
0	0	0	0	0	0	0	0

FLOWEQ0CTL defines the state of the CTL5:0 pins when the output of the flow logic equals zero; FLOWEQ1CTL defines the state when the logic output equals one. During a flow state, the CTL opcode in the waveform descriptor is completely ignored and the behavior of the CTL[5:0] pins are defined by these two registers instead.

Bit	Name	Description
CTLOEx		<p>If TRICTL = 1, CTL5:4 are unused and CTLOE3:0 specifies whether the corresponding CTL3:0 output signals are tri-stated.</p> <p>0 Tri-state CTLx</p> <p>1 Drive CTLx</p>
CTLx		<p>Specifies the state to set each CTLx signal to during this entire State.</p> <p>1 High level</p> <p>If the CTLx bit in the GPIFCTLCFG register is set to '1', the output driver is an open drain.</p> <p>If the CTLx bit in the GPIFCTLCFG register is set to '0', the output driver is driven to CMOS levels.</p> <p>0 Low level</p> <p>Defined by FLOWEQxCTL and these bits, instead:</p> <p>TRICTL (GPIFCTLCFG.7), as described in section 10.2.3.1 Control Output Modes on page 124. GPIFCTLCFG[5:0].</p> <p>The combination of these bits defines CTL5:0 during a Flow State as follows:</p> <ul style="list-style-type: none"> ■ If TRICTL is '0', FLOWEQxCTL[5:0] directly represent the output states of CTL5:0 during the Flow State. The GPIFCTLCFG[5:0] bits determine whether the CTL5:0 outputs are CMOS or open drain: If GPIFCTLCFG.x = 0, CTLx is CMOS; if GPIFCTLCFG.x = 1, CTLx is open drain. ■ If TRICTL is '1', FLOWEQxCTL[7:4] are the output enables for the CTL[3:0] signals, and FLOWEQxCTL[3:0] are the output values for CTL[3:0]. CTL4 and CTL5 are unavailable in this mode.

(continued on next page)

15.13.9 FLOWEQxCTL (continued)

TRICTL	Control Output	Output State	Drive Type (0 = CMOS, 1 = Open-Drain)	Output Enable	
0	CTL0	FLOWEQxCTL.0	GPIFCTLCFG.0	N/A (CTL Outputs are always enabled when TRICTL = 0)	
	CTL1	FLOWEQxCTL.1	GPIFCTLCFG.0		
	CTL2	FLOWEQxCTL.2	GPIFCTLCFG.0		
	CTL3	FLOWEQxCTL.3	GPIFCTLCFG.0		
	CTL4	FLOWEQxCTL.4	GPIFCTLCFG.0		
	CTL5	FLOWEQxCTL.5	GPIFCTLCFG.0		
1	CTL0	FLOWEQxCTL.0	N/A (CTL Outputs are always tri-statable CMOS when TRICTL = 1)	FLOWEQxCTL.4	
	CTL1	FLOWEQxCTL.1		FLOWEQxCTL.5	
	CTL2	FLOWEQxCTL.2		FLOWEQxCTL.6	
	CTL3	FLOWEQxCTL.3		FLOWEQxCTL.7	
	CTL4	N/A			
	CTL5	(CTL4 and CTL5 are not available when TRICTL = 1)			

15.13.10 FLOWSTB

GPIF Flow Master Strobe Register

FLOWSTB							E6CB
b7	b6	b5	b4	b3	b2	b1	b0
SLAVE	RDYASYNC	CTLTOGL	SUSTAIN	0	MSTB[2:0]		
RW	RW	RW	RW	R	RW	RW	RW
0	0	1	0	0	0	0	0

Based on suggested FLOW_LOGIC settings.

This register defines the Master strobe that causes data to be read or written during a flow state.

For transactions where GPIF is the slave on the bus, the Master strobe is one of the RDY[5:0] pins. This includes external masters that can either write data into GPIF (for example, UDMA IN) or read data out of GPIF.

For transactions where GPIF is the master on the bus, the Master strobe is one of the CTL[5:0] pins. This includes cases where the GPIF writes data out to a slave (for example, UDMA OUT) or reads data from a slave.

Bit	Name	Description
7	SLAVE	<p>0 GPIF is the master of the bus transaction. This means that one of the CTL[5:0] pins is the Master strobe and the particular one is selected by MSTB[2:0].</p> <p>1 GPIF is the slave of the bus transaction. This means that one of the RDY[5:0] pins is the Master strobe and the particular one is selected by MSTB[2:0].</p>
6	RDYASYNC	<p>If SLAVE is '0' then this bit is ignored, otherwise:</p> <p>0 Master strobe (which is a RDY pin in this case) is synchronous to IFCLK.</p> <p>1 Master strobe (which is a RDY pin in this case) is asynchronous to IFCLK.</p>
5	CTLTOGL	<p>If SLAVE is '1' then this bit is ignored. Otherwise, this bit defines which state of the flow logic (see FLOWLOGIC) causes Master strobe (which is a CTL pin in this case) to toggle. For example, if this bit is set to '1', then if the output of the flow logic equals '1' then Master strobe toggles causing data to flow on the bus. If in the same example the output of the flow logic equals '0' then Master strobe freezes causing data flow to halt on the bus.</p>
4	SUSTAIN	<p>If SLAVE is '1' then this bit is ignored. Upon exiting a flow state in which SLAVE is '0', Master strobe (which is a CTL pin in this case) normally goes back to adhering to the CTL opcodes defined in the waveform descriptor.</p>
2:0	MSTB[2:0]	<p>If SLAVE is '0' then these bits select which CTL[5:0] pin is the Master strobe. If SLAVE is '1' then these bits select which RDY[5:0] pin is the Master strobe.</p>

15.13.11 FLOWHOLDOFF

GPIF Flow Holdoff Register

FLOWHOLDOFF							E6CA
b7	b6	b5	b4	b3	b2	b1	b0
HOPERIOD[3:0]				HOSTATE	HOCTL[2:0]		
RW	RW	RW	RW	RW	RW	RW	RW
0	0	0	1	0	0	1	0

For flow state transactions that meet the following criteria:

1. The interface is asynchronous.
1. GPIF is acting like a slave (FLOWSTB.SLAVE = 1), and thus Master strobe is a RDY pin.
2. Data is being written into the GPIF.
3. The rate at which data is being written in exceeds 96 MB/s for a word wide data bus or 48 MB/s for a byte wide data bus.

Bit	Name	Description
7:4	HOPERIOD[3:0]	Defines how many IFCLK cycles to assert not ready (HOCTL) to the external master in order to allow the synchronization interface to catch up.
3	HOSTATE	Defines what the state of the HOCTL signal should be in to assert not ready.
2:0	HOCTL[2:0]	Defines which of the six CTL[5:0] pins is the HOCTL signal that asserts not ready to the external master when the synchronization detects a potential overflow coming. It should coincide with the CTL[5:0] pin that is picked as the 'not ready' signal for the (macro-level) endpoint FIFO overflow protection.

15.13.12 FLOWSTBEDGE

GPIF Flow Master Strobe Edge Register

FLOWSTBEDGE							E6CC	
b7	b6	b5	b4	b3	b2	b1	b0	
0	0	0	0	0	0	FALLING	RISING	
R	R	R	R	R	R	R/W	RW	
0	0	0	0	0	0	0	1	

This register defines whether the Master strobe (see FLOWSTB) causes data to read or write on the falling edge, the rising edge, or both (double edge).

Bit	Name	Description
1	FALLING	0 Data is not transferred on the falling edge of Master strobe
		1 Data is transferred on the falling edge of Master strobe
0	RISING	0 Data is not transferred on the rising edge of Master strobe
		1 Data is transferred on the rising edge of Master strobe
To cause data to transfer on both edges of Master strobe, set both bits to '1'.		

15.13.13 FLOWSTBHPERIOD

GPIF Flow Master Strobe Half Period Register

FLOWSTBHPERIOD							E6CD
b7	b6	b5	b4	b3	b2	b1	b0
D7	D6	D5	D4	D3	D2	D1	D0
RW	RW	RW	RW	RW	RW	RW	RW
0	0	0	0	0	0	1	0

If the flow state is such that the GPIF is the master on the bus (FLOWSTB.SLAVE = 0) then Master strobe is one of the CTL[5:0] pins (see FLOWSTB). While in the flow state, if the flow logic (see FLOWLOGIC) evaluates in such a way that Master strobe toggles (see FLOWSTB.CTLTOGL), then this register defines the frequency at which it toggles.

More precisely, this register defines the half period of the Master strobe toggling frequency. Furthermore, to give the user a high degree of resolution this Master strobe, half period is defined in terms of half IFCLK periods. Therefore, if IFCLK is running at 48 MHz, this gives a resolution of 10.4 ns.

Bit	Name	Description
7:0	D[7:0]	Master Strobe Half-Period. Number of half IFCLK periods that define the half period of Master strobe (if it is a CTL pin). The value must be at least '2', meaning that the minimum half period for Master strobe is one full IFCLK cycle.

15.13.14 GPIFHOLDAMOUNT

GPIF Hold Amount Register

GPIFHOLDAMOUNT							E60C	
b7	b6	b5	b4	b3	b2	b1	b0	
0	0	0	0	0	0	HOLDTIME[1:0]		
R	R	R	R	R	R	RW	RW	
0	0	0	0	0	0	0	0	

For any transaction where the GPIF writes data onto FD[15:0], this register determines how long the data is held. Valid choices are 0, ½ or 1 IFCLK cycle. This register applies to any data written by the GPIF to FD[15:0], whether through a flow state or not.

For non-flow states, the hold amount is really just a delay of the normal (non-held) presentation of FD[15:0] by the amount specified in HOLDTIME[1:0].

For flow states in which the GPIF is the master on the bus (FLOWSTB.SLAVE = 0), the hold amount is with respect to the activating edge (see FLOW_MASTERSTB_EDGE) of Master strobe (which is a CTL pin in this case).

For flow states in which the GPIF is the slave on the bus (FLOWSTB.SLAVE = 1), the hold amount is really just a delay of the normal (non-held) presentation of FD[15:0] by the amount specified in HOLDTIME[1:0] in reaction to the activating edge of Master strobe (which is a RDY pin in this case). Note that the hold amount is NOT 'directly with respect to' the activating edge of Master strobe in this case; it is with respect to when the data normally comes out in response to Master strobe including any latency to synchronize Master strobe.

In all cases, the data is held for the desired amount even if the ensuing GPIF state calls for the data bus to be tri-stated. In other words the FD[15:0] output enable is held by the same amount as the data itself.

Bit	Name	Description
1:0	HOLDTIME[1:0]	GPIF Hold Time. 00 0 IFCLK cycles 01 ½ IFCLK cycle 10 1 IFCLK cycle 11 Reserved

15.13.15 GPIFTCBx

GPIF Transaction Count Byte Registers

GPIFTCB3 GPIF Transaction Count Byte 3 E6CE							
see Section 15.15							
b7	b6	b5	b4	b3	b2	b1	b0
TC31	TC30	TC29	TC28	TC27	TC26	TC25	TC24
R/W	R/W	R/W	R/W	R/W	R/W	R/W	R/W
0	0	0	0	0	0	0	0

GPIFTCB2 GPIF Transaction Count Byte 2 E6CF							
see Section 15.15							
b7	b6	b5	b4	b3	b2	b1	b0
TC23	TC22	TC21	TC20	TC19	TC18	TC17	TC16
R/W	R/W	R/W	R/W	R/W	R/W	R/W	R/W
0	0	0	0	0	0	0	0

GPIFTCB1 GPIF Transaction Count Byte 1 E6D0							
see Section 15.15							
b7	b6	b5	b4	b3	b2	b1	b0
TC15	TC14	TC13	TC12	TC11	TC10	TC9	TC8
R/W	R/W	R/W	R/W	R/W	R/W	R/W	R/W
0	0	0	0	0	0	0	0

GPIFTCB0 GPIF Transaction Count Byte 0 E6D1							
see Section 15.15							
b7	b6	b5	b4	b3	b2	b1	b0
TC7	TC6	TC5	TC4	TC3	TC2	TC1	TC0
R/W	R/W	R/W	R/W	R/W	R/W	R/W	R/W
0	0	0	0	0	0	0	1

Bit	Name	Description
31:0	TC31:0	GPIF Transaction Count.

Note Registers GPIFTCB3, GPIFTCB2, GPIFTCB1, and GPIFTCB0 represent the live update of GPIF transactions.

E6D2

15.13.16 EPxGPIFFLGSEL

Endpoint 2, 4, 6, 8 GPIF Flag Select Registers

EP2GPIFFLGSEL see Section 15.15		Endpoint 2 GPIF Flag Select						E6D2
EP4GPIFFLGSEL see Section 15.15		Endpoint 4 GPIF Flag Select						E6DA
EP6GPIFFLGSEL see Section 15.15		Endpoint 6 GPIF Flag Select						E6E2
EP8GPIFFLGSEL see Section 15.15		Endpoint 8 GPIF Flag Select						E6EA
b7	b6	b5	b4	b3	b2	b1	b0	
0	0	0	0	0	0	FS1	FS0	
R/W	R/W	R/W	R/W	R/W	R/W	R/W	R/W	
0	0	0	0	0	0	0	0	

Bit	Name	Description
1:0	FS[1:0]	<p>GPIF Flag Select.</p> <p>00 Programmable</p> <p>01 Empty</p> <p>10 Full</p> <p>11 Reserved</p> <p>Only one FIFO flag at a time may be made available to the GPIF as a control input. The FS1:FS0 bits select which flag is made available.</p>

15.13.17 EPxGPIFFSTOP

Endpoint 2, 4, 6, and 8 GPIF Stop Transaction Registers

EP2GPIFFSTOP		Endpoint 2 GPIF Stop Transaction						E6D3
EP4GPIFFSTOP		Endpoint 4 GPIF Stop Transaction						E6DB
EP6GPIFFSTOP		Endpoint 6 GPIF Stop Transaction						E6E3
EP8GPIFFSTOP		Endpoint 8 GPIF Stop Transaction						E6EB
b7	b6	b5	b4	b3	b2	b1	b0	
0	0	0	0	0	0	0	FIFO[2,4,6,8]FLAG	
R/W	R/W	R/W	R/W	R/W	R/W	R/W	R/W	
0	0	0	0	0	0	0	0	

Bit	Name	Description
0	EP[2,4,6,8]PF	Stop on Endpoint Programmable Flag. 1 GPIF transitions to 'DONE' state when the flag selected by EPxGPIFFLGSEL is asserted. 0 When transaction count has been met.

15.13.18 EPxGPIFTRIG

Endpoint 2, 4, 6, and 8 Slave FIFO GPIF Trigger Registers

EP2GPIFTRIG see Section 15.15		Endpoint 2 Slave FIFO GPIF Trigger						E6D4
EP4GPIFTRIG see Section 15.15		Endpoint 4 Slave FIFO GPIF Trigger						E6DC
EP6GPIFTRIG see Section 15.15		Endpoint 6 Slave FIFO GPIF Trigger						E6E4
EP8GPIFTRIG see Section 15.15		Endpoint 8 Slave FIFO GPIF Trigger						E6EC
b7	b6	b5	b4	b3	b2	b1	b0	
x	x	x	x	x	x	x	x	
W	W	W	W	W	W	W	W	
x	x	x	x	x	x	x	x	

Write 0xFF to this register to initiate a GPIF write. Read from this register to initiate a GPIF read.

15.13.19 XGPIFSGLDATH

GPIF Data High (16 Bit Mode) Register

XGPIFSGLDATH		GPIF Data HIGH (16 Bit Mode)						E6F0
b7	b6	b5	b4	b3	b2	b1	b0	
D15	D14	D13	D12	D11	D10	D9	D8	
R/W	R/W	R/W	R/W	R/W	R/W	R/W	R/W	
x	x	x	x	x	x	x	x	

Bit	Name	Description
7:0	D[15:8]	GPIF Data High. Contains the data written to or read from the FD[15:8] (PORTD) pins using the GPIF waveform.

15.13.20 XGPIFSGLDATL

Read/Write GPIF Data Low and Trigger Transaction Register

XGPIFSGLDATLX		Read/Write GPIF Data Low and Trigger Transaction						E6F1
b7	b6	b5	b4	b3	b2	b1	b0	
D7	D6	D5	D4	D3	D2	D1	D0	
R/W	R/W	R/W	R/W	R/W	R/W	R/W	R/W	
x	x	x	x	x	x	x	x	

Bit	Name	Description
7:0	D[7:0]	GPIF Data Low /Trigger GPIF Transaction. Contains the data written to or read from the FD[7:0] (PORTB) pins. Reading or writing low-byte triggers a GPIF transaction.

15.13.21 XGPIFSGLDATALNOX

Read GPIF Data Low, No Transaction Trigger Register

XGPIFSGLDATALNOX								Read GPIF Data Low, No Transaction Trigger								E6F2	
b7		b6		b5		b4		b3		b2		b1		b0			
D7		D6		D5		D4		D3		D2		D1		D0			
R		R		R		R		R		R		R		R			
x		x		x		x		x		x		x		x			

Bit	Name	Description
7:0	D[7:0]	GPIF Data Low / Do Not Trigger GPIF Transaction. Contains the data written to or read from the FD[7:0] (PORTB) pins. Read or write low byte does not trigger GPIF transaction.

15.13.22 GPIFREADYCFG

GPIF RDY Pin Configuration Register

GPIFREADYCFG		GPIF RDY Pin Configuration					E6F3
b7	b6	b5	b4	b3	b2	b1	b0
INTRDY	SAS	TCXRDY5	0	0	0	0	0
R/W	R/W	R/W	R	R	R	R	R
0	0	0	0	0	0	0	0

Bit	Name	Description
7	INTRDY	Force Ready Condition. Internal RDY. Functions as a sixth RDY input, controlled by the firmware instead of a RDY pin.
6	SAS	RDY Signal Connection to GPIF Input Logic. Synchronous/Asynchronous RDY signals. This bit controls how the RDY signals connect to the GPIF input logic. If the internal IFCLK is used to clock the GPIF, the RDY signals can make transitions in an asynchronous manner, i.e. not referenced to the internal clock. Setting SAS=0 causes the RDY inputs to pass through two flip-flops for synchronization purposes. If the RDY signals are synchronized to IFCLK, and obey the setup and hold times with respect to this clock, the user can set SAS=1, which causes the RDY signals to pass through a single flip flop.
5	TCXRDY5	TC Expiration Replaces RDY5. To use the transaction count expiration signal as a ready input to a waveform, set this bit to '1'. Setting this bit takes the place of the pin RDY5 in the decision point of the waveform. The default value of the bit is zero (in other words, the RDY5 from the pin prevails).

15.13.23 GPIFREADYSTAT

GPIF RDY Pin Status Register

GPIFREADYSTAT		GPIF RDY Pin Status						E6F4
b7	b6	b5	b4	b3	b2	b1	b0	
0	0	RDY5	RDY4	RDY3	RDY2	RDY1	RDY0	
R	R	R	R	R	R	R	R	
0	0	x	x	x	x	x	x	

Bit	Name	Description
Bit 5-0	RDY5:0	Current State of Ready Pins. RDYx. Instantaneous states of the RDY pins. The current state of the RDY[5:0] pins, sampled at each rising edge of the GPIF clock.

15.13.24 GPIFABORT

Abort GPIF Cycles Register

GPIFABORT		Abort GPIF						E6F5
b7	b6	b5	b4	b3	b2	b1	b0	
x	x	x	x	x	x	x	x	
W	W	W	W	W	W	W	W	
x	x	x	x	x	x	x	x	

Write 0xFF to immediately abort a GPIF transaction and transition to the Idle State.

15.14 Endpoint Buffers

15.14.1 EP0BUF

EP0 IN-OUT Buffer Register

EP0BUF		EP0 IN/OUT Buffer						E740-E77F
b7	b6	b5	b4	b3	b2	b1	b0	
D7	D6	D5	D4	D3	D2	D1	D0	
R/W	R/W	R/W	R/W	R/W	R/W	R/W	R/W	
X	X	X	X	X	X	X	X	

Bit	Name	Description
7:0	D[7:0]	EP0 Data. EP0 Data buffer (IN/OUT). 64 bytes.

15.14.2 EP1OUTBUF

Endpoint 1-OUT Buffer Register

EP1OUTBUF		EP1-OUT Buffer					E780-E7BF
b7	b6	b5	b4	b3	b2	b1	b0
D7	D6	D5	D4	D3	D2	D1	D0
R/W	R/W	R/W	R/W	R/W	R/W	R/W	R/W
X	X	X	X	X	X	X	X

Bit	Name	Description
7:0	D[7:0]	EP1-Out Data. EP1-Out Data buffer. 64 bytes.

15.14.3 EP1INBUF

Endpoint 1-IN Buffer Register

EP1INBUF		EP1-IN Buffer						E7C0-E7FF
b7	b6	b5	b4	b3	b2	b1	b0	
D7	D6	D5	D4	D3	D2	D1	D0	
R/W	R/W	R/W	R/W	R/W	R/W	R/W	R/W	
X	X	X	X	X	X	X	X	

Bit	Name	Description
7:0	D[7:0]	EP1-IN Buffer. EP1-IN Data buffer. 64 bytes.

15.14.4 EP2FIFOBUF

Endpoint 2/Slave FIFO Buffer Register

EP2FIFOBUF		512/1024-byte EP2/Slave FIFO Buffer					F000-F3FF	
b7	b6	b5	b4	b3	b2	b1	b0	
D7	D6	D5	D4	D3	D2	D1	D0	
R/W	R/W	R/W	R/W	R/W	R/W	R/W	R/W	
X	X	X	X	X	X	X	X	

Bit	Name	Description
7:0	D[7:0]	EP2 Data. 512/1024-byte EP2 buffer.

15.14.5 EP4FIFOBUF

512-byte Endpoint 4/Slave FIFO Buffer Register

EP4FIFOBUF		512-byte EP4/Slave FIFO Buffer						F400-F5FF
b7	b6	b5	b4	b3	b2	b1	b0	
D7	D6	D5	D4	D3	D2	D1	D0	
R/W	R/W	R/W	R/W	R/W	R/W	R/W	R/W	
X	X	X	X	X	X	X	X	

Bit	Name	Description
7:0	D[7:0]	EP4 Data. 512 byte EP4 buffer.

15.14.6 EP6FIFOBUF

512/1024-byte Endpoint 6/Slave FIFO Buffer Register

EP6FIFOBUF		512/1024-byte EP6/Slave FIFO Buffer					F800-FBFF	
b7	b6	b5	b4	b3	b2	b1	b0	
D7	D6	D5	D4	D3	D2	D1	D0	
R/W	R/W	R/W	R/W	R/W	R/W	R/W	R/W	
X	X	X	X	X	X	X	X	

Bit	Name	Description
7:0	D[7:0]	EP6 Data. 512/1024 byte EP6 buffer.

15.14.7 EP8FIFOBUF

512-byte Endpoint 8/Slave FIFO Buffer Register

EP8FIFOBUF		512-byte EP8/Slave FIFO Buffer						FC00-FDFF
b7	b6	b5	b4	b3	b2	b1	b0	
D7	D6	D5	D4	D3	D2	D1	D0	
R/W	R/W	R/W	R/W	R/W	R/W	R/W	R/W	
X	X	X	X	X	X	X	X	

Bit	Name	Description
7:0	D[7:0]	EP8 Data. 512 byte EP8 buffer.

15.15 Synchronization Delay

Under certain conditions, some read and write accesses to EZ-USB registers must be separated by a synchronization delay. The delay is necessary only under the following conditions:

- Between a write to any register in the 0xE600-0xE6FF range and a write to one of the registers in [Table 15-6](#).
- Between a write to one of the registers in [Table 15-6](#) and a read from any register in the 0xE600-0xE6FF range.

Table 15-6. Registers that Require a Synchronization Delay:

FIFORESET	FIFOPINPOLAR	ECCCFG
INPKTEND	EPxBCH:L	ECCRESET
EPxFIFOPFH:L	EPxAUTOINLENH:L	ECC1B0
EPxFIFOCFG	EPxGPIFFLGSEL	ECC1B1
PINFLAGSAB	PINFLAGSCD	ECC1B2
EPxFIFOIE	EPxFIFOIRQ	ECC2B0
GPIFIE	GPIFIRQ	ECC2B1
UDMACRCH:L	GPIFADRH:L	ECC2B2
GPIFTRIG	EPxGPIFTRIG	
OUTPKTEND	REVCTL	
GPIFTCB3	GPIFTCB2	
GPIFTCB1	GPIFTCB0	

The minimum delay length is a function of the IFCLK and CLKOUT (CPU Clock) frequencies, and is determined by the equation:

$$\text{Minimum Sync Delay, in CPU cycles} = \left\lceil 1.5 \times \left(\frac{\text{IFCLK Period}}{\text{CLKOUT Period}} + 1 \right) \right\rceil$$

Note
[n] means "round n upward" **Equation 1**

The required delay length is smallest when the CPU is running at its slowest speed (12 MHz, 83.2 ns/cycle) and IFCLK is running at its fastest speed (48 MHz, 20.8 ns/cycle). Under those conditions, the minimum required delay is:

$$\left\lceil 1.5 \times \left(\frac{20.8}{83.2} + 1 \right) \right\rceil = \lceil 1.5 \times (1.25) \rceil = \lceil 1.875 \rceil = 2 \text{ CPU Cycles}$$

Equation 2

The longest delay is required when the CPU is running at its fastest speed (48MHz, 20.8 ns/cycle) and IFCLK is running much slower (e.g., 5.2 MHz, 192 ns/cycle):

$$\left\lceil 1.5 \times \left(\frac{192}{20.8} + 1 \right) \right\rceil = \lceil 1.5 \times (10.23) \rceil = \lceil 15.3 \rceil = 16 \text{ CPU Cycles}$$

Equation 3

The most typical EZ-USB configuration, IFCLK and CLKOUT both running at 48 MHz, requires a minimum delay of:

$$\left\lceil 1.5 \times \left(\frac{20.8}{20.8} + 1 \right) \right\rceil = \lceil 1.5 \times (2) \rceil = \lceil 3 \rceil = 3 \text{ CPU Cycles}$$

Equation 4

The Frameworks firmware supplied with the EZ-USB Development Kit includes a macro, called SYNCDELAY, which implements the synchronization delay. The macro is in the file *fx2sdly.h*.

These delay cycles are in addition to the two clocks used by the MOVX instruction.

Appendix A. Descriptors for Full-Speed Mode



Table A-1 through Table A-25 show the descriptor data built into the EZ-USB logic. The tables are presented in the order that the bytes are stored.

Table A-1. Default USB Device Descriptor

Offset	Field	Description	Value
0	bLength	Length of this Descriptor = 18 bytes	12h
1	bDescriptorType	Descriptor Type = Device	01h
2	bcdUSB (L)	USB Specification Version 2.00 (L)	00h
3	bcdUSB (H)	USB Specification Version 2.00 (H)	02h
4	bDeviceClass	Device Class (FF is Vendor Specific)	FFh
5	bDeviceSubClass	Device Sub-class (FF is Vendor Specific)	FFh
6	bDeviceProtocol	Device Protocol (FF is Vendor Specific)	FFh
7	bMaxPacketSize0	Maximum Packet Size for EP0 = 64 bytes	40h
8	idVendor (L)	Vendor ID (L) Cypress Semi = 04B4H	B4h
9	idVendor (H)	Vendor ID (H)	04h
10	idProduct (L)	Product ID (L) FX2LP = 8613H, FX1 = 6473H	13h
11	idProduct (H)	Product ID (H)	86h
12	bcdDevice (L)	Device Release Number (BCD,L) (see individual data sheet)	xxh
13	bcdDevice (H)	Device Release Number (BCD,H) (see individual data sheet)	xxh
14	iManufacturer	Manufacturer Index String = None	00h
15	iProduct	Product Index String = None	00h
16	iSerialNumber	Serial number Index String = None	00h
17	bNumConfigurations	Number of Configurations in this Interface = 1	01h

The Device Descriptor specifies a MaxPacketSize of 64 bytes for endpoint 0, contains Cypress Semiconductor Vendor, Product and Release Number IDs, and uses no string indices. Release Number IDs (XX and YY) are found in individual Cypress Semiconductor data sheets. The EZ-USB logic returns this information response to a Get_Descriptor/Device host request.

Table A-2. Device Qualifier

Offset	Field	Description	Value
0	bLength	Length of this Descriptor = 10 bytes	0Ah
1	bDescriptorType	Descriptor Type = Device Qualifier	06h
2	bcdUSB (L)	USB Specification Version 2.00 (L)	00h
3	bcdUSB (H)	USB Specification Version 2.00 (H)	02h
4	bDeviceClass	Device Class (FF is Vendor Specific)	FFh
5	bDeviceSubClass	Device Sub-class (FF is Vendor Specific)	FFh
6	bDeviceProtocol	Device Protocol (FF is Vendor Specific)	FFh
7	bMaxPacketSize0	Maximum Packet Size for other speed = 64 bytes	40h
8	bNumConfigurations	Number of other Configurations = 1	01h
9	bReserved	Must be set to zero	00h

Table A-3. USB Default Configuration Descriptor

Offset	Field	Description	Value
0	bLength	Length of this Descriptor = 9 bytes	09h
1	bDescriptorType	Descriptor Type = Configuration	02h
2	wTotalLength (L)	Total Length (L) Including Interface and Endpoint Descriptors (171 total)	ABh
3	wTotalLength (H)	Total Length (H)	00h
4	bNumInterfaces	Number of Interfaces in this Configuration	01h
5	bConfigurationValue	Configuration Value Used by Set_Configuration Request to Select this interface	01h
6	iConfiguration	Index of String Describing this Configuration = None	00h
7	bmAttributes	Attributes - Bus Powered, No Wakeup	80h
8	MaxPower	Maximum Power - 100 mA	32h

The configuration descriptor includes a total length field (offset 2-3) that encompasses all interface and endpoint descriptors that follow the configuration descriptor. This configuration describes a single interface (offset 4). The host selects this configuration by issuing a Set_Configuration requests specifying configuration #1 (offset 5).

Table A-4. USB Default Interface 0, Alternate Setting 0

Offset	Field	Description	Value
0	bLength	Length of the Interface Descriptor	09h
1	bDescriptorType	Descriptor Type = Interface	04h
2	bInterfaceNumber	Zero based index of this interface = 0	00h
3	bAlternateSetting	Alternate Setting Value = 0	00h
4	bNumEndpoints	Number of endpoints in this interface (not counting EP0) = 0	00h
5	bInterfaceClass	Interface Class = Vendor Specific	FFh
6	bInterfaceSubClass	Interface Sub-class = Vendor Specific	FFh
7	bInterfaceProtocol	Interface Protocol = Vendor Specific	FFh
8	iInterface	Index to string descriptor for this interface = None	00h

Table A-5. USB Default Interface 0, Alternate Setting 1

Offset	Field	Description	Value
0	bLength	Length of this Interface Descriptor	09h
1	bDescriptorType	Descriptor Type = Interface	04h
2	bInterfaceNumber	Zero based index of this interface = 0	00h
3	bAlternateSetting	Alternate Setting Value = 1	01h
4	bNumEndpoints	Number of endpoints in this interface (not counting EP0) = 6	06h
5	bInterfaceClass	Interface Class = Vendor Specific	FFh
6	bInterfaceSubClass	Interface Sub-class = Vendor Specific	FFh
7	bInterfaceProtocol	Interface Protocol = Vendor Specific	FFh
8	iInterface	Index to string descriptor for this interface = None	00h

Table A-6. Endpoint Descriptor (EP1 out)

Offset	Field	Description	Value
0	bLength	Length of this Endpoint Descriptor	07h
1	bDescriptorType	Descriptor Type = Endpoint	05h
2	bEndpointAddress	Endpoint direction (1 is in) and address = OUT1	01h
3	bmAttributes	XFR Type = Bulk	02h
4	wMaxPacketSize (L)	Maximum Packet Size = 64 bytes	40h
5	WMaxPacketSize (H)	Maximum Packet Size - High	00h
6	bInterval	Polling Interval in Milliseconds (1 for ISO)	00h

Table A-7. Endpoint Descriptor (EP1 in)

Offset	Field	Description	Value
0	bLength	Length of this Endpoint Descriptor	07h
1	bDescriptorType	Descriptor Type = Endpoint	05h
2	bEndpointAddress	Endpoint Direction (1 is in) and address = IN1	81h
3	bmAttributes	XFR Type = BULK	02h
4	wMaxPacketSize (L)	Maximum Packet Size = 64 bytes	40h
5	WMaxPacketSize (H)	Maximum Packet Size - High	00h
6	bInterval	Polling Interval in Milliseconds (1 for iso)	00h

Table A-8. Endpoint Descriptor (EP2)

Offset	Field	Description	Value
0	bLength	Length of this Endpoint Descriptor	07h
1	bDescriptorType	Descriptor Type = Endpoint	05h
2	bEndpointAddress	Endpoint Direction (1 is in) and address = OUT2	02h
3	bmAttributes	XFR Type = BULK	02h
4	wMaxPacketSize (L)	Maximum Packet Size = 64 bytes	40h
5	WMaxPacketSize (H)	Maximum Packet Size - High	00h
6	bInterval	Polling Interval in Milliseconds (1 for iso)	00h

Table A-9. Endpoint Descriptor (EP4)

Offset	Field	Description	Value
0	bLength	Length of this Endpoint Descriptor	07h
1	bDescriptorType	Descriptor Type = Endpoint	05h
2	bEndpointAddress	Endpoint Direction (1 is in) and address = OUT4	04h
3	bmAttributes	XFR Type = BULK	02h
4	wMaxPacketSize (L)	Maximum Packet Size = 64 bytes	40h
5	WMaxPacketSize (H)	Maximum Packet Size - High	00h
6	bInterval	Polling Interval in Milliseconds (1 for iso)	00h

Table A-10. Endpoint Descriptor (EP6)

Offset	Field	Description	Value
0	bLength	Length of this Endpoint Descriptor	07h
1	bDescriptorType	Descriptor Type = Endpoint	05h
2	bEndpointAddress	Endpoint Direction (1 is in) and address = IN6	86h
3	bmAttributes	XFR Type = BULK	02h
4	wMaxPacketSize (L)	Maximum Packet Size = 64 bytes	40h
5	WMaxPacketSize (H)	Maximum Packet Size - High	00h
6	bInterval	Polling Interval in Milliseconds (1 for iso)	00h

Table A-11. Endpoint Descriptor (EP8)

Offset	Field	Description	Value
0	bLength	Length of this Endpoint Descriptor	07h
1	bDescriptorType	Descriptor Type = Endpoint	05h
2	bEndpointAddress	Endpoint Direction (1 is in) and address = IN8	88h
3	bmAttributes	XFR Type = BULK	02h
4	wMaxPacketSize (L)	Maximum Packet Size = 64 bytes	40h
5	WMaxPacketSize (H)	Maximum Packet Size - High	00h
6	bInterval	Polling Interval in Milliseconds (1 for iso)	00h

Table A-12. Interface Descriptor (Alt. Setting 2)

Offset	Field	Description	Value
0	bLength	Length of the Interface Descriptor	09h
1	bDescriptorType	Descriptor Type = Interface	04h
2	bInterfaceNumber	Zero based index of this interface = 0	00h
3	bAlternateSetting	Alternate Setting Value = 2	02h
4	bNumEndpoints	Number of endpoints in this interface (not counting EP0) = 6	06h
5	bInterfaceClass	Interface Class = Vendor Specific	FFh
6	bInterfaceSubClass	Interface Sub-class = Vendor Specific	FFh
7	bInterfaceProtocol	Interface Protocol = Vendor Specific	FFh
8	iInterface	Index to string descriptor for this interface = None	00h

Table A-13. Endpoint Descriptor (EP1 out)

Offset	Field	Description	Value
0	bLength	Length of this Endpoint Descriptor	07h
1	bDescriptorType	Descriptor Type = Endpoint	05h
2	bEndpointAddress	Endpoint Direction (1 is in) and address = OUT1	01h
3	bmAttributes	XFR Type = INT	03h
4	wMaxPacketSize (L)	Maximum Packet Size = 64 bytes	40h
5	WMaxPacketSize (H)	Maximum Packet Size - High	00h
6	bInterval	Polling Interval in Milliseconds (1 for iso)	0Ah

Table A-14. Endpoint Descriptor (EP1 in)

Offset	Field	Description	Value
0	bLength	Length of this Endpoint Descriptor	07h
1	bDescriptorType	Descriptor Type = Endpoint	05h
2	bEndpointAddress	Endpoint Direction (1 is in) and address = IN1	81h
3	bmAttributes	XFR Type = INT	03h
4	wMaxPacketSize (L)	Maximum Packet Size = 64 bytes	40h
5	WMaxPacketSize (H)	Maximum Packet Size - High	00h
6	bInterval	Polling Interval in Milliseconds (1 for iso)	0Ah

Table A-15. Endpoint Descriptor (EP2)

Offset	Field	Description	Value
0	bLength	Length of this Endpoint Descriptor	07h
1	bDescriptorType	Descriptor Type = Endpoint	05h
2	bEndpointAddress	Endpoint Direction (1 is in) and address = OUT2	02h
3	bmAttributes	XFR Type = INT	03h
4	wMaxPacketSize (L)	Maximum Packet Size = 64 bytes	40h
5	WMaxPacketSize (H)	Maximum Packet Size - High	00h
6	bInterval	Polling Interval in Milliseconds (1 for iso)	0Ah

Table A-16. Endpoint Descriptor (EP4)

Offset	Field	Description	Value
0	bLength	Length of this Endpoint Descriptor	07h
1	bDescriptorType	Descriptor Type = Endpoint	05h
2	bEndpointAddress	Endpoint Direction (1 is in) and address = OUT4	04h
3	bmAttributes	XFR Type = BULK	02h
4	wMaxPacketSize (L)	Maximum Packet Size = 64 bytes	40h
5	WMaxPacketSize (H)	Maximum Packet Size - High	00h
6	bInterval	Polling Interval in Milliseconds (1 for iso)	00h

Table A-17. Endpoint Descriptor (EP6)

Offset	Field	Description	Value
0	bLength	Length of this Endpoint Descriptor	07h
1	bDescriptorType	Descriptor Type = Endpoint	05h
2	bEndpointAddress	Endpoint Direction (1 is in) and address = IN6	86h
3	bmAttributes	XFR Type = INT	03h
4	wMaxPacketSize (L)	Maximum Packet Size = 64 bytes	40h
5	WMaxPacketSize (H)	Maximum Packet Size - High	00h
6	bInterval	Polling Interval in Milliseconds (1 for iso)	0Ah

Table A-18. Endpoint Descriptor (EP8)

Offset	Field	Description	Value
0	bLength	Length of this Endpoint Descriptor	07h
1	bDescriptorType	Descriptor Type = Endpoint	05h
2	bEndpointAddress	Endpoint Direction (1 is in) and address = IN8	88h
3	bmAttributes	XFR Type = BULK	02h
4	wMaxPacketSize (L)	Maximum Packet Size = 64 bytes	40h
5	WMaxPacketSize (H)	Maximum Packet Size - High	00h
6	bInterval	Polling Interval in Milliseconds (1 for iso)	00h

Table A-19. Interface Descriptor (Alt. Setting 3)

Offset	Field	Description	Value
0	bLength	Length of the Interface Descriptor	09h
1	bDescriptorType	Descriptor Type = Interface	04h
2	bInterfaceNumber	Zero based index of this interface = 0	00h
3	bAlternateSetting	Alternate Setting Value = 3	03h
4	bNumEndpoints	Number of endpoints in this interface (not counting EP0) = 6	06h
5	bInterfaceClass	Interface Class = Vendor Specific	FFh
6	bInterfaceSubClass	Interface Sub-class = Vendor Specific	FFh
7	bInterfaceProtocol	Interface Protocol = Vendor Specific	FFh
8	iInterface	Index to string descriptor for this interface = None	00h

Table A-20. Endpoint Descriptor (EP1 out)

Offset	Field	Description	Value
0	bLength	Length of this Endpoint Descriptor	07h
1	bDescriptorType	Descriptor Type = Endpoint	05h
2	bEndpointAddress	Endpoint Direction (1 is in) and address = OUT1	01h
3	bmAttributes	XFR Type = INT	03h
4	wMaxPacketSize (L)	Maximum Packet Size = 64 bytes	40h
5	WMaxPacketSize (H)	Maximum Packet Size - High	00h
6	bInterval	Polling Interval in Milliseconds (1 for iso)	0Ah

Table A-21. Endpoint Descriptor (EP1 in)

Offset	Field	Description	Value
0	bLength	Length of this Endpoint Descriptor	07h
1	bDescriptorType	Descriptor Type = Endpoint	05h
2	bEndpointAddress	Endpoint Direction (1 is in) and address = IN1	81h
3	bmAttributes	XFR Type = INT	03h
4	wMaxPacketSize (L)	Maximum Packet Size = 64 bytes	40h
5	WMaxPacketSize (H)	Maximum Packet Size - High	00h
6	bInterval	Polling Interval in Milliseconds (1 for iso)	0Ah

Table A-22. Endpoint Descriptor (EP2)

Offset	Field	Description	Value
0	bLength	Length of this Endpoint Descriptor	07h
1	bDescriptorType	Descriptor Type = Endpoint	05h
2	bEndpointAddress	Endpoint Direction (1 is in) and address = OUT2	02h
3	bmAttributes	XFR Type = ISO, No Synchronization, Data endpoint	01h
4	wMaxPacketSize (L)	Maximum Packet Size = 64 bytes	40h
5	WMaxPacketSize (H)	Maximum Packet Size - High	00h
6	bInterval	Polling Interval in Milliseconds (1 for iso)	01h

Table A-23. Endpoint Descriptor (EP4)

Offset	Field	Description	Value
0	bLength	Length of this Endpoint Descriptor	07h
1	bDescriptorType	Descriptor Type = Endpoint	05h
2	bEndpointAddress	Endpoint Direction (1 is in) and address = OUT4	04h
3	bmAttributes	XFR Type = BULK	02h
4	wMaxPacketSize (L)	Maximum Packet Size = 64 bytes	40h
5	WMaxPacketSize (H)	Maximum Packet Size - High	00h
6	bInterval	Polling Interval in Milliseconds (1 for iso)	00h

Table A-24. Endpoint Descriptor (EP6)

Offset	Field	Description	Value
0	bLength	Length of this Endpoint Descriptor	07h
1	bDescriptorType	Descriptor Type = Endpoint	05h
2	bEndpointAddress	Endpoint Direction (1 is in) and address = IN6	86h
3	bmAttributes	XFR Type = ISO, No Synchronization, Data Endpoint	01h
4	wMaxPacketSize (L)	Maximum Packet Size = 64 bytes	40h
5	WMaxPacketSize (H)	Maximum Packet Size - High	00h
6	bInterval	Polling Interval in Milliseconds (1 for iso)	01h

Table A-25. Endpoint Descriptor (EP8)

Offset	Field	Description	Value
0	bLength	Length of this Endpoint Descriptor	07h
1	bDescriptorType	Descriptor Type = Endpoint	05h
2	bEndpointAddress	Endpoint Direction (1 is in) and address = IN8	88h
3	bmAttributes	XFR Type = BULK	02h
4	wMaxPacketSize (L)	Maximum Packet Size = 64 bytes	40h
5	WMaxPacketSize (H)	Maximum Packet Size - High	00h
6	bInterval	Polling Interval in Milliseconds (1 for iso)	00h

Appendix B. Descriptors for High-Speed Mode



Table B-1 through Table B-25 show the descriptor data built into the FX2LP logic. The tables are presented in the order that the bytes are stored.

Table B-1. Device Descriptor

Offset	Field	Description	Value
0	bLength	Length of this Descriptor = 18 bytes	12h
1	bDescriptorType	Descriptor Type = Device	01h
2	bcdUSB (L)	USB Specification Version 2.00 (L)	00h
3	bcdUSB (H)	USB Specification Version 2.00 (H)	02h
4	bDeviceClass	Device Class (FF is Vendor-Specific)	FFh
5	bDeviceSubClass	Device Sub-class (FF is Vendor-Specific)	FFh
6	bDeviceProtocol	Device Protocol (FF is Vendor-Specific)	FFh
7	bMaxPacketSize0	Maximum Packet Size for EP0 = 63 bytes	40h
8	idVendor (L)	Vendor ID (L) Cypress Semi = 04B4H	B4h
9	idVendor (H)	Vendor ID (H)	04h
10	idProduct (L)	Product ID (L) FX2LP = 8613H	13h
11	idProduct (H)	Product ID (H)	86h
12	bcdDevice (L)	Device Release Number (BCD,L) (see individual data sheet)	xxh
13	bcdDevice (H)	Device Release Number (BCD,H) (see individual data sheet)	xxh
14	iManufacturer	Manufacturer Index String = None	00h
15	iProduct	Product Index String = None	00h
16	iSerialNumber	Serial Number Index String = None	00h
17	bNumConfigurations	Number of Configurations in this Interface = 1	01h

The Device Descriptor specifies a MaxPacketSize of 64 bytes for endpoint 0, contains Cypress Semiconductor Vendor, Product and Release Number IDs, and uses no string indices. Release Number IDs (XX and YY) are found in individual Cypress Semiconductor data sheets. The FX2LP logic returns this information response to a Get_Descriptor/Device host request.

Table B-2. Device Qualifier

Offset	Field	Description	Value
0	bLength	Length of this Descriptor = 10 bytes	0Ah
1	bDescriptorType	Descriptor Type = Device Qualifier	06h
2	bcdUSB (L)	USB Specification Version 2.00 (L)	00h
3	bcdUSB (H)	USB Specification Version 2.00 (H)	02h
4	bDeviceClass	Device Class (FF is vendor specific)	FFh
5	bDeviceSubClass	Device Sub-class (FF is vendor specific)	FFh
6	bDeviceProtocol	Device Protocol (FF is vendor specific)	FFh
7	bMaxPacketSize0	Maximum Packet Size for other speed = 64 bytes	40h
8	bNumConfigurations	Number of other Configurations = 1	01h
9	bReserved	Must be set to Zero	00h

Table B-3. Configuration Descriptor

Offset	Field	Description	Value
0	bLength	Length of this Descriptor = 9 bytes	09h
1	bDescriptorType	Descriptor Type = Configuration	02h
2	wTotalLength (L)	Total length (L) including Interface and Endpoint descriptors (171 total)	ABh
3	wTotalLength (H)	Total Length (H)	00h
4	bNumInterfaces	Number of Interfaces in this Configuration	01h
5	bConfigurationValue	Configuration value used by Set_Configuration Request to select this interface	01h
6	iConfiguration	Index of String Describing this Configuration = None	00h
7	bmAttributes	Attributes - Bus Powered, No Wakeup	80h
8	MaxPower	Maximum Power - 100 mA	32h

Table B-4. Interface Descriptor (Alt. Setting 0)

Offset	Field	Description	Value
0	bLength	Length of the Interface Descriptor	09h
1	bDescriptorType	Descriptor Type = Interface	04h
2	bInterfaceNumber	Zero based index of this interface = 0	00h
3	bAlternateSetting	Alternate Setting Value = 0	00h
4	bNumEndpoints	Number of endpoints in this interface (not counting EP0) = 0	00h
5	bInterfaceClass	Interface Class = Vendor Specific	FFh
6	bInterfaceSubClass	Interface Sub-class = Vendor Specific	FFh
7	bInterfaceProtocol	Interface Protocol = Vendor Specific	FFh
8	iInterface	Index to string descriptor for this interface = None	00h

Table B-5. Interface Descriptor (Alt. Setting 1)

Offset	Field	Description	Value
0	bLength	Length of the Interface Descriptor	09h
1	bDescriptorType	Descriptor Type = Interface	04h
2	bInterfaceNumber	Zero based index of this interface = 0	00h
3	bAlternateSetting	Alternate Setting Value = 1	01h
4	bNumEndpoints	Number of endpoints in this interface (not counting EP0) = 6	06h
5	bInterfaceClass	Interface Class = Vendor Specific	FFh
6	bInterfaceSubClass	Interface Sub-class = Vendor Specific	FFh
7	bInterfaceProtocol	Interface Protocol = Vendor Specific	FFh
8	iInterface	Index to string descriptor for this interface = None	00h

Table B-6. Endpoint Descriptor (EP1 out)

Offset	Field	Description	Value
0	bLength	Length of this Endpoint Descriptor	07h
1	bDescriptorType	Descriptor Type = Endpoint	05h
2	bEndpointAddress	Endpoint Direction (1 is in) and address = OUT1	01h
3	bmAttributes	XFR Type = BULK	02h
4	wMaxPacketSize (L)	Maximum Packet Size = 512 bytes	00h
5	WMaxPacketSize (H)	Maximum Packet Size - High	02h
6	bInterval	Polling Interval in Milliseconds (1 for iso)	00h

Table B-7. Endpoint Descriptor (EP1 in)

Offset	Field	Description	Value
0	bLength	Length of this Endpoint Descriptor	07h
1	bDescriptorType	Descriptor Type = Endpoint	05h
2	bEndpointAddress	Endpoint Direction (1 is in) and address = IN1	81h
3	bmAttributes	XFR Type = BULK	02h
4	wMaxPacketSize (L)	Maximum Packet Size = 512 bytes	00h
5	WMaxPacketSize (H)	Maximum Packet Size - High	02h
6	bInterval	Polling Interval in Milliseconds (1 for iso)	00h

Table B-8. Endpoint Descriptor (EP2)

Offset	Field	Description	Value
0	bLength	Length of this Endpoint Descriptor	07h
1	bDescriptorType	Descriptor Type = Endpoint	05h
2	bEndpointAddress	Endpoint Direction (1 is in) and address = OUT2	02h
3	bmAttributes	XFR Type = BULK	02h
4	wMaxPacketSize (L)	Maximum Packet Size = 512 bytes	00h
5	WMaxPacketSize (H)	Maximum Packet Size - High	02h
6	bInterval	Polling Interval in Milliseconds (1 for iso)	00h

Table B-9. Endpoint Descriptor (EP4)

Offset	Field	Description	Value
0	bLength	Length of this Endpoint Descriptor	07h
1	bDescriptorType	Descriptor Type = Endpoint	05h
2	bEndpointAddress	Endpoint Direction (1 is in) and address = OUT4	04h
3	bmAttributes	XFR Type = BULK	02h
4	wMaxPacketSize (L)	Maximum Packet Size = 512 bytes	00h
5	WMaxPacketSize (H)	Maximum Packet Size - High	02h
6	bInterval	Polling Interval in Milliseconds (1 for iso)	00h

Table B-10. Endpoint Descriptor (EP6)

Offset	Field	Description	Value
0	bLength	Length of this Endpoint Descriptor	07h
1	bDescriptorType	Descriptor Type = Endpoint	05h
2	bEndpointAddress	Endpoint Direction (1 is in) and address = IN6	86h
3	bmAttributes	XFR Type = BULK	02h
4	wMaxPacketSize (L)	Maximum Packet Size = 512 bytes	00h
5	WMaxPacketSize (H)	Maximum Packet Size - High	02h
6	bInterval	Polling Interval in Milliseconds (1 for iso)	00h

Table B-11. Endpoint Descriptor (EP8)

Offset	Field	Description	Value
0	bLength	Length of this Endpoint Descriptor	07h
1	bDescriptorType	Descriptor Type = Endpoint	05h
2	bEndpointAddress	Endpoint Direction (1 is in) and address = IN8	88h
3	bmAttributes	XFR Type = BULK	02h
4	wMaxPacketSize (L)	Maximum Packet Size = 512 bytes	00h
5	WMaxPacketSize (H)	Maximum Packet Size - High	02h
6	bInterval	Polling Interval in Milliseconds (1 for iso)	00h

Table B-12. Interface Descriptor (Alt. Setting 2)

Offset	Field	Description	Value
0	bLength	Length of the Interface Descriptor	09h
1	bDescriptorType	Descriptor Type = Interface	04h
2	bInterfaceNumber	Zero based index of this interface = 0	00h
3	bAlternateSetting	Alternate Setting Value = 2	02h
4	bNumEndpoints	Number of endpoints in this interface (not counting EP0) = 6	06h
5	bInterfaceClass	Interface Class = Vendor Specific	FFh
6	bInterfaceSubClass	Interface Sub-class = Vendor Specific	FFh
7	bInterfaceProtocol	Interface Protocol = Vendor Specific	FFh
8	iInterface	Index to string descriptor for this interface = None	00h

Table B-13. Endpoint Descriptor (EP1 out)

Offset	Field	Description	Value
0	bLength	Length of this Endpoint Descriptor	07h
1	bDescriptorType	Descriptor Type = Endpoint	05h
2	bEndpointAddress	Endpoint Direction (1 is in) and address = OUT1	01h
3	bmAttributes	XFR Type = INT	03h
4	wMaxPacketSize (L)	Maximum Packet Size = 64 bytes	40h
5	WMaxPacketSize (H)	Maximum Packet Size - High	00h
6	bInterval	Polling Interval in Milliseconds (1 for iso)	01h

Table B-14. Endpoint Descriptor (EP1 in)

Offset	Field	Description	Value
0	bLength	Length of this Endpoint Descriptor	07h
1	bDescriptorType	Descriptor Type = Endpoint	05h
2	bEndpointAddress	Endpoint Direction (1 is in) and address = IN1	81h
3	bmAttributes	XFR Type = INT	03h
4	wMaxPacketSize (L)	Maximum Packet Size = 64 bytes	40h
5	WMaxPacketSize (H)	Maximum Packet Size - High	00h
6	bInterval	Polling Interval in Milliseconds (1 for iso)	01h

Table B-15. Endpoint Descriptor (EP2)

Offset	Field	Description	Value
0	bLength	Length of this Endpoint Descriptor	07h
1	bDescriptorType	Descriptor Type = Endpoint	05h
2	bEndpointAddress	Endpoint Direction (1 is in) and address = OUT2	02h
3	bmAttributes	XFR Type = INT	03h
4	wMaxPacketSize (L)	Maximum Packet Size = 512 bytes	00h
5	WMaxPacketSize (H)	Maximum Packet Size - High	02h
6	bInterval	Polling Interval in Milliseconds (1 for iso)	01h

Table B-16. Endpoint Descriptor (EP4)

Offset	Field	Description	Value
0	bLength	Length of this Endpoint Descriptor	07h
1	bDescriptorType	Descriptor Type = Endpoint	05h
2	bEndpointAddress	Endpoint Direction (1 is in) and address = OUT4	04h
3	bmAttributes	XFR Type = BULK	02h
4	wMaxPacketSize (L)	Maximum Packet Size = 512 bytes	00h
5	WMaxPacketSize (H)	Maximum Packet Size - High	02h
6	bInterval	Polling Interval in Milliseconds (1 for iso)	00h

Table B-17. Endpoint Descriptor (EP6)

Offset	Field	Description	Value
0	bLength	Length of this Endpoint Descriptor	07h
1	bDescriptorType	Descriptor Type = Endpoint	05h
2	bEndpointAddress	Endpoint Direction (1 is in) and address = IN6	86h
3	bmAttributes	XFR Type = INT	03h
4	wMaxPacketSize (L)	Maximum Packet Size = 512 bytes	00h
5	WMaxPacketSize (H)	Maximum Packet Size - High	02h
6	bInterval	Polling Interval in Milliseconds (1 for iso)	01h

Table B-18. Endpoint Descriptor (EP8)

Offset	Field	Description	Value
0	bLength	Length of this Endpoint Descriptor	07h
1	bDescriptorType	Descriptor Type = Endpoint	05h
2	bEndpointAddress	Endpoint Direction (1 is in) and address = IN8	88h
3	bmAttributes	XFR Type = BULK	02h
4	wMaxPacketSize (L)	Maximum Packet Size = 512 bytes	00h
5	WMaxPacketSize (H)	Maximum Packet Size - High	02h
6	bInterval	Polling Interval in Milliseconds (1 for iso)	00h

Table B-19. Interface Descriptor (Alt. Setting 3)

Offset	Field	Description	Value
0	bLength	Length of the Interface Descriptor	09h
1	bDescriptorType	Descriptor Type = Interface	04h
2	bInterfaceNumber	Zero based index of this interface = 0	00h
3	bAlternateSetting	Alternate Setting Value = 3	03h
4	bNumEndpoints	Number of endpoints in this interface (not counting EP0) = 6	06h
5	bInterfaceClass	Interface Class = Vendor Specific	FFh
6	bInterfaceSubClass	Interface Sub-class = Vendor Specific	FFh
7	bInterfaceProtocol	Interface Protocol = Vendor Specific	FFh
8	iInterface	Index to string descriptor for this interface = None	00h

Table B-20. Endpoint Descriptor (EP1 out)

Offset	Field	Description	Value
0	bLength	Length of this Endpoint Descriptor	07h
1	bDescriptorType	Descriptor Type = Endpoint	05h
2	bEndpointAddress	Endpoint Direction (1 is in) and address = OUT1	01h
3	bmAttributes	XFR Type = INT	03h
4	wMaxPacketSize (L)	Maximum Packet Size = 64 bytes	40h
5	WMaxPacketSize (H)	Maximum Packet Size - High	00h
6	bInterval	Polling Interval in Milliseconds (1 for iso)	01h

Table B-21. Endpoint Descriptor (EP1 in)

Offset	Field	Description	Value
0	bLength	Length of this Endpoint Descriptor	07h
1	bDescriptorType	Descriptor Type = Endpoint	05h
2	bEndpointAddress	Endpoint Direction (1 is in) and address = IN1	81h
3	bmAttributes	XFR Type = INT	03h
4	wMaxPacketSize (L)	Maximum Packet Size = 64 bytes	40h
5	WMaxPacketSize (H)	Maximum Packet Size - High	00h
6	bInterval	Polling Interval in Milliseconds (1 for iso)	01h

Table B-22. Endpoint Descriptor (EP2)

Offset	Field	Description	Value
0	bLength	Length of this Endpoint Descriptor	07h
1	bDescriptorType	Descriptor Type = Endpoint	05h
2	bEndpointAddress	Endpoint Direction (1 is in) and address = OUT2	02h
3	bmAttributes	XFR Type = ISO, No Synchronization, Data endpoint	01h
4	wMaxPacketSize (L)	Maximum Packet Size = 512 bytes	00h
5	WMaxPacketSize (H)	Maximum Packet Size - High	02h
6	bInterval	Polling Interval in Milliseconds (1 for iso)	01h

Table B-23. Endpoint Descriptor (EP4)

Offset	Field	Description	Value
0	bLength	Length of this Endpoint Descriptor	07h
1	bDescriptorType	Descriptor Type = Endpoint	05h
2	bEndpointAddress	Endpoint Direction (1 is in) and address = OUT4	04h
3	bmAttributes	XFR Type = BULK	02h
4	wMaxPacketSize (L)	Maximum Packet Size = 512 bytes	00h
5	WMaxPacketSize (H)	Maximum Packet Size - High	02h
6	bInterval	Polling Interval in Milliseconds (1 for iso)	00h

Table B-24. Endpoint Descriptor (EP6)

Offset	Field	Description	Value
0	bLength	Length of this Endpoint Descriptor	07h
1	bDescriptorType	Descriptor Type = Endpoint	05h
2	bEndpointAddress	Endpoint Direction (1 is in) and address = IN6	86h
3	bmAttributes	XFR Type = ISO, No Synchronization, Data endpoint	01h
4	wMaxPacketSize (L)	Maximum Packet Size = 512 bytes	00h
5	WMaxPacketSize (H)	Maximum Packet Size - High	02h
6	bInterval	Polling Interval in Milliseconds (1 for iso)	01h

Table B-25. Endpoint Descriptor (EP8)

Offset	Field	Description	Value
0	bLength	Length of this Endpoint Descriptor	07h
1	bDescriptorType	Descriptor Type = Endpoint	05h
2	bEndpointAddress	Endpoint Direction (1 is in) and address = IN8	88h
3	bmAttributes	XFR Type = BULK	02h
4	wMaxPacketSize (L)	Maximum Packet Size = 512 bytes	00h
5	WMaxPacketSize (H)	Maximum Packet Size - High	02h
6	bInterval	Polling Interval in Milliseconds (1 for iso)	00h

Appendix C. Device Register Summary



The following table is a summary of all the device registers.

In the 'b7-b0' columns, bit positions that contain a '0' or a '1' cannot be written to and, when read, always return the value shown ('0' or '1'). Bit positions that contain '-' are available but unused.

The 'Default' column shows each register's hard reset value ('x' indicates 'undefined').

The 'Access' column indicates each register's read or write, or both accessibility.



Register Summary

Table C-1. EZ-USB® Registers and Buffers

Hex	Size	Name	Description	b7	b6	b5	b4	b3	b2	b1	b0	Default	Access	Notes
E400	128	WAVEDATA	GPIO Waveform Descriptor 0, 1, 2, 3 data	D7	D6	D5	D4	D3	D2	D1	D0	xxxxxxx	RW	Associated / pointed to by GPIWFSELECT
E480	128	reserved												
E600	1	CPUCS	GENERAL CONFIGURATION CPU Control and Status	0	0	PORTCSTB	CLKSPD1	CLKSPD0	CLKINV	CLKOE	8051RES	00000010	rrbbbb	PORTCSTB=1: reads/writes to PORTC generate RD# and WR# strobes CLKSPD1:0=8051 clock speed: 00=12, 01=24, 10=48, 11=X CLKINV=1 to invert CLKOUT signal CLKOE=1 to drive CLKOUT pin 8051RES=1 to reset 8051
E601	1	IFCONFIG	Interface Configuration (Ports, GPIF, slave FIFOs)	IFCLKSRC	3048MHZ	IFCLKOE	IFCLKPOL	ASYNC	GSTATE	IFCFG1	IFCFG0	10000000	RW	IFCLKSRC: FIFO/GPIF Clock Source: 0:external (IFGCLK pin); 1:internal 3048MHZ: Internal FIFO/GPIF clock freq: 0=30 MHz, 1=48 MHz IFCLKOE: FIFO/GPIF Clock Output Enable (on IFCLK pin) IFCLKPOL: FIFO/GPIF clock polarity (on IFCLK pin) ASYNC: 1=Slave FIFOs operate in asynchronous mode; 0=Slave FIFOs operate in synchronous mode GSTATE: 1=drive GSTATE[0:2] on PORTE[0:2] IFCFG1[0]: 00: ports; 01: reserved; 10: GPIF; 11: Slave FIFO (ext master)
E602	1	PINFLAGSA	Slave FIFO FLAGA and FLAGB Pin Configuration	FLAGB3	FLAGB2	FLAGB1	FLAGB0	FLAGA3	FLAGA2	FLAGA1	FLAGA0	00000000	RW	FLAGx[3:0] where x=A,B,C or D FIFO Flag; 0000: PF for FIFO selected by FIFOADR[1:0] pins. 0001-0011: reserved 0100: EP2.PF.0101: EP4.PF.0110: EP8.PF.0111: EP8.PF 1000: EP2.EF.1001: EP4.EF.1010: EP8.EF.1011: EP8.EF 1100: EP2.FF.1101: EP4.FF.1110: EP8.FF.1111: EP8.FF
E603	1	PINFLAGSCD	Slave FIFO FLAGC and FLAGD Pin Configuration	FLAGD3	FLAGD2	FLAGD1	FLAGD0	FLAGC3	FLAGC2	FLAGC1	FLAGC0	00000000	RW	Set flags and byte counts to default values; write 0x80 to NAK all transfers, then write NAKALL OR ed with FIFO number, then write 0x00 to restore normal operation
E604	1	FIFORESET	Restore FIFOs to default state	NAKALL	0	0	0	EP3	EP2	EP1	EP0	xxxxxxx	W	
E605	1	BREAKPT	Breakpoint Control	0	0	0	0	BREAK	BPPULSE	BPEN	0	00000000	rrrrbbb	
E606	1	BPADDRH	Breakpoint Address H	A15	A14	A13	A12	A11	A10	A9	A8	xxxxxxx	RW	
E607	1	BPADDRL	Breakpoint Address L	A7	A6	A5	A4	A3	A2	A1	A0	xxxxxxx	RW	
E608	1	UART230	230K baud internally generated reference clock	0	0	0	0	0	0	230UART1	230UART0	00000000	rrrrrrbb	If '1', overrides timer inputs to UART; 230 rate valid for any CPU clock rate.
E609	1	FIFOPINPOLAR	Slave FIFO Interface pins polarity	0	0	PKTEND	SLOE	SLRD	SLWR	EF	FF	00000000	rrbbbb	0=active low, 1=active high
E60A	1	REVID	Chip Revision	rV7	rV6	rV5	rV4	rV3	rV2	rV1	rV0	RevA 00000001	R	Chip revision number
E60B	1	REVCTL	Chip Revision Control	0	0	0	0	0	0	dyn_out	enth_pkt	00000000	rrrrrrbb	



Table C-1. EZ-USB® Registers and Buffers (continued)

Hex	Size	Name	Description	b7	b6	b5	b4	b3	b2	b1	b0	Default	Access	Notes
E60C	1	GP1FHOLDAMOUNT	MSTB Hold Time (for UDMA)	0	0	0	0	0	0	HOLDTIME1	HOLDTIME0	00000000	rrrrrrbb	
	3	reserved												
ENDPOINT CONFIGURATION														
E610	1	EP1OUTCFG	Endpoint 1-OUT Configuration	VALID	0	TYPE1	TYPE0	0	0	0	0	10100000	brbrrrr	Default: BULK OUT 64
E611	1	EP1INCFG	Endpoint 1-IN Configuration	VALID	0	TYPE1	TYPE0	0	0	0	0	10100000	brbrrrr	Default: BULK IN 64
E612	1	EP2CFG	Endpoint 2 Configuration	VALID	DIR	TYPE1	TYPE0	SIZE	0	BUF1	BUF0	10100010	bbbbrrbb	Default: BULK OUT 512 double buffered
E613	1	EP4CFG	Endpoint 4 Configuration	VALID	DIR	TYPE1	TYPE0	0	0	0	0	10100000	bbbbrrrr	Default: BULK OUT (512 double buffered only choice)
E614	1	EP6CFG	Endpoint 6 Configuration	VALID	DIR	TYPE1	TYPE0	SIZE	0	BUF1	BUF0	11100010	bbbbrrbb	Default: BULK IN 512 double buffered
E615	1	EP8CFG	Endpoint 8 Configuration	VALID	DIR	TYPE1	TYPE0	0	0	0	0	11100000	bbbbrrrr	Default: BULK IN (512 double buffered only choice)
	2	reserved												
E618	1	EP2FIFOCFG see Section 15.15	Endpoint 2 / slave FIFO configuration	0	INFM1	OEP1	AUTOOUT	AUTOIN	ZEROLENIN	0	WORDWIDE	00000101	rbbbbrrb	INFM1 (in FULL flag minus 1): 0=normal, 1=flags active one byte early
E619	1	EP4FIFOCFG see Section 15.15	Endpoint 4 / slave FIFO configuration	0	INFM1	OEP1	AUTOOUT	AUTOIN	ZEROLENIN	0	WORDWIDE	00000101	rbbbbrrb	OEP1 (Out EMPTY flag plus 1): 0=normal, 1=flags active one byte early
E61A	1	EP6FIFOCFG see Section 15.15	Endpoint 6 / slave FIFO configuration	0	INFM1	OEP1	AUTOOUT	AUTOIN	ZEROLENIN	0	WORDWIDE	00000101	rbbbbrrb	AUTOOUT=1 —valid OUT packet automatically becomes part of OUT FIFO
E61B	1	EP8FIFOCFG see Section 15.15	Endpoint 8 / slave FIFO configuration	0	INFM1	OEP1	AUTOOUT	AUTOIN	ZEROLENIN	0	WORDWIDE	00000101	rbbbbrrb	AUTOOUT=0 —8051 decides if to commit data to the OUT FIFO
E61C	4	reserved												AUTOIN=1 —SIE packetizes/dispatches IN-FIFO data using EPx-AUTOINLEN AUTOIN=0 —8051 dispatches an IN packet by writing byte count WORDWIDE=1 : PB=FD[0:7], PD=FD[8:15]; =1: PB=FD[0:7], PD=PD ZEROLENIN : 0=disable; 1=send zero len pkt on PKTEND— if any of the four WORD-WIDE bits=1, core configures PD as FD15:8
E620	1	EP2AUTOINLENH see Section 15.15	Endpoint 2 AUTOIN Packet Length H	0	0	0	0	0	PL 10	PL 9	PL 8	00000010	rrrrrrbb	Default is 512 byte packets; can set smaller IN packets
E621	1	EP2AUTOINLENL see Section 15.15	Endpoint 2 AUTOIN Packet Length L	PL 7	PL 6	PL 5	PL 4	PL 3	PL 2	PL 1	PL 0	00000000	RW	SIE divides IN-FIFO data into this-length packets when AUTOIN=1. When AUTOIN=0, 8051 loads a byte count for every packet (in EPxCHL).
E622	1	EP4AUTOINLENH see Section 15.15	Endpoint 4 AUTOIN Packet Length H	0	0	0	0	0	0	0	0	00000010	rrrrrrbb	
E623	1	EP4AUTOINLENL see Section 15.15	Endpoint 4 AUTOIN Packet Length L	PL 7	PL 6	PL 5	PL 4	PL 3	PL 2	PL 1	PL 0	00000000	RW	
E624	1	EP6AUTOINLENH see Section 15.15	Endpoint 6 AUTOIN Packet Length H	0	0	0	0	0	PL 10	PL 9	PL 8	00000010	rrrrrrbb	
E625	1	EP6AUTOINLENL see Section 15.15	Endpoint 6 AUTOIN Packet Length L	PL 7	PL 6	PL 5	PL 4	PL 3	PL 2	PL 1	PL 0	00000000	RW	
E626	1	EP8AUTOINLENH see Section 15.15	Endpoint 8 AUTOIN Packet Length H	0	0	0	0	0	0	0	0	00000010	rrrrrrbb	EP2, 6 can have 1024 max bytes, EP4, 8 can have 512 max bytes. These registers are only used for AUTOIN
E627	1	EP8AUTOINLENL see Section 15.15	Endpoint 8 AUTOIN Packet Length L	PL 7	PL 6	PL 5	PL 4	PL 3	PL 2	PL 1	PL 0	00000000	RW	



Device Register Summary

Table C-1. EZ-USB® Registers and Buffers (continued)

Hex	Size	Name	Description	b7	b6	b5	b4	b3	b2	b1	b0	Default	Access	Notes
E628	1	ECCCFG	ECC Configuration	0	0	0	0	0	0	0	ECCM	00000000	rrrrrrbb	ECCM selects the ECC block size mode.
E629	1	ECCRESET	ECC Reset	x	x	x	x	x	x	x	x	00000000	W	ECC RESET: This is an action register; it resets the ecc calculation.
E62A	1	ECC1B0	ECC1 Byte 0	LINE15	LINE14	LINE13	LINE12	LINE11	LINE10	LINE9	LINE8	00000000	R	LINE[15:8]: This is the second eight bits of the line parity
E62B	1	ECC1B1	ECC1 Byte 1	LINE7	LINE6	LINE5	LINE4	LINE3	LINE2	LINE1	LINE0	00000000	R	LINE[7:0]: This is the lower eight bits of the line parity
E62C	1	ECC1B2	ECC1 Byte 2	COL5	COL4	COL3	COL2	COL1	COL0	LINE17	LINE16	00000000	R	COL[5:0]: This is the 6 bit column parity LINE[17:16]: This is the upper two bits of the line parity
E62D	1	ECC2B0	ECC2 Byte 0	LINE15	LINE14	LINE13	LINE12	LINE11	LINE10	LINE9	LINE8	00000000	R	LINE[15:8]: This is the second eight bits of the line parity
E62E	1	ECC2B1	ECC2 Byte 1	LINE7	LINE6	LINE5	LINE4	LINE3	LINE2	LINE1	LINE0	00000000	R	LINE[7:0]: This is the lower eight bits of the line parity
E62F	1	ECC2B2	ECC2 Byte 2	COL5	COL4	COL3	COL2	COL1	COL0	0	0	00000000	R	COL[5:0]: This is the 6-bit column parity
E630	1	EP2FIFOPFH see Section 15.15	Endpoint 2 / slave FIFO Programmable Flag H	DECIS	PKTSTAT	IN:PKT[2] OUT:PPC[12] PFC11	IN:PKT[1] OUT:PPC[11] PFC10	IN:PKT[0] OUT:PPC[10] PFC9	0	PFC9	PFC8	10011000	bbbbrrbb	For complete details about this register, refer to Section .
E630	1	EP2FIFOPFH see Section 15.15	Endpoint 2 / slave FIFO Programmable Flag L	DECIS	PKTSTAT	OUT:PPC[12]	OUT:PPC[11]	OUT:PPC[10]	0	PFC9	PFC8	10011000	bbbbrrbb	
E631	1	EP2FIFOPFL see Section 15.15	Endpoint 2 / slave FIFO Programmable Flag L	IN:PKT[1] OUT:PPC[7]	IN:PKT[0] OUT:PPC[6]	PFC5	PFC4	PFC3	PFC2	PFC1	PFC0	00000000	RW	
E631	1	EP2FIFOPFL see Section 15.15	Endpoint 2 / slave FIFO Programmable Flag H	IN:PKT[1] OUT:PPC[7]	IN:PKT[0] OUT:PPC[6]	PFC5	PFC4	PFC3	PFC2	PFC1	PFC0	00000000	RW	
E632	1	EP4FIFOPFH see Section 15.15	Endpoint 4 / slave FIFO Programmable Flag H	DECIS	PKTSTAT	0	IN:PKT[1] OUT:PPC[10] OUT:PPC[9]	IN:PKT[0] OUT:PPC[9]	0	0	PFC8	10011000	brbrrbb	Maximum 1024
E632	1	EP4FIFOPFH see Section 15.15	Endpoint 4 / slave FIFO Programmable Flag L	DECIS	PKTSTAT	0	OUT:PPC[10]	OUT:PPC[9]	0	0	PFC8	10011000	brbrrbb	Maximum 1024
E633	1	EP4FIFOPFL see Section 15.15	Endpoint 4 / slave FIFO Programmable Flag L	IN:PKT[1] OUT:PPC[7]	IN:PKT[0] OUT:PPC[6]	PFC5	PFC4	PFC3	PFC2	PFC1	PFC0	00000000	RW	
E633	1	EP4FIFOPFL see Section 15.15	Endpoint 4 / slave FIFO Programmable Flag H	IN:PKT[1] OUT:PPC[7]	IN:PKT[0] OUT:PPC[6]	PFC5	PFC4	PFC3	PFC2	PFC1	PFC0	00000000	RW	
E634	1	EP6FIFOPFH see Section 15.15	Endpoint 6 / slave FIFO Programmable Flag H	DECIS	PKTSTAT	DECIS	PKTSTAT	IN:PKT[2] OUT:PPC[12] PFC11	IN:PKT[1] OUT:PPC[11] PFC10	IN:PKT[0] OUT:PPC[10] PFC9	IN:PKT[2] OUT:PPC[8]	00011000	bbbbrrbb	For complete details about this register, refer to 'Endpoint 2, 6/Slave FIFO Programmable Level Flag High Registers' on page 244.
E634	1	EP6FIFOPFH see Section 15.15	Endpoint 6 / slave FIFO Programmable Flag L	DECIS	PKTSTAT	OUT:PPC[12]	OUT:PPC[11]	OUT:PPC[10]	0	PFC9	PFC8	00011000	bbbbrrbb	
E635	1	EP6FIFOPFL see Section 15.15	Endpoint 6 / slave FIFO Programmable Flag L	IN:PKT[1] OUT:PPC[7]	IN:PKT[0] OUT:PPC[6]	PFC5	PFC4	PFC3	PFC2	PFC1	PFC0	00000000	RW	
E635	1	EP6FIFOPFL see Section 15.15	Endpoint 6 / slave FIFO Programmable Flag H	IN:PKT[1] OUT:PPC[7]	IN:PKT[0] OUT:PPC[6]	PFC5	PFC4	PFC3	PFC2	PFC1	PFC0	00000000	RW	
E636	1	EP8FIFOPFH see Section 15.15	Endpoint 8 / slave FIFO Programmable Flag H	DECIS	PKTSTAT	DECIS	PKTSTAT	IN:PKT[1] OUT:PPC[10] OUT:PPC[9]	IN:PKT[0] OUT:PPC[9]	0	PFC8	00011000	brbrrbb	Maximum 1024
E636	1	EP8FIFOPFH see Section 15.15	Endpoint 8 / slave FIFO Programmable Flag L	DECIS	PKTSTAT	0	OUT:PPC[10]	OUT:PPC[9]	0	0	PFC8	00011000	brbrrbb	Maximum 1024
E637	1	EP8FIFOPFL see Section 15.15	Endpoint 8 / slave FIFO Programmable Flag L	IN:PKT[1] OUT:PPC[7]	IN:PKT[0] OUT:PPC[6]	PFC5	PFC4	PFC3	PFC2	PFC1	PFC0	00000000	RW	
E637	1	EP8FIFOPFL see Section 15.15	Endpoint 8 / slave FIFO Programmable Flag H	IN:PKT[1] OUT:PPC[7]	IN:PKT[0] OUT:PPC[6]	PFC5	PFC4	PFC3	PFC2	PFC1	PFC0	00000000	RW	
E640	1	EP2ISOINPKTS	EP2 (if ISO) IN Packets per frame (1-3)	AADJ	0	0	0	0	0	INPPF1	INPPF0	00000001	brrrrrbb	INPPF1:0: 00=illegal, 01=1 per frame, 10=2 per frame, 11=3 per frame
E641	1	EP4ISOINPKTS	EP4 (if ISO) IN Packets per frame (1)	AADJ	0	0	0	0	0	INPPF1	INPPF0	00000001	brrrrrbb	
E642	1	EP6ISOINPKTS	EP6 (if ISO) IN Packets per frame (1-2)	AADJ	0	0	0	0	0	INPPF1	INPPF0	00000001	brrrrrbb	



Table C-1. EZ-USB® Registers and Buffers (continued)

Hex	Size	Name	Description	b7	b6	b5	b4	b3	b2	b1	b0	Default	Access	Notes
E643	1	EP8ISOINPKTS	EP8 (if ISO) IN Packets per frame (1)	AADJ	0	0	0	0	0	INPPF1	INPPF0	00000001	brrrrrr	
E644	4	reserved												
E648	1	INPKTEND see Section 15.15	Force IN Packet End	Skip	0	0	0	EP3	EP2	EP1	EP0	xxxxxxx	W	Same function as slave interface PKTEND pin, but 8051 controls dispatch of IN. Typically used after a GPIF FIFO transaction completes to send jagged edge pkt. user needs to check status of FIFO full flag for available buffer before doing PKTEND
E649	7	OUTPKTEND	Force OUT Packet End	Skip	0	0	0	EP3	EP2	EP1	EP0	xxxxxxx	W	REVCTL_0=1 to enable this feature
INTERRUPTS														
E650	1	EP2FIFOIE see Section 15.15	Endpoint 2 slave FIFO Flag Interrupt Enable	0	0	0	0	EDGEPF	PF	EF	FF	00000000	RW	EDGEPF=0; Rising edge EDGEPF=1; Falling edge
E651	1	EP2FIFOIRQ see Section 15.15	Endpoint 2 slave FIFO Flag Interrupt Request	0	0	0	0	0	PF	EF	FF	00000000	rrrrbbb	Note: Can only reset, can not set
E652	1	EP4FIFOIE see Section 15.15	Endpoint 4 slave FIFO Flag Interrupt Enable	0	0	0	0	EDGEPF	PF	EF	FF	00000000	RW	
E653	1	EP4FIFOIRQ see Section 15.15	Endpoint 4 slave FIFO Flag Interrupt Request	0	0	0	0	0	PF	EF	FF	00000000	rrrrbbb	Note: Can only reset, can not set
E654	1	EP6FIFOIE see Section 15.15	Endpoint 6 slave FIFO Flag Interrupt Enable	0	0	0	0	EDGEPF	PF	EF	FF	00000000	RW	
E655	1	EP6FIFOIRQ see Section 15.15	Endpoint 6 slave FIFO Flag Interrupt Request	0	0	0	0	0	PF	EF	FF	00000000	rrrrbbb	Note: Can only reset, can not set
E656	1	EP8FIFOIE see Section 15.15	Endpoint 8 slave FIFO Flag Interrupt Enable	0	0	0	0	EDGEPF	PF	EF	FF	00000000	RW	
E657	1	EP8FIFOIRQ see Section 15.15	Endpoint 8 slave FIFO Flag Interrupt Request	0	0	0	0	0	PF	EF	FF	00000000	rrrrbbb	Note: Can only reset, can not set
E658	1	IBNIE	IN-BULK-NAK Interrupt Enable	0	0	EP8	EP6	EP4	EP2	EP1	EP0	00000000	RW	1 = clear request, 0=no effect, note: can only reset, can not set
E659	1	IBNIRQ	IN-BULK-NAK Interrupt Request	0	0	EP8	EP6	EP4	EP2	EP1	EP0	00xxxxxx	rbbbbbb	OUT endpoint was pinged and NAK'd
E65A	1	NAKIE	Endpoint Ping-NAK / IBN Interrupt Enable	EP8	EP6	EP4	EP2	EP1	EP0	0	IBN	00000000	RW	note: can only reset, can not set
E65B	1	NAKIRQ	Endpoint Ping-NAK / IBN Interrupt Request	EP8	EP6	EP4	EP2	EP1	EP0	0	IBN	xxxxx0x	bbbbbbb	
E65C	1	USBIE	USB Int Enables	0	EPACK	HSGRANT	URES	SUSP	SUTOK	SOF	SUDAV	00000000	RW	
E65D	1	USBIRQ	USB Interrupt Requests	0	EPACK	HSGRANT	URES	SUSP	SUTOK	SOF	SUDAV	0xxxxxxx	rbbbbbb	1 = clear request, 0=no effect, note: can only reset, can not set
E65E	1	EPIE	Endpoint Interrupt Enables	EP8	EP6	EP4	EP2	EPIOUT	EPIIN	EPOUT	EPOIN	00000000	RW	
E65F	1	EPIRQ	Endpoint Interrupt Requests	EP8	EP6	EP4	EP2	EPIOUT	EPIIN	EPOUT	EPOIN	00000000	RW	1 = clear request, 0=no effect, note: can only reset, can not set
E660	1	GPIFIE see Section 15.15	GPIF Interrupt Enable	0	0	0	0	0	0	GPIFWF	GPIFDONE	00000000	RW	WF=8051 'hook' in waveform, DONE=returned to IDLE state
E661	1	GPIFIRQ see Section 15.15	GPIF Interrupt Request	0	0	0	0	0	0	GPIFWF	GPIFDONE	000000xx	RW	Write '1' to clear
E662	1	USBERRIE	USB Error Interrupt Enables	ISOEP8	ISOEP6	ISOEP4	ISOEP2	0	0	0	ERRLIMIT	00000000	RW	ISO endpoint error: PID sequence error or dropped packet (no available buffer)
E663	1	USBERRIRQ	USB Error Interrupt Requests	ISOEP8	ISOEP6	ISOEP4	ISOEP2	0	0	0	ERRLIMIT	0000000x	bbbbrrb	Note: Can only reset, can not set
E664	1	ERRCNTLIM	USB Error counter and limit	EC3	EC2	EC1	EC0	LIMIT3	LIMIT2	LIMIT1	LIMIT0	xxxx0100	rrrrbbb	Default limit count is 4
E665	1	CLRERRCNT	Clear Error Counter EC3:0	x	x	x	x	x	x	x	x	xxxxxxx	W	
E666	1	INT2IVEC	Interrupt 2 (USB) Autovector	0	12V4	12V3	12V2	12V1	12V0	0	0	00000000	R	
E667	1	INT4IVEC	Interrupt 4 (slave FIFO and GPIF) Autovector	1	0	14V3	14V2	14V1	14V0	0	0	10000000	R	



Device Register Summary

Table C-1. EZ-USB® Registers and Buffers (continued)

Hex	Size	Name	Description	b7	b6	b5	b4	b3	b2	b1	b0	Default	Access	Notes
E668	1	INTSETUP	Interrupt 2 and 4 Setup	0	0	0	0	AV2EN	0	INT4SRC	AV4EN	00000000	RW	INT4IN=0; INT4 from pin; 1: INT4 from FIFO/GPIF interrupts
E669	7	reserved												
INPUT / OUTPUT														
E670	1	PORTACFG	I/O PORTA Alternate Configuration	FLAGD	SLCS	0	0	0	0	INT1	INT0	00000000	RW	
E671	1	PORTCCFG	I/O PORTC Alternate Configuration	GPIFA7	GPIFA6	GPIFA5	GPIFA4	GPIFA3	GPIFA2	GPIFA1	GPIFA0	00000000	RW	
E672	1	PORTECFG	I/O PORTE Alternate Configuration	GPIFA8	T2EX	INT6	RXD1OUT	RXD0OUT	T2OUT	T1OUT	T0OUT	00000000	RW	GSTATE bit = 1 overrides bits 2-0.
E673	1	reserved												
E674	1	I2CS	I2C-Compatible Bus Control and Status	START	STOP	LASTRD	ID1	ID0	BERR	ACK	DONE	000xx000	bbbbrrrr	
E675	1	I2DAT	I2C-Compatible Bus Data	d7	d6	d5	d4	d3	d2	d1	d0	xxxxxxx	RW	
E676	1	I2CTL	I2C-Compatible Bus Control	0	0	0	0	0	0	STOPIE	400KHZ	00000000	RW	
E67B	1	XAUTODAT1	Autopt1 MOVX access, when APTREN=1	D7	D6	D5	D4	D3	D2	D1	D0	xxxxxxx	RW	AUTOPTRESETUP bit location
E67C	1	XAUTODAT2	Autopt2 MOVX access, when APTREN=1	D7	D6	D5	D4	D3	D2	D1	D0	xxxxxxx	RW	AUTOPTRESETUP bit location
UDMA CRC														
E67D	1	UDMACRCH	UDMA CRC MSB	CRC15	CRC14	CRC13	CRC12	CRC11	CRC10	CRC9	CRC8	01001010	RW	
E67E	1	UDMACRCL	UDMA CRC LSB	CRC7	CRC6	CRC5	CRC4	CRC3	CRC2	CRC1	CRC0	10111010	RW	
E67F	1	UDMACRC-QUALIFIER	UDMA CRC Qualifier	QENABLE	0	0	0	QSTATE	Q SIGNAL2	Q SIGNAL1	Q SIGNAL0	00000000	bbbbbbbb	
USB CONTROL														
E680	1	USBCS	USB Control and Status	HSM	0	0	0	DISCON	NOSYNSOF	RENUM	SIGRSUME	x0000000	rrrrbbbb	
E681	1	SUSPEND	Put chip into suspend	x	x	x	x	x	x	x	x	xxxxxxx	W	Write any value to suspend
E682	1	WAKEUPCS	WakeUp Control and Status	WU2	WU	WU2POL	WUJOL	0	DPEN	WU2EN	WUEN	xx000101	bbbbbbbb	
E683	1	TOGCTL	Toggle Control	Q	S	R	IO	EP3	EP2	EP1	EP0	x0000000	rrrrbbbb	
E684	1	USBFRAMEH	USB Frame count H	0	0	0	0	0	FC10	FC9	FC8	0000xxxx	R	
E685	1	USBFRAMEL	USB Frame count L	FC7	FC6	FC5	FC4	FC3	FC2	FC1	FC0	xxxxxxx	R	
E686	1	MICROFRAME	Microframe count, 0-7	0	0	0	0	0	MF2	MF1	MF0	0000xxxx	R	
E687	1	FNADDR	USB Function address	0	FA6	FA5	FA4	FA3	FA2	FA1	FA0	0xxxxxxx	R	
E688	2	reserved												
ENDPOINTS														
E68A	1	EP0BCH	Endpoint 0 Byte Count H	(BC15)	(BC14)	(BC13)	(BC12)	(BC11)	(BC10)	(BC9)	(BC8)	xxxxxxx	RW	Even though the EP0 buffer is only 64 bytes, the EP0 byte count is expanded to 16-bits to allow using the Autoptr with a custom length. Instead of USB-dictated length (from Setup Data Packet) and number of requested bytes).
E68B	1	EP0BCL	Endpoint 0 Byte Count L	(BC7)	BC6	BC5	BC4	BC3	BC2	BC1	BC0	xxxxxxx	RW	The byte count bits in parentheses apply only when SDPAUTO = 0
E68C	1	reserved												
E68D	1	EP1OUTBC	Endpoint 1 OUT Byte Count	0	BC6	BC5	BC4	BC3	BC2	BC1	BC0	0xxxxxxx	RW	
E68E	1	reserved												
E68F	1	EP1INBC	Endpoint 1 IN Byte Count	0	BC6	BC5	BC4	BC3	BC2	BC1	BC0	0xxxxxxx	RW	



Table C-1. EZ-USB® Registers and Buffers (continued)

Hex	Size	Name	Description	b7	b6	b5	b4	b3	b2	b1	b0	Default	Access	Notes
E690	1	EP2BCH see Section 15.15	Endpoint 2 Byte Count H	0	0	0	0	0	BC10	BC9	BC8	00000xxx	RW	EP2,6 can be 512 or 1024 EP4,8 are 512 only
E691	1	EP2BCL see Section 15.15	Endpoint 2 Byte Count L	BC7/SKIP	BC6	BC5	BC4	BC3	BC2	BC1	BC0	xxxxxxx	RW	
E692	2	reserved												
E694	1	EP4BCH see Section 15.15	Endpoint 4 Byte Count H	0	0	0	0	0	0	BC9	BC8	000000xxx	RW	
E695	1	EP4BCL see Section 15.15	Endpoint 4 Byte Count L	BC7/SKIP	BC6	BC5	BC4	BC3	BC2	BC1	BC0	xxxxxxx	RW	
E696	2	reserved												
E698	1	EP6BCH see Section 15.15	Endpoint 6 Byte Count H	0	0	0	0	0	BC10	BC9	BC8	00000xxx	RW	
E699	1	EP6BCL see Section 15.15	Endpoint 6 Byte Count L	BC7/SKIP	BC6	BC5	BC4	BC3	BC2	BC1	BC0	xxxxxxx	RW	
E69A	2	reserved												
E69C	1	EP8BCH see Section 15.15	Endpoint 8 Byte Count H	0	0	0	0	0	0	BC9	BC8	000000xxx	RW	
E69D	1	EP8BCL see Section 15.15	Endpoint 8 Byte Count L	BC7/SKIP	BC6	BC5	BC4	BC3	BC2	BC1	BC0	xxxxxxx	RW	
E69E	2	reserved												
E6A0	1	EP0CS	Endpoint 0 Control and Status	HSNAK	0	0	0	0	0	BUSY	STALL	10000000	bbbbbb	
E6A1	1	EP1OUTCS	Endpoint 1 OUT Control and Status	0	0	0	0	0	0	BUSY	STALL	00000000	bbbbbb	
E6A2	1	EP1INCS	Endpoint 1 IN Control and Status	0	0	0	0	0	0	BUSY	STALL	00000000	bbbbbb	
E6A3	1	EP2CS	Endpoint 2 Control and Status	0	NPAK2	NPAK1	NPAK0	FULL	EMPTY	0	STALL	00101000	rrrrrr	NPAK2: 0=number of packets in the FIFO, 0-4.
E6A4	1	EP4CS	Endpoint 4 Control and Status	0	NPAK2	NPAK1	NPAK0	FULL	EMPTY	0	STALL	00101000	rrrrrr	NPAK1: 0=number of packets in the FIFO, 0-2
E6A5	1	EP6CS	Endpoint 6 Control and Status	0	NPAK2	NPAK1	NPAK0	FULL	EMPTY	0	STALL	00000100	rrrrrr	OUT: Packets received from USB. IN: Packets loaded and armed. FULL / EMPTY status bits duplicated in SFR space, EP2468STAT
E6A6	1	EP8CS	Endpoint 8 Control and Status	0	0	NPAK1	NPAK0	FULL	EMPTY	0	STALL	00000100	rrrrrr	OUT: full byte count; IN: bytes in current packet EP2 max 4096 EP4 max 1024 EP6 max 2048 EP max 1024
E6A7	1	EP2FIFOFLGS	Endpoint 2 slave FIFO Flags	0	0	0	0	0	PF	EF	FF	00000010	R	Not affected by FIFOINPOLAR bits duplicated in SFR space, EP24FIFOFLGS and EP68FIFOFLGS
E6A8	1	EP4FIFOFLGS	Endpoint 4 slave FIFO Flags	0	0	0	0	0	PF	EF	FF	00000010	R	
E6A9	1	EP6FIFOFLGS	Endpoint 6 slave FIFO Flags	0	0	0	0	0	PF	EF	FF	00000110	R	
E6AA	1	EP8FIFOFLGS	Endpoint 8 slave FIFO Flags	0	0	0	0	0	PF	EF	FF	00000110	R	
E6AB	1	EP2FIOBCH	Endpoint 2 slave FIFO total byte count H	0	0	0	BC12	BC11	BC10	BC9	BC8	00000000	R	
E6AC	1	EP2FIOBCL	Endpoint 2 slave FIFO total byte count L	BC7	BC6	BC5	BC4	BC3	BC2	BC1	BC0	00000000	R	
E6AD	1	EP4FIOBCH	Endpoint 4 slave FIFO total byte count H	0	0	0	0	0	BC10	BC9	BC8	00000000	R	
E6AE	1	EP4FIOBCL	Endpoint 4 slave FIFO total byte count L	BC7	BC6	BC5	BC4	BC3	BC2	BC1	BC0	00000000	R	
E6AF	1	EP6FIOBCH	Endpoint 6 slave FIFO total byte count H	0	0	0	0	0	BC10	BC9	BC8	00000000	R	
E6B0	1	EP6FIOBCL	Endpoint 6 slave FIFO total byte count L	BC7	BC6	BC5	BC4	BC3	BC2	BC1	BC0	00000000	R	
E6B1	1	EP8FIOBCH	Endpoint 8 slave FIFO total byte count H	0	0	0	0	0	BC10	BC9	BC8	00000000	R	
E6B2	1	EP8FIOBCL	Endpoint 8 slave FIFO total byte count L	BC7	BC6	BC5	BC4	BC3	BC2	BC1	BC0	00000000	R	
E6B3	1	SUDPTRH	Setup Data Pointer high address byte	A15	A14	A13	A12	A11	A10	A9	A8	xxxxxxx	RW	Must be word-aligned (i.e., must point to even-numbered address- es)
E6B4	1	SUDPTRL	Setup Data Pointer low address byte	A7	A6	A5	A4	A3	A2	A1	0	xxxxxxx0	bbbbbb	
E6B5	1	SUDPTRCTL	Setup Data Pointer Auto Mode	0	0	0	0	0	0	0	SDPAUTO	00000001	RW	Clear b0 to supply SUDPTR length (override USB length)
E6B6	2	reserved												
E6B8	8	SETUPDAT	8 bytes of SETUP data	D7	D6	D5	D4	D3	D2	D1	D0	xxxxxxx	R	



Table C-1. EZ-USB® Registers and Buffers (continued)

Hex	Size	Name	Description	b7	b6	b5	b4	b3	b2	b1	b0	Default	Access	Notes
			SETUPDAT[0] = bmRequestType											D7: Data Transfer Direction; 0=host-to-device, 1=device-to-host D6...5 Type; 0=standard, 1=class, 2=vendor, 3=reserved D4...0 Recipient; 0=device, 1=interface, 2=endpoint, 3=other, 4...31=reserved
			SETUPDAT[1] = bmRequest											Specific request
			SETUPDAT[2:3] = wValue											Word-sized field that varies according to request
			SETUPDAT[4:5] = wIndex											Word-sized field that varies according to request; typically used to pass an index or offset
			SETUPDAT[6:7] = wLength											Number of bytes to transfer if there is a data stage
		GPIF												
E6C0	1	GPWFSELECT	Waveform Selector	SINGLEWR1	SINGLEWR0	SINGLERD1	SINGLERD0	FIFOWR1	FIFOWR0	FIFORD1	FIFORD0	11100100	RW	Select waveform
E6C1	1	GPFIIDLECS	GPIF Done, GPIF IDLE drive mode	DONE	0	0	0	0	0	0	IDLEDRV	10000000	RW	DONE=1: GPIF done (RC04). IDLEDRV=1: drive bus; 0:TS
E6C2	1	GPFIIDLECTL	Inactive Bus, CTL states	0	0	CTL5	CTL4	CTL3	CTL2	CTL1	CTL0	11111111	RW	DONE duplicated in SFR space, GPIFTRIG bit 7
E6C3	1	GPIFCTLCFG	CTL Drive Type	TRICTL	0	CTL5	CTL4	CTL3	CTL2	CTL1	CTL0	00000000	RW	0=CMOS, 1=open drn.
E6C4	1	GPIFADRH	GPIF Address H	0	0	0	0	0	0	0	GPIFA8	00000000	RW	GPIFADRH/L active immediately when written to
E6C5	1	GPIFADRL	GPIF Address L	GPIFA7	GPIFA6	GPIFA5	GPIFA4	GPIFA3	GPIFA2	GPIFA1	GPIFA0	00000000	RW	
		FLOWSTATE												
E6C6	1	FLOWSTATE	Flowstate Enable and Selector	FSE	0	0	0	0	FS2	FS1	FS0	00000000	rrrrbbb	
E6C7	1	FLOWLOGIC	Flowstate Logic	LFUNC1	LFUNCO	TERMA2	TERMA1	TERMA0	TERMB2	TERMB1	TERMB0	00000000	RW	
E6C8	1	FLOWEQ0CTL	CTL Pin States in Flowstate (when Logic = 0)	CTL0E3	CTL0E2	CTL0E1/CTL5	CTL0E0/CTL4	CTL3	CTL2	CTL1	CTL0	00000000	RW	
E6C9	1	FLOWEQ1CTL	CTL Pin States in Flowstate (when Logic = 1)	CTL0E3	CTL0E2	CTL0E1/CTL5	CTL0E0/CTL4	CTL3	CTL2	CTL1	CTL0	00000000	RW	
E6CA	1	FLOWHOLDOFF	Holdoff Configuration	HOPERIOD3	HOPERIOD2	HOPERIOD1	HOPERIOD0	HOSTATE	HOCTL2	HOCTL1	HOCTL0	00010010	RW	
E6CB	1	FLOWSTB	Flowstate Strobe Configuration	SLAVE	RDYASYN	CTLTOGL	SUSTAIN	0	MSTB2	MSTB1	MSTB0	00100000	RW	
E6CC	1	FLOWSTBEDGE	Flowstate Rising/Falling Edge Configuration	0	0	0	0	0	0	FALLING	RISSING	00000001	rrrrrbb	
E6CD	1	FLOWSTBPERIOD	Master-Strobe Half-Period	D7	D6	D5	D4	D3	D2	D1	D0	00000010	RW	In units of IFCLK/2. Must be >= 2
E6CE	1	GPIFTCB3	GPIF Transaction Count Byte 3	TC31	TC30	TC29	TC28	TC27	TC26	TC25	TC24	00000000	RW	Reading these registers give you the live Transaction Count. Default=1
E6CF	1	GPIFTCB2	GPIF Transaction Count Byte 2	TC23	TC22	TC21	TC20	TC19	TC18	TC17	TC16	00000000	RW	
E6D0	1	GPIFTCB1	GPIF Transaction Count Byte 1	TC15	TC14	TC13	TC12	TC11	TC10	TC9	TC8	00000000	RW	
E6D1	1	GPIFTCB0	GPIF Transaction Count Byte 0	TC7	TC6	TC5	TC4	TC3	TC2	TC1	TC0	00000001	RW	
	2	reserved										00000000	RW	
		reserved												
E6D2	1	EP2GPIFFLGSEL	Endpoint 2 GPIF Flag select	0	0	0	0	0	0	FS1	FS0	00000000	RW	00: Programmable flag; 01: Empty; 10: Full; 11: reserved
E6D3	1	EP2GPIFPFSSTOP	Endpoint 2 GPIF stop transaction on program flag	0	0	0	0	0	0	0	FIFO2FLAG	00000000	RW	1=override TC value, stop on FIFO Prog. Flag.
E6D4	1	EP2GPIFTRIG	Endpoint 2 GPIF Trigger	x	x	x	x	x	x	x	x	xxxxxxx	W	Start GPIF transactions, duplicated in SFR - GPIFTRIG
	3	reserved												
		reserved												
		reserved												



Table C-1. EZ-USB® Registers and Buffers (continued)

Hex	Size	Name	Description	b7	b6	b5	b4	b3	b2	b1	b0	Default	Access	Notes
E6DA	1	EP4GPIFLAGSEL see Section 15.15	Endpoint 4 GPIF Flag select	0	0	0	0	0	0	FS1	FS0	00000000	RW	00: Programmable level; 01: Empty, 10: Full, 11: reserved
E6DB	1	EP4GPIPFSTOP	Endpoint 4 GPIF stop transaction on GPIF Flag	0	0	0	0	0	0	0	FIFO4FLAG	00000000	RW	
E6DC	1	EP4GPIFTRIG see Section 15.15	Endpoint 4 GPIF Trigger	x	x	x	x	x	x	x	x	xxxxxxx	W	Start GPIF transactions, duplicated in SFR - GPIFTRIG
	3	reserved												
		reserved												
E6E2	1	EP6GPIFLAGSEL see Section 15.15	Endpoint 6 GPIF Flag select	0	0	0	0	0	0	FS1	FS0	00000000	RW	00: Programmable flag; 01: Empty, 10: Full, 11: reserved (PF)
E6E3	1	EP6GPIPFSTOP	Endpoint 6 GPIF stop transaction on prog. flag	0	0	0	0	0	0	0	FIFO6FLAG	00000000	RW	
E6E4	1	EP6GPIFTRIG see Section 15.15	Endpoint 6 GPIF Trigger	x	x	x	x	x	x	x	x	xxxxxxx	W	Start GPIF transactions, duplicated in SFR - GPIFTRIG
	3	reserved												
		reserved												
E6EA	1	EP8GPIFLAGSEL see Section 15.15	Endpoint 8 GPIF Flag select	0	0	0	0	0	0	FS1	FS0	00000000	RW	00: Programmable flag; 01: Empty, 10: Full, 11: Reserved (PF)
E6EB	1	EP8GPIPFSTOP	Endpoint 8 GPIF stop transaction on prog. flag	0	0	0	0	0	0	0	FIFO8FLAG	00000000	RW	
E6EC	1	EP8GPIFTRIG see Section 15.15	Endpoint 8 GPIF Trigger	x	x	x	x	x	x	x	x	xxxxxxx	W	Start GPIF transactions, duplicated in SFR - GPIFTRIG
	3	reserved												
E6F0	1	XGPIFSGLDATH	GPIF Data H (16-bit mode only)	D15	D14	D13	D12	D11	D10	D9	D8	xxxxxxx	RW	Duplicated in SFR space, SGLDATH / SGLDATHLX / SGLDATHLNOX
E6F1	1	XGPIFSGLDATLX	Read/Write GPIF Data L and trigger transaction	D7	D6	D5	D4	D3	D2	D1	D0	xxxxxxx	RW	8051read or write triggers GPIF transaction
E6F2	1	XGPIFSGLDATLNOX	Read GPIF Data L, no transaction trigger	D7	D6	D5	D4	D3	D2	D1	D0	xxxxxxx	R	8051 reads data w/o GPIF transaction trig. (e.g. last byte)
E6F3	1	GPIFREADYCFG	Internal RDY, Sync/Async, RDY pin states	INTRDY	SAS	TCXRDY5	0	0	0	0	0	00000000	bbbbrrrr	INTRDY is 8051 'Ready', like RDYn pins. RDYn indicate pin states
														SAS =1: synchronous, 0: asynchronous (2-flops) RDYn inputs
E6F4	1	GPIFREADYSTAT	GPIF Ready Status	0	0	RDY5	RDY4	RDY3	RDY2	RDY1	RDY0	00xxxxxx	R	RDYn indicate pin states
E6F5	1	GPIFABORT	Abort GPIF Waveforms	x	x	x	x	x	x	x	x	xxxxxxx	W	Go To GPIF IDLE state. Data is don't care
	2	reserved												
		ENDPOINT BUFFERS												
E740	64	EP0BUF	EP0-IN/-OUT buffer	D7	D6	D5	D4	D3	D2	D1	D0	xxxxxxx	RW	
E780	64	EP1OUTBUF	EP1-OUT buffer	D7	D6	D5	D4	D3	D2	D1	D0	xxxxxxx	RW	
E7C0	64	EP1INBUF	EP1-IN buffer	D7	D6	D5	D4	D3	D2	D1	D0	xxxxxxx	RW	
	2048	reserved												
F000	1024	EP2FIFOBUF	512/1024-byte EP 2 / slave FIFO buffer (IN or OUT)	D7	D6	D5	D4	D3	D2	D1	D0	xxxxxxx	RW	For 512 use only 0xF000-0xF1FF
F400	512	EP4FIFOBUF	512 byte EP 4 / slave FIFO buffer (IN or OUT)	D7	D6	D5	D4	D3	D2	D1	D0	xxxxxxx	RW	
	512	reserved												
F800	1024	EP6FIFOBUF	512/1024-byte EP 6 / slave FIFO buffer (IN or OUT)	D7	D6	D5	D4	D3	D2	D1	D0	xxxxxxx	RW	For 512 use only 0xF800-0xF9FF



Device Register Summary

Table C-1. EZ-USB® Registers and Buffers (continued)

Hex	Size	Name	Description	b7	b6	b5	b4	b3	b2	b1	b0	Default	Access	Notes
FC00	512	EP8FIFOBUF	512 byte EP 8 / slave FIFO buffer (IN or OUT)	D7	D6	D5	D4	D3	D2	D1	D0	xxxxxxx	RW	
FE00	512	reserved												
xxxx		FC Compatible Configuration Byte												
				0	DISCON	0	0	0	0	0	400KHZ	xxxxxxx 00000000 if no EPROM detected	n/a	DISCON = copied into DISCON bit (USBCS.3) for power-on USB connect state 400KHZ = 1 for 400 KHz I2C compatible bus operation Note: If no EEPROM is connected all bits default to register default values.
Special Function Registers (SFRs)														
80	1	IOA ⁽¹⁾	Port A (bit addressable)	D7	D6	D5	D4	D3	D2	D1	D0	xxxxxxx	RW	
81	1	SP	Stack Pointer	D7	D6	D5	D4	D3	D2	D1	D0	0000111	RW	
82	1	DPLO	Data Pointer 0 L	A7	A6	A5	A4	A3	A2	A1	A0	00000000	RW	
83	1	DPHO	Data Pointer 0 H	A15	A14	A13	A12	A11	A10	A9	A8	00000000	RW	
84	1	DPL1 ⁽¹⁾	Data Pointer 1 L	A7	A6	A5	A4	A3	A2	A1	A0	00000000	RW	
85	1	DPH1 ⁽¹⁾	Data Pointer 1 H	A15	A14	A13	A12	A11	A10	A9	A8	00000000	RW	
86	1	DPS ⁽¹⁾	Data Pointer 0/1 select	0	0	0	0	0	0	0	SELE	00000000	RW	
87	1	PCON	Power Control	SMOD0	x	1	1	x	x	x	IDLE	00110000	RW	
88	1	TCON	Timer/Counter Control (bit addressable)	TF1	TR1	TF0	TR0	IE1	IT1	IE0	IT0	00000000	RW	
89	1	TMOD	Timer/Counter Mode Control	GATE	CT	M1	M0	GATE	CT	M1	M0	00000000	RW	
8A	1	TL0	Timer 0 reload L	D7	D6	D5	D4	D3	D2	D1	D0	00000000	RW	
8B	1	TL1	Timer 1 reload L	D7	D6	D5	D4	D3	D2	D1	D0	00000000	RW	
8C	1	TH0	Timer 0 reload H	D15	D14	D13	D12	D11	D10	D9	D8	00000000	RW	
8D	1	TH1	Timer 1 reload H	D15	D14	D13	D12	D11	D10	D9	D8	00000000	RW	
8E	1	CKCON ⁽¹⁾	Clock Control	x	x	T2M	T1M	T0M	MD2	MD1	MD0	00000001	RW	MOVX = 3 instr. cycles (default)
8F	1	reserved												
90	1	IOB ⁽¹⁾	Port B (bit addressable)	D7	D6	D5	D4	D3	D2	D1	D0	xxxxxxx	RW	
91	1	EXIF ⁽¹⁾	External Interrupt Flags	IE5	IE4	FCINT	USBNT	1	0	0	0	00010000	RW	
92	1	MPAGE ⁽¹⁾	Upper Addr. Byte of MOVX using @R0 / @R1	A15	A14	A13	A12	A11	A10	A9	A8	00000000	RW	Used with the indirect addressing instructions, i.e. MOVX @R0,A where MPAGE = upper addr byte and R0 contains lower addr byte an app. example would be to copy EP1 out/in data to a buffer
93	5	reserved												
98	1	SCON0	Serial Port 0 Control (bit addressable)	SM0_0	SM1_0	SM2_0	REN_0	TB8_0	RB8_0	TL_0	RL_0	00000000	RW	
99	1	SBUF0	Serial Port 0 Data Buffer	D7	D6	D5	D4	D3	D2	D1	D0	00000000	RW	
9A	1	AUTOPTRH1 ⁽¹⁾	Autopointer 1 Address H	A15	A14	A13	A12	A11	A10	A9	A8	00000000	RW	
9B	1	AUTOPTL1 ⁽¹⁾	Autopointer 1 Address L	A7	A6	A5	A4	A3	A2	A1	A0	00000000	RW	
9C	1	reserved												
9D	1	AUTOPTRH2 ⁽¹⁾	Autopointer 2 Address H	A15	A14	A13	A12	A11	A10	A9	A8	00000000	RW	
9E	1	AUTOPTL2 ⁽¹⁾	Autopointer 2 Address L	A7	A6	A5	A4	A3	A2	A1	A0	00000000	RW	



Table C-1. EZ-USB® Registers and Buffers (continued)

Hex	Size	Name	Description	b7	b6	b5	b4	b3	b2	b1	b0	Default	Access	Notes
9F	1	reserved												
A0	1	IOC ⁽¹⁾	Port C (bit addressable)	D7	D6	D5	D4	D3	D2	D1	D0	xxxxxxx	RW	
A1	1	INT2CLR ⁽¹⁾	Interrupt 2 clear	x	x	x	x	x	x	x	x	xxxxxxxx	W	
A2	1	INT4CLR ⁽¹⁾	Interrupt 4 clear	x	x	x	x	x	x	x	x	xxxxxxxx	W	
A3	5	reserved												
A8	1	IE	Interrupt Enable (bit addressable)	EA	ES1	ET2	ES0	ET1	EX1	ET0	EX0	00000000	RW	
A9	1	reserved												
AA	1	EP2468STAT ⁽¹⁾	Endpoint 2,4,6,8 status flags	EP8F	EP8E	EP6F	EP6E	EP4F	EP4E	EP2F	EP2E	01011010	R	Check Empty/Full status of EP 2,4,6,8 using MOV
AB	1	EP24FIFOFLGS ⁽¹⁾	Endpoint 2,4 slave FIFO status flags	0	EP4PF	EP4EF	EP4FF	0	EP2PF	EP2EF	EP2FF	00100010	R	Check Prg/Empty/Full status of EP 2,4 slave FIFO using MOV instr
AC	1	EP68FIFOFLGS ⁽¹⁾	Endpoint 6,8 slave FIFO status flags	0	EP8PF	EP8EF	EP8FF	0	EP6PF	EP6EF	EP6FF	01100110	R	Check Prg/Empty/Full status of EP 6,8 slave FIFO using MOV instr.
AD	2	reserved												
AF	1	AUTOPTRESETUP ⁽¹⁾	Autopointer 1 and 2 Setup	0	0	0	0	0	APTR2INC	APTR1INC	APTREN	00000110	RW	APTRXINC=1 inc autopointers; AP-TRXINC=0 freeze autopointers APTREN=1 RDWR strobes asserted when using MOVX version
B0	1	IOD ⁽¹⁾	Port D (bit addressable)	D7	D6	D5	D4	D3	D2	D1	D0	xxxxxxx	RW	
B1	1	IOE ⁽¹⁾	Port E (NOT bit addressable)	D7	D6	D5	D4	D3	D2	D1	D0	xxxxxxx	RW	
B2	1	OEAI ⁽¹⁾	Port A Output Enable	D7	D6	D5	D4	D3	D2	D1	D0	00000000	RW	
B3	1	OEB ⁽¹⁾	Port B Output Enable	D7	D6	D5	D4	D3	D2	D1	D0	00000000	RW	
B4	1	OEC ⁽¹⁾	Port C Output Enable	D7	D6	D5	D4	D3	D2	D1	D0	00000000	RW	
B5	1	OED ⁽¹⁾	Port D Output Enable	D7	D6	D5	D4	D3	D2	D1	D0	00000000	RW	
B6	1	OEE ⁽¹⁾	Port E Output Enable	D7	D6	D5	D4	D3	D2	D1	D0	00000000	RW	
B7	1	reserved												
B8	1	IP	Interrupt Priority (bit addressable)	1	PS1	PT2	PS0	PT1	PX1	PT0	PX0	10000000	RW	
B9	1	reserved												
BA	1	EP01STAT ⁽¹⁾	Endpoint 0 and 1 Status	0	0	0	0	0	EP1INBSY	EP1OUTBSY	EP0BSY	00000000	R	Check EP0 and EP1 status using MOV instruction
BB	1	GPIFTRIG ⁽¹⁾ see Section 15.15	Endpoint 2,4,6,8 GPIF slave FIFO Trigger	DONE	0	0	0	0	RW	EP1	EP0	10000xxx	rrrrrrbb	RW=1 reads, RW=0 writes; EP1[0] = 00 EP2, = 01 EP4, = 10 EP6, = 11 EP8
BC	1	reserved												
BD	1	GPFSGLDATH ⁽¹⁾	GPIF Data H (16-bit mode only)	D15	D14	D13	D12	D11	D10	D9	D8	xxxxxxx	RW	Efficient versions of their MOVX buddies
BE	1	GPFSGLDATLX ⁽¹⁾	GPIF Data L w/ Trigger	D7	D6	D5	D4	D3	D2	D1	D0	xxxxxxx	RW	
BF	1	GPFSGLDNLNOX ⁽¹⁾	GPIF Data L w/ No Trigger	D7	D6	D5	D4	D3	D2	D1	D0	xxxxxxx	R	Note: READ only, this should help you decide when to appropriately use it
C0	1	SCON1 ⁽¹⁾	Serial Port 1 Control (bit addressable)	SM0_1	SM1_1	SM2_1	REN_1	TB8_1	RB8_1	TL_1	RL_1	00000000	RW	
C1	1	SBUF1 ⁽¹⁾	Serial Port 1 Data Buffer	D7	D6	D5	D4	D3	D2	D1	D0	00000000	RW	
C2	6	reserved												
C8	1	TZCON	Timer/Counter 2 Control (bit addressable)	TF2	EXF2	RCLK	TCLK	EXEN2	TR2	CT2	CPRL2	00000000	RW	
C9	1	reserved												
CA	1	RCAP2L	Capture for Timer 2, auto-reload, up-counter	D7	D6	D5	D4	D3	D2	D1	D0	00000000	RW	
CB	1	RCAP2H	Capture for Timer 2, auto-reload, up-counter	D7	D6	D5	D4	D3	D2	D1	D0	00000000	RW	
CC	1	TL2	Timer 2 reload L	D7	D6	D5	D4	D3	D2	D1	D0	00000000	RW	
CD	1	TH2	Timer 2 reload H	D15	D14	D13	D12	D11	D10	D9	D8	00000000	RW	
CE	2	reserved												



Device Register Summary

Table C-1. EZ-USB® Registers and Buffers (continued)

Hex	Size	Name	Description	b7	b6	b5	b4	b3	b2	b1	b0	Default	Access	Notes
D0	1	P SW	Program Status Word (bit addressable)	CY	AC	F0	RS1	RS0	OV	F1	P	00000000	RW	
D1	7	reserved												
D8	1	EICON ⁽¹⁾	External Interrupt Control	SMOD1	1	ERES1	RES1	INT6	0	0	0	01000000	RW	RES1 - reflects D+ / WU / WU2 src while SUSPEND (PCON.1); clocks off
D9	7	reserved												
E0	1	ACC	Accumulator (bit addressable)	D7	D6	D5	D4	D3	D2	D1	D0	00000000	RW	
E1	7	reserved												
E8	1	EIE ⁽¹⁾	External Interrupt Enables	1	1	1	EX6	EX5	EX4	E1°C	EUSB	11100000	RW	
E9	7	reserved												
F0	1	B	B (bit addressable)	D7	D6	D5	D4	D3	D2	D1	D0	00000000	RW	
F1	7	reserved												
F8	1	EIP ⁽¹⁾	External Interrupt Priority Control	1	1	1	PX6	PX5	PX4	P1°C	PUSB	11100000	RW	
F9	7	reserved												

⁽¹⁾ SFRs not part of the standard 8051 architecture.

Index



#

- 100 pin package 22
- 128 pin package 22, 23
- 230 Kbaud clock register 228
- 56 pin SSOP 22
- 56 pin VFBGA 22
- 803x/805x feature comparison 171
- 8051 enhancements 170

A

- abort GPIF cycles register 358
- aborting packets in FIFO 120
- ACC register 179
- access to endpoint data 89
- access to IN packets 116
- accessible memory spaces 96
- accumulator 179
- addressing an I2C peripheral 189
- asynchronous FIFO IN data transfers 119
- asynchronous FIFO reads 109, 110
- asynchronous FIFO writes 108, 109
- asynchronous mode 100
- auto mode 118
- auto-in initialization 117
- auto-in mode 111
- auto-out initialization 117
- auto-out mode 111
- autopointer setup registers 215
- autopointers 96
- AUTOPOINTERS 1 and 2 MOVX access registers 282
- autovector coding 68
- autovectoring 67

B

- B register 179
- block diagram
 - EZ-USB 21
 - simplified package 19
- BPADDRx register 227
- breakpoint address registers 227
- breakpoint control register 226
- BREAKPT register 226
- bulk transfers 16

- burst transactions 150

C

- C0 load format 53
- C2 load format 53
- chip revision control register 231
- chip revision ID register 230
- CKCON register 178, 179, 197
- clear error count register 271
- clear feature 43
- clearing interrupt requests 65
- CLRERRCNT register 271
- code example
 - aborting packets in FIFO in AUTOIN mode 120
 - asynchronous slave FIFO IN data transfers 119
 - AUTOIN = 1 115
 - AUTOOUT=0, commit packet 113
 - AUTOOUT=0, skip packet 114
 - AUTOOUT=0, source 114
 - committing a packet via INPKTEND 116
 - committing an OUT packet 165
 - committing packets via EPxBCL 156
 - committing packets via INPKTEND 155
 - committing packets via OUTPKTEND 163
 - configuring AUTOIN 112
 - configuring AUTOOUT 112, 113
 - configuring AUTOOUT = 1 164
 - ECC check/correct 284
 - editing a packet via EPxBCH 117
 - FIFO-read transaction code 156
 - FIFO-read transaction functions 154
 - FIFO-write transaction code 164
 - FIFO-write transaction functions 162
 - GPIF framework and functions 137
 - initialization code for AUTOOUT=0 165
 - initialization code for single-read 146
 - initialization code for single-write transactions 149
 - initialization for FIFO read transactions 155
 - initialization for FIFO-write transactions 163
 - OUT endpoint initialization 114
 - single-read transaction functions 145
 - single-write transaction functions 149
 - skipping a packet via INPKTEND 117
 - skipping an OUT packet 166
 - skipping out packets in AUTOOUT mode 119
 - sourcing an IN packet 116, 158
 - sourcing an OUT packet 166
 - synchronous slave FIFO IN data transfer 118
 - writing INPKTEND with EPx number 157

- compatibility
 - feature-by-feature 171
- configuration descriptor
 - high speed 376
- control of endpoints 89
- control transfers 16
- CPU access to IN packets 115
- CPU access to OUT packets 112
- CPU control and status register 220
- CPU reset 84
- CPU reset effects 84
- CPUCS register 220
- CTL output drive type register 336
- CTL output in idle register 335
- CTL output states in idle 335
- CY7C68013A and CY7C68015A differences 22

D

- data memory 76
- data pointers 179
- data toggle control register 300
- default USB device 52
- default USB device respond 56
- descriptors for high speed mode 375
- device descriptor
 - full speed 367
 - high speed 375
- device qualifier
 - full speed 368
 - high speed 375
- document history 35
- DPH0 register 179
- DPH1 register 179
- DPL0 register 179
- DPL1 register 179
- DPS register 179
- DPTR0 179
- DPTR1 179

E

- ECC
 - See error correcting codes
- ECC check/correct code example 284
- ECC configuration register 287
- ECC control and data registers 283–294
- ECC generation 167
- ECC reset register 288
- ECC1B0 register 289
- ECC1B1 register 290
- ECC1B2 register 291
- ECC2B0 register 292
- ECC2B1 register 293
- ECC2B2 register 294
- ECCCFG register 287
- ECCRESET register 288
- EEPROM boot loader 192

- EEPROM boot-load data format 52
- EEPROM configuration byte 55
- eight bytes of setup data 332
- endpoint 'x'/slave FIFO programmable-level flag registers 244, 246, 247
- endpoint 0 registers 305, 306
- endpoint 1 IN byte count register 308
- endpoint 1 OUT byte count register 307
- endpoint 2 byte count registers 309, 313
- endpoint 4 byte count registers 311, 313
- endpoint 6 byte count registers 310, 313
- endpoint 8 byte count registers 312, 313
- endpoint buffer registers 359–365
- endpoint buffers
 - access to 87
 - how the CPU configures 88
 - large and small 87
- endpoint configuration registers 233–255
- endpoint descriptor
 - full speed 369, 370, 371, 372, 373, 374
 - high speed 377, 378, 379, 380, 381
- endpoint registers 305–332
- endpoint x AUTOIN packet length registers 239, 240, 241, 242, 243
- endpoint x configuration registers 235
- endpoint x control and status registers 314, 315, 316, 317, 318, 319, 320
- endpoint x GPIF flag select registers 350
- endpoint x GPIF stop transaction registers 351
- endpoint x ISO IN packets per Frame 251, 252, 253
- endpoint x ISO IN packets per frame register 250
- endpoint x slave FIFO flags registers 321, 322, 323, 324
- endpoint x slave FIFO GPIF trigger registers 352
- endpoint x slave FIFO total byte count registers 325, 326, 327, 328, 329
- endpoint zero 37
- endpoint/slave FIFO configuration registers 237
- endpoints 89
 - EP0BCH 90
 - EP0BCL 90
 - IN 248
 - OUT 249
- enter suspend state register 298
- enumeration 16
- enumeration and ReNumeration 51
- EP01STAT 91
- EP0BCH register 305
- EP0BCL register 306
- EP0BUF register 359
- EP0CS 90
- EP0CS register 314
- EP1INBC 92
- EP1INBC register 308
- EP1INBUF register 361
- EP1INCFG register 234
- EP1INCS 91
- EP1INCS register 316
- EP1OUTBC 91

EP1OUTBC register 307
 EP1OUTBUF register 360
 EP1OUTCFG register 233
 EP1OUTCS 91
 EP1OUTCS register 315
 EP2468STAT 92
 EP2AUTOINLENH registers 239
 EP2BCH register 309
 EP2CS register 317
 EP2FIFOBCH register 325
 EP2FIFOBUF register 362
 EP2FIFOFLGS register 321
 EP2ISOINPKTS register 250
 EP4AUTOINLENH register 241
 EP4BCH register 311
 EP4CS register 318
 EP4FIFOBCH register 327
 EP4FIFOBUF register 363
 EP4FIFOFLGS register 322
 EP4ISOINPKTS register 251
 EP6AUTOINLENH register 240
 EP6BCH register 310
 EP6CS register 319
 EP6FIFOBCH register 326
 EP6FIFOBUF register 364
 EP6FIFOFLGS register 323
 EP6ISOINPKTS register 252
 EP8AUTOINLENH register 242
 EP8BCH register 312
 EP8CS register 320
 EP8FIFOBCH register 328
 EP8FIFOBUF register 365
 EP8FIFOFLGS register 324
 EP8ISOINPKTS register 253
 EPIE register 264
 EPIRQ register 265
 EPx memories 111
 EPxAUTOINLENL registers 243
 EPxBCH low 93
 EPxBCL registers 313
 EPxCFG registers 235
 EPxCS 92
 EPxFIFOBCL registers 329
 EPxFIFOCFG registers 237
 EPxFIFOIE registers 256
 EPxFIFOIRQ registers 257
 EPxFIFOPFH registers 244
 EPxFIFOPFL registers 247
 EPxGPIFFLGSEL registers 350
 EPxGPIFPFSTOP registers 351
 EPxGPIFTRIG registers 352
 EPxISOINPKTS 92
 ERRCNTLIM register 270
 error correcting codes 283
 external data memory 71, 72
 external FIFO interface 31
 external program memory 71, 72
 external program/data memory map 75

EZ-USB
 and DS80C320 differences 172
 architecture 18
 block diagram 21
 CPU 169
 differences with DS80C320 interrupts 172
 endpoint buffers 30
 endpoint FIFOs signals 23
 feature summary 20
 input output systems 181
 instruction set 176
 integrated microprocessor 20
 internal RAM 172
 IO ports 173
 low-power mode implementation 173
 package types 22
 package types signal names 24
 performance overview 170
 register interface 172
 registers 211
 registers and buffers summary 384
 software compatibility with 8051 171
 supported interrupts 173
 EZ-USB chips
 100 pin 73
 128 pin 73
 56 pin 73
 EZ-USB CPU Features 169
 EZ-USB FIFOs
 in GPIF master mode 33
 in slave FIFO mode 32
 EZ-USB FX1
 part numbers 34
 EZ-USB FX2LP
 package diagrams 25
 part numbers 34

F

FIFO
 maximum sizes 249
 FIFO cleared after a hard reset 167
 FIFO data bus 101
 FIFO flag pin functions 223
 FIFO flag pins 103
 FIFO programmable-level flag 111
 FIFO reset register 225
 FIFO/GPIF autovector coding 70
 FIFO/GPIF interrupt 69
 FIFOINPOLAR register 229
 FIFO-read transaction 151
 FIFO-read transaction waveform 152
 FIFORESET register 225
 FIFO-write transaction 159
 firmware access to IN packets 156, 157
 firmware access to OUT packets 164, 165
 firmware FIFO access 110
 firmware load 56
 firmware ReNumeration 57
 FLAGx pins 103

FLOWEQxCTL registers 342
 FLOWHOLDOFF register 345
 FLOWLOGIC register 341
 FLOWSTATE register 340
 FLOWSTB register 344
 FLOWSTBEDGE register 346
 FLOWSTBHPERIOD register 347
 FNADDR register 304
 force IN packet end register 254
 force OUT packet end register 255

G

general configuration registers 220–232
 general programmable interface (GPIF) 121
 get configuration 47
 get descriptor 43
 get interface 48
 get status interface 42
 Get_Descriptor requests 44
 Get_Status request 41
 GPIF
 8/16-bit data path 125
 address OUT signals 124
 and the EZ-USB system 122
 byte order for 16-bit transactions 125
 connecting signal pins to hardware 126
 control out signals 124
 decision point (DP) 129, 130
 default pins configuration 124
 example hardware interconnect 126
 external interface 124
 flag selection 150
 flag stop 150
 framework and functions source code 137
 GSTATE OUT signals 124
 IDLE state 128
 interrupt enable register 266
 interrupt request register 267
 non-decision point (NDP) 128
 programming the waveforms 127
 ready IN signals 124
 re-executing a task within a DP state 131
 registers 127, 333–358
 registers associated with firmware 137
 terminating a transfer 136
 transaction waveform 123
 waveform descriptor 219
 GPIF address low 339
 GPIF address registers 338, 339
 GPIF data high (16 bit mode) register 353
 GPIF done and idle drive mode register 334
 GPIF done, GPIF idle drive mode 334
 GPIF flow holdoff register 345
 GPIF flow logic CTL output drive registers 342
 GPIF flow master strobe edge register 346
 GPIF flow master strobe half period register 347
 GPIF flow master strobe register 344
 GPIF flow state logic register 341
 GPIF flow state register 340

GPIF hold amount register 348
 GPIF hold time register 232
 GPIF ready pin configuration register 356
 GPIF ready pin status register 357
 GPIF transaction count byte registers 349
 GPIF waveform memories registers 219
 GPIF waveform selector register 333
 GPIFABORT register 358
 GPIFADRH register 338
 GPIFADRL register 339
 GPIFCTLCFG register 336
 GPIFHOLDAMOUNT register 232, 348
 GPIFIDLECS register 334
 GPIFIDLECTL register 335
 GPIFIE register 266
 GPIFIRQ register 267
 GPIFREADYCFG register 356
 GPIFREADYSTAT register 357
 GPIFTCBx registers 349
 GPIFWFSELECT register 333

H

hard reset 83
 high speed and full speed differences 87

I

I/O PORTA alternate configuration register 275
 I/O PORTC alternate configuration register 276
 I/O PORTE alternate configuration register 277
 I/O ports 181
 I2C bus
 control and status register 278
 control register 281
 data register 280
 interrupt 68
 I2C bus controller 189
 I2C bus usage 54
 I2C registers 191
 I2CDAT register 280
 I2CS register 278
 I2CTL register 281
 IBNIE register 258
 IBNIRQ register 259
 IFCFG selection of port IO pin functions 188
 IFCLK configuration 102
 IFCONFIG register 221
 initialization, auto-in/auto-out 117
 INPKTEND register 254
 input/output registers 275–282
 instruction cycle 178
 instruction set 175
 instruction timing 178
 INT 2 (USB) autovector register 272
 INT 2 and INT 4 setup register 274

- INT 4 (slave FIFOs and GPIF) autovector register 273
- int0_n 63, 194
- int1_n 63, 194
- INT2IVEC register 272
- int4 63
- INT4IVEC register 273
- int5_n 63
- interface clock 102
- interface clock (IFCLK) 125
- interface configuration register 221
- interface descriptor
 - full speed 370, 372
 - high speed 376, 378, 380
- interface modes 23
- interface pins polarity register 229
- interfacing to I2C peripherals 189
- internal data memory 71
- internal data RAM 71
 - lower 128 72
 - special function register 72
 - upper 128 72
- interrupt
 - compatibility 61
 - enabling 62
 - latency 63
 - masking 62
 - priorities 62
 - processing 62
 - sampling 62
 - service routine 62
 - transfers 16
 - wakeup 81
- interrupt enable registers
 - endpoint 264
 - endpoint ping-NAK/IBN 260
 - endpoint x slave FIFO flag 256
 - GPIF 266
 - IN-BULK-NAK 258
 - USB 262
 - USB error 268
- interrupt registers 256–274
- interrupt request registers
 - endpoint 265
 - endpoint ping-NAK/IBN 261
 - endpoint x slave FIFO flag 257
 - GPIF 267
 - IN-BULK-NAK 259
 - USB 263
 - USB error 269
- interrupts 59
 - endpoint interrupts 66
 - EPOACK interrupt 66
 - EPxISOERR interrupt 67
 - EPxPING interrupt 67
 - ERRLIMIT interrupt 67
 - FIFO/GPIF 69
 - high speed 66
 - in-bulk-NAK 66
 - start of frame 66
 - SUDAV 66
 - suspend 66

- SUTOK 66
- USB bus reset 66
- introduction to USB 13
- INTSETUP register 274
- IO port alternate functions 183
- isochronous transfers 16

J

- jump instruction and autovectoring 67

M

- memory
 - external data 72
 - external data memory 71
 - external program 72
 - EZ-USB 72
 - internal data RAM 71
 - standard 8051 72
- memory maps 74
- MICROFRAME register 303

N

- NAKIE register 260
- NAKIRQ register 261
- non-decision point state instruction 134

O

- off chip program memory 76
- on chip data memory 76
- OUTPKTEND register 255

P

- pin assignment
 - 100 pin TQFP 26
 - 128 pin TQFP 25
 - 56 pin QFN 28
 - 56 pin SSOP 27
 - 56 pin VFBGA 29
- PINFLAGSxx register 223
- PKTEND 104
- port A alternate functions 185
- port B and port D alternate functions 186
- port C alternate functions 187
- port E alternate functions 188
- PORTACFG register 275
- PORTCCFG register 276
- PORTECFG register 277
- ports, GPIF, slave FIFOs register 221
- power management 77
- program status word 179
- programmable-level flag 111
- PSW register 179, 180

R

RCAP2H register 197
 RCAP2L register 197
 read GPIF data low, no transaction trigger register 355
 read/write GPIF data low and trigger transaction register 354
 receive data 191
 register summary
 endpoint buffers 391
 endpoint configuration 385
 endpoints 388
 flowstate 390
 general configuration 384
 GPIF 390
 GPIF waveform memories 384
 I2C compatible configuration byte 392
 input/output 388
 interrupts 387
 special function registers (SFR) 392
 UDMA 385
 UDMA CRC 388
 USB control 388
 registers
 conventions 211
 endpoint configuration 233–255
 general configuration 220–232
 GPIF waveform memories 219
 special function 212–218
 registers associated with EP0 control transfers 39
 registers that control all endpoints
 CLRERRCNT 94
 EPIE 94
 EPIRQ 94
 ERRCNTLIM 94
 IBNIE 93
 IBNIRQ 93
 NAKIE 93
 TOGCTL 95
 USBERRIE 94
 registers that control EP2, EP4, EP6, and EP8 92
 registers that require a synchronization delay 366
 remote wakeup 81
 RENUM bit 56
 ReNumeration 18
 resets 83
 CPU reset 84
 EZ-USB disconnect 85
 hard reset 83
 summary 85
 USB bus reset 85
 REVCTL register 231
 REVID register 230
 rxd0_in 202, 207
 rxd0_out 202
 rxd1_in 202
 rxd1_out 202

S

SBUF0 register 201
 SBUF1 register 201
 SCON0 register 201
 SCON1 register 201
 send data 191
 serial interface
 description 201
 serial interface engine (SIE) 17
 serial port 0/1
 description 201
 mode 0 202
 mode 1 205
 mode 2 208
 mode 3 210
 modes 201
 set address 48
 set descriptor 46
 set interface 47
 setup data pointer 95
 setup data pointer address registers 330
 setup data pointer AUTO mode register 331
 setup data registers 332
 SETUPDAT registers 332
 SFR registers and external RAM equivalent 218
 single-read transactions 143
 single-write transaction waveform 147
 single-write transactions 147
 skipping a packet 157
 skipping out packets while in AUTOOUT mode 119
 slave FIFO
 chip select (SLCS#) 104
 control pins 103
 firmware 110–120
 hardware 99–110
 pins 100
 slave FIFO's 99, 101
 SOF interrupt 66
 SP register 179
 special function register space 72
 special function registers 59, 174, 212–218
 stack pointer 179
 start of frame Interrupt 66
 startup modes 51
 SUDAV interrupt 66
 SUDPTRCTL register 331
 SUDPTRx registers 330
 summary of interrupt sources 62
 suspend interrupt 66
 SUSPEND register 298
 suspend register 79
 suspend state 298
 suspend-resume control logic 78
 SUTOK interrupt 66
 switching between manual-out and auto-out 120
 sync frame request 49
 synchronization delay 366
 synchronization delay registers 366
 synchronous FIFO IN data transfer 118

synchronous FIFO reads 107
 synchronous FIFO writes 105, 106
 synchronous mode 100

T

t0 194
 t0_out 194
 t1 194
 t1_out 194
 t2 198
 t2_out 198
 T2CON register 197
 t2ex 198
 TCON register 193
 TH0 register 193
 TH1 register 193
 TH2 register 193, 197
 Timer 0/1
 mode 0 194
 mode 1 195
 mode 2 196
 mode 3 196
 modes 193
 rate control 197
 Timer 1
 serial port baud rate generator 205
 Timer 2
 auto-reload mode 199
 baud rate generator mode 200
 capture mode 198
 timer/counter mode 198
 timer/counters 193
 TL0 register 193
 TL1 register 193
 TL2 register 193, 197
 TMOD register 193
 TOGCTL register 300
 tokens and PIDs 14
 transaction counter 150
 transfer length fields 96
 txd0 207
 txd1 202, 207
 typical GPIF interface 123

U

UART230 register 228
 UDMA CRC registers 295–296
 UDMA interface 167
 UDMA qualifier register 296
 UDMA transfers 295
 UDMACRCQUALIFIER register 296
 UDMACRCx register 295
 USB
 about frames 49
 about STALL 42
 bus reset 85

control and status register 57, 297
 control and status register bit definition 297
 control registers 297–304
 control transfer 38
 default configuration descriptor 368
 default device descriptor 367
 default interface 0, alternate setting 0 368
 default interface 0, alternate setting 1 369
 direction 14
 error counter limit register 270
 frame count registers 301, 302
 function address register 304
 interrupt enable register 262
 interrupt request register 263
 interrupt sources 63
 interrupts 64
 microframe count register 303
 requests 39
 resume 81
 specification 14
 suspend 79
 transfer types 15
 USB frame count low 302
 USB frames 15
 USB microframe count 303
 USBCS register 297
 USBERRIE register 268, 269
 USBERRIRQ 94
 USBFRAMEH register 301
 USBFRAMEL register 302
 USBIE 91
 USBIRQ 91
 USB-specific interrupts 63

W

wakeup control and status register 299
 wakeup control register 80
 wakeup interrupt 81
 wakeup/resume sequence 80
 WAKEUPCS register 299
 WAVEDATA register 219
 waveform descriptor structure 136
 WORDWIDE bits 125
 WU2 function 81

X

XAUTODATx register 282
 XGPIFSGLDATH register 353
 XGPIFSGLDATL register 354
 XGPIFSGLDATLNOX register 355

Z

zero length isochronous data packet 250

