

Quick and EZ Guide to USB

Welcome to the world of USB! USB (Universal Serial Bus) promises to solve many of the legacy problems of the past. We've all experienced the frustration when we add a modem, scanner or any other peripheral to our system and it simply didn't work. What's worse, we don't know where to start to find the problem and agonize over having to be on hold for hours at your nearest help line. With major industry support, USB is focused on eliminating these frustrations, making compute systems simpler and easier for the average consumer. USB has such sweeping implications that it will extend past PC platforms and into many household consumer products which have an embedded microprocessor and attachment configuration.

This quick and EZ guide is intended to get you familiar with the basics of USB in 30 minutes. We cover the basics of USB topology, hardware and software issues. We also have pointers on how to you can quickly be up and running with USB traffic in hours using Anchor Chip's innovative architecture. Anchor Chips' focus is to make USB design the EZiest in the market so that the peripheral manufacturer can quickly get to market with a cost effective solution. There is a glossary so that you can talk USB speak.

USB Objectives

USB brings the ultimate in simplicity when connecting peripheral devices. The user no longer needs to determine the right connection for the mouse versus the keyboard.. There isn't a different cable for the monitor, printer or high storage capacity external disk drive. The user never has to determine if the connection is a parallel or serial port. In the world of USB, there are no longer dip switches, jumpers, IRQ conflicts and DMA conflicts. In fact, users will always be able to connect or disconnect a new device when the PC is up and running. Now that's true Plug and Play! Because of this consistency and simplicity for connection, USB will make it easy to add peripheral types that were previously thought to be too difficult for the average user.

A major objective of USB is to ensure it was all encompassing, supporting non-real time data transfer as those used in text, email and graphics as well as time sensitive data such as audio, voice and compressed video. Another major objective of USB is to ensure the implementation was cost effective. While a USB host controller connection will support 12 Mbps serial data rates, a lower rate at 1.5 Mbps was created so that less expensive cables and components could be used. Such low speed devices like mice and keyboards do not require the full 12 Mbps bandwidth. However, such low-speed peripherals benefit greatly from the standardization and ease of use of USB.

USB HARDWARE

USB Bus Topology

The USB bus topology is known as a tiered star topology. The root of the star is the host controller. The USB host is located on the motherboard and normally is integrated into the core logic chip set. There is only ONE host who controls the entire system in a standard USB system. The host controller schedules transactions that are passed back and forth throughout the system to the various peripherals. If the host controller is busy, then all the attached peripherals must wait for the host controller to free itself before further communications can occur.

While a peripheral can be connected directly to the host controller port, it is more likely that a USB hub will be connected to the host controller port to expand the number of peripheral ports available to the user. Hubs permit expansion of a USB system by providing one or more additional USB ports for attaching other USB devices. Peripherals (or another hub) is attached to the hub, creating the star topology. (See Figure 1)

EXHIBIT 2028

LG Elecs. v. Cypress Semiconductor
IPR2014-01405, U.S. Pat. 6,493,770

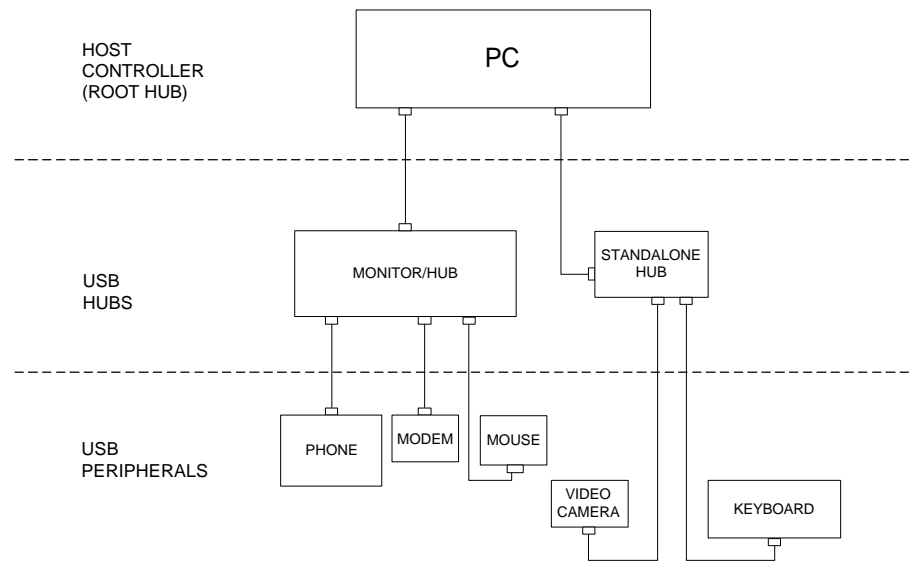

FIGURE 1

Since a hub can connect with other hubs, this creates multiple tiers of peripheral stars in the bus topology. A USB hub consists of two major functions; a hub controller and repeater. The repeater function takes the communication packet and “boosts” them up to the host controller (or another hub) or back to the peripheral. USB hubs come in two types; standalone or compound device. Standalone hubs typically have 4 expansion ports. Alternatively, a hub which combines other functions such as the keyboard and monitor is known as a compound device.

The last leg of the star is the peripheral. Peripherals can have a single function, or can be combined with multiple functions. Multiple function peripherals are known as composite devices (as opposed to the compound device for hubs). Anchor Chip’s USB solutions are well-suited for composite peripheral devices since the configurable architecture allows the support of multiple functions. As mentioned previously, peripherals are categorized as fully rated at 12 Mbps or low-speed at 1.5 Mbps.

USB Connections

One of the great outcomes from the conversion to USB is the simplicity of connections. There are only two types of connections for all hubs and peripherals. It is literally impossible for the user to screw the connection up as the two types of connectors are physically incompatible. The connector which is nearest the host controller or the hub (the upstream side) is called a Series A connector and shaped in a rectangular fashion (See Figure 2).



Figure 2

The connector which is nearest the peripheral or downstream side is called the Series B connector and is a more square shape with two corners shaved for orientation purposes. While the host controller will only have Series A connections, hubs have both Series A and Series B connections. If the peripheral has a cable attachment it will have a Series A plug at the other end to attach to a hub or the host controller port. With the tiered star topology, the Series A connection is always at the upstream portion of the star while the Series B connection is at the downstream connection (See Figure 3).

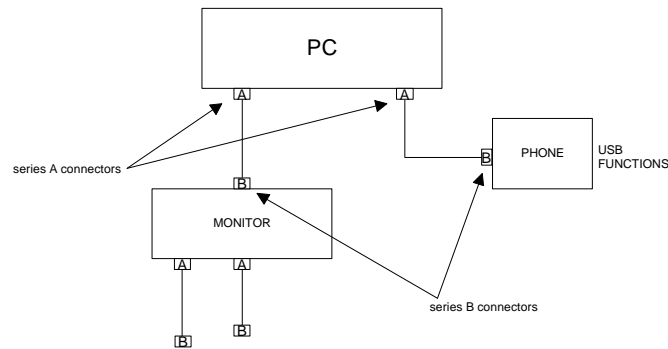

FIGURE 3

For fully rated connections at 12 Mbps, the cable length can extend up to 5 meters. For low-speed peripherals, the cable is limited to 3 meters between connections. Fully rated USB cables are shielded providing higher performance and longer length capability. Low speed cables are unshielded yielding lower cost.

Another aspect USB simplifies is the actual wire connection between devices. Instead of a variety of different cables which differ in the number of signal wires, all USB connections use four wires. Two are for the power supply (power and ground) and two for differential signaling (D+ and D-). A fully rated peripheral is identified by 1.5 K Ω pull-up resistor on the D+ line. A low speed peripheral is identified by the system by a 1.5 K Ω pull-up resistor on the D- line.

Power

All USB ports supply power for devices that are to be attached. Both hubs and peripheral may be self-powered implementing your own power-supply or be bus-powered. Bus-powered hubs and peripherals derive their entire power requirements from the USB cable. A fully rated port must be able to handle 500 mA of current to an attached device. Self-powered hubs can usually supply the maximum rated power each port. However, bus-powered hub have only the power they receive from the upstream cable, severely limiting their ability to supply full current needs of a peripheral. For devices that are attached to a bus-powered hub, the maximum amount of current they can draw is 100 mA.

Prior to being configured, USB devices must not draw more than 100 mA of current. After configuration, the peripheral can draw more current based on the configuration setting.

USB has numerous power conservation modes. There is suspend, an option whereby power consumption is curtailed through software control. There are two types off suspend; global and selective. All devices must support both types of suspend modes. Global suspend places all USB devices in a suspended state. Selective suspend places only devices which have been inactive in a suspended state. Devices enter suspend after 3 ms of no bus activity and must consume no more than 500uA total. The suspend current of 500 uA is more difficult than meets the eye as 200 uA is used due to the 1.5 K Ω pull-up resistor, leaving only 300 uA for the rest of the device peripheral.

The EZ-USB family is designed to operate at extremely low power; being one of the few USB devices able to operate at 3.3V. With this low power, it is ideal for bus-powered high speed peripherals.

USB SOFTWARE

USB Communication Model

Now here is the hard part. Because USB simplifies hardware connections, the complexity shifts to a protocol that can accommodate the variety of peripheral devices. Although the bus topology of a USB system has multiple tiers of communications through hubs, the communication can be modeled from the USB host to the peripheral as a one-to-one connection. This is referred to as logical connections to the USB host.

At the center of the communication model is the USB host who is the master of the USB system. The USB host acts as a traffic cop, controlling and scheduling all activities attached to the port. This is called a host-based communication model. The USB host is the only device that uses system resources requiring host memory locations, I/O address space and IRQ lines. Remember, USB peripherals are no longer mapped into memory or I/O address space, nor do they use IRQ lines or DMA channels.

The USB host controller initiates transactions via its root hub or hubs. The host controller initiates a start of a frame (SOF) every 1 ms. After the SOF, communication transactions between the hubs/peripherals and the host occur within the 1 ms time frame. The host may schedule a single data transfer by the peripheral over one large block within a 1 ms frame or over several consecutive frames. The actual scheduling depends on a number of factors including; transaction traffic, type of transaction, and bandwidth requested by the peripheral.

When a USB peripheral initiates a transfer, it calls the USB system software and requests a transfer. The host will either accept the data transfer or reject the request. If the host acknowledges (ACK) the request, then an entire routine which consist of setup, data transfer and handshake occurs. If the host rejects the request, then a Not Acknowledgement (NAK) is sent back to the peripheral. The peripheral will then repeat the request waiting for an acceptance from the host for the transfer request.

USB Data Types and Endpoints

In line with achieving simplicity, USB categorizes the various data types into four specific data formats to be used for all peripheral functions. USB can be connected to support non-time sensitive data types such as print, text or graphics data or real-time data such as audio, voice, and compressed video. To accommodate the various data types there are four USB data transfer types; control, isochronous, bulk and interrupt.

Control transfers are bi-directional and intended as the primary communication between host and device for configuration, command or status information. Control transfers consist of 2 or 3 stages; a setup stage, data stage (may or may not exist) and status stage. Cyclic redundancy checks (CRC) is performed on control packets. Since accuracy is important for control packets, retransmission occurs for unrecoverable errors. Because the control transfer have two or three stages, they are completed over a few USB frames. Control transfers are given a guaranteed 10% bus allocation. Control packets have a maximum length of 64 bytes.

Isochronous transfers can be uni-directional or bi-directional and is specifically targeted for streaming data such as audio or video. Since isochronous data is time sensitive, it is guaranteed access to USB with reasonable limitations on the bandwidth of the whole USB bus. Should an error occur, the peripheral device will not retry to transmit data since constant data rate is the more important than accuracy of data. Streaming data is more tolerant to errors. The maximum packet size for isochronous transfer is 1024 bytes per 1 ms. This translates to a maximum data rates of 8.814 Mbps.

Bulk transfers can be uni-directional or bi-directional. It is ideal for large amounts of data whose integrity must be guaranteed, but whose delivery is not time critical. Printer data or scanner data is natural candidate for transmission via a bulk transfer. Bulk transfer is designed to be a filler, claiming unused bandwidth of USB when other transfer requirements on the bus have been met. All forms of error detection and recovery are used. Maximum packet size for bulk transfers is 64 bytes.

Interrupt transfers are not interrupts in the standard sense of interrupts used by PC platforms. Instead they are used to poll devices to determine if they have data that needs to be transferred to the host. Hence, the direction of interrupt transfers are always from the USB peripheral to the host (IN only). If a device does not have data to send, then the device returns a no acknowledge (NAK) indicating no data available. Delivery is guaranteed. Maximum packet size for interrupt transfers is 64 bytes. Interrupt OUT packets have been proposed for the next version of USB (Version 1.1)

Central to the USB communication model is the abstract concept of transferring data using pipes between the host and peripherals. This pipe medium can be further distributed into even smaller pipes, with each type of data requiring a separate tiny pipe. Each tiny pipe (endpoint) carries unique data type that is needed between the peripheral and the host. For instance, in a multimedia USB device, different endpoints would be required for voice (isochronous), data (bulk), and control information. Thus a total of 5 endpoints are required since two endpoints are needed for bi-directional data. (See Figure 4) All these data types are required to be treated differently and are separated through the use of endpoints.

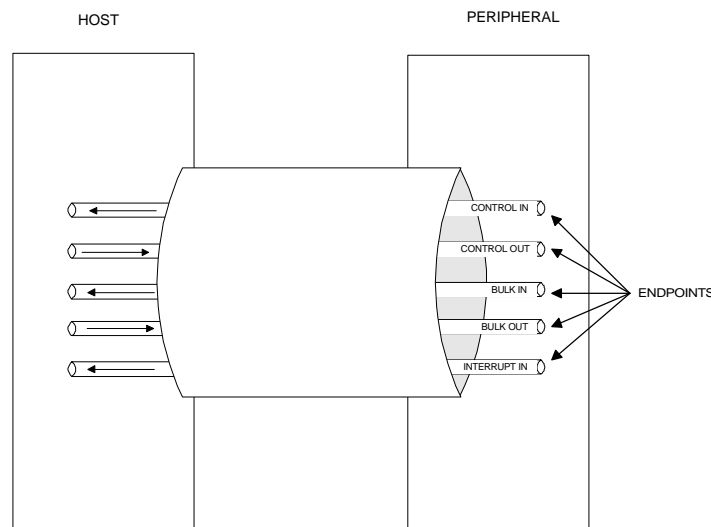

FIGURE 4

The Anchor Chips EZ-USB family has the most endpoints available in the market, supporting the maximum number of 31 endpoints allowed in the USB specification. With the vast number of endpoints, users have the flexibility to assign different buffers for each individual data stream, instead of consolidating various data streams into a single data type to be used for transmission. In addition, these endpoints can be programmed to be double-buffered, which improves transfer bandwidth in some applications.

SOFTWARE DEVELOPMENT

While the concept of USB is simple, the development of USB peripherals is not. Since the hardware scheme has been extremely simplified, the burden of complexity has moved toward software development. There will be a minimum of two designers needed to address two areas of development required for USB; device side and host side. For the USB device side, both hardware and firmware development will be necessary. For the USB host side, will need to assign a design team for device drivers and application software development.

Explore Litigation Insights

Docket Alarm provides insights to develop a more informed litigation strategy and the peace of mind of knowing you're on top of things.

Real-Time Litigation Alerts



Keep your litigation team up-to-date with **real-time alerts** and advanced team management tools built for the enterprise, all while greatly reducing PACER spend.

Our comprehensive service means we can handle Federal, State, and Administrative courts across the country.

Advanced Docket Research



With over 230 million records, Docket Alarm's cloud-native docket research platform finds what other services can't. Coverage includes Federal, State, plus PTAB, TTAB, ITC and NLRB decisions, all in one place.

Identify arguments that have been successful in the past with full text, pinpoint searching. Link to case law cited within any court document via Fastcase.

Analytics At Your Fingertips



Learn what happened the last time a particular judge, opposing counsel or company faced cases similar to yours.

Advanced out-of-the-box PTAB and TTAB analytics are always at your fingertips.

API

Docket Alarm offers a powerful API (application programming interface) to developers that want to integrate case filings into their apps.

LAW FIRMS

Build custom dashboards for your attorneys and clients with live data direct from the court.

Automate many repetitive legal tasks like conflict checks, document management, and marketing.

FINANCIAL INSTITUTIONS

Litigation and bankruptcy checks for companies and debtors.

E-DISCOVERY AND LEGAL VENDORS

Sync your system to PACER to automate legal marketing.