

EZ-USB™ Integrated Circuit

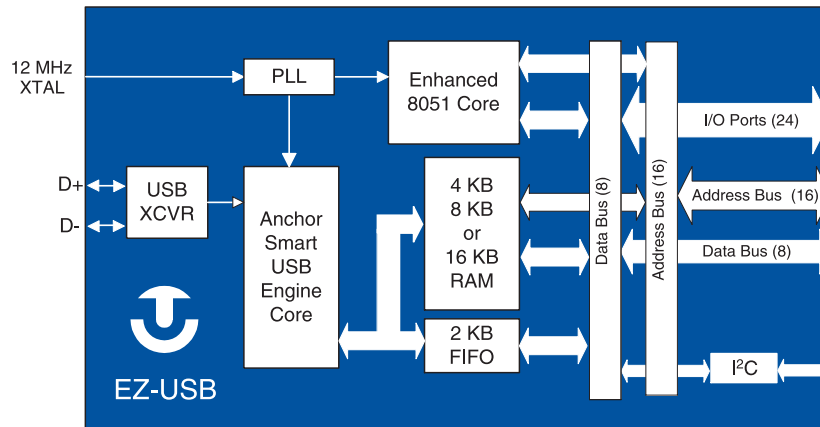

EZ-USB Family



The Anchor Chips EZ-USB™ family (AN21XX/AN23XX) provides significant improvements over other USB architectures including an enhanced 8051 core, 4, 8 or 16 Kbytes of RAM, an intelligent USB core, and high-performance I/O ports. The family includes 16 different products to accommodate the needs of different systems.

The enhanced 8051 core provides five times the performance of the standard 8051, while maintaining complete 8051 software compatibility. With on-chip RAM, firmware code can be downloaded from the host PC. This allows the peripheral manufacturer to easily modify and transfer new code to current and new users. This on-chip memory eliminates the need for external memory.

The EZ-USB family supports high-bandwidth transfers by providing an efficient mechanism to move data between external memory and the USB FIFOs. Using this “turbo mode,” the 8051 core can transfer 1024 bytes of data in or out of an isochronous FIFO in 338 microseconds. This leaves a high percentage of the bandwidth for the processor to service the application. The EZ-USB family also supports an equivalent data transfer rate for bulk packets of over 2 Mbytes per second, which is more than the USB bandwidth.

The EZ-USB family conforms to the high-speed (12 Mbps) requirements of USB Specification version 1.0, including support for remote wake-up. The internal SRAM replaces Flash memory, EEPROM, EPROM, or masked ROM that is conventionally used in other USB solutions.

The EZ-USB family offers two packages, a 44 PQFP and an 80 PQFP. All EZ-USB devices are pin- and software-compatible. And, all RAM versions have ROM equivalents to allow easy migration for high-volume applications.

Features

- Single-chip, low-power solution for high-speed USB peripherals
- Firmware downloadable
- High-performance I/O port
- Small board space (less than 1 square inch)
- 44 PQFP or 80 PQFP
- USB Specification 1.0 compliant
- Uses commercially-available 8051 software tools
- Thirty-one flexible endpoints
- All endpoints can be double buffered
- 4, 8 or 16 Kbytes of memory
- Five times the speed of a standard 8051
- Supports composite devices
- I²C controller
- Supports isochronous, bulk, control, and interrupt data
- On-chip PLL

EZ-USB Products

AN2121SC	AN2321SC
AN2125SC	AN2325SC
AN2126SC	AN2326SC
AN2131SC	AN2331SC
AN2135SC	AN2335SC
AN2136SC	AN2336SC
AN2131QC	AN2331QC
AN2141QC	AN2341QC

EXHIBIT 2025

LG Elecs. v. Cypress Semiconductor
IPR2014-01386, U.S. Pat. 6,012,103

With the EZ-USB family, the peripheral designer gains two overall advantages: First, the design is much simpler because of the chip's significant integration and built-in flexibility. Second, the EZ-USB architecture reduces software code significantly over other USB solutions. This combination gives users a quick and easy path toward obtaining a working prototype.

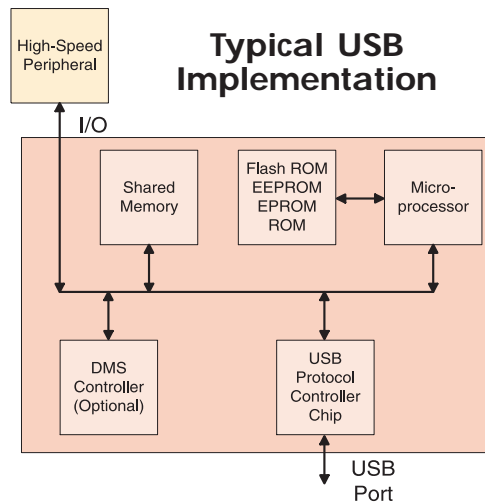

Anchor USB Solution

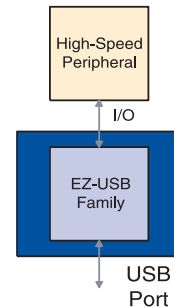

Anchor Chips' EZ-USB family eliminates the need to become an expert in USB. It allows the designer to take advantage of the benefits of USB without investing large amounts of time and energy. With the EZ-USB family, peripheral designers can have USB traffic running within hours, instead of weeks as with other USB solutions.

The EZ-USB family of controllers simplifies the process of implementing USB hardware and software development for peripheral manufacturers. Low-level USB protocol requirements are automatically handled by the Anchor smart USB core and the included software utilities.

1 A typical USB implementation uses nonvolatile memory (EPROM, EEPROM, Flash memory), a microprocessor, RAM, USB SIE and DMA. The EZ-USB family includes all the building blocks for a complete and low-cost USB solution in a single chip. The design is much simpler since timing and interface analysis are significantly reduced.

2 The EZ-USB RAM architecture provides design and software flexibility. Its "soft" configuration enables peripheral manufacturers and designers to make changes to the USB device through software. This means complete flexibility with minimal design risks.

3 The EZ-USB family uses an intelligent USB core to simplify 8051 firmware code by as much as 80%. This reduces the firmware designer's need to develop code to handle the low-level nuances of the USB specification. The designer is free to concentrate on higher level functions. EZ-USB firmware development is quick, requiring less binary code and reducing the likelihood of errors.

4 With the EZ-USB family's software utilities and tools, firmware development is simplified and accelerated. Firmware can be tested independent of drivers, allowing the firmware developer and driver software developer to write code simultaneously. They do not need each other to verify and test code. This dual path decreases software development time.



Features	Benefits
<i>Single-Chip Solution</i>	Lower overall system cost Minimum board space with 44 PQFP and 80 PQFP packages Quicker design and faster time to market than other USB solutions Minimal design resources
<i>RAM Architecture</i>	Quick changes in firmware and driver code Updates in the field via software downloads Flexibility in multiple configurations Dynamic changes in performance/properties based on user's needs
<i>High-Performance I/O</i>	Transfers a full 1024-byte isochronous packet within one USB frame Provides highest quality full-motion video or audio performance Data I/O rate greater than 2 Mbyte/sec for bulk and isochronous packets Fastest response time for the end user
<i>4- 8- or 16-Kbyte Pin- and Software-Compatible Family</i>	Easy transition from RAM to ROM for high-volume applications Pin- and software-compatible options for program code growth No change in hardware as needs change Lowers system cost since only minimal memory size is needed
<i>EZ-USB Firmware Architecture</i>	Significantly less 8051 USB code since core handles most USB activity Shortened USB learning curve Quicker working prototypes and final production models More software development time to devote to the peripheral function
<i>Enhanced 8051 Core</i>	Five times faster performance than 8051 No new 8051 software tools to learn
<i>Anchor USB Core/ ReNumeration Capability</i>	External EPROM components eliminated A quick path to working prototypes User-selectable changes in peripheral properties without disconnecting
<i>EZ-USB Xcelerator Development Kit</i>	Speedier firmware and driver development Independent development of firmware and driver Fewer software errors No custom Windows® driver needed to test USB traffic and firmware
<i>Low 3.3V Power</i>	Meets the 100 mA power-up specification Useful in bus-powered applications Useful in power-sensitive applications such as battery-powered equipment
<i>Five External Interrupts</i>	Flexible without sacrificing standard 8051 interrupts
<i>Separate Memory Expansion Port</i>	Design flexibility in USB program code No sacrifice in I/O capability for high-functionality peripheral devices Non-multiplexed, requiring no external latch

Soft Configuration

The focus of the EZ-USB family is to provide the peripheral designer a multitude of design configurations and migration paths. The "soft," programmable nature of the EZ-USB architecture provides flexibility while minimizing risks.

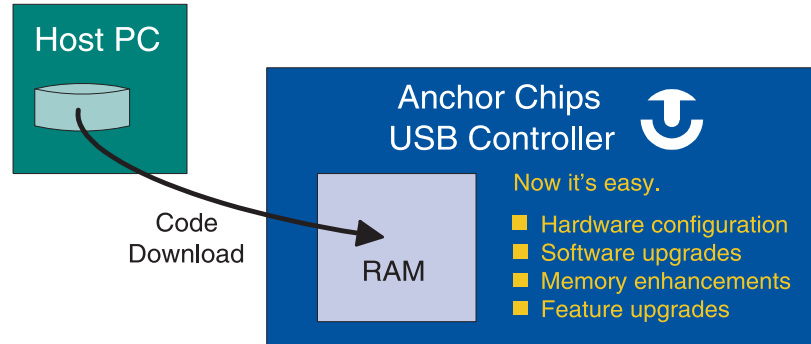

USB requires synchronization between four major technology suppliers: operating system, UHCI/OHCI interfaces, hub controllers, and peripheral devices. In a traditional hardware configuration, ensuring that a peripheral device will work with every combination of these technologies is a time-consuming and expensive task.

Using the EZ-USB chip's "soft" configuration, the peripheral developer can easily devise workarounds or accommodate dynamic changes. At the same time, there is minimum risk to design implementation.

Peripheral manufacturers can provide firmware updates in conjunction with driver changes via a floppy disk or through Internet downloads. Thus,

software device configurability provides easy field updates, last minute software code changes prior to production, or alterations due to ever-changing standards. In these ways, the EZ-USB chip makes development easier and guards against product obsolescence.

RAM Architecture

With an enhanced 8051 core combined with 4, 8, or 16 Kbytes of SRAM in a single chip, users have a complete solution. The 8051's firmware can be stored in the hard disk (along with the driver) and downloaded into the peripheral during its initialization. That makes updates as easy as updating any other PC software.



Enumeration and ReEnumeration

Anchor Chips' proprietary ReNumeration™ function is the means by which the enhanced 8051 firmware is downloaded.

How It Works

Upon power-up or plug-in, the EZ-USB chip automatically enumerates as a default USB device. This allows the USB core

to download 8051 code. The USB core logic inside EZ-USB performs this initial enumeration and code download while holding the 8051 in reset.

Once enumerated, the host PC downloads 8051 code into EZ-USB RAM over the USB interface. (Anchor Chips supplies the software tools to incorporate the loader into any application). The downloaded 8051 code

contains program, data, and enumeration tables. Once loaded, the EZ-USB core performs a ReNumeration cycle to simulate a USB disconnect and reconnect to come back as a completely new USB device.

This entire sequence of enumeration, download and ReNumeration happens quickly (less than a quarter of a second) and is transparent to the user.

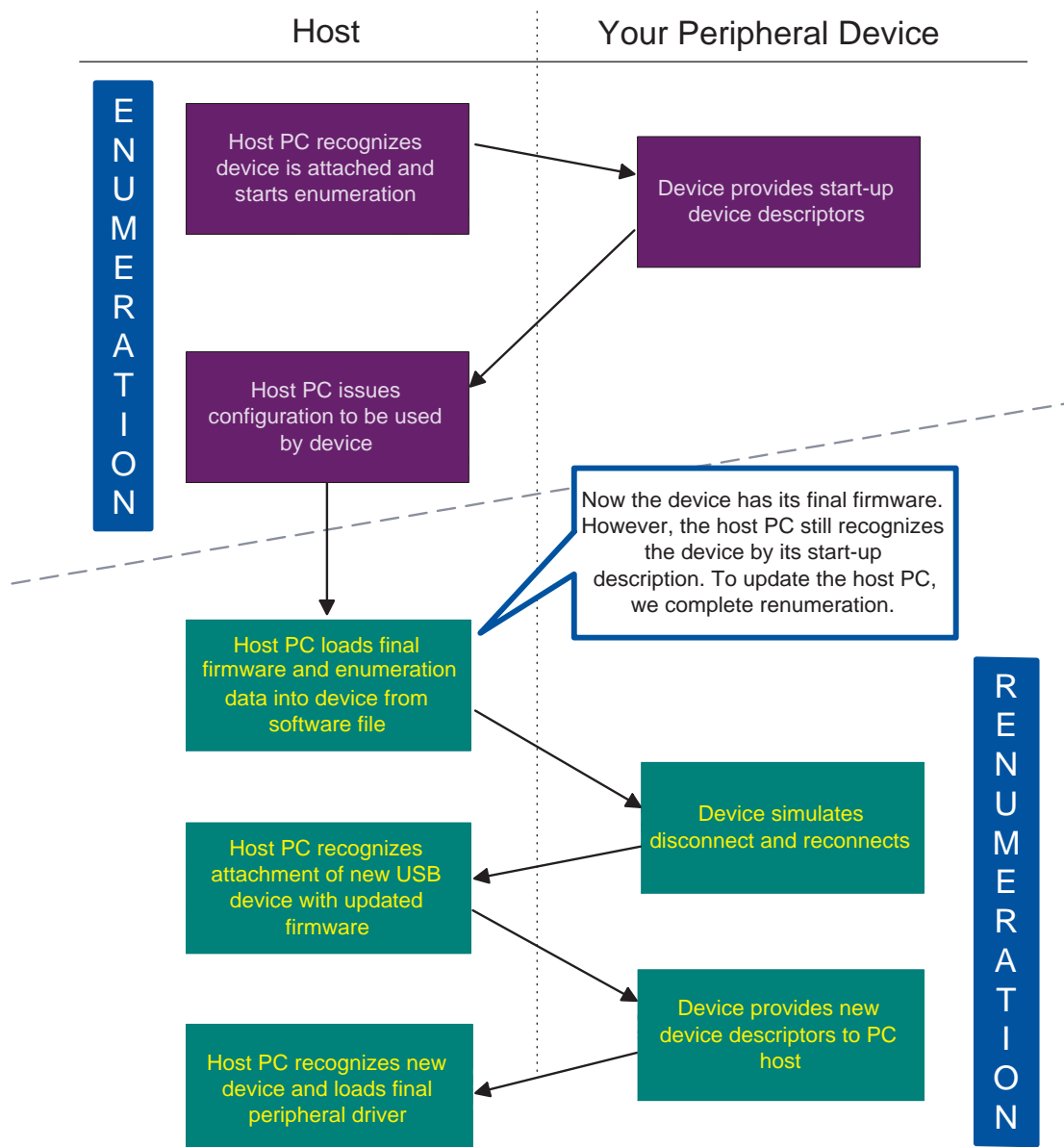

Explore Litigation Insights

Docket Alarm provides insights to develop a more informed litigation strategy and the peace of mind of knowing you're on top of things.

Real-Time Litigation Alerts



Keep your litigation team up-to-date with **real-time alerts** and advanced team management tools built for the enterprise, all while greatly reducing PACER spend.

Our comprehensive service means we can handle Federal, State, and Administrative courts across the country.

Advanced Docket Research



With over 230 million records, Docket Alarm's cloud-native docket research platform finds what other services can't. Coverage includes Federal, State, plus PTAB, TTAB, ITC and NLRB decisions, all in one place.

Identify arguments that have been successful in the past with full text, pinpoint searching. Link to case law cited within any court document via Fastcase.

Analytics At Your Fingertips



Learn what happened the last time a particular judge, opposing counsel or company faced cases similar to yours.

Advanced out-of-the-box PTAB and TTAB analytics are always at your fingertips.

API

Docket Alarm offers a powerful API (application programming interface) to developers that want to integrate case filings into their apps.

LAW FIRMS

Build custom dashboards for your attorneys and clients with live data direct from the court.

Automate many repetitive legal tasks like conflict checks, document management, and marketing.

FINANCIAL INSTITUTIONS

Litigation and bankruptcy checks for companies and debtors.

E-DISCOVERY AND LEGAL VENDORS

Sync your system to PACER to automate legal marketing.