



US006243507B1

(12) **United States Patent**
Goldstein et al.

(10) **Patent No.:** **US 6,243,507 B1**
(45) **Date of Patent:** **Jun. 5, 2001**

(54) **CONNECTION-VERIFICATION IN OPTICAL MEMS CROSSCONNECTS VIA MIRROR-DITHER**

(75) Inventors: **Evan Lee Goldstein**, Princeton; **Lih-Yuan Lin**, Middletown; **Leda Maria Lunardi**, Marlboro, all of NJ (US)

(73) Assignee: **AT&T Corp.**, New York, NY (US)

(*) Notice: Subject to any disclaimer, the term of this patent is extended or adjusted under 35 U.S.C. 154(b) by 0 days.

(21) Appl. No.: **09/472,682**

(22) Filed: **Dec. 27, 1999**

Related U.S. Application Data

(60) Provisional application No. 60/137,840, filed on Jun. 7, 1999.

(51) **Int. Cl.**⁷ **G02B 6/12**

(52) **U.S. Cl.** **385/13; 385/17; 385/18; 385/19**

(58) **Field of Search** **385/16-19, 12-14; 359/212, 223, 225; 250/216, 234**

(56) **References Cited**

U.S. PATENT DOCUMENTS

5,136,671	8/1992	Dragone	385/46
5,155,623	10/1992	Miller et al.	359/495
5,206,497	4/1993	Lee	250/201.1
5,960,132	9/1999	Lin	385/18
6,144,781	* 11/2000	Goldstein et al.	385/18

OTHER PUBLICATIONS

H. Toshiyoshi et al., "Electrostatic Micro Torsion Mirrors for an Optical Switch Matrix," *Journal of Microelectromechanical Systems*, vol. 5, No. 4, Dec. 1996, pp. 231-237.

B. Behin et al., "Magnetically Actuated Micromirrors for Fiber-Optic Switching," Solid-State Sensor and Actuator Workshop, Hilton Head, South Carolina, Jun. 8-11, 1998, pp. 273-276.

K. S. J. Pister et al., "Microfabricated Hinges," *Sensors and Actuators*, vol. A, No. 33 (1992), pp. 249-256.

T. Akiyama et al., "A Quantitative Analysis of Scratch Drive Actuator Using Buckling Motion," *IEEE Workshop on Micro Electro Mechanical Systems*, Amsterdam, The Netherlands, Jan. 29-Feb. 2, 1995, pp. 310-315.

R. T. Chen et al., "A Low Voltage Micromachined Optical Switch By Stress-Induced Bending," 12th IEEE International Conference On Micro Electro Mechanical Systems, Orlando, Florida, Jan. 17-21, 1999, 5 pages.

Cronos Integrated Microsystems, Inc., "Three-Layer Polysilicon Surface Micromachine Process," Aug. 24, 1999, pp. 1-8 (<http://mems.mcnc.org>).

L. Y. Lin et al., "Free-Space Micromachined Optical Switches for Optical Networking," *IEEE Journal of Selected Topics in Quantum Electronics*, vol. 5, No. 1, Jan./Feb. 1999, pp. 4-9.

(List continued on next page.)

Primary Examiner—Darren Schuberg

Assistant Examiner—Fayez Assai

(57) **ABSTRACT**

Integrated connection-verification system for use in a micro-electro-mechanical system (MEMS) crossconnect device. The system uses application of a dithering signal such as a sinusoidal bias to an electrode plate associated with a micro-mirror switching element to dither the micro-mirror. The optical signal from the dithering micro-mirror is fed through a beam splitter, a portion of the optical signal thus being directed to a photodetector. If intensity modulation in the optical signal corresponding to the frequency of the dithering signal is detected by the photodetector associated with the micro-mirror, the connection path between the desired input and output ports is verified.

11 Claims, 9 Drawing Sheets

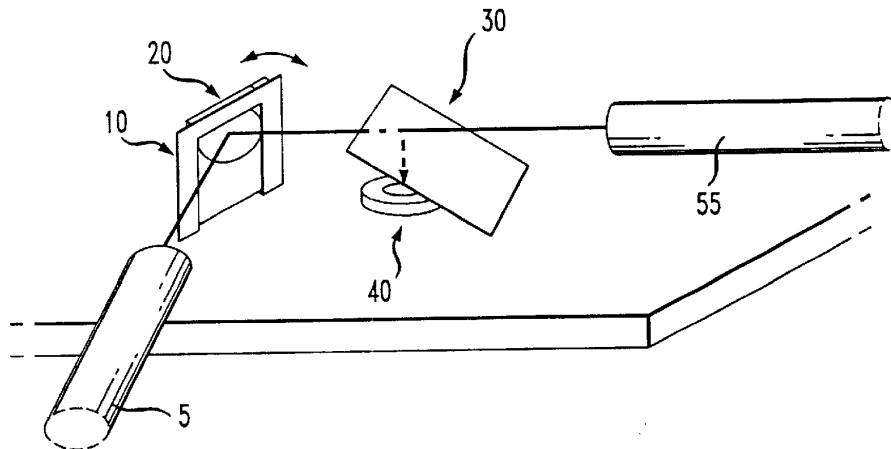

OTHER PUBLICATIONS

L. Y. Lin et al., "High-Density Micromachined Polygon Optical Crossconnects Exploiting Network Connection-Symmetry," *IEEE Photonics Technology Letters*, vol. 10, No. 10, Oct. 1998, pp. 1425-1427.
E. L. Goldstein et al., "National-Scale Networks Likely to Be Opaque," *Lightwave*, Feb. 1998, pp. 91-95.
C-K. Chan et al., "A Novel Optical-Path Supervisory Scheme for Optical Cross Connects in All-Optical Transport

Networks," *IEEE Photonics Technology Letters*, vol. 10, No. 6, Jun. 1998, pp. 899-901.

L. Y. Lin et al., "Optical Cross-connect Integrated System (OCCIS): A Free-Space Micromachined Module for Signal and Switching Configuration Monitoring," *IEEE LECS Summer Topical Meeting: Optical MEMS*, Monterey, California, Jul. 20-22, 1998, 3 pages.

* cited by examiner

FIG. 1

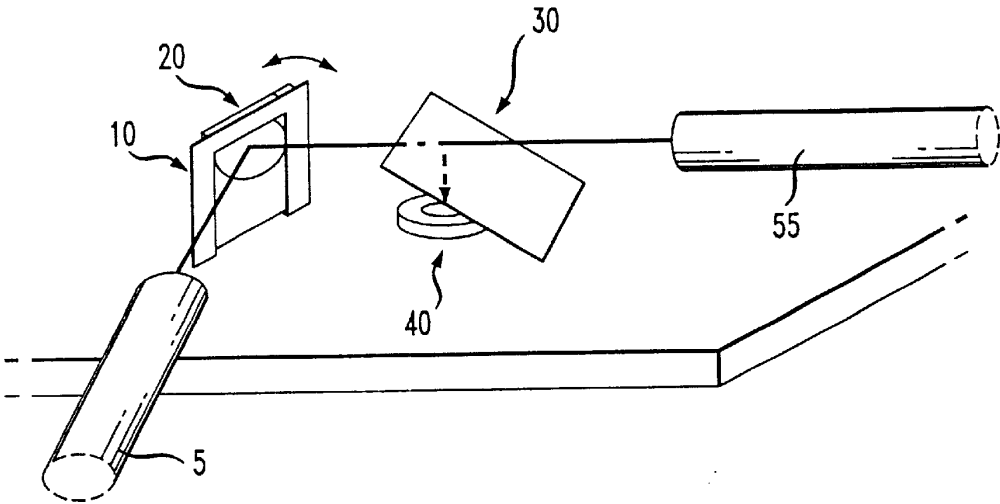

FIG. 2

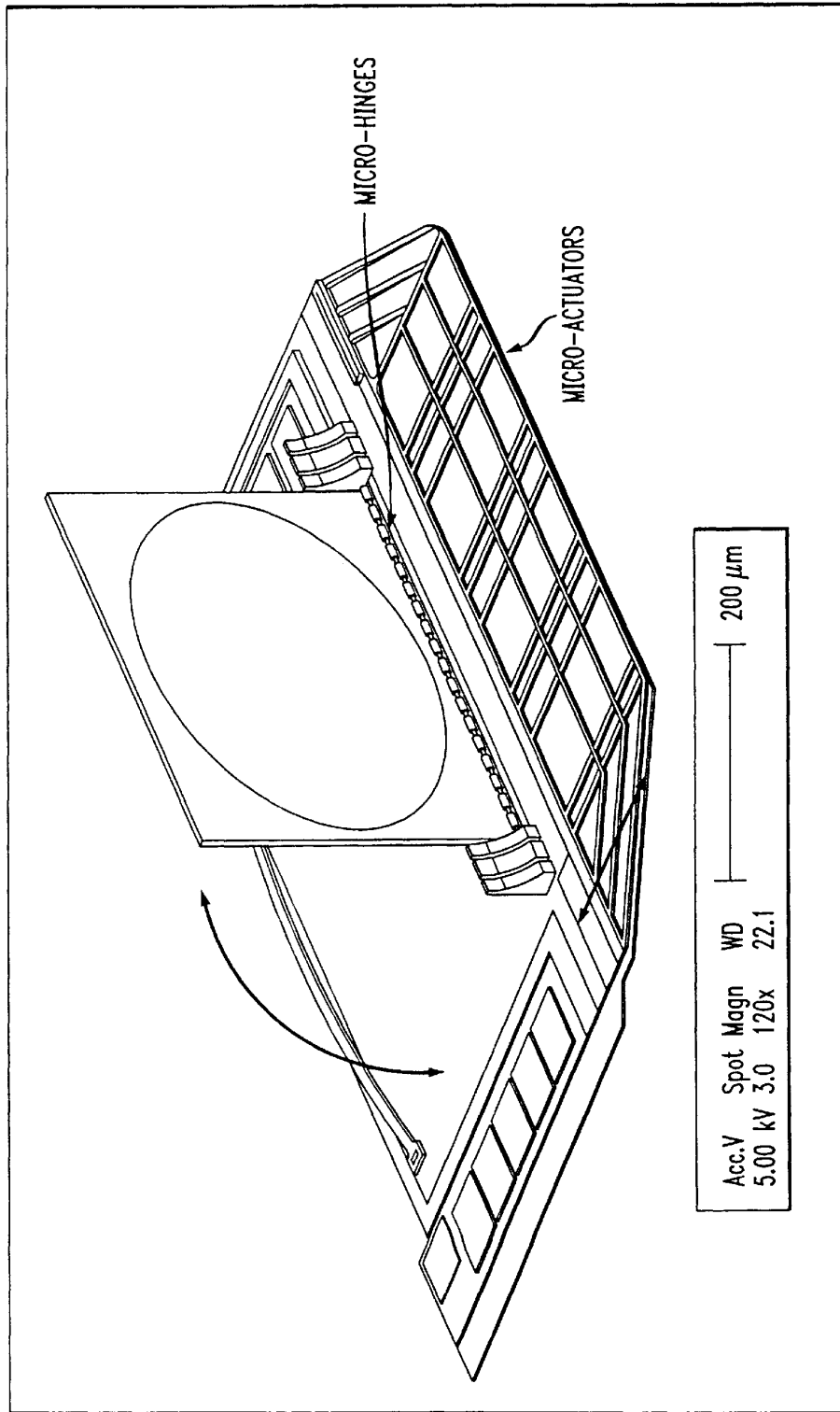
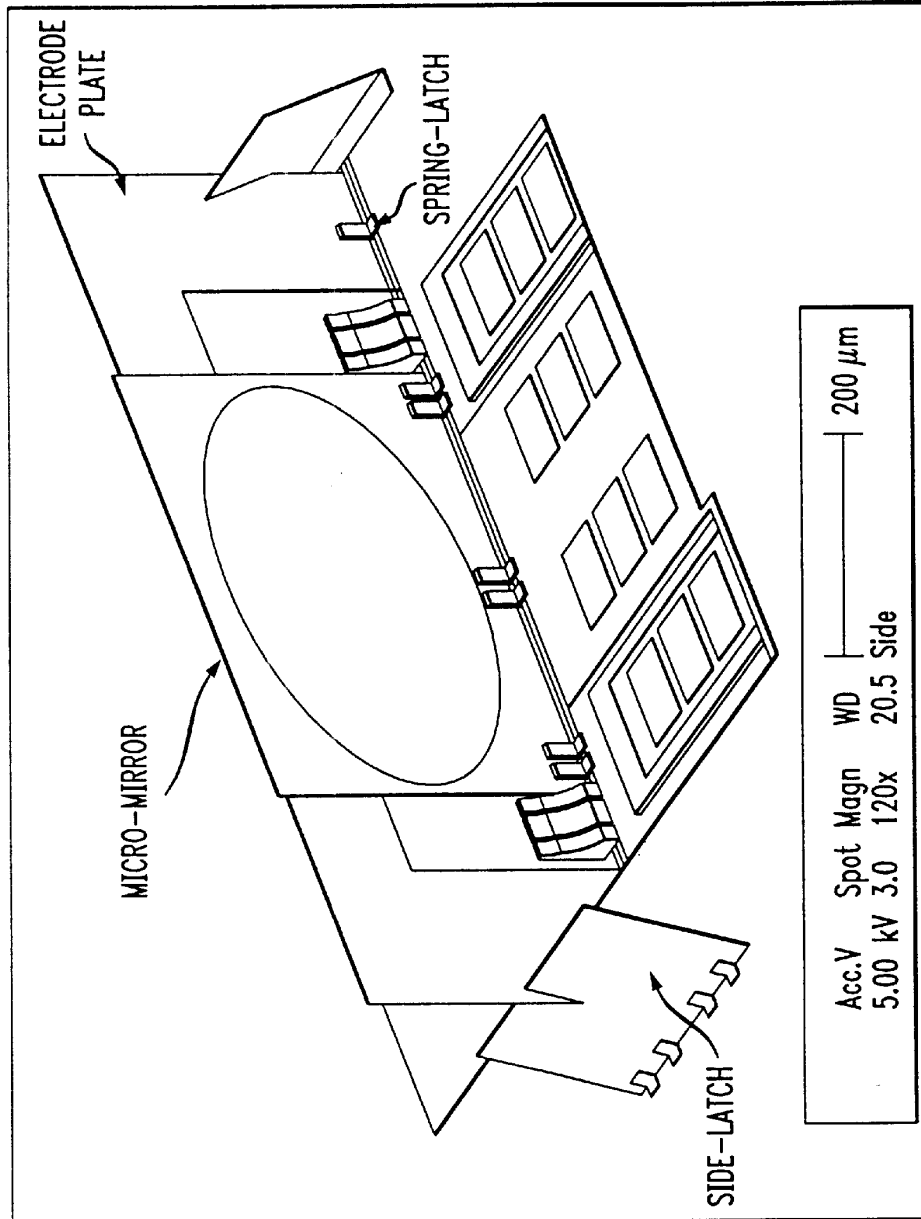

FIG. 3



Explore Litigation Insights

Docket Alarm provides insights to develop a more informed litigation strategy and the peace of mind of knowing you're on top of things.

Real-Time Litigation Alerts



Keep your litigation team up-to-date with **real-time alerts** and advanced team management tools built for the enterprise, all while greatly reducing PACER spend.

Our comprehensive service means we can handle Federal, State, and Administrative courts across the country.

Advanced Docket Research



With over 230 million records, Docket Alarm's cloud-native docket research platform finds what other services can't. Coverage includes Federal, State, plus PTAB, TTAB, ITC and NLRB decisions, all in one place.

Identify arguments that have been successful in the past with full text, pinpoint searching. Link to case law cited within any court document via Fastcase.

Analytics At Your Fingertips



Learn what happened the last time a particular judge, opposing counsel or company faced cases similar to yours.

Advanced out-of-the-box PTAB and TTAB analytics are always at your fingertips.

API

Docket Alarm offers a powerful API (application programming interface) to developers that want to integrate case filings into their apps.

LAW FIRMS

Build custom dashboards for your attorneys and clients with live data direct from the court.

Automate many repetitive legal tasks like conflict checks, document management, and marketing.

FINANCIAL INSTITUTIONS

Litigation and bankruptcy checks for companies and debtors.

E-DISCOVERY AND LEGAL VENDORS

Sync your system to PACER to automate legal marketing.