



US006798992B1

(12) **United States Patent**  
**Bishop et al.**

(10) **Patent No.:** **US 6,798,992 B1**  
(45) **Date of Patent:** **\*Sep. 28, 2004**

(54) **METHOD AND DEVICE FOR OPTICALLY CROSSCONNECTING OPTICAL SIGNALS USING TILTING MIRROR MEMS WITH DRIFT MONITORING FEATURE**

(58) **Field of Search** ..... 398/45, 46, 49, 398/48, 50, 52, 55, 56, 12, 19; 356/73.1; 385/16, 17, 18, 19, 20-24, 33, 119

(75) **Inventors:** **David John Bishop**, Summit, NJ (US); **Randy Clinton Giles**, Whippany, NJ (US)

(56) **References Cited**

U.S. PATENT DOCUMENTS

6,198,856 B1 \* 3/2001 Schroeder et al. .... 385/17  
6,301,402 B1 \* 10/2001 Bhalla et al. .... 385/16  
6,411,751 B1 \* 6/2002 Giles et al. .... 385/16  
6,424,757 B1 \* 7/2002 Sparks et al. .... 385/16

(73) **Assignees:** **Agere Systems Inc.**, Allentown, PA (US); **Lucent Technologies Inc.**, Murray Hill, NJ (US)

OTHER PUBLICATIONS

(\*) **Notice:** Subject to any disclaimer, the term of this patent is extended or adjusted under 35 U.S.C. 154(b) by 0 days.

U.S. application No. 09/512174 (Aksyuk et al) filed on Feb. 24, 2000.\*

This patent is subject to a terminal disclaimer.

\* cited by examiner

*Primary Examiner*—Hanh Phan

(21) **Appl. No.:** **09/518,070**

(57) **ABSTRACT**

(22) **Filed:** **Mar. 2, 2000**

**Related U.S. Application Data**

(60) Provisional application No. 60/164,459, filed on Nov. 10, 1999.

A device and method for detecting rotational drift of mirror elements in a MEMS tilt mirror array used in an optical crossconnect. The optical crossconnect directs optical signals from an input fiber to an output fiber along an optical path by rotatably positioning mirror elements in desired positions. A monitoring device disposed outside of the optical path is used to obtain images of the MEMS array or to transmit and receive a test signal through the crossconnect for detecting the presence of mirror element drift.

(51) **Int. Cl.<sup>7</sup>** ..... **H04J 14/00**

(52) **U.S. Cl.** ..... **398/45; 398/50; 398/52; 398/55; 398/56; 398/12; 398/19; 398/47; 398/48; 398/46; 385/16; 385/17; 385/18; 385/19; 385/20; 385/21; 385/22; 385/23; 385/24; 385/33; 385/119; 356/73.1**

**16 Claims, 2 Drawing Sheets**

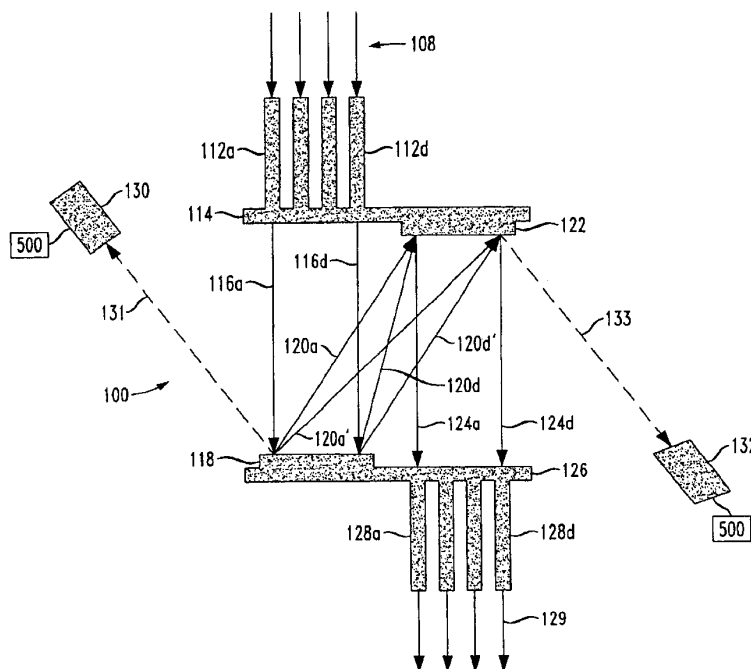

FIG. 1

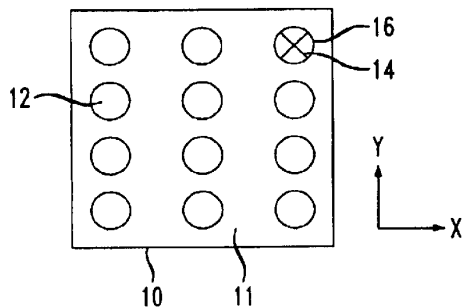

FIG. 2

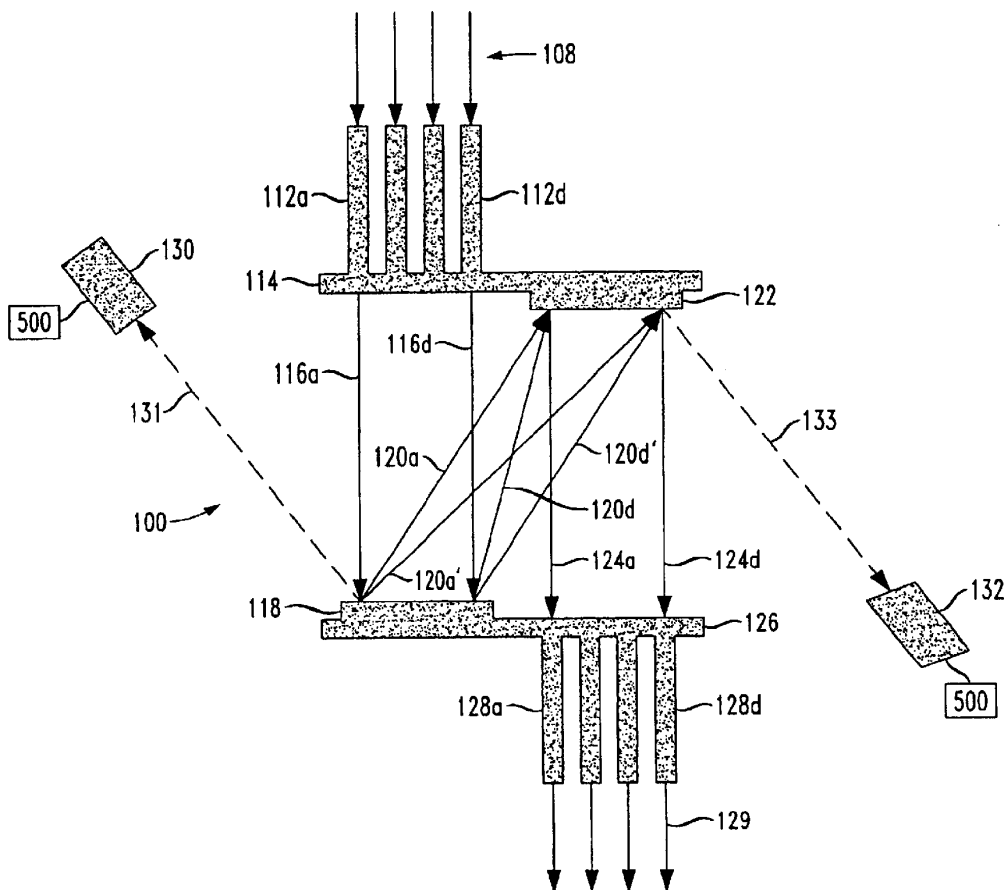
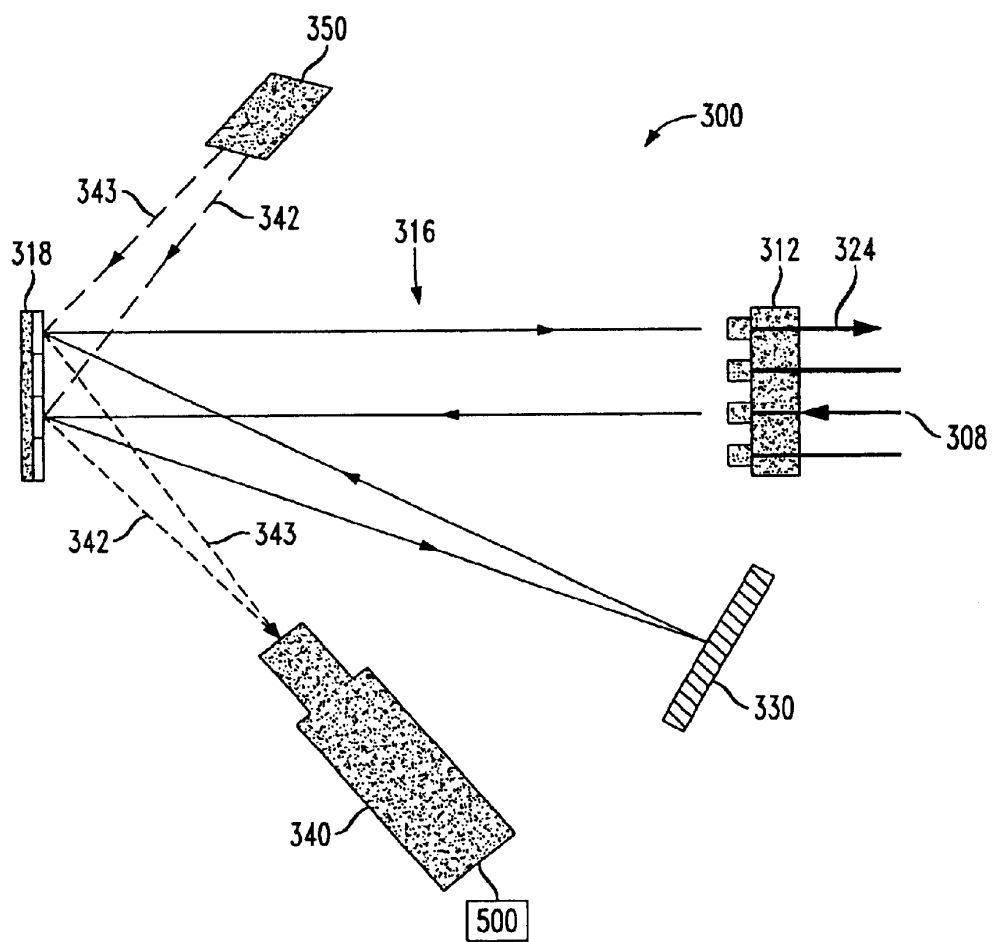

FIG. 3



**METHOD AND DEVICE FOR OPTICALLY  
CROSSCONNECTING OPTICAL SIGNALS  
USING TILTING MIRROR MEMS WITH  
DRIFT MONITORING FEATURE**

This application is based on U.S. Provisional Application Ser. No. 60/164,459 filed on Nov. 10, 1999.

**BACKGROUND OF THE INVENTION**

**1. Field of the Invention**

The present invention pertains to fiber optic communications systems and, more particularly, to monitoring devices and methods for monitoring shifts in optical crossconnect configurations utilizing micro electromechanical systems (MEMS) tilting mirror arrays.

**2. Description of the Related Art**

In fiber optic communication systems, signal routing is essential for directing an optical signal carrying data to an intended location. Existing routing techniques typically experience optical power loss due to inefficient coupling of optic signals between input and output fibers. This increases the dependence on optical power sources (e.g., pump lasers) which are used to compensate for power losses by injecting optical power back into the optical system. The need for optical power sources increases the overall cost of the optical system.

Another criteria for signal routing is the ability to direct a signal received from one of a plurality of input fibers or ports to any of a plurality of output fibers or ports without regard to the frequency of the optical signal.

Free-space optical crossconnects allow interconnecting among input and output ports in a reconfigurable switch fabric. An example of such an optical crossconnect utilizing micro-electromechanical systems (MEMS) tilting mirror devices is disclosed in commonly owned and copending U.S. patent application Ser. No. 09/410,586, filed Oct. 1, 1999. By adjusting the tilt angles of the MEMS mirror devices, optical signals can be directed to various destinations, i.e. to numerous output fibers.

MEMS devices and, in particular, tilting mirror devices are susceptible to unwanted movement or drift due to external factors such as temperature changes and mechanical fatigue experienced by actuator elements used to deploy and control the individual mirror elements. As a result, optical signal power may be lost due to misalignment of the reflected optical signal with its intended target (e.g. an output fiber). Accordingly, a system is desired to monitor MEMS optical crossconnect configuration to provide for displacement adjustment.

**SUMMARY OF THE INVENTION**

An optical crossconnect device having a monitoring feature for detecting optical signal drift is provided. The device provides optical connection of optic signals between input fibers and output fibers by using a MEMS tilt mirror array. The MEMS array includes a plurality of tiltable mirror elements which are positionable in an intended orientation for directing optical signals, but which are susceptible to drift that causes degradation in the optical coupling of the signals to the output fibers. A monitoring device positioned outside of the optical path dynamically monitors the position of one or more of the mirror elements to detect drift.

In a preferred embodiment, the monitoring device is a camera for obtaining an image of one or more mirror elements.

In another embodiment, the monitoring device comprises an optical transmitter and an optical receiver for transmitting a test signal through the optical crossconnect to monitor mirror position drift.

In yet another embodiment, a pattern is formed on one or more of the mirror elements and an image or reflection of the pattern is obtained for determining the presence of mirror drift.

A method is also described for monitoring mirror element positions of mirror elements in a MEMS tilt mirror array used in an optical crossconnect. The method is used with a MEMS mirror array having mirror elements disposed at desired tilt positions for crossconnecting an optic signal between an input fiber and an output fiber along an optical path. A monitoring device disposed outside of the optical path monitors the positions of the mirror elements to detect when position drift occurs. The mirror positions are then adjusted by forming control signals based on the detected drift and applying the control signals to the drifted mirror elements.

Other objects and features of the present invention will become apparent from the following detailed description considered in conjunction with the accompanying drawings. It is to be understood, however, that the drawings are designed solely for purposes of illustration and not as a definition of the limits of the invention, for which reference should be made to the appended claims. It should be further understood that the drawings are not necessarily drawn to scale and that, unless otherwise indicated, they are merely intended to conceptually illustrate and explain the structures and procedures described herein.

**BRIEF DESCRIPTION OF THE DRAWINGS**

In the drawings, wherein like reference numerals denote similar elements throughout the several views.

FIG. 1 is a planar view of an example of a MEMS mirror array used in connection with the present invention;

FIG. 2 is a schematic representation of an optical crossconnect monitoring device in accordance with one embodiment of the present invention; and

FIG. 3 is a schematic representation of a monitoring device for a "folded" optical crossconnect in accordance with another embodiment of the present invention.

**DETAILED DESCRIPTION OF THE  
PREFERRED EMBODIMENTS**

Arrays of two-axis tilt mirrors implemented using micro-electromechanical systems (MEMS) technology in accordance with the invention allow for the construction of large scale optical crossconnects for use in optical systems. Optical crossconnects are commonly employed to connect a number of input optical paths to a number of output optical paths. A typical requirements of optical crossconnects is that any input be capable of being connected to any output. One example of a MEMS mirror array 10 is depicted in FIG. 1. The mirror array 10 includes a plurality of tilt mirrors 12 formed on a substrate 11, mounted to actuation members or springs 14 and controlled by electrodes (not shown). Each mirror 12 is approximately 100–500 Microns across, may be shaped as square, circular or elliptical, and is capable of operatively rotating or tilting about orthogonal X-Y axes, with the tilt angle being selectively determined by the amount of voltage applied to the control electrodes. Further details of the operation of the MEMS mirror array 10 are found in copending U.S. patent application Ser. No. 09/415,

178, filed Oct. 8, 1999, the entire contents of which are incorporated herein by reference. The general concept of utilizing two or more such tilt mirror arrays **10** to form an optical crossconnect is disclosed in copending U.S. patent application Ser. No. 09/410,586, filed Oct. 1, 1999, the entire contents of which are also incorporated herein by reference.

The use of one or more MEMS tilt mirror arrays in conjunction with a lens array is disclosed in co-pending U.S. patent application Ser. No. 09/512,174, filed Feb. 24, 2000, the entire content of which is also incorporated herein by reference. As disclosed in that application, various optical crossconnect configurations of compact size (i.e. minimal spacing between crossconnect components) and exhibiting minimal optical power loss can be realized. One such optical crossconnect **100** discussed in the aforementioned application is depicted in FIG. 2. Crossconnect **100** receives input optic signals **108** through a plurality of optic fibers **112**, preferably formed in an array as is well known in the art. For ease of illustration fiber array **110** is shown as a one-dimensional array having four fibers **112a**, **112b**, **112c**, **112d**. It is in any event to be understood that fiber array **112** as well as other fiber arrays discussed herein are preferably two-dimensional arrays such as, for example, N×N arrays.

Fiber array **112** transmits the optical signals **108** to an array of lenses **114** that function as collimating lenses. The lens array **114** is positioned relative to fiber array **112** so that each lens communicates with a corresponding fiber for producing pencil beams **116** from the optic signals **118**. Thus, beam **116a** is produced from a signal carried by fiber **112a**, beam **116d** is produced from a signal carried by fiber **112d**, etc.

A first MEMS tilt mirror array **118**, also referred to as the input array, is positioned in alignment with lens array **114** so that each mirror element **12** will receive a corresponding beam **116**. The mirror elements are operatively tilted, in a manner discussed in application Ser. No. 09/415,178, to reflect the respective beams **116** to a second or output MEMS mirror array **122** positioned in optical communication with MEMS array **118**. Depending on the tilt angle of each mirror element in input MEMS array **118**, the reflected signals can be selectively directed to specific mirror elements in output MEMS array **122**. To illustrate this principle, beam **116a** is shown in FIG. 2 generating reflection beams **120a** and **120a'** and beam **116d** is shown in the figure generating reflection beams **120d** and **120d'**. These beams are received by mirror elements in the output MEMS array **122** and are directed as beams **124** to an output lens array **126**. An output fiber array **128** is aligned with lens array **126** to receive and output optical signals **129**. Thus, lens array **126** couples beams **124** into the output fiber array **128**.

The rotatable positions or orientations of the individual mirror elements **12** of arrays **118** and **122** are, however, affected by environmental conditions such as temperature changes. As a result, once the positions of the mirror elements **12** are set, those intended positions may drift or change due (for example) to temperature variations, thereby adversely causing inefficient or unintended signal routing and associated power losses. A similar problem may be caused by mechanical fatigue and stress on the actuators used to control mirror position, and by electric charging effects on the actuators. These variations can result in conditions referred to as macro-drift, wherein all of the mirror elements in an array drift by an equal amount, and micro-drift, in which only some of the mirror element positions unintentionally change.

To detect such unwanted mirror drift in optical crossconnects in accordance with the present invention to compen-

sate for actual mirror positions, one or more monitoring devices **130**, **132** are included in the crossconnect system **100** shown in FIG. 2. The monitoring devices may be used to detect both macro-drift and micro-drift conditions of the MEMS mirror arrays **118**, **122**. For example, each monitoring device may be a camera or other imaging devices which operates independently of other cameras. Each camera is shown in FIG. 2 positioned outside of the optical path of the crossconnect (i.e. the path in which optical signal **116** travels through the crossconnect to fiber array **128**) and obtains an image of its respective MEMS array. Thus, camera **130** is focussed on MEMS array **118** and camera **132** is focussed on MEMS array **122**. The resulting images are then compared to reference images of mirror array positions stored, for example, in a controller block **500** containing a processor and a database (not shown) in a manner well-known to those having ordinary skill in the art. In the event that an unacceptable amount of drift is detected for the entire mirror array, feedback control signals can be generated by the control block **500** for adjusting the tilt angles to compensate for drift by applying appropriate voltages to the mirror actuators. If on the other hand only certain mirror elements need to be adjusted, these mirrors can be identified, through the aforementioned image comparison with a reference image, and then re-positioned by applying appropriate voltages to the desired actuators.

The monitoring system of FIG. 2 can also be employed in connection with a folded crossconnect configuration, as for example shown in FIG. 3, wherein a single input/output fiber array **312**, single MEMS mirror array **318**, and reflective surface element **330** comprise the folded configuration. A camera **340** positioned outside of the optical path **316** obtains an image **342** of the mirror elements in the array **318** for use in calculating and compensating for detected drift.

As an alternative or in addition to the use of cameras, device **130** (FIG. 2) may comprise one or more illuminators (not shown) for producing, for example, one or more infra-red beams **131**, **133** directed at mirror arrays **118**, **122** and devices **130**, **132** may comprise an infra-red detector for detecting the reflected infra-red beams. The illumination source may produce a test signal having a different wavelength from the signal wavelength or can be modulated to discriminate and distinguish it from the signal wavelength. The infrared beams **131**, **133** may be pencil beams for illuminating a single mirror element which may be designated as a reference element, such as element **16** in FIG. 1. The reflected infra-red signal will pass through the optical crossconnect for receipt by its respective infra-red detector. For example, for an infra-red test beam directed at a mirror element in array **118**, the test beam will be reflected and directed to detector **130**, and for an infrared beam directed at a mirror element in array **122**, the test beam will be received by detector **132**. Depending on the characteristics of the reflected and received infra-red beams—such as a reduction in beam power or intensity and/or a change of position on the detector at which the beam is received, etc.—macrodrift can be dynamically detected. For example, and as a result of a temperature change, drift may occur among all mirror elements in mirror arrays **118**, **122**. By measuring and detecting drift from a reference mirror element (e.g. mirror **16**), the mirror arrays can be adjusted to compensate for drift by generating appropriate feedback signals from control blocks **500** to be applied to mirror control actuators.

It will be appreciated that both devices **130**, **132** can operate as combined or dual-function source/receiver devices wherein each device produces a signal for receipt by

# Explore Litigation Insights

Docket Alarm provides insights to develop a more informed litigation strategy and the peace of mind of knowing you're on top of things.

## Real-Time Litigation Alerts



Keep your litigation team up-to-date with **real-time alerts** and advanced team management tools built for the enterprise, all while greatly reducing PACER spend.

Our comprehensive service means we can handle Federal, State, and Administrative courts across the country.

## Advanced Docket Research



With over 230 million records, Docket Alarm's cloud-native docket research platform finds what other services can't. Coverage includes Federal, State, plus PTAB, TTAB, ITC and NLRB decisions, all in one place.

Identify arguments that have been successful in the past with full text, pinpoint searching. Link to case law cited within any court document via Fastcase.

## Analytics At Your Fingertips



Learn what happened the last time a particular judge, opposing counsel or company faced cases similar to yours.

Advanced out-of-the-box PTAB and TTAB analytics are always at your fingertips.

## API

Docket Alarm offers a powerful API (application programming interface) to developers that want to integrate case filings into their apps.

## LAW FIRMS

Build custom dashboards for your attorneys and clients with live data direct from the court.

Automate many repetitive legal tasks like conflict checks, document management, and marketing.

## FINANCIAL INSTITUTIONS

Litigation and bankruptcy checks for companies and debtors.

## E-DISCOVERY AND LEGAL VENDORS

Sync your system to PACER to automate legal marketing.