



US005629790A

United States Patent [19]

[11] Patent Number: **5,629,790**

Neukermans et al.

[45] Date of Patent: **May 13, 1997**

[54] MICROMACHINED TORSIONAL SCANNER

[76] Inventors: **Armand P. Neukermans**, 3510 Arbutus Ave., Palo Alto, Calif. 94303; **Timothy G. Slater**, 1226-25th Ave., San Francisco, Calif. 94122

[21] Appl. No.: **139,397**

[22] Filed: **Oct. 18, 1993**

[51] Int. Cl.⁶ **G02B 26/08**

[52] U.S. Cl. **359/198; 359/199; 359/201; 359/202; 359/203; 359/214; 359/224; 250/234**

[58] Field of Search **359/196-199, 359/201-203, 212-214, 223-226, 230, 290-293; 250/230, 234; 310/15, 36, 40 MM**

[56] References Cited

U.S. PATENT DOCUMENTS

4,317,611	3/1982	Petersen .	
4,468,282	8/1984	Neukermans	156/633
4,732,440	3/1988	Gadhok .	
4,942,766	7/1990	Greenwood et al.	250/201.1
5,016,072	5/1991	Greiff	357/26
5,202,785	4/1993	Nelson	359/214

OTHER PUBLICATIONS

Diem, B. et al., "SOI (SIMOX) As a Substrate for Surface Micro-machining of Single Crystalline Silicon Sensors and Actuators", The 7th International Conference on Solid-State Sensors and Actuators, (1993), pp. 233-236.

K. Petersen, "Silicon Torsional Mirror", Proceedings of the IEEE vol. 70, No. 5, May 1982, p. 61.

B. Wagner et al., "Electromagnetic Microactuators with Multiple Degrees of Freedom", International Conference on Solid-State Sensors and Actuators, Digest of Technical Papers, (1991), (IEEE Cat. No. 91CH2817-5) pp. 614-617.

V.P. Jaecklin et al., "Mechanical and Optical Properties of Surface Micromachined Torsional Mirrors in Silicon, Polysilicon and Aluminum", The 7th International Conference on Solid-State Sensors and Actuators (1993), pp. 958-961.

R.N. Kleiman et al., "Single-crystal silicon high-Q torsional oscillators", Rev.Sci.Instrum. 56(11), Nov. 1985, pp. 2088-2091.

R.A. Buser et al., "Very High Q-factor Resonators in Monocrystalline Silicon", Sensors and Actuators, A21-A23 (1990), pp. 323-327.

Breng, U. et al., "Electrostatic micromechanic actuators", Journal of Micromechanics and Microengineering 2 (1992) 256-261. no month.

Pfann, W. G. et al., "Semiconducting Stress Transducers Utilizing the Transverse and Shear Piezoresistance Effects", Journal of Applied Physics, vol. 32, No. 10, Oct. 1961, pp. 2008-2016.

Primary Examiner—James Phan

Attorney, Agent, or Firm—Donald E. Schreiber

[57] ABSTRACT

A frequency-locked torsional scanner of the type having a micromachined mirror formed on a surface of a silicon wafer section supported within a larger wafer section by a pair of opposed torsion bars. The principal vibrational frequency of the mirror is selected to be at least 20% higher than other modes of vibration. To prevent breakage, the torsion bars are hardened by conversion of at least a surface layer to silicon carbide or nitride. A pair of scanners with orthogonal torsion bars may be mounted in a vacuum enclosure for two-dimensional scanning at different rates suitable for television display. In alternate embodiments, a detector and a scanner may be built on a plate on the same supported wafer section or two scanners may be independently supported or one scanner and one detector may be independently supported as two plates. The mirror may be driven electrostatically, magnetically, or by both methods.

41 Claims, 11 Drawing Sheets

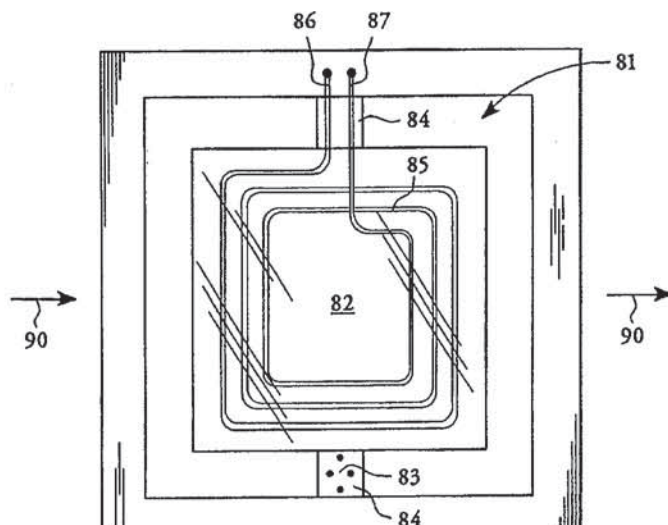

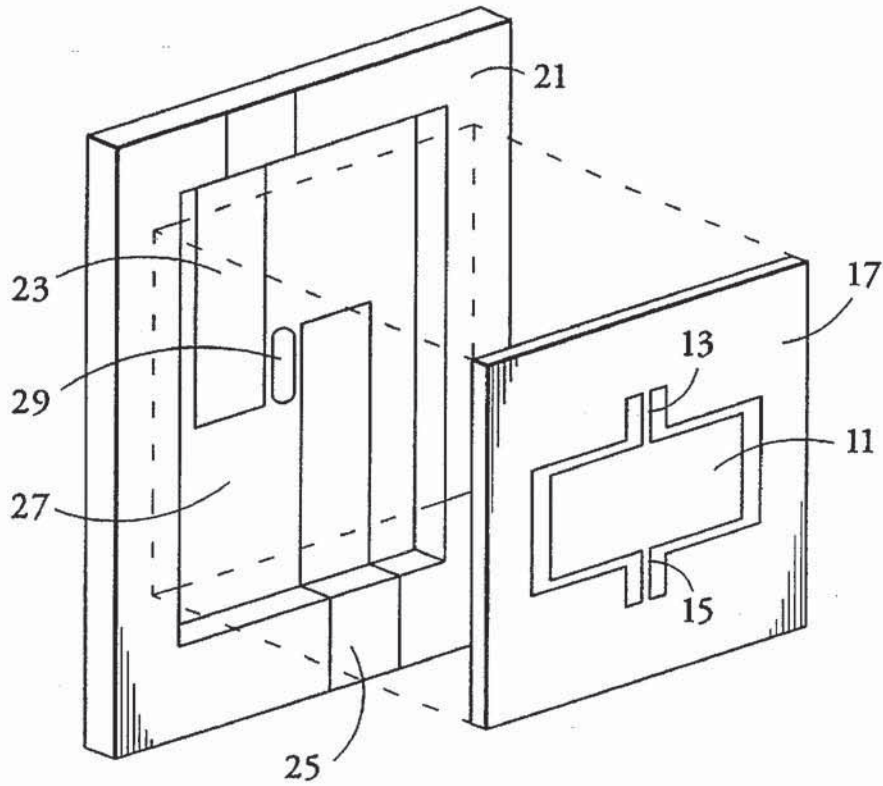

FIG. 1
(PRIOR ART)

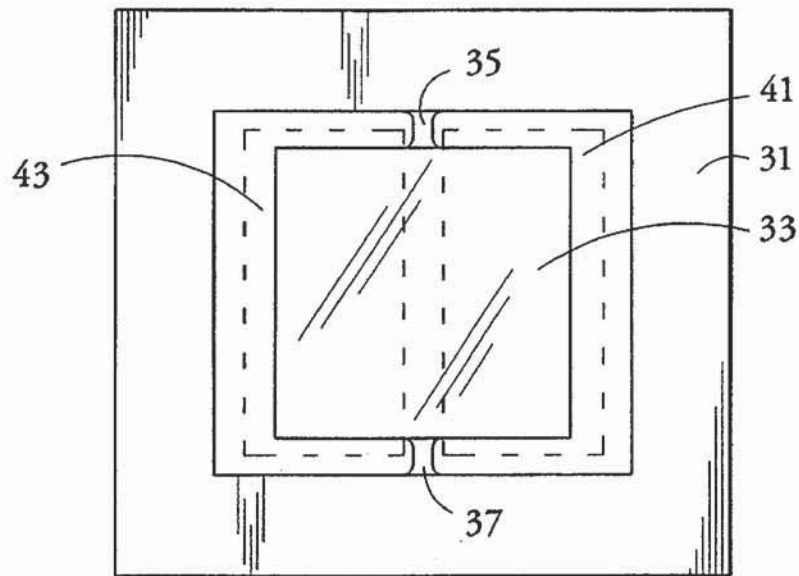

FIG. 2

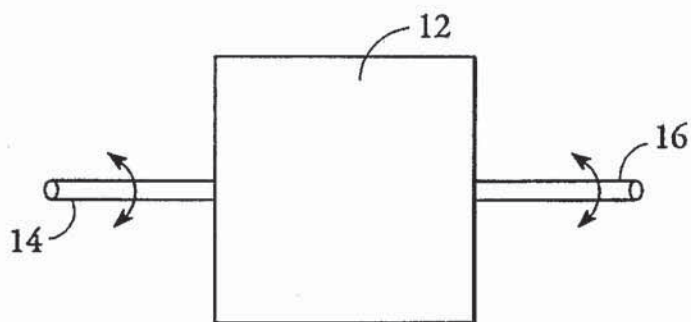

FIG. 1a

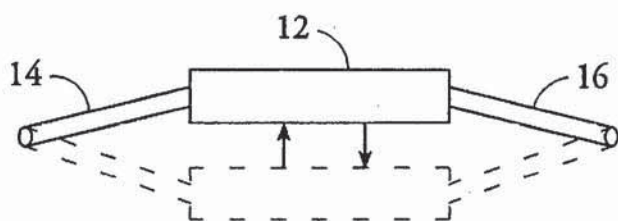

FIG. 1b

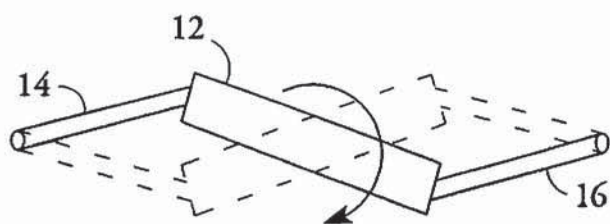

FIG. 1c

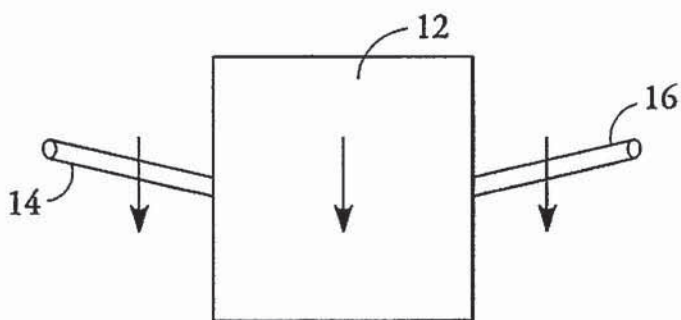

FIG. 1d

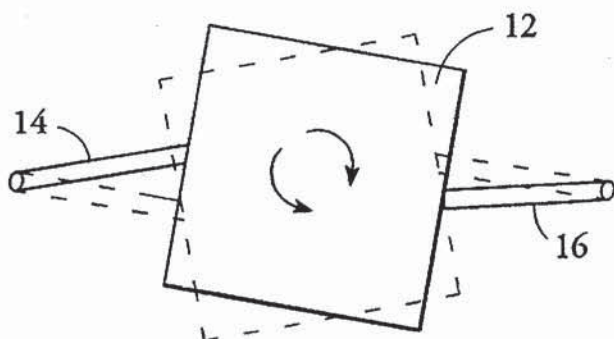

FIG. 1e

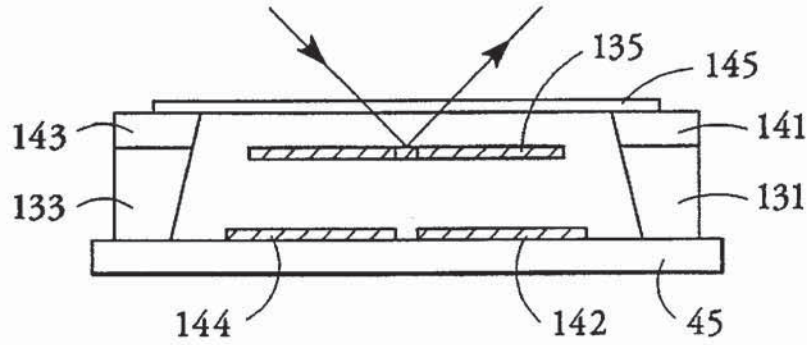

FIG. 2a

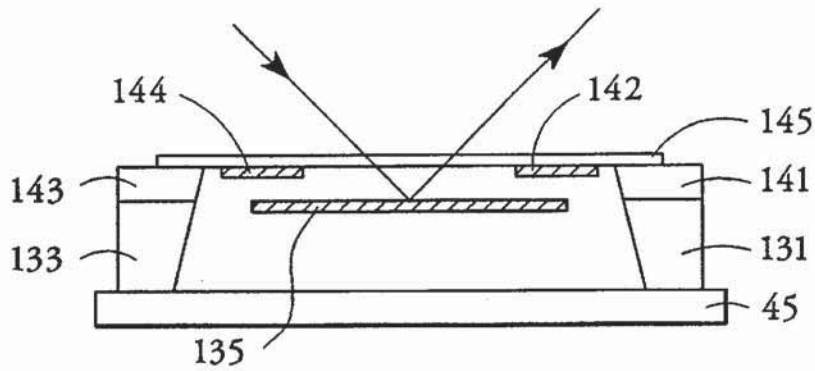

FIG. 2b

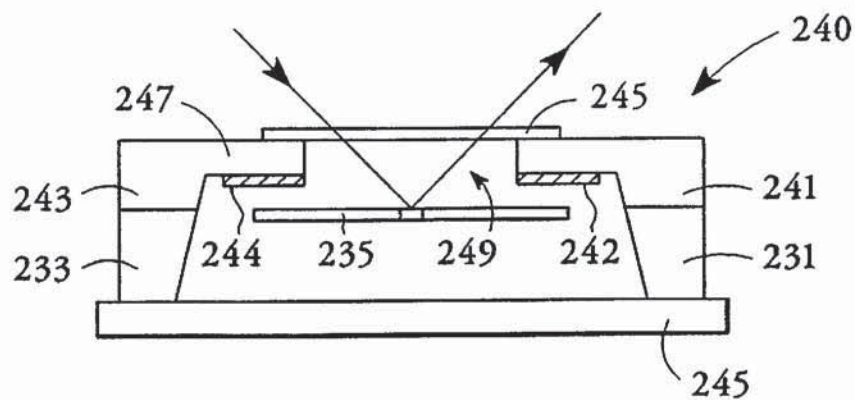

FIG. 2c

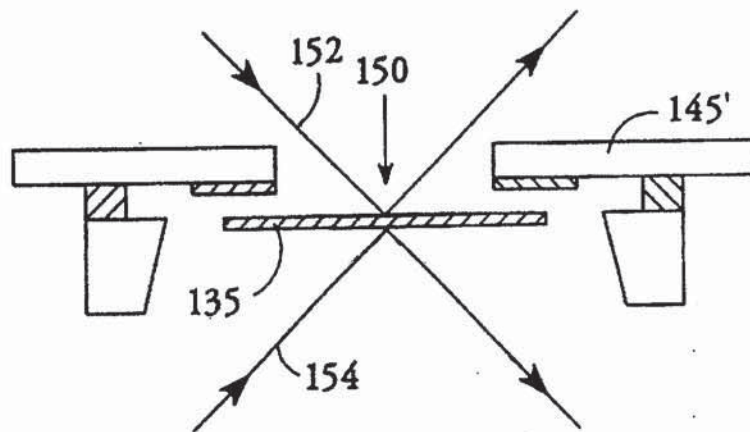

FIG. 2d

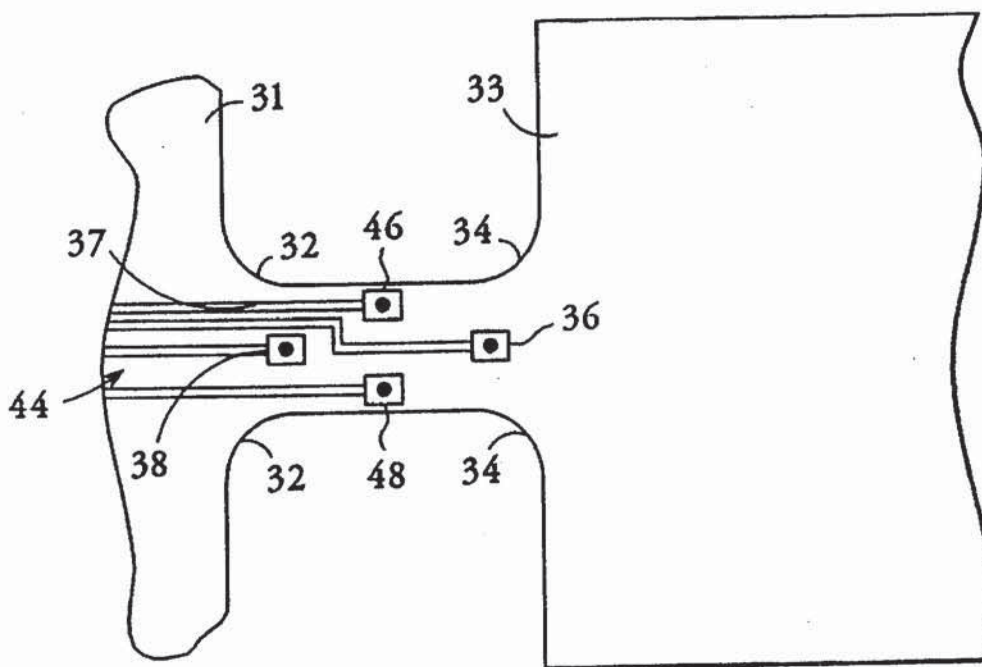

FIG. 3

Explore Litigation Insights

Docket Alarm provides insights to develop a more informed litigation strategy and the peace of mind of knowing you're on top of things.

Real-Time Litigation Alerts



Keep your litigation team up-to-date with **real-time alerts** and advanced team management tools built for the enterprise, all while greatly reducing PACER spend.

Our comprehensive service means we can handle Federal, State, and Administrative courts across the country.

Advanced Docket Research



With over 230 million records, Docket Alarm's cloud-native docket research platform finds what other services can't. Coverage includes Federal, State, plus PTAB, TTAB, ITC and NLRB decisions, all in one place.

Identify arguments that have been successful in the past with full text, pinpoint searching. Link to case law cited within any court document via Fastcase.

Analytics At Your Fingertips



Learn what happened the last time a particular judge, opposing counsel or company faced cases similar to yours.

Advanced out-of-the-box PTAB and TTAB analytics are always at your fingertips.

API

Docket Alarm offers a powerful API (application programming interface) to developers that want to integrate case filings into their apps.

LAW FIRMS

Build custom dashboards for your attorneys and clients with live data direct from the court.

Automate many repetitive legal tasks like conflict checks, document management, and marketing.

FINANCIAL INSTITUTIONS

Litigation and bankruptcy checks for companies and debtors.

E-DISCOVERY AND LEGAL VENDORS

Sync your system to PACER to automate legal marketing.