

IN THE UNITED STATES DISTRICT COURT  
FOR THE WESTERN DISTRICT OF TEXAS  
AUSTIN DIVISION

|                           |   |                                |
|---------------------------|---|--------------------------------|
| CROSSROADS SYSTEMS, INC., | § |                                |
|                           | § |                                |
| Plaintiff,                | § |                                |
|                           | § | CIVIL ACTION NO. 1:14-cv-00149 |
| v.                        | § |                                |
|                           | § | JURY DEMANDED                  |
| NETAPP, INC.,             | § |                                |
|                           | § |                                |
| Defendant.                | § |                                |

**PLAINTIFF CROSSROADS SYSTEMS, INC.’S  
FIRST AMENDED COMPLAINT FOR PATENT INFRINGEMENT**

**THE PARTIES**

1. Pursuant to Federal Rule of Civil Procedure 15(a)(1)(B), Plaintiff Crossroads Systems, Inc. (“Crossroads”) hereby submits its First Amended Complaint for Patent Infringement as a matter of course within 21 days after service of NetApp, Inc.’s Answer and Affirmative Defenses (Dkt. No. 21).

2. Crossroads is a corporation incorporated under the laws of the State of Delaware and has its principal place of business at 11000 North MoPac Expressway, Austin, Texas 78759.

3. Upon information and belief, Defendant NetApp, Inc. (“Defendant” or “NetApp”) is a California corporation with a principal place of business of 495 East Java Drive, Sunnyvale, California 94089.

**JURISDICTION AND VENUE**

3. This action arises under the laws of the United States, more specifically under 35 U.S.C. § 100, *et seq.* Subject matter jurisdiction is proper in this Court pursuant to 28 U.S.C. §§ 1331 and 1338.

4. Personal jurisdiction and venue are proper in this district under 28 U.S.C. §§ 1391 and 1400(b). Upon information and belief, Defendant NetApp has established minimum contacts with this forum such that the exercise of jurisdiction over Defendant would not offend traditional notions of fair play and substantial justice.

5. This Court has personal jurisdiction over NetApp. Upon information and belief, NetApp regularly conducts business in the State of Texas and in this judicial district and is subject to the jurisdiction of this Court. Upon information and belief, NetApp has been doing business in Texas and this judicial district by distributing, marketing, selling and/or offering for sale its products, including, but not limited to, products that practice the subject matter claimed in United States Patent Nos. 6,425,035 (“the ’035 Patent”), 7,934,041 (“the ’041 Patent”), 7,051,147 (“the ’147 Patent”), and 7,987,311 (“the ’311 Patent”) (collectively “the Patents-In-Suit”), and/or regularly doing or soliciting business and/or engaging in other persistent courses of conduct in and/or directed to Texas and this judicial district.

**COUNT 1: INFRINGEMENT OF U.S. PATENT NO. 6,425,035**

6. Crossroads incorporates by reference the allegations set forth in the preceding paragraphs.

7. On July 23, 2002, the ’035 Patent was duly and legally issued. A true and correct copy of the ’035 Patent is attached hereto as Exhibit A. Crossroads is the assignee and the owner of all right, title, and interest in and to the ’035 Patent. The ’035 Patent is entitled to a presumption of validity.

8. On information and belief, Defendant has directly infringed the ’035 Patent. On information and belief, Defendant continues to directly infringe the ’035 Patent.

9. Specifically, on information and belief, Defendant has directly infringed the '035 Patent by making, using, offering for sale, selling and/or importing into the United States certain of its products including at least the following: NetApp E5400 Series Storage Arrays (including but not limited to the E5460, E5424, and E5412), E5500 Series Storage Arrays with FC, iSCSI and InfiniBand interfaces (including but not limited to the E5560, E5524, and E5512), E2700 Storage Systems with FC and iSCSI interfaces (including but not limited to the E2760, E2724, E2712), E2600 Storage Systems with FC and iSCSI interfaces (including but not limited to the E2600-60, E2600-24, E2600-12), EF550 Flash Arrays with FC, iSCSI and InfiniBand Host interfaces, EF540 Flash Arrays, FAS2200 Series (including but not limited to FAS2220 and FAS2240), FAS3200 Series (including but not limited to FAS3270, FAS3250, FAS3240, FAS3220, FAS3210), FAS6200 Series (including but not limited to FAS6210, FAS6220, FAS6240, FAS6250, FAS6280, FAS6290), FAS8000 Series (including but not limited to FAS8060, FAS8040, FAS8020), V3200 Series Storage Controllers (including but not limited to V3220, V3240, V3250, V3270), V6200 Series Storage Controllers (including but not limited to V6210, V6220, V6240, V6250, V6280, V6290) and the Data ONTAP Operating System (including but not limited to Data ONTAP 8.2), hereinafter "the Accused Products".

10. Further, on information and belief, Defendant has been and now is indirectly infringing by way of inducing infringement of the '035 Patent with knowledge of the '035 Patent by making, offering for sale, selling, importing into the United States, marketing, supporting, providing product instruction and/or advertising certain of its products, including the Accused Products, and Defendant knew that its actions were inducing end users to infringe the '035 Patent.

11. Further, on information and belief, Defendant has been and now is indirectly infringing by way of contributing to the infringement by end users of the '035 Patent by selling, offering to sell and/or importing into the United States components, including the Accused Products, knowing the components to be especially made or especially adapted for use in the infringement of the '035 Patent. Such components are not a staple article or commodity of commerce suitable for substantial non-infringing uses.

12. Defendant has been on constructive and/or actual notice of the '035 Patent since at least as early as October 2002, and Defendant has not ceased its infringing activities. The infringement of the '035 Patent by Defendant has been and continues to be willful and deliberate.

13. Crossroads has been irreparably harmed by Defendant's acts of infringement of the '035 Patent, and will continue to be harmed unless and until Defendant's acts of infringement are enjoined and restrained by order of this Court.

14. As a result of the acts of infringement of the '035 Patent by Defendant, Crossroads has suffered and will continue to suffer damages in an amount to be proven at trial.

**COUNT 2: INFRINGEMENT OF U.S. PATENT NO. 7,934,041**

15. Crossroads incorporates by reference the allegations set forth in the preceding paragraphs.

16. On April 26, 2011, the '041 Patent was duly and legally issued. A true and correct copy of the '041 Patent is attached hereto as Exhibit B. Crossroads is the assignee and the owner of all right, title, and interest in and to the '041 Patent. The '041 Patent is entitled to a presumption of validity.

17. On information and belief, Defendant has directly infringed the '041 Patent. On information and belief, Defendant continues to directly infringe the '041 Patent.



18. Specifically, on information and belief, Defendant has directly infringed the '041 Patent by making, using, offering for sale, selling and/or importing into the United States certain of its products including at least the Accused Products.

19. Further, upon information and belief, Defendant has been and now is indirectly infringing by way of inducing infringement of the '041 Patent with knowledge of the '041 Patent by making, offering for sale, selling, importing into the United States, marketing, supporting, providing product instruction and/or advertising certain of its products, including the Accused Products, and Defendant knew that its actions were inducing end users to infringe the '041 Patent.

20. Further, upon information and belief, Defendant has been and now is indirectly infringing by way of contributing to the infringement by end users of the '041 Patent by selling, offering to sell and/or importing into the United States components, including the Accused Products, knowing the components to be especially made or especially adapted for use in the infringement of the '041 Patent. Such components are not a staple article or commodity of commerce suitable for substantial non-infringing uses.

21. Defendant has been on constructive and/or actual notice of the '041 Patent since at least as early as May 2011, and Defendant has not ceased its infringing activities. The infringement of the '041 Patent by Defendant has been and continues to be willful and deliberate.

22. Crossroads has been irreparably harmed by Defendant's acts of infringement of the '041 Patent, and will continue to be harmed unless and until Defendant's acts of infringement are enjoined and restrained by order of this Court.

23. As a result of the acts of infringement of the '041 Patent by Defendant, Crossroads has suffered and will continue to suffer damages in an amount to be proven at trial.

**COUNT 3: INFRINGEMENT OF U.S. PATENT NO. 7,051,147**

24. Crossroads incorporates by reference the allegations set forth in the preceding paragraphs.

25. On May 23, 2006, the '147 Patent was duly and legally issued. A true and correct copy of the '147 Patent is attached hereto as Exhibit C. Crossroads is the assignee and the owner of all right, title, and interest in and to the '147 Patent. The '147 Patent is entitled to a presumption of validity.

26. On information and belief, Defendant has directly infringed the '147 Patent. On information and belief, Defendant continues to directly infringe the '147 Patent.

27. Specifically, on information and belief, Defendant has directly infringed the '147 Patent by making, using, offering for sale, selling and/or importing into the United States certain of its products including at least the V3200 Series Storage Controllers (including but not limited to V3220, V3240, V3250, V3270) and V6200 Series Storage Controllers (including but not limited to V6210, V6220, V6240, V6250, V6280 and V6290) and the Data ONTAP operating system, hereinafter "the Accused Fibre-to-Fibre Products".

28. Further, upon information and belief, Defendant has been and now is indirectly infringing by way of inducing infringement of the '147 Patent with knowledge of the '147 Patent by making, offering for sale, selling, importing into the United States, marketing, supporting, providing product instruction and/or advertising certain of its products, including the Accused Fibre-to-Fibre Products, and Defendant knew that its actions were inducing end users to infringe the '147 Patent.

29. Further, upon information and belief, Defendant has been and now is indirectly infringing by way of contributing to the infringement by end users of the '147 Patent by selling,

offering to sell and/or importing into the United States components, including the Accused Fibre-to-Fibre Products, knowing the components to be especially made or especially adapted for use in the infringement of the '147 Patent. Such components are not a staple article or commodity of commerce suitable for substantial non-infringing uses.

30. Defendant has been on constructive and/or actual notice of the '147 Patent since at least as early as August 2006, and Defendant has not ceased its infringing activities. The infringement of the '147 Patent by Defendant has been and continues to be willful and deliberate.

31. Crossroads has been irreparably harmed by Defendant's acts of infringement of the '147 Patent, and will continue to be harmed unless and until Defendant's acts of infringement are enjoined and restrained by order of this Court.

32. As a result of the acts of infringement of the '147 Patent by Defendant, Crossroads has suffered and will continue to suffer damages in an amount to be proven at trial.

**COUNT 4: INFRINGEMENT OF U.S. PATENT NO. 7,987,311**

33. Crossroads incorporates by reference the allegations set forth in the preceding paragraphs.

34. On July 26, 2011, the '311 Patent was duly and legally issued. A true and correct copy of the '311 Patent is attached hereto as Exhibit D. Crossroads is the assignee and the owner of all right, title, and interest in and to the '311 Patent. The '311 Patent is entitled to a presumption of validity.

35. On information and belief, Defendant has directly infringed the '311 Patent. On information and belief, Defendant continues to directly infringe the '311 Patent.

36. Specifically, on information and belief, Defendant has directly infringed the '311 Patent by making, using, offering for sale, selling and/or importing into the United States certain of its products including at least the Accused Products.

37. Further, on information and belief, Defendant has been and now is indirectly infringing by way of inducing infringement of the '311 Patent with knowledge of the '311 Patent by making, offering for sale, selling, importing into the United States, marketing, supporting, providing product instruction and/or advertising certain of its products, including the Accused Products, and Defendant knew that its actions were inducing end users to infringe the '311 Patent.

38. Further, on information and belief, Defendant has been and now is indirectly infringing by way of contributing to the infringement by end users of the '311 Patent by selling, offering to sell and/or importing into the United States components, including the Accused Products, knowing the components to be especially made or especially adapted for use in the infringement of the '311 Patent. Such components are not a staple article or commodity of commerce suitable for substantial non-infringing uses.

39. On information and belief, Defendant has been on constructive and/or actual notice of the '311 Patent. Thus, the infringement of the '311 Patent by Defendant has been and continues to be willful and deliberate.

40. Crossroads has been irreparably harmed by Defendant's acts of infringement of the '311 Patent, and will continue to be harmed unless and until Defendant's acts of infringement are enjoined and restrained by order of this Court.

41. As a result of the acts of infringement of the '311 Patent by Defendant, Crossroads has suffered and will continue to suffer damages in an amount to be proven at trial.

**DEMAND FOR JURY TRIAL**

Crossroads hereby demands a trial by jury on all issues.

**PRAYER FOR RELIEF**

WHEREFORE, Crossroads requests this Court enter judgment as follows:

- A. That Defendant has infringed the '035 Patent;
- B. That such infringement of the '035 Patent by Defendant has been willful;
- C. That Defendant accounts for and pays to Crossroads all damages caused by the infringement of the '035 Patent;
- D. That Crossroads receive enhanced damages from Defendant in the form of treble damages, pursuant to 35 U.S.C. § 284 based on Defendant's willful infringement of the '035 Patent;
- E. That Crossroads be granted pre-judgment and post-judgment interest on the damages caused to it by reason of Defendant's infringement of the '035 Patent, including pre-judgment and post-judgment interest on any enhanced damages or attorneys' fees award;
- F. That Defendant has infringed the '041 Patent;
- G. That such infringement of the '041 Patent by Defendant has been willful;
- H. That Defendant accounts for and pays to Crossroads all damages caused by the infringement of the '041 Patent;
- I. That Crossroads receive enhanced damages from Defendant in the form of treble damages, pursuant to 35 U.S.C. § 284 based on Defendant's willful infringement of the '041 Patent;

- J. That Crossroads be granted pre-judgment and post-judgment interest on the damages caused to it by reason of Defendant's infringement of the '041 Patent, including pre-judgment and post-judgment interest on any enhanced damages or attorneys' fees award;
- K. That Defendant has infringed the '147 Patent;
- L. That such infringement of the '147 Patent by Defendant has been willful;
- M. That Defendant accounts for and pays to Crossroads all damages caused by the infringement of the '147 Patent;
- N. That Crossroads receive enhanced damages from Defendant in the form of treble damages, pursuant to 35 U.S.C. § 284 based on Defendant's willful infringement of the '147 Patent;
- O. That Crossroads be granted pre-judgment and post-judgment interest on the damages caused to it by reason of Defendant's infringement of the '147 Patent, including pre-judgment and post-judgment interest on any enhanced damages or attorneys' fees award;
- P. That Defendant has infringed the '311 Patent;
- Q. That such infringement of the '311 Patent by Defendant has been willful;
- R. That Defendant accounts for and pays to Crossroads all damages caused by the infringement of the '311 Patent;
- S. That Crossroads receive enhanced damages from Defendant in the form of treble damages, pursuant to 35 U.S.C. § 284 based on Defendant's willful infringement of the '311 Patent;

- T. That Crossroads be granted pre-judgment and post-judgment interest on the damages caused to it by reason of Defendant's infringement of the '311 Patent, including pre-judgment and post-judgment interest on any enhanced damages or attorneys' fees award;
- U. That Defendant pay Crossroads all of Crossroads' reasonable attorneys' fees and expenses;
- V. That costs be awarded to Crossroads;
- W. That Defendant, its agents, employees, representatives, successors and assigns, and those acting in privity or in concert with it, be preliminarily and permanently enjoined from further infringement of the '035 Patent;
- X. That Defendant, its agents, employees, representatives, successors and assigns, and those acting in privity or in concert with it, be preliminarily and permanently enjoined from further infringement of the '041 Patent;
- Y. That Defendant, its agents, employees, representatives, successors and assigns, and those acting in privity or in concert with it, be preliminarily and permanently enjoined from further infringement of the '147 Patent;
- Z. That Defendant, its agents, employees, representatives, successors and assigns, and those acting in privity or in concert with it, be preliminarily and permanently enjoined from further infringement of the '311 Patent;
- AA. That this is an exceptional case under 35 U.S.C. § 285; and
- BB. That Crossroads be granted such other and further relief as the Court may deem just and proper under the circumstances.

Dated: April 15, 2014

Respectfully submitted,

By: /s/ Susan K. Knoll  
Steven Sprinkle  
Texas Bar No. 00794962  
Elizabeth J. Brown Fore  
Texas Bar No. 24001795  
Sprinkle IP Law Group, PC  
1301 W. 25<sup>th</sup> Street, Suite 408  
Austin, Texas 78705  
Tel: 512-637-9220  
Fax: 512-371-9088  
ssprinkle@sprinklelaw.com  
ebrownfore@sprinklelaw.com

Susan K. Knoll  
Texas Bar No. 11616900  
Russell T. Wong  
Texas Bar No. 21884235  
James H. Hall  
Texas Bar No. 24041040  
Stephen D. Zinda  
Texas Bar No. 24084147  
WONG, CABELLO, LUTSCH,  
RUTHERFORD & BRUCCULERI, L.L.P.  
20333 SH 249, Suite 600  
Houston, TX 77070  
Tel: 832-446-2400  
Fax: 832-446-2424  
sknoll@counselip.com  
rwong@counselip.com  
jhall@counselip.com  
szinda@counselip.com

*ATTORNEYS FOR PLAINTIFF  
CROSSROADS SYSTEMS, INC.*

**CERTIFICATE OF SERVICE**

I certify that on April 15, 2014, I electronically filed the foregoing with the Clerk of Court using the CM/ECF system, which will send notification of such filing to all CM/ECF participants.

/s/ Lynn Marlin  
Lynn Marlin



# **EXHIBIT A**

(12) **United States Patent**  
**Hoese et al.**

(10) **Patent No.:** **US 6,425,035 B2**  
 (45) **Date of Patent:** **\*Jul. 23, 2002**

- (54) **STORAGE ROUTER AND METHOD FOR PROVIDING VIRTUAL LOCAL STORAGE**
  - (75) Inventors: **Geoffrey B. Hoese**, Austin; **Jeffrey T. Russell**, Cibolo, both of TX (US)
  - (73) Assignee: **Crossroads Systems, Inc.**, Austin, TX (US)
  - (\* ) Notice: Subject to any disclaimer, the term of this patent is extended or adjusted under 35 U.S.C. 154(b) by 0 days.
- This patent is subject to a terminal disclaimer.

|              |   |         |                  |         |
|--------------|---|---------|------------------|---------|
| 5,935,260 A  | * | 8/1999  | Ofer             | 714/42  |
| 5,941,972 A  | * | 8/1999  | Hoese et al.     | 710/129 |
| 5,959,994 A  | * | 9/1999  | Boggs et al.     | 370/399 |
| 6,041,381 A  | * | 3/2000  | Hoese            | 710/129 |
| 6,055,603 A  | * | 4/2000  | Ofer et al.      | 711/113 |
| 6,065,087 A  | * | 5/2000  | Keaveny et al.   | 710/129 |
| 6,075,863 A  | * | 6/2000  | Krishnan et al.  | 380/49  |
| 6,098,149 A  | * | 8/2000  | Ofer et al.      | 711/112 |
| 6,118,766 A  | * | 9/2000  | Akers            | 370/249 |
| 6,148,004 A  | * | 11/2000 | Nelson et al.    | 370/463 |
| 6,185,203 B1 | * | 2/2001  | Berman           | 370/351 |
| 6,209,023 B1 | * | 3/2001  | Dimitroff et al. | 709/211 |
| 6,230,218 B1 | * | 5/2001  | Caspers et al.   | 710/20  |
| 6,341,315 B1 | * | 1/2002  | Arroyo et al.    | 709/230 |
| 6,343,324 B1 | * | 1/2002  | Hubis et al.     | 709/229 |

\* cited by examiner

(21) Appl. No.: **09/965,335**

(22) Filed: **Sep. 27, 2001**

*Primary Examiner*—Christopher B. Shin

(74) *Attorney, Agent, or Firm*—Gray Cary Ware & Friedrich LLP

**Related U.S. Application Data**

- (63) Continuation of application No. 09/354,682, filed on Jul. 15, 1999, which is a continuation of application No. 09/001,799, filed on Dec. 31, 1997, now Pat. No. 5,941,972.
- (51) **Int. Cl.**<sup>7</sup> ..... **G06F 13/00**
- (52) **U.S. Cl.** ..... **710/129; 710/128; 710/8; 710/36; 710/105**
- (58) **Field of Search** ..... **710/1-5, 8-13, 710/36-38, 105, 100-101, 126-131; 711/100, 112, 113; 714/42**

**References Cited**

**U.S. PATENT DOCUMENTS**

|             |   |         |                 |         |
|-------------|---|---------|-----------------|---------|
| 5,748,924 A | * | 5/1998  | Llorens et al.  | 710/129 |
| 5,768,623 A | * | 6/1998  | Judd et al.     | 710/37  |
| 5,809,328 A | * | 9/1998  | Nogales et al.  | 710/5   |
| 5,812,754 A | * | 9/1998  | Lui et al.      | 714/6   |
| 5,835,496 A | * | 11/1998 | Yeung et al.    | 370/514 |
| 5,848,251 A | * | 12/1998 | Lomelino et al. | 710/129 |

(57) **ABSTRACT**

A storage router (56) and storage network (50) provide virtual local storage on remote SCSI storage devices (60, 62, 64) to Fiber Channel devices. A plurality of Fiber Channel devices, such as workstations (58), are connected to a Fiber Channel transport medium (52), and a plurality of SCSI storage devices (60, 62, 64) are connected to a SCSI bus transport medium (54). The storage router (56) interfaces between the Fibre Channel transport medium (52) and the SCSI bus transport medium (54). The storage router (56) maps between the workstations (58) and the SCSI storage devices (60, 62, 64) and implements access controls for storage space on the SCSI storage devices (60, 62, 64). The storage router (56) then allows access from the workstations (58) to the SCSI storage devices (60, 62, 64) using native low level, block protocol in accordance with the mapping and the access controls.

**14 Claims, 2 Drawing Sheets**

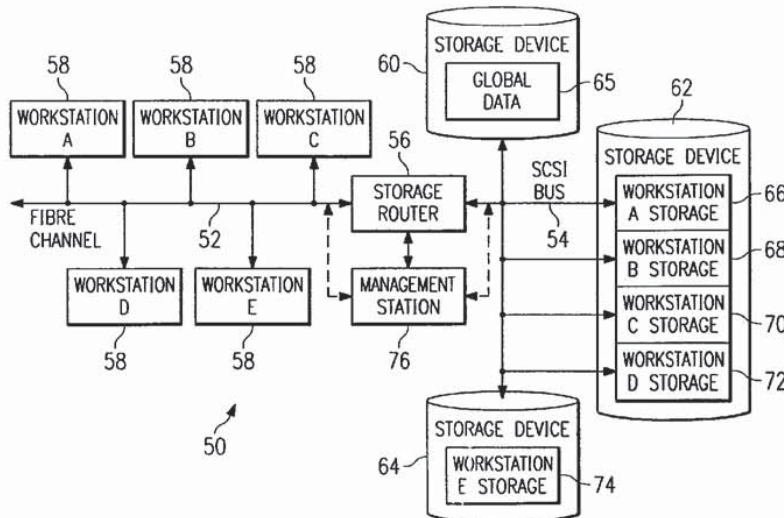

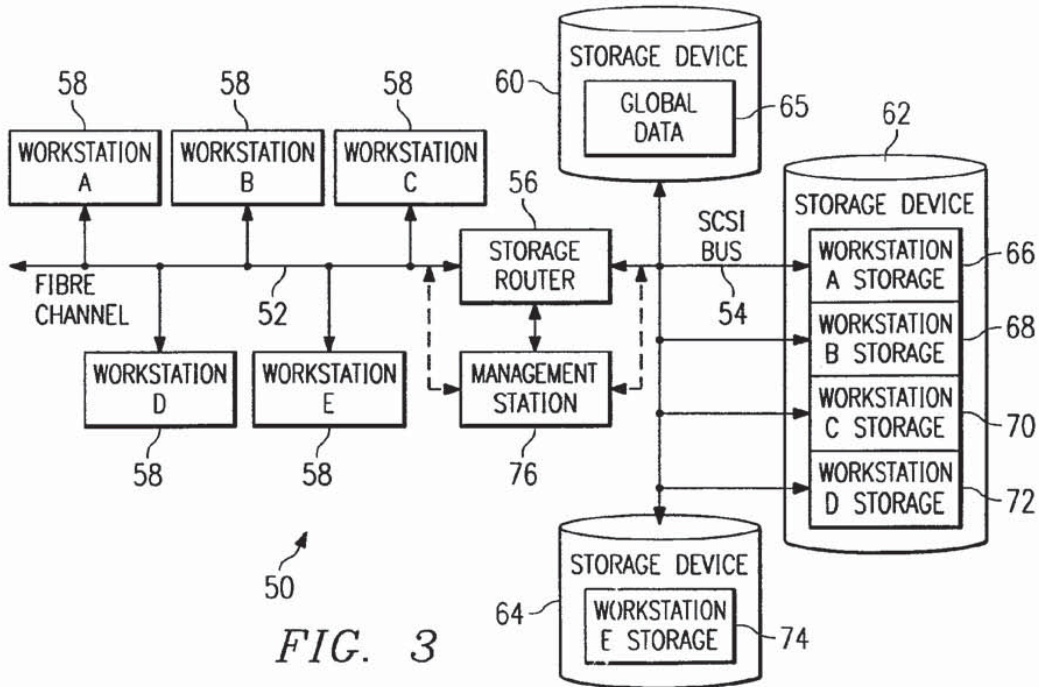
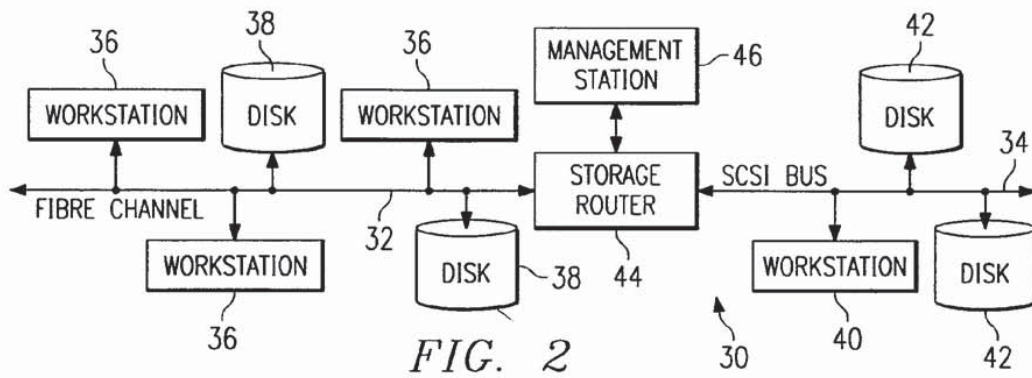
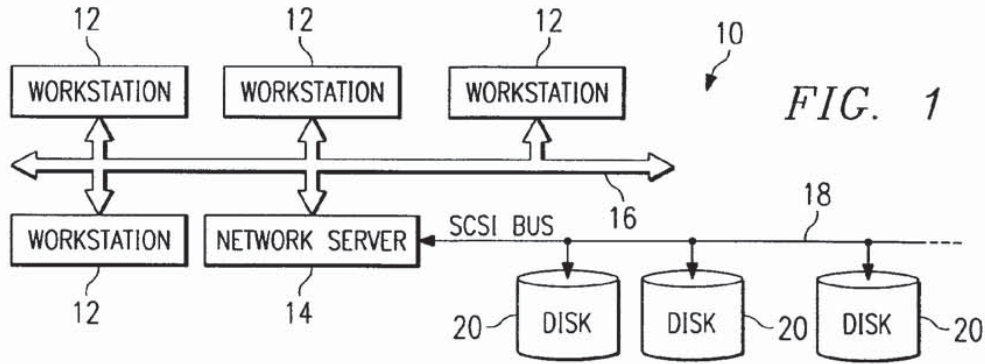

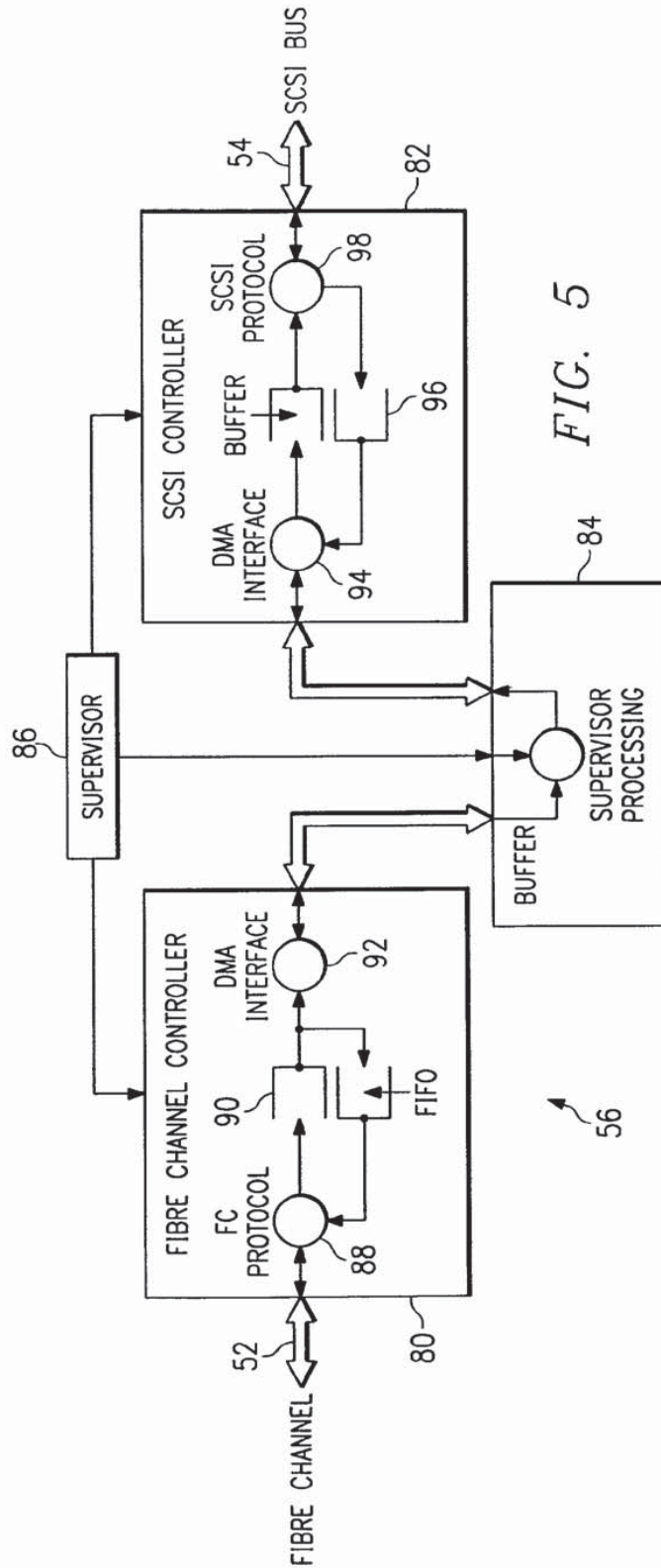
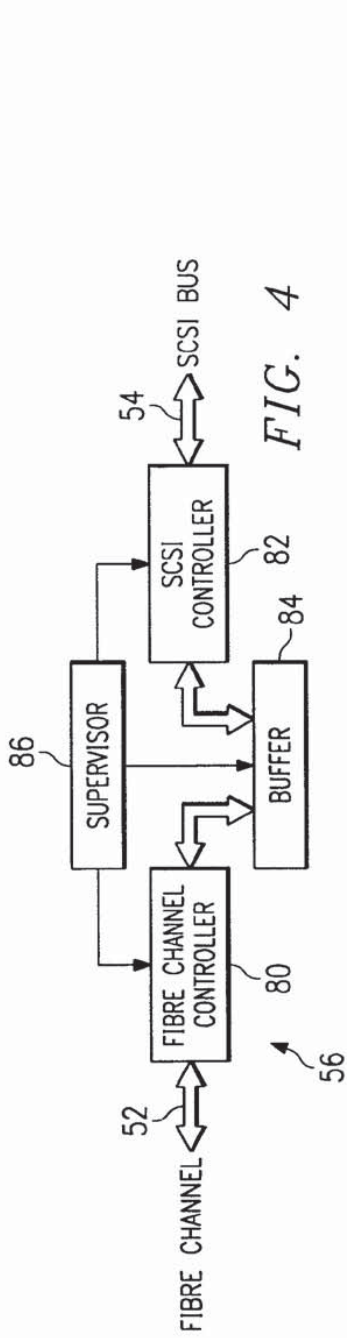



US 6,425,035 B2

1

**STORAGE ROUTER AND METHOD FOR PROVIDING VIRTUAL LOCAL STORAGE****RELATED APPLICATIONS**

This application claims the benefit of the filing date of U.S. patent application Ser. No. 09/354,682 by inventors Geoffrey B. Hoese and Jeffrey T. Russell, entitled "Storage Router and Method for Providing Virtual Local Storage" filed on Jul. 15, 1999, which is a continuation of U.S. patent application Ser. No. 091001,799, filed on Dec. 31, 1997, now U.S. Pat. No. 5,941,972, and hereby incorporates these applications by reference in their entireties as if they had been fully set forth herein.

**TECHNICAL FIELD OF THE INVENTION**

This invention relates in general to network storage devices, and more particularly to a storage router and method for providing virtual local storage on remote SCSI storage devices to Fiber Channel devices.

**BACKGROUND OF THE INVENTION**

Typical storage transport mediums provide for a relatively small number of devices to be attached over relatively short distances. One such transport medium is a Small Computer System Interface (SCSI) protocol, the structure and operation of which is generally well known as is described, for example, in the SCSI-1, SCSI-2 and SCSI-3 specifications. High speed serial interconnects provide enhanced capability to attach a large number of high speed devices to a common storage transport medium over large distances. One such serial interconnect is Fibre Channel, the structure and operation of which is described, for example, in Fiber Channel Physical and Signaling Interface (FC-PH), ANSI X3.230 Fiber Channel Arbitrated Loop (FC-AL), and ANSI X3.272 Fiber Channel Private Loop Direct Attach (FC-PLDA).

Conventional computing devices, such as computer workstations, generally access storage locally or through network interconnects. Local storage typically consists of a disk drive, tape drive, CD-ROM drive or other storage device contained within, or locally connected to the workstation. The workstation provides a file system structure, that includes security controls, with access to the local storage device through native low level, block protocols. These protocols map directly to the mechanisms used by the storage device and consist of data requests without security controls. Network interconnects typically provide access for a large number of computing devices to data storage on a remote network server. The remote network server provides file system structure, access control, and other miscellaneous capabilities that include the network interface. Access to data through the network server is through network protocols that the server must translate into low level requests to the storage device. A workstation with access to the server storage must translate its file system protocols into network protocols that are used to communicate with the server. Consequently, from the perspective of a workstation, or other computing device, seeking to access such server data, the access is much slower than access to data on a local storage device.

**SUMMARY OF THE INVENTION**

In accordance with the present invention, a storage router and method for providing virtual local storage on remote SCSI storage devices to Fiber Channel devices are disclosed that provide advantages over conventional network storage devices and methods.

2

According to one aspect of the present invention, a storage router and storage network provide virtual local storage on remote SCSI storage devices to Fiber Channel devices. A plurality of Fiber Channel devices, such as workstations, are connected to a Fiber Channel transport medium, and a plurality of SCSI storage devices are connected to a SCSI bus transport medium. The storage router interfaces between the Fiber Channel transport medium and the SCSI bus transport medium. The storage router maps between the workstations and the SCSI storage devices and implements access controls for storage space on the SCSI storage devices. The storage router then allows access from the workstations to the SCSI storage devices using native low level, block protocol in accordance with the mapping and the access controls.

According to another aspect of the present invention, virtual local storage on remote SCSI storage devices is provided to Fiber Channel devices. A Fibre Channel transport medium and a SCSI bus transport medium are interfaced with. A configuration is maintained for SCSI storage devices connected to the SCSI bus transport medium. The configuration maps between Fiber Channel devices and the SCSI storage devices and implements access controls for storage space on the SCSI storage devices. Access is then allowed from Fiber Channel initiator devices to SCSI storage devices using native low level, block protocol in accordance with the configuration.

A technical advantage of the present invention is the ability to centralize local storage for networked workstations without any cost of speed or overhead. Each workstation access its virtual local storage as if it work locally connected. Further, the centralized storage devices can be located in a significantly remote position even in excess of ten kilometers as defined by Fibre Channel standards.

Another technical advantage of the present invention is the ability to centrally control and administer storage space for connected users without limiting the speed with which the users can access local data. In addition, global access to data, backups, virus scanning and redundancy can be more easily accomplished by centrally located storage devices.

A further technical advantage of the present invention is providing support for SCSI storage devices as local storage for Fiber Channel hosts. In addition, the present invention helps to provide extended capabilities for Fiber Channel and for management of storage subsystems.

**BRIEF DESCRIPTION OF THE DRAWINGS**

A more complete understanding of the present invention and the advantages thereof may be acquired by referring to the following description taken in conjunction with the accompanying drawings, in which like reference numbers indicate like features, and wherein:

FIG. 1 is a block diagram of a conventional network that provides storage through a network server;

FIG. 2 is a block diagram of one embodiment of a storage network with a storage router that provides global access and routing;

FIG. 3 is a block diagram of one embodiment of a storage network with a storage router that provides virtual local storage;

FIG. 4 is a block diagram of one embodiment of the storage router of FIG. 3; and

FIG. 5 is a block diagram of one embodiment of data flow within the storage router of FIG. 4.

**DETAILED DESCRIPTION OF THE INVENTION**

FIG. 1 is a block diagram of a conventional network, indicated generally at 10, that provides access to storage



3

through a network server. As shown, network 10 includes a plurality of workstations 12 interconnected with a network server 14 via a network transport medium 16. Each workstation 12 can generally comprise a processor, memory, input/output devices, storage devices and a network adapter as well as other common computer components. Network server 14 uses a SCSI bus 18 as a storage transport medium to interconnect with a plurality of storage devices 20 (tape drives, disk drives, etc.). In the embodiment of FIG. 1, network transport medium 16 is an network connection and storage devices 20 comprise hard disk drives, although there are numerous alternate transport mediums and storage devices.

In network 10, each workstation 12 has access to its local storage device as well as network access to data on storage devices 20. The access to a local storage device is typically through native low level, block protocols. On the other hand, access by a workstation 12 to storage devices 20 requires the participation of network server 14 which implements a file system and transfers data to workstations 12 only through high level file system protocols. Only network server 14 communicates with storage devices 20 via native low level, block protocols. Consequently, the network access by workstations 12 through network server 14 is slow with respect to their access to local storage. In network 10, it can also be a logistical problem to centrally manage and administer local data distributed across an organization, including accomplishing tasks such as backups, virus scanning and redundancy.

FIG. 2 is a block diagram of one embodiment of a storage network, indicated generally at 30, with a storage router that provides global access and routing. This environment is significantly different from that of FIG. 1 in that there is no network server involved. In FIG. 2, a Fiber Channel high speed serial transport 32 interconnects a plurality of workstations 36 and storage devices 38. A SCSI bus storage transport medium interconnects workstations 40 and storage devices 42. A storage router 44 then serves to interconnect these mediums and provide devices on either medium global, transparent access to devices on the other medium. Storage router 44 routes requests from initiator devices on one medium to target devices on the other medium and routes data between the target and the initiator. Storage router 44 can allow initiators and targets to be on either side. In this manner, storage router 44 enhances the functionality of Fiber Channel 32 by providing access, for example, to legacy SCSI storage devices on SCSI bus 34. In the embodiment of FIG. 2, the operation of storage router 44 can be managed by a management station 46 connected to the storage router via a direct serial connection.

In storage network 30, any workstation 36 or workstation 40 can access any storage device 38 or storage device 42 through native low level, block protocols, and vice versa. This functionality is enabled by storage router 44 which routes requests and data as a generic transport between Fiber Channel 32 and SCSI bus 34. Storage router 44 uses tables to map devices from one medium to the other and distributes requests and data across Fiber Channel 32 and SCSI bus 34 without any security access controls. Although this extension of the high speed serial interconnect provided by Fiber Channel 32 is beneficial, it is desirable to provide security controls in addition to extended access to storage devices through a native low level, block protocol.

FIG. 3 is a block diagram of one embodiment of a storage network, indicated generally at 50, with a storage router that provides virtual local storage. Similar to that of FIG. 2, storage network 50 includes a Fiber Channel high speed

4

serial interconnect 52 and a SCSI bus 54 bridged by a storage router 56. Storage router 56 of FIG. 3 provides for a large number of workstations 58 to be interconnected on a common storage transport and to access common storage devices 60, 62 and 64 through native low level, block protocols.

According to the present invention, storage router 56 has enhanced functionality to implement security controls and routing such that each workstation 58 can have access to a specific subset of the overall data stored in storage devices 60, 62 and 64. This specific subset of data has the appearance and characteristics of local storage and is referred to herein as virtual local storage. Storage router 56 allows the configuration and modification of the storage allocated to each attached workstation 58 through the use of mapping tables or other mapping techniques.

As shown in FIG. 3, for example, storage device 60 can be configured to provide global data 65 which can be accessed by all workstations 58. Storage device 62 can be configured to provide partitioned subsets 66, 68, 70 and 72, where each partition is allocated to one of the workstations 58 (workstations A, B, C and D). These subsets 66, 68, 70 and 72 can only be accessed by the associated workstation 58 and appear to the associated workstation 58 as local storage accessed using native low level, block protocols. Similarly, storage device 64 can be allocated as storage for the remaining workstation 58 (workstation E).

Storage router 56 combines access control with routing such that each workstation 58 has controlled access to only the specified partition of storage device 62 which forms virtual local storage for the workstation 58. This access control allows security control for the specified data partitions. Storage router 56 allows this allocation of storage devices 60, 62 and 64 to be managed by a management station 76. Management station 76 can connect directly to storage router 56 via a direct connection or, alternately, can interface with storage router 56 through either Fiber Channel 52 or SCSI bus 54. In the latter case, management station 76 can be a workstation or other computing device with special rights such that storage router 56 allows access to mapping tables and shows storage devices 60, 62 and 64 as they exist physically rather than as they have been allocated.

The environment of FIG. 3 extends the concept of a single workstation having locally connected storage devices to a storage network 50 in which workstations 58 are provided virtual local storage in a manner transparent to workstations 58. Storage router 56 provides centralized control of what each workstation 58 sees as its local drive, as well as what data it sees as global data accessible by other workstations 58. Consequently, the storage space considered by the workstation 58 to be its local storage is actually a partition (i.e., logical storage definition) of a physically remote storage device 60, 62 or 64 connected through storage router 56. This means that similar requests from workstations 58 for access to their local storage devices produce different accesses to the storage space on storage devices 60, 62 and 64. Further, no access from a workstation 58 is allowed to the virtual local storage of another workstation 58.

The collective storage provided by storage devices 60, 62 and 64 can have blocks allocated by programming means within storage router 56. To accomplish this function, storage router 56 can include routing tables and security controls that define storage allocation for each workstation 58. The advantages provided by implementing virtual local storage in centralized storage devices include the ability to do collective backups and other collective administrative func-



5

tions more easily. This is accomplished without limiting the performance of workstations 58 because storage access involves native low level, block protocols and does not involve the overhead of high level protocols and file systems required by network servers.

FIG. 4 is a block diagram of one embodiment of storage router 56 of FIG. 3. Storage router 56 can comprise a Fiber Channel controller 80 that interfaces with Fiber Channel 52 and a SCSI controller 82 that interfaces with SCSI bus 54. A buffer 84 provides memory work space and is connected to both Fiber Channel controller 80 and to SCSI controller 82. A supervisor unit 86 is connected to Fiber Channel controller 80, SCSI controller 82 and buffer 84. Supervisor unit 86 comprises a microprocessor for controlling operation of storage router 56 and to handle mapping and security access for requests between Fiber Channel 52 and SCSI bus 54.

FIG. 5 is a block diagram of one embodiment of data flow within storage router 56 of FIG. 4. As shown, data from Fiber Channel 52 is processed by a Fibre Channel (FC) protocol unit 88 and placed in a FIFO queue 90. A direct memory access (DMA) interface 92 then takes data out of FIFO queue 90 and places it in buffer 84.

Supervisor unit 86 processes the data in buffer 84 as represented by supervisor processing 93. This processing involves mapping between Fiber Channel 52 and SCSI bus 54 and applying access controls and routing functions. A DMA interface 94 then pulls data from buffer 84 and places it into a buffer 96. A SCSI protocol unit 98 pulls data from buffer 96 and communicates the data on SCSI bus 54. Data flow in the reverse direction, from SCSI bus 54 to Fiber Channel 52, is accomplished in a reverse manner.

The storage router of the present invention is a bridge device that connects a Fiber Channel link directly to a SCSI bus and enables the exchange of SCSI command set information between application clients on SCSI bus devices and the Fiber Channel links. Further, the storage router applies access controls such that virtual local storage can be established in remote SCSI storage devices for workstations on the Fiber Channel link. In one embodiment, the storage router provides a connection for Fiber Channel links running the SCSI Fiber Channel Protocol (FCP) to legacy SCSI devices attached to a SCSI bus. The Fiber Channel topology is typically an Arbitrated Loop (FC\_AL).

In part, the storage router enables a migration path to Fiber Channel based, serial SCSI networks by providing connectivity for legacy SCSI bus devices. The storage router can be attached to a Fiber Channel Arbitrated Loop and a SCSI bus to support a number of SCSI devices. Using configuration settings, the storage router can make the SCSI bus devices available on the Fiber Channel network as FCP logical units. Once the configuration is defined, operation of the storage router is transparent to application clients. In this manner, the storage router can form an integral part of the migration to new Fibre Channel based networks while providing a means to continue using legacy SCSI devices.

In one implementation (not shown), the storage router can be a rack mount or free standing device with an internal power supply. The storage router can have a Fibre Channel and SCSI port, and a standard, detachable power cord can be used, the FC connector can be a copper DB9 connector, and the SCSI connector can be a 68-pin type. Additional modular jacks can be provided for a serial port and a 802.3 10BaseT port, i.e. twisted pair Ethernet, for management access. The SCSI port of the storage router can support SCSI direct and sequential access target devices and can support SCSI

6

initiators, as well. The Fiber Channel port can interface to SCSI-3 FCP enabled devices and initiators.

To accomplish its functionality, one implementation of the storage router uses: a Fiber Channel interface based on the HEWLETT-PACKARD TACHYON HPFC-5000 controller and a GLM media interface; an Intel 80960RP processor, incorporating independent data and program memory spaces, and associated logic required to implement a stand alone processing system; and a serial port for debug and system configuration. Further, this implementation includes a SCSI interface supporting Fast-20 based on the SYMBIOS 53C8xx series SCSI controllers, and an operating system based upon the WIND RIVERS SYSTEMS VXWORKS or IXWORKS kernel, as determined by design. In addition, the storage router includes software as required to control basic functions of the various elements, and to provide appropriate translations between the FC and SCSI protocols.

The storage router has various modes of operation that are possible between FC and SCSI target and initiator combinations. These modes are: FC Initiator to SCSI Target; SCSI Initiator to FC Target; SCSI Initiator to SCSI Target; and FC Initiator to FC Target. The first two modes can be supported concurrently in a single storage router device are discussed briefly below. The third mode can involve two storage router devices back to back and can serve primarily as a device to extend the physical distance beyond that possible via a direct SCSI connection. The last mode can be used to carry FC protocols encapsulated on other transmission technologies (e.g. ATM, SONET), or to act as a bridge between two FC loops (e.g. as a two port fabric).

The FC Initiator to SCSI Target mode provides for the basic configuration of a server using Fiber Channel to communicate with SCSI targets. This mode requires that a host system have an FC attached device and associated device drivers and software to generate SCSI-3 FCP requests. This system acts as an initiator using the storage router to communicate with SCSI target devices. The SCSI devices supported can include SCSI-2 compliant direct or sequential access (disk or tape) devices. The storage router serves to translate command and status information and transfer data between SCSI-3 FCP and SCSI-2, allowing the use of standard SCSI-2 devices in a Fibre Channel environment.

The SCSI Initiator to FC Target mode provides for the configuration of a server using SCSI-2 to communicate with Fiber Channel targets. This mode requires that a host system has a SCSI-2 interface and driver software to control SCSI-2 target devices. The storage router will connect to the SCSI-2 bus and respond as a target to multiple target IDs. Configuration information is required to identify the target IDs to which the bridge will respond on the SCSI-2 bus. The storage router then translates the SCSI-2 requests to SCSI-3 FCP requests, allowing the use of FC devices with a SCSI host system. This will also allow features such as a tape device acting as an initiator on the SCSI bus to provide full support for this type of SCSI device.

In general, user configuration of the storage router will be needed to support various functional modes of operation. Configuration can be modified, for example, through a serial port or through an Ethernet port via SNMP (simple network management protocol) or a Telnet session. Specifically, SNMP manageability can be provided via an 802.3 Ethernet interface. This can provide for configuration changes as well as providing statistics and error information. Configuration can also be performed via TELNET or RS-232 interfaces



US 6,425,035 B2

7

with menu driven command interfaces. Configuration information can be stored in a segment of flash memory and can be retained across resets and power off cycles. Password protection can also be provided.

In the first two modes of operation, addressing information is needed to map from FC addressing to SCSI addressing and vice versa. This can be 'hard' configuration data, due to the need for address information to be maintained across initialization and partial reconfigurations of the Fiber Channel address space. In an arbitrated loop configuration, user configured addresses will be needed for AL\_PAs in order to insure that known addresses are provided between loop reconfigurations.

With respect to addressing, FCP and SCSI 2 systems employ different methods of addressing target devices. Additionally, the inclusion of a storage router means that a method of translating device IDs needs to be implemented. In addition, the storage router can respond to commands without passing the commands through to the opposite interface. This can be implemented to allow all generic FCP and SCSI commands to pass through the storage router to address attached devices, but allow for configuration and diagnostics to be performed directly on the storage router through the FC and SCSI interfaces.

Management commands are those intended to be processed by the storage router controller directly. This may include diagnostic, mode, and log commands as well as other vendor-specific commands. These commands can be received and processed by both the FCP and SCSI interfaces, but are not typically bridged to the opposite interface. These commands may also have side effects on the operation of the storage router, and cause other storage router operations to change or terminate.

A primary method of addressing management commands through the FCP and SCSI interfaces can be through peripheral device type addressing. For example, the storage router can respond to all operations addressed to logical unit (LUN) zero as a controller device. Commands that the storage router will support can include INQUIRY as well as vendor-specific management commands. These are to be generally consistent with SCC standard commands.

The SCSI bus is capable of establishing bus connections between targets. These targets may internally address logical units. Thus, the prioritized addressing scheme used by SCSI subsystems can be represented as follows: BUS:TARGET:LOGICAL UNIT. The BUS identification is intrinsic in the configuration, as a SCSI initiator is attached to only one-bus. Target addressing is handled by bus arbitration from information provided to the arbitrating device. Target addresses are assigned to SCSI devices directly, though some means of configuration, such as a hardware jumper, switch setting, or device specific software configuration. As such, the SCSI protocol provides only logical unit addressing within the Identify message. Bus and target information is implied by the established connection.

Fiber Channel devices within a fabric are addressed by a unique port identifier. This identifier is assigned to a port during certain well-defined states of the FC protocol. Individual ports are allowed to arbitrate for a known, user defined address. If such an address is not provided, or if arbitration for a particular user address fails, the port is assigned a unique address by the FC protocol. This address is generally not guaranteed to be unique between instances. Various scenarios exist where the AL-PA of a device will change, either after power cycle or loop reconfiguration.

The FC protocol also provides a logical unit address field within command structures to provide addressing to devices

8

internal to a port. The FCP\_CMD payload specifies an eight byte LUN field. Subsequent identification of the exchange between devices is provided by the FQXID (Fully Qualified Exchange ID).

5 FC ports can be required to have specific addresses assigned. Although basic functionality is not dependent on this, changes in the loop configuration could result in disk targets changing identifiers with the potential risk of data corruption or loss. This configuration can be straightforward, and can consist of providing the device a loop-unique ID (AL\_PA) in the range of "01h" to "EFh." Storage routers could be shipped with a default value with the assumption that most configurations will be using single storage routers and no other devices requesting the present ID. This would provide a minimum amount of initial configuration to the system administrator. Alternately, storage routers could be defaulted to assume any address so that configurations requiring multiple storage routers on a loop would not require that the administrator assign a unique ID to the additional storage routers.

Address translation is needed where commands are issued in the cases FC Initiator to SCSI Target and SCSI Initiator to FC Target. Target responses are qualified by the FQXID and will retain the translation acquired at the beginning of the exchange. This prevents configuration changes occurring during the course of execution of a command from causing data or state information to be inadvertently misdirected. Configuration can be required in cases of SCSI Initiator to FC Target, as discovery may not effectively allow for FCP targets to consistently be found. This is due to an FC arbitrated loop supporting addressing of a larger number of devices than a SCSI bus and the possibility of FC devices changing their AL-PA due to device insertion or other loop initialization.

35 In the direct method, the translation to BUS:TARGET:LUN of the SCSI address information will be direct. That is, the values represented in the FCP LUN field will directly map to the values in effect on the SCSI bus. This provides a clean translation and does not require SCSI bus discovery. It also allows devices to be dynamically added to the SCSI bus without modifying the address map. It may not allow for complete discovery by FCP initiator devices, as gaps between device addresses may halt the discovery process. Legacy SCSI device drivers typically halt discovery on a target device at the first unoccupied LUN, and proceed to the next target. This would lead to some devices not being discovered. However, this allows for hot plugged devices and other changes to the loop addressing.

50 In the ordered method, ordered translation requires that the storage router perform discovery on reset, and collapses the addresses on the SCSI bus to sequential FCP LUN values. Thus, the FCP LUN values 0-N can represent N+1 SCSI devices, regardless of SCSI address values, in the order in which they are isolated during the SCSI discovery process. This would allow the FCP initiator discovery process to identify all mapped SCSI devices without further configuration. This has the limitation that hot-plugged devices will not be identified until the next reset cycle. In this case, the address may also be altered as well.

65 In addition to addressing, according to the present invention, the storage router provides configuration and access controls that cause certain requests from FC Initiators to be directed to assigned virtual local storage partitioned on SCSI storage devices. For example, the same request for LUN 0 (local storage) by two different FC Initiators can be directed to two separate subsets of storage. The storage



router can use tables to map, for each initiator, what storage access is available and what partition is being addressed by a particular request. In this manner, the storage space provided by SCSI storage devices can be allocated to FC initiators to provide virtual local storage as well as to create any other desired configuration for secured access.

Although the present invention has been described in detail, it should be understood that various changes, substitutions, and alterations can be made hereto without departing from the spirit and scope of the invention as defined by the appended claims.

What is claimed is:

1. A storage router for providing virtual local storage on remote storage devices to devices, comprising:

- a buffer providing memory work space for the storage router;
- a first controller operable to connect to and interface with a first transport medium;
- a second controller operable to connect to and interface with a second transport medium; and
- a supervisor unit coupled to the first controller, the second controller and the buffer, the supervisor unit operable to map between devices connected to the first transport medium and the storage devices, to implement access controls for storage space on the storage devices and to process data in the buffer to interface between the first controller and the second controller to allow access from devices connected to the first transport medium to the storage devices using native low level, block protocols.

2. The storage router of claim 1, wherein the supervisor unit maintains an allocation of subsets of storage space to associated devices connected to the first transport medium, wherein each subset is only accessible by the associated device connected to the first transport medium.

3. The storage router of claim 2, wherein the devices connected to the first transport medium comprise workstations.

4. The storage router of claim 2, wherein the storage devices comprise hard disk drives.

5. The storage router of claim 1, wherein the first controller comprises:

- a first protocol unit operable to connect to the first transport medium;
- a first-in-first-out queue coupled to the first protocol unit; and
- a direct memory access (DMA) interface coupled to the first-in-first-out queue and to the buffer.

6. The storage router of claim 1, wherein the second controller comprises:

- a second protocol unit operable to connect to the second transport medium;
- an internal buffer coupled to the second protocol unit; and
- a direct memory access (DMA) interface coupled to the internal buffer and to the buffer of the storage router.

7. A storage network, comprising:

- a first transport medium;
- a second transport medium;
- a plurality of workstations connected to the first transport medium;
- a plurality of storage devices connected to the second transport medium; and

a storage router interfacing between the first transport medium and the second transport medium, the storage router providing virtual local storage on the storage devices to the workstations and operable:

- to map between the workstations and the storage devices;
- to implement access controls for storage space on the storage devices; and
- to allow access from the workstations to the storage devices using native low level, block protocol in accordance with the mapping and access controls.

8. The storage network of claim 7, wherein the access controls include an allocation of subsets of storage space to associated workstations, wherein each subset is only accessible by the associated workstation.

9. The storage network of claim 7, wherein the storage devices comprise hard disk drives.

10. The storage network of claim 7, wherein the storage router comprises:

- a buffer providing memory work space for the storage router;
- a first controller operable to connect to and interface with the first transport medium, the first controller further operable to pull outgoing data from the buffer and to place incoming data into the buffer;
- a second controller operable to connect to and interface with the second transport medium, the second controller further operable to pull outgoing data from the buffer and to place incoming data into the buffer; and
- a supervisor unit coupled to the first controller, the second controller and the buffer, the supervisor unit operable: to map between devices connected to the first transport medium and the storage devices, to implement the access controls for storage space on the storage devices and to process data in the buffer to interface between the first controller and the second controller to allow access from workstations to storage devices.

11. A method for providing virtual local storage on remote storage devices connected to one transport medium to devices connected to another transport medium, comprising:

- interfacing with a first transport medium;
- interfacing with a second transport medium;
- mapping between devices connected to the first transport medium and the storage devices and that implements access controls for storage space on the storage devices; and
- allowing access from devices connected to the first transport medium to the storage devices using native low level, block protocols.

12. The method of claim 11, wherein mapping between devices connected to the first transport medium and the storage devices includes allocating subsets of storage space to associated devices connected to the first transport medium, wherein each subset is only accessible by the associated device connected to the first transport medium.

13. The method of claim 12, wherein the devices connected to the first transport medium comprise workstations.

14. The method of claim 12, wherein the storage devices comprise hard disk drives.

\* \* \* \* \*

## CERTIFICATE OF CORRECTION

PATENT NO. : 6,425,035 B2  
DATED : July 23, 2002  
INVENTOR(S) : Geoffry B. Hoese et al.

Page 1 of 1

It is certified that error appears in the above-identified patent and that said Letters Patent is hereby corrected as shown below:

Column 10,

Line 47, delete "that implements" and insert -- implementing --

Signed and Sealed this

Twenty-sixth Day of August, 2003

A handwritten signature in black ink, appearing to read "James E. Rogan", with a horizontal line underneath.

JAMES E. ROGAN  
*Director of the United States Patent and Trademark Office*





US006425035C1

(12) **EX PARTE REEXAMINATION CERTIFICATE** (5472nd)

**United States Patent**

(10) **Number:** **US 6,425,035 C1**

**Hoese et al.**

(45) **Certificate Issued:** **\*Aug. 8, 2006**

- (54) **STORAGE ROUTER AND METHOD FOR PROVIDING VIRTUAL LOCAL STORAGE**
- (75) Inventors: **Geoffrey H. Hoese**, Austin, TX (US);  
**Jeffrey T. Russell**, Cibolo, TX (US)
- (73) Assignee: **Crossworlds Software**, Burlingame, CA (US)

- 4,864,532 A 9/1989 Reeve et al.
- 4,947,367 A 8/1990 Chang et al.
- 5,072,378 A 12/1991 Manka
- 5,163,131 A 11/1992 Row et al.
- 5,239,632 A 8/1993 Larner
- 5,239,643 A 8/1993 Blount et al.

(Continued)

**Reexamination Request:**

No. 90/007,125, Jul. 19, 2004  
No. 90/007,317, Nov. 23, 2004

**Reexamination Certificate for:**

Patent No.: **6,425,035**  
Issued: **Jul. 23, 2002**  
Appl. No.: **09/965,335**  
Filed: **Sep. 27, 2001**

**FOREIGN PATENT DOCUMENTS**

|    |                |         |
|----|----------------|---------|
| EP | 0810530 A2     | 12/1997 |
| EP | 0827059 A2     | 3/1998  |
| GB | 2296798 A      | 7/1996  |
| GB | 2297636 A      | 8/1996  |
| GB | 2341715        | 3/2000  |
| JP | 6301607        | 10/1994 |
| JP | 8-230895       | 9/1996  |
| WO | WO 98/36357    | 8/1998  |
| WO | WO 99/34297 A1 | 7/1999  |

**OTHER PUBLICATIONS**

Systems Architectures Using Fibre Channel, Roger Cummings, Twelfth IEEE Symposium on Mass Storage Systems, copyright 1993 IEEE. pp. 251–256.\*

(Continued)

*Primary Examiner*—Dov Popovici

(57) **ABSTRACT**

A storage router (56) and storage network (50) provide virtual local storage on remote SCSI storage devices (60, 62, 64) to Fiber Channel devices. A plurality of Fiber Channel devices, such as workstations (58), are connected to a Fiber Channel transport medium (52), and a plurality of SCSI storage devices (60, 62, 64) are connected to a SCSI bus transport medium (54). The storage router (56) interfaces between the Fibre Channel transport medium (52) and the SCSI bus transport medium (54). The storage router (56) maps between the workstations (58) and the SCSI storage devices (60, 62, 64) and implements access, controls for storage space on the SCSI storage devices (60, 62, 64). The storage router (56) then allows access from the workstations (58) to the SCSI storage devices (60, 62, 64) using native low level, block protocol in accordance with the mapping and the access controls.

(\*) Notice: This patent is subject to a terminal disclaimer.

**Related U.S. Application Data**

- (63) Continuation of application No. 09/354,682, filed on Jul. 15, 1999, now Pat. No. 6,421,753, which is a continuation of application No. 09/001,799, filed on Dec. 31, 1997, now Pat. No. 5,941,972.

- (51) **Int. Cl.** *G06F 13/00* (2006.01)
- (52) **U.S. Cl.** ..... 710/315; 710/2; 710/8; 710/36; 710/105; 710/305; 710/308; 711/112
- (58) **Field of Classification Search** ..... 710/1–5, 710/8–13, 36–38, 105, 100, 101, 305–316; 711/100, 112, 113; 714/42  
See application file for complete search history.

(56) **References Cited**

**U.S. PATENT DOCUMENTS**

- 3,082,406 A 3/1963 Stevens
- 4,092,732 A 5/1978 Ouchi
- 4,695,948 A 9/1987 Blevins et al.
- 4,751,635 A 6/1988 Kret

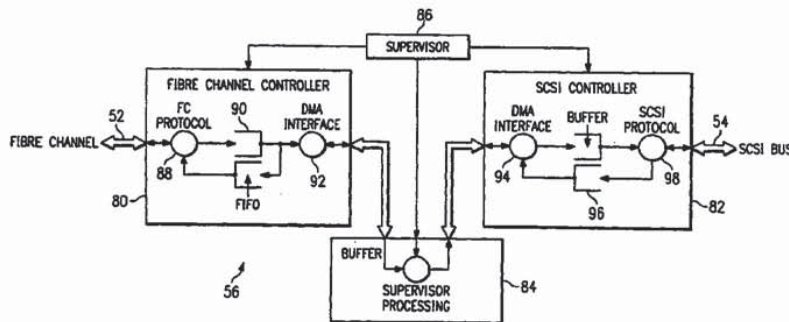

## US 6,425,035 C1

Page 2

## U.S. PATENT DOCUMENTS

5,257,386 A 10/1993 Saito  
 5,345,565 A \* 9/1994 Jibbe et al. .... 710/316  
 5,347,384 A 9/1994 McReynolds et al.  
 5,394,526 A \* 2/1995 Crouse et al. .... 709/219  
 5,414,820 A 5/1995 McFarland et al.  
 5,423,044 A 6/1995 Sutton et al.  
 5,465,382 A 11/1995 Day, III et al.  
 5,530,845 A 6/1996 Hiatt et al.  
 5,535,352 A 7/1996 Bridges et al.  
 5,581,714 A 12/1996 Amini et al.  
 5,596,562 A 1/1997 Chen  
 5,596,736 A 1/1997 Kerns  
 5,598,541 A 1/1997 Malladi  
 5,634,111 A \* 5/1997 Oeda et al. .... 711/153  
 5,680,556 A 10/1997 Begun et al.  
 5,701,491 A 12/1997 Dunn et al.  
 5,712,976 A 1/1998 Falcon et al.  
 5,729,705 A 3/1998 Weber  
 5,743,847 A 4/1998 Nakamura et al.  
 5,751,975 A 5/1998 Gillespie et al.  
 5,774,683 A 6/1998 Gulick  
 5,845,107 A 12/1998 Fisch et al.  
 5,857,080 A 1/1999 Jander et al.  
 5,864,653 A 1/1999 Tavallaei et al.  
 5,867,648 A 2/1999 Foth et al.  
 5,884,027 A 3/1999 Garbus et al.  
 5,913,045 A 6/1999 Gillespie et al.  
 5,923,557 A 7/1999 Eidson  
 5,941,969 A 8/1999 Ram et al.  
 5,953,511 A 9/1999 Sescilia et al.  
 5,959,994 A 9/1999 Boggs et al.  
 5,974,530 A 10/1999 Young  
 5,978,379 A 11/1999 Chan et al.  
 5,991,797 A 11/1999 Futral et al.  
 6,000,020 A 12/1999 Chin et al.  
 6,021,451 A 2/2000 Bell et al.  
 6,070,253 A 5/2000 Tavallaei et al.  
 6,131,119 A 10/2000 Fukui  
 6,134,617 A 10/2000 Weber  
 6,141,737 A 10/2000 Krantz et al.  
 6,145,006 A 11/2000 Vishlitsky et al.  
 6,223,266 B1 4/2001 Sartore  
 6,230,218 B1 5/2001 Casper et al.  
 6,260,120 B1 7/2001 Blumenau et al.  
 6,330,629 B1 12/2001 Kondo et al.  
 6,363,462 B1 3/2002 Bergsten  
 6,421,753 B1 7/2002 Hoese et al.  
 6,425,035 B1 7/2002 Hoese et al.  
 6,425,036 B1 7/2002 Hoese et al.  
 6,484,245 B1 11/2002 Sanada et al.  
 6,529,996 B1 3/2003 Nguyen et al.

## OTHER PUBLICATIONS

Fibre Channel and ATM: The Physical Layers, Jerry Quam, WESCON/94, published Sep. 27–29, 1994. pp. 648–652.\*  
 Petal: Distributed Virtual Disks, Edward K. Lee and Chandramohan A. Thekkath, ACM SIGPLAN Notices, vol. 31, Issue 9, Sep. 1996, pp. 84–92.\*  
 Black Box, SCSI Fiberoptic Extender, Single-Ended, Product Insert, 2 pages, 1996.  
 Burskey, Dave “New Serial I/Os Speed Storage Subsystems” Feb. 6, 1996.  
 CRD–5500, Raid Disk Array Controller Product Insert, pp. 1–5.  
 CRD–5500, SCSI Raid Controller OEM Manual, Rev. 1.3, Feb. 26, 1996, pp. 1–54.

Raidtec FibreArray and Raidtec FlexArray UltraRaid Systems, Windows IT PRO Article, Oct. 1997.  
 DIGITAL Storage Works, HSZ70 Array Controller, HSOF Version 7.0 EK–HSZ70–CG. A01, Digital Equipment Corporation, Maynard, Massachusetts.  
 DIGITAL StorageWorks, Using Your HSZ70 Array Controller in a SCSI Controller Shelf (DS–BA356–M Series), User’s Guide, pp. 1–1 through A–5 with index, Jan. 1998.  
 DIGITAL StorageWorks HSZ270 Array Controller HSOF Version 7.0 EK–HSZ270–RM. A01. CLI Reference Manual.  
 DIGITAL StorageWorks HSG80 Array Controller ACS Version 8.0 (User’s Guide) Jan. 1998.  
 DIGITAL StorageWorks HSZ70 Array Controller HSOF Version 7.0 EK–HSZ70–SV. A01.  
 Emerson, “Ancor Communications: Performance evaluation of switched fibre channel I/O system using—FCP for SCSI” Feb. 1995, IEEE, pp. 479–484.  
 IBM Technical Publication: Magstar and IBM 3590 High Performance Tape Subsystem Technical Guide, Nov. 1996, pp. 1–269.  
 Guide to Sharing and Partitioning IBM Tape Library Dataservers, Nov. 1996, IBM, International Technical Support Organization, San Jose Center.  
 Misc. Reference Manual Pages, SunOS 5.09.  
 Block-Based Distributed File Systems, Anthony J. McGregor, Jul. 1997.  
 InfoServer 150VXT Photograph.  
 Pictures of internal components of the InfoServer 150, taken from <http://bindarydinosaurs.couk/Museum/Digital/Infoserver/infoserver.php> in Nov. 2004.  
 Simplest Migration to Fibre Channel Technology.  
 Compaq StorageWorks HSG80 Array Controller ACS Version 8.3 (Maintenance and Service Guide) Nov. 1998.  
 Compaq StorageWorks HSG80 Array Controller ACS Version 8.3 (Configuration and CLI Reference Guide) Nov. 1998.  
 Office Action dated Jan. 21, 2003 for 10/174,720.  
 Office Action dated Feb. 27, 2001 for 09/354,682.  
 Office Action dated Aug. 11, 2000 for 09/354,682.  
 Office Action dated Dec. 16, 1999 for 09/354,682.  
 Office Action dated Nov. 6, 2002, for 10/023,786.  
 Office Action dated Jan. 21, 2003 for 10/081,110.  
 Office Action dated Jan. 27, 2005 in 10/658,163.  
 Office Action in Ex Parte Reexamination 90/007,127, mailed Feb. 7, 2005.  
 Office Action in Ex Parte Reexamination 90/007,126, mailed Feb. 7, 2005.  
 Office Action in Ex Parte Reexamination 90/007,124, mailed Feb. 7, 2005.  
 Office Action in Ex Parte Reexamination 90/007,123, mailed Feb. 7, 2005.  
 European Office Action issued Apr. 1, 2004 in Application No. 98966104.6–2413.  
 Defendant’s First Supplemental Trial Exhibit List, *Crossroads Systems, Inc., v. Chaparral Network Storage, Inc.*, C.A. No. A–00CA–217–SS (W.D. Tex. 2001), (CD–Rom).  
 Defendant’s Third Supplemental Trial Exhibit List, *Crossroads Systems, Inc. v. Pathlight Technology, Inc.*, C.A. No. A–00CA–248–SS (W.D. Tex. 2001) (CD–Rom).  
 Defendant’s Trial Exhibits, *Crossroads Systems, Inc. v. Pathlight Technology, Inc.*, C.A. No. A–00CA–248–SS (W.D. Tex. 2001). (CD–Rom).



## US 6,425,035 C1

Page 3

Defendants' Trial Exhibits, *Crossroads Systems, Inc., v. Chaparral Network Storage, Inc.*, C.A. No. A-00CA-217-SS (W.D. Tex. 2001) (CD-Rom).

Defendant Chaparral Network Storage, Inc.'s First Supplemental Trial Exhibit List (D1 through D271) (CD-ROM Chaparral Exhibits ExList\_Def), Sep. 2, 2001.

Defendant Pathlight Technology Inc.'s Third Supplemental Trial Exhibit List (CD-ROM Pathlight Exhibits ExList\_Def).

Plaintiff's Fourth Amended Trial Exhibit List, *Crossroads Systems, Inc. v. Chaparral Network Storage, Inc.*, C.A. No. A-00CA-217-SS (W.D. Tex. 2001) (CD-Rom), Sep. 11, 2001.

Plaintiff's Revised Trial Exhibit List, *Crossroads Systems, Inc. v. Pathlight Technology, Inc.*, C.A. No. A-00CA-248-SS (W.D. Tex. 2001) (CD-Rom).

Plaintiff's Trial Exhibits, *Crossroads Systems, Inc. v. Chaparral Networks Storage, Inc.*, C.A. No. A-00CA-217-SS (W.D. Tex. 2001) (CD-Rom).

Plaintiff's Fourth Amended Trial Exhibit List (CD-ROM Chaparral Exhibits ExList\_Plaintiff), Sep. 11, 2001.

Plaintiff's Revised Trial Exhibit List (CD-ROM Pathlight Exhibits ExList\_Plaintiff).

Trail Transcripts, *Crossroads Systems, Inc. v. Chaparral Network Storage, Inc.*, C.A. No. A-00CA-217-SS (W.D. Tex. 2001) (CD-Rom).

Trail Transcripts, *Crossroads Systems, Inc. v. Pathlight Technology, Inc.*, C.A. No. A-00CA-248-SS (W.D. Tex. 2001) (CD-Rom).

Trial Exhibits and Transcripts, *Crossroads v. Chaparral*, Civil Action No. A-00CA-21755, W.D. Tex. 2000 (CD-Rom and hard copy printouts).

Snively, "Sun Microsystem Computer Corporation: Implementing a fibre optic channel SCSI transport" 1994 IEEE, Feb. 28, 1994, pp. 78-82.

Datasheet for CrossPoint 4100 Fibre Channel to SCSI Router (Dedek Ex 41 (ANCT 117-120)) (CD-ROM Chaparral Exhibits D012).

Symbios Logic—Software Interface Specification Series 3 SCSI RAID Controller Software Release 02.xx (Engelbrecht Ex 2 (LSI 1421-1658)) (CD-ROM Chaparral Exhibits D013), Dec. 3, 1997.

Press Release—Symbios Logic to Demonstrate Strong Support for Fibre Channel at Fall Comdex (Engelbrecht 12 (LSI 2785-86)) (CD-ROM Chaparral Exhibits D016), Nov. 13, 1996.

OEM Datasheet on the 3701 Controller (Engelbrecht 13 (LSI 01837-38)) (CD-ROM Chaparral Exhibits D017), Jun. 17, 1905.

Nondisclosure Agreement Between Adaptec and Crossroads Dated Oct. 17, 1996 (Quisenberry Ex 25 (CRDS 8196)) (CD-ROM Chaparral Exhibits D020).

Organizational Presentation on the External Storage Group (Lavan Ex 1 (CNS 182242-255)) (CD-ROM Chaparral Exhibits D021), Apr. 11, 1996.

Bridge. C, Bridge Between SCSI-2 and SCSI-3 FCP (Fibre Channel Protocol) (CD-ROM Chaparral Exhibits P214).

Bridge Phase II Architecture Presentation (Lavan Ex 2 (CNS 182287-295)) (CD-ROM Chaparral Exhibits D022), Apr. 12, 1996.

Attendees/Action Items from Apr. 12, 1996 Meeting at BTC (Lavan Ex 3 (CNS 182241)) (CD-ROM Chaparral Exhibits D023), Apr. 12, 1996.

Brooklyn Hardware Engineering Requirements Documents, Revision 1.4 (Lavan Ex 4 (CNS 178188-211)) (CD-ROM Chaparral Exhibits D024) by Pecone, May 26, 1996.

Brooklyn Single-Ended SCSI RAID Bridge Controller Hardware OEM Manual, Revision 2.1 (Lavan Ex 5 (CNS 177169-191)) (CD-ROM Chaparral Exhibits D025), Mar. 21, 1996.

Coronado Hardware Engineering Requirements Document, Revision 0.0 (Lavan Ex 7 (CNS 176917-932)). (CD-ROM Chaparral Exhibits D027) by O'Dell, Sep. 30, 1996.

ESS/FPG Organization (Lavan Ex 8 (CNS 178639-652)) (CD-ROM Chaparral Exhibits D028), Dec. 6, 1996.

Adaptec MCS ESS Presents: Intelligent External I/O Raid Controllers "Bridge" Strategy (Lavan Ex 9 (CNS 178606-638)). (CD-ROM Chaparral Exhibits D029), Feb. 6, 1996.

AEC-7313 Fibre Channel Daughter Board (for Brooklyn) Engineering Specification, Revision 1.0 (Lavan Ex 10 (CNS 176830-850)) (CD-ROM Chaparral Exhibits D030), Feb. 27, 1997.

Bill of Material (Lavan Ex 14 (CNS 177211-214)) (CD-ROM Chaparral Exhibits D034), Jul. 24, 1997.

AEC-. 4412B, AEC-7412/B2 External RAID Controller Hardware OEM Manual, Revision 2.0 (Lavan Ex 15 (CNS 177082-123)) (CD-ROM Chaparral Exhibits D035), Jun. 27, 1997.

Coronado II, AEC-7312A Fibre Channel Daughter (for Brooklyn) Hardware Specification, Revision 1.2 (Lavan Ex 16 (CNS 177192-210)) (CD-ROM Chaparral Exhibits D037) by Tom Yang, Jul. 18, 1997.

AEC-4412B, AEC7412/3B External RAID Controller Hardware OEM Manual, Revision 3.0. (Lavan Ex 17 (CNS 177124-165)) (CD-ROM Chaparral Exhibits D036), Aug. 25, 1997.

Memo Dated Aug. 15, 1997 to AEC-7312A Evaluation Unit Customers re: B001 Release Notes (Lavan Ex 18 (CNS 182878-879)) (CD-ROM Chaparral Exhibits D038), Aug. 15, 1997.

Brooklyn Main Board (AES-0302) MES Schedule (Lavan Ex 19 (CNS 177759-763)) (CD-ROM Chaparral Exhibits D039), Feb. 11, 1997.

News Release—Adaptec Adds Fibre Channel Option to its External RAID Controller Family (Lavan Ex 20 (CNS 182932-934)) (CD-ROM Chaparral Exhibits D040), May 6, 1997.

AEC-4412B/7412B User's Guide, Rev. A (Lavan Ex 21) (CD-ROM Chaparral Exhibits D041), Jun. 19, 1905.

Data Book—AIC-7895 PCI Bus Master Single Chip SCSI Host Adapter (Davies Ex 1 (CNS 182944-64)) (CD-ROM Chaparral Exhibits D046), May 21, 1996.

Data Book—AIC-1160 Fibre Channel Host Adapter ASIC (Davies Ex 2 (CNS 181800-825)) (CD-ROM Chaparral Exhibits D047), Jun. 18, 1905.

Viking RAID Software (Davies Ex 3 (CNS 180969-181026)) (CD-ROM Chaparral Exhibits D048), Jun. 18, 1905.

Header File with Structure Definitions (Davies Ex 4 (CNS 180009-018)) (CD-ROM Chaparral Exhibits D049), Aug. 8, 1996.

C++ SourceCode for the SCSI Command Handler (Davies Ex 5 (CNS 179136-168)) (CD-ROM Chaparral Exhibits D050), Aug. 8, 1996.

Header File Data Structure (Davies Ex 6 (CNS 179997-180008)) (CD-ROM Chaparral Exhibits D051), Jan. 2, 1997.

SCSI Command Handler (Davies Ex 7 (CNS 179676-719)) (CD-ROM Chaparral Exhibits D052), Jan. 2, 1997.



## US 6,425,035 C1

Page 4

Coronado: Fibre Channel to SCSI Intelligent RAID Controller Product Brief (Kalwitz Ex I (CNS 182804-805)) (CD-ROM Chaparral Exhibits D053).

Bill of Material (Kalwitz Ex 2 (CNS 181632-633)) (CD-ROM Chaparral Exhibits D054), Mar. 17, 1997.

Emails Dated Jan. 13-Mar. 31, 1997 from P. Collins to Mo re: Status Reports (Kalwitz Ex 3 (CNS 182501-511)) (CD-ROM Chaparral Exhibits D055).

Hardware Schematics for the Fibre Channel Daughtercard Coronado (Kalwitz Ex 4 (CNS 181639-648)) (CD-ROM Chaparral Exhibits D056).

Adaptec Schematics re AAC-340 (Kalwitz Ex 14 CNS 177215-251)) (CD-ROM Chaparral Exhibits D057).

Bridge Product Line Review (Manzanares Ex 3 (CNS 177307-336)) (CD-ROM Chaparral Exhibits D058).

AEC Bridge Series Products-Adaptec External Controller RAID Products Pre-Release Draft, v.6 (Manzanares Ex 4 (CNS 174632-653)). (CD-ROM Chaparral Exhibits D059), Oct. 28, 1997.

Hewlett-Packard Roseville Site Property Pass for Brian Smith (Dunning Ex 14 (HP 489)) (CD-ROM Chaparral Exhibits D078), Nov. 7, 1996.

Distribution Agreement Between Hewlett-Packard and Crossroads (Dunning Ex 15 (HP 326-33)) (CD-ROM Chaparral Exhibits D079).

HPFC-5000 Tachyon User's Manuel, First Edition (PTI 17249-839) (CD-ROM Chaparral Exhibits D084), May 1, 1996.

X3T10 994D-(Draft) Information Technology: SCSI-3 Architecture Model, Rev. 1.8 (PTI 165977) (CD-ROM Chaparral Exhibits D087).

X3T10 Project 1047D: Information Technology-SCSI-3 Controller Commands (SCC), Rev. 6c (PTI 166400-546) (CD-ROM Chaparral Exhibits D088), Sep. 3, 1996.

X3T10 995D-(Draft) SCSI-3 Primary Commands, Rev. 11 (Wanamaker Ex 5 (PTI 166050-229)) (CD-ROM Chaparral Exhibits D089), Nov. 13, 1996.

VBAR Volume Backup and Restore (CRDS 12200-202) (CD-ROM Chaparral Exhibits D099).

Preliminary Product Literature for Infinity Commstor's Fibre Channel to SCSI Protocol Bridge (Smith Ex 11; Quisenberry Ex 31 (SPL0 428-30)) (CD-ROM Chaparral Exhibits D143), Aug. 19, 1996.

Letter dated Jul. 12, 1996 from J. Boykin to B. Smith re: Purchase Order for Evaluation Units from Crossroads (Smith Ex 24) CRDS 8556-57) (CD-ROM Chaparral Exhibits D144), Jul. 12, 1996.

CrossPoint 4100 Fibre Channel to SCSI Router Preliminary Datasheet (Hulsey Ex 9 (CRDS 16129-130)) (CD-ROM Chaparral Exhibits D145), Nov. 1, 1996.

CrossPoint 4400 Fibre Channel to SCSI Router Preliminary Datasheet (Bardach Ex. 9, Quisenberry Ex 33 (CRDS 25606-607)) (CD-ROM Chaparral Exhibits D153), Nov. 1, 1996.

Fax Dated Jul. 22, 1996 from L. Petti to B. Smith re: Purchase Order from Data General for FC2S Fibre to Channel SCSI Protocol Bridge Model 11 (Smith Ex 25; Quisenberry Ex 23; Bardach Ex 11 (CRDS 8552-55; 8558)) (CD-ROM Chaparral Exhibits D155).

Email Dated Dec. 20, 1996 from J. Boykin to B. Smith re: Purchase Order for Betas in Feb. and Mar. (Hoese Ex 16, Quisenberry Ex 25; Bardach Ex 12 (CRDS 13644-650)) (CD-ROM Chaparral Exhibits D156).

Infinity Commstor Fibre Channel Demo for Fall Comdex, 1996 (Hoese Ex 15, Bardach Ex 13 (CRDS 27415)) (CD-ROM Chaparral Exhibits D157).

Fax Dated Dec. 19, 1996 from B. Bardach to T. Rarich re: Purchase Order Information (Bardach Ex. 14; Smith Ex 16 (CRDS 4460)) (CD-ROM Chaparral Exhibits D158).

Miscellaneous Documents Regarding Comdex (Quisenberry Ex 2 (CRDS 27415-465)) (CD-ROM Chaparral Exhibits D165).

CrossPoint 4100 Fibre Channel to SCSI Router Preliminary Datasheet (Quisenberry) Ex 3 (CRDS 4933-34) (CD-ROM Chaparral Exhibits D166) (CD-ROM Chaparral Exhibits D166).

CrossPoint 4400 Fibre to Channel to SCSI Router Preliminary Datasheet; Crossroads Company and Product Overview (Quisenberry Ex 4 (CRDS 25606; 16136)) (CD-ROM Chaparral Exhibits D167).

Crossroads Purchase Order Log (Quisenberry Ex 9 (CRDS 14061-062)) (CD-ROM Chaparral Exhibits D172).

RAID Manager 5 with RDAC 5 for UNIX V.4 User's Guide (LSI-01854) (CD-ROM Chaparral Exhibits P062), Sep. 1, 1996.

Letter dated May 12, 1997 from Alan G. Leal to Barbara Bardach enclosing the original OEM License and Purchase Agreement between Hewlett-Packard Company and Crossroads Systems, Inc. (CRDS 02057) (CD-ROM Chaparral Exhibits P130).

CR4x00 Product Specification (CRDS 43929) (CD-ROM Chaparral Exhibits P267), Jun. 1, 1998.

Symbios Logic-Hardware Functional Specification for the Symbios Logic Series 3 Fibre Channel Disk Array Controller Model 3701 (Engelbrecht Ex 3 (LSI-1659-1733)) (CD-ROM Pathlight Exhibits D074).

Report of the Working Group on Storage I/O for Large Scale Computing; Department of Computer Science Duke University: CS-1996-21 (PTI 173330-347). (CD-ROM Pathlight Exhibits D098).

Brian Allison's 1999 Third Quarter Sales Plan (PDX 38 )CNS 022120-132)) (CD-ROM Pathlight Exhibits D201), Jun. 5, 2001.

Brooklyn SCSI-SCSI Intelligent External RAID Bridge Definition Phase External Documentation (CD-ROM Pathlight Exhibits D129).

"InfoServer 100 System Operations Guide", First Edition, Digital Equipment Corporation, 1990.

S.P. Joshi, "Ethernet controller chip interfaces with variety of 16-bit processors," Electronic Design, Hayden Publishing Co., Inc., Rochelle Park, NJ, Oct. 14, 1982, pp 193-200.

"DP5380 Asynchronous SCSI Interface", National Semiconductor Corporation, Arlington, TX, May 1989, pp. 1-32.

Johnson, D.B., et al., "The Peregrine High Performance RPC System", Software-Practice & Experience, 23(2):201-221, Feb. 1993.

"InfoServer 150-Installation and Owner's Guide", EK-INFV-OM-001, Digital Equipment Corporation, Maynard, Massachusetts 1991, Chapters 1 and 2.

Pictures of internal components of the InfoServer 150, taken from <http://www.binarydinosaurs.co.uk/Museum/Digital/infoserver/infoserver.php> in Nov. 2004.

\* cited by examiner

US 6,425,035 C1

**1**  
**EX PARTE**  
**REEXAMINATION CERTIFICATE**  
**ISSUED UNDER 35 U.S.C. 307**

NO AMENDMENTS HAVE BEEN MADE TO  
THE PATENT

**2**  
AS A RESULT OF REEXAMINATION, IT HAS BEEN  
DETERMINED THAT:

5 The patentability of claims 1-14 is confirmed.

\* \* \* \* \*

# **EXHIBIT B**





US007934041B2

(12) **United States Patent**  
**Hoese et al.**

(10) **Patent No.:** **US 7,934,041 B2**

(45) **Date of Patent:** **Apr. 26, 2011**

(54) **STORAGE ROUTER AND METHOD FOR PROVIDING VIRTUAL LOCAL STORAGE**

(75) Inventors: **Geoffrey B. Hoese**, Austin, TX (US);  
**Jeffrey T. Russell**, Cibolo, TX (US)

(73) Assignee: **Crossroads Systems, Inc.**, Austin, TX (US)

(\* ) Notice: Subject to any disclaimer, the term of this patent is extended or adjusted under 35 U.S.C. 154(b) by 0 days.

(21) Appl. No.: **12/690,592**

(22) Filed: **Jan. 20, 2010**

(65) **Prior Publication Data**

US 2010/0121993 A1 May 13, 2010

**Related U.S. Application Data**

(63) Continuation of application No. 12/552,885, filed on Sep. 2, 2009, which is a continuation of application No. 11/851,724, filed on Sep. 7, 2007, now Pat. No. 7,689,754, which is a continuation of application No. 11/442,878, filed on May 30, 2006, now abandoned, which is a continuation of application No. 11/353,826, filed on Feb. 14, 2006, now Pat. No. 7,340,549, which is a continuation of application No. 10/658,163, filed on Sep. 9, 2003, now Pat. No. 7,051,147, which is a continuation of application No. 10/081,110, filed on Feb. 22, 2002, now Pat. No. 6,789,152, which is a continuation of application No. 09/354,682, filed on Jul. 15, 1999, now Pat. No. 6,421,753, which is a continuation of application No. 09/001,799, filed on Dec. 31, 1997, now Pat. No. 5,941,972.

(51) **Int. Cl.**  
**G06F 13/00** (2006.01)  
**G06F 3/00** (2006.01)

(52) **U.S. Cl.** ..... **710/305; 710/11; 709/258**

(58) **Field of Classification Search** ..... 710/1-5, 710/8-13, 36-38, 126-131, 250, 305; 709/258; 714/42; 711/110-113  
See application file for complete search history.

(56) **References Cited**

U.S. PATENT DOCUMENTS

3,082,406 A 3/1963 Stevens  
4,092,732 A 5/1978 Ouchi  
(Continued)

FOREIGN PATENT DOCUMENTS

AU 647414 3/1994  
(Continued)

OTHER PUBLICATIONS

Black Box, SCSI Fiberoptic Extender, Single-Ended, Product Insert, 2 pages, 1996, Jun. 18, 1905.

(Continued)

*Primary Examiner* — Christopher B Shin

(74) *Attorney, Agent, or Firm* — Sprinkle IP Law Group

(57) **ABSTRACT**

A storage router and storage network provide virtual local storage on remote storage devices. A plurality of devices are connected to a first transport medium. In one embodiment, a storage router maintains a map to allocate storage space on the remote storage devices to devices connected to the first transport medium by associating representations of the devices connected to the first transport medium with representations of storage space on the remote storage devices. The storage router controls access from the devices connected to the first transport medium to the storage space on the remote storage devices in accordance with the map and allows access from devices connected to the first transport medium to the remote storage devices using native low level block protocol.

**53 Claims, 2 Drawing Sheets**

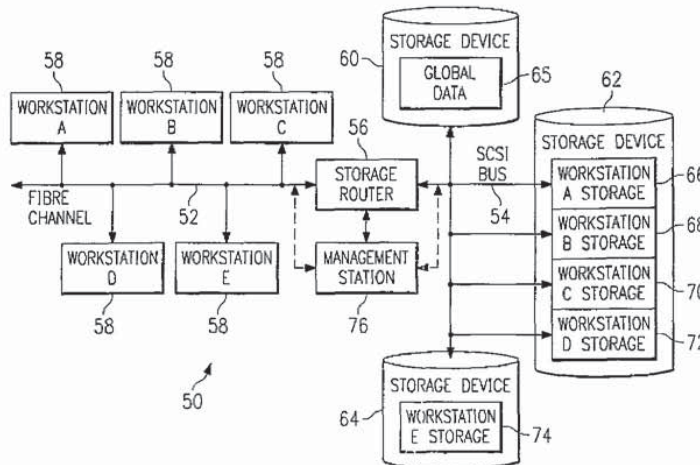

## US 7,934,041 B2

Page 2

| U.S. PATENT DOCUMENTS |         |                     |
|-----------------------|---------|---------------------|
| 4,170,415 A           | 10/1979 | Lemeshefsky et al.  |
| 4,415,970 A           | 11/1983 | Swenson et al.      |
| 4,455,605 A           | 6/1984  | Cormier et al.      |
| 4,504,927 A           | 3/1985  | Callan              |
| 4,533,996 A           | 8/1985  | Gartung et al.      |
| 4,573,152 A           | 2/1986  | Greene et al.       |
| 4,603,380 A           | 7/1986  | Easton et al.       |
| 4,620,295 A           | 10/1986 | Aiden, Jr.          |
| 4,644,462 A           | 2/1987  | Matsubara et al.    |
| 4,695,948 A           | 9/1987  | Blevins et al.      |
| 4,697,232 A           | 9/1987  | Brunelle et al.     |
| 4,715,030 A           | 12/1987 | Koch et al.         |
| 4,751,635 A           | 6/1988  | Kret                |
| 4,787,028 A           | 11/1988 | Finfrock et al.     |
| 4,807,180 A           | 2/1989  | Takeuchi et al.     |
| 4,811,278 A           | 3/1989  | Bean et al.         |
| 4,821,179 A           | 4/1989  | Jensen et al.       |
| 4,825,406 A           | 4/1989  | Bean et al.         |
| 4,827,411 A           | 5/1989  | Arrowood et al.     |
| 4,835,674 A           | 5/1989  | Collins et al.      |
| 4,845,722 A           | 7/1989  | Kent et al.         |
| 4,864,532 A           | 9/1989  | Reeve et al.        |
| 4,897,874 A           | 1/1990  | Lidensky et al.     |
| 4,947,367 A           | 8/1990  | Chang et al.        |
| 4,961,224 A           | 10/1990 | Yung                |
| 5,072,378 A           | 12/1991 | Manka               |
| 5,077,732 A           | 12/1991 | Fischer et al.      |
| 5,077,736 A           | 12/1991 | Dunphy, Jr. et al.  |
| 5,124,987 A           | 6/1992  | Milligan et al.     |
| 5,155,845 A           | 10/1992 | Beal et al.         |
| 5,163,131 A           | 11/1992 | Row et al.          |
| 5,185,876 A           | 2/1993  | Nguyen et al.       |
| 5,193,168 A           | 3/1993  | Corrigan et al.     |
| 5,193,184 A           | 3/1993  | Belsan et al.       |
| 5,202,856 A           | 4/1993  | Glider et al.       |
| 5,210,866 A           | 5/1993  | Milligan et al.     |
| 5,212,785 A           | 5/1993  | Powers et al.       |
| 5,214,778 A           | 5/1993  | Glider et al.       |
| 5,226,143 A           | 7/1993  | Baird et al.        |
| 5,239,632 A           | 8/1993  | Larner              |
| 5,239,643 A           | 8/1993  | Blount et al.       |
| 5,239,654 A           | 8/1993  | Ing-Simmons et al.  |
| 5,247,638 A           | 9/1993  | O'Brien et al.      |
| 5,247,692 A           | 9/1993  | Fujimura            |
| 5,257,386 A           | 10/1993 | Saito               |
| 5,297,262 A           | 3/1994  | Cox et al.          |
| 5,301,290 A           | 4/1994  | Tetzlaff et al.     |
| 5,315,657 A           | 5/1994  | Abadi et al.        |
| 5,317,693 A           | 5/1994  | Elko et al.         |
| 5,331,673 A           | 7/1994  | Elko et al.         |
| 5,347,384 A           | 9/1994  | McReynolds et al.   |
| 5,355,453 A           | 10/1994 | Glider et al.       |
| 5,361,347 A           | 11/1994 | Glider et al.       |
| 5,367,646 A           | 11/1994 | Pardillos et al.    |
| 5,379,385 A           | 1/1995  | Shomler             |
| 5,379,398 A           | 1/1995  | Cohn et al.         |
| 5,388,243 A           | 2/1995  | Glider et al.       |
| 5,388,246 A           | 2/1995  | Kasi                |
| 5,394,402 A           | 2/1995  | Ross et al.         |
| 5,394,526 A           | 2/1995  | Crouse et al.       |
| 5,396,596 A           | 3/1995  | Hashemi et al.      |
| 5,403,639 A           | 4/1995  | Belsan et al.       |
| 5,410,667 A           | 4/1995  | Belsan et al.       |
| 5,410,697 A           | 4/1995  | Baird et al.        |
| 5,414,820 A           | 5/1995  | McFarland et al.    |
| 5,416,915 A           | 5/1995  | Mattson et al.      |
| 5,418,909 A           | 5/1995  | Jachowski et al.    |
| 5,420,988 A           | 5/1995  | Elliott             |
| 5,423,026 A           | 6/1995  | Cook et al.         |
| 5,423,044 A           | 6/1995  | Sutton et al.       |
| 5,426,637 A           | 6/1995  | Derby et al.        |
| 5,430,855 A           | 7/1995  | Wash et al.         |
| 5,450,570 A           | 9/1995  | Richeck et al.      |
| 5,452,421 A           | 9/1995  | Beardsley et al.    |
| 5,459,857 A           | 10/1995 | Ludlam et al.       |
| 5,463,754 A           | 10/1995 | Beausoleil et al.   |
| 5,465,382 A           | 11/1995 | Day, III et al.     |
| 5,469,576 A           | 11/1995 | Dauerer et al.      |
| 5,471,609 A           |         |                     |
| 5,487,077 A           |         |                     |
| 5,491,812 A           |         |                     |
| 5,495,474 A           |         |                     |
| 5,496,576 A           |         |                     |
| 5,504,857 A           |         |                     |
| 5,507,032 A           |         |                     |
| 5,511,169 A           |         |                     |
| 5,519,695 A           |         |                     |
| 5,530,845 A           |         |                     |
| 5,535,352 A           |         |                     |
| 5,537,585 A           |         |                     |
| 5,544,313 A           |         |                     |
| 5,548,791 A           |         |                     |
| 5,564,019 A           |         |                     |
| 5,568,648 A           |         |                     |
| 5,581,709 A           |         |                     |
| 5,581,714 A           |         |                     |
| 5,581,724 A           |         |                     |
| 5,596,562 A           |         |                     |
| 5,596,736 A           |         |                     |
| 5,598,541 A           |         |                     |
| 5,613,082 A           |         |                     |
| 5,621,902 A           |         |                     |
| 5,632,012 A           |         |                     |
| 5,634,111 A           |         |                     |
| 5,638,518 A           |         |                     |
| 5,642,515 A           |         |                     |
| 5,659,756 A           |         |                     |
| 5,664,107 A           |         |                     |
| 5,680,556 A           |         |                     |
| 5,684,800 A           |         |                     |
| 5,701,491 A           |         |                     |
| 5,712,976 A           |         |                     |
| 5,727,218 A           |         |                     |
| 5,729,705 A           |         |                     |
| 5,743,847 A           |         |                     |
| 5,748,924 A           |         |                     |
| 5,751,971 A           |         |                     |
| 5,751,975 A           |         |                     |
| 5,764,931 A           |         |                     |
| 5,768,623 A           |         |                     |
| 5,774,683 A           |         |                     |
| 5,778,411 A           |         |                     |
| 5,781,715 A           |         |                     |
| 5,802,278 A           |         |                     |
| 5,805,816 A           |         |                     |
| 5,805,920 A           |         |                     |
| 5,809,328 A           |         |                     |
| 5,812,754 A           |         |                     |
| 5,819,054 A           |         |                     |
| 5,825,772 A           |         |                     |
| 5,835,496 A           |         |                     |
| 5,845,107 A           |         |                     |
| 5,848,251 A           |         |                     |
| 5,857,080 A           |         |                     |
| 5,860,137 A           |         |                     |
| 5,864,653 A           |         |                     |
| 5,867,648 A           |         |                     |
| 5,884,027 A           |         |                     |
| 5,889,952 A           |         |                     |
| 5,913,045 A           |         |                     |
| 5,923,557 A           |         |                     |
| 5,933,824 A           |         |                     |
| 5,935,205 A           |         |                     |
| 5,935,260 A           |         |                     |
| 5,941,969 A           |         |                     |
| 5,941,972 A           |         |                     |
| 5,946,308 A           |         |                     |
| 5,953,511 A           |         |                     |
| 5,959,994 A           |         |                     |
| 5,963,556 A           |         |                     |
| 5,974,530 A           |         |                     |
| 5,978,379 A           |         |                     |
| 5,978,875 A           |         |                     |
| 5,991,797 A           |         |                     |
| 6,000,020 A           |         |                     |
| 6,021,451 A           |         |                     |
| 6,029,168 A           |         |                     |
| 11/1995               |         | Yudenfriend et al.  |
| 1/1996                |         | Hassner et al.      |
| 2/1996                |         | Pisello et al.      |
| 2/1996                |         | Olnowich et al.     |
| 3/1996                |         | Jeong               |
| 4/1996                |         | Baird et al.        |
| 4/1996                |         | Kimura              |
| 4/1996                |         | Suda                |
| 5/1996                |         | Purohit et al.      |
| 6/1996                |         | Hiatt et al.        |
| 7/1996                |         | Bridges et al.      |
| 7/1996                |         | Blickerstaff et al. |
| 8/1996                |         | Shachnai et al.     |
| 8/1996                |         | Casper et al.       |
| 10/1996               |         | Beausoleil et al.   |
| 10/1996               |         | Coscarella et al.   |
| 12/1996               |         | Ito et al.          |
| 12/1996               |         | Amini et al.        |
| 12/1996               |         | Belsan et al.       |
| 1/1997                |         | Chen                |
| 1/1997                |         | Kerns               |
| 1/1997                |         | Malladi             |
| 3/1997                |         | Brewer et al.       |
| 4/1997                |         | Cases et al.        |
| 5/1997                |         | Belsan et al.       |
| 5/1997                |         | Oeda et al.         |
| 6/1997                |         | Malladi             |
| 6/1997                |         | Jones et al.        |
| 8/1997                |         | Hefferon et al.     |
| 9/1997                |         | Chatwanni et al.    |
| 10/1997               |         | Begun et al.        |
| 11/1997               |         | Dobbins et al.      |
| 12/1997               |         | Dunn et al.         |
| 1/1998                |         | Falcon et al.       |
| 3/1998                |         | Hotchkin            |
| 3/1998                |         | Weber               |
| 4/1998                |         | Nakamura et al.     |
| 5/1998                |         | Llorens et al.      |
| 5/1998                |         | Dobbins et al.      |
| 5/1998                |         | Gillespie et al.    |
| 6/1998                |         | Schmahl et al.      |
| 6/1998                |         | Judd et al.         |
| 6/1998                |         | Gulick              |
| 7/1998                |         | DeMoss              |
| 7/1998                |         | Sheu                |
| 9/1998                |         | Isfeld et al.       |
| 9/1998                |         | Picazo, Jr. et al.  |
| 9/1998                |         | Sprenkle et al.     |
| 9/1998                |         | Nogales et al.      |
| 9/1998                |         | Lui et al.          |
| 10/1998               |         | Ninomiya et al.     |
| 10/1998               |         | Dobbins et al.      |
| 11/1998               |         | Yeung et al.        |
| 12/1998               |         | Fisch et al.        |
| 12/1998               |         | Lomelino et al.     |
| 1/1999                |         | Jander et al.       |
| 1/1999                |         | Raz et al.          |
| 1/1999                |         | Tavallaei et al.    |
| 2/1999                |         | Foth et al.         |
| 3/1999                |         | Garbus et al.       |
| 3/1999                |         | Hunnicut et al.     |
| 6/1999                |         | Gillespie et al.    |
| 7/1999                |         | Eidson              |
| 8/1999                |         | DeKoning et al.     |
| 8/1999                |         | Murayama et al.     |
| 8/1999                |         | Ofer                |
| 8/1999                |         | Ram et al.          |
| 8/1999                |         | Hoese et al.        |
| 8/1999                |         | Dobbins et al.      |
| 9/1999                |         | Sescilia et al.     |
| 9/1999                |         | Boggs et al.        |
| 10/1999               |         | Varghese et al.     |
| 10/1999               |         | Young               |
| 11/1999               |         | Chan et al.         |
| 11/1999               |         | Asano et al.        |
| 11/1999               |         | Futral et al.       |
| 12/1999               |         | Chin et al.         |
| 2/2000                |         | Bell et al.         |
| 2/2000                |         | Frey                |



## US 7,934,041 B2

Page 3

|   |            |         |                       |    |                |         |
|---|------------|---------|-----------------------|----|----------------|---------|
| 6,032,269   | A          | 2/2000  | Renner, Jr.           | IL | 107645         | 9/1996  |
| 6,041,058   | A          | 3/2000  | Flanders et al.       | JP | 5502525        | 4/1993  |
| 6,041,381   | A          | 3/2000  | Hoese                 | JP | 5181609        | 7/1993  |
| 6,055,603   | A          | 4/2000  | Ofer et al.           | JP | 1993181609     | 7/1993  |
| 6,065,087   | A          | 5/2000  | Keaveny et al.        | JP | 6301607        | 10/1994 |
| 6,070,253   | A          | 5/2000  | Tavallaei et al.      | JP | 720994         | 1/1995  |
| 6,073,209   | A          | 6/2000  | Bergsten              | JP | 1995020994     | 1/1995  |
| 6,073,218   | A          | 6/2000  | DeKoning et al.       | JP | 8-230895       | 9/1996  |
| 6,075,863   | A          | 6/2000  | Krishnan et al.       | JP | 1997185594     | 7/1997  |
| 6,081,849   | A          | 6/2000  | Born et al.           | JP | 1997251437     | 9/1997  |
| 6,098,128   | A          | 8/2000  | Velez-McCaskey et al. | JP | 10097493       | 4/1998  |
| 6,098,149   | A          | 8/2000  | Ofer et al.           | WO | WO 91/03788    | 3/1991  |
| 6,108,684   | A          | 8/2000  | DeKoning et al.       | WO | WO 98/36357    | 8/1998  |
| 6,118,766   | A          | 9/2000  | Akers                 | WO | WO 9733227     | 8/1998  |
| 6,131,119   | A          | 10/2000 | Fukui                 | WO | WO 99/34297 A1 | 7/1999  |
| 6,134,617   | A          | 10/2000 | Weber                 |    |                |         |
| 6,141,737   | A          | 10/2000 | Krantz et al.         |    |                |         |
| 6,145,006   | A          | 11/2000 | Vishlitsky et al.     |    |                |         |
| 6,147,976   | A          | 11/2000 | Shand et al.          |    |                |         |
| 6,147,995   | A          | 11/2000 | Dobbins et al.        |    |                |         |
| 6,148,004   | A          | 11/2000 | Nelson et al.         |    |                |         |
| 6,173,399   | B1         | 1/2001  | Gilbrech              |    |                |         |
| 6,185,203   | B1         | 2/2001  | Berman                |    |                |         |
| 6,202,153   | B1         | 3/2001  | Diamant et al.        |    |                |         |
| 6,209,023   | B1         | 3/2001  | Dimitroff et al.      |    |                |         |
| 6,219,771   | B1         | 4/2001  | Kikuchi et al.        |    |                |         |
| 6,223,266   | B1         | 4/2001  | Sartore               |    |                |         |
| 6,230,218   | B1         | 5/2001  | Casper et al.         |    |                |         |
| 6,243,827   | B1         | 6/2001  | Renner, Jr.           |    |                |         |
| 6,260,120   | B1         | 7/2001  | Blumenau et al.       |    |                |         |
| 6,268,789   | B1         | 7/2001  | Diamant et al.        |    |                |         |
| 6,308,247   | B1         | 10/2001 | Ackerman              |    |                |         |
| 6,330,629   | B1         | 12/2001 | Kondo et al.          |    |                |         |
| 6,330,687   | B1         | 12/2001 | Griffith              |    |                |         |
| 6,341,315   | B1         | 1/2002  | Arroyo et al.         |    |                |         |
| 6,343,324   | B1         | 1/2002  | Hubis et al.          |    |                |         |
| 6,363,462   | B1         | 3/2002  | Bergsten              |    |                |         |
| 6,401,170   | B1         | 6/2002  | Griffith et al.       |    |                |         |
| 6,421,753   | B1         | 7/2002  | Hoese et al.          |    |                |         |
| 6,425,035   | B2         | 7/2002  | Hoese et al.          |    |                |         |
| 6,425,036   | B2         | 7/2002  | Hoese et al.          |    |                |         |
| 6,425,052   | B1         | 7/2002  | Hashemi               |    |                |         |
| 6,453,345   | B2         | 9/2002  | Trcka et al.          |    |                |         |
| 6,484,245   | B1         | 11/2002 | Sanada et al.         |    |                |         |
| D470,486  | S          | 2/2003  | Cheng                 |    |                |         |
| 6,529,996   | B1         | 3/2003  | Nguyen et al.         |    |                |         |
| 6,547,576   | B2         | 4/2003  | Peng et al.           |    |                |         |
| 6,560,750   | B2         | 5/2003  | Chien et al.          |    |                |         |
| 6,563,701   | B1         | 5/2003  | Peng et al.           |    |                |         |
| 6,775,693   | B1         | 8/2004  | Adams                 |    |                |         |
| 6,792,602   | B2         | 9/2004  | Lin et al.            |    |                |         |
| 6,820,212   | B2         | 11/2004 | Duchesne et al.       |    |                |         |
| 6,854,027   | B2         | 2/2005  | Hsu et al.            |    |                |         |
| 6,862,637   | B1         | 3/2005  | Stupar                |    |                |         |
| 6,874,043   | B2         | 3/2005  | Treggiden             |    |                |         |
| 6,874,100   | B2         | 3/2005  | Rauscher              |    |                |         |
| 6,910,083   | B2         | 6/2005  | Hsu et al.            |    |                |         |
| 7,065,076   | B1         | 6/2006  | Nemazie               |    |                |         |
| 7,127,668   | B2         | 10/2006 | McBryde et al.        |    |                |         |
| 7,133,965   | B2         | 11/2006 | Chien                 |    |                |         |
| 7,188,111   | B2         | 3/2007  | Chen et al.           |    |                |         |
| 7,216,225   | B2         | 5/2007  | Haviv et al.          |    |                |         |
| 7,251,248   | B2         | 7/2007  | Trossell et al.       |    |                |         |
| 7,281,072   | B2         | 10/2007 | Liu et al.            |    |                |         |
| 2002/0083221  | A1         | 6/2002  | Tsai et al.           |    |                |         |
| 2006/0218322  | A1         | 9/2006  | Hoese et al.          |    |                |         |
| 2006/0277326  | A1         | 12/2006 | Tsai et al.           |    |                |         |
| 2006/0294416  | A1         | 12/2006 | Tsai et al.           |    |                |         |
| FOREIGN PATENT DOCUMENTS  |            |         |                       |    |                |         |
| AU  | 670376     | 7/1996  |                       |    |                |         |
| CA  | 2066443    | 10/2003 |                       |    |                |         |
| EP  | 0810530 A2 | 12/1997 |                       |    |                |         |
| EP  | 0490973    | 2/1998  |                       |    |                |         |
| EP  | 0827059 A2 | 3/1998  |                       |    |                |         |
| GB  | 2296798 A  | 7/1996  |                       |    |                |         |
| GB  | 2297636 A  | 8/1996  |                       |    |                |         |
| GB  | 2341715    | 3/2000  |                       |    |                |         |
| IL  | 095447     | 5/1994  |                       |    |                |         |
| OTHER PUBLICATIONS  |            |         |                       |    |                |         |
| Block-Based Distributed File Systems, Anthony J. McGregor, Jul. 1997.   |            |         |                       |    |                |         |
| Compaq StorageWorks HSG80 Array Controller ACS Version 8.3 (Maintenance and Service Guide) Nov. 1998.   |            |         |                       |    |                |         |
| Compaq StorageWorks HSG80 Array Controller ACS Version 8.3 (Configuration and CLI Reference Guide) Nov. 1998.   |            |         |                       |    |                |         |
| CRD-5500, Raid Disk Array Controller Product Insert, pp. 1-5.   |            |         |                       |    |                |         |
| CRD-5500, SCSI Raid Controller OEM Manual, Rev. 1.3, Feb. 26, 1996, pp. 1-54.   |            |         |                       |    |                |         |
| CRD-5500, SCSI Raid Controller Users Manual, Rev. 1.3, Nov. 21, 1996, pp. 10-92.  |            |         |                       |    |                |         |
| Digital StorageWorks HSZ70 Array Controller HSOF Version 7.0 EK-SHZ70-RM.A01 CLI Reference Manual, Jul. 1, 1997.  |            |         |                       |    |                |         |
| Digital Storage Works, HSZ70 Array Controller, HSOF Version 7.0 EK-HSZ70-CG. A01, Digital Equipment Corporation, Maynard, Massachusetts, Jul. 1, 1997.              |            |         |                       |    |                |         |
| Digital StorageWorks, Using Your HSZ70 Array Controller in a SCSI Controller Shelf (DS-BA356-M Series), User's Guide, pp. 1-1 through A-5 with index, Jan. 1, 1998. |            |         |                       |    |                |         |
| Digital StorageWorks HSZ70 Array Controller HSOF Version 7.0 EK-HSZ70-SV.A01, 1997.   |            |         |                       |    |                |         |
| Digital StorageWorks HSG80 Array Controller ACS Version 8.0 (User's Guide) Jan. 1998.   |            |         |                       |    |                |         |
| DP5380 Asynchronous SCSI Interface, National Semiconductor Corporation, Arlington, TX, May 1989, pp. 1-32.  |            |         |                       |    |                |         |
| Emerson, "Encor Communications: Performance evaluation of switched fibre channel I/O system using—FCP for SCSI", IEEE, pp. 479-484, Feb. 1, 1995.                   |            |         |                       |    |                |         |
| Fiber channel (FCS)/ATM internetworking: a design solution.   |            |         |                       |    |                |         |
| Fiber Channel storage interface for video-on-demand servers by Anazaloni, et al., Jun. 15, 1995.  |            |         |                       |    |                |         |
| Fibre Channel and ATM: The Physical Layers, Jerry Quam WESCON/94, published Sep. 27-29, 1994, pp. 648-652.  |            |         |                       |    |                |         |
| Gen5 S-Series XL System Guide Revision 1.01 by Chen, Jun. 18, 1995.   |            |         |                       |    |                |         |
| Graphical User Interface for MAXSTRAT Gen5/Gen-S Servers User's guide 1.1, Jun. 11, 1996.   |            |         |                       |    |                |         |
| High Performance Data transfers Using Network-Attached Peripherals at the national Storage Laboratory by Hyer, Feb. 26, 1993.                                       |            |         |                       |    |                |         |
| IFT-3000 SCSI to SCSI Disk array Controller Instruction Manual Revision 2.0 by Infotrend Technologies, Inc. 1995.   |            |         |                       |    |                |         |
| Implementing a Fibre Channel SCSI transport by Snively, 1994.   |            |         |                       |    |                |         |
| "InfoServer 150—Installation and Owner's Guide", EK-INFSV-OM-001, Digital Equipment Corporation, Maynard, Massachusetts 1991, Chapters 1 and 2.                     |            |         |                       |    |                |         |
| InfoServer 150VXT Photograph.   |            |         |                       |    |                |         |
| IBM Technical Publication: Guide to Sharing and Partitioning IBM Tape Library Dataservers, pp. 1-256, Nov. 1, 1996.   |            |         |                       |    |                |         |
| IBM Technical Publication: Magstar and IBM 3590 High Performance Tape Subsystem Technical Guide, pp. 1-269, Nov. 1, 1996.   |            |         |                       |    |                |         |
| Misc. Reference Manual Pages, SunOS 5.09.   |            |         |                       |    |                |         |
| InfoServer 100 System Operations Guide, First Edition Digital Equipment Corporation, 1990.  |            |         |                       |    |                |         |
| Johnson, D.B., et al., The Peregrine High Performance RPC System, Software-Practice and Experience, 23(2):201-221, Feb. 1993.                                       |            |         |                       |    |                |         |
| Local-Area networks for the IBM PC by Haugdahl.   |            |         |                       |    |                |         |



## US 7,934,041 B2

Page 4

New serial I/Os speed storage subsystems by Bursky, Feb. 6, 1995.

Petal: Distributed Virtual Disks, Edward K. Lee and Chandramohan A. Thekkath, ACM SIGPLAN Notices, vol. 31, Issue 9, Sep. 1996, pp. 84-92.

Pictures of internal components of the InfoServer 150, taken from <http://bindarydinosaurs.couk/Museum/Digital/infoserver/infoserver.php> in Nov. 2004.

Raidtec FibreArray and Raidtec FlexArray UltraRAID Systems, Windows IT PRO Article, Oct. 1997.

S.P. Joshi, "Ethernet controller chip interfaces with variety of 16-bit processors," electronic Design, Hayden Publishing Co., Inc., Rochelle Park, NJ, Oct. 14, 1982, pp. 193-200.

Simplest Migration to Fibre Channel Technology Article, Digital Equipment Corporation, Nov. 10, 1997, published on PR Newswire.

Systems Architectures Using Fibre Channel, Roger Cummings, Twelfth IEEE Symposium on Mass Storage Systems, Copyright 1993 IEEE, pp. 251-256.

Office Action dated Jan. 21, 2003 for U.S. Appl. No. 10/174,720.

Office Action dated Feb. 27, 2001 for U.S. Appl. No. 09/354,682.

Office Action dated Aug. 11, 2000 for U.S. Appl. No. 09/354,682.

Office Action dated Dec. 16, 1999 for U.S. Appl. No. 09/354,682.

Office Action dated Nov. 6, 2002 for U.S. Appl. No. 10/023,786.

Office Action dated Jan. 21, 2003 for U.S. Appl. No. 10/081,110.

Office Action in Ex Parte Reexamination 90/007,127, mailed Feb. 7, 2005.

Office Action in Ex Parte Reexamination 90/007,125, mailed Feb. 7, 2005.

Office Action in Ex Parte Reexamination 90/007,126, mailed Feb. 7, 2005.

Office Action in Ex Parte Reexamination 90/007,124, mailed Feb. 7, 2005.

Office Action in Ex Parte Reexamination 90/007,123, mailed Feb. 7, 2005.

European Office Action issued Apr. 1, 2004 in Application No. 98966104.6-2413.

Office Action dated Jan. 27, 2005 in U.S. Appl. No. 10/658,163.

Digital "System Support Addendum", SSA 40.78.01-A, AE-PNZJB-TE, pp. 1-3, Apr. 1, 1993.

Digital "Software Product Description", SSA 40.78.01, AE-PNZJB-TE, pp. 1-3, Apr. 1, 1993.

Digital Equipment Corporation, "InfoServer 100 Installation and Owner's Guide", Order No. EK-DIS1K-IN-001, First Edition, Oct. 1, 1990.

Digital Equipment Corporation, "InfoServer 100 System Operation Guide", Order No. EK-DIS1K-UG-001, First Edition, pp. i-Index 5, Oct. 1, 1990.

Elliott, Working Draft American National Standard, Project T10/1562-D, Revision 5, pp. i-432, Jul. 9, 2003.

Satran, "Standards-Track," May 2001, iSCSI, pp. 9-87, Nov. 1, 2000.

Satran, et al. IPS Internet Draft, iSCSI, pp. 1-8, Nov. 1, 2000.

APT Technologies, Inc., "Serial ATA: High Speed Serialized AT Attachment", Rev. 1.0a, pp. 1-310, Jan. 7, 2003.

Defendant's First Supplemental Trial Exhibit List, *Crossroads Systems, Inc. v. Chaparral Network Storage, Inc.*, C.A. No. A-00CA-217-SS (W.D. Tex. 2001). (CD-Rom).

Defendant's Third Supplemental Trial Exhibit List, *Crossroads Systems, Inc. v. Pathlight Technology, Inc.*, C.A. No. A-00CA-248-SS (W.D. Tex. 2001) (CD-Rom).

Plaintiff's Fourth Amended Trial Exhibit List, *Crossroads Systems, Inc. v. Chaparral Network Storage, Inc.*, C.A. No. A-00CA-217-SS (W.D. Tex. 2001) (CD-Rom).

Plaintiff's Revised Trial Exhibit List, *Crossroads Systems, Inc. v. Pathlight Technology, Inc.*, C.A. No. A-00CA-248-SS (W.D. Tex. 2001). (CD-Rom).

Trail Transcripts, *Crossroads Systems, Inc. v. Chaparral Network Storage, Inc.*, C.A. No. A-00CA-217-SS (W.D. Tex. 2001) Day 1-5 (CD-Rom).

Trail Transcripts, *Crossroads Systems, Inc. v. Pathlight Technology, Inc.*, C.A. No. A-00CA-248-SS (W.D. Tex. 2001). Day 1-4 (CD-Rom).

Datasheet for CrossPoint 4100 Fibre Channel to SCSI Router (Dedek Ex 41 (ANCT 117-120)) (CD-ROM Chaparral Exhibits D012).

Symbios Logic- Software Interface Specification Series 3 SCSI RAID Controller Software Release 02.xx (Engelbrecht Ex 2 (LSI 1421-1658)) (CD-ROM Chaparral Exhibits D013), Dec. 3, 1997.

Press Release- Symbios Logic to Demonstrate Strong Support for Fibre Channel at Fall Comdex (Engelbrecht 12 (LSI 2785-86)) (CD-ROM Chaparral Exhibits D016), Nov. 13, 1996.

OEM Datasheet on the 3701 Controller (Engelbrecht 13 (LSI 01837-38)) (CD-ROM Chaparral Exhibits D017), Jun. 17, 1995.

Nondisclosure Agreement Between Adaptec and Crossroads Dated Oct. 17, 1996 (Quisenberry Ex 25 (CRDS 8196)) (CD-ROM Chaparral Exhibits D020), Oct. 17, 1996.

Organizational Presentation on the External Storage Group (Lavan Ex 1 (CNS 182242-255)) (CD-ROM Chaparral Exhibits D021), Apr. 11, 1996.

Bridge Phase II Architecture Presentation (Lavan Ex 2 (CNS 182287-295)) (CD-ROM Chaparral Exhibits D022), Apr. 12, 1996.

Bridge. C, Bridge Between SCSI-2 and SCSI-3 FCP (Fibre Channel Protocol) (CD-ROM Chaparral Exhibits P214).

Attendees/Action Items from Apr. 12, 1996 Meeting at BTC (Lavan Ex 3 (CNS 182241)) (CD-ROM Chaparral Exhibits D023), Apr. 12, 1996.

Brooklyn Hardware Engineering Requirements Documents, Revision 1.4 (Lavan Ex 4 (CNS 178188-211)) (CD-ROM Chaparral Exhibits D024) by Pecone, May 26, 1996.

Brooklyn Single-Ended SCSI RAID Bridge Controller Hardware OEM Manual, Revision 2.1 (Lavan Ex 5 (CNS 177169-191)) (CD-ROM Chaparral Exhibits D025), Mar. 2, 1996.

Coronado Hardware Engineering Requirements Document, Revision 0.0 (Lavan Ex 7 (CNS 176917-932)) (CD-ROM Chaparral Exhibits D027) by O'Dell, Sep. 30, 1996.

ESS/FPG Organization (Lavan Ex 8 (CNS 178639-652)) (CD-ROM Chaparral Exhibits D028), Dec. 6, 1996.

Adaptec MCS ESS Presents: Intelligent External I/O Raid Controllers "Bridge" Strategy (Lavan Ex 9 (CNS 178606-638)). (CD-ROM Chaparral Exhibits D029), Feb. 6, 1996.

AEC-7313 Fibre Channel Daughter Board (for Brooklyn) Engineering Specification, Revision 1.0 (Lavan Ex 10 (CNS 176830-850)) (CD-ROM Chaparral Exhibits D030), Feb. 27, 1997.

Bill of Material (Lavan Ex 14 (CNS 177211-214)) (CD-ROM Chaparral Exhibits D034), Jul. 24, 1997.

AEC-. 4412B, AEC-7412/B2 External RAID Controller Hardware OEM Manual, Revision 2.0 (Lavan Ex 15 (CNS 177082-123)) (CD-ROM Chaparral Exhibits D035), Jun. 27, 1997.

Coronado II, AEC-7312A Fibre Channel Daughter (for Brooklyn) Hardware Specification, Revision 1.2 (Lavan Ex 16 (CNS 177192-210)) (CD-ROM Chaparral Exhibits D036) by Tom Yang, Jul. 18, 1997.

AEC-4412B, AEC7412/3B External RAID Controller Hardware OEM Manual, Revision 3.0. (Lavan Ex 17 (CNS 177124-165)) (CD-ROM Chaparral Exhibits D037), Aug. 25, 1997.

Memo Dated Aug. 15, 1997 to AEC-7312A Evaluation Unit Customers re: B001 Release Notes (Lavan Ex 18 (CNS 182878-879)) (CD-ROM Chaparral Exhibits D038), Aug. 15, 1997.

Brooklyn Main Board (AES-0302) MES Schedule (Lavan Ex 19 (CNS 177759-763)) (CD-ROM Chaparral Exhibits D039), Feb. 11, 1997.

News Release-Adaptec Adds Fibre Channel Option to its External RAID Controller Family (Lavan Ex 20 (CNS 182932-934)) (CD-ROM Chaparral Exhibits D040), May 6, 1997.

AEC-4412B/7412B User's Guide, Rev. A (Lavan Ex 21) (CD-ROM Chaparral Exhibits D041), Jun. 19, 1995.

Data Book- AIC-7895 PCI Bus Master Single Chip SCSI Host Adapter (Davies Ex 1 (CNS 182944-64)) (CD-ROM Chaparral Exhibits D046), May 21, 1996.

Data Book- AIC-1160 Fibre Channel Host Adapter ASIC (Davies Ex 2 (CNS 181800-825)) (CD-ROM Chaparral Exhibits D047), Jun. 18, 1995.

Viking RAID Software (Davies Ex 3 (CNS 180969-181026)) (CD-ROM Chaparral Exhibits D048), Jun. 18, 1995.

Header File with Structure Definitions (Davies Ex 4 (CNS 180009-018)) (CD-ROM Chaparral Exhibits D049), Aug. 8, 1996.



## US 7,934,041 B2

Page 5

C++ SourceCode for the SCSI Command Handler (Davies Ex 5 (CNS 179136-168)) (CD-ROM Chaparral Exhibits D050), Aug. 8, 1996.

Header File Data Structure (Davies Ex 6 (CNS 179997-180008)) (CD-ROM Chaparral Exhibits D051), Jan. 2, 1997.

SCSI Command Handler (Davies Ex 7 (CNS 179676-719)) (CD-ROM Chaparral Exhibits D052), Jan. 2, 1997.

Coronado: Fibre Channel to SCSI Intelligent RAID Controller Product Brief (Kalwitz Ex I (CNS 182804-805)) (CD-ROM Chaparral Exhibits D053).

Bill of Material (Kalwitz Ex 2 (CNS 181632-633)) (CD-ROM Chaparral Exhibits D054), Mar. 17, 1997.

Emails Dated Jan. 13-Mar. 31, 1997 from P. Collins to Mo re: Status Reports (Kalwitz Ex 3 (CNS 182501-511)) (CD-ROM Chaparral Exhibits D055).

Hardware Schematics for the Fibre Channel Daughtercard Coronado (Kalwitz Ex 4 (CNS 181639-648)) (CD-ROM Chaparral Exhibits D056).

Adaptec Schematics re AAC-340 (Kalwitz Ex 14 CNS 177215-251)) (CD-ROM Chaparral Exhibits D057).

Bridge Product Line Review (Manzanares Ex 3 (CNS 177307-336)) (CD-ROM Chaparral Exhibits D058).

AEC Bridge Series Products-Adaptec External Controller RAID Products Pre-Release Draft, v.6 (Manzanares Ex 4 (CNS 174632-653)) (CD-ROM Chaparral Exhibits D059), Oct. 28, 1997.

Hewlett-Packard Roseville Site Property Pass for Brian Smith (Dunning Ex 14 (HP 489)) (CD-ROM Chaparral Exhibits D078), Nov. 7, 1996.

Distribution Agreement Between Hewlett-Packard and Crossroads (Dunning Ex 15 (HP 326-33)) (CD-ROM Chaparral Exhibits D079).

HPFC-5000 Tachyon User's Manual, First Edition (PTI 172419-839) (CD-ROM Chaparral Exhibits D084), May 1, 1996.

X3T10 994D—(Draft) Information Technology: SCSI-3 Architecture Model, Rev. 1.8 (PTI 165977) (CD-ROM Chaparral Exhibits D087).

X3T10 Project 1047D: Information Technology- SCSI-3 Controller Commands (SCC), Rev. 6c (PTI 166400-546) (CD-ROM Chaparral Exhibits D088), Sep. 3, 1996.

X3T10 995D- (Draft) SCSI-3 Primary Commands, Rev. 11 (Wanamaker Ex 5 (PTI 166050-229)) (CD-ROM Chaparral Exhibits D089), Nov. 13, 1996.

VBAR Volume Backup and Restore (CRDS 12200-202) (CD-ROM Chaparral Exhibits D099).

Preliminary Product Literature for Infinity Commstor's Fibre Channel to SCSI Protocol Bridge (Smith Ex 11; Quisenberry Ex 31 (SPLO 428-30) (CD-ROM Chaparral Exhibits D143), Aug. 19, 1996.

Letter dated Jul. 12, 1996 from J. Boykin to B. Smith re: Purchase Order for Evaluation Units from Crossroads (Smith Ex 24) CRDS 8556-57) (CD-ROM Chaparral Exhibits D144), Jul. 12, 1996.

CrossPoint 4100 Fibre Channel to SCSI Router Preliminary Datasheet (Hulsey Ex 9 (CRDS 16129-130)) (CD-ROM Chaparral Exhibits D145), Nov. 1, 1996.

CrossPoint 4400 Fibre Channel to SCSI Router Preliminary Datasheet (Bardach Ex. 9, Quisenberry Ex 33 (CRDS 25606-607)) (CD-ROM Chaparral Exhibits D153), Nov. 1, 1996.

Fax Dated Jul. 22, 1996 from L. Petti to B. Smith re: Purchase Order from Data General for FC2S Fibre to Channel SCSI Protocol Bridge Model 11 (Smith Ex 25; Quisenberry Ex 23; Bardach Ex 11 (CRDS 8552-55; 8558)) (CD-ROM Chaparral Exhibits D155), Jul. 22, 1996.

Email Dated Dec. 20, 1996 from J. Boykin to B. Smith re: Purchase Order for Betas in February and March (Hoese Ex 16, Quisenberry Ex 25; Bardach Ex 12 (CRDS 13644-650) (CD-ROM Chaparral Exhibits D156), Dec. 20, 1996.

Infinity Commstor Fibre Channel Demo for Fall Comdex, 1996 (Hoese Ex 15, Bardach Ex 13 (CRDS 27415) (CD-ROM Chaparral Exhibits D157).

Fax Dated Dec. 19, 1996 from B. Bardach to T. Rarich re: Purchase Order Information (Bardach Ex. 14; Smith Ex 16 (CRDS 4460)) (CD-ROM Chaparral Exhibits D158).

Miscellaneous Documents Regarding Comdex (Quisenberry Ex 2 (CRDS 27415-465)) (CD-ROM Chaparral Exhibits D165).

CrossPoint 4100 Fibre Channel to SCSI Router Preliminary Datasheet (Quisenberry) Ex 3 (CRDS 4933-34) (CD-ROM Chaparral Exhibits D166) (CD-ROM Chaparral Exhibits D166).

CrossPoint 4400 Fibre to Channel to SCSI Router Preliminary Datasheet; Crossroads Company and Product Overview (Quisenberry Ex 4 (CRDS 25606; 16136)) (CD-ROM Chaparral Exhibits D167).

Crossroads Purchase Order Log (Quisenberry Ex 9 (CRDS 14061-062)) (CD-ROM Chaparral Exhibits D172).

RAID Manager 5 with RDAC 5 for UNIX V.4 User's Guide (LSI-01854) (CD-ROM Chaparral Exhibits P062), Sep. 1, 1996.

Letter dated May 12, 1997 from Alan G. Leal to Barbara Bardach enclosing the original OEM License and Purchase Agreement between Hewlett-Packard Company and Crossroads Systems, Inc. (CRDS 02057) (CD-ROM Chaparral Exhibits P130).

CR4x00 Product Specification (CRDS 43929) (CD-ROM Chaparral Exhibits P267), Jun. 1, 1998.

Symbios Logic—Hardware Functional Specification for the Symbios Logic Series 3 Fibre Channel Disk Array Controller Model 3701 (Engelbrecht Ex 3 (LSI-1659-1733) (CD-ROM Pathlight Exhibits D074).

Report of the Working Group on Storage I/O for Large Scale Computing; Department of Computer Science Duke University: CS-1996-21 (PTI 173330-347). (CD-ROM Pathlight Exhibits D098).

Brian Allison's 1999 Third Quarter Sales Plan (PDX 38 ) (CNS 022120-132)) (CD-ROM Pathlight Exhibits D201), Jun. 5, 2001.

Brooklyn SCSI-SCSI Intelligent External RAID Bridge Definition Phase External Documentation ((CD-ROM Pathlight Exhibits D129).

StorageWorks HSx70 System Specification by Steve Sicola dated Jun. 11, 1996 4:57pm, Revision 4.

ANSI TR X3.xxx-199x, Revision 9 of X3-991D. Draft Proposed X3 Technical Report—Small Computer System Interface—3 Generic Packetized Protocol (SCSI-GPP). Computer and Business Equipment Manufacturers Assoc.

Enterprise Systems Connection (ESON) Implementation Guide, Jul. 1996, IBM International Technical Support Organization, Poughkeepsie Center, Jul. 1, 1996.

Digital Delivers Industry-Leading Enterprise-Class Storage Solutions. StorageWorks Family Provides Easiest Path to Fibre Channel. Three pages by Company News Oncall dated Sep. 9, 2004.

American National Standard for Information Technology—Fibre Channel Protocol for SCSI. ANSI X3.269-1996, Jun. 18, 1995.

F1710A File Control Unit and F6493 Array Disk Subsystem by Hitoshi Matsushima, Shojiro Okada and Tetsuro Kudo, Feb. 3, 1995.

The Legend of AMDAHL by Jeffrey L. Rodengen (5 pages).

Office Action dated Feb. 6, 2007 from the Japanese Patent Office regarding related application No. 526873/2000.

InfoServer 100 System Operation Guide, Order No. EK-DISK-UG-001.

iNFOSEVER 100 Installation and Owner's Guide, Order No. EK-DISK-IN-001.

Software Product Description: Product Name: InfoServer 100 Software, Version 1.1 SPD 38.59.00, Nov. 1, 1991.

Software Product Description: Product Name: InfoServer Client for ULTRIX, Version 1.1, SPD 40.78.01, Apr. 1, 1993.

Draft Proposed American National Standard. X3.269-199X, Revision 012. Information System—dpANS Fibre Channel Protocol fo SCSI, Dec. 4, 1995.

Impactdata Launches Breakthrough Architecture for Network Storage, Nov. 13, 1996.

Impactdata..News Release: Impactdata Introduces New Storage Architecture for High Performance Computing. 2 Pages, Nov. 12, 1996.

Impactdata..News Release: Impactdata's Network Peripheral Adapter (NPA) Pushes Technology Envelope of Data Storage Management in High-Speed Computing Environments. 2 Pages, Nov. 12, 1996.

Impactdata..News Release: Impactdata and Storage Concepts Announce Integration of FibreRAID II Storage Solution with Impactdata's Distributed Storage Node Architecture (DSNA). 2 pages, Nov. 18, 1996.

**US 7,934,041 B2**

Page 6

Impactdata...News Release: Breece Hill Libraries Now Able to Attach Directly to High Speed Networks Peripheral Adapter from Impactdata. 2 Pages, Nov. 20, 1996.  
Impactdata—DSNA Questions and Answers. 22 Pages.  
Impactdata—Network Storage Solutions. 4 pages.  
Network Storage Building Blocks. 2 Pages.  
Impactdata—NPA (Network Peripheral Interface). 4 Pages.  
Impactdata—CPI (Common Peripheral Interface). 2 Pages.  
Impactdata—SNC (Storage Node Controller). 2 Pages.  
Impactdata—DSNA (Distributed Storage Node Architecture) Protocol. 2 Pages.  
Impactdata—DS-50. 2 Pages.  
Impactdata—Corporate Fact Sheet. 1 Page.  
Raider-5 “Disk Array Manual for the UltraSCSI Controller”. Part No. 261-0013-002. 191 Pages.  
Impactdata—White Paper: Distributed Storage Node Architecture (DSNA). Jan. 1997.  
Impactdata—DSNA Distributed Storage Node Architecture “Reference Guide”. 44 Pages.  
F1710 Logic Specification.  
Translation of Final Office Action issued in JP 526873/2000 mailed May 14, 2008. 4 Pages.

Office Action issued in U.S. Appl. No. 11/851,837 dated Dec. 22, 2008, Hoese, 7 pages.  
English Translation of Japanese Laid-Open Publication No. 5-181609. 9 pgs., Jul. 23, 1993.  
English Translation of Japanese Laid-Open Publication No. 7-20994. 57 pgs. Jan. 24, 1995.  
F1710 File Control Unit (FCU) Logical Specifications. 11 Pages, Dec. 9, 1997.  
Questioning Mailed Jun. 8, 2010 from JP Patent Application 526873/2000. 8 pages.  
Office Action Mailed Aug. 17, 2010 in U.S. Appl. No. 11/947,499 to Hoese. 6 pgs.  
American National Standard for Information Systems: Fibre Channel—Cross-Point Switch Fabric Topology (FC-XS); X3T11/Project 959D/Rev 1.30. 114 pgs., Jun. 17, 1994.  
Office Action Mailed Sep. 13, 2010 in U.S. Appl. No. 11/980,909.  
Office Action Mailed Sep. 13, 2010 in U.S. Appl. No. 12/552,807.  
Office Action Mailed Sep. 15, 2010 in U.S. Appl. No. 12/552,885.  
Office Action Mailed Sep. 23, 2010 in U.S. Appl. No. 12/552,913.  
Office Action Mailed Dec. 2, 2010 in U.S. Appl. No. 12/910,375.  
Office Action Mailed Dec. 3, 2010 in U.S. Appl. No. 12/910,431.  
Office Action Mailed Dec. 3, 2010 in U.S. Appl. No. 12/910,515.



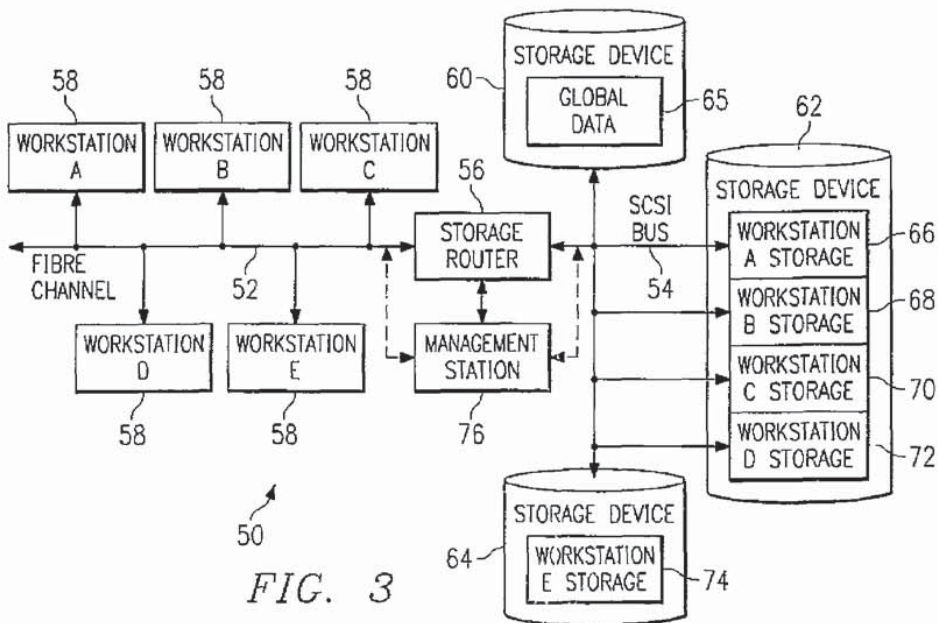
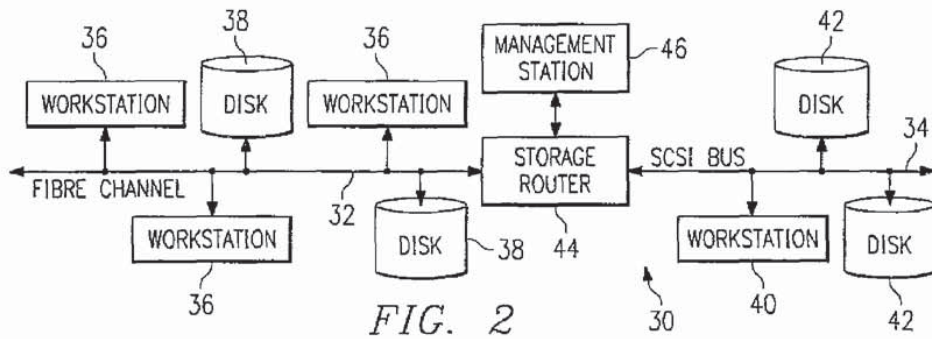
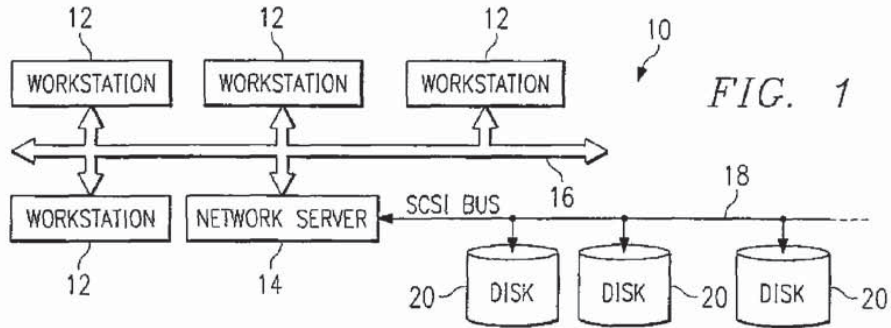

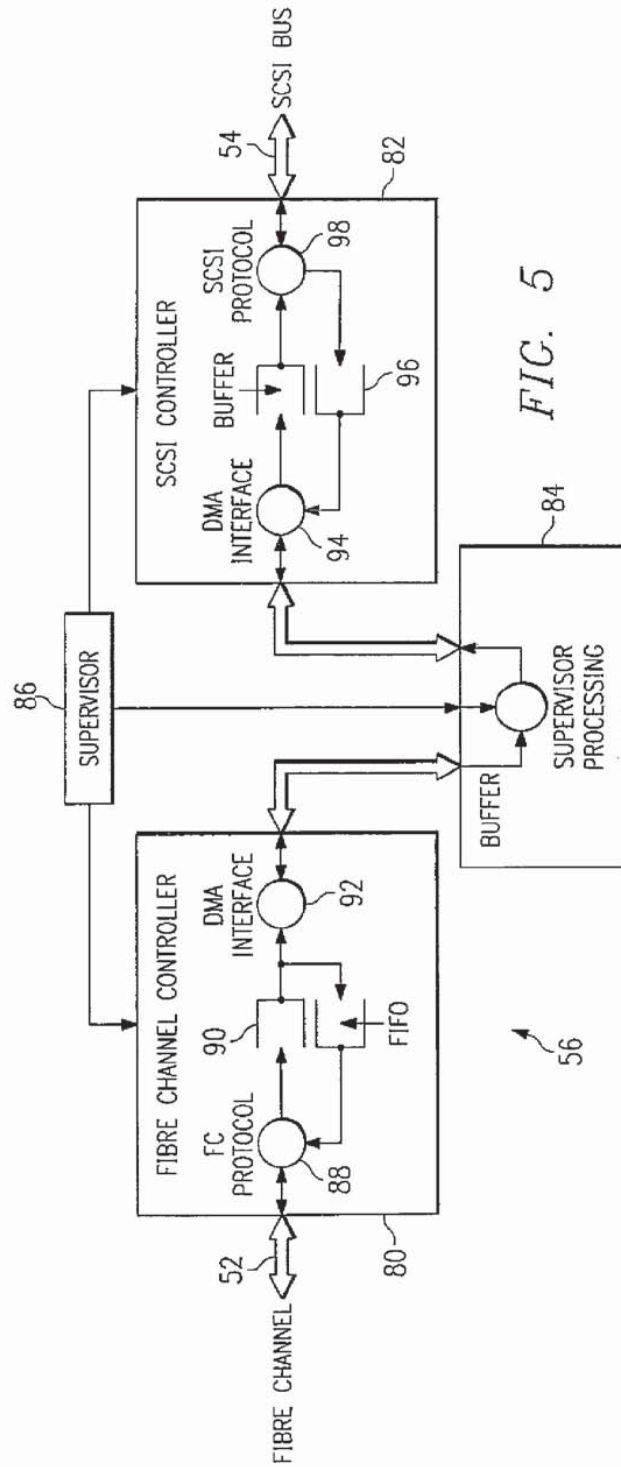
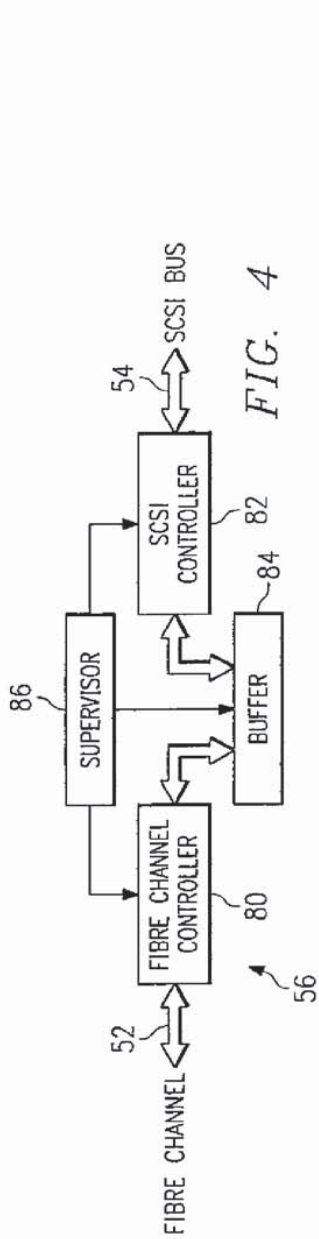



US 7,934,041 B2

1

**STORAGE ROUTER AND METHOD FOR PROVIDING VIRTUAL LOCAL STORAGE**

This application is a continuation of, and claims a benefit of priority under 35 U.S.C. 120 of the filing date of U.S. patent application Ser. No. 12/552,885 entitled "Storage Router and Method for Providing Virtual Local Storage" filed Sep. 2, 2009, which is a continuation of and claims the benefit of priority of U.S. application Ser. No. 11/851,724 entitled "Storage Router and Method for Providing Virtual Local Storage" filed Sep. 7, 2007, now U.S. Pat. No. 7,689,754 issued Mar. 30, 2010, which is a continuation of and claims the benefit of priority of U.S. patent application Ser. No. 11/442,878 entitled "Storage Router and Method for Providing Virtual Local Storage" filed May 30, 2006, now abandoned, which is a continuation of and claims the benefit of priority of U.S. patent application Ser. No. 11/353,826 entitled "Storage Router and Method for Providing Virtual Local Storage" filed on Feb. 14, 2006, now U.S. Pat. No. 7,340,549 issued Mar. 4, 2008, which is a continuation of and claims the benefit of priority of U.S. patent application Ser. No. 10/658,163 entitled "Storage Router and Method for Providing Virtual Local Storage" filed on Sep. 9, 2003 now U.S. Pat. No. 7,051,147 issued May 23, 2006, which is a continuation of and claims the benefit of priority of U.S. patent application Ser. No. 10/081,110 by inventors Geoffrey B. Hoese and Jeffery T. Russell, entitled "Storage Router and Method for Providing Virtual Local Storage" filed on Feb. 22, 2002, now U.S. Pat. No. 6,789,152 issued on Sep. 7, 2004, which in turn is a continuation of and claims benefit of priority of U.S. application Ser. No. 09/354,682 by inventors Geoffrey B. Hoese and Jeffery T. Russell, entitled "Storage Router and Method for Providing Virtual Local Storage" filed on Jul. 15, 1999, now U.S. Pat. No. 6,421,753 issued on Jul. 16, 2002, which in turn is a continuation of and claims benefit of priority of U.S. patent application Ser. No. 09/001,799, filed on Dec. 31, 1997, now U.S. Pat. No. 5,941,972 issued on Aug. 24, 1999, and hereby incorporates these applications and patents by reference in their entireties as if they had been fully set forth herein.

**TECHNICAL FIELD OF THE INVENTION**

This invention relates in general to network storage devices, and more particularly to a storage router and method for providing virtual local storage on remote SCSI storage devices to Fibre Channel devices.

**BACKGROUND OF THE INVENTION**

Typical storage transport mediums provide for a relatively small number of devices to be attached over relatively short distances. One such transport medium is a Small Computer System Interface (SCSI) protocol, the structure and operation of which is generally well known as is described, for example, in the SCSI-1, SCSI-2 and SCSI-3 specifications. High speed serial interconnects provide enhanced capability to attach a large number of high speed devices to a common storage transport medium over large distances. One such, serial interconnect is Fibre Channel, the structure and operation of which is described, for example, in Fibre Channel Physical and Signaling Interface (FC-PH), ANSI X3.230 Fibre Channel Arbitrated Loop (FC-AL), and ANSI X3.272 Fibre Channel Private Loop Direct Attach (FC-PLDA).

Conventional computing devices, such as computer workstations, generally access storage locally or through network interconnects. Local storage typically consists of a disk drive,

2

tape drive, CD-ROM drive or other storage device contained within, or locally connected to the workstation. The workstation provides a file system structure that includes security controls, with access to the local storage device through native low level block protocols. These protocols map directly to the mechanisms used by the storage device and consist of data requests without security controls. Network interconnects typically provide access for a large number of computing devices to data storage on a remote network server. The remote network server provides file system structure, access control, and other miscellaneous capabilities that include the network interface. Access to data through the network server is through network protocols that the server must translate into low level requests to the storage device. A workstation with access to the server storage must translate its file system protocols into network protocols that are used to communicate with the server. Consequently, from the perspective of a workstation, or other computing device, seeking to access such server data, the access is much slower than access to data on a local storage device.

**SUMMARY OF THE INVENTION**

In accordance with the present invention, a storage router and method for providing virtual local storage on remote SCSI storage devices to Fibre Channel devices are disclosed that provide advantages over conventional network storage devices and methods.

According to one aspect of the present invention, a storage router and storage network provide virtual local storage on remote SCSI storage devices to Fibre Channel devices. A plurality of Fibre Channel devices, such as workstations, are connected to a Fibre Channel transport medium, and a plurality of SCSI storage devices are connected to a SCSI bus transport medium. The storage router interfaces between the Fibre Channel transport medium and the SCSI bus transport medium. The storage router maps between the workstations and the SCSI storage devices and implements access controls for storage space on the SCSI storage devices. The storage router then allows access from the workstations to the SCSI storage devices using native low level, block protocol in accordance with the mapping and the access controls.

According to another aspect of the present invention, virtual local storage on remote SCSI storage devices is provided to Fibre Channel devices. A Fibre Channel transport medium and a SCSI bus transport medium are interfaced with. A configuration is maintained for SCSI storage devices connected to the SCSI bus transport medium. The configuration maps between Fibre Channel devices and the SCSI storage devices and implements access controls for storage space on the SCSI storage devices. Access is then allowed from Fibre Channel initiator devices to SCSI storage devices using native low level, block protocol in accordance with the configuration.

A technical advantage of the present invention is the ability to centralize local storage for networked workstations without any cost of speed or overhead. Each workstation accesses its virtual local storage as if it were locally connected. Further, the centralized storage devices can be located in a significantly remote position even in excess of ten kilometers as defined by Fibre Channel standards.

Another technical advantage of the present invention is the ability to centrally control and administer storage space for connected users without limiting the speed with which the users can access local data. In addition, global access to data, backups, virus scanning and redundancy can be more easily accomplished by centrally located storage devices.



US 7,934,041 B2

3

A further technical advantage of the present invention is providing support for SCSI storage devices as local storage for Fibre Channel hosts. In addition, the present invention helps to provide extended capabilities for Fibre Channel and for management of storage subsystems.

#### BRIEF DESCRIPTION OF THE DRAWINGS

A more complete understanding of the present invention and the advantages thereof may be acquired by referring to the following description taken in conjunction with the accompanying drawings, in which like reference numbers indicate like features, and wherein:

FIG. 1 is a block diagram of a conventional network that provides storage through a network server;

FIG. 2 is a block diagram of one embodiment of a storage network with a storage router that provides global access and routing;

FIG. 3 is a block diagram of one embodiment of a storage network with a storage router that provides virtual local storage;

FIG. 4 is a block diagram of one embodiment of the storage router of FIG. 3; and

FIG. 5 is a block diagram of one embodiment of data flow within the storage router of FIG. 4.

#### DETAILED DESCRIPTION OF THE INVENTION

FIG. 1 is a block diagram of a conventional network, indicated generally at 10, that provides access to storage through a network server. As shown, network 10 includes a plurality of workstations 12 interconnected with a network server 14 via a network transport medium 16. Each workstation 12 can generally comprise a processor, memory, input/output devices, storage devices and a network adapter as well as other common computer components. Network server 14 uses a SCSI bus 18 as a storage transport medium to interconnect with a plurality of storage devices 20 (tape drives, disk drives, etc.). In the embodiment of FIG. 1, network transport medium 16 is a network connection and storage devices 20 comprise hard disk drives, although there are numerous alternate transport mediums and storage devices.

In network 10, each workstation 12 has access to its local storage device as well as network access to data on storage devices 20. The access to a local storage device is typically through native low level, block protocols. On the other hand, access by a workstation 12 to storage devices 20 requires the participation of network server 14 which implements a file system and transfers data to workstations 12 only through high level file system protocols. Only network server 14 communicates with storage devices 20 via native low level, block protocols. Consequently, the network access by workstations 12 through network server 14 is slow with respect to their access to local storage. In network 10, it can also be a logistical problem to centrally manage and administer local data distributed across an organization, including accomplishing tasks such as backups, virus scanning and redundancy.

FIG. 2 is a block diagram of one embodiment of a storage network, indicated generally at 30, with a storage router that provides global access and routing. This environment is significantly different from that of FIG. 1 in that there is no network server involved. In FIG. 2, a Fibre Channel high speed serial transport 32 interconnects a plurality of workstations 36 and storage devices 38. A SCSI bus storage transport medium interconnects workstations 40 and storage devices 42. A storage router 44 then serves to interconnect these mediums and provide devices on either medium global, trans-

4

parent access to devices on the other medium. Storage router 44 routes requests from initiator devices on one medium to target devices on the other medium and routes data between the target and the initiator. Storage router 44 can allow initiators and targets to be on either side. In this manner, storage router 44 enhances the functionality of Fibre Channel 32, by providing access, for example, to legacy SCSI storage devices on SCSI bus 34. In the embodiment of FIG. 2, the operation of storage router 44 can be managed by a management station 46 connected to the storage router via a direct serial connection.

In storage network 30, any workstation 36 or workstation 40 can access any storage device 38 or storage device 42 through native low level, block protocols, and vice versa. This functionality is enabled by storage router 44 which routes requests and data as a generic transport between Fibre Channel 32 and SCSI bus 34. Storage router 44 uses tables to map devices from one medium to the other and distributes requests and data across Fibre Channel 32 and SCSI bus 34 without any security access controls. Although this extension of the high speed serial interconnect provided by Fibre Channel is beneficial, it is desirable to provide security controls in addition to extended access to storage devices through a native low level, block protocol.

FIG. 3 is a block diagram of one embodiment of a storage network, indicated generally at 50, with a storage router that provides virtual local storage. Similar to that of FIG. 2, storage network 50 includes a Fibre Channel high speed serial interconnect 52 and a SCSI bus 54 bridged by a storage router 56. Storage router 56 of FIG. 3 provides for a large number of workstations 58 to be interconnected on a common storage transport and to access common storage devices 60, 62 and 64 through native low level, block protocols.

According to the present invention, storage router 56 has enhanced functionality to implement security controls and routing such that each workstation 58 can have access to a specific subset of the overall data stored in storage devices 60, 62 and 64. This specific subset of data has the appearance and characteristics of local storage and is referred to herein as virtual local storage. Storage router 56 allows the configuration and modification of the storage allocated to each attached workstation 58 through the use of mapping tables or other mapping techniques.

As shown in FIG. 3, for example, storage device 60 can be configured to provide global data 65 which can be accessed by all workstations 58. Storage device 62 can be configured to provide partitioned subsets 66, 68, 70 and 72, where each partition is allocated to one of the workstations 58 (workstations A, B, C and D). These subsets 66, 68, 70 and 72 can only be accessed by the associated workstation 58 and appear to the associated workstation 58 as local storage accessed using native low level, block protocols. Similarly, storage device 64 can be allocated as storage for the remaining workstation 58 (workstation E).

Storage router 56 combines access control with routing such that each workstation 58 has controlled access to only the specified partition of storage device 62 which forms virtual local storage for the workstation 58. This access control allows security control for the specified data partitions. Storage router 56 allows this allocation of storage devices 60, 62 and 64 to be managed by a management station 76. Management station 76 can connect directly to storage router 56 via a direct connection or, alternately, can interface with storage router 56 through either Fibre Channel 52 or SCSI bus 54. In the latter case, management station 76 can be a workstation or other computing device with special rights such that storage



US 7,934,041 B2

5

router 56 allows access to mapping tables and shows storage devices 60, 62 and 64 as they exist physically rather than as they have been allocated.

The environment of FIG. 3 extends the concept of single workstation having locally connected storage devices to a storage network 50 in which workstations 58 are provided virtual local storage in a manner transparent to workstations 58. Storage router 56 provides centralized control of what each workstation 58 sees as its local drive, as well as what data it sees as global data accessible by other workstations 58. Consequently, the storage space considered by the workstation 58 to be its local storage is actually a partition (i.e., logical storage definition) of a physically remote storage device 60, 62 or 64 connected through storage router 56. This means that similar requests from workstations 58 for access to their local storage devices produce different accesses to the storage space on storage devices 60, 62 and 64. Further, no access from a workstation 58 is allowed to the virtual local storage of another workstation 58.

The collective storage provided by storage devices 60, 62 and 64 can have blocks allocated by programming means within storage router 56. To accomplish this function, storage router 56 can include routing tables and security controls that define storage allocation for each workstation 58. The advantages provided by implementing virtual local storage in centralized storage devices include the ability to do collective backups and other collective administrative functions more easily. This is accomplished without limiting the performance of workstations 58 because storage access involves native low level, block protocols and does not involve the overhead of high level protocols and file systems required by network servers.

FIG. 4 is a block diagram of one embodiment of storage router 56 of FIG. 3. Storage router 56 can comprise a Fibre Channel controller 80 that interfaces with Fibre Channel 52 and a SCSI controller 82 that interfaces with SCSI bus 54. A buffer 84 provides memory work space and is connected to both Fibre Channel controller 80 and to SCSI controller 82. A supervisor unit 86 is connected to Fibre Channel controller 80, SCSI controller 82 and buffer 84. Supervisor unit 86 comprises a microprocessor for controlling operation of storage router 56 and to handle mapping and security access for requests between Fibre Channel 52 and SCSI bus 54.

FIG. 5 is a block diagram of one embodiment of data flow within storage router 56 of FIG. 4. As shown, data from Fibre Channel 52 is processed by a Fibre Channel (FC) protocol unit 88 and placed in a FIFO queue 90. A direct memory access (DMA) interface 92 then takes data out of FIFO queue 90 and places it in buffer 84. Supervisor unit 86 processes the data in buffer 84 as represented by supervisor processing 93. This processing involves mapping between Fibre Channel 52 and SCSI bus 54 and applying access controls and routing functions. A DMA interface 94 then pulls data from buffer 84 and places it into a buffer 96. A SCSI protocol unit 98 pulls data from buffer 96 and communicates the data on SCSI bus 54. Data flow in the reverse direction, from SCSI bus 54 to Fibre Channel 52, is accomplished in a reverse manner.

The storage router of the present invention is a bridge device that connects a Fibre Channel link directly to a SCSI bus and enables the exchange of SCSI command set information between application clients on SCSI bus devices and the Fibre Channel links. Further, the storage router applies access controls such that virtual local storage can be established in remote SCSI storage devices for workstations on the Fibre Channel link. In one embodiment, the storage router provides a connection for Fibre Channel links running the SCSI Fibre

6

Channel Protocol (FCP) to legacy SCSI devices attached to a SCSI bus. The Fibre Channel topology is typically an Arbitrated Loop (FC\_AL).

In part, the storage router enables a migration path Fibre Channel based, serial SCSI networks by providing connectivity for legacy SCSI bus devices. The storage router can be attached to a Fibre Channel Arbitrated Loop and a SCSI bus to support a number of SCSI devices. Using configuration settings, the storage router can make the SCSI bus devices available on the Fibre Channel network as FCP logical units. Once the configuration is defined, operation of the storage router is transparent to application clients. In this manner, the storage router can form an integral part of the migration to new Fibre Channel based networks while providing a means to continue using legacy SCSI devices.

In one implementation (not shown), the storage router can be a rack mount or free standing device with an internal power supply. The storage router can have a Fibre Channel and SCSI port, and a standard, detachable power cord can be used, the FC connector can be a copper DB9 connector, and the SCSI connector can be a 68-pin type. Additional modular jacks can be provided for a serial port and an 802.3 10 BaseT port, i.e. twisted pair Ethernet, for management access. The SCSI port of the storage router can support SCSI direct and sequential access target devices and can support SCSI initiators, as well. The Fibre Channel port can interface to SCSI-3 FCP enabled devices and initiators.

To accomplish its functionality, one implementation of the storage router uses: a Fibre Channel interface based on the HEWLETT-PACKARD TACHYON HPFC-5000 controller and a GLM media interface; an Intel 80960RP processor, incorporating independent data and program memory spaces, and associated logic required to implement a stand alone processing system; and a serial port for debug and system configuration. Further, this implementation includes a SCSI interface supporting Fast-20 based on the SYMBIOS 53C8xx series SCSI controllers, and an operating system based upon the WIND RIVERS SYSTEMS VXWORKS or IXWORKS kernel, as determined by design. In addition, the storage router includes software as required to control basic functions of the various elements, and to provide appropriate translations between the FC and SCSI protocols.

The storage router has various modes of operation that are possible between FC and SCSI target and initiator combinations. These modes are: FC Initiator to SCSI Target; SCSI Initiator to FC Target; SCSI Initiator to SCSI Target; and FC Initiator to FC Target. The first two modes can be supported concurrently in a single storage router device and are discussed briefly below. The third mode can involve two storage router devices back to back and can serve primarily as a device to extend the physical distance beyond that possible via a direct SCSI connection. The last mode can be used to carry FC protocols encapsulated on other transmission technologies (e.g. ATM, SONET), or to act as a bridge between two FC loops (e.g. as a two port fabric).

The FC Initiator to SCSI Target mode provides for the basic configuration of a server using Fibre Channel to communicate with SCSI targets. This mode requires that a host system have an FC attached device and associated device drivers and software to generate SCSI-3 FCP requests. This system acts as an initiator using the storage router to communicate with SCSI target devices. The SCSI devices supported can include SCSI-2 compliant direct or sequential access (disk or tape) devices. The storage router serves to translate command and status information and transfer data between SCSI-3 FCP and SCSI-2, allowing the use of standard SCSI-2 devices in a Fibre Channel environment.



US 7,934,041 B2

7

The SCSI Initiator to FC Target mode provides for the configuration of a server using SCSI-2 to communicate with Fibre Channel targets. This mode requires that a host system has a SCSI-2 interface and driver software to control SCSI-2 target devices. The storage router will connect to the SCSI-2 bus and respond as a target to multiple target IDs. Configuration information is required to identify the target IDs to which the bridge will respond on the SCSI-2 bus. The storage router then translates the SCSI-2 requests to SCSI-3 FCP requests, allowing the use of FC devices with a SCSI host system. This will also allow features such as a tape device acting as an initiator on the SCSI bus to provide full support for this type of SCSI device.

In general, user configuration of the storage router will be needed to support various functional modes of operation. Configuration can be modified, for example, through a serial port or through an Ethernet port via SNMP (simple network management protocol) or the Telnet session. Specifically, SNMP manageability can be provided via a B02.3 Ethernet interface. This can provide for configuration changes as well as providing statistics and error information. Configuration can also be performed via TELNET or RS-232 interfaces with menu driven command interfaces. Configuration information can be stored in a segment of flash memory and can be retained across resets and power off cycles. Password protection can also be provided.

In the first two modes of operation, addressing information is needed to map from FC addressing to SCSI addressing and vice versa. This can be 'hard' configuration data, due to the need for address information to be maintained across initialization and partial reconfigurations of the Fibre Channel address space. In an arbitrated loop configuration, user configured addresses will be needed for AL\_PAs in order to insure that known addresses are provided between loop reconfigurations.

With respect to addressing, FCP and SCSI 2 systems employ different methods of addressing target devices. Additionally, the inclusion of a storage router means that a method of translating device IDs needs to be implemented. In addition, the storage router can respond to commands without passing the commands through to the opposite interface. This can be implemented to allow all generic FCP and SCSI commands to pass through the storage router to address attached devices, but allow for configuration and diagnostics to be performed directly on the storage router through the FC and SCSI interfaces.

Management commands are those intended to be processed by the storage router controller directly. This may include diagnostic, mode, and log commands as well as other vendor-specific commands. These commands can be received and processed by both the FOP and SCSI interfaces, but are not typically bridged to the opposite interface. These commands may also have side effects on the operation of the storage router, and cause other storage router operations to change or terminate.

A primary method of addressing management commands through the FCP and SCSI interfaces can be through peripheral device type addressing. For example, the storage router can respond to all operations addressed to logical unit (LUN) zero as a controller device. Commands that the storage router will support can include INQUIRY as well as vendor-specific management commands. These are to be generally consistent with SCC standard commands.

The SCSI bus is capable of establishing bus connections between targets. These targets may internally address logical units. Thus, the prioritized addressing scheme used by SCSI subsystems can be represented as follows: BUS:TARGET:

8

LOGICAL UNIT. The BUS identification is intrinsic in the configuration, as a SCSI initiator is attached to only one bus. Target addressing is handled by bus arbitration from information provided to the arbitrating device. Target addresses are assigned to SCSI devices directly through some means of configuration, such as a hardware jumper, switch setting, or device specific software configuration. As such, the SCSI protocol provides only logical unit addressing within the Identify message. Bus and target information is implied by the established connection.

Fibre Channel devices within a fabric are addressed by a unique port identifier. This identifier is assigned to a port during certain well-defined states of the FC protocol. Individual ports are allowed to arbitrate for a known, user defined address. If such an address is not provided, or if arbitration for a particular-user address fails, the port is assigned a unique address by the FC protocol. This address is generally not guaranteed to be unique between instances. Various scenarios exist where the AL-PA of a device will change, either after power cycle or loop reconfiguration.

The FC protocol also provides a logical unit address field within command structures to provide addressing to devices internal to a port. The FCP\_CMD payload specifies an eight byte LUN field. Subsequent identification of the exchange between devices is provided by the FQXID (Fully Qualified Exchange ID).

FC ports can be required to have specific addresses assigned. Although basic functionality is not dependent on this, changes in the loop configuration could result in disk targets changing identifiers with the potential risk of data corruption or loss. This configuration can be straightforward, and can consist of providing the device a loop-unique ID (AL\_PA) in the range of "01h" to "EFh." Storage routers could be shipped with a default value with the assumption that most configurations will be using single storage routers and no other devices requesting the present ID. This would provide a minimum amount of initial configuration to the system administrator. Alternately, storage routers could be defaulted to assume any address so that configurations requiring multiple storage routers on a loop would not require that the administrator assign a unique ID to the additional storage routers.

Address translation is needed where commands are issued in the cases FC Initiator to SCSI Target and SCSI Initiator to FC Target. Target responses are qualified by the FQXID and will retain the translation acquired at the beginning of the exchange. This prevents configuration changes occurring during the course of execution of a command from causing data or state information to be inadvertently misdirected. Configuration can be required in cases of SCSI Initiator to FC Target, as discovery may not effectively allow for FCP targets to consistently be found. This is due to an FC arbitrated loop supporting addressing of a larger number of devices than a SCSI bus and the possibility of FC devices changing their AL-PA due to device insertion or other loop initialization.

In the direct method, the translation to BUS:TARGET: LUN of the SCSI address information will be direct. That is, the values represented in the FCP LUN field will directly map to the values in effect on the SCSI bus. This provides a clean translation and does not require SCSI bus discovery. It also allows devices to be dynamically added to the SCSI bus without modifying the address map. It may not allow for complete discovery by FCP initiator devices, as gaps between device addresses may halt the discovery process. Legacy SCSI device drivers typically halt discovery on a target device at the first unoccupied LUN, and proceed to the next target.



US 7,934,041 B2

9

This would lead to some devices not being discovered. However, this allows for hot plugged devices and other changes to the loop addressing.

In the ordered method, ordered translation requires that the storage router perform discovery on reset, and collapses the addresses on the SCSI bus to sequential FSP LUN values. Thus, the FCP LUN values 0-N can represent N+1 SCSI devices, regardless of SCSI address values, in the order in which they are isolated during the SCSI discovery process. This would allow the FCP initiator discovery process to identify all mapped SCSI devices without further configuration. This has the limitation that hot-plugged devices will not be identified until the next reset cycle. In this case, the address map also be altered as well.

In addition to addressing, according to the present invention, the storage router provides configuration and access controls that cause certain requests from FC Initiators to be directed to assigned virtual local storage partitioned on SCSI storage devices. For example, the same request for LUN 0 (local storage) by two different FC Initiators can be directed to two separate subsets of storage. The storage router can use tables to map, for each initiator, what storage access is available and what partition is being addressed by a particular request. In this manner, the storage space provided by SCSI storage devices can be allocated to FC initiators to provide virtual local storage as well as to create any other desired configuration for secured access.

Although the present invention has been described in detail, it should be understood that various changes, substitutions, and alterations can be made hereto without departing from the spirit and scope of the invention as defined by the appended claims.

What is claimed is:

1. A storage router for providing virtual local storage on remote storage devices, comprising:

a first controller operable to interface with a first transport medium, wherein the first medium is a serial transport media; and

a processing device coupled to the first controller, wherein the processing device is configured to:

maintain a map to allocate storage space on the remote storage devices to devices connected to the first transport medium by associating representations of the devices connected to the first transport medium with representations of storage space on the remote storage devices, wherein each representation of a device connected to the first transport medium is associated with one or more representations of storage space on the remote storage devices;

control access from the devices connected to the first transport medium to the storage space on the remote storage devices in accordance with the map; and

allow access from devices connected to the first transport medium to the remote storage devices using native low level block protocol.

2. The storage router of claim 1, wherein the map associates a representation of storage space on the remote storage devices with multiple devices connected to the first transport medium.

3. The storage router of claim 1, wherein the storage space on the remote storage devices comprises storage space on multiple remote storage devices.

4. The storage router of claim 1, wherein the map associates a representation of a device connected to the first transport medium with a representation of an entire storage space of at least one remote storage device.

10

5. The storage router of claim 1, wherein the map resides at the storage router and is maintained at the storage router.

6. The storage router of claim 1, wherein the native low level block protocol is received at the storage router via the first transport medium and the processing device uses the received native low level block protocol to allow the devices connected to the first transport medium access to storage space specifically allocated to them in the map.

7. The storage router of claim 1, wherein the storage router is configured to receive commands according to a first low level block protocol from the device connected to the first transport medium and forward commands according to a second low level block protocol to the remote storage devices.

8. The storage router of claim 7, wherein the first low level block protocol is an FCP protocol and the second low level block protocol is a protocol other than FCP.

9. The storage router of claim 1, wherein the map comprises one or more tables.

10. The storage router of claim 1, wherein the virtual local storage is provided to the devices connected to the first transport medium in a manner that is transparent to the devices and wherein the storage space allocated to the devices connected to the first transport medium appears to the devices as local storage.

11. The storage router of claim 1, wherein the storage router provides centralized control of what the devices connected to the first transport medium see as local storage.

12. The storage router of claim 1, wherein the representations of storage space comprise logical unit numbers that represent a subset of storage on the remote storage devices.

13. The storage router of claim 12, wherein the storage router is operable to route requests to the same logical unit number from different devices connected to the first transport medium to different subsets of storage space on the remote storage devices.

14. The storage router of claim 1, wherein the representations of devices connected to the first transport medium are unique identifiers.

15. The storage router of claim 14, wherein the unique identifiers are world wide names.

16. The storage router of claim 1, wherein the storage router is configured to allow modification of the map in a manner transparent to and without involvement of the devices connected to the first transport medium.

17. The storage router of claim 1, wherein the processing device is a microprocessor.

18. The storage router of claim 1, wherein the processing device is a microprocessor and associated logic to implement a stand-alone processing system.

19. The storage router of claim 1, wherein the first transport medium is a fibre channel transport medium and further comprising a second transport medium connected to the remote storage devices that is a fibre channel transport medium.

20. A storage network comprising:

a set of devices connected a first transport medium, wherein the first transport medium;

a set of remote storage devices connected to a second transport medium;

a storage router connected to the serial transport medium;

a storage router connected to the first transport medium and second transport medium to provide virtual local storage on the remote storage devices, the storage router configured to:

maintain a map to allocate storage space on the remote storage devices to devices connected to the first transport medium by associating representations of the devices connected to the first transport medium with



US 7,934,041 B2

11

representations of storage space on the remote storage devices, wherein each representation of a device connected to the first transport medium is associated with one or more representations of storage space on the remote storage devices;

control access from the devices connected to the first transport medium to the storage space on the remote storage devices in accordance with the map; and allow access from devices connected to the first transport medium to the remote storage devices using native low level block protocol.

21. The storage network of claim 20, wherein the map associates a representation of storage space on the remote storage devices with multiple devices connected to the first transport medium.

22. The storage network of claim 20, wherein the storage space on the remote storage devices comprises storage space on multiple remote storage devices.

23. The storage network of claim 20, wherein the map associates a representation of a device connected to the first transport medium with a representation of an entire storage space of at least one remote storage device.

24. The storage network of claim 20, wherein the map resides at the storage router and is maintained at the storage router.

25. The storage network of claim 20, wherein the native low level block protocol is received at the storage router via the first transport medium and the storage router uses the received native low level block protocol to allow the devices connected to the first transport medium access to storage space specifically allocated to them in the map.

26. The storage router of claim 20, wherein the storage router is configured to receive commands according to a first low level block protocol from the device connected to the first transport medium and forward commands according to a second low level block protocol to the remote storage devices.

27. The storage network of claim 20, wherein the first low level block protocol is an FCP protocol and the second low level block protocol is a protocol other than FCP.

28. The storage network of claim 20, wherein the map comprises one or more tables.

29. The storage network of claim 20, wherein the virtual local storage is provided to the devices connected to the first transport medium in a manner that is transparent to the devices and wherein the storage space allocated to the devices connected to the first transport medium appears to the devices as local storage.

30. The storage network of claim 20, wherein the storage router provides centralized control of what the devices connected to the first transport medium see as local storage.

31. The storage network of claim 20, wherein the representations of storage space comprise logical unit numbers that represent a subset of storage on the remote storage devices.

32. The storage network of claim 31, wherein the storage router is operable to route requests to the same logical unit number from different devices connected to the first transport medium to different subsets of storage space on the remote storage devices.

33. The storage network of claim 20, wherein the representations of devices connected to the first transport medium are unique identifiers.

34. The storage network of claim 33, wherein the unique identifiers are world wide names.

35. The storage network of claim 20, wherein the storage router is configured to allow modification of the map in a

12

manner transparent to and without involvement of the devices connected to the first transport medium.

36. The storage network of claim 20, wherein the first transport medium is a fibre channel transport medium and the second transport medium is a fibre channel transport medium.

37. A method for providing virtual local storage on remote storage devices comprising:

connecting a storage router between a set of devices connected to a first transport medium and a set of remote storage devices, wherein the first transport medium is a serial transport medium;

maintaining a map at the storage router to allocate storage space on the remote storage devices to devices connected to the first transport medium by associating representations of the devices connected to the first transport medium with representations of storage space on the remote storage devices, wherein each representation of a device connected to the first transport medium is associated with one or more representations of storage space on the remote storage devices;

controlling access from the devices connected to the first transport medium to the storage space on the remote storage devices in accordance with the map; and allowing access from devices connected to the first transport medium to the remote storage devices using native low level block protocol.

38. The method of claim 37, wherein the map associates a representation of storage space on the remote storage devices with multiple devices connected to the first transport medium.

39. The method of claim 37, wherein the storage space on the remote storage devices comprises storage space on multiple remote storage devices.

40. The method of claim 37, wherein the map associates a representation of a device connected to the first transport medium with a representation of an entire storage space of at least one remote storage device.

41. The method of claim 37, wherein the map resides at the storage router and is maintained at the storage router.

42. The method of claim 37, further comprising: receiving the native low level block protocol at the storage router via the first transport medium;

using the received native low level block protocol at the storage router to allow the devices connected to the first transport medium access to storage space specifically allocated to them in the map.

43. The method of claim 37, further comprising receiving commands at the storage router according to a first low level block protocol from the device connected to the first transport medium and forwarding commands according to a second low level block protocol to the remote storage devices.

44. The method of claim 43, wherein the first low level block protocol is an FCP protocol and the second low level block protocol is a protocol other than FCP.

45. The method of claim 37, wherein the map comprises one or more tables.

46. The method of claim 37, wherein the virtual local storage is provided to the devices connected to the first transport medium in a manner that is transparent to the devices and wherein the storage space allocated to the devices connected to the first transport medium appears to the devices as local storage.

47. The method of claim 37, wherein the storage router provides centralized control of what the devices connected to the first transport medium see as local storage.

48. The method of claim 37, wherein the representations of storage space comprise logical unit numbers that represent a subset of storage on the remote storage devices.

US 7,934,041 B2

**13**

49. The method of claim 48, wherein the storage router is operable to route requests to the same logical unit number from different devices connected to the first transport medium to different subsets of storage space on the remote storage devices.

50. The method of claim 37, wherein the representations of devices connected to the first transport medium are unique identifiers.

51. The method of claim 50, wherein the unique identifiers are world wide names.

52. The method of claim 51, wherein the storage router is configured to allow modification of the map in a manner

**14**

transparent to and without involvement of the devices connected to the first transport medium.

53. The method of claim 1 wherein connecting the storage router between a set of devices connected to a first transport medium and a set of remote storage devices further comprises connecting the storage router between a first fibre channel transport medium and a second fibre channel transport medium.

\* \* \* \* \*

UNITED STATES PATENT AND TRADEMARK OFFICE  
**CERTIFICATE OF CORRECTION**

PATENT NO. : 7,934,041 B2  
APPLICATION NO. : 12/690592  
DATED : April 26, 2011  
INVENTOR(S) : Geoffrey B. Hoese et al.

Page 1 of 1

It is certified that error appears in the above-identified patent and that said Letters Patent is hereby corrected as shown below:

Claim 20: Col. 10 line 56 should read -

A set of devices connected --to-- a first transport medium, wherein the first transport medium --is a serial transport medium--;

Signed and Sealed this  
Thirteenth Day of September, 2011

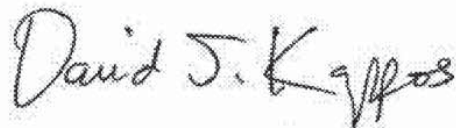

David J. Kappos  
*Director of the United States Patent and Trademark Office*



# **EXHIBIT C**

(12) **United States Patent**  
**Hoese et al.**

(10) **Patent No.:** US 7,051,147 B2  
 (45) **Date of Patent:** \*May 23, 2006

(54) **STORAGE ROUTER AND METHOD FOR PROVIDING VIRTUAL LOCAL STORAGE**

(75) Inventors: **Geoffrey B. Hoese**, Austin, TX (US);  
**Jeffrey T. Russell**, Cibolo, TX (US)

(73) Assignee: **Crossroads Systems, Inc.**, Austin, TX (US)

(\* ) Notice: Subject to any disclaimer, the term of this patent is extended or adjusted under 35 U.S.C. 154(b) by 0 days.

This patent is subject to a terminal disclaimer.

(21) Appl. No.: **10/658,163**

(22) Filed: **Sep. 9, 2003**

(65) **Prior Publication Data**

US 2004/0054838 A1 Mar. 18, 2004

**Related U.S. Application Data**

(63) Continuation of application No. 10/081,110, filed on Feb. 22, 2002, now Pat. No. 6,789,152, which is a continuation of application No. 09/354,682, filed on Jul. 15, 1999, now Pat. No. 6,421,753, which is a continuation of application No. 09/001,799, filed on Dec. 31, 1997, now Pat. No. 5,941,972.

(51) **Int. Cl.**  
**G06F 13/00** (2006.01)

(52) **U.S. Cl.** ..... 710/305; 710/11; 709/258

(58) **Field of Classification Search** ..... 710/1-5, 710/8-13, 22-28, 104-105, 305-306, 325, 710/250, 126-131, 36-38; 709/250, 258; 714/42; 711/112, 113, 110

See application file for complete search history.

(56) **References Cited**

U.S. PATENT DOCUMENTS

3,082,406 A 3/1963 Stevens  
 4,092,732 A 5/1978 Ouchi  
 4,415,970 A 11/1983 Swenson et al.  
 4,455,605 A 6/1984 Cormier et al.  
 4,504,927 A 3/1985 Callan

(Continued)

FOREIGN PATENT DOCUMENTS

EP 0810 530 A2 12/1997

(Continued)

OTHER PUBLICATIONS

DIGITAL StorageWorks, Using Your HSZ70 Array Controller in a SCSI Controller Shelf (DS-BA356-M Series), *User's Guide*, pp. 1-1 through A-5 with index, Jan. 1998.

(Continued)

*Primary Examiner*—Christopher Shin

(74) *Attorney, Agent, or Firm*—Sprinkle IP Law Group

(57) **ABSTRACT**

A storage router and storage network provide virtual local storage on remote storage devices to Fiber Channel devices. A plurality of Fiber Channel devices, such as workstations, are connected to a Fiber Channel transport medium, and a plurality of storage devices are connected to a second Fiber Channel transport medium. The storage router interfaces between the Fiber Channel transport media. The storage router maps between the workstations and the storage devices and implements access controls for storage space on the storage devices. The storage router then allows access from the workstations to the storage devices using native low level, block protocol in accordance with the mapping and the access controls.

**39 Claims, 2 Drawing Sheets**

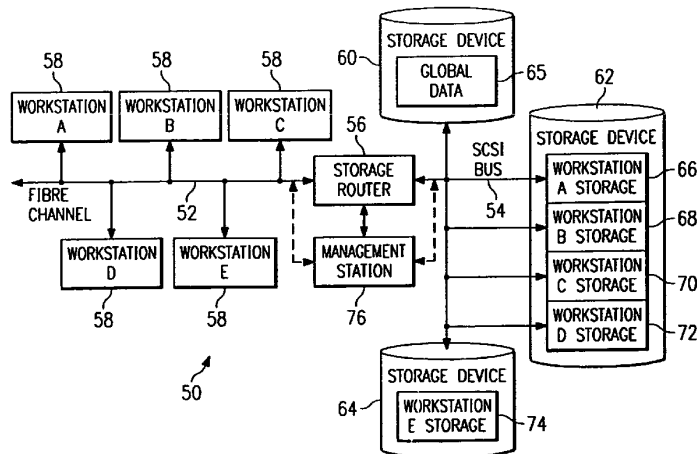

## US 7,051,147 B2

Page 2

| U.S. PATENT DOCUMENTS |   |         |                    |     |                                  |
|-----------------------|---|---------|--------------------|-----|----------------------------------|
|                       |   |         | 5,487,077          | A   | 1/1996 Hassner et al.            |
|                       |   |         | 5,491,812          | A   | 2/1996 Pisello et al.            |
|                       |   |         | 5,495,474          | A   | 2/1996 Olnowich et al.           |
|                       |   |         | 5,496,576          | A   | 3/1996 Jeong                     |
|                       |   |         | 5,504,857          | A   | 4/1996 Baird et al.              |
|                       |   |         | 5,507,032          | A   | 4/1996 Kimura                    |
|                       |   |         | 5,511,169          | A   | 4/1996 Suda                      |
|                       |   |         | 5,519,695          | A   | 5/1996 Purohit et al.            |
|                       |   |         | 5,530,845          | A   | 6/1996 Hiatt et al.              |
|                       |   |         | 5,535,352          | A   | 7/1996 Bridges et al.            |
|                       |   |         | 5,537,585          | A   | 7/1996 Blickerstaff et al.       |
|                       |   |         | 5,544,313          | A   | 8/1996 Shachnai et al.           |
|                       |   |         | 5,548,791          | A   | 8/1996 Casper et al.             |
|                       |   |         | 5,564,019          | A   | 10/1996 Beausoleil et al.        |
|                       |   |         | 5,568,648          | A   | 10/1996 Coscarella et al.        |
|                       |   |         | 5,581,709          | A   | 12/1996 Ito et al.               |
|                       |   |         | 5,581,714          | A   | 12/1996 Amini et al.             |
|                       |   |         | 5,581,724          | A   | 12/1996 Belsan et al.            |
|                       |   |         | 5,596,562          | A   | 1/1997 Chen                      |
|                       |   |         | 5,596,736          | A   | 1/1997 Kerns                     |
|                       |   |         | 5,598,541          | A   | 1/1997 Malladi                   |
|                       |   |         | 5,613,082          | A   | 3/1997 Brewer et al.             |
|                       |   |         | 5,621,902          | A   | 4/1997 Cases et al.              |
|                       |   |         | 5,632,012          | A   | 5/1997 Belsan et al.             |
|                       |   |         | 5,634,111          | A   | 5/1997 Oeda et al.               |
|                       |   |         | 5,638,518          | A   | 6/1997 Malladi                   |
|                       |   |         | 5,642,515          | A   | 6/1997 Jones et al.              |
|                       |   |         | 5,659,756          | A   | 8/1997 Hefferon et al.           |
|                       |   |         | 5,664,107          | A   | 9/1997 Chatwani et al.           |
|                       |   |         | 5,680,556          | A   | 10/1997 Begun et al.             |
|                       |   |         | 5,701,491          | A   | 12/1997 Dunn et al.              |
|                       |   |         | 5,712,976          | A   | 1/1998 Falcon, Jr. et al.        |
|                       |   |         | 5,727,218          | A   | 3/1998 Hotchkkin                 |
|                       |   |         | 5,729,705          | A   | 3/1998 Weber                     |
|                       |   |         | 5,743,847          | A   | 4/1998 Nakamura et al.           |
|                       |   |         | 5,748,924          | A   | 5/1998 Llorens et al.            |
|                       |   |         | 5,751,975          | A   | 5/1998 Gillespie et al.          |
|                       |   |         | 5,768,623          | A   | 6/1998 Judd et al.               |
|                       |   |         | 5,774,683          | A   | 6/1998 Gulick                    |
|                       |   |         | 5,781,715          | A   | 7/1998 Sheu                      |
|                       |   |         | 5,802,278          | A   | 9/1998 Isfeld et al.             |
|                       |   |         | 5,805,816          | A   | 9/1998 Picazo, Jr. et al.        |
|                       |   |         | 5,809,328          | A   | 9/1998 Nogales et al.            |
|                       |   |         | 5,812,754          | A   | 9/1998 Lui et al.                |
|                       |   |         | 5,835,496          | A   | 11/1998 Yeung et al.             |
|                       |   |         | 5,845,107          | A   | 12/1998 Fisch et al.             |
|                       |   |         | 5,848,251          | A   | 12/1998 Lomelino et al.          |
|                       |   |         | 5,857,080          | A   | 1/1999 Jander et al.             |
|                       |   |         | 5,860,137          | A   | 1/1999 Raz et al.                |
|                       |   |         | 5,864,653          | A   | 1/1999 Tavallaei et al.          |
|                       |   |         | 5,867,648          | A   | 2/1999 Foth et al.               |
|                       |   |         | 5,884,027          | A   | 3/1999 Garbus et al.             |
|                       |   |         | 5,889,952          | A   | 3/1999 Hunnicutt et al.          |
|                       |   |         | 5,913,045          | A   | 6/1999 Gillespie et al.          |
|                       |   |         | 5,923,557          | A   | 7/1999 Eidson                    |
|                       |   |         | 5,933,824          | A   | 8/1999 DeKoning et al.           |
|                       |   |         | 5,935,260          | A   | 8/1999 Ofer                      |
|                       |   |         | 5,941,969          | A   | 8/1999 Ram et al.                |
|                       |   |         | 5,941,972          | A * | 8/1999 Hoese et al. .... 710/315 |
|                       |   |         | 5,953,511          | A   | 9/1999 Sescilia et al.           |
|                       |   |         | 5,959,994          | A   | 9/1999 Boggs et al.              |
|                       |   |         | 5,974,530          | A   | 10/1999 Young                    |
|                       |   |         | 5,978,379          | A * | 11/1999 Chan et al. .... 370/403 |
|                       |   |         | 5,991,797          | A   | 11/1999 Futral et al.            |
|                       |   |         | 6,000,020          | A * | 12/1999 Chin et al. .... 711/162 |
|                       |   |         | 6,021,451          | A   | 2/2000 Bell et al.               |
|                       |   |         | 6,041,381          | A   | 3/2000 Hoese                     |
|                       |   |         | 6,055,603          | A   | 4/2000 Ofer et al.               |
|                       |   |         | 6,065,087          | A   | 5/2000 Keaveny et al.            |
|                       |   |         | 6,070,253          | A   | 5/2000 Tavallaei et al.          |
|                       |   |         | 6,073,209          | A   | 6/2000 Bergsten                  |
|                       |   |         | 6,073,218          | A   | 6/2000 DeKoning et al.           |
|                       |   |         | 6,075,863          | A   | 6/2000 Krishnan et al.           |
| 4,533,996             | A | 8/1985  | Gartung et al.     |     |                                  |
| 4,573,152             | A | 2/1986  | Greene et al.      |     |                                  |
| 4,603,380             | A | 7/1986  | Easton et al.      |     |                                  |
| 4,620,295             | A | 10/1986 | Aiden, Jr.         |     |                                  |
| 4,644,462             | A | 2/1987  | Matsubara et al.   |     |                                  |
| 4,695,948             | A | 9/1987  | Blevins et al.     |     |                                  |
| 4,697,232             | A | 9/1987  | Brunelle et al.    |     |                                  |
| 4,751,635             | A | 6/1988  | Kret               |     |                                  |
| 4,787,028             | A | 11/1988 | Finfork et al.     |     |                                  |
| 4,807,180             | A | 2/1989  | Takeuchi et al.    |     |                                  |
| 4,811,278             | A | 3/1989  | Bean et al.        |     |                                  |
| 4,821,179             | A | 4/1989  | Jensen et al.      |     |                                  |
| 4,825,406             | A | 4/1989  | Bean et al.        |     |                                  |
| 4,827,411             | A | 5/1989  | Arrowood et al.    |     |                                  |
| 4,835,674             | A | 5/1989  | Collins et al.     |     |                                  |
| 4,864,532             | A | 9/1989  | Reeve et al.       |     |                                  |
| 4,897,874             | A | 1/1990  | Lidensky et al.    |     |                                  |
| 4,947,367             | A | 8/1990  | Chang et al.       |     |                                  |
| 4,961,224             | A | 10/1990 | Yung               |     |                                  |
| 5,072,378             | A | 12/1991 | Manka              |     |                                  |
| 5,077,732             | A | 12/1991 | Fischer et al.     |     |                                  |
| 5,077,736             | A | 12/1991 | Dunphy, Jr. et al. |     |                                  |
| 5,124,987             | A | 6/1992  | Milligan et al.    |     |                                  |
| 5,155,845             | A | 10/1992 | Beal et al.        |     |                                  |
| 5,163,131             | A | 11/1992 | Row et al.         |     |                                  |
| 5,185,876             | A | 2/1993  | Nguyen et al.      |     |                                  |
| 5,193,168             | A | 3/1993  | Corrigan et al.    |     |                                  |
| 5,193,184             | A | 3/1993  | Belsan et al.      |     |                                  |
| 5,202,856             | A | 4/1993  | Glider et al.      |     |                                  |
| 5,210,866             | A | 5/1993  | Milligan et al.    |     |                                  |
| 5,212,785             | A | 5/1993  | Powers et al.      |     |                                  |
| 5,214,778             | A | 5/1993  | Glider et al.      |     |                                  |
| 5,226,143             | A | 7/1993  | Baird et al.       |     |                                  |
| 5,239,632             | A | 8/1993  | Larner             |     |                                  |
| 5,239,643             | A | 8/1993  | Blount et al.      |     |                                  |
| 5,239,654             | A | 8/1993  | Ing-Simmons        |     |                                  |
| 5,247,638             | A | 9/1993  | O'Brien et al.     |     |                                  |
| 5,247,692             | A | 9/1993  | Fujimura           |     |                                  |
| 5,257,386             | A | 10/1993 | Saito              |     |                                  |
| 5,297,262             | A | 3/1994  | Cox et al.         |     |                                  |
| 5,301,290             | A | 4/1994  | Tetzlaff et al.    |     |                                  |
| 5,315,657             | A | 5/1994  | Abadi et al.       |     |                                  |
| 5,317,739             | A | 5/1994  | Elko et al.        |     |                                  |
| 5,331,673             | A | 7/1994  | Elko et al.        |     |                                  |
| 5,347,384             | A | 9/1994  | McReynolds et al.  |     |                                  |
| 5,361,347             | A | 11/1994 | Glider et al.      |     |                                  |
| 5,367,646             | A | 11/1994 | Pardillos et al.   |     |                                  |
| 5,379,385             | A | 1/1995  | Shomler            |     |                                  |
| 5,379,398             | A | 1/1995  | Cohn et al.        |     |                                  |
| 5,388,243             | A | 2/1995  | Glider et al.      |     |                                  |
| 5,388,246             | A | 2/1995  | Kasai              |     |                                  |
| 5,394,526             | A | 2/1995  | Crouse et al.      |     |                                  |
| 5,396,596             | A | 3/1995  | Hashemi et al.     |     |                                  |
| 5,403,639             | A | 4/1995  | Belsan et al.      |     |                                  |
| 5,410,667             | A | 4/1995  | Belsan et al.      |     |                                  |
| 5,410,697             | A | 4/1995  | Baird et al.       |     |                                  |
| 5,414,820             | A | 5/1995  | McFarland et al.   |     |                                  |
| 5,416,915             | A | 5/1995  | Mattson et al.     |     |                                  |
| 5,418,909             | A | 5/1995  | Jachowski et al.   |     |                                  |
| 5,420,988             | A | 5/1995  | Elliott            |     |                                  |
| 5,423,026             | A | 6/1995  | Cook et al.        |     |                                  |
| 5,423,044             | A | 6/1995  | Sutton et al.      |     |                                  |
| 5,426,637             | A | 6/1995  | Derby et al.       |     |                                  |
| 5,430,855             | A | 7/1995  | Wash et al.        |     |                                  |
| 5,450,570             | A | 9/1995  | Richek et al.      |     |                                  |
| 5,452,421             | A | 9/1995  | Beardsley et al.   |     |                                  |
| 5,459,857             | A | 10/1995 | Ludlam et al.      |     |                                  |
| 5,463,754             | A | 10/1995 | Beausoleil et al.  |     |                                  |
| 5,465,382             | A | 11/1995 | Day, III et al.    |     |                                  |
| 5,469,576             | A | 11/1995 | Dauerer et al.     |     |                                  |
| 5,471,609             | A | 11/1995 | Yudenfriend        |     |                                  |



## US 7,051,147 B2

Page 3

|           |     |         |                   |         |
|-----------|-----|---------|-------------------|---------|
| 6,081,849 | A   | 6/2000  | Born et al.       |         |
| 6,098,149 | A   | 8/2000  | Ofer et al.       |         |
| 6,108,684 | A   | 8/2000  | DeKoning et al.   |         |
| 6,118,766 | A   | 9/2000  | Akers             |         |
| 6,131,119 | A   | 10/2000 | Fukui             |         |
| 6,134,617 | A   | 10/2000 | Weber             |         |
| 6,141,737 | A   | 10/2000 | Krantz et al.     |         |
| 6,145,006 | A   | 11/2000 | Vishlitsky et al. |         |
| 6,148,004 | A   | 11/2000 | Nelson et al.     |         |
| 6,185,203 | B1* | 2/2001  | Berman            | 370/351 |
| 6,209,023 | B1  | 3/2001  | Dimitroff et al.  |         |
| 6,219,771 | B1  | 4/2001  | Kikuchi et al.    |         |
| 6,223,266 | B1  | 4/2001  | Sartore           |         |
| 6,230,218 | B1  | 5/2001  | Casper et al.     |         |
| 6,260,120 | B1  | 7/2001  | Blumenau et al.   |         |
| 6,330,629 | B1  | 12/2001 | Kondo et al.      |         |
| 6,341,315 | B1  | 1/2002  | Arroyo et al.     |         |
| 6,343,324 | B1  | 1/2002  | Hubis et al.      |         |
| 6,363,462 | B1  | 3/2002  | Bergsten          |         |
| 6,421,753 | B1* | 7/2002  | Hoese et al.      | 710/305 |
| 6,425,035 | B1* | 7/2002  | Hoese et al.      | 710/105 |
| 6,425,036 | B1  | 7/2002  | Hoese et al.      |         |
| 6,484,245 | B1  | 11/2002 | Sanada et al.     |         |
| 6,529,996 | B1  | 3/2003  | Nguyen et al.     |         |
| 6,738,854 | B1* | 5/2004  | Hoese et al.      | 710/305 |
| 6,763,419 | B1* | 7/2004  | Hoese et al.      | 709/250 |
| 6,789,152 | B1* | 9/2004  | Hoese et al.      | 710/305 |

## FOREIGN PATENT DOCUMENTS

|    |             |    |         |
|----|-------------|----|---------|
| EP | 0827059     | A2 | 3/1998  |
| GB | 2296798     | A  | 7/1996  |
| GB | 2297636     | A  | 8/1996  |
| GB | 2341715     |    | 3/2000  |
| JP | 6301607     |    | 10/1994 |
| JP | 8-230895    |    | 9/1996  |
| WO | WO 98/36357 |    | 8/1998  |
| WO | WO 99/34297 | A1 | 7/1999  |

## OTHER PUBLICATIONS

DIGITAL StorageWorks, HSZ70 Array Controller HSOFF Version 7.0 (EK-HSZ70-CG.A01), *Configuration Manual*, pp. 1-2 through G15 with index, Jul. 1997.

DIGITAL StorageWorks, HSZ70 Array Controller HSOFF Version 7.0, *CLI Reference Manual*, pp. 1-156, Jul. 1997.

Decision Returning Petition mailed Feb. 28, 2005.

Block-Based Distributed File Systems, Anthony J. McGregor, Jul. 1997.

Compaq StorageWorks HSG80 Array Controller ACS Version 8.3 (Maintenance and Service Guide) Nov. 1998.

Compaq StorageWorks HSG80 Array Controller ACS Version 8.3 (Configuration and CLI Reference Guide) Nov. 1998.

CRD-5500 SCSI RAID Controller User's Manual CMD Technology, Inc. pp. 1-1 to 6-25, revised Nov. 21, 1996.

DIGITAL Storage Works, HSZ70 Array Controller, HSOFF Version 7.0 EK-HSZ70-CG. A01, Digital Equipment Corporation, Maynard, Massachusetts.

DIGITAL StorageWorks HSZ70 Array Controller HSOFF Version 7.0 EK-HSZ70-RM. A01 CLI Reference Manual.

DIGITAL StorageWorks HSZ70 Array Controller HSOFF Version 7.0 EK-HSZ70-SV. A01, 1997.

DIGITAL StorageWorks HSG80 Array Controller ACS Version 8.0 (User's Guide Jan. 1998).

DP5380 Asynchronous SCSI Interface, National Semiconductor Corporation, Arlington, TX, May 1989, pp. 1-32.

Emerson, "Ancor Communications: Performance evaluation of switched fibre channel I/O system using—FCP for SCSI" Feb. 1, 1995, IEEE, pp. 479-484.

Fibre Channel and ATM: The Physical Layers, Jerry Quam WESCON/94, published Sep. 27-29, 1994. pp. 648-652.

Fiber Channel storage interface for video-on-demand servers by Anzaloni, et al, Jun. 15, 1905.

Gen5 S-Series XL System Guide Revision 1.01 by Chen, Jun. 18, 1905.

Graphical User Interface for MAXSTRAT Gen5/Gen-S Servers User's guide 1.1, Jun. 11, 1996.

High Performance Data transfers Using Network-Attached Peripherals at the national Storage Laboratory by Hyer, Feb. 26, 1993.

IFT-3000 SCSI to SCSI Disk array Controller Instruction Manual Revision 2.0 by Infotrend Technologies, Inc., 1995.

Implementing a Fibre Channel SCSI transport by Snively, 1994.

"InfoServer 150—Installation and Owner's Guide", EK-INFVS-OM-001, Digital Equipment Corporation, Maynard, Massachusetts 1991, Chapters 1 and 2.

InfoServer 150VXT Photograph.

Infoserver 100 System Operations Guide, First Edition Digital Equipment Corporation, 1990.

Johnson, D.B., et al., "The Peregrine High Performance RPC System", *Software-Practice and Experience*, 23(2):201-221, Feb. 1993.

Local-Area networks for the IBM PC by Haugdahl.

Misc. Reference Manual Pages, SunOS 5.09.

New serial I/Os speed storage subsystems by Bursky, Feb. 6, 1995.

Petal: Distributed Virtual Disks, Edward K. Lee and Chandramohan A. Thekkath, ACM SIGPLAN Notices, vol. 31, Issue 9, Sep. 1996, pp. 84-92.

Pictures of internal components of the InfoServer 150, taken from <http://bindarydinosaurs.couk/Museum/Digital/infoserver/infoserver.php> in Nov. 2004.

Raidtec FibreArray and Raidtec FlexArray UltraRAID Systems, Windows IT PRO Article, Oct. 1997.

S.P. Joshi, "Ethernet controller chip interfaces with variety of 16-bit processors," *electronic Design*, Hayden Publishing Co., Inc., Rochelle Part, NJ, Oct. 14, 1982. pp. 193-200.

Simplest Migration to Fibre Channel Technology Article, Digital Equipment Corporation, Nov. 10, 1997, published on PR Newswire.

Systems Architectures Using Fibre Channel, Roger Cummings, Twelfth IEEE Symposium on Mass Storage Systems, Copyright 1993 IEEE. pp. 251-256.

Dot Hill's Request to Exceed Page Limit in Motion for Summary Judgment filed Jun. 29, 2005. Case No. A-03-CV-754 (SS).

Request for Ex Parte Reexamination for 6,425,035. Third Party Requester: William A. Blake.

Request for Ex Parte Reexamination for 6,425,035. Third Party Requester: Natu J. Patel.

Office Action dated Jan. 21, 2003 for 10/174,720 (CROSS1120-8).

Office Action dated Feb. 27, 2001 for 09/354,682 (CROSS1120-1).

Office Action dated Aug. 11, 2000 for 09/354,682 (CROSS1120-1).

Office Action dated Dec. 16, 1999 for 09/354,682 (CROSS1120-1).

Office Action dated Nov. 6, 2002 for 10/023,786 (CROSS1120-4).

Office Action dated Jan. 21, 2003 for 10/081,110 (CROSS1120-5).

## US 7,051,147 B2

Page 4

Office Action in Ex Parte Reexamination 90/007,127, mailed Feb. 7, 2005.

Reply to Office Action Under Ex Parte Reexamination Dated Feb. 2, 2007 for 90/007,127 filed on Apr. 6, 2005.

Reply to Office Action Under Ex Parte Reexamination Dated Feb. 2, 2007 for 90/007,125 and 90/007,317 filed on Apr. 6, 2005.

Office Action in Ex Parte Reexamination 90/007,126, mailed Feb. 7, 2005.

Reply to Office Action Under Ex Parte Reexamination Dated Feb. 2, 2007 for 90/007,126 filed on Apr. 6, 2005.

Office Action in Ex Parte Reexamination 90/007,124, mailed Feb. 7, 2005.

Office Action in Ex Parte Reexamination 90/007,123, mailed Feb. 7, 2005.

Reply to Office Action Under Ex Parte Reexamination Dated Feb. 2, 2007 for 90/007,123 filed on Apr. 5, 2005.

European Office Action issued Apr. 1, 2004 in Application No. 98966104.6-2413.

Fiber Channel (FCS)/ATM Interworking: A Design Solution by Anzaloni, et al.

Copies of the following are on the attached CD-Rom.

Defendant's First Supplemental Trial Exhibit List, Crossroads Systems, Inc., v. Chaparral Network Storage, Inc., C.A. No. A-00CA-217-SS (W.D. Tex. 2001). (CD-Rom).

Defendant's Third Supplemental Trial Exhibit List, Crossroads Systems, Inc. v. Pathlight Technology, Inc., C.A. No. A-00CA-248-SS (W.D. Tex. 2001) (CD-Rom).

Defendant Chaparral Network Storage, Inc.'s First Supplemental Trial Exhibit List (D1 through D271) (CD-ROM Chaparral Exhibits ExList\_Def), Sep. 2, 2001.

Plaintiff's Fourth Amended Trial Exhibit List, Crossroads Systems, Inc. v. Chaparral Network Storage, Inc., C.A. No. A-00CA-217-SS (W.D. Tex. 2001) (CD-Rom), Sep. 11, 2001.

Trail Transcripts, Crossroads Systems, Inc. v. Chaparral Network Storage, Inc., C.A. No. A-00CA-217-SS (W.D. Tex. 2001). (CD-Rom).

Trail Transcripts, Crossroads Systems, Inc. v. Pathlight Technology, Inc., C.A. No. A-00CA-248-SS (W.D. Tex. 2001). (CD-Rom).

Datasheet for CrossPoint 4100 Fibre Channel to SCSI Router (Dedek Ex 41 (ANCT 117-120)) (CD-ROM Chaparral Exhibits D012).

Symbios Logic- Software Interface Specification Series 3 SCSI RAID Controller Software Release 02.xx (Engelbrecht Ex 2 (LSI 1421-1658)) (CD-ROM Chaparral Exhibits D013), Dec. 3, 1997.

Press Release- Symbios Logic to Demonstrate Strong Support for Fibre Channel at Fall Comdex (Engelbrecht 12 (LSI 2785-86)) (CD-ROM Chaparral Exhibits D016), Nov. 13, 1996.

OEM Datasheet on the 3701 Controller (Engelbrecht 13 (LSI 01837-38)) (CD-ROM Chaparral Exhibits D017), Jun. 17, 1995.

Nondisclosure Agreement Between Adaptec and Crossroads Dated Oct. 17, 1996 (Quisenberry Ex 25 (CRDS 8196)) (CD-ROM Chaparral Exhibits D020).

Organizational Presentation on the External Storage Group (Lavan Ex 1 (CNS 182242-255)) (CD-ROM Chaparral Exhibits D021), Apr. 11, 1996.

Bridge. C, Bridge Between SCSI-2 and SCSI-3 FCP (Fibre Channel Protocol) (CD-ROM Chaparral Exhibits P214).

Bridge Phase II Architecture Presentation (Lavan Ex 2 (CNS 182287-295)) (CD-ROM Chaparral Exhibits D022), Apr. 12, 1996.

Attendees/Action Items from Apr. 12, 1996 Meeting at BTC (Lavan Ex 3 (CNS 182241)) (CD-ROM Chaparral Exhibits D023), Apr. 12, 1996.

Brooklyn Hardware Engineering Requirements Documents, Revision 1.4 (Lavan Ex 4 (CNS 178188-211)) (CD-ROM Chaparral Exhibits D024) by Pecone, May 26, 1996.

Brooklyn Single-Ended SCSI RAID Bridge Controller Hardware OEM Manual, Revision 2.1 (Lavan EX 5 (CNS 177169-191)) (CD-ROM Chaparral Exhibits D025), Mar. 21, 1996.

Coronado Hardware Engineering Requirements Document, Revision 0.0 (Lavan Ex 7 (CNS 176917-932)) (CD-ROM Chaparral Exhibits D027) by O'Dell, Sep. 30, 1996.

ESS/FPG Organization (Lavan Ex 8 (CNS 178639-652)) (CD-ROM Chaparral Exhibits D028), Dec. 6, 1996.

Adaptec MCS ESS Presents: Intelligent External I/O Raid Controllers "Bridge" Strategy (Lavan Ex 9 (CNS 178606-638)). (CD-ROM Chaparral Exhibits D029), Feb. 6, 1996.

AEC-7313 Fibre Channel Daughter Board (for Brooklyn) Engineering Specification, Revision 1.0 (Lavan Ex 10 (CNS 176830-850)) (CD-ROM Chaparral Exhibits D030), Feb. 27, 1997.

Bill of Material (Lavan Ex 14 (CNS 177211-214)) (CD-ROM Chaparral Exhibits D034), Jul. 24, 1997.

AEC-. 4412B, AEC-7412/B2 External RAID Controller Hardware OEM Manual, Revision 2.0 (Lavan Ex 15 (CNS 177082-123)) (CD-ROM Chaparral Exhibits D035), Jun. 27, 1997.

Coronado II, AEC-7312A Fibre Channel Daughter (for Brooklyn) Hardware Specification, Revision 1.2 (Lavan Ex 16 (CNS 177192-210)) (CD-ROM Chaparral Exhibits D036) by Tom Yang, Jul. 18, 1997.

AEC-4412B, AEC7412/3B External RAID Controller Hardware OEM Manual, Revision 3.0. (Lavan Ex 17 (CNS 177124-165)) (CD-ROM Chaparral Exhibits D037), Aug. 25, 1997.

Memo Dated Aug. 15, 1997 to AEC-7312A Evaluation Unit Customers re: B001 Release Notes (Lavan Ex 18 (CNS 182878-879)) (CD-ROM Chaparral Exhibits D038).

Brooklyn Main Board (AES-0302) MES Schedule (Lavan Ex 19 (CNS 177759-763)) (CD-ROM Chaparral Exhibits D039), Feb. 11, 1997.

News Release-Adaptec Adds Fibre Channel Option to its External RAID Controller Family (Lavan Ex 20 (CNS 182932-934)) (CD-ROM Chaparral Exhibits D040), May 6, 1997.

AEC-4412B/7412B User's Guide, Rev. A (Lavan Ex 21) (CD-ROM Chaparral Exhibits D041), Jun. 19, 1995.

Data Book- AIC-7895 PCI Bus Master Single Chip SCSI Host Adapter (Davies Ex 1 (CNS 182944-64)) (CD-ROM Chaparral Exhibits D046), May 21, 1996.

Data Book- AIC-1160 Fibre Channel Host Adapter ASIC (Davies Ex 2 (CNS 181800-825)) (CD-ROM Chaparral Exhibits D047), Jun. 18, 1995.

Viking RAID Software (Davies Ex 3 (CNS 180969-181026)) (CD-ROM Chaparral Exhibits D048), Jun. 18, 1995.

Header File with Structure Definitions (Davies Ex 4 (CNS 180009-018)) (CD-ROM Chaparral Exhibits D049), Aug. 8, 1996.

## US 7,051,147 B2

Page 5

C++ SourceCode for the SCSI Command Handler (Davies Ex 5 (CNS 179136-168)) (CD-ROM Chaparral Exhibits D050), Aug. 8, 1996.

Header File Data Structure (Davies Ex 6 (CNS 17997-180008)) (CD-ROM Chaparral Exhibits D051), Jan. 2, 1997.

SCSI Command Handler (Davies Ex 7 (CNS 179676-719)) (CD-ROM Chaparral Exhibits D052), Jan. 2, 1997.

Coronado: Fibre Channel to SCSI Intelligent RAID Controller Product Brief (Kalwitz Ex 1 (CNS 182804-805)) (CD-ROM Chaparral Exhibits D053).

Bill of Material (Kalwitz Ex 2 (CNS 181632-633)) (CD-ROM Chaparral Exhibits D054), Mar. 17, 1997.

Emails Dated Jan. 13-Mar. 31, 1997 from P. Collins to Moore: Status Reports (Kalwitz Ex 3 (CNS 182501-511)) (CD-ROM Chaparral Exhibits D055).

Hardware Schematics for the Fibre Channel Daughtercard Coronado (Kalwitz Ex 4 (CNS 181639-648)) (CD-ROM Chaparral Exhibits D056).

Adaptec Schematics re AAC-340 (Kalwitz Ex 14 (CNS 177215-251)) (CD-ROM Chaparral Exhibits D057).

Bridge Product Line Review (Manzanares Ex 3 (CNS 177307-336)) (CD-ROM Chaparral Exhibits D058).

AEC Bridge Series Products-Adaptec External Controller RAID Products Pre-Release Draft, v.6 (Manzanares Ex 4 (CNS 174632-653)). (CD-ROM Chaparral Exhibits D059), Oct. 28, 1997.

Hewlett-Packard Roseville Site Property Pass for Brian Smith (Dunning Ex 14 (HP 489) (CD-ROM Chaparral Exhibits D078), Nov. 7, 1996.

Distribution Agreement Between Hewlett-Packard and Crossroads (Dunning Ex 15 (HP 326-33) (CD-ROM Chaparral Exhibits D079).

HPFC-5000 Tachyon User's Manuel, First Edition (PTI 172419-839) (CD-ROM Chaparral Exhibits D084), May 1, 1996.

X3T10 994D—(Draft) Information Technology: SCSI-3 Architecture Model, Rev. 1.8 (PTI 165977) (CD-ROM Chaparral Exhibits D087).

X3T10 Project 1047D: Information Technology- SCSI-3 Controller Commands (SCC), Rev. 6c (PTI 166400-546) (CD-ROM Chaparral Exhibits D088), Sep. 3, 1996.

X3T10 995D- (Draft) SCSI-3 Primary Commands, Rev. 11 (Wanamaker Ex 5 (PTI 166050-229)) (CD-ROM Chaparral Exhibits D089), Nov. 13, 1996.

VBAR Volume Backup and Restore (CRDS 12200-202) (CD-ROM Chaparral Exhibits D099).

Preliminary Product Literature for Infinity Commstor's Fibre Channel to SCSI Protocol Bridge (Smith Ex 11; Quisenberry Ex 31 (SPLO 428-30) (CD-ROM Chaparral Exhibits D143), Aug. 19, 1996.

Letter dated Jul. 12, 1996 from J. Boykin to B. Smith re: Purchase Order for Evaluation Units from Crossroads (Smith Ex 24) CRDS 8556-57) (CD-ROM Chaparral Exhibits D144), Jul. 12, 1996.

CrossPoint 4100 Fibre Channel to SCSI Router Preliminary Datasheet (Hulsey Ex 9 (CRDS 16129-130)) (CD-ROM Chaparral Exhibits D145), Nov. 1, 1996.

CrossPoint 4400 Fibre Channel to SCSI Router Preliminary Datasheet (Bardach Ex. 9 Quisenberry Ex 33 (CRDS 25606-607)) (CD-ROM Chaparral Exhibits D153), Nov. 1, 1996.

Fax Dated Jul. 22, 1996 from L. Petti to B. Smith re: Purchase Order from Data General for FC2S Fibre to Channel SCSI Protocol Bridge Model 11 (Smith Ex 25; Quisenberry Ex 23; Bardach Ex 11 (CRDS 8552-55;8558) (CD-ROM Chaparral Exhibits D155).

Email Dated Dec. 20, 1996 from J. Boykin to B. Smith re: Purchase Order for Betas in Feb. and Mar. (Hoese Ex 16, Quisenberry Ex 25; Bardach Ex 12 (CRDS 13644-650) (CD-ROM Chaparral Exhibits D156).

Infinity Commstor Fibre Channel Demo for Fall Comdex, 1996 (Hoese Ex 15, Bardach Ex 13 (CRDS 27415) (CD-ROM Chaparral Exhibits D157).

Fax Dated Dec. 19, 1996 from B. Bardach to T. Rarich re: Purchase Order Information (Bardach Ex. 14; Smith Ex 16 (CRDS 4460)) (CD-ROM Chaparral Exhibits D158).

Miscellaneous Documents Regarding Comdex (Quisenberry Ex 2 (CRDS 27415-465)) (CD-ROM Chaparral Exhibits D165).

CrossPoint 4100 Fibre Channel to SCSI Router Preliminary Datasheet (Quisenberry) Ex 3 (CRDS 4933-34) (CD-ROM Chaparral Exhibits D166) (CD-ROM Chaparral Exhibits D166).

CrossPoint 4400 Fibre to Channel to SCSI Router Preliminary Datasheet; Crossroads Company and Product Overview (Quisenberry Ex 4 (CRDS 25606; 16136)) (CD-ROM Chaparral Exhibits D167).

Crossroads Purchase Order Log (Quisenberry Ex 9 (CRDS 14061-062)) (CD-ROM Chaparral Exhibits D172).

RAID Manager 5 with RDAC 5 for UNIX V.4 User's Guide (LSI-01854) (CD-ROM Chaparral Exhibits P062), Sep. 1, 1996.

Letter dated May 12, 1997 from Alan G. Leal to Barbara Bardach enclosing the original OEM License and Purchase Agreement between Hewlett-Packard Company and Crossroads Systems, Inc. (CRDS 02057) (CD-ROM Chaparral Exhibits P130).

CR4x00 Product Specification (CRDS 43929) (CD-ROM Chaparral Exhibits P267), Jun. 1, 1998.

Symbios Logic—Hardware Function Specification for the Symbios Logic Series 3 Fibre Channel Disk Array Controller Model 3701 (Engelbrecht Ex 3 (LSI-1659-1733) (CD-ROM Pathlight Exhibits D074).

Report of the Working Group on Storage I/O for Large Scale Computing; Department of Computer Science Duke University: CS-1996-21 (PTI 173330-347). (CD-ROM Pathlight Exhibits D098).

Brian Allison's 1999 Third Quarter Sales Plan (PDX 38 ) CNS 022120-132)) (CD-ROM Pathlight Exhibits D201), Jun. 5, 2001.

Brooklyn SCSI-SCSI Intellegent External RAID Bridge Definition Phase External Documentation (CD-ROM Pathlight Exhibits D129).

\* cited by examiner



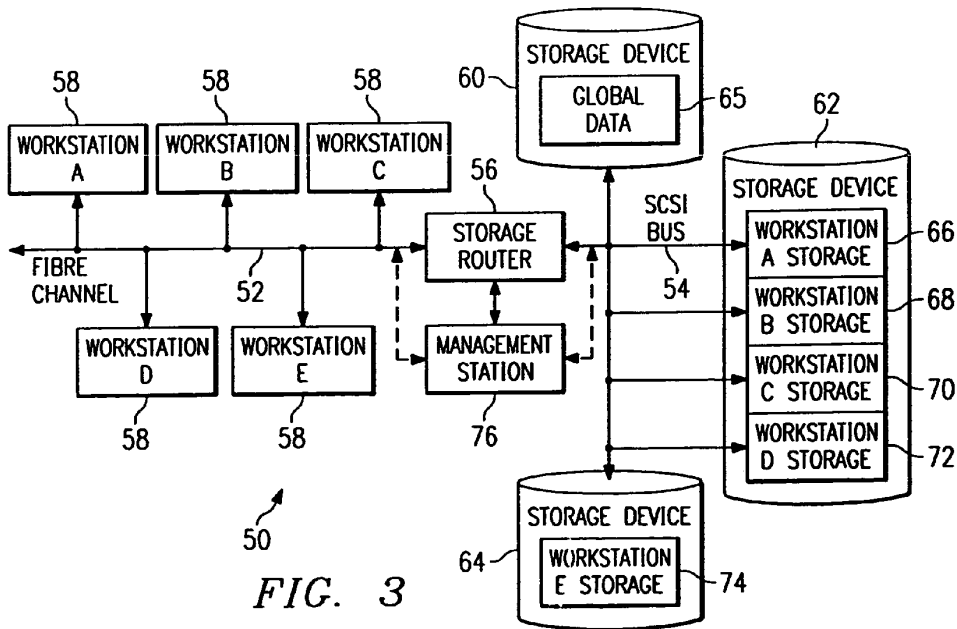
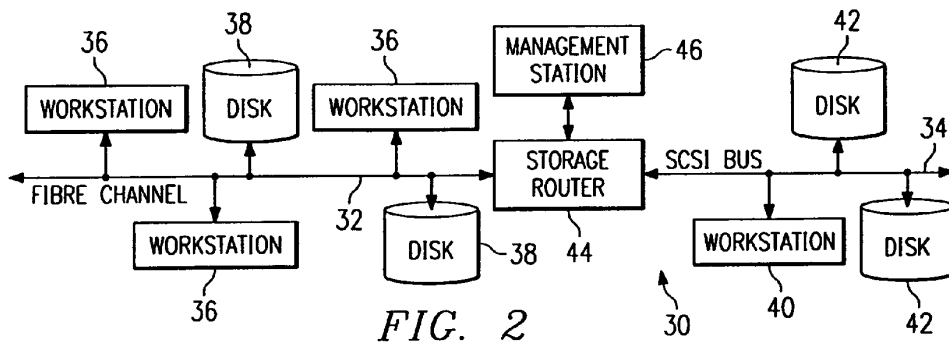
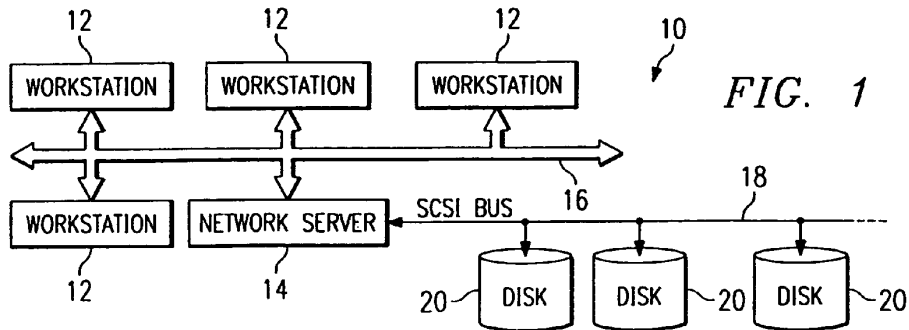

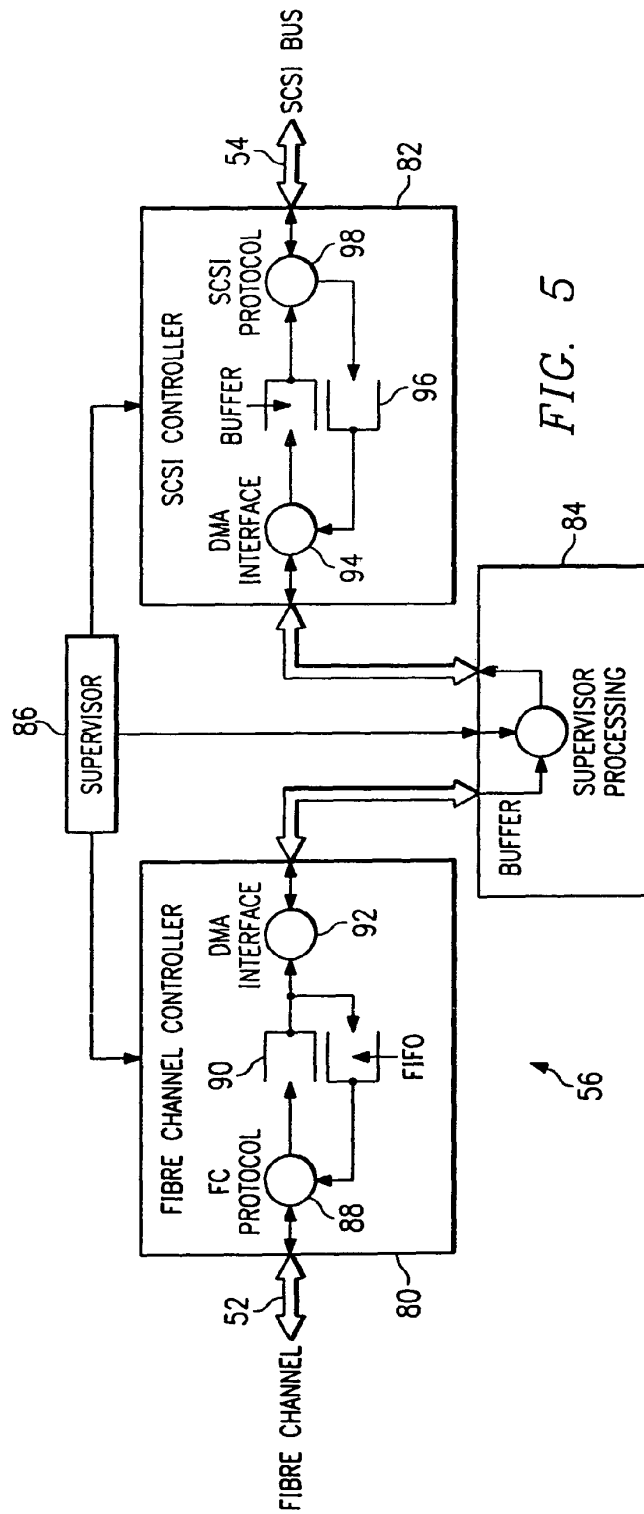
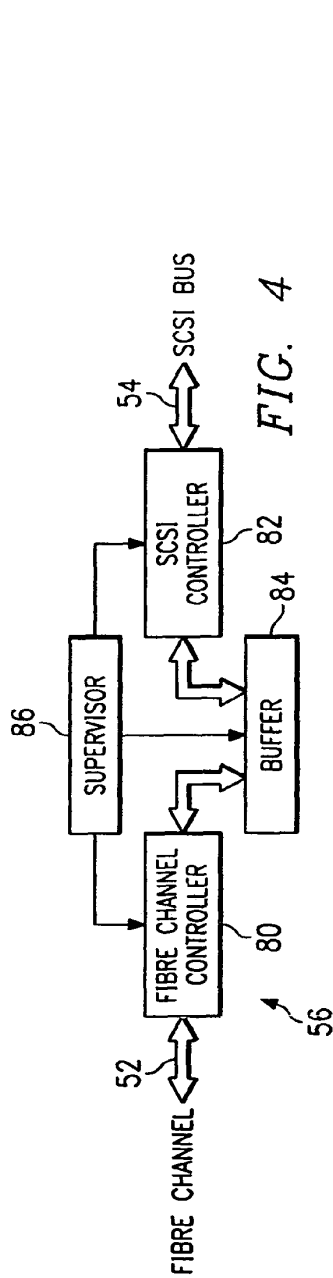

US 7,051,147 B2

1

**STORAGE ROUTER AND METHOD FOR PROVIDING VIRTUAL LOCAL STORAGE**

## RELATED APPLICATIONS

This application is a continuation of and claims the benefit of the filing dates of U.S. patent application Ser. No. 10/081,110 by inventors Geoffrey B. Hoese and Jeffrey T. Russell, entitled "Storage Router and Method for Providing Virtual Local Storage" filed on Feb. 22, 2002, now U.S. Pat. No. 6,789,152 which in turn is a continuation of U.S. application Ser. No. 09/354,682 by inventors Geoffrey B. Hoese and Jeffrey T. Russell, entitled "Storage Router and Method for Providing Virtual Local Storage" filed on Jul. 15, 1999, now U.S. Pat. No. 6,421,753, which in turn is a continuation of U.S. patent application Ser. No. 09/001,799, filed on Dec. 31, 1997, now U.S. Pat. No. 5,941,972, and hereby incorporates these applications by reference in their entireties as if they had been fully set forth herein.

## TECHNICAL FIELD OF THE INVENTION

This invention relates in general to network storage devices, and more particularly to a storage router and method for providing virtual local storage on remote SCSI storage devices to Fibre Channel devices.

## BACKGROUND OF THE INVENTION

Typical storage transport mediums provide for a relatively small number of devices to be attached over relatively short distances. One such transport medium is a Small Computer System Interface (SCSI) protocol, the structure and operation of which is generally well known as is described, for example, in the SCSI-1, SCSI-2 and SCSI-3 specifications. High speed serial interconnects provide enhanced capability to attach a large number of high speed devices to a common storage transport medium over large distances. One such serial interconnect is Fibre Channel, the structure and operation of which is described, for example, in *Fibre Channel Physical and signaling Interface (FC-PH)*, ANSI X3.230 *Fibre Channel Arbitrated Loop (FC-AL)*, and ANSI X3.272 *Fibre Channel Private Loop Direct Attach (FC-PLDA)*.

Conventional computing devices, such as computer workstations, generally access storage locally or through network interconnects. Local storage typically consists of a disk drive, tape drive, CD-ROM drive or other storage device contained within, or locally connected to the workstation. The workstation provides a file system structure, that includes security controls, with access to the local storage device through native low level, block protocols. These protocols map directly to the mechanisms used by the storage device and consist of data requests without security controls. Network interconnects typically provide access for a large number of computing devices to data storage on a remote network server. The remote network server provides file system structure, access control, and other miscellaneous capabilities that include the network interface. Access to data through the network server is through network protocols that the server must translate into low level requests to the storage device. A workstation with access to the server storage must translate its file system protocols into network protocols that are used to communicate with the server. Consequently, from the perspective of a workstation, or other computing device, seeking to access such server data, the access is much slower than access to data on a local storage device.

2

## SUMMARY OF THE INVENTION

In accordance with the present invention, a storage router and method for providing virtual local storage on remote SCSI storage devices to Fibre Channel devices are disclosed that provide advantages over conventional network storage devices and methods.

According to one aspect of the present invention, a storage router and storage network provide virtual local storage on remote SCSI storage devices to Fibre Channel devices. A plurality of Fibre Channel devices, such as workstations, are connected to a Fibre Channel transport medium, and a plurality of SCSI storage devices are connected to a SCSI bus transport medium. The storage router interfaces between the Fibre Channel transport medium and the SCSI bus transport medium. The storage router maps between the workstations and the SCSI storage devices and implements access controls for storage space on the SCSI storage devices. The storage router then allows access from the workstations to the SCSI storage devices using native low level, block protocol in accordance with the mapping and the access controls.

According to another aspect of the present invention, virtual local storage on remote SCSI storage devices is provided to Fibre Channel devices. A Fibre Channel transport medium and a SCSI bus transport medium are interfaced with. A configuration is maintained for SCSI storage devices connected to the SCSI bus transport medium. The configuration maps between Fibre Channel devices and the SCSI storage devices and implements access controls for storage space on the SCSI storage devices. Access is then allowed from Fibre Channel initiator devices to SCSI storage devices using native low level, block protocol in accordance with the configuration.

A technical advantage of the present invention is the ability to centralize local storage for networked workstations without any cost of speed or overhead. Each workstation access its virtual local storage as if it work locally connected. Further, the centralized storage devices can be located in a significantly remote position even in excess of ten kilometers as defined by Fibre Channel standards.

Another technical advantage of the present invention is the ability to centrally control and administer storage space for connected users without limiting the speed with which the users can access local data. In addition, global access to data, backups, virus scanning and redundancy can be more easily accomplished by centrally located storage devices.

A further technical advantage of the present invention is providing support for SCSI storage devices as local storage for Fibre Channel hosts. In addition, the present invention helps to provide extended capabilities for Fibre Channel and for management of storage subsystems.

## BRIEF DESCRIPTION OF THE DRAWINGS

A more complete understanding of the present invention and the advantages thereof may be acquired by referring to the following description taken in conjunction with the accompanying drawings, in which like reference numbers indicate like features, and wherein:

FIG. 1 is a block diagram of a conventional network that provides storage through a network server;

FIG. 2 is a block diagram of one embodiment of a storage network with a storage router that provides global access and routing;



US 7,051,147 B2

3

FIG. 3 is a block diagram of one embodiment of a storage network with a storage router that provides virtual local storage;

FIG. 4 is a block diagram of one embodiment of the storage router of FIG. 3; and

FIG. 5 is a block diagram of one embodiment of data flow within the storage router of FIG. 4.

#### DETAILED DESCRIPTION OF THE INVENTION

FIG. 1 is a block diagram of a conventional network, indicated generally at 10, that provides access to storage through a network server. As shown, network 10 includes a plurality of workstations 12 interconnected with a network server 14 via a network transport medium 16. Each workstation 12 can generally comprise a processor, memory, input/output devices, storage devices and a network adapter as well as other common computer components. Network server 14 uses a SCSI bus 18 as a storage transport medium to interconnect with a plurality of storage devices 20 (tape drives, disk drives, etc.). In the embodiment of FIG. 1, network transport medium 16 is a network connection and storage devices 20 comprise hard disk drives, although there are numerous alternate transport mediums and storage devices.

In network 10, each workstation 12 has access to its local storage device as well as network access to data on storage devices 20. The access to a local storage device is typically through native low level, block protocols. On the other hand, access by a workstation 12 to storage devices 20 requires the participation of network server 14 which implements a file system and transfers data to workstations 12 only through high level file system protocols. Only network server 14 communicates with storage devices 20 via native low level, block protocols. Consequently, the network access by workstations 12 through network server 14 is slow with respect to their access to local storage. In network 10, it can also be a logistical problem to centrally manage and administer local data distributed across an organization, including accomplishing tasks such as backups, virus scanning and redundancy.

FIG. 2 is a block diagram of one embodiment of a storage network, indicated generally at 30, with a storage router that provides global access and routing. This environment is significantly different from that of FIG. 1 in that there is no network server involved. In FIG. 2, a Fibre Channel high speed serial transport 32 interconnects a plurality of workstations 36 and storage devices 38. A SCSI bus storage transport medium interconnects workstations 40 and storage devices 42. A storage router 44 then serves to interconnect these mediums and provide devices on either medium global, transparent access to devices on the other medium. Storage router 44 routes requests from initiator devices on one medium to target devices on the other medium and routes data between the target and the initiator. Storage router 44 can allow initiators and targets to be on either side. In this manner, storage router 44 enhances the functionality of Fibre Channel 32 by providing access, for example, to legacy SCSI storage devices on SCSI bus 34. In the embodiment of FIG. 2, the operation of storage router 44 can be managed by a management station 46 connected to the storage router via a direct serial connection.

In storage network 30, any workstation 36 or workstation 40 can access any storage device 38 or storage device 42 through native low level, block protocols, and vice versa. This functionality is enabled by storage router 44 which

4

routes requests and data as a generic transport between Fibre Channel 32 and SCSI bus 34. Storage router 44 uses tables to map devices from one medium to the other and distributes requests and data across Fibre Channel 32 and SCSI bus 34 without any security access controls. Although this extension of the high speed serial interconnect provided by Fibre Channel 32 is beneficial, it is desirable to provide security controls in addition to extended access to storage devices through a native low level, block protocol.

FIG. 3 is a block diagram of one embodiment of a storage network, indicated generally at 50, with a storage router that provides virtual local storage. Similar to that of FIG. 2, storage network 50 includes a Fibre Channel high speed serial interconnect 52 and a SCSI bus 54 bridged by a storage router 56. Storage router 56 of FIG. 3 provides for a large number of workstations 58 to be interconnected on a common storage transport and to access common storage devices 60, 62 and 64 through native low level, block protocols.

According to the present invention, storage router 56 has enhanced functionality to implement security controls and routing such that each workstation 58 can have access to a specific subset of the overall data stored in storage devices 60, 62 and 64. This specific subset of data has the appearance and characteristics of local storage and is referred to herein as virtual local storage. Storage router 56 allows the configuration and modification of the storage allocated to each attached workstation 58 through the use of mapping tables or other mapping techniques.

As shown in FIG. 3, for example, storage device 60 can be configured to provide global data 65 which can be accessed by all workstations 58. Storage device 62 can be configured to provide partitioned subsets 66, 68, 70 and 72, where each partition is allocated to one of the workstations 58 (workstations A, B, C and D). These subsets 66, 68, 70 and 72 can only be accessed by the associated workstation 58 and appear to the associated workstation 58 as local storage accessed using native low level, block protocols. Similarly, storage device 64 can be allocated as storage for the remaining workstation 58 (workstation E).

Storage router 56 combines access control with routing such that each workstation 58 has controlled access to only the specified partition of storage device 62 which forms virtual local storage for the workstation 58. This access control allows security control for the specified data partitions. Storage router 56 allows this allocation of storage devices 60, 62 and 64 to be managed by a management station 76. Management station 76 can connect directly to storage router 56 via a direct connection or, alternately, can interface with storage router 56 through either Fibre Channel 52 or SCSI bus 54. In the latter case, management station 76 can be a workstation or other computing device with special rights such that storage router 56 allows access to mapping tables and shows storage devices 60, 62 and 64 as they exist physically rather than as they have been allocated.

The environment of FIG. 3 extends the concept of a single workstation having locally connected storage devices to a storage network 50 in which workstations 58 are provided virtual local storage in a manner transparent to workstations 58. Storage router 56 provides centralized control of what each workstation 58 sees as its local drive, as well as what data it sees as global data accessible by other workstations 58. Consequently, the storage space considered by the workstation 58 to be its local storage is actually a partition (i.e., logical storage definition) of a physically remote storage device 60, 62 or 64 connected through storage router 56. This means that similar requests from workstations 58 for

US 7,051,147 B2

5

access to their local storage devices produce different accesses to the storage space on storage devices 60, 62 and 64. Further, no access from a workstation 58 is allowed to the virtual local storage of another workstation 58.

The collective storage provided by storage devices 60, 62 and 64 can have blocks allocated by programming means within storage router 56. To accomplish this function, storage router 56 can include routing tables and security controls that define storage allocation for each workstation 58. The advantages provided by implementing virtual local storage in centralized storage devices include the ability to do collective backups and other collective administrative functions more easily. This is accomplished without limiting the performance of workstations 58 because storage access involves native low level, block protocols and does not involve the overhead of high level protocols and file systems required by network servers.

FIG. 4 is a block diagram of one embodiment of storage router 56 of FIG. 3. Storage router 56 can comprise a Fibre Channel controller 80 that interfaces with Fibre Channel 52 and a SCSI controller 82 that interfaces with SCSI bus 54. A buffer 84 provides memory work space and is connected to both Fibre Channel controller 80 and to SCSI controller 82. A supervisor unit 86 is connected to Fibre Channel controller 80, SCSI controller 82 and buffer 84. Supervisor unit 86 comprises a microprocessor for controlling operation of storage router 56 and to handle mapping and security access for requests between Fibre Channel 52 and SCSI bus 54.

FIG. 5 is a block diagram of one embodiment of data flow within storage router 56 of FIG. 4. As shown, data from Fibre Channel 52 is processed by a Fibre Channel (FC) protocol unit 88 and placed in a FIFO queue 90. A direct memory access (DMA) interface 92 then takes data out of FIFO queue 90 and places it in buffer 84. Supervisor unit 86 processes the data in buffer 84 as represented by supervisor processing 93. This processing involves mapping between Fibre Channel 52 and SCSI bus 54 and applying access controls and routing functions. A DMA interface 94 then pulls data from buffer 84 and places it into a buffer 96. A SCSI protocol unit 98 pulls data from buffer 96 and communicates the data on SCSI bus 54. Data flow in the reverse direction, from SCSI bus 54 to Fibre Channel 52, is accomplished in a reverse manner.

The storage router of the present invention is a bridge device that connects a Fibre Channel link directly to a SCSI bus and enables the exchange of SCSI command set information between application clients on SCSI bus devices and the Fibre Channel links. Further, the storage router applies access controls such that virtual local storage can be established in remote SCSI storage devices for workstations on the Fibre Channel link. In one embodiment, the storage router provides a connection for Fibre Channel links running the SCSI Fibre Channel Protocol (FCP) to legacy SCSI devices attached to a SCSI bus. The Fibre Channel topology is typically an Arbitrated Loop (FC\_AL).

In part, the storage router enables a migration path to Fibre Channel based, serial SCSI networks by providing connectivity for legacy SCSI bus devices. The storage router can be attached to a Fibre Channel Arbitrated Loop and a SCSI bus to support a number of SCSI devices. Using configuration settings, the storage router can make the SCSI bus devices available on the Fibre Channel network as FCP logical units. Once the configuration is defined, operation of the storage router is transparent to application clients. In this manner, the storage router can form an integral part of the

6

migration to new Fibre Channel based networks while providing a means to continue using legacy SCSI devices.

In one implementation (not shown), the storage router can be a rack mount or free standing device with an internal power supply. The storage router can have a Fibre Channel and SCSI port, and a standard, detachable power cord can be used, the FC connector can be a copper DB9 connector, and the SCSI connector can be a 68-pin type. Additional modular jacks can be provided for a serial port and a 802.3 10BaseT port, i.e. twisted pair Ethernet, for management access. The SCSI port of the storage router can support SCSI direct and sequential access target devices and can support SCSI initiators, as well. The Fibre Channel port can interface to SCSI-3 FCP enabled devices and initiators.

To accomplish its functionality, one implementation of the storage router uses: a Fibre Channel interface based on the HEWLETT-PACKARD TACHYON HPFC-5000 controller and a GLM media interface; an Intel 80960RP processor, incorporating independent data and program memory spaces, and associated logic required to implement a stand alone processing system; and a serial port for debug and system configuration. Further, this implementation includes a SCSI interface supporting Fast-20 based on the SYMBIOS 53C8xx series SCSI controllers, and an operating system based upon the WIND RIVERS SYSTEMS VXWORKS or IXWORKS kernel, as determined by design. In addition, the storage router includes software as required to control basic functions of the various elements, and to provide appropriate translations between the FC and SCSI protocols.

The storage router has various modes of operation that are possible between FC and SCSI target and initiator combinations. These modes are: FC Initiator to SCSI Target; SCSI Initiator to FC Target; SCSI Initiator to SCSI Target; and FC Initiator to FC Target. The first two modes can be supported concurrently in a single storage router device as discussed briefly below. The third mode can involve two storage router devices back to back and can serve primarily as a device to extend the physical distance beyond that possible via a direct SCSI connection. The last mode can be used to carry FC protocols encapsulated on other transmission technologies (e.g. ATM, SONET), or to act as a bridge between two FC loops (e.g. as a two port fabric).

The FC Initiator to SCSI Target mode provides for the basic configuration of a server using Fibre Channel to communicate with SCSI targets. This mode requires that a host system have an FC attached device and associated device drivers and software to generate SCSI-3 FCP requests. This system acts as an initiator using the storage router to communicate with SCSI target devices. The SCSI devices supported can include SCSI-2 compliant direct or sequential access (disk or tape) devices. The storage router serves to translate command and status information and transfer data between SCSI-3 FCP and SCSI-2, allowing the use of standard SCSI-2 devices in a Fibre Channel environment.

The SCSI Initiator to FC Target mode provides for the configuration of a server using SCSI-2 to communicate with Fibre Channel targets. This mode requires that a host system has a SCSI-2 interface and driver software to control SCSI-2 target devices. The storage router will connect to the SCSI-2 bus and respond as a target to multiple target IDs. Configuration information is required to identify the target IDs to which the bridge will respond on the SCSI-2 bus. The storage router then translates the SCSI-2 requests to SCSI-3 FCP requests, allowing the use of FC devices with a SCSI host system. This will also allow features such as a tape

US 7,051,147 B2

7

device acting as an initiator on the SCSI bus to provide full support for this type of SCSI device.

In general, user configuration of the storage router will be needed to support various functional modes of operation. Configuration can be modified, for example, through a serial port or through an Ethernet port via SNMP (simple network management protocol) or a Telnet session. Specifically, SNMP manageability can be provided via an 802.3 Ethernet interface. This can provide for configuration changes as well as providing statistics and error information. Configuration can also be performed via TELNET or RS-232 interfaces with menu driven command interfaces. Configuration information can be stored in a segment of flash memory and can be retained across resets and power off cycles. Password protection can also be provided.

In the first two modes of operation, addressing information is needed to map from FC addressing to SCSI addressing and vice versa. This can be "hard" configuration data, due to the need for address information to be maintained across initialization and partial reconfigurations of the Fibre Channel address space. In an arbitrated loop configuration, user configured addresses will be needed for AL\_PAs in order to insure that known addresses are provided between loop reconfigurations.

With respect to addressing, FCP and SCSI 2 systems employ different methods of addressing target devices. Additionally, the inclusion of a storage router means that a method of translating device IDs needs to be implemented. In addition, the storage router can respond to commands without passing the commands through to the opposite interface. This can be implemented to allow all generic FCP and SCSI commands to pass through the storage router to address attached devices, but allow for configuration and diagnostics to be performed directly on the storage router through the FC and SCSI interfaces.

Management commands are those intended to be processed by the storage router controller directly. This may include diagnostic, mode, and log commands as well as other vendor-specific commands. These commands can be received and processed by both the FCP and SCSI interfaces, but are not typically bridged to the opposite interface. These commands may also have side effects on the operation of the storage router, and cause other storage router operations to change or terminate.

A primary method of addressing management commands though the FCP and SCSI interfaces can be through peripheral device type addressing. For example, the storage router can respond to all operations addressed to logical unit (LUN) zero as a controller device. Commands that the storage router will support can include INQUIRY as well as vendor-specific management commands. These are to be generally consistent with SCC standard commands.

The SCSI bus is capable of establishing bus connections between targets. These targets may internally address logical units. Thus, the prioritized addressing scheme used by SCSI subsystems can be represented as follows: BUS:TARGET: LOGICAL UNIT. The BUS identification is intrinsic in the configuration, as a SCSI initiator is attached to only one bus. Target addressing is handled by bus arbitration from information provided to the arbitrating device. Target addresses are assigned to SCSI devices directly, though some means of configuration, such as a hardware jumper, switch setting, or device specific software configuration. As such, the SCSI protocol provides only logical unit addressing within the Identify message. Bus and target information is implied by the established connection.

8

Fibre Channel devices within a fabric are addressed by a unique port identifier. This identifier is assigned to a port during certain well-defined states of the FC protocol. Individual ports are allowed to arbitrate for a known, user defined address. If such an address is not provided, or if arbitration for a particular user address fails, the port is assigned a unique address by the FC protocol. This address is generally not guaranteed to be unique between instances. Various scenarios exist where the AL-PA of a device will change, either after power cycle or loop reconfiguration.

The FC protocol also provides a logical unit address field within command structures to provide addressing to devices internal to a port. The FCP\_CMD payload specifies an eight byte LUN field. Subsequent identification of the exchange between devices is provided by the FQXID (Fully Qualified Exchange ID).

FC ports can be required to have specific addresses assigned. Although basic functionality is not dependent on this, changes in the loop configuration could result in disk targets changing identifiers with the potential risk of data corruption or loss. This configuration can be straightforward, and can consist of providing the device a loop-unique ID (AL\_PA) in the range of "01h" to "EFh." Storage routers could be shipped with a default value with the assumption that most configurations will be using single storage routers and no other devices requesting the present ID. This would provide a minimum amount of initial configuration to the system administrator. Alternately, storage routers could be defaulted to assume any address so that configurations requiring multiple storage routers on a loop would not require that the administrator assign a unique ID to the additional storage routers.

Address translation is needed where commands are issued in the cases FC Initiator to SCSI Target and SCSI Initiator to FC Target. Target responses are qualified by the FQXID and will retain the translation acquired at the beginning of the exchange. This prevents configuration changes occurring during the course of execution of a command from causing data or state information to be inadvertently misdirected. Configuration can be required in cases of SCSI Initiator to FC Target, as discovery may not effectively allow for FCP targets to consistently be found. This is due to an FC arbitrated loop supporting addressing of a larger number of devices than a SCSI bus and the possibility of FC devices changing their AL-PA due to device insertion or other loop initialization.

In the direct method, the translation to BUS:TARGET: LUN of the SCSI address information will be direct. That is, the values represented in the FCP LUN field will directly map to the values in effect on the SCSI bus. This provides a clean translation and does not require SCSI bus discovery. It also allows devices to be dynamically added to the SCSI bus without modifying the address map. It may not allow for complete discovery by FCP initiator devices, as gaps between device addresses may halt the discovery process. Legacy SCSI device drivers typically halt discovery on a target device at the first unoccupied LUN, and proceed to the next target. This would lead to some devices not being discovered. However, this allows for hot plugged devices and other changes to the loop addressing.

In the ordered method, ordered translation requires that the storage router perform discovery on reset, and collapses the addresses on the SCSI bus to sequential FCP LUN values. Thus, the FCP LUN values 0-N can represent N+1 SCSI devices, regardless of SCSI address values, in the order in which they are isolated during the SCSI discovery process. This would allow the FCP initiator discovery pro-



US 7,051,147 B2

9

cess to identify all mapped SCSI devices without further configuration. This has the limitation that hot-plugged devices will not be identified until the next reset cycle. In this case, the address may also be altered as well.

In addition to addressing, according to the present invention, the storage router provides configuration and access controls that cause certain requests from FC Initiators to be directed to assigned virtual local storage partitioned on SCSI storage devices. For example, the same request for LUN 0 (local storage) by two different FC Initiators can be directed to two separate subsets of storage. The storage router can use tables to map, for each initiator, what storage access is available and what partition is being addressed by a particular request. In this manner, the storage space provided by SCSI storage devices can be allocated to FC initiators to provide virtual local storage as well as to create any other desired configuration for secured access.

Although the present invention has been described in detail, it should be understood that various changes, substitutions, and alterations can be made hereto without departing from the spirit and scope of the invention as defined by the appended claims.

What is claimed is:

1. A storage router for providing virtual local storage on remote storage devices to a device, comprising:

- a buffer providing memory work space for the storage router;
- a first Fibre Channel controller operable to connect to and interface with a first Fibre Channel transport medium;
- a second Fibre Channel controller operable to connect to and interface with a second Fibre Channel transport medium; and
- a supervisor unit coupled to the first and second Fibre Channel controllers and the buffer, the supervisor unit operable:
  - to maintain a configuration for remote storage devices connected to the second Fibre Channel transport medium that maps between the device and the remote storage devices and that implements access controls for storage space on the remote storage devices; and
  - to process data in the buffer to interface between the first Fibre Channel controller and the second Fibre Channel controller to allow access from Fibre Channel initiator devices to the remote storage devices using native low level, block protocol in accordance with the configuration.

2. The storage router of claim 1, wherein the configuration maintained by the supervisor unit includes an allocation of subsets of storage space to associated Fibre Channel devices, wherein each subset is only accessible by the associated Fibre Channel device.

3. The storage router of claim 2, wherein the Fibre Channel devices comprise workstations.

4. The storage router of claim 2, wherein the remote storage devices comprise hard disk drives.

5. The storage router of claim 1, wherein each of the first Fibre Channel controller comprises:

- a Fibre Channel (FC) protocol unit operable to connect to the Fibre Channel transport medium;
- a first-in-first-out queue coupled to the Fibre Channel protocol unit; and
- a direct memory access (DMA) interface coupled to the first-in-first-out queue and to the buffer.

6. A storage network, comprising:

- a first Fibre Channel transport medium;
- a second Fibre Channel transport medium;

10

a plurality of workstations connected to the first Fibre Channel transport medium;

a plurality of storage devices connected to the second Fibre Channel transport medium; and

a storage router interfacing between the first Fibre Channel transport medium and the second Fibre Channel transport medium, the storage router providing virtual local storage on the storage devices to the workstations and operable:

- to map between the workstations and the storage devices;
- to implement access controls for storage space on the storage devices; and
- to allow access from the workstations to the storage devices using native low level, block protocol in accordance with the mapping and access controls.

7. The storage network of claim 6, wherein the access controls include an allocation of subsets of storage space to associated workstations, wherein each subset is only accessible by the associated workstation.

8. The storage network of claim 6, wherein the storage devices comprise hard disk drives.

9. The storage network of claim 6, wherein the storage router comprises:

- a buffer providing memory work space for the storage router;
- a first Fibre Channel controller operable to connect to and interface with the first Fibre Channel transport medium, the first Fibre Channel controller further operable to pull outgoing data from the buffer and to place incoming data into the buffer;
- a second Fibre Channel controller operable to connect to and interface with the second Fibre Channel transport medium, the second Fibre Channel controller further operable to pull outgoing data from the buffer and to place incoming data into the buffer; and
- a supervisor unit coupled to the first and second Fibre Channel controllers and the buffer, the supervisor unit operable:
  - to maintain a configuration for the storage devices that maps between workstations and storage devices and that implements the access controls for storage space on the storage devices; and
  - to process data in the buffer to interface between the first Fibre Channel controller and the second Fibre Channel controller to allow access from workstations to storage devices in accordance with the configuration.

10. A method for providing virtual local storage on remote storage devices to Fibre Channel devices, comprising:

- interfacing with a first Fibre Channel transport medium;
- interfacing with a second Fibre Channel transport medium;
- maintaining a configuration for remote storage devices connected to the second Fibre Channel transport medium that maps between Fibre Channel devices and the remote storage devices and that implements access controls for storage space on the remote storage devices; and
- allowing access from Fibre Channel initiator devices to the remote storage devices using native low level, block protocol in accordance with the configuration.

11. The method of claim 10, wherein maintaining the configuration includes allocating subsets of storage space to associated Fibre Channel devices, wherein each subset is only accessible by the associated Fibre Channel device.

US 7,051,147 B2

11

12. The method of claim 11, wherein the Fibre Channel devices comprise workstations.

13. The method of claim 11, wherein the remote storage devices comprise hard disk drives.

14. An apparatus for providing virtual local storage on a remote storage device to a device operating according to a Fibre Channel protocol, comprising:

a first controller operable to connect to and interface with a first transport medium, wherein the first transport medium is operable according to the Fibre Channel protocol;

a second controller operable to connect to and interface with a second transport medium, wherein the second transport medium is operable according to the Fibre Channel protocol; and

a supervisor unit coupled to the first controller and the second controller, the supervisor unit operable to control access from the device connected to the first transport medium to the remote storage device connected to the second transport medium using native low level, block protocols according to a map between the device and the remote storage device.

15. The apparatus of claim 14, wherein the supervisor unit is further operable to maintain a configuration wherein the configuration includes the map between the device and the remote storage device, and further wherein the map includes virtual LUNs that provide a representation of the storage device.

16. The apparatus of claim 15, wherein the map only exposes the device to LUNs that the device may access.

17. The apparatus of claim 14, wherein the supervisor unit is further operable to maintain a configuration including the map, wherein the map provides a mapping from a host device ID to a virtual LUN representation of the remote storage device to a physical LUN of the remote storage device.

18. The apparatus of claim 14, wherein the remote storage device further comprises storage space partitioned into virtual local storage for the device connected to the first transport medium.

19. The apparatus of claim 18, wherein the supervisor unit is further operable to prevent the device from accessing any storage on the remote storage device that is not part of a virtual local storage partition assigned to the device.

20. The apparatus of claim 14, wherein the first controller and the second controller further comprise a single controller.

21. A system for providing virtual local storage on remote storage devices, comprising:

a first controller operable to connect to and interface with a first transport medium operable according to a Fibre Channel protocol;

a second controller operable to connect to and interface with a second transport medium operable according to the Fibre Channel protocol;

at least one device connected to the first transport medium;

at least one storage device connected to the second transport medium; and

an access control device coupled to the first controller and the second controller, the access control device operable to:

map between the at least one device and a storage space on the at least one storage device; and

control access from the at least one device to the at least one storage device using native low level, block protocol in accordance with the map.

12

22. The system of claim 21, wherein the access control device is further operable to maintain a configuration wherein the configuration includes the map between the at least one device and the at least one storage device, and further wherein the map includes virtual LUNs that provide a representation of the at least one storage device.

23. The system of claim 22, wherein the map only exposes the at least one device to LUNs that the at least one device may access.

24. The system of claim 21, wherein the access control device is further operable to maintain a configuration including the map, wherein the map provides a mapping from a host device ID to a virtual LUN representation of the at least one storage device to a physical LUN of the at least one storage device.

25. The system of claim 21, wherein the at least one storage device further comprises storage space partitioned into virtual local storage for the at least one device.

26. The system of claim 25, wherein the access control unit is further operable to prevent at least one device from accessing any storage on the at least one storage device that is not part of a virtual local storage partition assigned to the at least one device.

27. The system of claim 21, wherein the first controller and the second controller further comprise a single controller.

28. A method for providing virtual local storage on remote storage devices, comprising:

mapping between a device connected to a first transport medium and a storage device connected to a second transport medium, wherein the first transport medium and the second transport medium operate according to a Fibre Channel protocol;

implementing access controls for storage space on the storage device; and

allowing access from the device connected to the first transport medium to the storage device using native low level, block protocols.

29. The method of claim 28, further comprising maintaining a configuration wherein the configuration includes a map between the device and the one storage device, and further wherein the map includes virtual LUNs that provide a representation of the storage device.

30. The method of claim 29, wherein the map only exposes the device to LUNs that the device may access.

31. The method of claim 28, further comprising maintaining a configuration including a map from a host device ID to a virtual LUN representation of the storage device to a physical LUN of the storage device.

32. The method of claim 28, further comprising partitioning storage space on the storage device into virtual local storage for the device.

33. The method of claim 32, further comprising preventing the device from accessing any storage on the storage device that is not part of a virtual local storage partition assigned to the device.

34. A system for providing virtual local storage, comprising:

a host device;

a storage device remote from the host device, wherein the storage device has a storage space;

a first controller;

a second controller

a first transport medium operable according to a Fibre Channel protocol, wherein the first transport medium connects the host device to the first controller;

US 7,051,147 B2

13

a second transport medium operable according to the Fibre Channel protocol, wherein the second transport medium connects the second controller to the storage device;  
a supervisor unit coupled to the first controller and the second controller, the supervisor unit operable to:  
maintain a configuration that maps between the host device and at least a portion of the storage space on the storage device; and  
implement access controls according to the configuration for the storage space on the storage device using native low level, block protocol.  
35. The system of claim 34, wherein the supervisor unit is further operable to:  
maintain a configuration that maps from the host device to a virtual representation of at least a portion of the storage space on the storage device to the storage device; and

14

allow the host device to access only that portion of the storage space that is contained in the map.  
36. The system of claim 35, wherein the configuration comprises a map from a host device ID to a virtual LUN representation of the storage device to a physical LUN of the storage device.  
37. The system of claim 34, wherein the storage device further comprises storage space partitioned into virtual local storage for the host device.  
38. The system of claim 37, wherein the supervisor unit is further operable to prevent the host device from accessing any storage on the storage device that is not part of a virtual local storage partition assigned to the host device.  
39. The apparatus of claim 34, wherein the first controller and the second controller further comprise a single controller.

\* \* \* \* \*



# **EXHIBIT D**

(12) **United States Patent**  
**Hoese et al.**

(10) **Patent No.:** US 7,987,311 B2  
 (45) **Date of Patent:** Jul. 26, 2011

(54) **STORAGE ROUTER AND METHOD FOR PROVIDING VIRTUAL LOCAL STORAGE**  
 (75) Inventors: **Geoffrey B. Hoese**, Austin, TX (US);  
**Jeffrey T. Russell**, Cibolo, TX (US)  
 (73) Assignee: **Crossroads Systems, Inc.**, Austin, TX (US)  
 (\* ) Notice: Subject to any disclaimer, the term of this patent is extended or adjusted under 35 U.S.C. 154(b) by 0 days.

(21) Appl. No.: **12/910,515**  
 (22) Filed: **Oct. 22, 2010**  
 (65) **Prior Publication Data**  
 US 2011/0035528 A1 Feb. 10, 2011

**Related U.S. Application Data**  
 (63) Continuation of application No. 12/552,807, filed on Sep. 2, 2009, which is a continuation of application No. 11/851,724, filed on Sep. 7, 2007, now Pat. No. 7,689,754, which is a continuation of application No. 11/442,878, filed on May 30, 2006, now abandoned, which is a continuation of application No. 11/353,826, filed on Feb. 14, 2006, now Pat. No. 7,340,549, which is a continuation of application No. 10/658,163, filed on Sep. 9, 2003, now Pat. No. 7,051,147, which is a continuation of application No. 10/081,110, filed on Feb. 22, 2002, now Pat. No. 6,789,152, which is a continuation of application No. 09/354,682, filed on Jul. 15, 1999, now Pat. No. 6,421,753, which is a continuation of application No. 09/001,799, filed on Dec. 31, 1997, now Pat. No. 5,941,972.

(51) **Int. Cl.**  
**G06F 13/00** (2006.01)  
**G06F 3/00** (2006.01)  
 (52) **U.S. Cl.** ..... **710/305; 710/11; 709/258**

(58) **Field of Classification Search** ..... 710/1-5, 710/8-13, 36-38, 126-131, 250, 305; 709/258; 714/42; 711/110-113  
 See application file for complete search history.

(56) **References Cited**  
 U.S. PATENT DOCUMENTS  
 3,082,406 A 3/1963 Stevens  
 (Continued)  
 FOREIGN PATENT DOCUMENTS  
 AU 647414 3/1994  
 (Continued)  
 OTHER PUBLICATIONS  
 Black Box, SCSI Fiberoptic Extender, Single-Ended, Product Insert, 2 pages, 1996, Jun. 18, 1905.  
 (Continued)

*Primary Examiner* — Christopher B Shin  
 (74) *Attorney, Agent, or Firm* — Sprinkle IP Law Group

(57) **ABSTRACT**  
 A storage router and method for providing virtual local storage on remote storage devices to devices are provided. Devices are connected to a first transport medium, and a plurality of storage devices are connected to a second transport medium. In one embodiment, the storage router maintains a map to allocate storage space on the remote storage devices to devices connected to the first transport medium by associating representations of the devices connected to the first transport medium with representations of storage space on the remote storage devices, wherein each representation of a device connected to the first transport medium is associated with one or more representations of storage space on the remote storage devices and controls access from the devices connected to the first transport medium to the storage space on the remote storage devices in accordance with the map and using native low level block protocol.

**28 Claims, 2 Drawing Sheets**

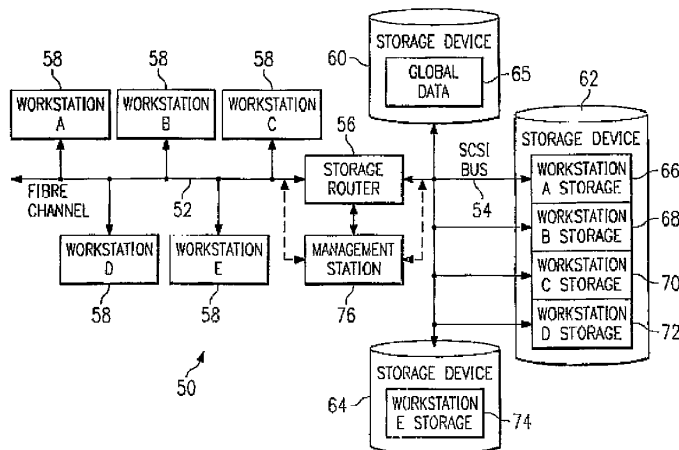

## US 7,987,311 B2

Page 2

| U.S. PATENT DOCUMENTS |   |         |                    |           |   |         |                     |
|-----------------------|---|---------|--------------------|-----------|---|---------|---------------------|
| 4,092,732             | A | 5/1978  | Ouchi              | 5,469,576 | A | 11/1995 | Dauerer et al.      |
| 4,170,415             | A | 10/1979 | Lemeshewsky et al. | 5,471,609 | A | 11/1995 | Yudenfriend et al.  |
| 4,415,970             | A | 11/1983 | Swenson et al.     | 5,487,077 | A | 1/1996  | Hassner et al.      |
| 4,455,605             | A | 6/1984  | Cormier et al.     | 5,491,812 | A | 2/1996  | Pisello et al.      |
| 4,504,927             | A | 3/1985  | Callan             | 5,495,474 | A | 2/1996  | Olnowich et al.     |
| 4,533,996             | A | 8/1985  | Gartung et al.     | 5,496,576 | A | 3/1996  | Jeong               |
| 4,573,152             | A | 2/1986  | Greene et al.      | 5,504,857 | A | 4/1996  | Baird et al.        |
| 4,603,380             | A | 7/1986  | Easton et al.      | 5,507,032 | A | 4/1996  | Kimura              |
| 4,620,295             | A | 10/1986 | Aiden, Jr.         | 5,511,169 | A | 4/1996  | Suda                |
| 4,644,462             | A | 2/1987  | Matsubara et al.   | 5,519,695 | A | 5/1996  | Purohit et al.      |
| 4,695,948             | A | 9/1987  | Blevins et al.     | 5,530,845 | A | 6/1996  | Hiatt et al.        |
| 4,697,232             | A | 9/1987  | Brunelle et al.    | 5,535,352 | A | 7/1996  | Bridges et al.      |
| 4,715,030             | A | 12/1987 | Koch et al.        | 5,537,585 | A | 7/1996  | Blickenstaff et al. |
| 4,751,635             | A | 6/1988  | Kret               | 5,544,313 | A | 8/1996  | Shachnai et al.     |
| 4,787,028             | A | 11/1988 | Finrock et al.     | 5,548,791 | A | 8/1996  | Casper et al.       |
| 4,807,180             | A | 2/1989  | Takeuchi et al.    | 5,564,019 | A | 10/1996 | Beausoleil et al.   |
| 4,811,278             | A | 3/1989  | Bean et al.        | 5,568,648 | A | 10/1996 | Coscarella et al.   |
| 4,821,179             | A | 4/1989  | Jensen et al.      | 5,571,971 | A | 11/1996 | Chastel et al.      |
| 4,825,406             | A | 4/1989  | Bean et al.        | 5,581,709 | A | 12/1996 | Ito et al.          |
| 4,827,411             | A | 5/1989  | Arrowood et al.    | 5,581,714 | A | 12/1996 | Amini et al.        |
| 4,835,674             | A | 5/1989  | Collins et al.     | 5,581,724 | A | 12/1996 | Belsan et al.       |
| 4,845,722             | A | 7/1989  | Kent et al.        | 5,596,562 | A | 1/1997  | Chen                |
| 4,864,532             | A | 9/1989  | Reeve et al.       | 5,596,736 | A | 1/1997  | Kerns               |
| 4,897,874             | A | 1/1990  | Lidensky et al.    | 5,598,541 | A | 1/1997  | Malladi             |
| 4,947,367             | A | 8/1990  | Chang et al.       | 5,613,082 | A | 3/1997  | Brewer et al.       |
| 4,961,224             | A | 10/1990 | Yung               | 5,621,902 | A | 4/1997  | Cases et al.        |
| 5,072,378             | A | 12/1991 | Manka              | 5,632,012 | A | 5/1997  | Belsan et al.       |
| 5,077,732             | A | 12/1991 | Fischer et al.     | 5,634,111 | A | 5/1997  | Oeda et al.         |
| 5,077,736             | A | 12/1991 | Dunphy, Jr. et al. | 5,638,518 | A | 6/1997  | Malladi             |
| 5,124,987             | A | 6/1992  | Milligan et al.    | 5,642,515 | A | 6/1997  | Jones et al.        |
| 5,155,845             | A | 10/1992 | Beal et al.        | 5,659,756 | A | 8/1997  | Hefferon et al.     |
| 5,163,131             | A | 11/1992 | Row et al.         | 5,664,107 | A | 9/1997  | Chatwanni et al.    |
| 5,185,876             | A | 2/1993  | Nguyen et al.      | 5,680,556 | A | 10/1997 | Begun et al.        |
| 5,193,168             | A | 3/1993  | Corrigan et al.    | 5,684,800 | A | 11/1997 | Dobbins et al.      |
| 5,193,184             | A | 3/1993  | Belsan et al.      | 5,701,491 | A | 12/1997 | Dunn et al.         |
| 5,202,856             | A | 4/1993  | Glider et al.      | 5,712,976 | A | 1/1998  | Falcon et al.       |
| 5,210,866             | A | 5/1993  | Milligan et al.    | 5,727,218 | A | 3/1998  | Hotchkin            |
| 5,212,785             | A | 5/1993  | Powers et al.      | 5,729,705 | A | 3/1998  | Weber               |
| 5,214,778             | A | 5/1993  | Glider et al.      | 5,743,847 | A | 4/1998  | Nakamura et al.     |
| 5,226,143             | A | 7/1993  | Baird et al.       | 5,748,924 | A | 5/1998  | Llorens et al.      |
| 5,239,632             | A | 8/1993  | Larner             | 5,751,975 | A | 5/1998  | Gillespie et al.    |
| 5,239,643             | A | 8/1993  | Blount et al.      | 5,764,931 | A | 6/1998  | Schmahl et al.      |
| 5,239,654             | A | 8/1993  | Ing-Simmons et al. | 5,768,623 | A | 6/1998  | Judd et al.         |
| 5,247,638             | A | 9/1993  | O'Brien et al.     | 5,774,683 | A | 6/1998  | Gulick              |
| 5,247,692             | A | 9/1993  | Fujimura           | 5,778,411 | A | 7/1998  | DeMoss              |
| 5,257,386             | A | 10/1993 | Saito              | 5,781,715 | A | 7/1998  | Sheu                |
| 5,297,262             | A | 3/1994  | Cox et al.         | 5,802,278 | A | 9/1998  | Isfeld et al.       |
| 5,301,290             | A | 4/1994  | Tetzlaff et al.    | 5,805,816 | A | 9/1998  | Picazo, Jr. et al.  |
| 5,315,657             | A | 5/1994  | Abadi et al.       | 5,805,920 | A | 9/1998  | Sprenkle et al.     |
| 5,317,693             | A | 5/1994  | Cuenod et al.      | 5,809,328 | A | 9/1998  | Nogales et al.      |
| 5,331,673             | A | 7/1994  | Elko et al.        | 5,812,754 | A | 9/1998  | Lui et al.          |
| 5,347,384             | A | 9/1994  | McReynolds et al.  | 5,819,054 | A | 10/1998 | Ninomiyama et al.   |
| 5,355,453             | A | 10/1994 | Row et al.         | 5,825,772 | A | 10/1998 | Dobbins et al.      |
| 5,361,347             | A | 11/1994 | Glider et al.      | 5,835,496 | A | 11/1998 | Yeung et al.        |
| 5,367,646             | A | 11/1994 | Pardillos et al.   | 5,845,107 | A | 12/1998 | Fisch et al.        |
| 5,379,385             | A | 1/1995  | Shomler            | 5,848,251 | A | 12/1998 | Lomelino et al.     |
| 5,379,398             | A | 1/1995  | Cohn et al.        | 5,857,080 | A | 1/1999  | Jander et al.       |
| 5,388,243             | A | 2/1995  | Glider et al.      | 5,860,137 | A | 1/1999  | Raz et al.          |
| 5,388,246             | A | 2/1995  | Kasi               | 5,864,653 | A | 1/1999  | Tavallaei et al.    |
| 5,394,402             | A | 2/1995  | Ross et al.        | 5,867,648 | A | 2/1999  | Foth et al.         |
| 5,394,526             | A | 2/1995  | Crouse et al.      | 5,881,311 | A | 3/1999  | Woods               |
| 5,396,596             | A | 3/1995  | Hashemi et al.     | 5,884,027 | A | 3/1999  | Garbus et al.       |
| 5,403,639             | A | 4/1995  | Belsan et al.      | 5,889,952 | A | 3/1999  | Hunnicut et al.     |
| 5,410,667             | A | 4/1995  | Belsan et al.      | 5,913,045 | A | 6/1999  | Gillespie et al.    |
| 5,410,697             | A | 4/1995  | Baird et al.       | 5,923,557 | A | 7/1999  | Eidson              |
| 5,414,820             | A | 5/1995  | McFarland et al.   | 5,933,824 | A | 8/1999  | DeKoning et al.     |
| 5,416,915             | A | 5/1995  | Mattson et al.     | 5,935,205 | A | 8/1999  | Murayama et al.     |
| 5,418,909             | A | 5/1995  | Jachowski et al.   | 5,935,260 | A | 8/1999  | Ofar                |
| 5,420,988             | A | 5/1995  | Elliott            | 5,941,969 | A | 8/1999  | Ram et al.          |
| 5,423,026             | A | 6/1995  | Cook et al.        | 5,941,972 | A | 8/1999  | Hoese et al.        |
| 5,423,044             | A | 6/1995  | Sutton et al.      | 5,946,308 | A | 8/1999  | Dobbins et al.      |
| 5,426,637             | A | 6/1995  | Derby et al.       | 5,953,511 | A | 9/1999  | Sescila et al.      |
| 5,430,855             | A | 7/1995  | Wash et al.        | 5,959,994 | A | 9/1999  | Boggs et al.        |
| 5,450,570             | A | 9/1995  | Richek et al.      | 5,963,556 | A | 10/1999 | Varghese et al.     |
| 5,452,421             | A | 9/1995  | Beardsley et al.   | 5,974,530 | A | 10/1999 | Young               |
| 5,459,857             | A | 10/1995 | Ludlam et al.      | 5,978,379 | A | 11/1999 | Chan et al.         |
| 5,463,754             | A | 10/1995 | Beausoleil et al.  | 5,978,875 | A | 11/1999 | Asano et al.        |
| 5,465,382             | A | 11/1995 | Day, III et al.    | 5,991,797 | A | 11/1999 | Futral et al.       |
|                       |   |         |                    | 6,000,020 | A | 12/1999 | Chin et al.         |



US 7,987,311 B2

Page 3

6,021,451 A 2/2000 Bell et al.  
 6,029,168 A 2/2000 Frey  
 6,032,269 A 2/2000 Renner, Jr.  
 6,041,058 A 3/2000 Flanders et al.  
 6,041,381 A 3/2000 Hoese  
 6,055,603 A 4/2000 Ofer et al.  
 6,065,087 A 5/2000 Keaveny et al.  
 6,070,253 A 5/2000 Tavallaee et al.  
 6,073,209 A 6/2000 Bergsten  
 6,073,218 A 6/2000 DeKoning et al.  
 6,075,863 A 6/2000 Krishnan et al.  
 6,081,849 A 6/2000 Born et al.  
 6,098,128 A 8/2000 Velez-McCaskey et al.  
 6,098,149 A 8/2000 Ofer et al.  
 6,108,684 A 8/2000 DeKoning et al.  
 6,118,766 A 9/2000 Akers  
 6,131,119 A 10/2000 Fukui  
 6,134,617 A 10/2000 Weber  
 6,141,737 A 10/2000 Krantz et al.  
 6,145,006 A 11/2000 Vishlitsky et al.  
 6,147,976 A 11/2000 Shand et al.  
 6,147,995 A 11/2000 Dobbins et al.  
 6,148,004 A 11/2000 Nelson et al.  
 6,173,399 B1 1/2001 Gilbrech  
 6,185,203 B1 2/2001 Berman  
 6,202,153 B1 3/2001 Diamant et al.  
 6,209,023 B1 3/2001 Dimitroff et al.  
 6,219,771 B1 4/2001 Kikuchi et al.  
 6,223,266 B1 4/2001 Sartore  
 6,230,218 B1 5/2001 Casper et al.  
 6,243,827 B1 6/2001 Renner, Jr.  
 6,260,120 B1 7/2001 Blumenau et al.  
 6,268,789 B1 7/2001 Diamant et al.  
 6,308,247 B1 10/2001 Ackerman  
 6,330,629 B1 12/2001 Kondo et al.  
 6,330,687 B1 12/2001 Griffith  
 6,341,315 B1 1/2002 Arroyo et al.  
 6,343,324 B1 1/2002 Hubis et al.  
 6,363,462 B1 3/2002 Bergsten  
 6,401,170 B1 6/2002 Griffith et al.  
 6,421,753 B1 7/2002 Hoese et al.  
 6,425,035 B2 7/2002 Hoese et al.  
 6,425,036 B2 7/2002 Hoese et al.  
 6,425,052 B1 7/2002 Hashemi  
 6,453,345 B2 9/2002 Trcka et al.  
 6,484,245 B1 11/2002 Sanada et al.  
 D470,486 S 2/2003 Cheng  
 6,529,996 B1 3/2003 Nguyen et al.  
 6,547,576 B2 4/2003 Peng et al.  
 6,560,750 B2 5/2003 Chien et al.  
 6,563,701 B1 5/2003 Peng et al.  
 6,775,693 B1 8/2004 Adams  
 6,792,602 B2 9/2004 Lin et al.  
 6,820,212 B2 11/2004 Duchesne et al.  
 6,854,027 B2 2/2005 Hsu et al.  
 6,862,637 B1 3/2005 Stupar  
 6,874,043 B2 3/2005 Treggiden  
 6,874,100 B2 3/2005 Rauscher  
 6,910,083 B2 6/2005 Hsu et al.  
 7,065,076 B1 6/2006 Nemazie  
 0,218,322 A1 9/2006 Hoese et al.  
 7,127,668 B2 10/2006 McBryde et al.  
 7,133,965 B2 11/2006 Chien  
 7,188,111 B2 3/2007 Chen et al.  
 7,216,225 B2 5/2007 Haviv et al.  
 7,251,248 B2 7/2007 Trossell et al.  
 7,281,072 B2 10/2007 Liu et al.  
 2002/0083221 A1 6/2002 Tsai et al.  
 2006/0277326 A1 12/2006 Tsai et al.  
 2006/0294416 A1 12/2006 Tsai et al.  
 2009/0319715 A1\* 12/2009 Hoese et al. .... 710/315

FOREIGN PATENT DOCUMENTS

AU 670376 7/1996  
 CA 2066443 10/2003  
 EP 0810530 A2 12/1997  
 EP 0490973 2/1998  
 EP 0827059 A2 3/1998  
 GB 2296798 A 7/1996

GB 2297636 A 8/1996  
 GB 2341715 3/2000  
 IL 095447 5/1994  
 IL 107645 9/1996  
 JP 5502525 4/1993  
 JP 5181609 7/1993  
 JP 1993181609 7/1993  
 JP 6301607 10/1994  
 JP 720994 1/1995  
 JP 1995020994 1/1995  
 JP 8-230895 9/1996  
 JP 09-185594 7/1997  
 JP 1997185594 7/1997  
 JP 09-251437 9/1997  
 JP 1997251437 9/1997  
 JP 10097493 4/1998  
 WO WO 91/03788 3/1991  
 WO WO 9733227 9/1997  
 WO WO 98/36357 8/1998  
 WO WO 99/34297 A1 7/1999

OTHER PUBLICATIONS

Block-Based Distributed File Systems, Anthony J. McGregor, Jul. 1997.  
 Compaq StorageWorks HSG80 Array Controller ACS Version 8.3 (Maintenance and Service Guide) Nov. 1998.  
 Compaq StorageWorks HSG80 Array Controller ACS Version 8.3 (Configuration and CLI Reference Guide) Nov. 1998.  
 CRD-5500, Raid Disk Array Controller Product Insert, pp. 1-5.  
 CRD-5500, SCSI Raid Controller OEM Manual, Rev. 1.3, Feb. 26, 1996, pp. 1-54, Feb. 26, 1996.  
 CRD-5500, SCSI Raid Controller Users Manual, Rev. 1.3, Nov. 21, 1996, pp. 10-92, Nov. 21, 1996.  
 Digital StorageWorks HSZ70 Array Controller HSOE Version 7.0 EK-SHZ70-RM.A01 CLI Reference Manual. Jul. 1, 1997.  
 Digital Storage Works, HSZ70 Array Controller, HSOE Version 7.0 EK-HSZ70-CG. A01, Digital Equipment Corporation, Maynard, Massachusetts, Jul. 1, 1997.  
 Digital StorageWorks, Using Your HSZ70 Array Controller in a SCSI Controller Shelf (DS-BA356-M Series), User's Guide, pp. 1-1 through A-5 with index, Jan. 1998.  
 Digital StorageWorks HSZ70 Array Controller HSOE Version 7.0 EK-HSZ70-SV. A01, 1997.  
 Digital StorageWorks HSG80 Array Controller ACS Version 8.0 (User's Guide Jan. 1998).  
 DP5380 Asynchronous SCSI Interface, National Semiconductor Corporation, Arlington, TX, May 1989, pp. 1-32.  
 Emerson, "Encor Communications: Performance evaluation of switched fibre channel I/O system using—FCP for SCSI" Feb. 1995, IEEE, pp. 479-484.  
 Fiber channel (FCS)/ATM internetworking: a design solution.  
 Fiber Channel storage interface for video-on-demand servers by Anazaloni, et al., Jun. 15, 1995.  
 Fibre Channel and ATM: The Physical Layers, Jerry Quam WESCON/94, published Sep. 27-29, 1994, pp. 648-652.  
 Gen5 S-Series XL System Guide Revision 1.01 by Chen, Jun. 18, 1995.  
 Graphical User Interface for MAXSTRAT Gen5/Gen-S Servers User's guide 1.1, Jun. 11, 1996.  
 High Performance Data transfers Using Network-Attached Peripherals at the national Storage Laboratory by Hyer, Feb. 26, 1993.  
 IFT-3000 SCSI to SCSI Disk array Controller Instruction Manual Revision 2.0 by Infotrend Technologies, Inc., 1995.  
 Implementing a Fibre Channel SCSI transport by Snively, 1994.  
 "InfoServer 150—Installation and Owner's Guide", EK-INFSV-OM-001, Digital Equipment Corporation, Maynard, Massachusetts 1991, Chapters 1 and 2.  
 InfoServer 150VXT Photograph.  
 IBM Technical Publication: Guide to Sharing and Partitioning IBM Tape Library Dataservers, Nov. 1996, pp. 1-256, Nov. 1, 1996.  
 IBM Technical Publication: Magstar and IBM 3590 High Performance Tape Subsystem Technical Guide, Nov. 1996, pp. 1-269.  
 Misc. Reference Manual Pages, SunOS 5.09.

## US 7,987,311 B2

Page 4

- InfoServer 100 System Operations Guide, First Edition Digital Equipment Corporation, 1990.
- Johnson, D.B., et al., The Peregrine High Performance RPC System, Software-Practice and Experience, 23(2):201-221, Feb. 1993.
- Local-Area networks for the IBM PC by Haugdahl.
- New serial I/Os speed storage subsystems by Bursky, Feb. 6, 1995.
- Petal: Distributed Virtual Disks, Edward K. Lee and Chandramohan A. Thekkath, ACM SIGPLAN Notices, vol. 31, Issue 9, Sep. 1996, pp. 84-92.
- Pictures of internal components of the InfoServer 150, taken from <http://bindarydinosaurs.couk/Museum/Digital/infoserver/infoserver.php> in Nov. 2004.
- Raidtec FibreArray and Raidtec FlexArray UltraRAID Systems, Windows IT PRO Article, Oct. 1997.
- S.P. Joshi, "Ethernet controller chip interfaces with variety of 16-bit processors," electronic Design, Hayden Publishing Co., Inc., Rochelle Park, NJ, Oct. 14, 1982. pp. 193-200.
- Simplest Migration to Fibre Channel Technology Article, Digital Equipment Corporation, Nov. 10, 1997, published on PR Newswire, Nov. 10, 1997.
- Systems Architectures Using Fibre Channel, Roger Cummings, Twelfth IEEE Symposium on Mass Storage Systems, Copyright 1993 IEEE. pp. 251-256.
- Office Action dated Jan. 21, 2003 for U.S. Appl. No. 10/174,720, Jan. 21, 2003.
- Office Action dated Feb. 27, 2001 for U.S. Appl. No. 09/354,682.
- Office Action dated Aug. 11, 2000 for U.S. Appl. No. 09/354,682.
- Office Action dated Dec. 16, 1999 for U.S. Appl. No. 09/354,682.
- Office Action dated Nov. 6, 2002 for U.S. Appl. No. 10/023,786.
- Office Action dated Jan. 21, 2003 for U.S. Appl. No. 10/081,110.
- Office Action in Ex Parte Reexamination 90/007,127, mailed Feb. 7, 2005.
- Office Action in Ex Parte Reexamination 90/007,125, mailed Feb. 7, 2005.
- Office Action in Ex Parte Reexamination 90/007,126, mailed Feb. 7, 2005.
- Office Action in Ex Parte Reexamination 90/007,124, mailed Feb. 7, 2005.
- Office Action in Ex Parte Reexamination 90/007,123, mailed Feb. 7, 2005.
- European Office Action issued Apr. 1, 2004 in Application No. 98966104.6-2413.
- Office Action dated Jan. 27, 2005 in U.S. Appl. No. 10/658,163.
- Digital "System Support Addendum", SSA 40.78.01-A, AE-PNZJB-TE, pp. 1-3, Apr. 1, 1993.
- Digital "Software Product Description", SSA 40.78.01, AE-PNZJB-TE, pp. 1-3, Apr. 1, 1993.
- Digital Equipment Corporation, "InfoServer 100 Installation and Owner's Guide", Order No. EK-DIS1K-IN-001, First Edition, Oct. 1, 1990.
- Digital Equipment Corporation, "InfoServer 100 System Operation Guide", Order No. EK-DIS1K-UG-001, First Edition, pp. i-Index 5, Oct. 1, 1990.
- Elliott, Working Draft American National Standard, Project T10/1562-D, Revision 5, pp. i-432, Jul. 9, 2003.
- Satran, "Standards-Track," May 2001, iSCSI, pp. 9-87, Nov. 1, 2000.
- Satran, et al. IPS Internet Draft, iSCSI, pp. 1-8, Nov. 1, 2000.
- APT Technologies, Inc., "Serial ATA: High Speed Serialized AT Attachment", Rev. 1.0a, pp. 1-310, Jan. 7, 2003.
- Defendant's First Supplemental Trial Exhibit List, *Crossroads Systems, Inc., v. Chaparral Network Storage, Inc.*, C.A. No. A-00CA-217-SS (W.D. Tex. 2001). (CD-Rom).
- Defendant's Third Supplemental Trial Exhibit List, *Crossroads Systems, Inc. v. Pathlight Technology, Inc.*, C.A. No. A-00CA-248-SS (W.D. Tex. 2001) (CD-Rom).
- Plaintiffs Fourth Amended Trial Exhibit List, *Crossroads Systems, Inc. v. Chaparral Network Storage, Inc.*, C.A. No. A-00CA-217-SS (W.D. Tex. 2001) (CD-Rom).
- Plaintiffs Revised Trial Exhibit List, *Crossroads Systems, Inc. v. Pathlight Technology, Inc.*, C.A. No. A-00CA-248-SS (W.D. Tex. 2001). (CD-Rom).
- Trail Transcripts, *Crossroads Systems, Inc. v. Chaparral Network Storage, Inc.*, C.A. No. A-00CA-217-SS (W.D. Tex. 2001) Day 1 -5 (CD-Rom).
- Trail Transcripts, *Crossroads Systems, Inc. v. Pathlight Technology, Inc.*, C.A. No. A-00CA-248-SS (W.D. Tex. 2001). Day 1-4 (CD-Rom).
- Datasheet for CrossPoint 4100 Fibre Channel to SCSI Router (Dedek Ex 41 (ANCT 117-120)) (CD-ROM Chaparral Exhibits D012).
- Symbios Logic—Software Interface Specification Series 3 SCSI RAID Controller Software Release 02.xx (Engelbrecht Ex 2 (LSI 1421-1658)) (CD-ROM Chaparral Exhibits D013), Dec. 3, 1997.
- Press Release—Symbios Logic to Demonstrate Strong Support for Fibre Channel at Fall Comdex (Engelbrecht 12 (LSI 2785-86)) (CD-ROM Chaparral Exhibits D016), Nov. 13, 1996.
- OEM Datasheet on the 3701 Controller (Engelbrecht 13 (LSI 01837-38)) (CD-ROM Chaparral Exhibits D017), Jun. 17, 1995.
- Nondisclosure Agreement Between Adaptec and Crossroads Dated Oct. 17, 1996 (Quisenberry Ex 25 (CRDS 8196)) (CD-ROM Chaparral Exhibits D020), Oct. 17, 1996.
- Organizational Presentation on the External Storage Group (Lavan Ex 1 (CNS 182242-255)) (CD-ROM Chaparral Exhibits D021), Apr. 11, 1996.
- Bridge Phase II Architecture Presentation (Lavan Ex 2 (CNS 182287-295)) (CD-ROM Chaparral Exhibits D022), Apr. 12, 1996.
- Bridge. C, Bridge Between SCSI-2 and SCSI-3 FCP (Fibre Channel Protocol) (CD-ROM Chaparral Exhibits P214).
- Attendees/Action Items from Apr. 12, 1996 Meeting at BTC (Lavan Ex 3 (CNS 182241)) (CD-ROM Chaparral Exhibits D023), Apr. 12, 1996.
- Brooklyn Hardware Engineering Requirements Documents, Revision 1.4 (Lavan Ex 4 (CNS 178188-211)) (CD-ROM Chaparral Exhibits D024) by Pecone, May 26, 1996.
- Brooklyn Single-Ended SCSI RAID Bridge Controller Hardware OEM Manual, Revision 2.1 (Lavan Ex 5 (CNS 177169-191)) (CD-ROM Chaparral Exhibits D025), Mar. 2, 1996.
- Coronado Hardware Engineering Requirements Document, Revision 0.0 (Lavan Ex 7 (CNS 176917-932)) (CD-ROM Chaparral Exhibits D027) by O'Dell, Sep. 30, 1996.
- ESS/FPG Organization (Lavan Ex 8 (CNS 178639-652)) (CD-ROM Chaparral Exhibits D028), Dec. 6, 1996.
- Adaptec MCS ESS Presents: Intelligent External I/O Raid Controllers "Bridge" Strategy (Lavan Ex 9 (CNS 178606-638)) (CD-ROM Chaparral Exhibits D029), Feb. 6, 1996.
- AEC-7313 Fibre Channel Daughter Board (for Brooklyn) Engineering Specification, Revision 1.0 (Lavan Ex 10 (CNS 176830-850)) (CD-ROM Chaparral Exhibits D030), Feb. 27, 1997.
- Bill of Material (Lavan Ex 14 (CNS 177211-214)) (CD-ROM Chaparral Exhibits D034), Jul. 24, 1997.
- AEC-4412B, AEC-7412/B2 External RAID Controller Hardware OEM Manual, Revision 2.0 (Lavan Ex 15 (CNS 177082-123)) (CD-ROM Chaparral Exhibits D035), Jun. 27, 1997.
- Coronado II, AEC-7312A Fibre Channel Daughter (for Brooklyn) Hardware Specification, Revision 1.2 (Lavan Ex 16 (CNS 177192-210)) (CD-ROM Chaparral Exhibits D036) by Tom Yang, Jul. 18, 1997.
- AEC-4412B, AEC7412/3B External RAID Controller Hardware OEM Manual, Revision 3.0. (Lavan Ex 17 (CNS 177124-165)) (CD-ROM Chaparral Exhibits D037), Aug. 25, 1997.
- Memo Dated Aug. 15, 1997 to AEC-7312A Evaluation Unit Customers re: B001 Release Notes (Lavan Ex 18 (CNS 182878-879)) (CD-ROM Chaparral Exhibits D038).
- Brooklyn Main Board (AES-0302) MES Schedule (Lavan Ex 19 (CNS 177759-763)) (CD-ROM Chaparral Exhibits D039), Feb. 11, 1997.
- News Release-Adaptec Adds Fibre Channel Option to its External RAID Controller Family (Lavan Ex 20 (CNS 182932-934)) (CD-ROM Chaparral Exhibits D040), May 6, 1997.
- AEC-4412B/7412B Users Guide, Rev. A (Lavan Ex 21) (CD-ROM Chaparral Exhibits D041), Jun. 19, 1995.
- Data Book- AIC-7895 PCI Bus Master Single Chip SCSI Host Adapter (Davies Ex 1 (CNS 182944-64)) (CD-ROM Chaparral Exhibits D046), May 21, 1996.

## US 7,987,311 B2

Page 5

Data Book- AIC-1160 Fibre Channel Host Adapter ASIC (Davies Ex 2 (CNS 181800-825)) (CD-ROM Chaparral Exhibits D047), Jun. 18, 1905.

Viking RAID Software (Davies Ex 3 (CNS 180969-181026)) (CD-ROM Chaparral Exhibits D048), Jun. 18, 1905.

Header File with Structure Definitions (Davies Ex 4 (CNS 180009-018)) (CD-ROM Chaparral Exhibits 0049), Aug. 8, 1996.

C++ SourceCode for the SCSI Command Handler (Davies Ex 5 (CNS 179136-168)) (CD-ROM Chaparral Exhibits D050), Aug. 8, 1996.

Header File Data Structure (Davies Ex 6 (CNS 179997-180008)) (CD-ROM Chaparral Exhibits D051), Jan. 2, 1997.

SCSI Command Handler (Davies Ex 7 (CNS 179676-719)) (CD-ROM Chaparral Exhibits D052), Jan. 2, 1997.

Coronado: Fibre Channel to SCSI Intelligent RAID Controller Product Brief (Kalwitz Ex I (CNS 182804-805)) (CD-ROM Chaparral Exhibits D053).

Bill of Material (Kalwitz Ex 2 (CNS 181632-633)) (CD-ROM Chaparral Exhibits D054), Mar. 17, 1997.

Emails Dated Jan. 13-Mar. 31, 1997 from P. Collins to Mo re: Status Reports (Kalwitz Ex 3 (CNS 182501-511)) (CD-ROM Chaparral Exhibits D055).

Hardware Schematics for the Fibre Channel Daughtercard Coronado (Kalwitz Ex 4 (CNS 181639-648)) (CD-ROM Chaparral Exhibits D056).

Adaptec Schematics re AAC-340 (Kalwitz Ex 14 CNS 177215-251)) (CD-ROM Chaparral Exhibits D057).

Bridge Product Line Review-(Manzanares Ex 3 (CNS 177307-336)) (CD-ROM Chaparral Exhibits D058).

AEC Bridge Series Products-Adaptec External Controller RAID Products Pre-Release Draft, v.6 (Manzanares Ex 4 (CNS 174632-653)) (CD-ROM Chaparral Exhibits D059), Oct. 28, 1997.

Hewlett-Packard Roseville Site Property Pass for Brian Smith (Dunning Ex 14 (HP 489)) (CD-ROM Chaparral Exhibits D078), Nov. 7, 1996.

Distribution Agreement Between Hewlett-Packard and Crossroads (Dunning Ex 15 (HP 326-33)) (CD-ROM Chaparral Exhibits D079).

HPFC-5000 Tachyon User's Manuel, First Edition (PTI 172419-839) (CD-ROM Chaparral Exhibits D084), May 1, 1996.

X3T10 994D—(Draft) Information Technology: SCSI-3 Architecture Model, Rev. 1.8 (PTI 165977) (CD-ROM Chaparral Exhibits D087).

X3T10 Project 1047D: Information Technology—SCSI-3 Controller Commands (SCC), Rev. 6c (PTI 166400-546) (CD-ROM Chaparral Exhibits D088), Sep. 3, 1996.

X3T10 995D- (Draft) SCSI-3 Primary Commands, Rev. 11 (Wanamaker Ex 5 (PTI 166050-229)) (CD-ROM Chaparral Exhibits D089), Nov. 13, 1996.

VBAR Volume Backup and Restore (CRDS 12200-202) (CD-ROM Chaparral Exhibits D099).

Preliminary Product Literature for Infinity Commstor's Fibre Channel to SCSI Protocol Bridge (Smith Ex 11; Quisenberry Ex 31 (SPL0 428-30)) (CD-ROM Chaparral Exhibits D143), Aug. 19, 1996.

Letter dated Jul. 22, 1996 from L. Petti to B. Smith re: Purchase Order for Evaluation Units from Crossroads (Smith Ex 24) CRDS 8556-57) (CD-ROM Chaparral Exhibits D144).

CrossPoint 4100 Fibre Channel to SCSI Router Preliminary Datasheet (Hulsey Ex 9 (CRDS 16129-130)) (CD-ROM Chaparral Exhibits D145), Nov. 1, 1996.

CrossPoint 4400 Fibre Channel to SCSI Router Preliminary Datasheet (Bardach Ex. 9, Quisenberry Ex 33 (CRDS 25606-607)) (CD-ROM Chaparral Exhibits D153), Nov. 1, 1996.

Fax Dated Jul. 22, 1996 from L. Petti to B. Smith re: Purchase Order from Data General for FC2S Fibre to Channel SCSI Protocol Bridge Model 11 (Smith Ex 25; Quisenberry Ex 23; Bardach Ex 11 (CRDS 8552-55; 8558)) (CD-ROM Chaparral Exhibits D155), Jul. 22, 1996.

Email Dated Dec. 20, 1996 from J. Boykin to B. Smith re: Purchase Order for Betas in February and March (Hoese Ex 16, Quisenberry Ex 25; Bardach Ex 12 (CRDS 13644-650)) (CD-ROM Chaparral Exhibits D156).

Infinity Commstor Fibre Channel Demo for Fall Comdex, 1996 (Hoese Ex 15, Bardach Ex 13 (CRDS 27415)) (CD-ROM Chaparral Exhibits D157).

Fax Dated Dec. 19, 1996 from B. Bardach to T. Rarich re: Purchase Order Information (Bardach Ex. 14; Smith Ex 16 (CRDS 4460)) (CD-ROM Chaparral Exhibits D158), Dec. 19, 1996.

Miscellaneous Documents Regarding Comdex (Quisenberry Ex 2 (CRDS 27415-465)) (CD-ROM Chaparral Exhibits D165).

CrossPoint 4100 Fibre Channel to SCSI Router Preliminary Datasheet (Quisenberry) Ex 3 (CRDS 4933-34) (CD-ROM Chaparral Exhibits D166) (CD-ROM Chaparral Exhibits D166).

CrossPoint 4400 Fibre to Channel to SCSI Router Preliminary Datasheet; Crossroads Company and Product Overview (Quisenberry Ex 4 (CRDS 25606; 16136)) (CD-ROM Chaparral Exhibits D167).

Crossroads Purchase Order Log (Quisenberry Ex 9 (CRDS 14061-062)) (CD-ROM Chaparral Exhibits D172).

RAID Manager 5 with RDAC 5 for UNIX V.4 User's Guide (LSI-01854) (CD-ROM Chaparral Exhibits P062), Sep. 1, 1996.

Letter dated May 12, 1997 from Alan G. Leal to Barbara Bardach enclosing the original OEM License and Purchase Agreement between Hewlett-Packard Company and Crossroads Systems, Inc. (CRDS 02057) (CD-ROM Chaparral Exhibits P130).

CR4x00 Product Specification (CRDS 43929) (CD-ROM Chaparral Exhibits P267), Jun. 1, 1998.

Symbios Logic—Hardware Functional Specification for the Symbios Logic Series 3 Fibre Channel Disk Array Controller Model 3701 (Engelbrecht Ex 3 (LSI-1659-1733)) (CD-ROM Pathlight Exhibits D074).

Report of the Working Group on Storage I/O for Large Scale Computing; Department of Computer Science Duke University: CS-1996-21 (PTI 173330-347). (CD-ROM Pathlight Exhibits D098).

Brian Allison's 1999 Third Quarter Sales Plan (PDX 38 ) (CNS 022120132)) (CD-ROM Pathlight Exhibits D201), Jun. 5, 2001.

Brooklyn SCSI-SCSI Intelligent External RAID Bridge Definition Phase External Documentation ((CD-ROM Pathlight Exhibits D129).

StorageWorks HSx70 System Specification by Steve Sicola dated Jun. 11, 1996 4:57pm, Revision 4.

ANSI TR X3.xxx-199x, Revision 9 of X3-991D. Draft Proposed X3 Technical Report—Small Computer System Interface—3 Generic Packetized Protocol (SCSI-GPP). Computer and Business Equipment Manufacturers Assoc.

Enterprise Systems Connection (ESON) Implementation Guide, Jul. 1996, IBM International Technical Support Organization, Poughkeepsie Center, Jul. 1, 1996.

Digital Delivers Industry-Leading Enterprise-Class Storage Solutions. StorageWorks Family Provides Easiest Path to Fibre Channel. Three pages by Company News Oncall dated Sep. 9, 2004.

American National Standard for Information Technology—Fibre Channel Protocol for SCSI. ANSI X3.269-1996, Jun. 18, 1905.

F1710A File Control Unit and F6493 Array Disk Subsystem by Hitoshi Matsushima, Shojiro Okada and Tetsuro Kudo. Feb. 3, 1995.

The Legend of AMDAHL by Jeffrey L. Rodengen (5 pages).

Office Action dated Feb. 6, 2007 from the Japanese Patent Office regarding related application No. 526873/2000. Feb. 6, 2007.

InfoServer 100 System Operation Guide, Order No. EK-DIS1K-UG-001.

iNFOSEVER 100 Installation and Owner's Guide, Order No. EK-DIS1K-IN-001.

Software Product Description: Product Name: InfoServer 100 Software, Version 1.1 SPD 38.59.00, Nov. 1, 1991.

Software Product Description: Product Name: InfoServer Client for ULTRIX, Version 1.1, SPD 40.78.01, Apr. 1, 1993.

Draft Proposed American National Standard. X3.269-199X, Revision 012. Information System—dpANS Fibre Channel Protocol fo SCSI. Dec. 4, 1995.

Impactdata Launches Breakthrough Architecture for Network Storage. Nov. 13, 1996.

Impactdata..News Release: Impactdata Introduces New Storage Architecture for High Performance Computing. 2 Pages. Nov. 12, 1996.



**US 7,987,311 B2**

Page 6

Impactdata..News Release: Impactdata's Network Peripheral Adapter (NPA) Pushes Technology Envelope of Data Storage Management in High-Speed Computing Environments. 2 Pages. Nov. 12, 1996.

Impactdata..News Release: Impactdata and Storage Concepts Announce Integration of FibreRAID II Storage Solution with Impactdata's Distributed Storage Node Architecture (DSNA). 2 pages. Nov. 18, 1996.

Impactdata..News Release: Breece Hill Libraries Now Able to Attach Directly to High Speed Networks Peripheral Adapter from Impactdata. 2 Pages. Nov. 20, 1996.

Impactdata—DSNA Questions and Answers. 22 Pages.

Impactdata—Network Storage Solutions. 4 pages.

Network Storage Building Blocks. 2 Pages.

Impactdata—NPA (Network Peripheral Interface). 4 Pages.

Impactdata—CPI (Common Peripheral Interface). 2 Pages.

Impactdata—SNC (Storage Node Controller). 2 Pages.

Impactdata—DSNA (Distributed Storage Node Architecture) Protocol. 2 Pages.

Impactdata—DS-50. 2 Pages.

Impactdata—Corporate Fact Sheet. 1 Page.

Raider-5 "Disk Array Manual for the UltraSCSI Controller". Part No. 261-0013-002. 191 Pages.

Impactdata—White Paper: Distributed Storage Node Architecture (DSNA). Jan. 1997.

Impactdata—DSNA Distributed Storage Node Architecture "Reference Guide". 44 Pages.

F1710 Logic Specification.

Translation of Final Office Action issued in JP 526873/2000 mailed May 14, 2008. 4 Pages.

Office Action issued in U.S. Appl. No. 11/851,837 dated Dec. 22, 2008, Hoese, 7 pages.

English Translation of Japanese Laid-Open Publication No. 5-181609. 9 pgs. Jul. 23, 1993.

English Translation of Japanese Laid-Open Publication No. 7-20994. 57 pgs. Jan. 24, 1995.

F1710 File Control Unit (FCU) Logical Specifications. 11 Pages, Dec. 9, 1997.

American National Standard for Information Systems: Fibre Channel—Cross-Point Switch Fabric Topology (FC-XS); X3T11/Project 959D/Rev 1.30. 114 pgs. Jun. 17, 1994.

Questioning Mailed Jun. 8, 2010 in JP Patent Application 526873/2000. 5 pages.

Office Action Mailed Aug. 17, 2010 in U.S. Appl. No. 11/947,499 to Hoese. 6 pgs.

Office Action Mailed Sep. 13, 2010 in U.S. Appl. No. 11/980,909.

Office Action Mailed Sep. 13, 2010 in U.S. Appl. No. 12/552,807.

Office Action mailed Sep. 15, 2010 in U.S. Appl. No. 12/552,885.

Office Action Mailed Sep. 23, 2010 in U.S. Appl. No. 12/552,913.

Office Action Mailed Sep. 10, 2010 in U.S. Appl. No. 12/690,592.

Office Action Mailed Dec. 2, 2010 in U.S. Appl. No. 12/910,375.

Office Action Mailed Dec. 3, 2010 in U.S. Appl. No. 12/910,431.

SCSI Applications on Fibre Channel by Robert Snively, p. 104-113, 1992.

\* cited by examiner

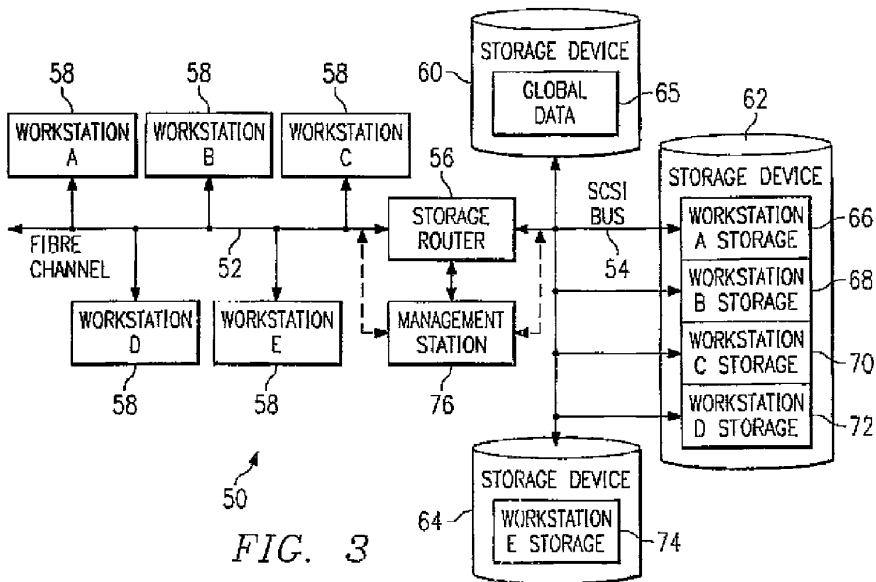
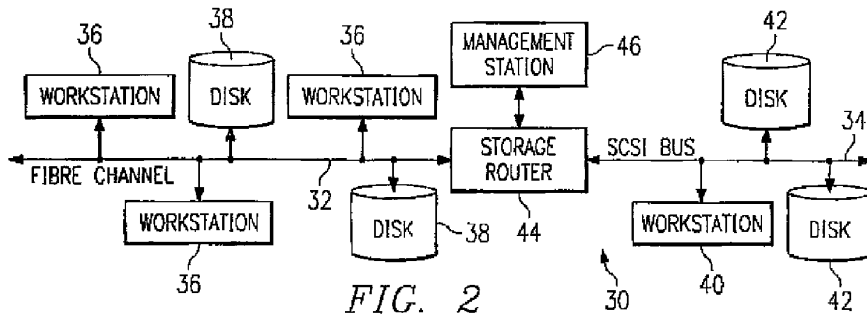
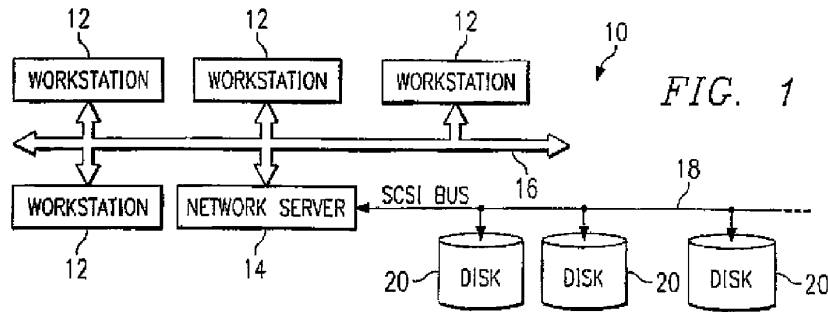

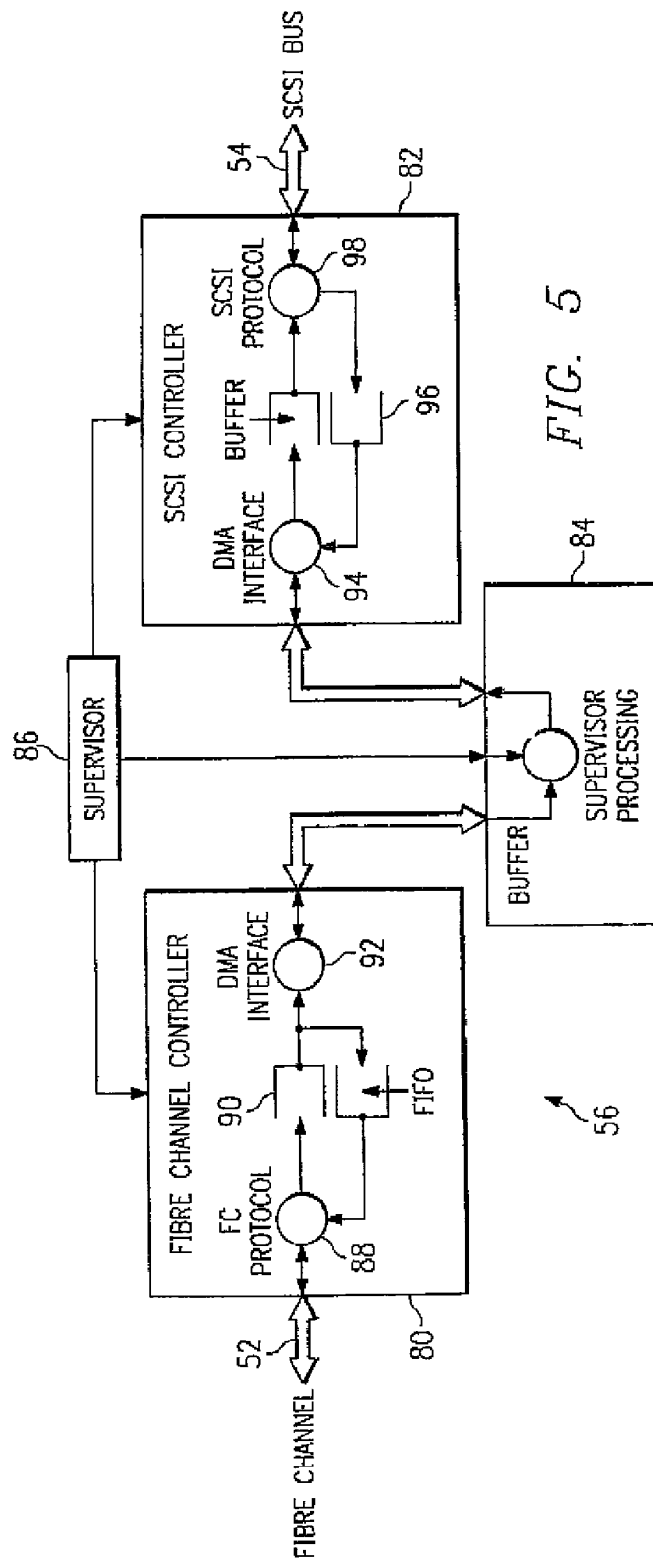
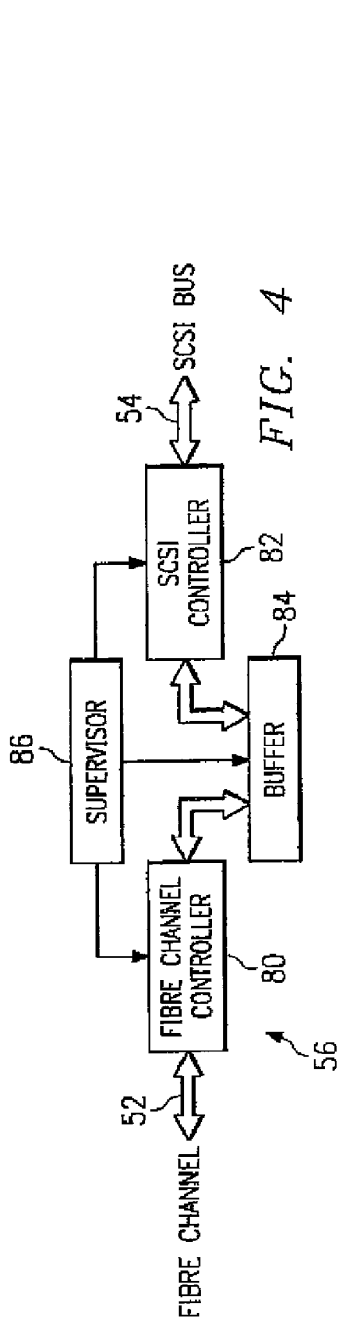



US 7,987,311 B2

1

**STORAGE ROUTER AND METHOD FOR PROVIDING VIRTUAL LOCAL STORAGE**

## RELATED APPLICATIONS

This application is a continuation of, and claims a benefit of priority under 35 U.S.C. 120 of the filing date of U.S. patent application Ser. No. 12/552,807 entitled "Storage Router and Method for Providing Virtual Local Storage" filed Sep. 2, 2009, which is a continuation of and claims the benefit of priority of U.S. patent application Ser. No. 11/851,724 entitled "Storage Router and Method for Providing Virtual Local Storage" filed Sep. 7, 2007, now U.S. Pat. No. 7,689,754 issued Mar. 30, 2010, which is a continuation of and claims the benefit of priority of U.S. patent application Ser. No. 11/442,878 entitled "Storage Router and Method for Providing Virtual Local Storage" filed, May 30, 2006, now abandoned, which is a continuation of and claims the benefit of priority of U.S. patent application Ser. No. 11/353,826 entitled "Storage Router and Method for Providing Virtual Local Storage" filed on Feb. 14, 2006, now U.S. Pat. No. 7,340,549 issued Mar. 4, 2008, which is a continuation of and claims the benefit of priority of U.S. patent application Ser. No. 10/658,163 entitled "Storage Router and Method for Providing Virtual Local Storage" filed on Sep. 9, 2003, now U.S. Pat. No. 7,051,147 issued May 23, 2006, which is a continuation of and claims the benefit of priority of U.S. patent application Ser. No. 10/081,110 by inventors Geoffrey B. Hoese and Jeffery T. Russell, entitled "Storage Router and Method for Providing Virtual Local Storage" filed on Feb. 22, 2002, now U.S. Pat. No. 6,789,152 issued on Sep. 7, 2004, which in turn is a continuation of and claims benefit of priority of U.S. application Ser. No. 09/354,682 by inventors Geoffrey B. Hoese and Jeffery T. Russell, entitled "Storage Router and Method for Providing Virtual Local Storage" filed on Jul. 15, 1999, now U.S. Pat. No. 6,421,753 issued on Jul. 16, 2002, which in turn is a continuation of and claims benefit of priority of U.S. patent application Ser. No. 09/001,799, filed on Dec. 31, 1997, now U.S. Pat. No. 5,941,972 issued on Aug. 24, 1999, and hereby incorporates these applications and patents by reference in their entireties as if they had been fully set forth herein.

## TECHNICAL FIELD OF THE INVENTION

This invention relates in general to network storage devices, and more particularly to a storage router and method for providing virtual local storage on remote SCSI storage devices to Fibre Channel devices.

## BACKGROUND OF THE INVENTION

Typical storage transport mediums provide for a relatively small number of devices to be attached over relatively short distances. One such transport medium is a Small Computer System Interface (SCSI) protocol, the structure and operation of which is generally well known as is described, for example, in the SCSI-1, SCSI-2 and SCSI-3 specifications. High speed serial interconnects provide enhanced capability to attach a large number of high speed devices to a common storage transport medium over large distances. One such serial interconnect is Fibre Channel, the structure and operation of which is described, for example, in Fibre Channel Physical and Signaling Interface (FC-PH), ANSI X3.230 Fibre Channel Arbitrated Loop (FC-AL), and ANSI X3.272 Fibre Channel Private Loop Direct Attach (FC-PLDA).

2

Conventional computing devices, such as computer workstations, generally access storage locally or through network interconnects. Local storage typically consists of a disk drive, tape drive, CD-ROM drive or other storage device contained within, or locally connected to the workstation. The workstation provides a file system structure that includes security controls, with access to the local storage device through native low level block protocols. These protocols map directly to the mechanisms used by the storage device and consist of data requests without security controls. Network interconnects typically provide access for a large number of computing devices to data storage on a remote network server. The remote network server provides file system structure, access control, and other miscellaneous capabilities that include the network interface. Access to data through the network server is through network protocols that the server must translate into low level requests to the storage device. A workstation with access to the server storage must translate its file system protocols into network protocols that are used to communicate with the server. Consequently, from the perspective of a workstation, or other computing device, seeking to access such server data, the access is much slower than access to data on a local storage device.

## SUMMARY OF THE INVENTION

In accordance with the present invention, a storage router and method for providing virtual local storage on remote SCSI storage devices to Fibre Channel devices are disclosed that provide advantages over conventional network storage devices and methods.

According to one aspect of the present invention, a storage router and storage network provide virtual local storage on remote SCSI storage devices to Fibre Channel devices. A plurality of Fibre Channel devices, such as workstations, are connected to a Fibre Channel transport medium, and a plurality of SCSI storage devices are connected to a SCSI bus transport medium. The storage router interfaces between the Fibre Channel transport medium and the SCSI bus transport medium. The storage router maps between the workstations and the SCSI storage devices and implements access controls for storage space on the SCSI storage devices. The storage router then allows access from the workstations to the SCSI storage devices using native low level, block protocol in accordance with the mapping and the access controls.

According to another aspect of the present invention, virtual local storage on remote SCSI storage devices is provided to Fibre Channel devices. A Fibre Channel transport medium and a SCSI bus transport medium are interfaced with. A configuration is maintained for SCSI storage devices connected to the SCSI bus transport medium. The configuration maps between Fibre Channel devices and the SCSI storage devices and implements access controls for storage space on the SCSI storage devices. Access is then allowed from Fibre Channel initiator devices to SCSI storage devices using native low level, block protocol in accordance with the configuration.

A technical advantage of the present invention is the ability to centralize local storage for networked workstations without any cost of speed or overhead. Each workstation accesses its virtual local storage as if it were locally connected. Further, the centralized storage devices can be located in a significantly remote position even in excess of ten kilometers as defined by Fibre Channel standards.

Another technical advantage of the present invention is the ability to centrally control and administer storage space for connected users without limiting the speed with which the

US 7,987,311 B2

3

users can access local data. In addition, global access to data, backups, virus scanning and redundancy can be more easily accomplished by centrally located storage devices.

A further technical advantage of the present invention is providing support for SCSI storage devices as local storage for Fibre Channel hosts. In addition, the present invention helps to provide extended capabilities for Fibre Channel and for management of storage subsystems.

#### BRIEF DESCRIPTION OF THE DRAWINGS

A more complete understanding of the present invention and the advantages thereof may be acquired by referring to the following description taken in conjunction with the accompanying drawings, in which like reference numbers indicate like features, and wherein:

FIG. 1 is a block diagram of a conventional network that provides storage through a network server;

FIG. 2 is a block diagram of one embodiment of a storage network with a storage router that provides global access and routing;

FIG. 3 is a block diagram of one embodiment of a storage network with a storage router that provides virtual local storage;

FIG. 4 is a block diagram of one embodiment of the storage router of FIG. 3; and

FIG. 5 is a block diagram of one embodiment of data flow within the storage router of FIG. 4.

#### DETAILED DESCRIPTION OF THE INVENTION

FIG. 1 is a block diagram of a conventional network, indicated generally at 10, that provides access to storage through a network server. As shown, network 10 includes a plurality of workstations 12 interconnected with a network server 14 via a network transport medium 16. Each workstation 12 can generally comprise a processor, memory, input/output devices, storage devices and a network adapter as well as other common computer components. Network server 14 uses a SCSI bus 18 as a storage transport medium to interconnect with a plurality of storage devices 20 (tape drives, disk drives, etc.). In the embodiment of FIG. 1, network transport medium 16 is a network connection and storage devices 20 comprise hard disk drives, although there are numerous alternate transport mediums and storage devices.

In network 10, each workstation 12 has access to its local storage device as well as network access to data on storage devices 20. The access to a local storage device is typically through native low level, block protocols. On the other hand, access by a workstation 12 to storage devices 20 requires the participation of network server 14 which implements a file system and transfers data to workstations 12 only through high level file system protocols. Only network server 14 communicates with storage devices 20 via native low level, block protocols. Consequently, the network access by workstations 12 through network server 14 is slow with respect to their access to local storage. In network 10, it can also be a logistical problem to centrally manage and administer local data distributed across an organization, including accomplishing tasks such as backups, virus scanning and redundancy.

FIG. 2 is a block diagram of one embodiment of a storage network, indicated generally at 30, with a storage router that provides global access and routing. This environment is significantly different from that of FIG. 1 in that there is no network server involved. In FIG. 2, a Fibre Channel high speed serial transport 32 interconnects a plurality of workstations 36 and storage devices 38. A SCSI bus storage transport

4

medium interconnects workstations 40 and storage devices 42. A storage router 44 then serves to interconnect these mediums and provide devices on either medium global, transparent access to devices on the other medium. Storage router 44 routes requests from initiator devices on one medium to target devices on the other medium and routes data between the target and the initiator. Storage router 44 can allow initiators and targets to be on either side. In this manner, storage router 44 enhances the functionality of Fibre Channel 32, by providing access, for example, to legacy SCSI storage devices on SCSI bus 34. In the embodiment of FIG. 2, the operation of storage router 44 can be managed by a management station 46 connected to the storage router via a direct serial connection.

In storage network 30, any workstation 36 or workstation 40 can access any storage device 38 or storage device 42 through native low level, block protocols, and vice versa. This functionality is enabled by storage router 44 which routes requests and data as a generic transport between Fibre Channel 32 and SCSI bus 34. Storage router 44 uses tables to map devices from one medium to the other and distributes requests and data across Fibre Channel 32 and SCSI bus 34 without any security access controls. Although this extension of the high speed serial interconnect provided by Fibre Channel is beneficial, it is desirable to provide security controls in addition to extended access to storage devices through a native low level, block protocol.

FIG. 3 is a block diagram of one embodiment of a storage network, indicated generally at 50, with a storage router that provides virtual local storage. Similar to that of FIG. 2, storage network 50 includes a Fibre Channel high speed serial interconnect 52 and a SCSI bus 54 bridged by a storage router 56. Storage router 56 of FIG. 3 provides for a large number of workstations 58 to be interconnected on a common storage transport and to access common storage devices 60, 62 and 64 through native low level, block protocols.

According to the present invention, storage router 56 has enhanced functionality to implement security controls and routing such that each workstation 58 can have access to a specific subset of the overall data stored in storage devices 60, 62 and 64. This specific subset of data has the appearance and characteristics of local storage and is referred to herein as virtual local storage. Storage router 56 allows the configuration and modification of the storage allocated to each attached workstation 58 through the use of mapping tables or other mapping techniques.

As shown in FIG. 3, for example, storage device 60 can be configured to provide global data 65 which can be accessed by all workstations 58. Storage device 62 can be configured to provide partitioned subsets 66, 68, 70 and 72, where each partition is allocated to one of the workstations 58 (workstations A, B, C and D). These subsets 66, 68, 70 and 72 can only be accessed by the associated workstation 58 and appear to the associated workstation 58 as local storage accessed using native low level, block protocols. Similarly, storage device 64 can be allocated as storage for the remaining workstation 58 (workstation E).

Storage router 56 combines access control with routing such that each workstation 58 has controlled access to only the specified partition of storage device 62 which forms virtual local storage for the workstation 58. This access control allows security control for the specified data partitions. Storage router 56 allows this allocation of storage devices 60, 62 and 64 to be managed by a management station 76. Management station 76 can connect directly to storage router 56 via a direct connection or, alternately, can interface with storage router 56 through either Fibre Channel 52 or SCSI bus 54. In the latter case, management station 76 can be a workstation or

US 7,987,311 B2

5

other computing device with special rights such that storage router 56 allows access to mapping tables and shows storage devices 60, 62 and 64 as they exist physically rather than as they have been allocated.

The environment of FIG. 3 extends the concept of single workstation having locally connected storage devices to a storage network 50 in which workstations 58 are provided virtual local storage in a manner transparent to workstations 58. Storage router 56 provides centralized control of what each workstation 58 sees as its local drive, as well as what data it sees as global data accessible by other workstations 58. Consequently, the storage space considered by the workstation 58 to be its local storage is actually a partition (i.e., logical storage definition) of a physically remote storage device 60, 62 or 64 connected through storage router 56. This means that similar requests from workstations 58 for access to their local storage devices produce different accesses to the storage space on storage devices 60, 62 and 64. Further, no access from a workstation 58 is allowed to the virtual local storage of another workstation 58.

The collective storage provided by storage devices 60, 62 and 64 can have blocks allocated by programming means within storage router 56. To accomplish this function, storage router 56 can include routing tables and security controls that define storage allocation for each workstation 58. The advantages provided by implementing virtual local storage in centralized storage devices include the ability to do collective backups and other collective administrative functions more easily. This is accomplished without limiting the performance of workstations 58 because storage access involves native low level, block protocols and does not involve the overhead of high level protocols and file systems required by network servers.

FIG. 4 is a block diagram of one embodiment of storage router 56 of FIG. 3. Storage router 56 can comprise a Fibre Channel controller 80 that interfaces with Fibre Channel 52 and a SCSI controller 82 that interfaces with SCSI bus 54. A buffer 84 provides memory work space and is connected to both Fibre Channel controller 80 and to SCSI controller 82. A supervisor unit 86 is connected to Fibre Channel controller 80, SCSI controller 82 and buffer 84. Supervisor unit 86 comprises a microprocessor for controlling operation of storage router 56 and to handle mapping and security access for requests between Fibre Channel 52 and SCSI bus 54.

FIG. 5 is a block diagram of one embodiment of data flow within storage router 56 of FIG. 4. As shown, data from Fibre Channel 52 is processed by a Fibre Channel (FC) protocol unit 88 and placed in a FIFO queue 90. A direct memory access (DMA) interface 92 then takes data out of FIFO queue 90 and places it in buffer 84. Supervisor unit 86 processes the data in buffer 84 as represented by supervisor processing 93. This processing involves mapping between Fibre Channel 52 and SCSI bus 54 and applying access controls and routing functions. A DMA interface 94 then pulls data from buffer 84 and places it into a buffer 96. A SCSI protocol unit 98 pulls data from buffer 96 and communicates the data on SCSI bus 54. Data flow in the reverse direction, from SCSI bus 54 to Fibre Channel 52, is accomplished in a reverse manner.

The storage router of the present invention is a bridge device that connects a Fibre Channel link directly to a SCSI bus and enables the exchange of SCSI command set information between application clients on SCSI bus devices and the Fibre Channel links. Further, the storage router applies access controls such that virtual local storage can be established in remote SCSI storage devices for workstations on the Fibre Channel link. In one embodiment, the storage router provides a connection for Fibre Channel links running the SCSI Fibre

6

Channel Protocol (FCP) to legacy SCSI devices attached to a SCSI bus. The Fibre Channel topology is typically an Arbitrated Loop (FC\_AL).

In part, the storage router enables a migration path Fibre Channel based, serial SCSI networks by providing connectivity for legacy SCSI bus devices. The storage router can be attached to a Fibre Channel Arbitrated Loop and a SCSI bus to support a number of SCSI devices. Using configuration settings, the storage router can make the SCSI bus devices available on the Fibre Channel network as FCP logical units. Once the configuration is defined, operation of the storage router is transparent to application clients. In this manner, the storage router can form an integral part of the migration to new Fibre Channel based networks while providing a means to continue using legacy SCSI devices.

In one implementation (not shown), the storage router can be a rack mount or free standing device with an internal power supply. The storage router can have a Fibre Channel and SCSI port, and a standard, detachable power cord can be used, the FC connector can be a copper DB9 connector, and the SCSI connector can be a 68-pin type. Additional modular jacks can be provided for a serial port and an 802.3 10BaseT port, i.e. twisted pair Ethernet, for management access. The SCSI port of the storage router can support SCSI direct and sequential access target devices and can support SCSI initiators, as well. The Fibre Channel port can interface to SCSI-3 FCP enabled devices and initiators.

To accomplish its functionality, one implementation of the storage router uses: a Fibre Channel interface based on the HEWLETT-PACKARD TACHYON HPFC-5000 controller and a GLM media interface; an Intel 80960RP processor, incorporating independent data and program memory spaces, and associated logic required to implement a stand alone processing system; and a serial port for debug and system configuration. Further, this implementation includes a SCSI interface supporting Fast-20 based on the SYMBIOS 53C8xx series SCSI controllers, and an operating system based upon the WIND RIVERS SYSTEMS VXWORKS or IXWORKS kernel, as determined by design. In addition, the storage router includes software as required to control basic functions of the various elements, and to provide appropriate translations between the FC and SCSI protocols.

The storage router has various modes of operation that are possible between FC and SCSI target and initiator combinations. These modes are: FC Initiator to SCSI Target; SCSI Initiator to FC Target; SCSI Initiator to SCSI Target; and FC Initiator to FC Target. The first two modes can be supported concurrently in a single storage router device and are discussed briefly below. The third mode can involve two storage router devices back to back and can serve primarily as a device to extend the physical distance beyond that possible via a direct SCSI connection. The last mode can be used to carry FC protocols encapsulated on other transmission technologies (e.g. ATM, SONET), or to act as a bridge between two FC loops (e.g. as a two port fabric).

The FC Initiator to SCSI Target mode provides for the basic configuration of a server using Fibre Channel to communicate with SCSI targets. This mode requires that a host system have an FC attached device and associated device drivers and software to generate SCSI-3 FCP requests. This system acts as an initiator using the storage router to communicate with SCSI target devices. The SCSI devices supported can include SCSI-2 compliant direct or sequential access (disk or tape) devices. The storage router serves to translate command and status information and transfer data between SCSI-3 FCP and SCSI-2, allowing the use of standard SCSI-2 devices in a Fibre Channel environment.



US 7,987,311 B2

7

The SCSI Initiator to FC Target mode provides for the configuration of a server using SCSI-2 to communicate with Fibre Channel targets. This mode requires that a host system has a SCSI-2 interface and driver software to control SCSI-2 target devices. The storage router will connect to the SCSI-2 bus and respond as a target to multiple target IDs. Configuration information is required to identify the target IDs to which the bridge will respond on the SCSI-2 bus. The storage router then translates the SCSI-2 requests to SCSI-3 FCP requests, allowing the use of FC devices with a SCSI host system. This will also allow features such as a tape device acting as an initiator on the SCSI bus to provide full support for this type of SCSI device.

In general, user configuration of the storage router will be needed to support various functional modes of operation. Configuration can be modified, for example, through a serial port or through an Ethernet port via SNMP (simple network management protocol) or the Telnet session. Specifically, SNMP manageability can be provided via a B02.3 Ethernet interface. This can provide for configuration changes as well as providing statistics and error information. Configuration can also be performed via TELNET or RS-232 interfaces with menu driven command interfaces. Configuration information can be stored in a segment of flash memory and can be retained across resets and power off cycles. Password protection can also be provided.

In the first two modes of operation, addressing information is needed to map from FC addressing to SCSI addressing and vice versa. This can be 'hard' configuration data, due to the need for address information to be maintained across initialization and partial reconfigurations of the Fibre Channel address space. In an arbitrated loop configuration, user configured addresses will be needed for AL\_PAs in order to insure that known addresses are provided between loop reconfigurations.

With respect to addressing, FCP and SCSI 2 systems employ different methods of addressing target devices. Additionally, the inclusion of a storage router means that a method of translating device IDs needs to be implemented. In addition, the storage router can respond to commands without passing the commands through to the opposite interface. This can be implemented to allow all generic FCP and SCSI commands to pass through the storage router to address attached devices, but allow for configuration and diagnostics to be performed directly on the storage router through the FC and SCSI interfaces.

Management commands are those intended to be processed by the storage router controller directly. This may include diagnostic, mode, and log commands as well as other vendor-specific commands. These commands can be received and processed by both the FOP and SCSI interfaces, but are not typically bridged to the opposite interface. These commands may also have side effects on the operation of the storage router, and cause other storage router operations to change or terminate.

A primary method of addressing management commands through the FCP and SCSI interfaces can be through peripheral device type addressing. For example, the storage router can respond to all operations addressed to logical unit (LUN) zero as a controller device. Commands that the storage router will support can include INQUIRY as well as vendor-specific management commands. These are to be generally consistent with SCC standard commands.

The SCSI bus is capable of establishing bus connections between targets. These targets may internally address logical units. Thus, the prioritized addressing scheme used by SCSI subsystems can be represented as follows: BUS:TARGET:

8

LOGICAL UNIT. The BUS identification is intrinsic in the configuration, as a SCSI initiator is attached to only one bus. Target addressing is handled by bus arbitration from information provided to the arbitrating device. Target addresses are assigned to SCSI devices directly through some means of configuration, such as a hardware jumper, switch setting, or device specific software configuration. As such, the SCSI protocol provides only logical unit addressing within the Identify message. Bus and target information is implied by the established connection.

Fibre Channel devices within a fabric are addressed by a unique port identifier. This identifier is assigned to a port during certain well-defined states of the FC protocol. Individual ports are allowed to arbitrate for a known, user defined address. If such an address is not provided, or if arbitration for a particular-user address fails, the port is assigned a unique address by the FC protocol. This address is generally not guaranteed to be unique between instances. Various scenarios exist where the AL-PA of a device will change, either after power cycle or loop reconfiguration.

The FC protocol also provides a logical unit address field within command structures to provide addressing to devices internal to a port. The FCP\_CMD payload specifies an eight byte LUN field. Subsequent identification of the exchange between devices is provided by the FQXID (Fully Qualified Exchange ID).

FC ports can be required to have specific addresses assigned. Although basic functionality is not dependent on this, changes in the loop configuration could result in disk targets changing identifiers with the potential risk of data corruption or loss. This configuration can be straightforward, and can consist of providing the device a loop-unique ID (AL\_PA) in the range of "01h" to "EFh." Storage routers could be shipped with a default value with the assumption that most configurations will be using single storage routers and no other devices requesting the present ID. This would provide a minimum amount of initial configuration to the system administrator. Alternately, storage routers could be defaulted to assume any address so that configurations requiring multiple storage routers on a loop would not require that the administrator assign a unique ID to the additional storage routers.

Address translation is needed where commands are issued in the cases FC Initiator to SCSI Target and SCSI Initiator to FC Target. Target responses are qualified by the FQXID and will retain the translation acquired at the beginning of the exchange. This prevents configuration changes occurring during the course of execution of a command from causing data or state information to be inadvertently misdirected. Configuration can be required in cases of SCSI Initiator to FC Target, as discovery may not effectively allow for FCP targets to consistently be found. This is due to an FC arbitrated loop supporting addressing of a larger number of devices than a SCSI bus and the possibility of FC devices changing their AL-PA due to device insertion or other loop initialization.

In the direct method, the translation to BUS:TARGET: LUN of the SCSI address information will be direct. That is, the values represented in the FCP LUN field will directly map to the values in effect on the SCSI bus. This provides a clean translation and does not require SCSI bus discovery. It also allows devices to be dynamically added to the SCSI bus without modifying the address map. It may not allow for complete discovery by FCP initiator devices, as gaps between device addresses may halt the discovery process. Legacy SCSI device drivers typically halt discovery on a target device at the first unoccupied LUN, and proceed to the next target.

US 7,987,311 B2

9

This would lead to some devices not being discovered. However, this allows for hot plugged devices and other changes to the loop addressing.

In the ordered method, ordered translation requires that the storage router perform discovery on reset, and collapses the addresses on the SCSI bus to sequential FSP LUN values. Thus, the FCP LUN values 0-N can represent N+1 SCSI devices, regardless of SCSI address values, in the order in which they are isolated during the SCSI discovery process. This would allow the FCP initiator discovery process to identify all mapped SCSI devices without further configuration. This has the limitation that hot-plugged devices will not be identified until the next reset cycle. In this case, the address may also be altered as well.

In addition to addressing, according to the present invention, the storage router provides configuration and access controls that cause certain requests from FC Initiators to be directed to assigned virtual local storage partitioned on SCSI storage devices. For example, the same request for LUN 0 (local storage) by two different FC Initiators can be directed to two separate subsets of storage. The storage router can use tables to map, for each initiator, what storage access is available and what partition is being addressed by a particular request. In this manner, the storage space provided by SCSI storage devices can be allocated to FC initiators to provide virtual local storage as well as to create any other desired configuration for secured access.

Although the present invention has been described in detail, it should be understood that various changes, substitutions, and alterations can be made hereto without departing from the spirit and scope of the invention as defined by the appended claims.

What is claimed is:

1. A storage router for providing virtual local storage on remote storage devices, comprising:

a first controller operable to connect to a first transport medium, wherein the first medium is a serial transport medium;

a second controller operable to connect to a second transport medium; and

a processing device coupled to the first controller, wherein the processing device is configured to:

maintain a map to allocate storage space on the remote storage devices to devices connected to the first transport medium by associating representations of the devices connected to the first transport medium with representations of storage space on the remote storage devices, wherein each representation of a device connected to the first transport medium is associated with one or more representations of storage space on the remote storage devices;

control access from the devices connected to the first transport medium to the storage space on the remote storage devices in accordance with the map and using native low level block protocol, further comprising:

for a device connected to the first transport medium, identifying LUNs for storage space allocated to that device in the map;

presenting to that device only the identified LUNs as available storage space; and

processing native low level block requests directed to the identified LUNs from that device to allow access to the storage space associated with the identified LUNs.

2. The storage router of claim 1, wherein the storage router is further operable to, present the identified LUNs in response to a native low level block protocol discovery request.

10

3. The storage router of claim 2, wherein the storage router identifies the LUNs in response to the discovery request.

4. The storage router of claim 1, wherein the map resides at the storage router and is maintained at the storage router.

5. The storage router of claim 1, wherein the storage router is configured to receive requests according to a first low level block protocol from the device connected to the first transport medium and forward commands according to a second low level block protocol to the remote storage devices.

6. The storage router of claim 1, wherein the map comprises one or more tables.

7. The storage router of claim 1, wherein the virtual local storage is provided to the devices connected to the first transport medium in a manner that is transparent to the devices and wherein the storage space allocated to the devices connected to the first transport medium appears to the devices as local storage.

8. The storage router of claim 1, wherein the storage router provides centralized control of what the devices connected to the first transport medium see as local storage.

9. The storage router of claim 1, wherein the storage router is operable to route requests to the same LUN from different devices connected to the first transport medium to different subsets of storage space on the remote storage devices.

10. The storage router of claim 1, wherein the representations of devices connected to the first transport medium are unique identifiers.

11. The storage router of claim 10, wherein the unique identifiers are world wide names.

12. The storage router of claim 1, wherein the storage router is configured to allow modification of the map in a manner transparent to and without involvement of the devices connected to the first transport medium.

13. The storage router of claim 1, wherein the processing device is a microprocessor.

14. The storage router of claim 1, wherein the processing device is a microprocessor and associated logic to implement a stand-alone processing system.

15. The storage router of claim 1, wherein the storage router is operable to communicate with devices connected to the first transport medium via Ethernet.

16. A method for providing virtual local storage on remote storage devices comprising:

connecting a storage router between a set of devices connected to a first transport medium and a set of remote storage devices, wherein the first transport medium is a serial transport medium;

maintaining a map at the storage router to allocate storage space on the remote storage devices to devices connected to the first transport medium by associating representations of the devices connected to the first transport medium with representations of storage space on the remote storage devices, wherein each representation of a device connected to the first transport medium is associated with one or more representations of storage space on the remote storage devices;

controlling access from the devices connected to the first transport medium to the storage space on the remote storage devices in accordance with the map by:

for a device connected to the first transport medium, identifying LUNs for storage space allocated to that device in the map;

presenting to that device only the identified LUNs as available storage space; and

processing native low level block requests directed to the identified LUNs from that device to allow access to the storage space associated with the identified LUNs.

US 7,987,311 B2

11

17. The method of claim 16, further comprising presenting the identified LUNs in response to a native low level block protocol discovery request.

18. The method of claim 16, further comprising identifying the LUNs in response to the discovery request.

19. The method of claim 16, wherein the map associates a representation of a device connected to the first transport medium with a representation of an entire storage space of at least one remote storage device.

20. The method of claim 16, wherein the map resides at the storage router and is maintained at the storage router.

21. The method of claim 16, further comprising receiving commands at the storage router according to a first low level block protocol from the device connected to the first transport medium and forwarding commands according to a second low level block protocol to the remote storage devices.

22. The method of claim 16, wherein the map comprises one or more tables.

23. The method of claim 16, wherein the virtual local storage is provided to the devices connected to the first transport medium in a manner that is transparent to the devices and

12

wherein the storage space allocated to the devices connected to the first transport medium appears to the devices as local storage.

24. The method of claim 16, wherein the storage router provides centralized control of what the devices connected to the first transport medium see as local storage.

25. The method of claim 16, wherein the storage router is operable to route requests to the same LUN from different devices connected to the first transport medium to different subsets of storage space on the remote storage devices.

26. The method of claim 16, wherein the representations of devices connected to the first transport medium are unique identifiers.

27. The method of claim 26, wherein the unique identifiers are world wide names.

28. The method of claim 16, wherein the storage router is configured to allow modification of the map in a manner transparent to and without involvement of the devices connected to the first transport medium.

\* \* \* \* \*