



## U.S. PATENT DOCUMENTS

4,672,816	6/1987	Takahashi .....	62/180	4,845,418	7/1989	Conner .....	318/778
4,682,473	7/1987	Rogers, III .....	62/89	4,860,231	8/1989	Ballard et al. ....	364/571
4,688,547	8/1987	Ballard et al. ....	126/116 A	4,860,552	8/1989	Beckey .....	62/158
4,710,691	12/1987	Bergstrom et al. ....	318/696	4,868,467	9/1989	Davis .....	318/254
4,712,050	12/1987	Nagasawa et al. ....	318/254	4,872,123	10/1989	Morita .....	364/571
4,722,018	1/1988	Pohl .....	361/29	4,879,502	11/1989	Endo et al. ....	318/808
4,736,143	4/1988	Nakamura et al. ....	318/432	4,902,952	2/1990	Lavery .....	318/645
4,743,815	5/1988	Gee et al. ....	318/254	4,939,437	7/1990	Farag et al. ....	318/473
4,763,425	8/1988	Grennan .....	34/48	4,941,325	7/1990	Nuding .....	62/158
4,773,587	9/1988	Lipman .....	236/11	4,950,918	8/1990	O'Breartuin et al. ....	307/242
4,806,833	2/1989	Young .....	318/335	4,992,715	2/1991	Nakamura et al. ....	318/432 X
4,829,221	5/1989	Grunberg et al. ....	318/587	5,107,685	4/1992	Kobayashi .....	318/807
				5,119,071	6/1992	Takezawa .....	318/811
				5,129,234	7/1992	Alford .....	62/176.6
				5,197,375	3/1993	Rosenbrock et al. ..	364/557

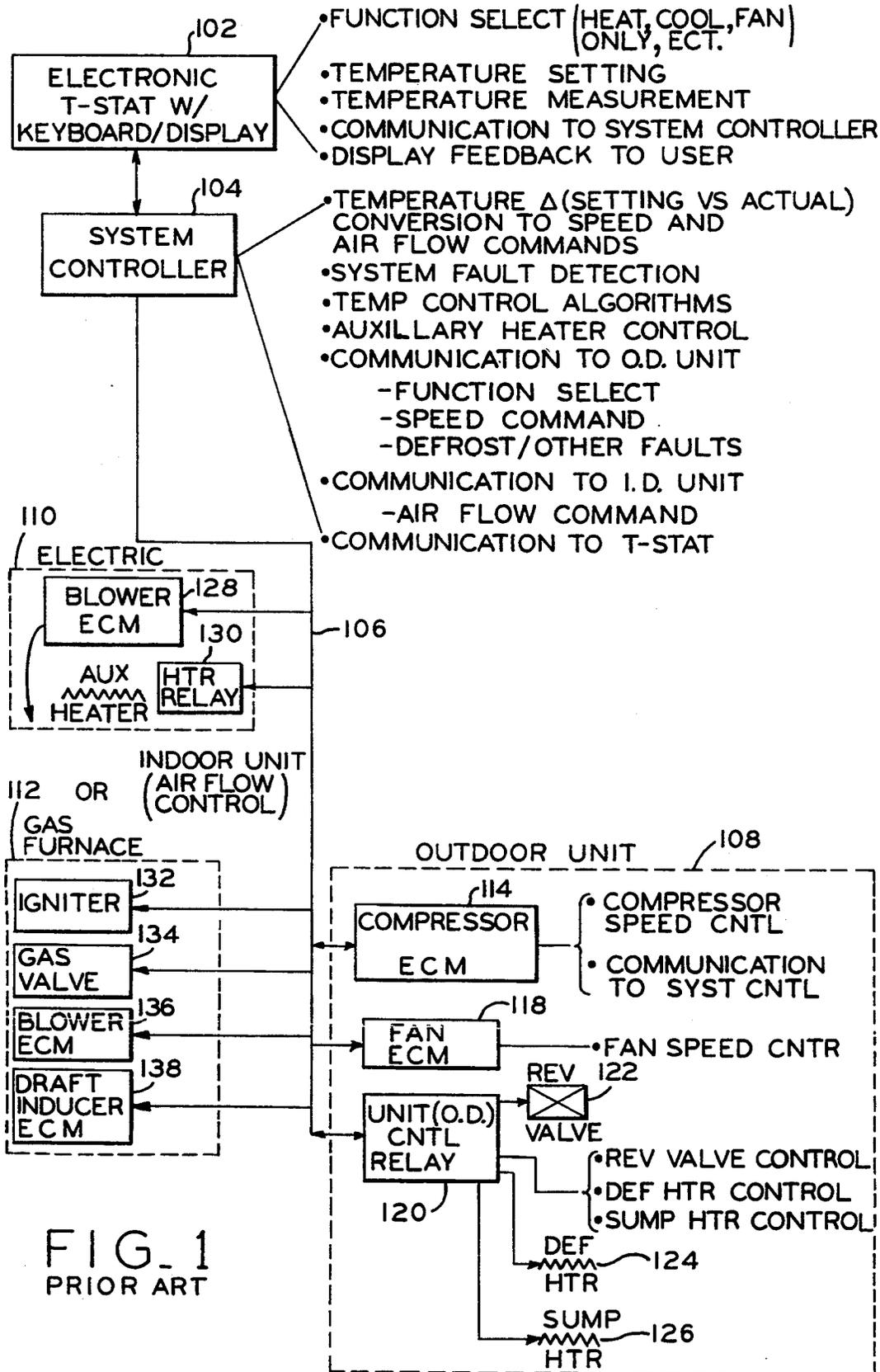
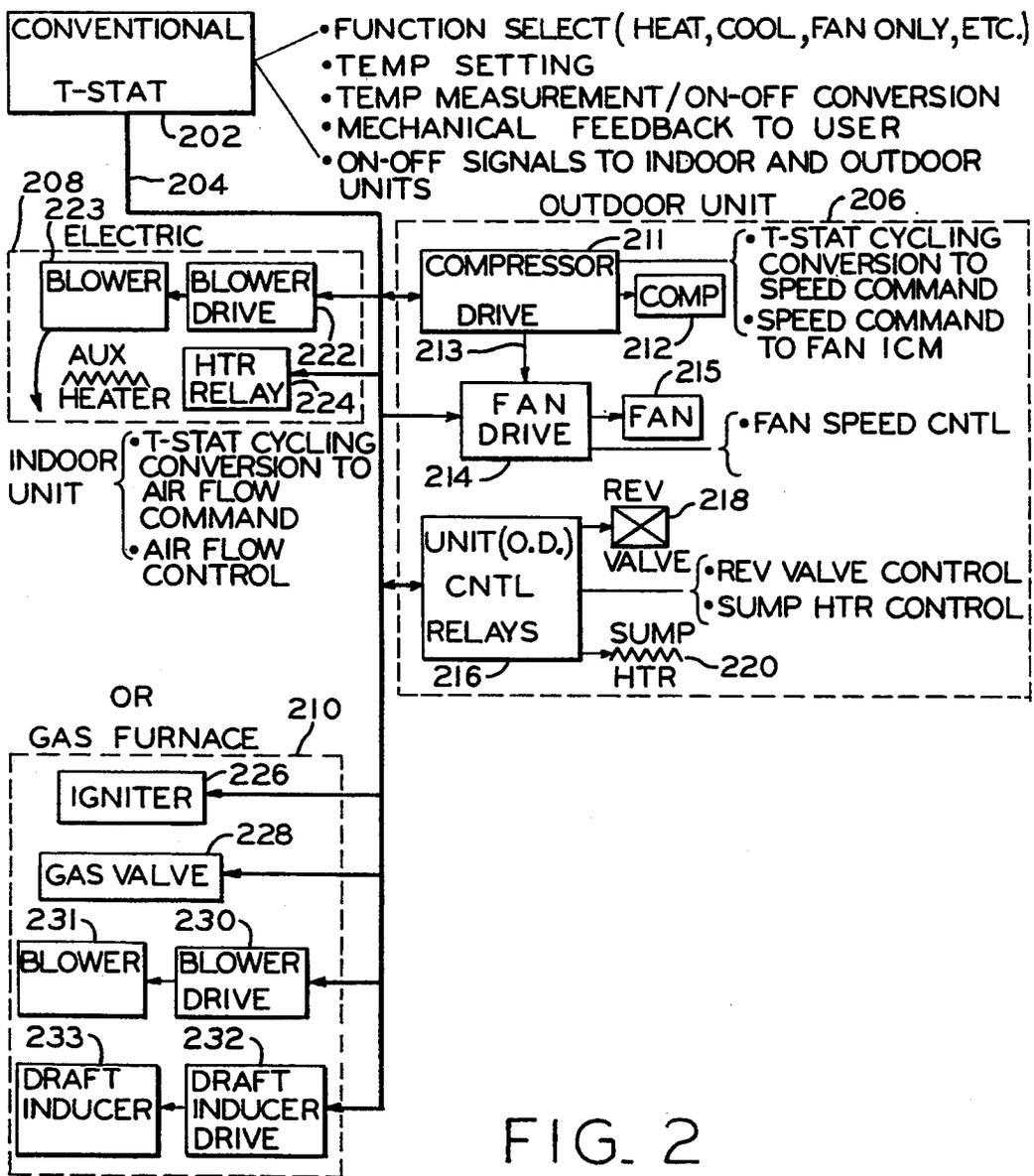

FIG. 1  
PRIOR ART



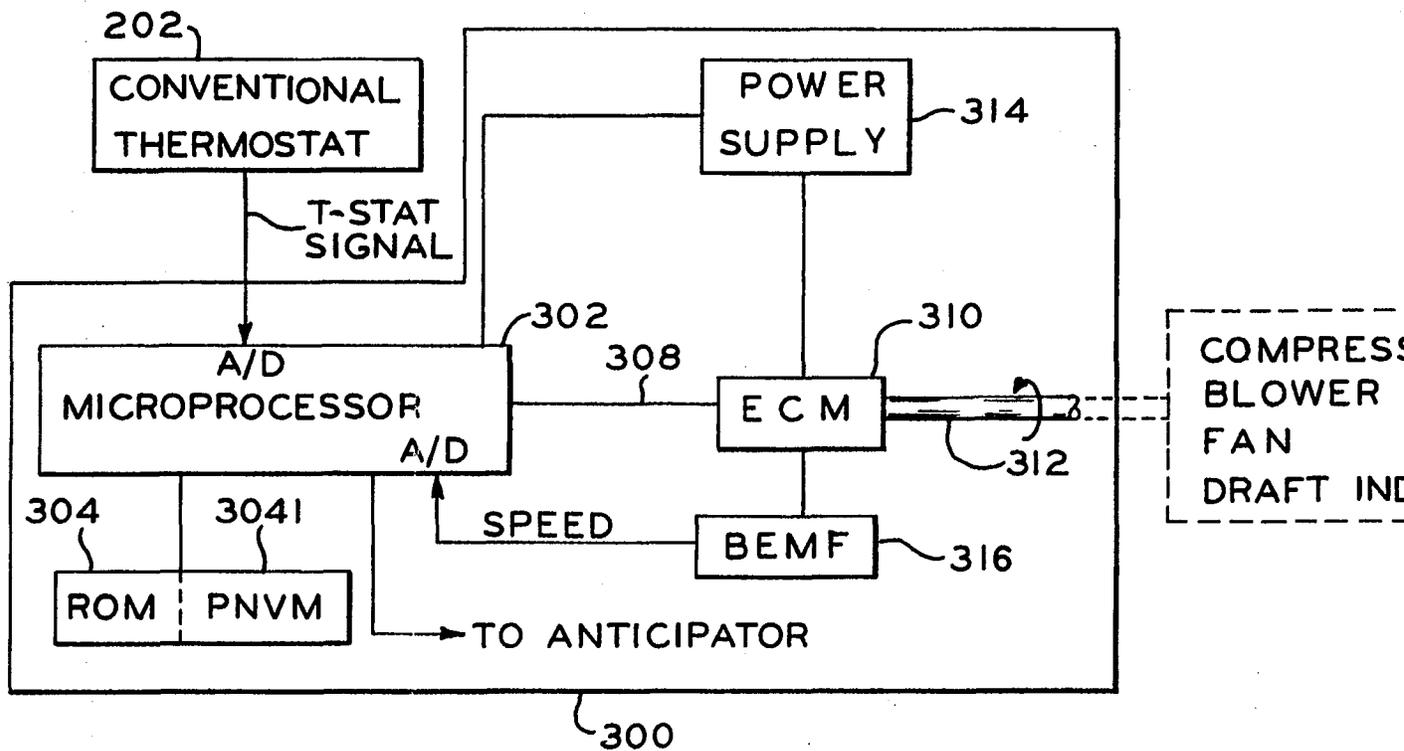

FIG. 3

# Explore Litigation Insights

Docket Alarm provides insights to develop a more informed litigation strategy and the peace of mind of knowing you're on top of things.

## Real-Time Litigation Alerts



Keep your litigation team up-to-date with **real-time alerts** and advanced team management tools built for the enterprise, all while greatly reducing PACER spend.

Our comprehensive service means we can handle Federal, State, and Administrative courts across the country.

## Advanced Docket Research



With over 230 million records, Docket Alarm's cloud-native docket research platform finds what other services can't. Coverage includes Federal, State, plus PTAB, TTAB, ITC and NLRB decisions, all in one place.

Identify arguments that have been successful in the past with full text, pinpoint searching. Link to case law cited within any court document via Fastcase.

## Analytics At Your Fingertips



Learn what happened the last time a particular judge, opposing counsel or company faced cases similar to yours.

Advanced out-of-the-box PTAB and TTAB analytics are always at your fingertips.

## API

Docket Alarm offers a powerful API (application programming interface) to developers that want to integrate case filings into their apps.

## LAW FIRMS

Build custom dashboards for your attorneys and clients with live data direct from the court.

Automate many repetitive legal tasks like conflict checks, document management, and marketing.

## FINANCIAL INSTITUTIONS

Litigation and bankruptcy checks for companies and debtors.

## E-DISCOVERY AND LEGAL VENDORS

Sync your system to PACER to automate legal marketing.