



(12) **United States Patent**
Marcinkiewicz et al.

(10) **Patent No.:** **US 7,342,379 B2**
(45) **Date of Patent:** **Mar. 11, 2008**

(54) **SENSORLESS CONTROL SYSTEMS AND METHODS FOR PERMANENT MAGNET ROTATING MACHINES**

5,006,774 A 4/1991 Rees
5,173,650 A 12/1992 Hedlund
5,220,264 A 6/1993 Yamada
5,311,435 A * 5/1994 Yocum et al. 701/226
5,447,414 A 9/1995 Nordby et al.
5,457,375 A 10/1995 Marcinkiewicz et al.

(75) Inventors: **Joseph G. Marcinkiewicz**, St. Peters, MO (US); **Prakash B. Shahi**, St. Louis, MO (US); **Michael I. Henderson**, North Yorkshire (GB)

(73) Assignee: **Emerson Electric Co.**, St. Louis, MO (US)

(Continued)

(*) Notice: Subject to any disclaimer, the term of this patent is extended or adjusted under 35 U.S.C. 154(b) by 137 days.

“High Performance Sensorless Solutions For Induction Motor Control”, V. Bostan, M. Cuibus and C. Ilas; pp. 1-9; prior to Jun. 24, 2005.

(21) Appl. No.: **11/293,744**

(Continued)

(22) Filed: **Dec. 2, 2005**

Primary Examiner—Karen Masih
(74) *Attorney, Agent, or Firm*—Harness, Dickey & Pierce, P.L.C.

(65) **Prior Publication Data**

US 2006/0290302 A1 Dec. 28, 2006

(57) **ABSTRACT**

Related U.S. Application Data

(60) Provisional application No. 60/694,077, filed on Jun. 24, 2005, provisional application No. 60/694,066, filed on Jun. 24, 2005.

(51) **Int. Cl.**
H02P 23/00 (2006.01)

(52) **U.S. Cl.** **318/807; 318/561; 318/615; 318/431**

(58) **Field of Classification Search** 318/807, 318/508.18, 568.22, 561, 615, 616, 618, 318/560, 430, 431, 432, 433, 434; 388/805, 388/814, 820; 364/459

See application file for complete search history.

(56) **References Cited**

U.S. PATENT DOCUMENTS

4,288,726 A 9/1981 Vazquez-Cuervo et al.
4,633,157 A 12/1986 Streater
5,006,770 A * 4/1991 Sakamoto et al. 318/561

Systems and methods for controlling a rotating electromagnetic machine. The rotating machine, such as a permanent magnet motor or hybrid switched reluctance motor, includes a stator having a plurality of phase windings and a rotor that rotates relative to the stator. A drive is connected to the phase windings for energizing the windings. A controller outputs a control signal to the drive in response to an input demand such as a demanded speed or torque. Control methods (which can be implemented separately or in combination) include varying the gain of an estimator as a function of a demanded or estimated speed to position control system poles at desired locations, decoupling control system currents to achieve a constant torque with motor speed, compensating flux estimates of the estimator for saturation operation of the stator, estimating rotor position using averages of sample values of energization feedback, and calculating a trim adjusted speed error from a plurality of speed estimates.

23 Claims, 13 Drawing Sheets

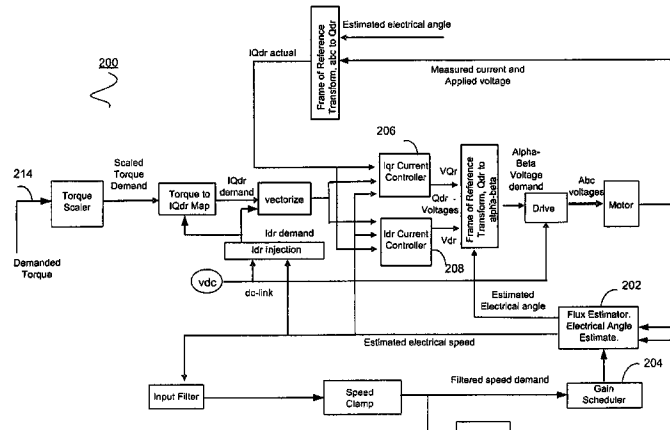

U.S. PATENT DOCUMENTS

5,495,162 A	2/1996	Rozman et al.	6,696,812 B2	2/2004	Kaneko et al.
5,498,945 A	3/1996	Prakash	6,731,083 B2	5/2004	Marcinkiewicz
5,569,994 A	10/1996	Taylor et al.	6,750,626 B2	6/2004	Leonardi et al.
5,635,810 A	6/1997	Goel	6,756,753 B1	6/2004	Marcinkiewicz et al.
5,736,823 A	4/1998	Nordby et al.	6,756,757 B2	6/2004	Marcinkiewicz et al.
5,747,971 A	5/1998	Rozman et al.	6,791,293 B2	9/2004	Kaitani
5,789,893 A	8/1998	Watkins	6,801,012 B1	10/2004	Islam et al.
5,801,935 A	9/1998	Sugden et al.	6,828,751 B2	12/2004	Sadasivam et al.
5,854,547 A	12/1998	Nakazawa	6,831,439 B2	12/2004	Won et al.
5,903,128 A	5/1999	Sakakibara et al.	6,874,221 B2	4/2005	Jansen et al.
5,929,590 A	7/1999	Tang	6,879,124 B1	4/2005	Jiang et al.
5,953,491 A	9/1999	Sears et al.	6,883,333 B2	4/2005	Shearer et al.
6,005,364 A	12/1999	Acamley	6,894,454 B2	5/2005	Patel et al.
6,081,093 A	6/2000	Oguro et al.	7,084,591 B2	8/2006	Kobayashi et al.
6,137,258 A	10/2000	Jansen	7,095,131 B2	8/2006	Mikhail et al.
6,232,692 B1	5/2001	Kliman	2003/0163226 A1*	8/2003	Tan 701/1
6,278,256 B1	8/2001	Aoyama			
6,297,621 B1	10/2001	Hui et al.			
6,304,052 B1	10/2001	O'Meara et al.			
6,326,750 B1	12/2001	Marcinkiewicz			
6,362,586 B1	3/2002	Naidu			
6,369,536 B2	4/2002	Beifus et al.			
6,404,154 B2	6/2002	Marcinkiewicz			
6,433,506 B1	8/2002	Pavlov et al.			
6,441,580 B2	8/2002	Marcinkiewicz			
6,443,873 B2	9/2002	Suzuki			
6,462,491 B1	10/2002	Iijima et al.			
6,515,395 B1	2/2003	Jansen			
6,515,442 B1*	2/2003	Okubo et al. 318/560			
6,567,282 B1	5/2003	Kikuchi et al.			
6,586,904 B2	7/2003	McClelland et al.			
6,603,226 B1	8/2003	Liang et al.			
6,628,099 B2	9/2003	Iwaji et al.			
6,661,194 B2	12/2003	Zaremba et al.			
6,690,137 B2	2/2004	Iwaji et al.			

OTHER PUBLICATIONS

“An AC Motor Closed Loop Performances With Different Rotor Flux Observers”, M. Alexandru, R. Bojoi, G. Ghelardi and S.M. Tenconi; pp. 1-7; prior to Jun. 24, 2005.

“Indirect Rotor-Position Estimation Techniques For Switched Reluctance Motors—A Review”; Iqbal Hussain; pp. 1-15; prior to Jun. 24, 2005.

“Lecture 9: State Observer And Output Feedback Controller”; pp. 1-14; May 16, 2005.

“Sensorless Motor Control Method For Compressor Applications”; Yashvant Jani; pp. 1-23; Mar. 29, 2005.

“Energy Conversion and Transport”; George G. Karady and Keith Holbert; Chapter 9, Introduction to Motor Control And Power Electronics; EE360; pp. 1-37; prior to Jun. 24, 2005.

“Minimum Error Entropy Luenberger Observer”; Jian-Wu Xu, Deniz Erdogmus and Jose C. Principe; pp. 1-13; prior to Jun. 24, 2005.

* cited by examiner

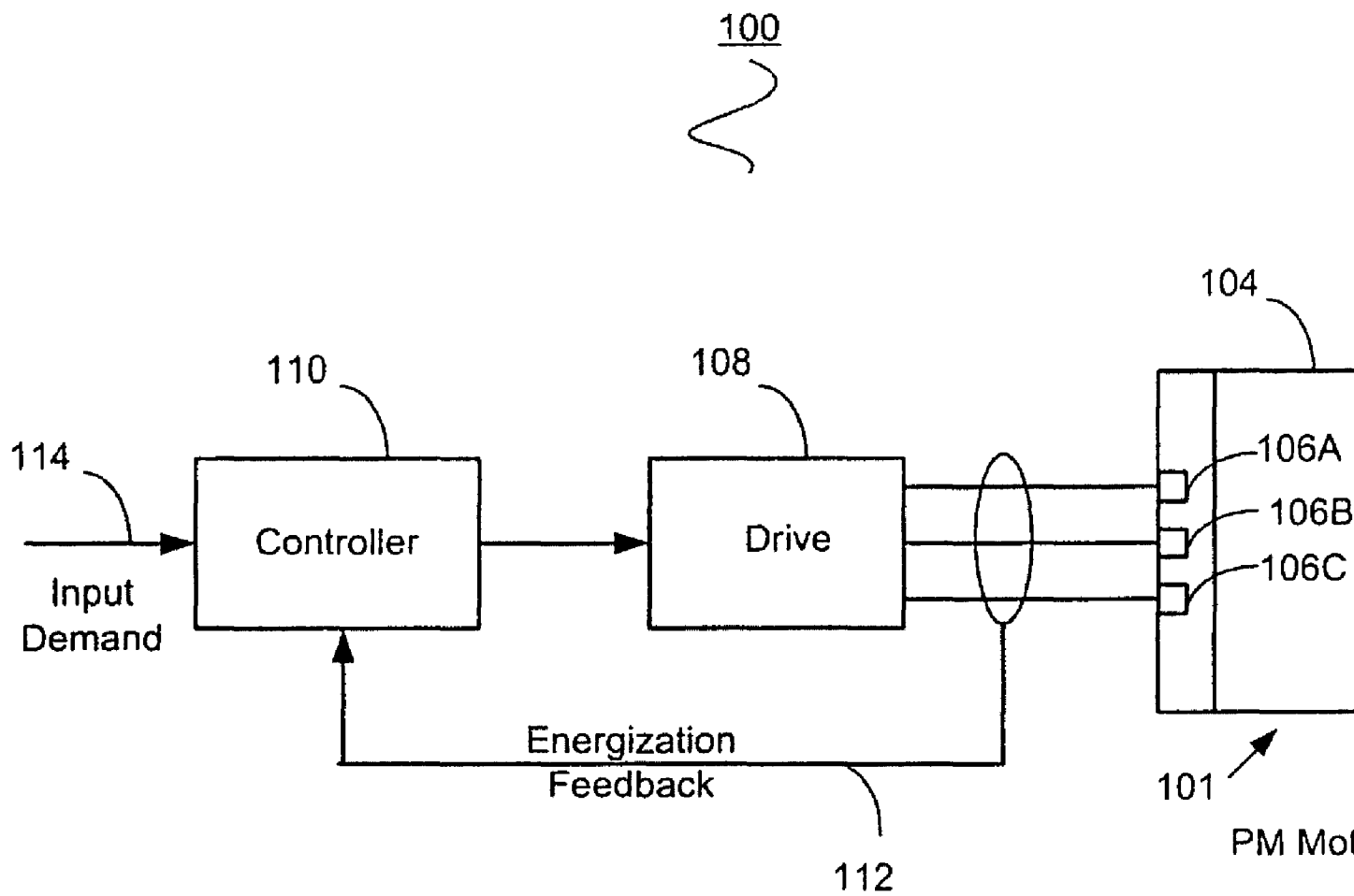

FIG. 1

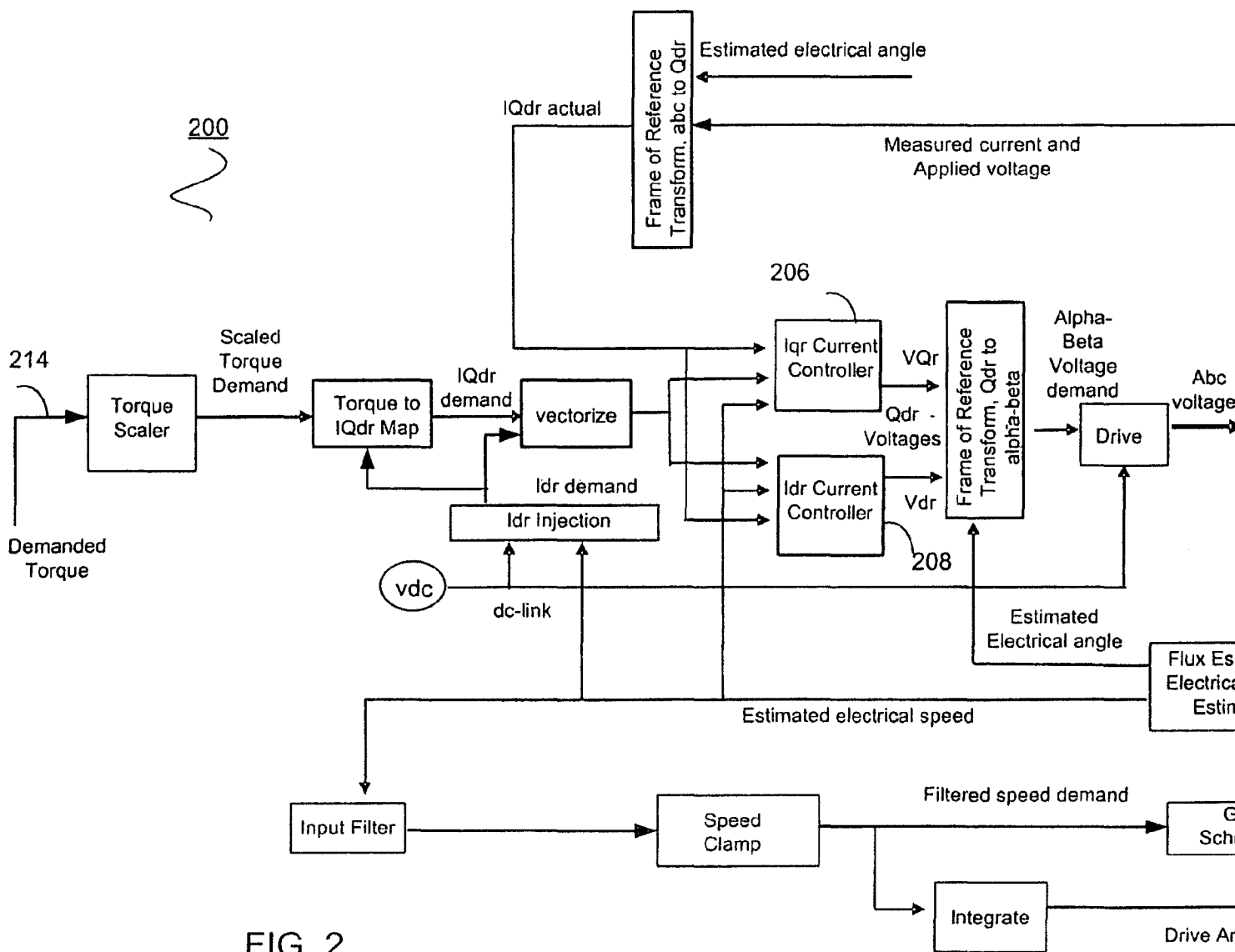

FIG. 2

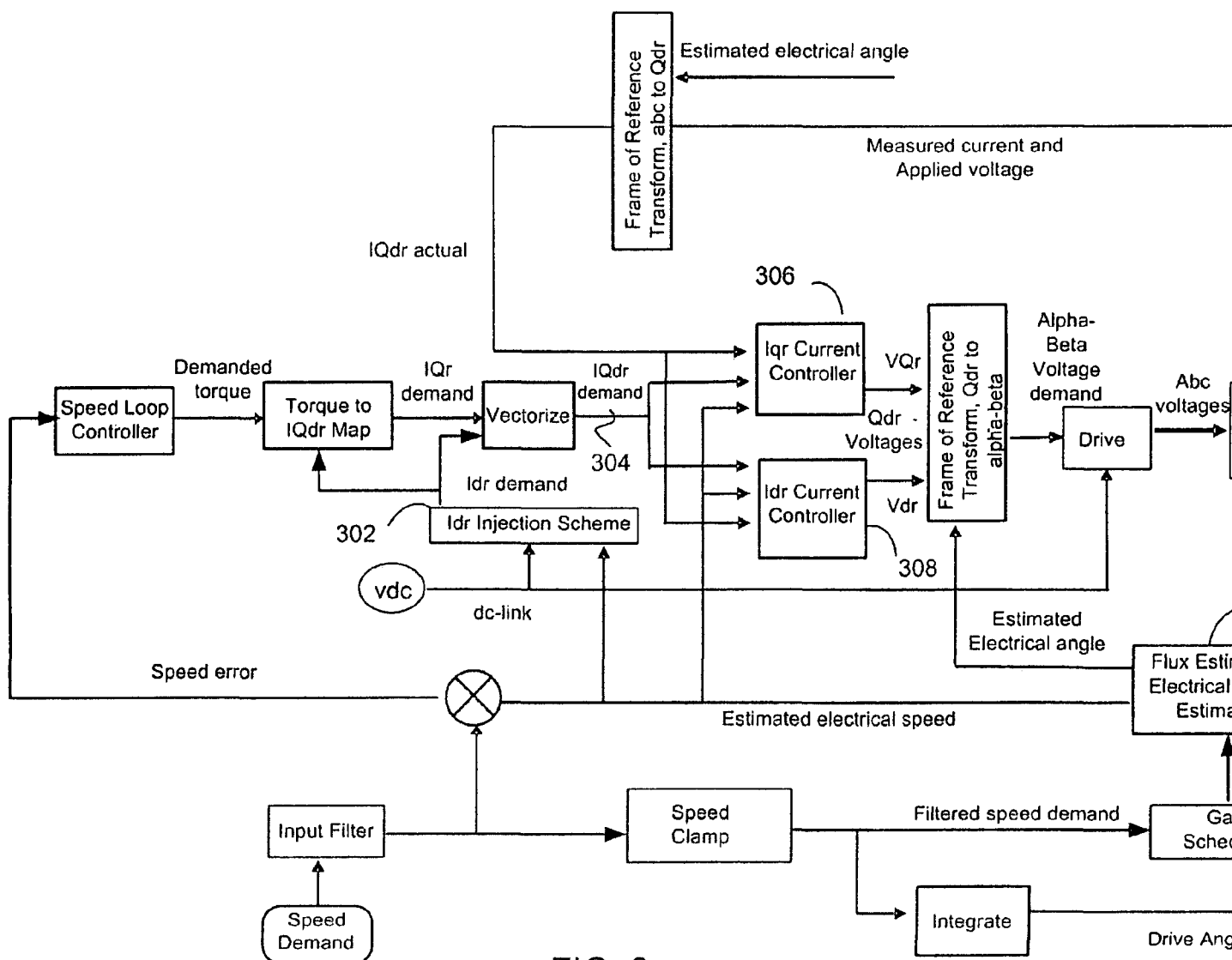

FIG. 3

Explore Litigation Insights

Docket Alarm provides insights to develop a more informed litigation strategy and the peace of mind of knowing you're on top of things.

Real-Time Litigation Alerts



Keep your litigation team up-to-date with **real-time alerts** and advanced team management tools built for the enterprise, all while greatly reducing PACER spend.

Our comprehensive service means we can handle Federal, State, and Administrative courts across the country.

Advanced Docket Research



With over 230 million records, Docket Alarm's cloud-native docket research platform finds what other services can't. Coverage includes Federal, State, plus PTAB, TTAB, ITC and NLRB decisions, all in one place.

Identify arguments that have been successful in the past with full text, pinpoint searching. Link to case law cited within any court document via Fastcase.

Analytics At Your Fingertips



Learn what happened the last time a particular judge, opposing counsel or company faced cases similar to yours.

Advanced out-of-the-box PTAB and TTAB analytics are always at your fingertips.

API

Docket Alarm offers a powerful API (application programming interface) to developers that want to integrate case filings into their apps.

LAW FIRMS

Build custom dashboards for your attorneys and clients with live data direct from the court.

Automate many repetitive legal tasks like conflict checks, document management, and marketing.

FINANCIAL INSTITUTIONS

Litigation and bankruptcy checks for companies and debtors.

E-DISCOVERY AND LEGAL VENDORS

Sync your system to PACER to automate legal marketing.