

UNITED STATES PATENT AND TRADEMARK OFFICE

BEFORE THE PATENT TRIAL AND APPEAL BOARD

TRW AUTOMOTIVE US LLC,
Petitioner,

v.

MAGNA ELECTRONICS INC.,
Patent Owner.

Cases IPR2014-00296, IPR2014-00297, and IPR2014-00298
Patent 8,324,552 B2

Before JUSTIN T. ARBES, BARRY L. GROSSMAN, and
BEVERLY M. BUNTING, *Administrative Patent Judges*.

BUNTING, *Administrative Patent Judge*.

DECISION
Denying Institution of *Inter Partes* Review
37 C.F.R. § 42.108

I. INTRODUCTION

TRW Automotive US LLC (“Petitioner”) filed three Petitions requesting *inter partes* review of claims 1, 4-6, 9-11, 15-18, 20-39, 41, 42, 44, 45, 53, 55, 58-64, 66-71, 73-87, and 90-104 of U.S. Patent No. 8,324,552 B2 (“the ’552 patent”). The patent owner, Magna Electronics Inc. (“Patent Owner”), filed a Preliminary Response in each of the three proceedings, as listed in the following chart:

| Case No. | Claims | Petition Paper No. | Preliminary Response Paper No. |
|---------------|--|----------------------|--------------------------------|
| IPR2014-00296 | 1, 4-6, 9-11, 15-18, 20-39, 41, 42, 44, 45, 53, 55, and 58-60 ¹ | 1 (“296 Pet.”) | 8 (“296 Prelim. Resp.”) |
| IPR2014-00297 | 61-64, 66-71, and 73-87 | 1 (“297 Pet.”) | 8 (“297 Prelim. Resp.”) |
| IPR2014-00298 | 90-104 ² | 1 (“298 Pet.”) | 12 (“298 Prelim. Resp.”) |

Cases IPR2014-00296, IPR2014-00297, and IPR2014-00298 involve the same patent and parties, and there is overlap in the asserted prior art and additional evidence submitted by Petitioner.

The standard for instituting an *inter partes* review is set forth in 35 U.S.C. § 314(a):

¹ Claims 34-37 were omitted from the listing of challenged claims in Section II.A. of the IPR2014-00296 petition; however, Petitioner provided arguments challenging the patentability of claims 34-37. 296 Pet. 4, 53-56.

² Claims 90 and 101 were omitted from the listing of challenged claims in Section II.A. of the IPR2014-00298 petition; however, Petitioner provided arguments challenging the patentability of claims 90 and 101. 298 Pet. 4, 15-22, and 25-26.

THRESHOLD.— The Director may not authorize an *inter partes* review to be instituted unless the Director determines that the information presented in the petition filed under section 311 and any response filed under section 313 shows that there is a reasonable likelihood that the petitioner would prevail with respect to at least 1 of the claims challenged in the petition.

We have jurisdiction under 35 U.S.C. § 314. Upon consideration of the Petitions and Preliminary Responses, we determine that the information presented does not show that there is a reasonable likelihood that Petitioner would prevail in establishing the unpatentability of any challenged claim of the '552 patent for the reasons that follow. Accordingly, we deny the Petitions and do not institute an *inter partes* review of the '552 patent.

A. Related Proceedings

TRW states that the '552 patent is involved in a pending district court infringement action, *Magna Electronics Inc. v. TRW Automotive Holding Corp.*, Case No. 1:12-cv-00654-PLM (W.D. Mich.). Pet. 4-5.

B. The '552 Patent

The '552 patent relates generally to an image sensing system for a vehicle, and, in particular, to a system for controlling the headlights of the vehicle. Ex. 1002, 1:24-26. The disclosed system particularly is adapted to controlling the vehicle's headlamps in response to sensing the headlights of oncoming vehicles and taillights of leading vehicles. *Id.* at 1:26-29. The image processing system is capable of identifying unique characteristics of light sources by comparing light source characteristics with spectral signatures of known light sources, such as headlights and taillights. *Id.* at 1:67-2:9.

As shown generally in Figure 2 of the '552 patent, reproduced below, the image processing system includes imaging sensor module 14, which senses light

from a scene forward of the vehicle; imaging control circuit 13,³ which receives data from sensor 14; and vehicle lighting control logic module 16, which exchanges data with control circuit 13 and controls headlamps 18 for the purpose of modifying the headlight beam. *Id.* at 3:44-51.

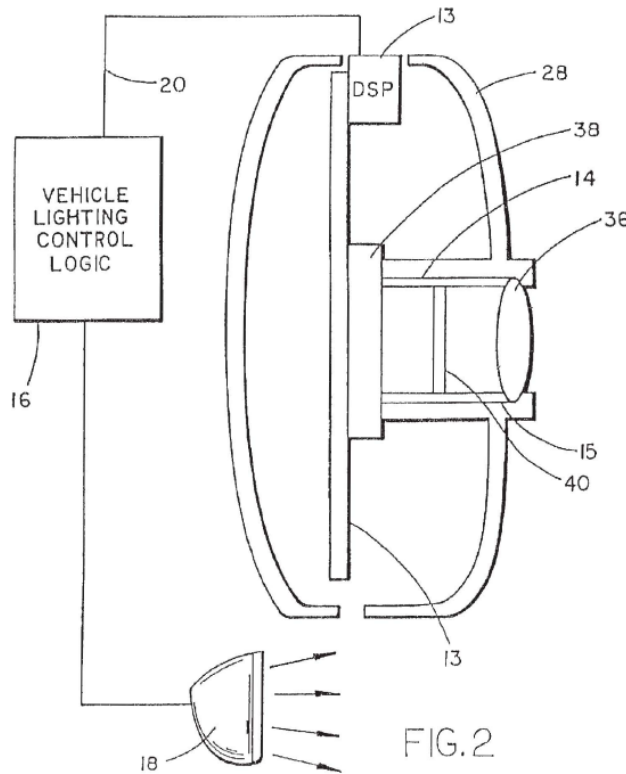

Figure 2 of the '552 patent is a partial side view of a vehicle headlight dimming control system.

Imaging sensor module 14 includes a lens, an array of photon-accumulating light sensors, and a spectral separation device, such as a filter array, for separating light from the scene forward of the vehicle into a plurality of spectral bands. *Id.* at

³ The Specification also refers to imaging control circuit 13 as a “digital signal processor.” See Ex. 1002, 3:47 (“imaging control circuit 13”), 4:53–54 (“digital signal processor 13”). This explains why reference numeral 13 in Figure 2 points to a box labelled “DSP,” i.e., digital signal processor.

4:24-29. Digital signal processor 13 includes an analog-to-digital converter, which receives the output of the array of photon-accumulating light sensors and converts the analog pixel values to digital values. *Id.* at 4:56-58. The digital values are supplied to a taillight detection circuit and a headlight detection circuit. *Id.* at 4:58-60.

The taillight detection circuit detects a red light source having intensity above a particular threshold. *Id.* at 5:4-5. For each pixel that is “red,” a comparison is made with adjacent “green” pixels and “blue” pixels. *Id.* at 5:6-7. If the intensity of a red pixel is more than a particular number of times the intensity of an adjacent green pixel and an adjacent blue pixel, then it is determined that the light source is red. *Id.* at 5:7-10. The headlight detection circuit carries out a similar process. *Id.* at 5:13-21. The image processing system recognizes the spectral signatures of detected light sources, i.e., headlights and taillights, as well as the spectral signatures of rejected light sources, such as lane markers, signs, and other sources of reflected light, all of which may be identified readily by their spectral signature. *Id.* at 10:38-47.

C. Illustrative Claim

Petitioner challenges claims 1, 4-6, 9-11, 15-18, 20-39, 41, 42, 44, 45, 53, 55, 58-64, 66-71, 73-87, and 90-104 of the '552 patent. Of the challenged claims, claims 1, 61, 79, and 90 are independent claims. Claim 1, reproduced below, is illustrative and reads as follows:

1. An image sensing system for a vehicle, said image sensing system comprising:
 - an imaging sensor comprising a two-dimensional CMOS array of light sensing photosensor elements;
 - wherein said imaging sensor has a forward field of view to the exterior of a windshield of a vehicle equipped with said image sensing system;

Explore Litigation Insights

Docket Alarm provides insights to develop a more informed litigation strategy and the peace of mind of knowing you're on top of things.

Real-Time Litigation Alerts



Keep your litigation team up-to-date with **real-time alerts** and advanced team management tools built for the enterprise, all while greatly reducing PACER spend.

Our comprehensive service means we can handle Federal, State, and Administrative courts across the country.

Advanced Docket Research



With over 230 million records, Docket Alarm's cloud-native docket research platform finds what other services can't. Coverage includes Federal, State, plus PTAB, TTAB, ITC and NLRB decisions, all in one place.

Identify arguments that have been successful in the past with full text, pinpoint searching. Link to case law cited within any court document via Fastcase.

Analytics At Your Fingertips



Learn what happened the last time a particular judge, opposing counsel or company faced cases similar to yours.

Advanced out-of-the-box PTAB and TTAB analytics are always at your fingertips.

API

Docket Alarm offers a powerful API (application programming interface) to developers that want to integrate case filings into their apps.

LAW FIRMS

Build custom dashboards for your attorneys and clients with live data direct from the court.

Automate many repetitive legal tasks like conflict checks, document management, and marketing.

FINANCIAL INSTITUTIONS

Litigation and bankruptcy checks for companies and debtors.

E-DISCOVERY AND LEGAL VENDORS

Sync your system to PACER to automate legal marketing.