

UNITED STATES PATENT AND TRADEMARK OFFICE

BEFORE THE PATENT TRIAL AND APPEAL BOARD

OMRON OILFIELD & MARINE, INC.
Petitioner

v.

MD/TOTCO, A DIVISION OF VARCO, L.P.
Patent Owner

Case IPR2013-00265
Patent 5,474,142

Before THOMAS L. GIANNETTI, BRYAN F. MOORE, and
MICHAEL J. FITZPATRICK, *Administrative Patent Judges*.

MOORE, *Administrative Patent Judge*.

DECISION
Institution of *Inter Partes* Review
37 C.F.R. § 42.108

I. INTRODUCTION

A. *Background*

Omron Oilfield & Marine, Inc. (“Petitioner”) requests an *inter partes* review of claims 1, 11, and 14 of U.S. Patent 5,474,142 (“the ’142 Patent”), pursuant to 35 U.S.C. §§ 311 *et seq.* Paper 1 (Pet.). The patent owner, MD/Totco, a division of Varco, L.P. (“Patent Owner”), timely filed a preliminary response. Paper 10 (“Prelim. Resp.”).

The standard for instituting an *inter partes* review is set forth in 35 U.S.C. § 314(a), which provides as follows:

THRESHOLD – The Director may not authorize an *inter partes* review to be instituted unless the Director determines that the information presented in the petition filed under section 311 and any response filed under section 313 shows that there is a reasonable likelihood that the petitioner would prevail with respect to at least 1 of the claims challenged in the petition.

Petitioner contends that the challenged claims are unpatentable under 35 U.S.C. §§ 102 and/or 103 on the following specific grounds¹:

Reference(s)	Basis	Claims challenged
Lindstad U.S. Patent 3,613,805 (Ex. 1013)	§ 102	1, 11, and 14
Warren U.S. Patent 4,854,397 (Ex. 1018)	§ 102	1, 11, and 14
Miller U.S. Patent 3,463,252 (Ex. 1022)	§ 102	1 and 11
Lindstad and Crake U.S. Patent 2,455,917 (Ex. 1015)	§ 103	1, 11, and 14
Lindstad and Brooks U.S. Patent 3,324,717 (Ex. 1017)	§ 103	1, 11, and 14

¹ Petitioner supports its challenge with a declaration by Mitchell Pinckard (Ex. 1012) (“Pinckard Decl.”).

Reference(s)	Basis	Claims challenged
Warren and Brooks	§ 103	1, 11, and 14
Miller and Crake	§ 103	14
Le Compte U.S. Patent 1,891,329 (Ex. 1023) and Crake	§ 103	14

For the reasons given below, we deny the petition and decline to institute an *inter partes* review of the '142 Patent.

B. *Related Proceedings*

The '142 Patent has been asserted in the following actions: *National Oilwell Varco, LP v. Omron Oilfield & Marine, Inc.* (W.D. Tex. Case No. 12-cv-00773) (filed 8/23/12, still pending); *National Oilwell Varco, LP v. Pason Sys. USA, Corporation* (W.D. Tex. Case No. 12-cv-01113) (filed 12/7/12, still pending); *National Oilwell Varco, LP v. Pason Sys. USA Corp.* (D. Colo. Case No. 03-cv-02579; Fed. Cir. Case Nos. 2012-1551, 2012-1587) (appeal pending) (“the Colorado litigation”); *Bowden v. Tech Power Controls* (S.D. Tex. Case No. 00-cv-00271) (dismissed); *Bowden v. Martin-Decker Totco* (W.D. Tex. Case No. 99-cv-00607) (dismissed); *Varco LP v. IDM Equip. Co. Inc.* (S.D. Tex. Case No. 05-cv-00767) (dismissed); *National Oilwell Varco, LP v. Auto-Dril, Inc.* (E.D. Tex. Case No. 09-cv-00085) (dismissed); and *Bowden v. Dick’s Oilfield* (W.D. Tex Case No. 5:98-cv-01174-FB). Pet. 1-2; Prelim. Resp. 1-2.

C. *'142 Patent*

The '142 Patent (Ex. 1001) is titled “Automatic Drilling System,” and relates generally to an automatic drilling system that regulates the release of the drill string of a drilling rig in response to, among other things, drilling fluid

pressure and bit weight. '142 Patent Abstract. Figure 1 of the '142 Patent depicts the basic components of a drilling rig.

Figure 1 is reproduced below:

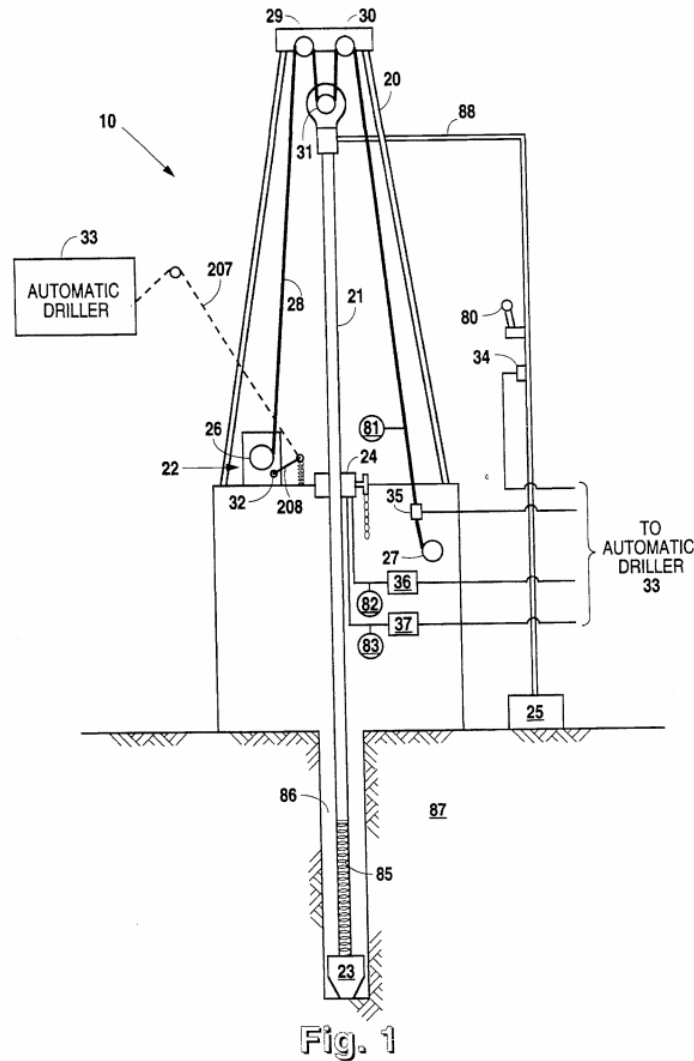

Figure 1 depicts a drilling rig with an automatic driller. Ex. 1001, col. 3, ll. 53-64. Drill string 21 extends into the borehole 86 utilizing drawworks 22. *Id.*, col. 3, ll. 55-56. Brake 32 controls the release of cable 28 to adjust the vertical position of drill string 21. *Id.*, col. 3, ll. 61-63. Drill bit 23 is located at the end of drill string 21. *Id.*, col. 3, ll. 65-66. Rotary table 24 drives drill string 21 to rotate drill bit 23 to achieve the drilling of the borehole. *Id.* Drilling fluid (i.e., mud) is pumped into

drill string 21 and “drives mud motor 85, provides pressure within drill bit 23 to prevent blowouts, and carries drilled formation materials from borehole 86.” *Id.*, col. 4, ll. 10-25. The object of the invention is to operate not only through bit weight measurements, “but also operate[] in response to other measurements so that directional or horizontal boreholes may be drilled,” as opposed to strictly vertical boreholes. *Id.*, col. 1, ll. 51-54.

Claims 1, 11, and 14, at issue in this petition, are reproduced below.

1. An automatic drilling system for automatically regulating the release of the drill string of a drilling rig having a drill bit in association therewith during the drilling of a borehole, comprising:

a drilling fluid pressure sensor; and

a drilling fluid pressure regulator coupled to said drilling fluid pressure sensor, said drilling fluid pressure regulator measuring changes in drilling fluid pressure and outputting a signal representing those changes;

a relay coupled to said drilling fluid pressure regulator, said relay responsive to the output signal of said drilling fluid pressure regulator to supply a drill string control signal at an output thereof; and

a drill string controller coupled to said relay wherein a decrease in drilling fluid pressure results in said relay supplying a drill string control signal that operates said drill string controller to effect an increase in the rate of release of said drill string with direct effect at the drill bit associated with the drill string and an increase in drilling fluid pressure results in said relay supplying a drill string control signal that operates said drill string controller to effect a decrease in the rate of release of said drill string with direct effect at the drill bit associated with the drill string.

Explore Litigation Insights

Docket Alarm provides insights to develop a more informed litigation strategy and the peace of mind of knowing you're on top of things.

Real-Time Litigation Alerts



Keep your litigation team up-to-date with **real-time alerts** and advanced team management tools built for the enterprise, all while greatly reducing PACER spend.

Our comprehensive service means we can handle Federal, State, and Administrative courts across the country.

Advanced Docket Research



With over 230 million records, Docket Alarm's cloud-native docket research platform finds what other services can't. Coverage includes Federal, State, plus PTAB, TTAB, ITC and NLRB decisions, all in one place.

Identify arguments that have been successful in the past with full text, pinpoint searching. Link to case law cited within any court document via Fastcase.

Analytics At Your Fingertips



Learn what happened the last time a particular judge, opposing counsel or company faced cases similar to yours.

Advanced out-of-the-box PTAB and TTAB analytics are always at your fingertips.

API

Docket Alarm offers a powerful API (application programming interface) to developers that want to integrate case filings into their apps.

LAW FIRMS

Build custom dashboards for your attorneys and clients with live data direct from the court.

Automate many repetitive legal tasks like conflict checks, document management, and marketing.

FINANCIAL INSTITUTIONS

Litigation and bankruptcy checks for companies and debtors.

E-DISCOVERY AND LEGAL VENDORS

Sync your system to PACER to automate legal marketing.