

EXHIBIT B.01
U.S. Patent No. 7,604,716

References cited herein:

- U.S. Patent No. 7,604,716 (“716 Patent”)
- D.V. Mozgrin, *et al*, High-Current Low-Pressure Quasi-Stationary Discharge in a Magnetic Field: Experimental Research, Plasma Physics Reports, Vol. 21, No. 5, 1995 (“Mozgrin”)
- Dennis M. Manos & Daniel L. Flamm, Plasma Etching: An Introduction, Academic Press 1989 (“Manos”)
- Milton Ohring, The Material Science of Thin Films, Academic Press, 1992 (“Ohring”)

Claims 1-5, 8-11, and 33	Mozgrin
1. An apparatus for generating a strongly-ionized plasma, the apparatus comprising:	<p>Mozgrin discloses an apparatus for generating a strongly-ionized plasma.</p> <p>‘716 Patent at claim 24 (“wherein the peak plasma density of the strongly-ionized plasma is greater than about 10^{12} cm⁻³”)</p> <p>Mozgrin at Fig 1</p> <p>Mozgrin at 400, right col, ¶ 4 (“To study the high-current forms of the discharge, we used two types of devices: a planar magnetron and a system with specifically shaped hollow electrodes.”)</p> <p>Mozgrin at 401, right col, ¶2 (“For pre-ionization ... the initial plasma density in the $10^9 - 10^{11}$ cm⁻³ range.”)</p> <p>Mozgrin at 409, left col, ¶ 4 (“The implementation of the high-current magnetron discharge (regime 2) in sputtering ... plasma density (exceeding 2×10^{13} cm⁻³).”)</p> <p>Mozgrin at 409, left col, ¶5 (“The high-current diffuse discharge (regime 3) is useful for producing large-volume uniform dense plasmas $n_i \cong 1.5 \times 10^{15}$ cm⁻³ ...”).</p>
a. an ionization source that generates a weakly-ionized plasma from a feed gas contained in a chamber,	<p>Mozgrin discloses an ionization source that generates a weakly-ionized plasma from a feed gas contained in a chamber.</p> <p>‘716 Patent at 5:14-15 (“The weakly-ionized plasma 232 is also referred to as a pre-ionized plasma.”)</p> <p>‘716 Patent at claim 23 (“wherein the peak plasma density of the weakly-ionized plasma is less than about 10^{12} cm⁻³”)</p>

INTEL 1020

EXHIBIT B.01
U.S. Patent No. 7,604,716

Claims 1-5, 8-11, and 33	Mozgrin
	<p>Mozgrin at Figs. 1, 2, 3, 6, 7</p> <p>Mozgrin at 401, left col, ¶ 1 (“The [plasma] discharge had an annular shape and was adjacent to the cathode.”)</p> <p>Mozgrin at 401, left col, ¶ 4 (“[A]pplying a square voltage pulse to the discharge gap which was filled up with either neutral or pre-ionized gas.”)</p> <p>Mozgrin at 402, right col, ¶2 (“Figure 3 shows typical voltage and current oscillograms.... Part I in the voltage oscillogram represents the voltage of the stationary discharge (pre-ionization stage).”)</p> <p>Mozgrin at 401, right col, ¶2 (“[f]or pre-ionization, we used a stationary magnetron discharge; ... provided the initial plasma density in the $10^9 - 10^{11} \text{ cm}^{-3}$ range.”)</p> <p>Mozgrin at 400, right col, ¶ 3 (“We investigated the discharge regimes in various gas mixtures at $10^{-3} - 10$ torr...”)</p> <p>Mozgrin at 402, ¶ spanning left and right cols (“We studied the high-current discharge in wide ranges of discharge current...and operating pressure...using various gases (Ar, N₂, SF₆, and H₂) or their mixtures of various composition...”)</p>
the weakly-ionized plasma substantially eliminating the probability of developing an electrical breakdown condition in the chamber; and	<p>Mozgrin discloses the weakly-ionized plasma substantially eliminating the probability of developing an electrical breakdown condition in the chamber.</p> <p>Mozgrin at 406, right col, ¶3 (“pre-ionization was not necessary; however, in this case, the probability of discharge transferring to arc mode increased.”).</p> <p>Mozgrin at Figs. 4 and 7.</p> <p>Mozgrin at 400, left col, ¶ 3 (“Some experiments on magnetron systems of various geometry showed that discharge regimes which do not transit to arcs can be obtained even at high currents.”)</p> <p>Mozgrin at 400, right col, ¶ 1 (“A further increase in the discharge currents caused the discharges to transit to the arc regimes...”).</p> <p>Mozgrin at 404, left col, ¶ 4 (“The parameters of the shaped-electrode discharge transit to regime 3, as well as the condition of its transit to arc</p>

EXHIBIT B.01
U.S. Patent No. 7,604,716

Claims 1-5, 8-11, and 33	Mozgrin
	<p>regime 4, could be well determined for every given set of the discharge parameters.”).</p> <p>Mozgrin at 403, left col, ¶ 2. (“Then, we studied regimes 2 and 3 separately to determine the boundary parameters of their occurrence, such as current, voltage....”).</p> <p>Mozgrin at 400, right col, ¶ 1 (“A further increase in the discharge currents caused the discharges to transit to the arc regimes....”).</p> <p>Mozgrin 404, left col, ¶ 4 (“If the current was raised above 1.8 kA or the pulse duration was increase to 2 – 10 ms, an instability development and discharge contraction was observed.”).</p> <p><u>Background:</u> Manos at 231 (“We shall ... [include] information on unipolar arcs. These are a problem...”)</p> <p>Manos at 237 (“When such an arc occurs, the metal object is melted at the arc spot. The metal is explosively released.... How does one prevent such an arc? There are several methods...”)</p>
<p>b. a power supply that supplies power to the weakly-ionized plasma though an electrical pulse that is applied across the weakly-ionized plasma, the electrical pulse having at least one of a magnitude and a rise-time that is sufficient to transform the weakly-ionized plasma to a strongly-ionized plasma without developing an</p>	<p>Mozgrin discloses a power supply that supplies power to the weakly-ionized plasma though an electrical pulse that is applied across the weakly-ionized plasma, the electrical pulse having at least one of a magnitude and a rise-time that is sufficient to transform the weakly-ionized plasma to a strongly-ionized plasma without developing an electrical breakdown condition in the chamber.</p> <p>‘716 Patent at claim 23 (“wherein the peak plasma density of the weakly-ionized plasma is less than about 10^{12} cm⁻³”)</p> <p>‘716 Patent at claim 24 (“wherein the peak plasma density of the strongly-ionized plasma is greater than about 10^{12} cm⁻³”)</p> <p>Mozgrin at Fig. 1</p>

EXHIBIT B.01
U.S. Patent No. 7,604,716

Claims 1-5, 8-11, and 33	Mozgrin
---------------------------------	----------------

electrical breakdown condition in the chamber.

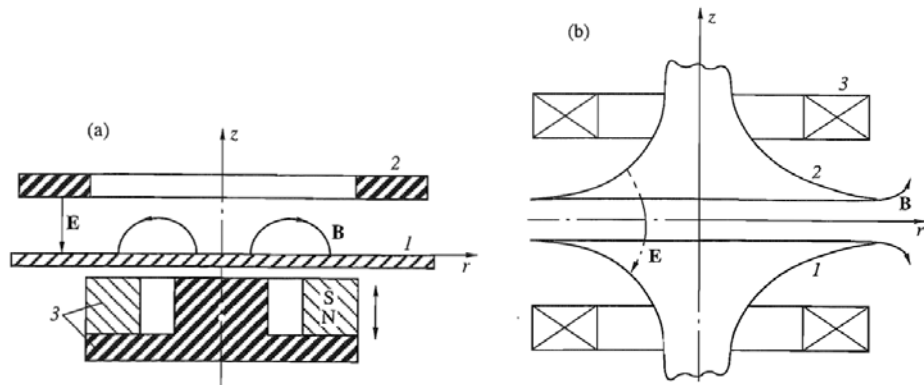

Fig. 1. Discharge device configurations: (a) planar magnetron; (b) shaped-electrode configuration. (1) Cathode; (2) anode; (3) magnetic system.

Mozgrin at Fig. 2

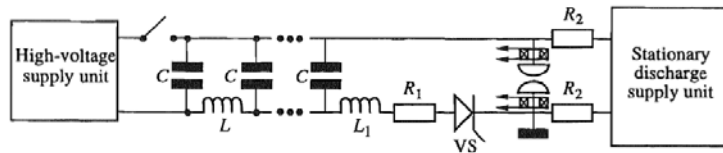

Fig. 2. Discharge supply unit.

Mozgrin at Fig. 3

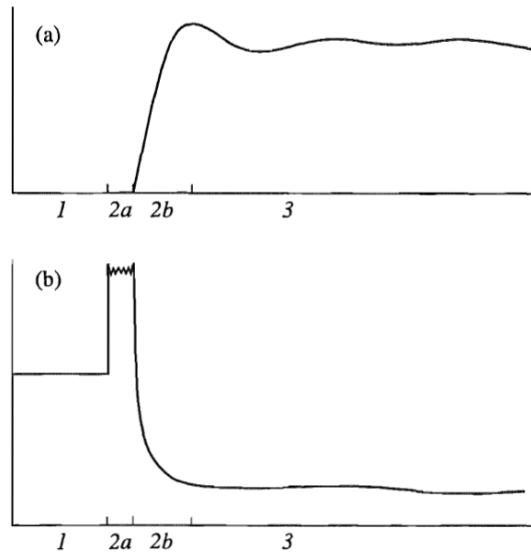

Fig. 3. Oscillograms of (a) current and (b) voltage of the quasi-stationary discharge (50 μ s per div., 180 A per div., 180 V per div.).

Mozgrin at 402, right col, ¶ 2 (“Part 1 in the voltage oscillogram

EXHIBIT B.01
U.S. Patent No. 7,604,716

Claims 1-5, 8-11, and 33	Mozgrin
	<p>represents the voltage of the stationary discharge (pre-ionization stage).”)</p> <p>Mozgrin at 401, right col, ¶ 1 (“Thus, the supply unit was made providing square voltage and current pulses with [rise] times (leading edge) of 5 – 60 μs...”).</p> <p>Mozgrin 403, right col, ¶4 (“Regime 2 was characterized by intense cathode sputtering...”) (emphasis added).</p> <p>Mozgrin at 409, left col, ¶ 4 (“The implementation of the high-current magnetron discharge (regime 2) in sputtering ... plasma density (exceeding $2 \times 10^{13} \text{ cm}^{-3}$).”).</p> <p>Mozgrin at 409, left col, ¶5 (“The high-current diffuse discharge (regime 3) is useful for producing large-volume uniform dense plasmas $n_i \cong 1.5 \times 10^{15} \text{ cm}^{-3}$...”)</p> <p>Mozgrin at 401, ¶ spanning left and right columns (“Designing the [pulsed supply] unit, we took into account the dependences which had been obtained in [Kudryavtsev] of ionization relaxation on pre-ionization parameters, pressure, and pulse voltage amplitude.”)</p> <p>Mozgrin at 400, left col, ¶ 3 (“Some experiments on magnetron systems of various geometry showed that discharge regimes which do not transit to arcs can be obtained even at high currents.”)</p> <p>Mozgrin at 400, right col, ¶ 1 (“A further increase in the discharge currents caused the discharges to transit to the arc regimes...”).</p> <p>Mozgrin at 401, right col, ¶2 (“For pre-ionization ... the initial plasma density in the $10^9 - 10^{11} \text{ cm}^{-3}$ range.”)</p> <p>Mozgrin at 404, left col, ¶ 3 (“The parameters of the shaped-electrode discharge...transit to arc regime 4, could be well determined... The point of the planar-magnetron discharge transit to the arc regime was determined by discharge voltage and structure changes...”).</p> <p>Mozgrin at 404, left col, ¶ 4 (“If the current was raised above 1.8 kA or the pulse duration was increase to 2 – 10 ms, an instability development and discharge contraction was observed.”).</p> <p>Mozgrin at Fig. 4</p>

Explore Litigation Insights

Docket Alarm provides insights to develop a more informed litigation strategy and the peace of mind of knowing you're on top of things.

Real-Time Litigation Alerts



Keep your litigation team up-to-date with **real-time alerts** and advanced team management tools built for the enterprise, all while greatly reducing PACER spend.

Our comprehensive service means we can handle Federal, State, and Administrative courts across the country.

Advanced Docket Research



With over 230 million records, Docket Alarm's cloud-native docket research platform finds what other services can't. Coverage includes Federal, State, plus PTAB, TTAB, ITC and NLRB decisions, all in one place.

Identify arguments that have been successful in the past with full text, pinpoint searching. Link to case law cited within any court document via Fastcase.

Analytics At Your Fingertips



Learn what happened the last time a particular judge, opposing counsel or company faced cases similar to yours.

Advanced out-of-the-box PTAB and TTAB analytics are always at your fingertips.

API

Docket Alarm offers a powerful API (application programming interface) to developers that want to integrate case filings into their apps.

LAW FIRMS

Build custom dashboards for your attorneys and clients with live data direct from the court.

Automate many repetitive legal tasks like conflict checks, document management, and marketing.

FINANCIAL INSTITUTIONS

Litigation and bankruptcy checks for companies and debtors.

E-DISCOVERY AND LEGAL VENDORS

Sync your system to PACER to automate legal marketing.