



US006306265B1

(12) **United States Patent**
Fu et al.

(10) **Patent No.:** **US 6,306,265 B1**
(45) **Date of Patent:** **Oct. 23, 2001**

(54) **HIGH-DENSITY PLASMA FOR IONIZED METAL DEPOSITION CAPABLE OF EXCITING A PLASMA WAVE**

2 241 710 * 9/1991 (GB) 204/298.19
62-89864 4/1987 (JP) .
63-282263 11/1988 (JP) .
11-074225 3/1999 (JP) .

(75) Inventors: **Jianming Fu**, San Jose; **Praburam Gopalraja**, Sunnyvale; **Fusen Chen**, Saratoga; **John Forster**, San Francisco, all of CA (US)

OTHER PUBLICATIONS

B. Window et al. "Charged particle fluxes from planar magnetron sources", J. Vac. Sci. Technol. A 4(2), Mar./Apr. 1986, pp. 196-202.*

(73) Assignee: **Applied Materials, Inc.**, Santa Clara, CA (US)

J. Musil, et al. "Unbalanced magnetrons and new sputtering systems with enhanced plasma ionization", J. Vac. Sci. Technol. A 9(3), May/Jun. 1991, pp. 1171-1177.*

(*) Notice: Subject to any disclaimer, the term of this patent is extended or adjusted under 35 U.S.C. 154(b) by 0 days.

W. Munz "The unbalanced magnetron: current status of development", Surface and Coatings Technology, 48 (1991), pp. 81-94.*

(21) Appl. No.: **09/546,798**

Matsuoka et al., "Dense plasma production and film deposition by new high-rate sputtering using an electric mirror," *Journal of Vacuum Science and Technology A*, vol. 7, No. 4, Jul./Aug. 1989, pp. 2652-2657.

(22) Filed: **Apr. 11, 2000**

* cited by examiner

Related U.S. Application Data

(63) Continuation-in-part of application No. 09/373,097, filed on Aug. 12, 1999, now Pat. No. 6,183,614, which is a continuation-in-part of application No. 09/249,468, filed on Feb. 12, 1999.

Primary Examiner—Nam Nguyen

Assistant Examiner—Gregg Cantelmo

(74) *Attorney, Agent, or Firm*—Charles S. Guenzer, Esq

(51) **Int. Cl.**⁷ **C23C 14/34**

(57) **ABSTRACT**

(52) **U.S. Cl.** **204/192.12; 204/298.2**

A magnetron especially advantageous for low-pressure plasma sputtering or sustained self-sputtering having reduced area but full target coverage. The magnetron includes an outer pole face surrounding an inner pole face with a gap therebetween. The outer pole of the magnetron of the invention is smaller than that of a circular magnetron similarly extending from the center to the periphery of the target. A preferred triangular shape having a small apex angle of 20 to 30° may be formed from outer bar magnets of one magnetic polarity enclosing an inner magnet of the other magnetic polarity. The magnetron allows the generation of plasma waves in the neighborhood of 22 MHz which interact with the 1 to 20 eV electrons of the plasma to thereby increase the plasma density.

(58) **Field of Search** 204/298.19, 298.2, 204/298.22, 192.12

(56) **References Cited**

U.S. PATENT DOCUMENTS

4,444,643 * 4/1984 Garrett 204/298.2
5,252,758 10/1993 Demaray et al. 204/298.2
5,770,025 6/1998 Kiyota 204/298.2
5,897,752 * 4/1999 Hong et al. 204/298.2
5,966,607 * 10/1999 Chee et al. 438/305

FOREIGN PATENT DOCUMENTS

06-620583A 10/1994 (EP) .
0 691 419 A1 * 1/1996 (EP) 204/298.19

22 Claims, 11 Drawing Sheets

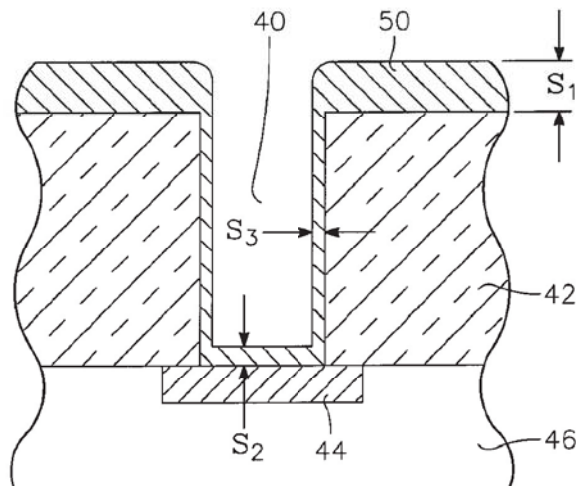

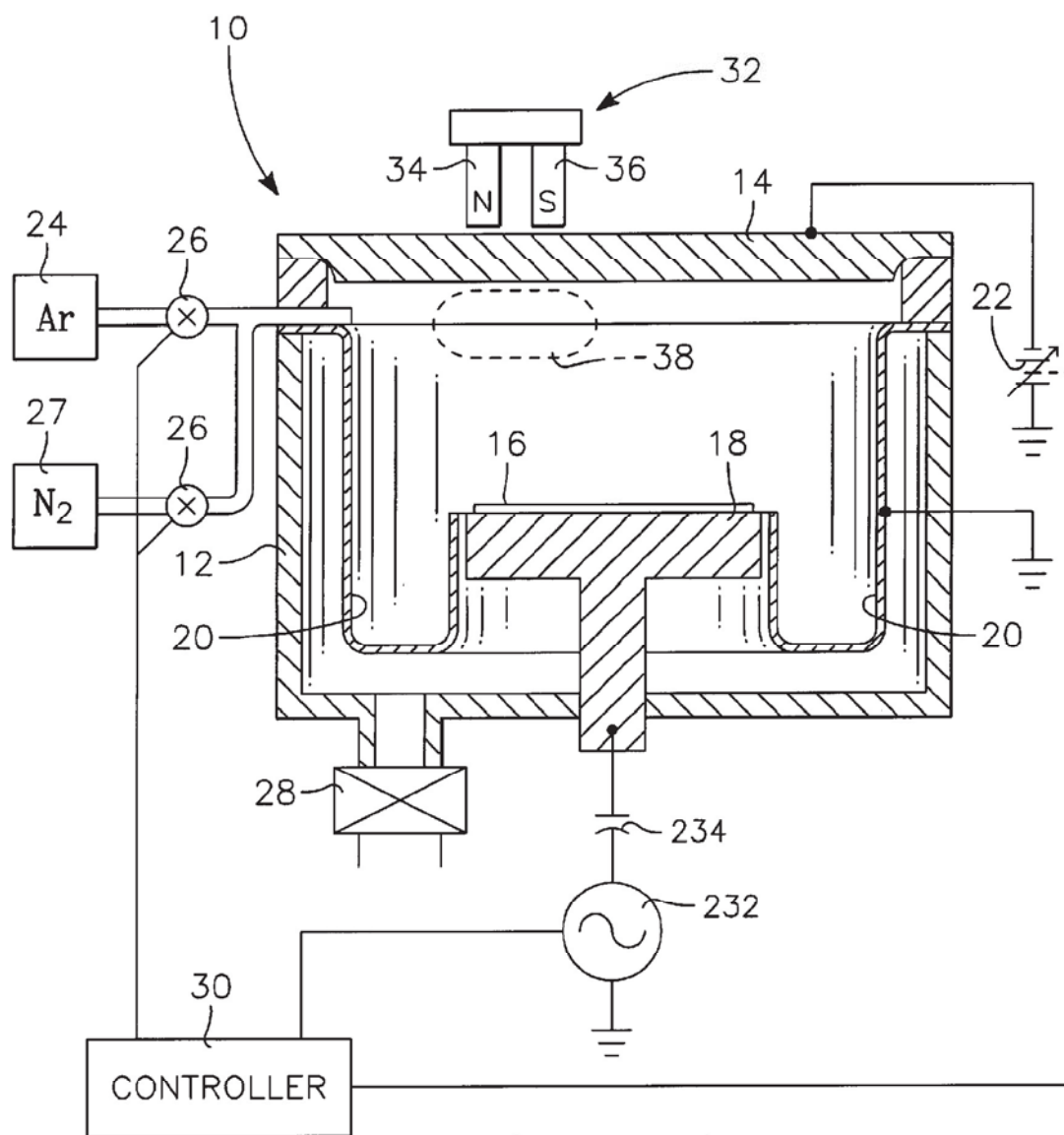

(PRIOR ART)

FIG. 1

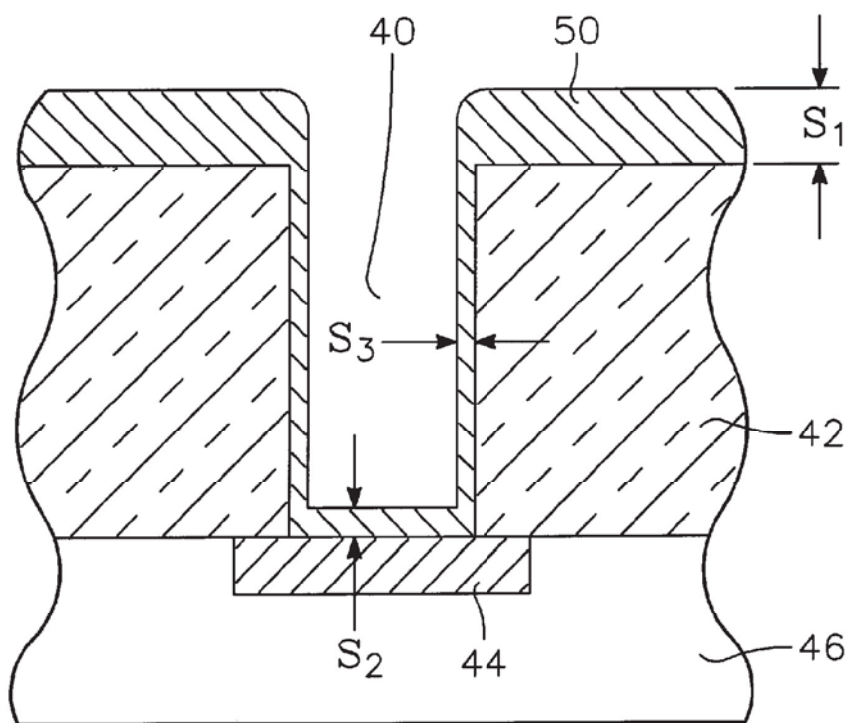

FIG. 2

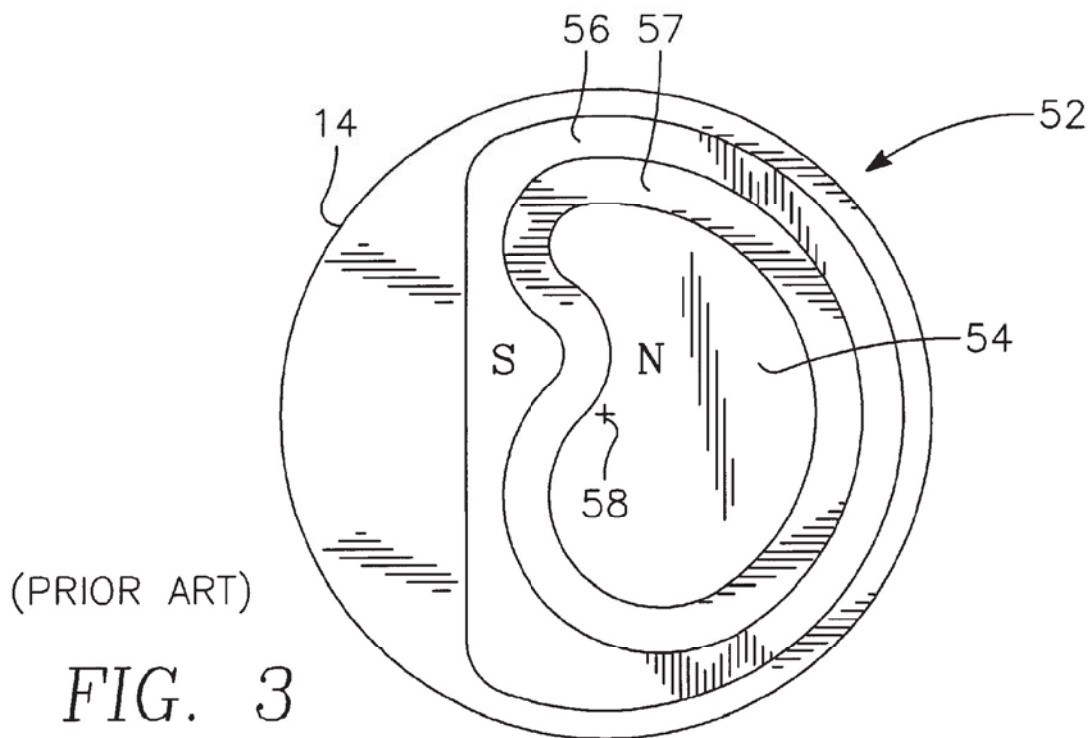

FIG. 3

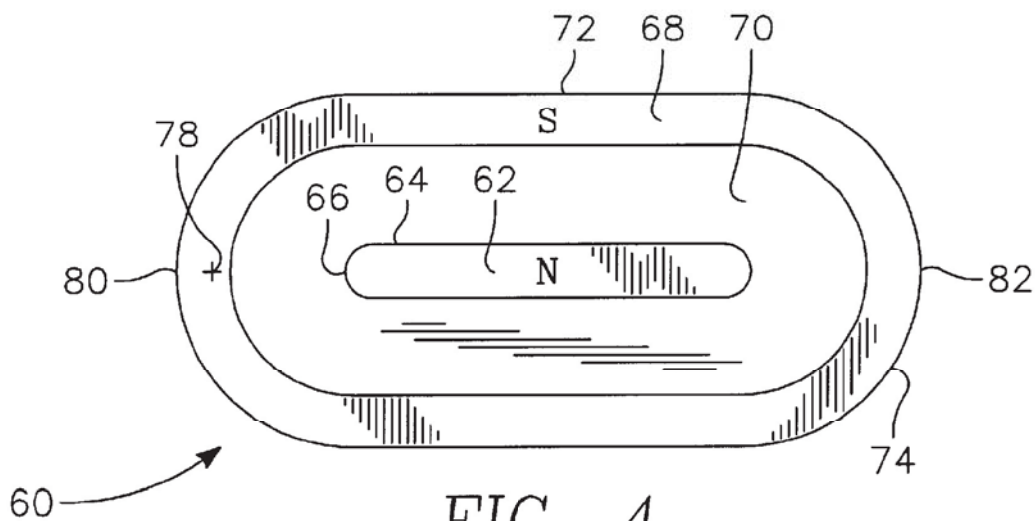

FIG. 4

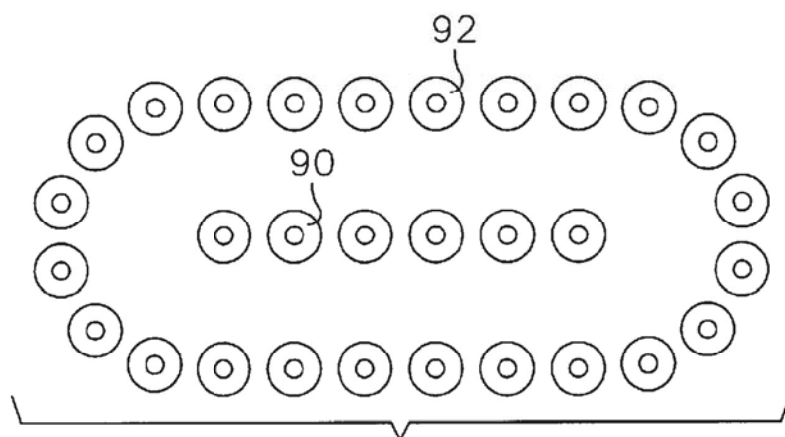

FIG. 5

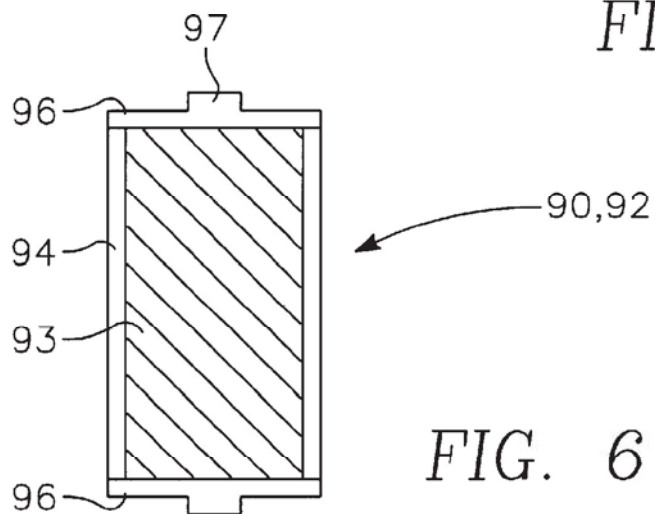

FIG. 6

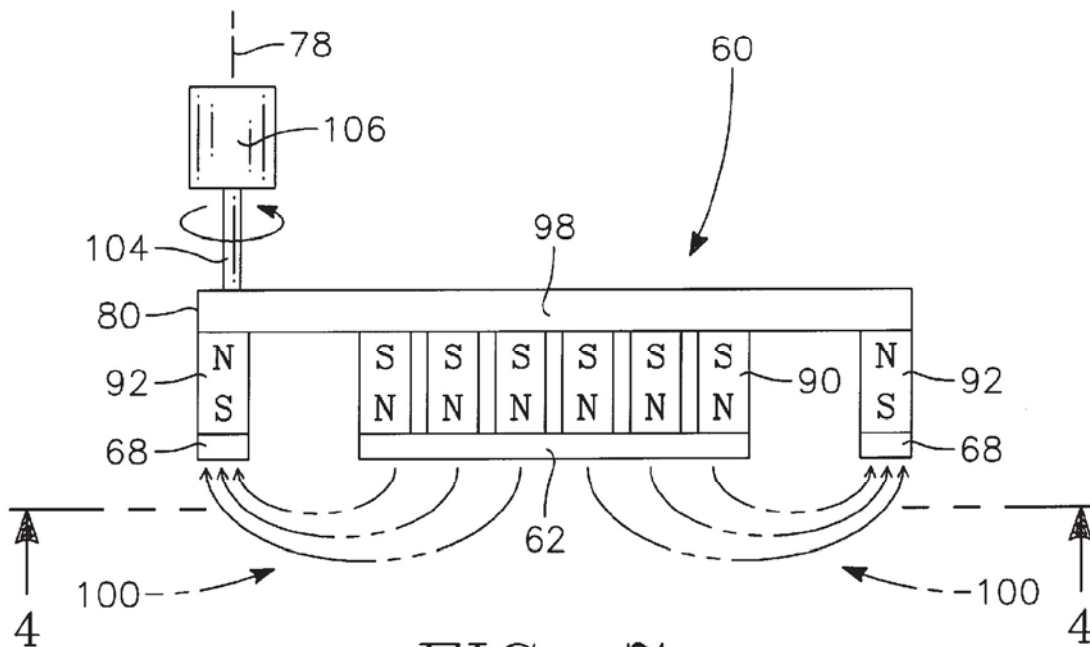

FIG. 7

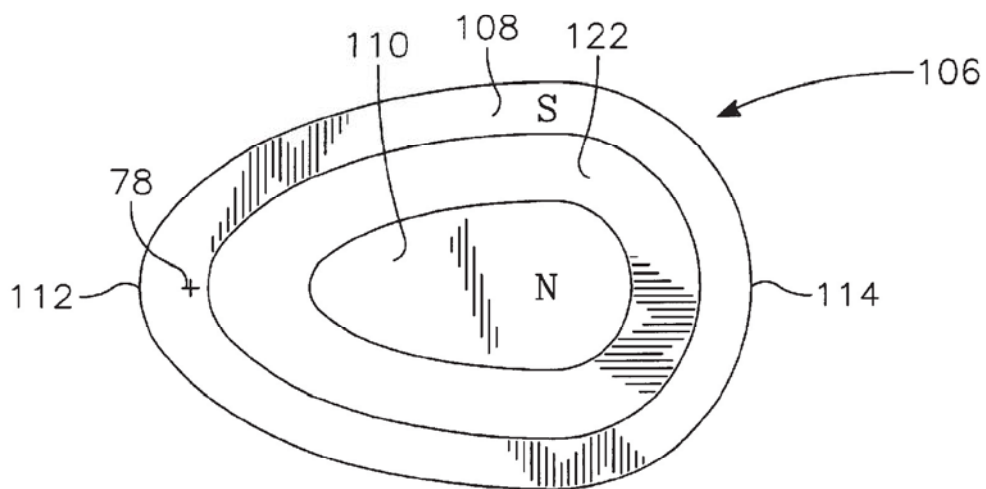

FIG. 8

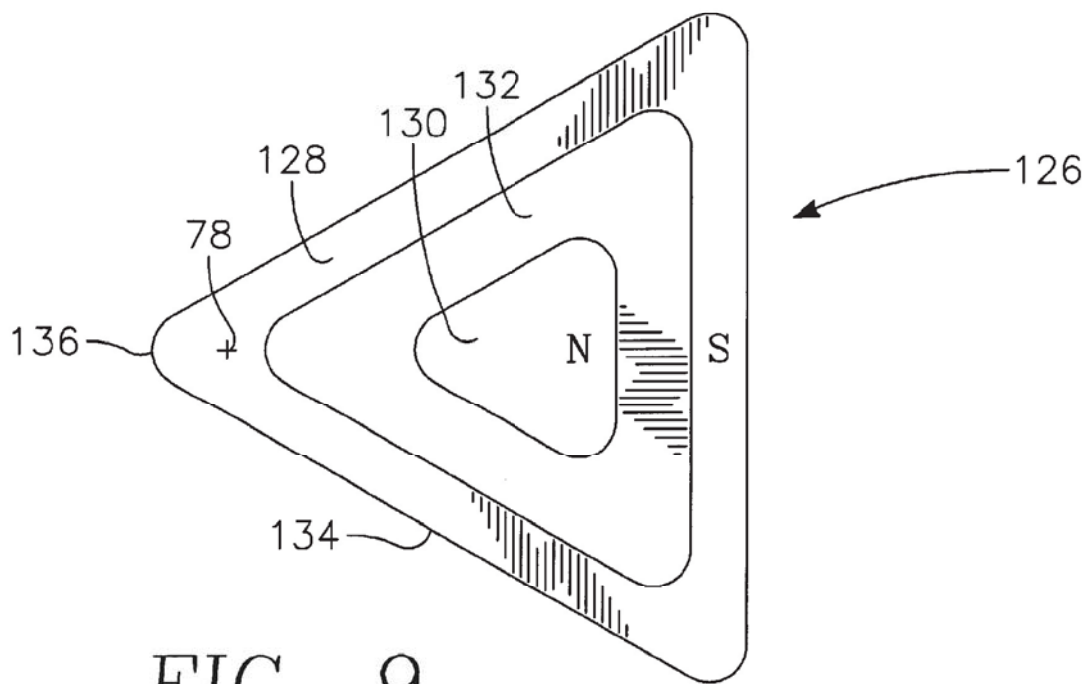

FIG. 9

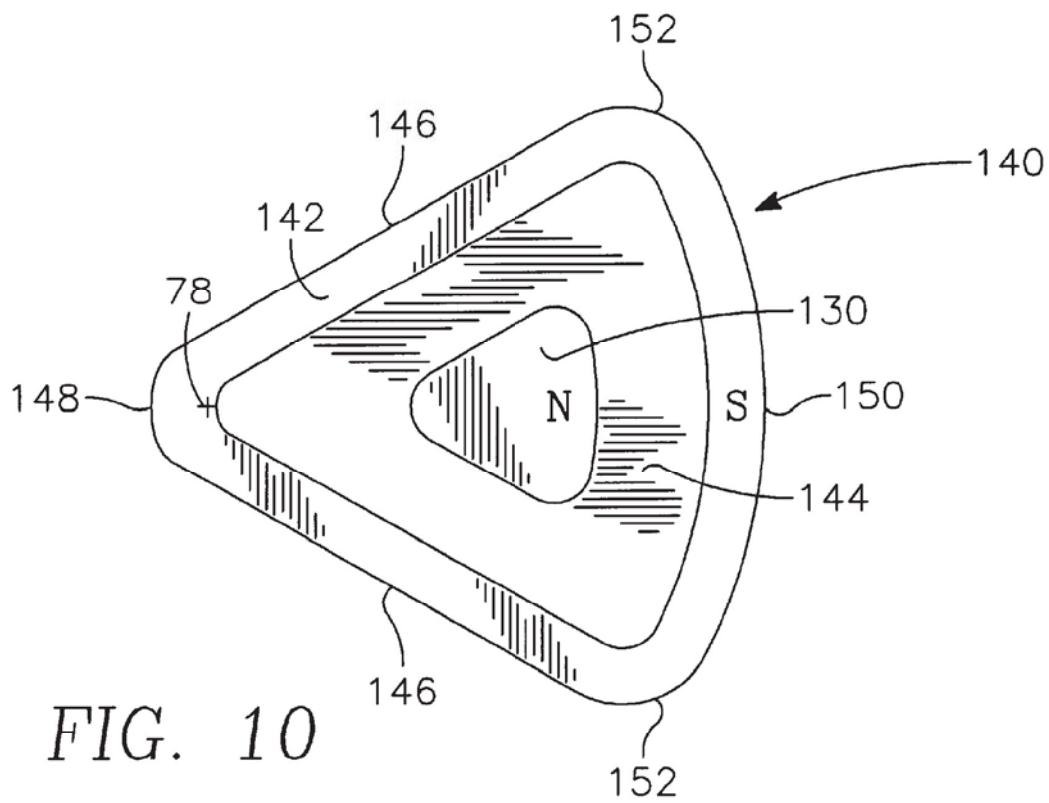

FIG. 10

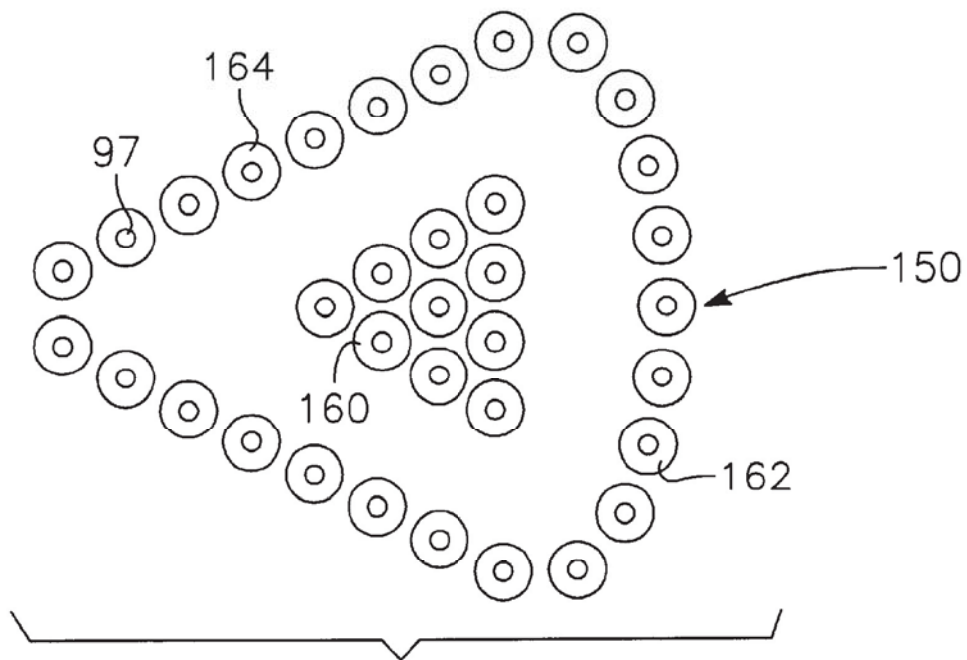

FIG. 11

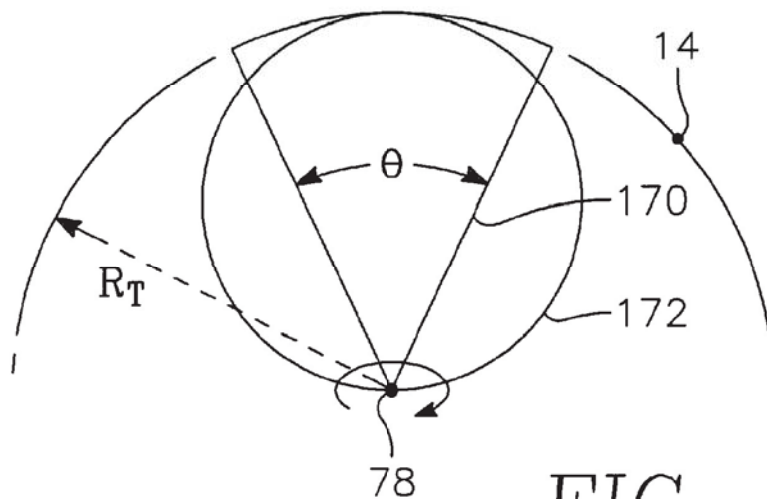

FIG. 12

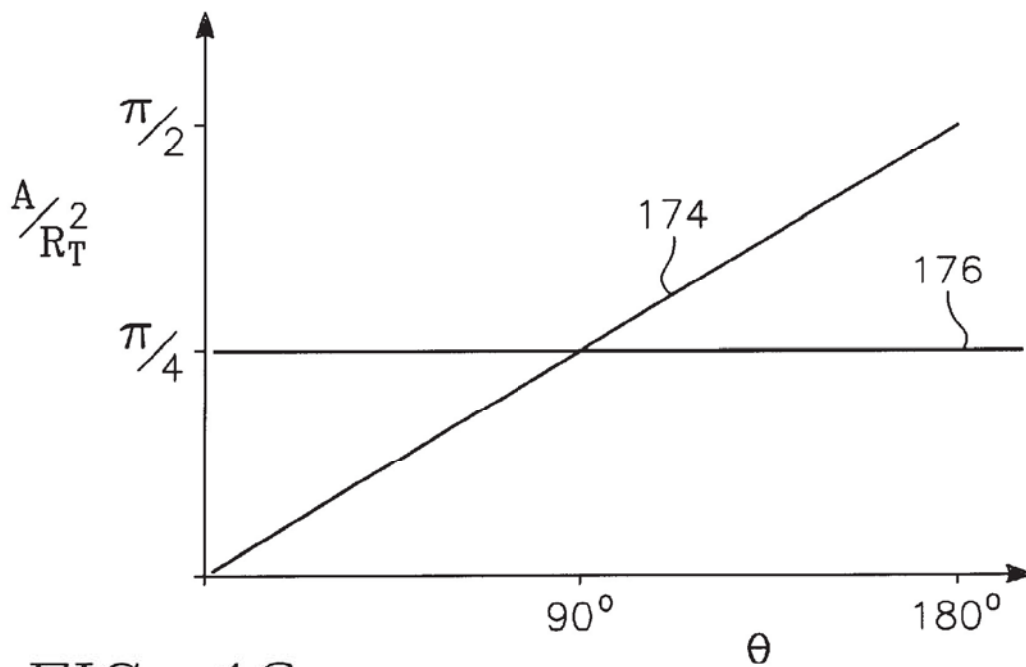

FIG. 13

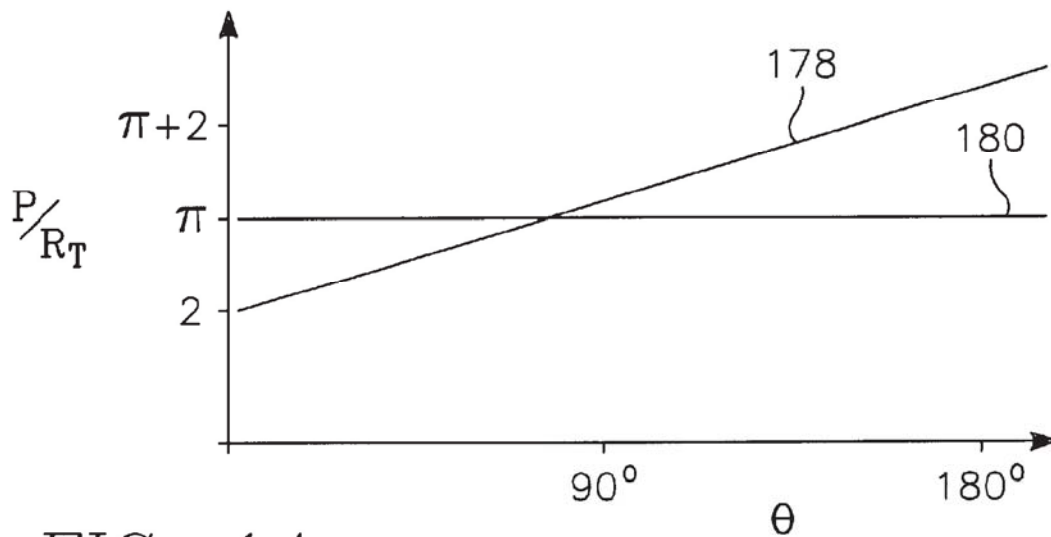

FIG. 14

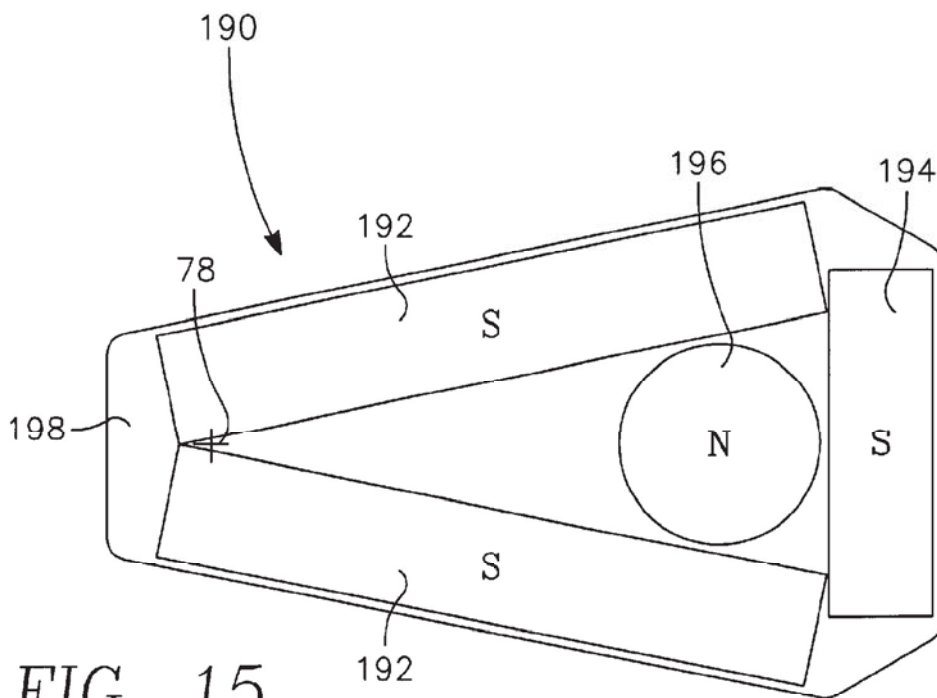

FIG. 15

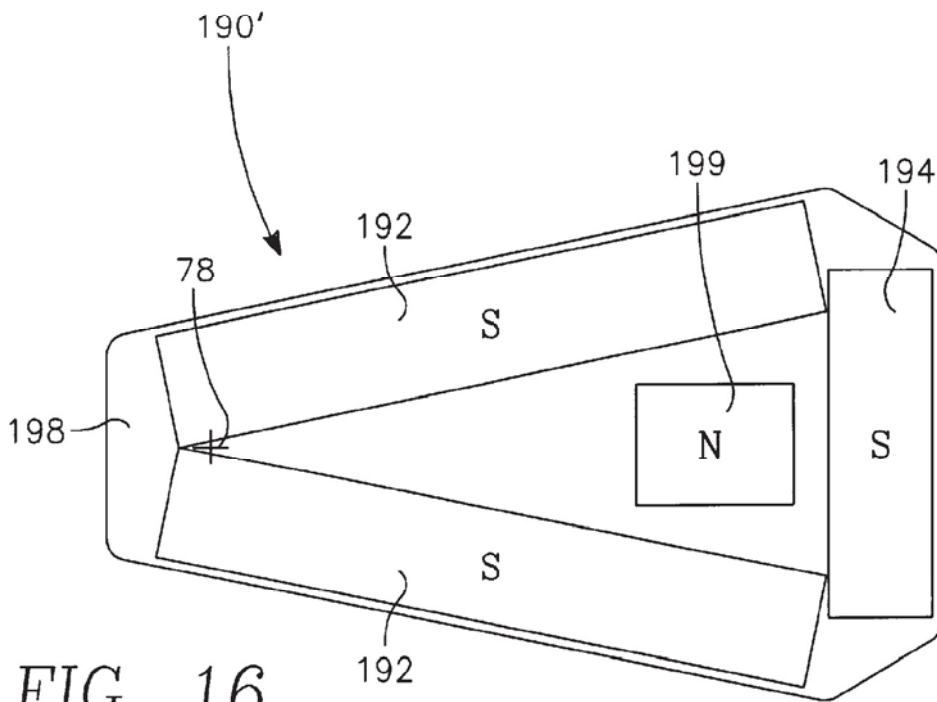

FIG. 16

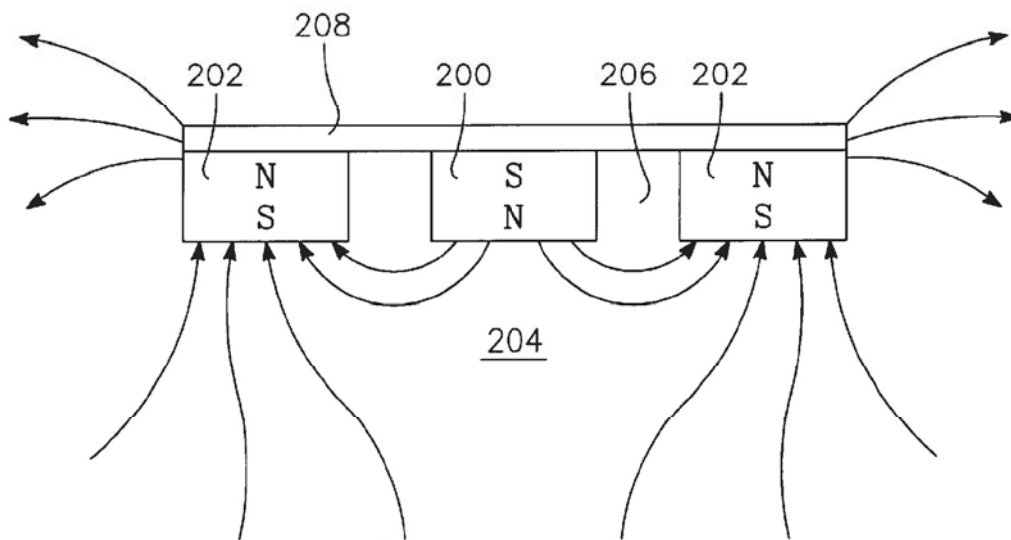

FIG. 17

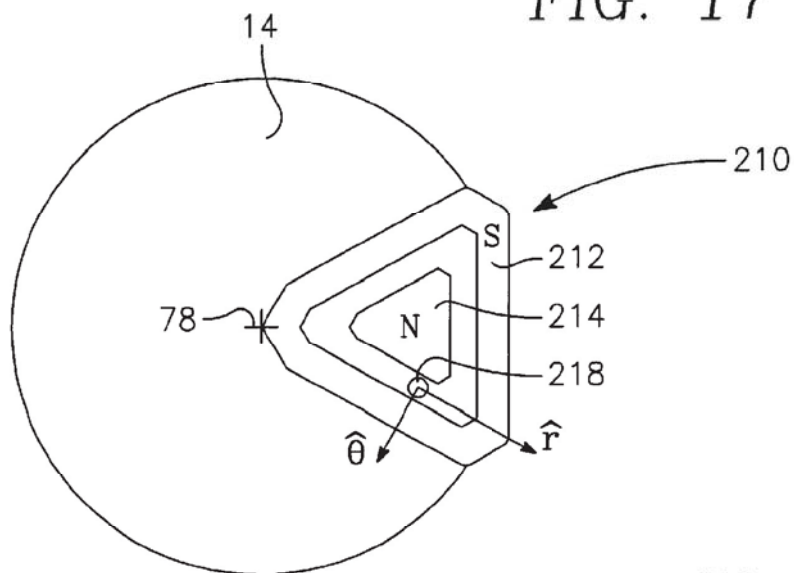

FIG. 18

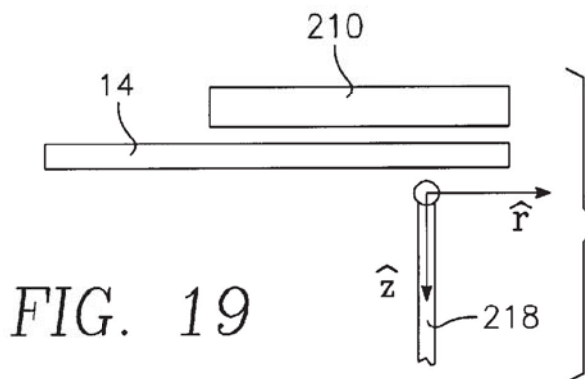

FIG. 19

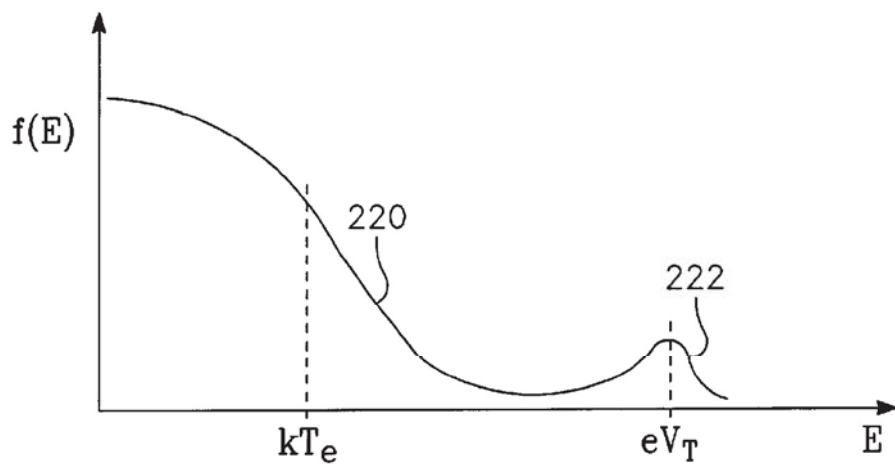

FIG. 20

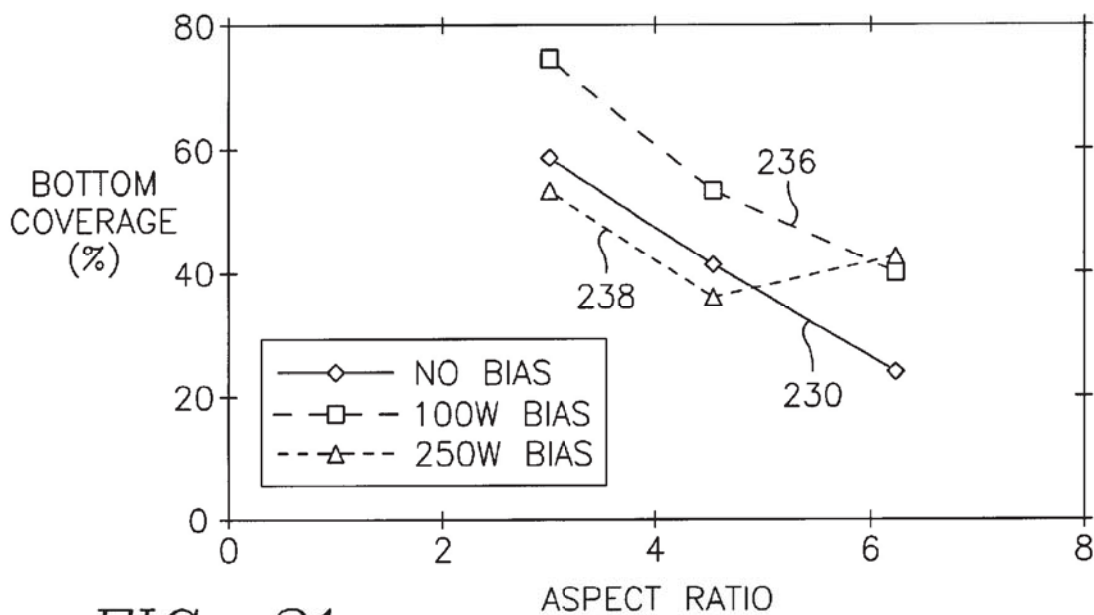

FIG. 21

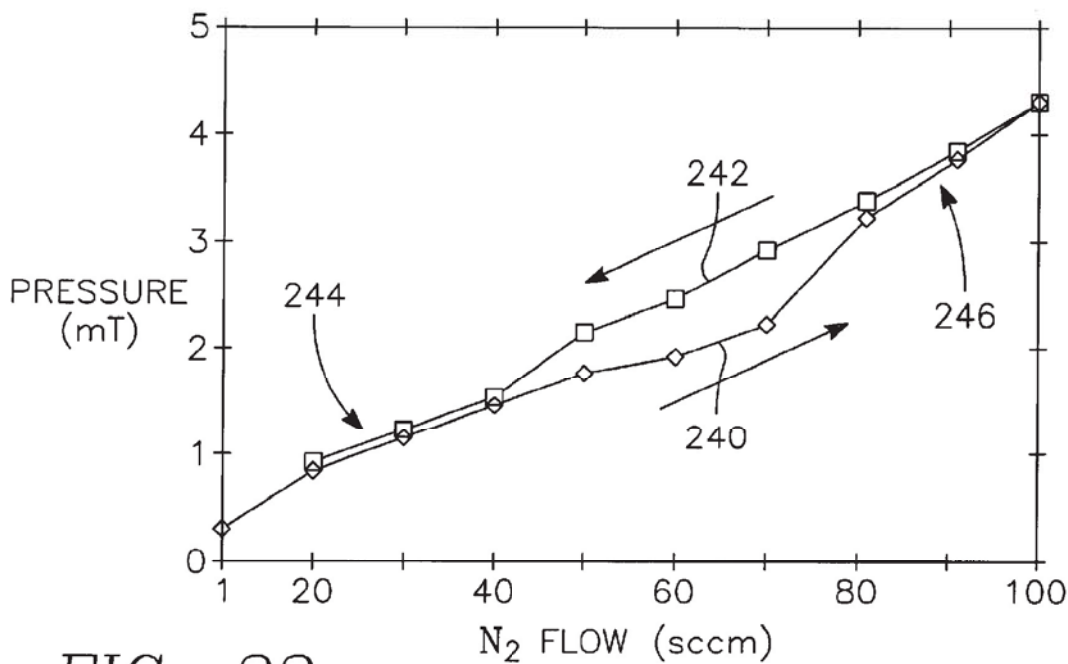

FIG. 22

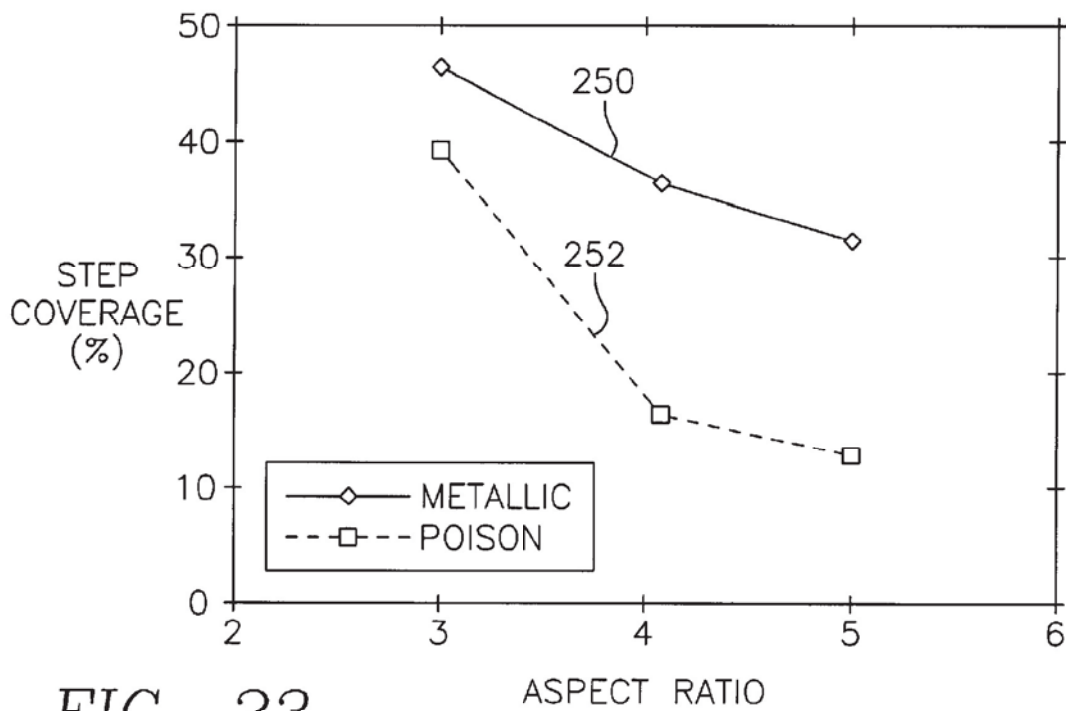

FIG. 23

HIGH-DENSITY PLASMA FOR IONIZED METAL DEPOSITION CAPABLE OF EXCITING A PLASMA WAVE

RELATED APPLICATION

This application is a continuation in part of Ser. No. 09/373,097, filed Aug. 12, 1999, now U.S. Pat. No. 6,183,614 Feb. 6, 2001 which is a continuation in part of Ser. No. 09/249,468, filed Feb. 12, 1999.

FIELD OF THE INVENTION

The invention relates generally to sputtering of materials. In particular, the invention relates to the magnetron creating a magnetic field to enhance sputtering.

BACKGROUND ART

Sputtering, alternatively called physical vapor deposition (PVD), is the most prevalent method of depositing layers of metals and related materials in the fabrication of semiconductor integrated circuits. A conventional PVD reactor **10** is illustrated schematically in cross section in FIG. 1, and the illustration is based upon the Endura PVD Reactor available from Applied Materials, Inc. of Santa Clara, California. The reactor **10** includes a vacuum chamber **12** sealed to a PVD target **14** composed of the material, usually a metal, to be sputter deposited on a wafer **16** held on a heater pedestal **18**. A shield **20** held within the chamber protects the chamber wall **12** from the sputtered material and provides the anode grounding plane. A selectable DC power supply **22** negatively biases the target **14** to about -600VDC with respect to the shield **20**. Conventionally, the pedestal **18** and hence the wafer **16** are left electrically floating.

A gas source **24** supplies a sputtering working gas, typically the chemically inactive gas argon, to the chamber **12** through a mass flow controller **26**. In reactive metallic nitride sputtering, for example, of titanium nitride, nitrogen is supplied from another gas source **27** through its own mass flow controller **26**. Oxygen can also be supplied to produce oxides such as Al_2O_3 . The gases can be admitted to the top of the chamber, as illustrated, or at its bottom, either with one or more inlet pipes penetrating the bottom of the shield or through the gap between the shield **20** and the pedestal **18**. A vacuum system **28** maintains the chamber at a low pressure. Although the base pressure can be held to about 10^{-7} Torr or even lower, the pressure of the working gas is typically maintained at between about 1 and 1000 mTorr. A computer-based controller **30** controls the reactor including the DC power supply **22** and the mass flow controllers **26**.

When the argon is admitted into the chamber, the DC voltage between the target **14** and the shield **20** ignites the argon into a plasma, and the positively charged argon ions are attracted to the negatively charged target **14**. The ions strike the target **14** at a substantial energy and cause target atoms or atomic clusters to be sputtered from the target **14**. Some of the target particles strike the wafer **16** and are thereby deposited on it, thereby forming a film of the target material. In reactive sputtering of a metallic nitride, nitrogen is additionally admitted into the chamber **12**, and it reacts with the sputtered metallic atoms to form a metallic nitride on the wafer **16**.

To provide efficient sputtering, a magnetron **32** is positioned in back of the target **14**. It has opposed magnets **34**, **36** creating a magnetic field within the chamber in the neighborhood of the magnets **34**, **36**. The magnetic field traps electrons and, for charge neutrality, the ion density also

increases to form a high-density plasma region **38** within the chamber adjacent to the magnetron **32**. The magnetron **32** is usually rotated about the center of the target **14** to achieve full coverage in sputtering of the target **14**. The form of the magnetron is a subject of this patent application, and the illustrated form is intended to be only suggestive.

The advancing level of integration in semiconductor integrated circuits has placed increasing demands upon sputtering equipment and processes. Many of the problems are associated with contact and via holes. As illustrated in the cross-sectional view of FIG. 2, via or contact holes **40** are etched through an interlevel dielectric layer **42** to reach a conductive feature **44** in the underlying layer or substrate **46**. Sputtering is then used to fill metal into the hole **40** to provide inter-level electrical connections. If the underlying layer **46** is the semiconductor substrate, the filled hole **40** is called a contact; if the underlying layer is a lower-level metallization level, the filled hole **40** is called a via. For simplicity, we will refer hereafter only to vias. The widths of inter-level vias have decreased to the neighborhood of $0.25\ \mu\text{m}$ and below while the thickness of the inter-level dielectric has remained nearly constant at around $0.7\ \mu\text{m}$. As a result, the via holes in advanced integrated circuits have increased aspect ratios of three and greater. For some technologies under development, aspect ratios of six and even greater are required.

Such high aspect ratios present a problem for sputtering because most forms of sputtering are not strongly anisotropic, a cosine dependence off the vertical being typical, so that the initially sputtered material preferentially deposits at the top of the hole and may bridge it, thus preventing the filling of the bottom of the hole and creating a void in the via metal.

It has become known, however, that deep hole filling can be facilitated by causing a significant fraction of the sputtered particles to be ionized in the plasma between the target **14** and the pedestal **18**. The pedestal **18** of FIG. 1, even if it is left electrically floating, develops a DC self-bias, which attracts ionized sputtered particles from the plasma across the plasma sheath adjacent to the pedestal **18** and deep into the hole **40** in the dielectric layer **42**. The effect can be accentuated with additional DC or RF biasing of the pedestal electrode **18** to additionally accelerate the ionized particles extracted across the plasma sheath towards the wafer **16**, thereby controlling the directionality of sputter deposition. The process of sputtering with a significant fraction of ionized sputtered atoms is called ionized metal deposition or ionized metal plating (IMP). Two related quantitative measures of the effectiveness of hole filling are bottom coverage and side coverage. As illustrated schematically in FIG. 2, the initial phase of sputtering deposits a layer **50**, which has a surface or blanket thickness of s_1 , a bottom thickness of s_2 , and a sidewall thickness of s_3 . The bottom coverage is equal to S_2/S_1 , and the sidewall coverage is equal to s_3/s_1 . The model is overly simplified but in many situations is adequate.

One method of increasing the ionization fraction is to create a high-density plasma (HDP), such as by adding an RF coil around the sides of the chamber **12** of FIG. 1. An HDP reactor not only creates a high-density argon plasma but also increases the ionization fraction of the sputtered atoms. However, HDP PVD reactors are new and relatively expensive, and the quality of the deposited films is not always the best. It is desired to continue using the principally DC sputtering of the PVD reactor of FIG. 1.

Another method for increasing the ionization ratio is to use a hollow-cathode magnetron in which the target has the

shape of a top hat. This type of reactor, though, runs very hot and the complexly shaped targets are very expensive.

It has been observed that copper sputtered with either an inductively coupled HDP sputter reactor or a hollow-cathode reactor tends to form an undulatory copper film on the via sidewall, and further the deposited metal tends to dewet. The variable thickness is particularly serious when the sputtered copper layer is being used as a seed layer of a predetermined minimum thickness for a subsequent deposition process such as electroplating to complete the copper hole filling.

A further problem in the prior art is that the sidewall coverage tends to be asymmetric with the side facing the center of the target being more heavily coated than the more shielded side facing a larger solid angle outside the target. Not only does the asymmetry require excessive deposition to achieve a seed layer of predetermined minimum thickness, it causes cross-shaped trenches used as alignment indicia in the photolithography to appear to move as the trenches are asymmetrically narrowed.

Another operational control that promotes deep hole filling is chamber pressure. It is generally believed that lower chamber pressures promote hole filling. At higher pressures, there is a higher probability that sputtered particles, whether neutral or ionized, will collide with atoms of the argon carrier gas. Collisions tend to neutralize ions and to randomize velocities, both effects degrading hole filling. However, as described before, the sputtering relies upon the existence of a plasma at least adjacent to the target. If the pressure is reduced too much, the plasma collapses, although the minimum pressure is dependent upon several factors.

The extreme of low-pressure plasma sputtering is sustained self-sputtering (SSS), as disclosed by Fu et al. in U.S. patent application, Ser. No. 08/854,008, filed May 8, 1997. In SSS, the density of positively ionized sputtered atoms is so high that a sufficient number are attracted back to the negatively biased target to resputter more ionized atoms. Under the right conditions for a limited number of target metals, the self-sputtering sustains the plasma, and no argon working gas is required. Copper is the metal most prone to SSS, but only under conditions of high power and high magnetic field. Copper sputtering is being seriously developed because of copper's low resistivity and low susceptibility to electromigration. However, for copper SSS to become commercially feasible, a full-coverage, high-field magnetron needs to be developed.

Increased power applied to the target allows reduced pressure, perhaps to the point of sustained self-sputtering. The increased power also increases the ionization density. However, excessive power requires expensive power supplies and increased cooling. Power levels in excess of 30 kW are expensive and should be avoided if possible. In fact, the pertinent factor is not power but the power density in the area below the magnetron since that is the area of the high-density plasma promoting effective sputtering. Hence, a small, high-field magnet would most easily produce a high ionization density. For this reason, some prior art discloses a small circularly shaped magnet. However, such a magnetron requires not only rotation about the center of the target to provide uniformity, but it also requires radial scanning to assure full and fairly uniform coverage of the target. If full magnetron coverage is not achieved, not only is the target not efficiently used, but more importantly the uniformity of sputter deposition is degraded, and some of the sputtered material redeposits on the target in areas that are not being

sputtered. Furthermore, the material redeposited on unsputtered areas may build up to such a thickness that it is prone to flake off, producing severe particle problems. While radial scanning can potentially avoid these problems, the required scanning mechanisms are complex and generally considered infeasible in a production environment.

One type of commercially available magnetron is kidney-shaped, as exemplified by Tepman in U.S. Pat. No. 5,320,728. Parker discloses more exaggerated forms of this shape in U.S. Pat. No. 5,242,566. As illustrated in plan view in FIG. 3, the Tepman magnetron 52 is based on a kidney shape for the magnetically opposed pole faces 54, 56 separated by a circuitous gap 57 of nearly constant width. The pole faces 54, 56 are magnetically coupled by unillustrated horseshoe magnets bridging the gap 57. The magnetron rotates about a rotational axis 58 at the center of the target 14 and near the concave edge of the kidney-shaped inner pole face 54, which is generally parallel to the gap 57 in that area, is close to the outer periphery of the usable portion of the target 14. This shape has been optimized for high field and for uniform sputtering but has an area that is nearly half that of the target. It is noted that the magnetic field is relatively weak in areas separated from the pole gap 57.

For these reasons, it is desirable to develop a small, high-field magnetron providing full coverage so as to promote deep hole filling and sustained copper self-sputtering.

SUMMARY OF THE INVENTION

The invention includes a sputtering magnetron having an oval or related shape of smaller area than a circle of equal diameter where the two diameters extend along the target radius with respect to the typical rotation axis of the magnetron. The shapes include racetracks, ellipses, egg shapes, triangles, and arced triangles asymmetrically positioned about the target center.

The magnetron is rotated on the backside of the target about a point preferably near the magnetron's thin end, and the thicker end is positioned more closely to the target periphery. Preferably, the total magnetic flux is greater outside than inside the half radius of the target.

The magnetic intensity away from the target can be increased for a triangular magnetron having a relatively small apex angle by using bar magnets.

The small area allows an electrical power density of at least 600 W/cm² to be applied from an 18 kW power supply to a fully covered sputtering target used to sputter deposit a 200 mm wafer.

The high power density and the magnetic field extending far away from the target are two means possible to produce a plasma wave which can further drive the plasma to a higher density and ionization. Advantageously, a primary plasma wave is generated at a higher frequency in the range of hundreds of megahertz, which is parametrically converted to another wave at a much lower frequency, for example, 5 to 75 MHz, corresponding to the thermal velocity of electrons in the plasma produced by capacitively coupling DC power to the target.

The magnetron is configured to produce less magnetic flux in its inner pole than in its surrounding outer pole. Thereby, the magnetic field reaches further into the sputtering chamber to promote low-pressure sputtering and sustained self-sputtering.

The invention also includes sputtering methods achievable with such a magnetron. The high magnetic field extend-

ing over a small closed area facilitates sustained self-sputtering. Many metals not subject to sustained self-sputtering can be sputtered at chamber pressures of less than 0.5 milli Torr, often less than 0.2 milli Torr, and even at 0.1 milli Torr. The bottom coverage can be further improved by applying an RF bias of less than 250 W to a pedestal electrode sized to support a 200 mm wafer. Copper can be sputtered with 18 kW of DC power for a 330 mm target and 200 mm wafer either in a fully self-sustained mode or with a minimal chamber pressure of 0.3 milli Torr or less.

The invention provides for high-power density sputtering with power supplies of reduced capacity.

The invention also includes sputtering with condition, such as a sufficiently target power and high magnetic field away from the target, that a non-linear wave-beam interaction occurs that pumps energy into plasma electrons, thereby increasing the plasma density.

BRIEF DESCRIPTION OF THE DRAWINGS

FIG. 1 is a schematic diagram of a DC plasma sputtering reactor.

FIG. 2 is a cross-sectional view of a inter-level via in a semiconductor integrated circuit.

FIG. 3 is a plan view of a conventional magnetron.

FIG. 4 is a plan view of the pole pieces of an embodiment of the magnetron of the invention taken along the view line 4—4 of FIG. 7.

FIG. 5 is a plan view of the magnets used in the magnetron of FIG. 4.

FIG. 6 is a cross-sectional view of one of the magnets used in conjunction with the embodiments of the invention.

FIG. 7 is a cross-sectional view of the magnetron of FIG. 4.

FIG. 8 is a plan view of an egg-shaped magnetron.

FIG. 9 is a plan view of a triangularly shaped magnetron.

FIG. 10 is a plan view of a modification of the triangularly shaped magnetron of FIG. 9, referred to as an arced triangular magnetron.

FIG. 11 is a plan view of the magnets used in the arced triangular magnetron of FIG. 10.

FIG. 12 is a plan view of two model magnetrons used to calculate areas and peripheral lengths.

FIG. 13 is a graph of the angular dependences of the areas of a triangular and of a circular magnetron.

FIG. 14 is a graph of the angular dependences of the peripheral lengths of the two types of magnetrons of FIG. 12.

FIG. 15 is a bottom plan view of a magnetron of the invention using bar magnets.

FIG. 16 is a bottom plan view of an alternative to the magnetron of FIG. 15.

FIG. 17 is a side view of an idealization of the magnetic field produced with the described embodiments of the invention.

FIGS. 18 and 19 are a top plan view and a schematic side view of a chamber and magnetron arranged for measuring plasma wave generated by a magnetron of the invention.

FIG. 20 is a graph of a typical energy distribution of plasma electrons.

FIG. 21 is a graph showing the effect of RF wafer bias in bottom coverage in titanium sputtering.

FIG. 22 is a graph of the dependence of chamber pressure upon nitrogen flow illustrating the two modes of deposition

obtained in reactive sputtering of titanium nitride with a magnetron of the invention.

FIG. 23 is a graph of the step coverage obtained in the two sputtering modes for reactive sputtering of titanium nitride with a magnetron of the invention.

DETAILED DESCRIPTION OF THE PREFERRED EMBODIMENTS

One embodiment of the invention is a racetrack magnetron 60, illustrated in plan view in FIG. 4. The racetrack magnetron 60 has a central bar-shaped pole face 62 of one magnetic polarity having opposed parallel middle straight sides 64 connected by two rounded ends 66. The central, bar-shaped pole face 62 is surrounded by an outer elongated ring-shaped pole face 68 of the other polarity with a gap 70 of nearly constant width separating the bar-shaped and ring-shaped pole faces 62, 68. The outer pole face 68 of the other magnetic polarity includes opposed parallel middle straight sections 72 connected by two rounded ends 74 in general central symmetry with the inner pole face 62. The middle sections 72 and rounded ends 74 are bands having nearly equal widths. Magnets, to be described shortly, cause the pole faces 62, 68 to have opposed magnetic polarities. A backing plate, also to be described shortly, provides both a magnetic yoke between the magnetically opposed pole faces 62, 68 and support for the magnetron structure.

Although the two pole faces 62, 68 are illustrated with specific magnetic polarities producing magnetic fields extending generally perpendicularly to the plane of illustration, it is of course appreciated that the opposite set of magnetic polarities will produce the same general magnetic effects as far as the invention is concerned. The illustrated assembly produces a generally semi-toroidal magnetic field having parallel arcs extending perpendicularly to a closed path with a minimal field-free region in the center. There results a closed tunnel of magnetic field forming struts of the tunnel.

The pole assembly of FIG. 4 is intended to be continuously rotated during sputter deposition at a fairly high rotation rate about a rotation axis 78 approximately coincident with the center of the target 14 of uniform composition. The rotation axis 78 is located at or near one prolate end 80 of the outer pole face 68 and with its other prolate end 82 located approximately at the outer radial usable extent of the target 14. The asymmetric placement of the rotating magnetron 60 with respect to the target center provides a small magnetron nonetheless achieving full target coverage. The outer usable periphery of the target is not easily defined because different magnetron designs use different portions of the same target. However, it is bounded by the flat area of the target and almost always extends to significantly beyond the diameter of the wafer being sputter deposited and is somewhat less than the area of the target face. For 200 mm wafers, target faces of 325 mm are typical. A 15% unused target radius may be considered as an upper practical limit. Racetrack magnetrons are well known in the prior art, but they are generally positioned symmetrically about the center of the target. In the described invention, the racetrack is asymmetrically positioned with its inner end either overlying the target center or terminating at a radial position preferably within 20% and more preferably within 10% of the target radius from the target center. The illustrated racetrack extends along a diameter of the target.

As illustrated in the plan view of FIG. 5, two sets of magnets 90, 92 are disposed in back of the pole faces 62, 68 to produce the two magnetic polarities. The combination of

the pole faces **62**, **68**, the magnets **90**, **92**, and possibly a back magnetic yoke produces two opposite magnetic poles having areas defined by the pole faces **62**, **68**. Other means may be used to achieved such poles.

The two types of magnets **90**, **92** may be of similar construction and composition producing an axially extending magnetic flux on each vertically facing end. If they are of different, magnetic composition, diameter, or length, the flux produced by different magnets may be different. A cross-sectional view of a magnet **90**, **92** is shown in FIG. 6. A cylindrical magnetic core **93** extending along an axis is composed of a strongly magnetic material, such as neodymium boron iron (NdBFe). Because such a material is easily oxidized, the core **93** is encapsulated in a case made of a tubular sidewall **94** and two generally circular caps **96** welded together to form an air-tight canister. The caps **96** are composed of a soft magnetic material, preferably SS410 stainless steel, and the tubular sidewall **96** is composed of a non-magnetic material, preferably SS304 stainless steel. Each cap **96** includes an axially extending pin **97**, which engages a corresponding capture hole in one of the pole faces **62**, **68** or in a magnetic yoke to be shortly described. Thereby, the magnets **90**, **92** are fixed in the magnetron. The magnetic core **93** is magnetized along its axial direction, but the two different types of magnets **90**, **92** are oriented in the magnetron **60**, as illustrated in the cross-sectional view of FIG. 7, so that the magnets **90** of the inner pole **62** are aligned to have their magnetic field extending vertically in one direction, and the magnets **92** of the outer pole **68** are aligned to have their magnetic field extending vertically in the other direction. That is, they have opposed magnetic polarities.

As illustrated in the cross-sectional view of FIG. 7, the magnets **90**, **92** are arranged closely above (using the orientation of FIG. 1) the pole faces **62**, **68** located just above the back of the target **14**. A magnetic yoke **98** having a generally closed shape generally conforming to the outer periphery of the outer pole face **68** is closely positioned in back of the magnets **90**, **92** to magnetically couple the two poles **62**, **68**. As mentioned previously, holes in the pole faces **62**, **68** and in the yoke **98** fix the magnets **90**, **92**, and unillustrated hardware fix the pole faces **62**, **68** to the yoke **98**.

The inner magnets **90** and inner pole face **62** constitute an inner pole of one magnetic polarity while the outer magnets **92** and the outer pole face **68** constitute a surrounding outer pole of the other magnetic polarity. The magnetic yoke **98** magnetically couples the inner and outer poles and substantially confines the magnetic field on the back or top side of the magnetron to the yoke **98**. A semi-toroidal magnetic field **100** is thereby produced, which extends through the non-magnetic target **14** into the vacuum chamber **12** to define the high-density plasma region **38**. The field **100** extends through the non-magnetic target **14** into the vacuum chamber **12** to define the extent of the high-density plasma region **38**. The magnets **90**, **92** may be of different magnetic strength. However, it is desired for reasons to be explained later that the total magnetic flux produced by the outer magnets **92** be substantially greater than that produced by the inner magnets **90**. As illustrated, the magnetron **60** extends horizontally from approximately the center of the target **14** to the edge of the usable area of the target **14**. The magnetic yoke **90** and the two pole faces **62**, **68** are preferably plates formed of a soft magnetic material such as SS416 stainless steel.

The inner prolate end **80** of the magnetron **60** is connected to a shaft **104** extending along the rotation axis **78** and

rotated by a motor **106**. As illustrated, the magnetron **60** extends horizontally from approximately the center of the target **14** to the right hand side of the usable area of the target **14**. Demaray et al. in U.S. Pat. No. 5,252,194 disclose exemplary details of the connections between the motor **106**, the magnetron **60**, and the vacuum chamber **12**. The magnetron assembly **60** should include counter-weighting to avoid flexing of the shaft **104**. Although the center of rotation **78** is preferably disposed within the inner prolate end **74** of the outer pole face **72**, its position may be optimized to a slightly different position, but one preferably not deviating more than 20%, more preferably 10%, from the inner prolate end **80** as normalized to the prolate length of the magnetron **60**. Most preferably, the inner end of the outer pole face **68** near the prolate end **80** overlies the rotation center **78**.

The racetrack configuration of FIG. 4 has the advantage of simplicity and a very small area while still providing full target coverage. As will be discussed later, the asymmetric magnetic flux of the two poles is advantageous for low-pressure sputtering and sustained self-sputtering.

The racetrack configuration of FIG. 4 can be alternatively characterized as an extremely flattened oval. Other oval shapes are also included within the invention, for example, continuously curved shapes of continuously changing diameter such as elliptical shapes with the major axis of the ellipse extending along the radius of the target and with the minor axis preferably parallel to a rotational circumference. Tabuchi illustrates a symmetric oval magnetron in Laid-open Japanese Patent Application 63-282263. This shape however has the disadvantage of a complex shape, especially for packing the magnets in the inner pole.

Another oval shape is represented by an egg-shaped magnetron **106**, illustrated in plan view in FIG. 8. It has an outer pole face **108** of one magnetic polarity surrounding an inner pole face **110** of the other polarity with a nearly constant gap **122** between them. Both pole faces **108**, **110** are shaped like the outline of an egg with a major axis extending along the radius of the target. However, an inner end **112** of the outer pole face **108** near the rotation axis **78** is sharper than an outer end **114** near the periphery of the target. The egg shape is related to an elliptical shape but is asymmetric with respect to the target radius. Specifically, the minor axis is pushed closer to the target periphery than its center. The inner pole face **110** and the gap **122** are similarly shaped. Such an egg shape places more of the magnetic flux closer to the target periphery so as to improve sputtering uniformity. Such a preferred flux distribution may be characterized with respect to the half radius of the target extending from its center to its outer usable radius. For improved uniformity, the total magnetic flux located outside the half radius is greater than that located inside the half radius, for example, by at least a 3:2 ratio, and preferably between 1.8 and 2.3. The ratio of magnetic flux outside to inside the target half radius in this configuration is about 2:1.

A related shape is represented by a triangular magnetron **126**, illustrated in plan view in FIG. 9. It has a triangular outer pole face **128** of one magnetic polarity surrounding a substantially solid inner pole face **130** of the other magnetic polarity with a gap **132** between them. The triangular shape of the inner pole face **130** with rounded corners allows hexagonal close packing of the button magnets **90**, **92** of FIG. 6. The outer pole face **128** has three straight sections **134** are preferably offset by 60° with respect to each other and are connected by rounded corners **136**. Preferably, the rounded corners **136** have smaller lengths than the straight sections **134**. One rounded corner **136** is located near the

rotation center **78** and target center, preferably within 20%, more preferably within 10% of the target radius, and most preferably with the apex portion of the outer pole face **128** overlying the rotation center **78**. The triangularly shaped inner pole piece **130** may include a central aperture, but it is preferred that the size of such an aperture be kept small to minimize the size of the central magnetic cusp.

A modified triangular shape is represented by an arced triangular magnetron **140** of FIG. **10**. It includes the triangular inner pole face **130** surrounded by an arced triangular outer pole face **142** with a gap **144** between them and between the magnets of the respective poles and with the magnetic yoke in back of the gap **144**. The outer pole face **142** includes two straight sections **146** connected to each other by a rounded apex corner **148** and connected to an arc section **150** by rounded circumferential corners **152**. The apex corner **148** is placed near the rotational center **78** and the target center, preferably within 20% and more preferably within 10% of the target radius. The arc section **150** is located generally near the circumferential periphery of the target. Its curvature may be equal to that of the target, that is, be equidistant from the center of rotation **78**, but other optimized curvatures may be chosen for an arc section concave with respect to the rotational center **78**. It is located near the target periphery within the chamber, preferably within 25% and more preferably within 15% of the radius to the periphery. Yokoyama et al. in Laid-open Japanese Patent Application 62-89864 discloses the advantage of a plurality of arced triangular magnetrons arranged symmetrically about the target center. However, plural magnetrons do not provide for a small total area and thus do not achieve a high power density for sputtering. Furthermore, the apices of the individual magnetron sections in Yokoyama et al. are located relatively far from the target center, thus producing poor sputtering uniformity except for a large number of sections.

The magnetic field is produced by an arrangement of magnets shown in plan view in FIG. **11**. Magnets **160** of a first polarity are disposed adjacent to the inner pole face **130** in an advantageous hexagonally close-packed arrangement. Magnets **162** of a second polarity are arranged adjacent to the arc section **150** of the outer pole face **142** while magnets **164** of the second polarity are arranged adjacent to the remaining portions of the outer pole face **142**. In some situations, to be described later, it is advantageous to place magnets of different intensities at different portions of the outer pole face **142**. In one embodiment, there are **10** magnets in the inner pole and **26** magnets in the outer pole, which for magnets of equal strength produces 2.6 more magnetic flux in the outer pole than in the inner pole.

The triangular magnetrons **126**, **140** of FIGS. **9** and **10** are illustrated as having apex angles θ of 60° , which facilitates promotes hexagonal close packing of the button magnets, but the apex angle can be changed, in particular decreased below 60° . However, $60^\circ \pm 15^\circ$ seems to provide superior uniformity. The apex angle significantly affects two important parameters of the magnetron of the invention, the values of its area A and its perimeter P . Some simple calculations, most easily done for the arced triangular magnetron **140**, show the general effects of changing the apex angle θ , as illustrated in plan view in FIG. **12**. A simplified or model arced triangular magnetron **170** has two straight sides extending between the center and periphery of the target **14** of radius R_T and meeting at an apex coincident with the rotation axis **78** and further includes an arc side conforming to the usable periphery of the target **14**. The area A of the simplified arced triangular magnetron **170** is $\theta R_T^2/2$, and its periphery P is $R_T(2+\theta)$, where θ is measured in radians. Also

illustrated in FIG. **12** is a model circular magnetron **172** having a radius of $R_T/2$ and having a diameter fixed to the rotation axis **78**. It has an area A of $\pi R_T^2/4$ and a periphery P of πR_T . Both magnetrons **170**, **172** provide full target coverage. The dependence of the arced triangular area A upon the apex angle θ is plotted in normalized units in FIG. **13** by line **174** and that for the circular area by line **176**. Below 90° , the triangular area is smaller. The dependence of the triangular periphery P is plotted in FIG. **14** by line **178** and that for the circular periphery by line **180**. Below 65.4° , the arced triangular periphery is smaller. Ionization efficiency is increased by minimizing the area, since the target power is concentrated in a smaller area, and is also increased by minimizing the periphery, since edge loss is generally proportional to the peripheral length. Of course, the area needs to be large enough to accommodate the magnets creating the magnetic field. Also, these calculations do not address uniformity. It is likely that the circular magnetron **170** provides reduced uniformity relative to the arced triangular magnetron **172**.

The ratio of the magnetic flux outside to inside the target half radius for the arced triangular magnetron **172** can be approximated by the lengths of the sides **170** in the two regions by $(1+\theta)$, which is 1.79 for an apex angle θ of 45° , 2.05 for 60° , 2.31 for 75° , and 2.57 for 90° .

A variation of the arced triangular arrangement of FIGS. **10** and **11** decreases the apex angle to, for example, 47° . In addition to the hexagonally close packed inner magnets **160**, one or more inner magnets are linearly arranged from the inner corner of hexagonally closed packed magnets toward the inner corner of the outer magnets **164**. The result is intermediate the racetrack magnetron and the arced triangular magnetron

The experimental work producing the process results presented below has demonstrated the advantage of a small magnetron area. If the triangular magnetron configuration of FIGS. **11** and **12** is adjusted to have significantly smaller apex angle θ with a reduced gap between the inner and outer poles, total magnetic flux produced is limited by the permeability of the magnets. Therefore, as the apex angle and gap are decreased, the magnetic field across the gap does not extend so far away from the magnetron. As a result, the high-density plasma does not extend over an increasingly shallow height in front of the target. One approach to increase the effective magnetic flux is to use bar magnets instead of button magnets. The bar magnets have a larger fill factor in the pole area so that for a given total area and a maximum magnetic permeability (per unit area of magnet), a large magnet flux is produced.

A bottom plan view of such a magnetron **190** is illustrated in FIG. **15**. Two long side bar magnets **192** and one shorter base bar magnets **194**, each of a same first vertical magnetic polarization are arranged in a triangular shape having an apex angle of, for example, 15° . By a bar magnet is meant a magnet having at least one pair of parallel sides extending in a direction perpendicular to the direction of magnetization. The illustrated magnets **192**, **194** have two pairs of parallel sides so that they are rectangular. However, it is possible that one or both ends are shaped, especially the end near the apex. A circular central magnet **196** of the opposed second vertical magnetic polarization is mostly surrounded by the bar magnets **192**, **194**. The sides of the magnets **192**, **194**, **196** opposite the target are magnetically coupled by a triangular magnetic yoke **198** although the shape of the yoke **198** is not that important as long as the yoke **198** supports the otherwise separate and disconnected magnets **192**, **194**, **196** and magnetically couples them. The rotation axis **78** for the

yoke **198** and the magnets **192, 194, 196** is located near the apex of the triangular shape. The base outer magnet **194** is located near the target periphery just outside of the intended sputtering area of the target. No separate pole face is required on the sides of the magnets facing the target since the magnets provide a fairly uniform magnetic field. The fill factor for a single line of circular magnets is $\pi/4=0.79$ compared to a bar magnet of equal width so that the bar magnet is capable of producing 20% higher total magnetic flux.

The illustrated triangular magnetron **190** has an apex angle of 23° . Other angles may be chosen, but the bar magnets seem particularly applicable when the apex angle is between 10° and 35° although apex angles of between 20° and 30° are more realistic. Also, the advantages of the bar magnets are mostly achieved by the side magnets being bar magnets. The end magnet **194** may be replaced by a magnet or magnetic pole of more complex shape. In the original implementation of the bar magnetron **190**, the button magnet has a diameter of 0.625 inch (16 mm), and the bar magnets **192, 194, 196** have widths of 1 inch (25 mm), all magnets producing the same magnetic field per unit area. In a newer version, the width of the bar magnets is being increased to 1.5 inch (38 mm).

In an alternative embodiment of a magnetron **190'** illustrated in the bottom plan view of FIG. 16, a rectangular bar magnet **199** is used as the central magnet of the second magnetic polarity. The central magnet can assume a more complex shape, for example, a corresponding but smaller triangular shape or two circular magnets of different diameters so as to better fill the interior of the outer magnets and to make the inter-pole gap more uniform. However, the illustrated configurations have been shown to be quite effective.

It is understood that the shapes described above refer to pole faces having band-like widths of area not significantly larger than the button magnets being used. The widths, particularly of the outer pole face, can be increased, perhaps even non-uniformly, but the additional width is of less effectiveness in generating the desired high magnetic field.

The shapes presented above have all been symmetric about the target radius. However, the magnetron of the invention includes asymmetric shapes, for example one radially extending side being in the form of the racetrack of FIG. 4 and the other side being oval, e.g., the egg shape of FIG. 7, or one radially extending side being oval or straight and the other side having a triangular apex between the center and periphery of the target.

All the magnetrons described above have asymmetric areas for the inner and outer poles and, assuming similar packing of similar button magnets **90, 92** or bar magnets of similar magnetic intensities, they produce asymmetric magnetic flux. In particular, the total or integrated magnetic flux J.B.dS produced by the inner pole **200**, illustrated schematically in FIG. 17, is much less than that produced by the surrounding outer pole **202**, for example, by at least a factor of 1.5 and preferably 2. All the magnetrons are also characterized as having a compact inner pole **200** surrounded by the outer pole **202**. The result is a magnetic field distribution which is very strong in the reactor processing area **204** adjacent to the gap **206** between the poles **200, 202**, but which also extends far into the processing area **204** as the magnetic field lines of the outer pole **202** close back to the magnetic yoke **208**. The substantial fraction of magnetic field extending vertically from the target deep into the processing area **204** offers many advantages. Because the

light electrons orbit around magnetic field lines, the extended magnetic field traps electrons and thus helps to support a higher-density plasma deep into the processing area **204**. By the same interaction, the magnetic field extending close and parallel to the grounded chamber shield reduces electron loss to the shield, also increasing the density of the plasma. As a result, the plasma can be supported at lower pressure or even be self-sustained. The magnetic field also partially traps heavier positive particles and thus guides ionized sputtered particles towards the wafer.

The inventive magnet also achieves a relatively high magnetic field. However, magnetic field intensity of itself is insufficient. Some conventional magnetrons, such as Demaray et al. disclose in the aforesaid patent, use a line of horseshoe magnets arranged in a kidney-shaped linear path with only a small gap between the poles of the horseshoes. As a result, a relatively high magnetic field intensity can be achieved in the area at the periphery of the kidney shape. However, the linear shape of the high magnetic field surrounds an area of substantially no magnetic field. As a result, electrons can escape to not only the exterior but also the interior of the high-field region. In contrast, the inner pole of the triangular magnetron of the invention produces a magnetic cusp of minimal area. If electrons are lost from the magnetic field on one side of the inner pole, they are likely to be captured on the other side, thus increasing the plasma density for a given power level. Furthermore, the inner pole includes a single magnetizable pole face producing a generally uniform magnetic flux. If multiple inner poles faces were used for multiple inner magnets, magnetic field lines would extend to between the inner magnets.

A further advantage of the inventive design is that one pole is formed in a closed line and surrounds the other pole. It would be possible to form a very small linearly extending magnetron with high magnetic field intensity by arranging horseshoe magnets or the like in an open ended line with the two sets of poles being closely spaced. However, the electrons could then easily escape from the open ends and decrease the density of the plasma.

It is believed that the beneficial results of the invention are achieved in large part because the oval magnetrons and magnetrons of related shapes produce a higher plasma ionization density without requiring excessive power. Nonetheless, full target coverage is achieved. In one aspect, the inventive magnetron has a relatively small area, but has a shape that allows full target coverage without radial scanning. The triangular magnetron **160** of FIG. 10 with an apex angle of 60° has an area of $\frac{1}{6}$ (0.166) of the usable target area. In contrast, if the circular magnetron **162** were used, which similarly extends from the target center to the periphery, the magnetron area is $\frac{1}{4}$ (0.25) of the target area. As a result, the power density is less for a given power supply powering a larger circular magnetron. The target overlay percentage is even higher for the Tepman magnet of FIG. 3.

The combination of small area and full coverage is achieved by an outer magnetron shape extending from the target center to its usable periphery ($\pm 15\%$) and having a transverse dimension at half the target radius of less substantially less than the target radius, that is, prolate along the target radius. The transverse dimension should be measured circumferentially along the rotation path.

The uniformity is enhanced by an oval shape that is transversely wider, with respect to the target radius, at its outer end near the target periphery than at its inner end near

the center of rotation. That is, the minor axis is displaced towards the target circumference.

The small area of the magnetron, but nonetheless providing full target coverage, allows a very high power density to be applied to the target with a reasonably sized power supply. The small area, unlike the Tepman design, has no substantial field-free region included in its interior. Some of the examples below use an 18 kW power source. For a 200 mm wafer, the magnetron extends out to a usable target diameter of about 300 mm. The effective area of the arced triangular magnetron is about one-sixth of the area associated with this larger diameter, that is, about 117 cm². Thus, the average power density of the area being sputtered at any given location of the magnetron is about 150 W/cm². Such a high power density achieved without inductive coils can support a plasma at lower argon pressure or permit sustained self-sputtering for selected metals such as copper. Even with 300 mm wafers, a 27 kW power supply in conjunction with the small magnetron of the invention scaled to the larger dimension will produce a target power density of 103 W/cm². As shown below, a power density of 76 W/cm² is sufficient for sustained self-sputtering of copper.

Wave-Beam Interaction

The magnetrons of the type described above produce an unexpectedly high metal ionization fraction, on the order of 10 to 20%. While this is below the 50 to 70% metal ionization fraction experienced in inductively coupled IMP reactors, it is still substantially higher than the less than 5% metal ionization fraction usually experienced in DC magnetron reactors. Experiments have shown that the above described magnetrons can excite several plasma waves, and it is believed that these waves increase the energy of the plasma electrons and the increased electron energy significantly increases the ionization of the sputtered metal atoms. It is known that relatively small increases in the electron energy (temperature) significantly increases plasma densities.

A series of experiments were performed using a triangular magnetron **210** illustrated in the plan view of FIG. **18** and the side view of FIG. **19** including a generally triangular outer pole **212** surrounding an inner pole **214** of the opposite magnetic polarity. The magnetron **210** is placed behind a 1.2 cm-thick planar target **216** of titanium sealed to the otherwise conventional sputter reactor of FIG. **1**. However, the magnetron **210** is not rotated during the tests, and various probes **218** are inserted from the below with the probe tip located about 1 cm below the target **216** at a position between the magnetron poles **212, 214** at about two-thirds of the target radius. Typical chamber operating conditions used during the tests are an argon gas pressure of 1.6 milli Torr and 2 kW of DC target power producing a target voltage of 455 VDC.

A spectrum analyzer having a floating cylindrical Langmuir probe as the probe reveals a double-peaked feature at about 240 MHz and 262 MHz and a broad feature at about 22 MHz. It is our interpretation, although the invention is not limited to our understanding of the invention, that the 262 MHz peak is a lower-hybrid peak ω_{LH} and that the other two peaks are produced by a non-linear parametric conversion in which the 22MHz peak has an energy ω_B and the 240 MHz sideband peak has an energy $\omega_{LH} - \omega_B$. In a parametric conversion, the wave vector is also conserved so that wave vectors for the 22 and 240 MHz peak should be related as k_B and $k_{LH} - k_B$.

A further discussion of this interpretation requires some definitions. A plasma has two plasma frequencies associated

with the electrons and the ions. In each case, the plasma frequency ω_p can be expressed as

$$\omega_p^2 = \frac{4e^2n}{m},$$

where e is the charge which is of unit value for both electrons and most plasma ions, n_p is the plasma density, and m is the mass of the electron or ion. The plasma also has two cyclotron frequencies ω_c , which can be expressed as

$$\omega_c = \frac{eB}{mc},$$

where B is the magnetic field and c is the speed of light. We estimate that the electron plasma frequency is about 3 GHz; the electron cyclotron frequency, about 1 GHz; and the ion plasma frequency, about 11 MHz.

Matsuoka et al. have disclosed observing a plasma wave in "Dense plasma production and film deposition by new high-rate sputtering using an electric mirror," *Journal of Vacuum Science and Technology A*, vol. 7, no. 4, July/August 1989, pp. 2652-57. However, they attributed the primary plasma wave to the upper hybrid mode ω_{UH} which can be represented by

$$\omega_{UH} = \sqrt{\omega_{pe}^2 + \omega_{ce}^2}.$$

This would be too high a frequency to match the observed spectrum. Instead, we believe the 262 MHz peak is associated with the lower hybrid mode ω_{LH} which is defined as

$$\omega_{LH} = \frac{\omega_{pe}}{\sqrt{1 + \frac{\omega_{pe}^2}{\omega_{ce}^2}}}.$$

Lower hybrid modes can exist with frequencies in the range of $\omega_{ce} < \omega < (\omega_{ce}, \omega_{pe})$.

We believe that the peak at 22 MHz is associated with a lower hybrid ion quasi mode that is associated with the plasma being over driven with the large amounts of power being applied to it.

The plasma waves at 240 MHz and 262 MHz, whatever their source, do not provide much heating of the electrons. As illustrated in the graph of FIG. **20**, plasma electrons have a generally maxwellian energy distribution **220** with an average energy $\langle E \rangle$ defining an electron temperature T_e . Electron temperatures in practical sputtering plasmas have been reported in the range of 3 eV to over 20 eV. The energy distribution **220** has a high sub-peak **222** associated with the secondary electrons crossing the plasma sheath with an energy generally associated with the target voltage V_T , which for our experiments is 455V.

An advantage of the parametric power conversion believed responsible for generating the 22 MHz mode is that the higher-frequency modes, such as the 240 MHz one, are more typical in plasma reactors, but its power is converted to a lower-frequency mode at less than 20% of the original frequency which is more suitable to interact with the thermalized bulk electrons.

The wave vectors k of the upper two peaks were measured using a digital oscilloscope having two probes **208** separated by $\Delta x = 0.6$ cm in the respective r, θ, z directions illustrated in FIGS. **18** and **19**. The wave vector component k_x is

calculated to be $\Delta\phi/\Delta x$, where $\Delta\phi$ is the measured phase difference between the probes. The wave vector k for the 262 MHz peak can be represented in units of cm^{-1} as

$$\vec{k} = 3.9\hat{x} + 6.3\hat{y} + 0.5\hat{z}$$

which has a magnitude k of about 7.4 cm^{-1} . The difference in wave vectors between the 240 MHz and the 262 MHz peak has been measured to have a magnitude $|\Delta k|$ of approximately 2 cm^{-1} . The error bars on most of these measured values are large, but no more than 50%.

The magnetic field vector B has been measured at a point between the probes can be expressed in units of gauss as

$$\vec{B} = 150\hat{x} + 450\hat{y} + 35\hat{z}$$

which has a magnitude of 475 gauss. The angle between the wave vector k and the magnetic field B is equal to the ratio between the perpendicular and parallel wave vectors $k_{\perp}/|k|$, which is measured to be in the range of 0.5 to 0.75.

The phase velocity v_p for a wave is given by

$$v_p = \frac{\omega}{|k|}$$

For the 262 MHz peak, the phase velocity is thus calculated from the measured wave vector as $2 \times 10^8 \text{ cm/s}$ based on the above measurement of its wave vector. This is to be compared with a velocity of $1 \times 10^9 \text{ cm}^{-1}$ for the 455 eV injected secondary electrons. That is, the freshly injected secondary electrons could easily drive the measured 262 MHz plasma wave. However, the phase velocity of the 262 MHz peak is entirely too high to effectively interact with the bulk of the thermalized electrons.

The wave vector for the 22 MHz radiation could not be adequately measured directly. However, assuming a parametric process, the wave vector difference between the 262 MHz and the 240 MHz modes (measured as 2 cm^{-1}) should equal the wave vector of the 22 MHz mode. If this is true, the phase velocity of the 22 MHz mode is approximately $6 \times 10^7 \text{ cm/s}$, which corresponds to a 10 eV electron. That is, the 22 MHz mode is well matched to couple energy into the thermalized plasma electrons, thereby increasing the average electron energy. We believe the coupling from the plasma wave to the electrons is through Landau damping.

The conditions permitting the launching of the lower hybrid mode and its parametric conversion to another mode capable of coupling to the thermalized electrons depend greatly on the magnetic configuration and strength associated with the magnetrons. The magnetrons and planar target described for this invention appear to satisfy the conditions. Other magnetrons have been tested with planar targets, but no plasma waves are observed. Apparently, the electron mirror configuration of the complexly shaped target of Matsuoka et al. fails to launch the lower hybrid mode, and they fail to report any wave lower than about 100 MHz. In view of our experience and the apparent phase velocity of the 22 MHz mode, it seems necessary that a plasma mode be excited between 5 and 75 MHz, preferably between 10 and 50 MHz, in order to pump the 1 to 20 eV plasma electrons. That is, the plasma mode has a wave phase velocity equal to a phase velocity of an electron having an energy of between 1 and 20 eV. The launching of any plasma waves seems to depend upon a magnetic field projecting far away from the target. Matsuoka et al. accomplish this by a complex hollow cathode design. The present invention accomplishes this by the unbalanced magnetic field strengths of the two poles of

the magnetron, which produces a vertical magnetic field far away from the target, as well as by driving the reactor at a high power level.

Another condition for launching a plasma wave is that the beam density of the secondary electrons emitted from the target needs to exceed a threshold. That is, the power density applied to the target must be high. The inventive magnetron reduces the magnetron area and hence allows an increased power density achievable by a given power supply while still maintaining sputtering uniformity. Nonetheless, high target power is required for a commercially sized sputter reactor.

PROCESSES

A racetrack magnetron of FIGS. 4 and 5 was tested with copper sputtering. In one configuration, six magnets **90** are placed behind the center pole face **62**, twenty-five magnets of the same strength but opposite polarity are arranged behind and around the outer pole face **68**, and the spacing between the 33 cm target and the 200 mm wafer is 190 mm. This configuration produces a deposition uniformity of $\pm 18\%$. In a second configuration, the magnets have different strengths, the stronger ones producing 30% more magnetic flux. Six strong magnets are placed behind the center pole face, and 25 weaker magnets are placed around the outer pole face. Despite the stronger inner magnets, the total magnetic flux produced by the outer magnets is greater than that produced by the inner ones. The second configuration produces an improved deposition uniformity of 8.9%. The second configuration also produces superior hole filling into a $0.5 \mu\text{m}$ -wide, $2 \mu\text{m}$ -deep via hole. For 265 nm of blanket copper, the bottom coverage is between 10 and 15%, and the sidewall coverage is about 2.8%. The deep hole filling is promoted by the small area of the racetrack magnetron producing a higher ionization density. In a third configuration, strong magnets replace some of the weaker magnets near the ends of the outer pole. This produces a somewhat better uniformity.

An arced triangular magnetron of FIGS. 10 and 11 was tested in a series of experiments with different sputtering composition. For almost all the experiments, the target was spaced between 190 and 200 mm from the wafer and the target had a diameter of 330 mm for a 200 mm wafer. Copper

For copper sputtering, uniformity is improved by using ten strong magnets **160** in the inner pole, strong magnets **162** along the arc portion **150** of the outer pole, and weaker magnets **164** for the remainder of the outer pole. The stronger magnets have a diameter 30% larger than the diameter of the weaker magnets, but are otherwise of similar composition and structure, thereby creating an integrated magnetic flux that is 70% larger.

Sustained self-sputtering of copper is achieved, after striking the plasma in an argon ambient, with 9 kW of DC power applied to the target having a usable diameter of about 30 cm, which results in a power density of 76 W/cm^2 with the arced triangular magnetron. However, it is considered desirable to operate with 18 kW of DC power and with a minimal argon pressure of about 0.1 milli Torr arising at least in part from leakage of the gas providing backside cooling of the wafer to the liquid-chilled pedestal. The increased background pressure of 0.1 to 0.3 milli Torr enhances effective wafer cooling without significant increase in the scattering and deionization of the sputtered ions. These relatively low DC powers are important in view of the ongoing development of equipment for 300 mm wafers, for which these numbers scale to 20 kW and 40 kW. A power supply of greater than 40 kW is considered expensive if not infeasible.

One application of ionized copper sputtering is to deposit a thin conformal seed layer of copper in a deep and narrow via hole. Thereafter, electro or electroless plating can be used to quickly and economically fill the remainder of the hole with copper.

In one experiment, a via hole having a top width of 0.30 μm and extending through 1.2 μm of silica was first coated with a Ta/TaN barrier layer. Using the arced triangular magnetron, copper was deposited over the barrier layer at 18 kW of target power and a pressure of 0.2 milli Torr. The deposition was carried out to a blanket thickness of about 0.15 μm . The sides of the via hole was smoothly covered. The experiments show that the sidewall thickness of the copper is about 7 nm on one side and 11.4 nm on the other side (5% and 8%) for a via located at the wafer edge. The bottom coverage is about 24 nm (16%). Sidewall symmetry is improved for a via hole at the wafer center. The smoothness promotes the use of the deposited layer as a seed layer and as an electrode for subsequent electroplating of copper. The relatively good symmetry between the two sidewalls relieves the problem in the prior art of apparently moving photolithographic indicia.

Aluminum

Using the arced triangular magnetron, sputtering of an aluminum target was achieved at both 12 kW and 18 kW of applied power with a minimum pressure of about 0.1 milli Torr, a significant improvement. For aluminum sputtering, sidewall coverage and particularly bottom coverage is significantly improved. The better uniformity is also believed to be related in part to the increased ionization fraction since the self-biased pedestal supporting the wafer attracts the ionized sputtered particles across its entire area. It is estimated that the magnetron of the invention increases the ionization fraction from 2% to at least 20% and probably 25%.

The arced triangular magnetron was compared under similar operating conditions to the operation of a conventional magnetron resembling the Tepman magnetron of FIG. 3. The comparative results are summarized in TABLE 1 for the sputtering of aluminum.

TABLE 1

	Triangle	Conv.
Bottom Coverage	28.5%	8.0%
Sidewall Coverage	8.0%	5.7%
Uniformity (190 mm)	4.6%	7.8%
Uniformity (290 mm)	3.0%	6.0%
Minimum Pressure (milli Torr)	0.1	0.35

The coverage results were obtained for via holes having a width of 0.25 μm and a depth of 1.2 μm , that is, an aspect ratio of about 5. The bottom coverage is significantly improved with the inventive triangular magnetron compared to the conventional magnetron. The sidewall coverage is also increased, and further the coverage is smooth and uniform from top to bottom. These two characteristics promote the use of the deposited metal layer as a seed layer for a subsequent deposition step. This is particularly important for copper in which the second deposition is performed by a different process such as electroplating. The increased bottom and sidewall coverages are believed to be due to the higher ionization fraction of sputtered aluminum atoms

achieved with the inventive triangular magnetron. This ionization fraction is believed to be 25% or greater. The uniformity of blanket (planar) deposition was determined both for a separation of 190 mm between the target and the wafer and, in a long-throw implementation, for a separation of 290 mm. The inventive triangular magnetron produces better uniformity, especially for long throw. The better uniformity is also believed to be related to the increased ionization fraction since the self-biased pedestal supporting the wafer attracts the ionized sputtered particles across its entire area. Similarly, the inventive triangular magnetron produces less asymmetry between the coverages of the two opposed sidewalls. The increased ionization density is due in part to the relatively small inner yoke having an area substantially less than that of the outer yoke. As a result, electrons lost from one side of the inner yoke are likely to be captured by the other side.

The bar magnetron of FIG. 15 has been demonstrated for sputtering copper. It shows improved bottom coverage and sidewall coverage near the bottom. Overall, it produces a seed layer of reduced thickness that still allows effective hole filling of copper by electrochemical plating.

All of these advantages are obtainable in a conventional capacitively coupled DC sputter reactor using a magnetron of fairly simple design. Of course, the magnetron of the invention can also be advantageously used in other types of sputter reactors, such as an HDP reactor relying upon inductively coupled RF power.

Titanium

The arced triangular magnetron was also used to sputter titanium. Titanium, sometimes in conjunction with titanium nitride, is useful in aluminum metallization for providing a silicided contact to silicon at the bottom of a contact hole and to act as wetting layer and in conjunction with a titanium nitride layer as a barrier both to the silicon in a contact hole and between the aluminum and the silica dielectric on the via or contact sidewalls. Conformal and relatively thick coatings are thus required.

A series of experiments were performed using a titanium target with 18 kW of DC target power and with only six magnets 160 in the inner pole. At a chamber pressure of 0.35 milli Torr, the bottom coverage and uniformity are observed to be good.

The titanium experiments were continued to measure bottom coverage as a function of the aspect ratio (AR) of the via hole being coated. With no wafer bias applied and the pedestal heater 18 left electrically floating, the 18 kW of target power nonetheless self-biases the target to about 30 to 45V. The bottom coverage under these conditions is shown by line 230 in the graph of FIG. 21. The bottom coverage decreases for holes of higher aspect ratios but is still an acceptable 20% at AR=6.

In a continuation of these experiments, an RF power source 232, illustrated in FIG. 1, was connected to the heater pedestal 18 through a capacitive coupling circuit 234. It is known that such an RF field applied to the wafer adjacent to a plasma creates a DC self-bias. When 100W of 400 kHz power is applied with a chamber pressure of 0.3 milli Torr, the bottom coverage is significantly increased, as shown by line 236 in the graph of FIG. 21. However, when the bias power is increased to 250 W, resputtering and faceting of the top corners of the via hole becomes a problem. The bottom coverage results for 250 W bias are shown by line 238. For aspect ratios above 4.5, the bottom coverage with 250 W of wafer bias is generally worse than for 100W of wafer bias so bias powers should be kept below 250 W for lower bias frequencies of 2MHz or less. These powers should be

normalized to a 200 mm circular reference wafer. Other sizes of wafers, such as a 300 mm wafer can be used, and these wafers may not be completely circularly because of indexing flats or notches. However, the same effects are expected when the power levels quoted above are referenced to a 200 mm circular reference wafer and then scaled according to the differing area of a substantially circular working wafer.

The experiments were continued for holes with aspect ratios of 4.5 using 300 W of RF wafer bias at a frequency of 13.56 MHz. At a pressure of 0.7 milli Torr, the blanket deposition rate is 128 nm/min, and the bottom coverage varies between 31% and 2%. At a pressure of 1.4 milli Torr, the deposition rate is 142 nm/min, and the bottom coverage varies between 42% and 62%. At the higher pressure, the sidewall coverage varies between 10.4% and 11.5%, and no appreciable sidewall asymmetry is observed. Contrary to expectations, pressures above 0.7 milli Torr produce higher titanium deposition rates and better bottom coverage. The higher bias frequency permits a higher bias power to be applied.

Titanium Nitride

The magnetron of the invention can also be used for reactive sputtering, such as for TiN, in which nitrogen is additionally admitted into the chamber to react with the sputtered metal, for example, with titanium to produce TiN or with tantalum to produce TaN. Reactive sputtering presents a more complex and varied chemistry. Reactive sputtering to produce TiN is known to operate in two modes, metallic mode and poison mode. Metallic mode produces a high-density, gold-colored film on the wafer. Poison mode, which is often associated with a high nitrogen flow, produces a purple/brown film which advantageously has low stress. However, the poison-mode film has many grain boundaries, and film defects severely reduce chip yield. Furthermore, the deposition rate in poison mode is typically only one-quarter of the rate in metallic mode. It is generally believed that in poison mode the nitrogen reacts with the target to form a TiN surface on the Ti target while in metallic mode the target surface remains clean and TiN forms only on the wafer.

The arced triangular magnetron was tested for reactive sputtering of titanium nitride in the same chamber used for sputter depositing titanium.

The initialization conditions for sputter depositing titanium nitride are found to be very important to obtain operation in the metallic mode. In a series of initial experiments, argon alone is first admitted to the chamber. After the plasma is struck at an argon pressure of about 0.5 milli Torr, the argon flow is reduced to 5 sccm producing a pressure of 0.3 milli Torr. When the nitrogen flow is then step wise ramped up to 100 sccm and then is gradually reduced, the dependence of the chamber pressure upon the flow assumes a hysteric form illustrated in FIG. 18. Between about 50 and 70 sccm of nitrogen, intermediate ramp-up pressures 240 are below corresponding intermediate ramp-down pressures 242. At lower pressures 244 and at higher pressures 246, there is no significant separation between ramp up and ramp down. It is believed that the lower pressures 244 and intermediate ramp-up pressures 240 cause sputtering in metallic mode while higher pressures 246 and intermediate ramp-down pressures 242 cause sputtering in poison mode.

These results show that, for higher operational deposition rates in the generally preferred metallic mode, it is important to not exceed the intermediate ramp-up pressures 240, that is, not to exceed the maximum metallic-mode flow, which in these experiments is 70 sccm or slightly higher but definitely

below 80 sccm. The argon and nitrogen can be simultaneously and quickly turned on, but preferably the DC power is also quickly turned on.

There are some applications, however, where operation in poison mode is preferred. This can be achieved by first going to the higher pressures 246 and then decreasing to the ramp-down intermediate pressures 242. Alternatively, poison mode can be achieved by immediately turning on the desired gas flow, but only gradually turning on the DC sputtering power supply at a rate of no more than 5 kW/s.

Titanium nitride was sputtered into high aspect-ratio via holes in both metallic and poison modes at a N₂ flow of 50 sccm and an Ar flow of 5 sccm after the plasma had been struck in argon. These flows produce a pressure of 1.7 milli Torr in metallic mode and 2.1 milli Torr in poison mode. The deposition rates are 100 nm/min in metallic mode and 30 nm/min in poison mode. On one hand, the TiN film stress is higher when it is deposited in metallic mode, but on the other hand poison mode suffers from overhang and undulatory sidewall thicknesses near the top of the via hole. A series of experiments deposited TiN into via holes of differing aspect ratios. The resulting measured bottom coverage, illustrated in the graph of FIG. 23, shows in line 250 that bottom coverage in metallic mode remains relatively high even with an via aspect ratio of 5 while in line 252 the step coverage in poison mode is always lower and drops dramatically for aspect ratios of four and higher. However, when additionally the wafer is biased, step coverage of TiN deposited in the poison mode is acceptable.

The success of depositing TiN in the same chamber used for depositing Ti demonstrates that the Ti/TiN barrier can be deposited according to the invention in one continuous operation.

Integrated Tungsten Plug Process

Two series of tests were performed to demonstrate an integrated process combining the Ti/TiN barrier deposited with the arced magnetron of the invention and a tungsten plug deposited by chemical vapor deposition (CVD) into the barrier-coated hole. This combination has presented some problems in the past because tungsten CVD typically uses tungsten hexafluoride (WF₆) as the gaseous precursor. WF₆ tends to attack Ti and to result in structures formed in the W plug resembling volcanoes, which produces voids in the plug.

In the first series of tests, the barrier layer consisted of 30 nm of Ti covered by 30 nm of TiN deposited with the arced magnetron of the invention in an otherwise conventional non-inductive sputter reactor. Following the Ti/TiN deposition, the chip was subjected to rapid thermal processing (RTP) in which intense radiant lamps quickly heat the wafer surface for a short period. In the second series of tests, the barrier layer consisted of 30 nm of Ti covered by 10 nm of TiN deposited as in the first series. However, in the second test, before the Ti/TiN deposition the wafer was subjected to a plasma pre-clean, but there was no RTP afterwards. In either case, tungsten was then CVD deposited over the Ti/TiN.

These experiments show that neither process produces volcanoes. Furthermore, thickness and resistivity of the TiN show good uniformity. The TiN resistivity is measured to be less than 45 μΩ-cm. Bottom coverage of 20% for the TiN/Ti bilayer is observed in holes having aspect ratios of 5:1 without the use of wafer biasing. Wafer biasing produces the same bottom coverage in holes having aspect ratios of 10:1. Thus, the Ti/TiN process performed with the magnetron of the invention can be successfully integrated into a tungsten

plug process. The inventive magnetron can also be used to sputter deposit other materials, for example, W, using a tungsten target, or TaN, using a tantalum target and nitrogen gas in the plasma. Reactive sputtering of WN is also contemplated.

The magnetron of the invention is thus efficient in producing a high ionization fraction because of the high-density plasma it can create without excessive power being required. Nonetheless, its full coverage allows for uniform deposition and full target utilization. Its sputtering uniformity is good. Nonetheless, no complex mechanisms are required.

The effectiveness of the magnetron of the invention in providing high-performance full-coverage sputtering is based on three interrelated synergetic effects. The magnetron has a small magnetic area. Thereby, the average magnetic field can be made high, and the plasma losses reduced. The small magnetron also allows a high average power density to be applied to the area of the target beneath the magnetron. That is, although the electrical power applied to the target as a whole is relatively modest, the electrical power density and resulting plasma density in the area actually being sputtered at any instant is high. The asymmetry of the inner and outer magnetic poles of the magnetron produces portions of the magnetic field extending vertically surrounding the periphery of the magnetron and extending far into the chamber. This magnetic field distribution reduces plasma losses and guides ionized sputtered particles to the substrate. All of these advantages are enjoyed in a magnetron providing full coverage sputtering of the target with only circumferential scanning, and in a magnetron that can be optimally shaped to produce uniform target sputtering and uniform substrate deposition.

Such a small, high-field magnet enables sustained self-sputtering with relatively modest target power and also enables sputtering of materials such as aluminum and titanium at reduced pressures below 0.5 milli Torr, preferably below 0.2 milli Torr, and even at 0.1 milli Torr. At these pressures, deep hole filling can be facilitated by the reduced scattering of sputtered particles, whether neutral or ionized, and by the reduced neutralization of ionized particles. However, at least for titanium, it has been found that with the use of the magnetron of the invention, deposition rate and bottom coverage are improved with working gas pressures above 0.7 milli Torr. The high-field magnet further promotes a high ionization fraction, which can be drawn into a deep, narrow hole by biasing of the wafer within proper ranges.

What is claimed is:

1. A magnetron assembly positionable at a backside of a sputtering target and rotatable about a center position of said target, comprising a single magnetron asymmetrically disposed about said center position and including:

a first pole of a first magnetic polarity comprising first magnets of a first magnetic polarity arranged in a triangular shape, at least two of said first magnets being bar magnets arranged on long sides of said triangular shape and being inclined to each other by between 10° and 35°; and

a second pole of a second magnetic polarity disposed inside of said triangular shape and separated from said first magnets by a gap extending along a surface of said target.

2. The magnetron assembly of claim 1, wherein said angle is between 20° and 30°.

3. The magnetron assembly of claim 1, wherein said first magnets include a third bar magnet arranged adjacent to a diverging end of said two of said first magnets.

4. The magnetron assembly of claim 3, wherein said first magnets are all rectangularly shaped.

5. The magnetron assembly of claim 1, wherein said second pole includes a single second magnet.

6. The magnetron assembly of claim 5, wherein said second magnet is a bar magnet.

7. The magnetron assembly of claim 5, wherein said second magnet is circular.

8. The magnetron assembly of claim 5, wherein said first and second magnets face said target without a magnetic pole face therebetween.

9. The magnetron assembly of claim 1, further comprising a magnetic yoke disposed on a side of said first and second magnets opposite said target.

10. The magnetron assembly of claim 1 incorporated into a plasma sputtering system having a DC power supply connected to said target, wherein a level of DC power supplied to said target is sufficiently high to generate a first plasma wave that is converted into a second plasma wave having a frequency between 5 and 75 MHz.

11. The magnetron assembly of claim 10, wherein said frequency is between 10 and 50 MHz.

12. The magnetron assembly of claim 10, wherein said first plasma wave is a lower hybrid mode.

13. A DC plasma sputter reactor, comprising:
a vacuum chamber having a substantially circular target with a substantially planar central portion facing a substrate to be sputter coated;
a DC power supply negatively biasing said target with respect to said chamber;
a magnetron comprising a first pole of a first magnetic polarity substantially enclosing a second pole of a second magnetic polarity, said first and second poles being rotatable as a unit about a center of said target, said magnetron being disposed on a side of said target opposite said substrate;
wherein a level of power supplied by said DC power supply to said target is sufficiently high to generate a first plasma wave that is converted into a second plasma wave having a frequency between 5 and 75 MHz.

14. The reactor of claim 13, wherein said frequency is between 10 and 50 MHz.

15. The reactor of claim 13, wherein said first plasma wave is a lower hybrid mode.

16. The reactor of claim 13, wherein a phase velocity of said second plasma wave equals a phase velocity of an electron having an energy of between 1 and 20 eV.

17. A method of sputtering, comprising the steps of:
providing a sputtering target having a planar central portion sealed to a plasma reaction chamber;

rotating a magnetron about a center of said target, said magnetron having an inner pole of one magnetic polarity surrounded by a magnetically stronger outer pole of a second magnetic polarity;

DC biasing said sputtering target with respect to chamber to create a plasma within said chamber to thereby sputter said target, said DC biasing being sufficiently strong to launch a first plasma wave of a first frequency; converting said first plasma wave to a second plasma wave of a second frequency of less than 20% of said first frequency; and

interacting said second plasma wave with electrons of said plasma.

18. The method of claim 17, wherein said electrons have energies in a range of 1 to 20 eV and said second plasma wave has a phase velocity equal to at least some of said electrons.

23

- 19. The method of claim 17, wherein said converting step is a parametric conversion step.
- 20. The method of claim 17, wherein said first plasma wave is a lower hybrid wave.
- 21. The method of claim 17, wherein said magnetron is an unbalanced magnetron having sufficient magnetic strength in conjunction with said DC biasing to launch said first plasma wave that is converted to said second plasma wave.
- 22. A DC plasma sputter reactor, comprising:
 - a vacuum chamber having a substantially circular target with a substantially planar central portion facing a substrate to be sputter coated;
 - a DC power supply negatively biasing said target with respect to said chamber;
 - an unbalanced magnetron comprising a first pole of a first magnetic polarity substantially enclosing a second pole

24

of a second magnetic polarity, a total magnetic flux of said first pole being at least 150% of a magnetic flux of said second pole, said second pole having no aperture therein, said first and second poles being rotatable as a unit about a center of said target, said magnetron being disposed on a side of said target opposite said substrate and rotating about a center thereof;

wherein a level of power supplied by said DC power supply to said target is sufficiently high and said unbalanced magnetron produces a magnetic configuration with a sufficient magnetic strength to generate a first plasma wave that is converted into a second plasma wave having a frequency between 5 and 75 MHz.

* * * * *