

**EXHIBIT G.06**  
**U.S. Patent No. 7,808,184**

References cited herein:

- U.S. Patent No. 7,808,184 (“‘184 Patent”)
- U.S. Pat. No. 6,413,382 (“Wang”)
- A. A. Kudryavtsev, *et al.*, Ionization relaxation in a plasma produced by a pulsed inert-gas discharge, Sov. Phys. Tech. Phys. 28(1), January 1983 (“Kudryavtsev”)
- D.V. Mozgrin, *et al.*, High-Current Low-Pressure Quasi-Stationary Discharge in a Magnetic Field: Experimental Research, Plasma Physics Reports, Vol. 21, No. 5, 1995 (“Mozgrin”)
- Leipold et al., High-electron density, atmospheric pressure air glow discharges, Power Modulator Symposium, 2002 and 2002 High-Voltage Workshop. Conference Record of the Twenty-Fifth International, June 2002 (“Leipold”)
- Gudmundsson et al., Evolution of the electron energy distribution and plasma parameters in a pulsed magnetron discharge, Applied Physics Letters, 78(22) May 2001 (“Gudmundsson”)

Claims 8 and 18	Wang in view of Kudryavtsev and Mozgrin
1. A method of generating a strongly-ionized plasma, the method comprising:	<p>The combination of Wang and Kudryavtsev discloses a method of generating a strongly-ionized plasma.</p> <p>Wang at 7:17-31 (“The background power level <math>P_B</math> is chosen to exceed the minimum power necessary to support a plasma... [T]he application of the high peak power <math>P_P</math> quickly causes the already existing plasma to spread and increases the density of the plasma.”).</p> <p>Wang at 7:19-22 (“Preferably, the peak power <math>P_P</math> is at least 10 times the background power <math>P_B</math>, more preferably at least 100 times, and most preferably 1000 times to achieve the greatest effect of the invention.”).</p> <p>Wang at 4:29-31 (“...increases the sputtering rate but also at sufficiently high density ionizes a substantial fraction of the sputtered particles into positively charged metal ions.”).</p> <p>Wang at 7:31-39 (“...highly ionized sputtering...”)</p>
a) supplying feed gas proximate to an anode and a cathode assembly; and	<p>The combination of Wang and Kudryavtsev discloses supplying feed gas proximate to an anode and a cathode assembly.</p> <p>Wang at 3:66-4:1 (“A grounded shield 24 protects the chamber walls from sputter deposition and also acts as a grounded anode for the cathode of the negatively biased target 14.”)</p>

**EXHIBIT G.06**  
**U.S. Patent No. 7,808,184**

Claims 8 and 18	Wang in view of Kudryavtsev and Mozgrin
	<p>Wang at claim 27 “reactor [has an] anode with respect to a cathode of said target.” .</p> <p>Wang at 4:5-8 (“A sputter working gas such as argon is supplied from a gas source 32.... [and] flows into the processing region 22”).</p> <p>Wang at 4:20-21 (“a reactive gas, for example nitrogen is supplied to the processing space 22...”).</p> <p>Wang at Fig. 1:</p> <p align="center"><b>FIG. 1</b></p>
<p>b) generating a voltage pulse between the anode and the cathode assembly,</p>	<p>The combination of Wang and Kudryavtsev discloses generating a voltage pulse between the anode and the cathode assembly.</p> <p>Wang at Fig. 7:</p>

**EXHIBIT G.06**  
**U.S. Patent No. 7,808,184**

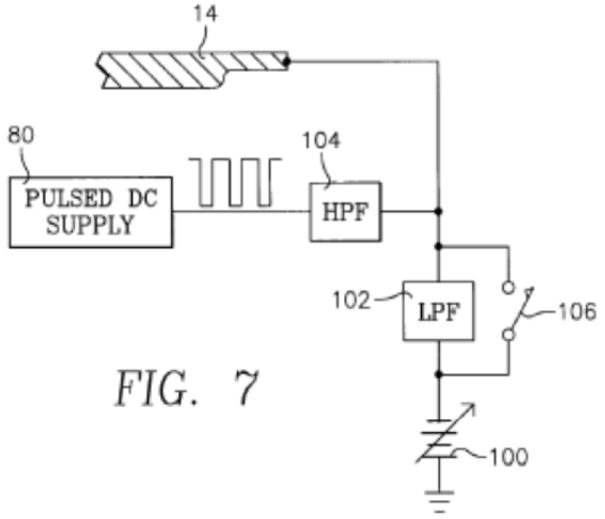
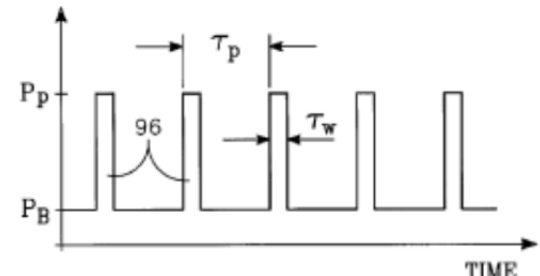
Claims 8 and 18	Wang in view of Kudryavtsev and Mozgrin
	 <p align="center">FIG. 7</p> <p>Wang at 7:61-62 (“The pulsed DC power supply 80 produces a train of negative voltage pulses.”).</p> <p>Wang at Fig. 1.</p> <p>Wang at Fig. 6:</p>  <p align="center">FIG. 6</p> <p>Wang at 3:66-4:1 (“A grounded shield 24 ... acts as a grounded anode for the cathode of the negatively biased target 14.”)</p>
<p>the voltage pulse having at least one of a controlled amplitude and a controlled rise time that increases an ionization rate so that a rapid</p>	<p>The combination of Wang and Kudryavtsev discloses the voltage pulse having at least one of a controlled amplitude and a controlled rise time that increases an ionization rate so that a rapid increase in electron density and a formation of a strongly-ionized plasma occurs.</p> <p>Wang at 7:28-30 (“... the application of the high peak power <math>P_p</math> instead quickly causes the already existing plasma to spread and increases the density of the plasma.”).</p> <p>Wang at 7:19-25 (“Preferably, the peak power <math>P_p</math> is at least 10 times the</p>

**EXHIBIT G.06**  
**U.S. Patent No. 7,808,184**

Claims 8 and 18	Wang in view of Kudryavtsev and Mozgrin
<p>increase in electron density and a formation of a strongly-ionized plasma occurs</p>	<p>background power <math>P_B</math> ... and most preferably 1000 times.... A background power <math>P_B</math> of one kW will typically be sufficient....”).</p> <p>Kudryavtsev at 32, right col, ¶¶ 5-6 (“The discharge occurred inside a cylindrical tube.... The gas was preionized by applying a dc current.... A voltage pulse ... was applied to the tube.”).</p> <p>Kudryavtsev at 31, right col, ¶ 6 (“an explosive increase in <math>n_e</math> [plasma density]. The subsequent increase in <math>n_e</math> then reaches its maximum value, equal to the rate of excitation [equation omitted], which is several orders of magnitude greater than the ionization rate during the initial stage.”)</p> <p>Kudryavtsev at Abstract (“electron density increases explosively in time due to accumulation of atoms in the lowest excited states”)</p> <p>Kudryavtsev at 34, right col, ¶ 4 (“the effects studied in this work are characteristic of ionization whenever a field is suddenly applied to a weakly ionized gas, they must be allowed for when studying emission mechanisms in pulsed gas lasers, gas breakdown, laser sparks, etc.”)</p> <p>Like Kudryavtsev’s voltage pulse, application of Wang’s voltage pulse (which produces the peak power <math>P_P</math>) to the weakly-ionized plasma rapidly increases the plasma density and the density of free electrons.</p> <p>If one of ordinary skill, did not experience Kudryavtsev’s “explosive increase” in plasma density in Wang, it would have been obvious to adjust the operating parameters, e.g., increase the pulse length and/or pressure, so as to trigger Kudryavtsev’s fast stage of ionization.</p> <p>One of ordinary skill would have been motivated to use Kudryavtsev’s fast stage of ionization in Wang so as to increase plasma density and thereby increase the sputtering rate. Also, Kudryavtsev’s fast stage would reduce the time required to reach a given plasma density in Wang, thus reducing the time required for a sputtering process. Further, use of Kudryavtsev’s fast stage in Wang would have been a combination of old elements that yielded predictable results. Finally, because Wang’s pulse, or the pulse used in the combination of Wang and Kudryavtsev, produced Kudryavtsev’s fast stage of ionization, the rise time and amplitude of the pulse result in increasing the ionization rate of excited atoms and creation of a multi-step ionization process.</p> <p>Also, Kudryavtsev states, “[s]ince the effects studied in this work are characteristic of ionization whenever a field is suddenly applied to a weakly ionized gas, they must be allowed for when studying emission mechanisms in pulsed gas lasers, gas breakdown, laser sparks, etc.” Kudryavtsev at 34, right</p>

**EXHIBIT G.06**  
**U.S. Patent No. 7,808,184**

Claims 8 and 18	Wang in view of Kudryavtsev and Mozgrin
	<p>col, ¶ 4 (emphasis added). Because Wang applies voltage pulses that “suddenly generate an electric field,” one of ordinary skill reading Wang would have been motivated to consider Kudryavtsev and to use Kudryavtsev’s fast stage in Wang.</p> <p>Finally, Wang’s voltage pulse has both a controlled amplitude and rise time as required by claim 1. Wang specifies that the background power <math>P_B</math> can be 1 kV and that the peak power <math>P_P</math> can be 1,000 times greater than the background power, i.e., 1 MW. Wang at 7:19-25 (“Preferably, the peak power <math>P_P</math> is at least 10 times the background power <math>P_B</math> ... and most preferably 1000 times.... A background power <math>P_B</math> of one kW will typically be sufficient....”). One of ordinary skill would have understood that Wang’s voltage amplitude was controlled to produce Wang’s specified peak power level <math>P_P</math>.</p> <p>The rise time of Wang’s voltage pulse is also controlled. Wang at 5:23-26 (“The illustrated pulse form is idealized. Its exact shape depends on the design of the pulsed DC power supply 80, and significant rise times and fall times are expected.”)</p>
without forming an arc between the anode and the cathode assembly.	<p>The combination of Wang and Kudryavtsev discloses without forming an arc between the anode and the cathode assembly.</p> <p>Wang at Fig. 6</p> <p>Wang at 7:3-6 (“Plasma ignition, particularly in plasma sputter reactors, has a tendency to generate particles during the initial arcing, which may dislodge large particles from the target or chamber.”)</p> <p>Wang at 7:47-49 (“The initial plasma ignition needs be performed only once and at much lower power levels so that particulates produced by arcing are much reduced.”).</p> <p>Wang at 7:13-28 (“Accordingly, it is advantageous to use a target power waveform illustrated in FIG. 6.... As a result, once the plasma has been ignited at the beginning of sputtering prior to the illustrated waveform....”).</p>
8. The method of claim 1 further comprising discharging energy from an energy storage device into the plasma to enhance the	<p>The combination of Wang, Kudryavtsev and Mozgrin discloses discharging energy from an energy storage device into the plasma to enhance the rapid increase in electron density and the formation of the strongly-ionized plasma.</p> <p><i>See</i> evidence cited for claim 1.</p> <p>Wang at 7:61-62 (“pulsed DC power supply 80 produces a train of negative voltage pulses.”).</p> <p>Mozgrin at Fig. 2.</p>



# Explore Litigation Insights

Docket Alarm provides insights to develop a more informed litigation strategy and the peace of mind of knowing you're on top of things.

## Real-Time Litigation Alerts



Keep your litigation team up-to-date with **real-time alerts** and advanced team management tools built for the enterprise, all while greatly reducing PACER spend.

Our comprehensive service means we can handle Federal, State, and Administrative courts across the country.

## Advanced Docket Research



With over 230 million records, Docket Alarm's cloud-native docket research platform finds what other services can't. Coverage includes Federal, State, plus PTAB, TTAB, ITC and NLRB decisions, all in one place.

Identify arguments that have been successful in the past with full text, pinpoint searching. Link to case law cited within any court document via Fastcase.

## Analytics At Your Fingertips



Learn what happened the last time a particular judge, opposing counsel or company faced cases similar to yours.

Advanced out-of-the-box PTAB and TTAB analytics are always at your fingertips.

## API

Docket Alarm offers a powerful API (application programming interface) to developers that want to integrate case filings into their apps.

## LAW FIRMS

Build custom dashboards for your attorneys and clients with live data direct from the court.

Automate many repetitive legal tasks like conflict checks, document management, and marketing.

## FINANCIAL INSTITUTIONS

Litigation and bankruptcy checks for companies and debtors.

## E-DISCOVERY AND LEGAL VENDORS

Sync your system to PACER to automate legal marketing.