

FILE HISTORY

US 5,915,210

PATENT: 5,915,210

INVENTORS: Cameron, Dennis Wayne
Roehr, Jr., Walter Charles
Bhagat, Jai P.
Garahi, Masood
Hays, William D.
Ackerman, David W.

TITLE: Method and system for providing
multicarrier simulcast transmission

APPLICATION NO: US1997899476A

FILED: 24 JUL 1997

ISSUED: 22 JUN 1999

COMPILED: 19 AUG 2013

60245 U.S. PTO
08/899476
07/24/97
Class Subclass
ISSUE CLASSIFICATION
SCANNED 6

5915210

UTILITY SERIAL NUMBER	PATENT DATE JUN 22 1999	PATENT NUMBER	5915210		
SERIAL NUMBER 08/899,476	FILING DATE 07/24/97	CLASS 455	SUBCLASS C03	GROUP ART UNIT 2611	EXAMINER

APPLICANTS DENNIS WAYNE CAMERON, JACKSON, MS; WALTER CHARLES ROEHR JR., RESTON, VA; JAI P. BHAGAT, JACKSON, MS; MASOOD GARAH, MADISON, MS; WILLIAM D. HAYS, JACKSON, MS; DAVID W. ACKERMAN, WASHINGTON, DC.

BEST COPY

CONTINUING DATA***
VERIFIED THIS APPLN IS A CON OF 08/760,457 12/06/96 ABN
which IS AND A CON OF 07/973,918 11/12/92 PAT 5,590,403
YES

FOREIGN/PCT APPLICATIONS***
VERIFIED
NONE

**CERTIFICATE
NOV 23 1999
OF CORRECTION**

FOREIGN FILING LICENSE GRANTED 09/10/97

Foreign priority claimed 35 USC 119 conditions met	<input type="checkbox"/> yes <input checked="" type="checkbox"/> no	AS FILED	STATE OR COUNTRY MS	SHEETS DRWGS. 29	TOTAL CLAIMS 18	INDEP. CLAIMS 2	FILING FEE RECEIVED \$770.00	ATTORNEY'S DOCKET NO. 3680,0083-05
---	---	----------	------------------------	---------------------	--------------------	--------------------	---------------------------------	---------------------------------------

Verified and Acknowledged
Examiner's initials
FINNEGAN HENDERSON FARABOW GARRETT AND DUNNER
1300 I STREET NW
WASHINGTON DC 20005-3315

TITLE METHOD AND SYSTEM FOR PROVIDING MULTICARRIER SIMULCAST TRANSMISSION
U.S. DEPT. OF COMM/PAT. & TM-PTO-436L (Rev.12-94)

PARTS OF APPLICATION FILED SEPARATELY		Riddick Applications Examiner	
NOTICE OF ALLOWANCE MAILED 4-16-98	Assistant Examiner	CLAIMS ALLOWED Total Claims 19 Print Claim 1	
ISSUE FEE Amount Due 1320.00 Date Paid	Thalye 4-10-98 THANH CONG LE PRIMARY EXAMINER GROUP 2700 Primary Examiner	DRAWING Sheets Drwg. 29 Figs. Drwg. 40 Print Fig. 6	
Label Area		ISSUE BATCH NUMBER D05	
PREPARED FOR ISSUE			
WARNING: The information disclosed herein may be restricted. Unauthorized disclosure may be prohibited by the United States Code Title 35, Sections 122, 181 and 368. Possession outside the U.S. Patent & Trademark Office is restricted to authorized employees and contractors only.			

Form PTO-436A (Rev. 8/92)
SCANNED 6 omw
QC RG 55

(FACE)

455	Class
59	Subclass



TEAM 6

UTILITY SERIAL NUMBER	08/760457	PATENT DATE		PATENT NUMBER	
-----------------------	-----------	-------------	--	---------------	--

SERIAL NUMBER	08/760,457	FILING DATE	12/06/96	CLASS	455	SUBCLASS	59	GROUP ART UNIT	2611	EXAMINER	Le, T.
		RULE 60									

APPLICANTS DENNIS W. CAMERON, JACKSON, MS; WALTER C. ROEHR JR., RESTON, VA; JAI P. BHAGAT, JACKSON, MS; MASOOD GARAH, MADISON, MS; WILLIAM D. HAYS, JACKSON, MS; DAVID W. ACKERMAN, WASHINGTON, DC.

CONTINUING DATA***
 VERIFIED THIS APPLN IS A CON. OF 07/973,918 11/12/92 PAT 5,590,403

YES TV

FOREIGN/PCT APPLICATIONS***
 VERIFIED

NONE TV

FOREIGN FILING LICENSE GRANTED 02/12/97

Foreign priority claimed	<input type="checkbox"/> yes <input checked="" type="checkbox"/> no	AS FILED	STATE OR COUNTRY	SHEETS DRWGS.	TOTAL CLAIMS	INDEP. CLAIMS	FILING FEE RECEIVED	ATTORNEY'S DOCKET NO.
35 USC 119 conditions met	<input type="checkbox"/> yes <input checked="" type="checkbox"/> no		MS	29	1	1	\$770.00	03680.0083-0

Verified and Acknowledged
 Examiner's Initials
 FINNEGAN HENDERSON FARABOW
 GARRETT AND DUNNER
 1300 I STREET NW
 WASHINGTON DC 20005-3315

METHOD AND SYSTEM FOR PROVIDING MULTICARRIER SIMULCAST TRANSMISSION

U.S. DEPT. OF COMM./PAT. & TM--PTO-438L (Rev.12-94)

PARTS OF APPLICATION FILED SEPARATELY		THANK LE		CLAIMS ALLOWED	
NOTICE OF ALLOWANCE MAILED		Assistant Examiner		Total Claims	Print Claim
4-25-97				18	1
ISSUE FEE		Reinhard J. Eisenzopf		DRAWING	
Amount Due	Date Paid	3-15-97		Sheets Drwg.	Figs. Drwg.
5,290.00		Supervisory Patent Examiner		29	40
		Group 2600		Print Fig.	6
		Primary Examiner		ISSUE BATCH NUMBER	
Label Area		PREPARED FOR ISSUE		1125	
WARNING: The information disclosed herein may be restricted. Unauthorized disclosure may be prohibited by the United States Code Title 35, Sections 122, 181 and 388. Possession outside the U.S. Patent & Trademark Office is restricted to authorized employees and contractors only.					

Form PTO-436A (Rev. 8/92)

(FACE)

08/760,457

**METHOD AND SYSTEM FOR PROVIDING MULTICARRIER
SIMULCAST TRANSMISSION**

Transaction History

Date	Transaction Description
12-06-1996	Incoming Letter Pertaining to the Drawings
12-06-1996	Preliminary Amendment
12-06-1996	Preliminary Amendment
01-03-1997	Initial Exam Team nn
02-21-1997	Application Captured on Microfilm
03-07-1997	Case Docketed to Examiner in GAU
04-25-1997	Mail Notice of Allowance
04-25-1997	Notice of Allowance Data Verification Completed
04-25-1997	Mail Examiner's Amendment
04-25-1997	Examiner's Amendment Communication
03-25-1998	Mail Abandonment for Failure to Correct Drawings/Oath
03-25-1998	Abandonment for Failure to Correct Drawings/Oath/NonPub Request
04-09-1998	Abandonment for Purposes of Filing an FWC - File Combined with Child Application

5,915,210

**METHOD AND SYSTEM FOR PROVIDING MULTICARRIER
SIMULCAST TRANSMISSION**

Transaction History

Date	Transaction Description
07-24-1997	Preliminary Amendment
08-21-1997	Initial Exam Team nn
08-26-1997	IFW Scan & PACR Auto Security Review
09-12-1997	Amendment after Notice of Allowance (Rule 312)
09-12-1997	Information Disclosure Statement (IDS) Filed
09-12-1997	Information Disclosure Statement (IDS) Filed
09-15-1997	Application Dispatched from OIPE
12-19-1997	Information Disclosure Statement (IDS) Filed
12-19-1997	Information Disclosure Statement (IDS) Filed
04-09-1998	Case Docketed to Examiner in GAU
04-16-1998	Mail Notice of Allowance
04-16-1998	Notice of Allowance Data Verification Completed
04-16-1998	Mail Examiner's Amendment
04-16-1998	Examiner's Amendment Communication
06-16-1998	Issue Fee Payment Verified
06-16-1998	Mailroom Date of Drawing(s)
06-19-1998	Application Ordered to Match Drawing(s)
06-19-1998	Drawing(s) Received at Publications
06-24-1998	Application Received to Match Drawing(s)
07-28-1998	Drawing(s) Processing Completed
07-28-1998	Drawing(s) Matched to Application
09-15-1998	Date Forwarded to Examiner
09-23-1998	Mail Response to 312 Amendment (PTO-271)
09-23-1998	Response to Amendment under Rule 312
01-06-1999	Mailroom Date of Drawing(s)
01-08-1999	Drawing(s) Received at Publications
06-11-1999	Issue Notification Mailed
06-22-1999	Recordation of Patent Grant Mailed
10-27-1999	Post Issue Communication - Certificate of Correction

08/760457

PATENT APPLICATION



08760457

APPROVED FOR LICENSE

INITIALS IAN 293743

Date Entered or Counted

CONTENTS

Date Received or Mailed

1.	Application	papers.	
2.	PreAmdt A		12/6/96
3.	PreAmdt B		12/6/96
4.	Ltr. to Draftsman		12/6/96
5.	Notice of Abandonment		4-25-97
6.	Notice of Abandonment		3/25/98
7.			
8.			
9.			
10.			
11.			
12.			
13.			
14.			
15.			
16.			
17.			
18.			
19.			
20.			
21.			
22.			
23.			
24.			
25.			
26.			
27.			
28.			
29.			
30.			
31.			
32.			

3/13/97

(FRONT)



PATENT APPLICATION



APPROVED FOR LICENSE

INITIALS _____

Date Entered or Counted

CONTENTS

Date Received or Mailed

Date Entered or Counted	Application _____ papers.	Date Received or Mailed
7	Pre Amdt C	7/24/97
8	Notice of Allowability	4/16/98
6/24/99	Formal Drawings (30 sheets)	6/16/98
10	Notice of Drawing Requirement	7/23/98
11	I.D.S. w/ref	9/12/97
12	I.D.S. w/ref	12/19/97
13	Amdt D (Rule 312) (PPT)	9/12/97
9/21/98	14 Notice of Entry	9-23-98 sc
15	PTO Grant JUN 2 2 1999	
16	Req for Exp C	8-9-99
17		
18		
19		
20		
21		
22		
23		
24		
25		
26		
27		
28		
29		
30		

Staple Issue Slip Here

POSITION	ID NO.	DATE
CLASSIFIER	12	1/29/77
EXAMINER	42	2/10/77
TYPIST	PK	2/12
VERIFIER 451	2/13 441	2/15
CORPS CORR.		
SPEC. HAND		
FILE MAINT.		
DRAFTING		

INDEX OF CLAIMS

Claim	Date	
	Final	Original
1	11	11
2	8	11
3	9	
4	10	
5	11	
6	12	
7	13	
8	14	
9	15	
10	16	
11	17	
12	18	
13	19	
14	20	
15	21	
16	22	
17	23	
18	24	11
19		
20		
21		
22		
23		
24		
25		
26		
27		
28		
29		
30		
31		
32		
33		
34		
35		
36		
37		
38		
39		
40		
41		
42		
43		
44		
45		
46		
47		
48		
49		
50		

Claim	Date	
	Final	Original
51		
52		
53		
54		
55		
56		
57		
58		
59		
60		
61		
62		
63		
64		
65		
66		
67		
68		
69		
70		
71		
72		
73		
74		
75		
76		
77		
78		
79		
80		
81		
82		
83		
84		
85		
86		
87		
88		
89		
90		
91		
92		
93		
94		
95		
96		
97		
98		
99		
100		

SYMBOLS
 ✓ Rejected
 = Allowed
 - (Through numeral) Canceled
 R Restricted
 N Non-elected
 I Interference
 A Appeal
 O Objected

(LEFT INSIDE)

Staple Issue Slip Here

POSITION	ID NO.	DATE
CLASSIFIER		
EXAMINER	<i>CAF</i>	<i>4/12/07</i>
TYPIST		
VERIFIER		
CORPS CORR.		
SPEC. HAND		
FILE MAINT.		
DRAFTING		

INDEX OF CLAIMS

Claim		Date
Final	Original	
	103614	
1	(2)	11
2	8	11
3	9	
4	10	
5	11	
6	12	
7	13	
8	14	
9	15	
10	(16)	
11	17	
12	18	
13	19	
14	20	
15	21	
16	22	
17	23	
18	24	11
19	25	11
20	26	
21	27	
22	28	
23	29	
24	30	
25	31	
26	32	
27	33	
28	34	
29	35	
30	36	
31	37	
32	38	
33	39	
34	40	
35	41	
36	42	
37	43	
38	44	
39	45	
40	46	
41	47	
42	48	
43	49	
44	50	

Claim		Date
Final	Original	
	51	
	52	
	53	
	54	
	55	
	56	
	57	
	58	
	59	
	60	
	61	
	62	
	63	
	64	
	65	
	66	
	67	
	68	
	69	
	70	
	71	
	72	
	73	
	74	
	75	
	76	
	77	
	78	
	79	
	80	
	81	
	82	
	83	
	84	
	85	
	86	
	87	
	88	
	89	
	90	
	91	
	92	
	93	
	94	
	95	
	96	
	97	
	98	
	99	
	100	

- SYMBOLS
- ✓ Rejected
 - ✗ Allowed
 - (Through numbers) Canceled
 - + Restricted
 - N Non-elected
 - I Interference
 - A Appeal
 - O Objected

(LEFT INSIDE)

SEARCHED			
Class	Sub.	Date	Exmr.
453	12.1 33.1 34.1 53.1 54.1 54.2 57.2 58.1 56.1 62 63 67.1 101 102 103	3/10/97	TV
375	260 267 299	3/10/97	TV
370	343 344		

SEARCH NOTES		
	Date	Exmr.
J. Dwyer (QAs) Double patenting rejection (non-substantive)	3/7/97	TV
P. Vo (class 375)	3/10/97	TV
H. Vu (class 370)	3/10/97	TV

INTERFERENCE SEARCHED			
Class	Sub.	Date	Exmr.
453	59 102 103	3/10/97	TV

(RIGHT OUTSIDE)



SEARCHED			
Class	Sub.	Date	Exmr.
455	502	4/8/98	R
	503		
	507		
	509		
	515		
	516		
	517		
	524		
	59		
	60		
	62		
	63		
	67.1		
	67.3		
67.6			
101			
102			
103			
375	260	4/8/98	R
	267		
	299		
370	343	4/8/98	R
	344		

*I should have
to see the
the*

SEARCH NOTES		
	Date	Exmr.
none	4/8/98	R

INTERFERENCE SEARCHED			
Class	Sub.	Date	Exmr.
455	59	4/10/98	R
	102		
	103		

(RIGHT OUTSIDE)



United States Patent [19]
Cameron et al.

[11] **Patent Number:** **5,915,210**
 [45] **Date of Patent:** **Jun. 22, 1999**

<p>[54] METHOD AND SYSTEM FOR PROVIDING MULTICARRIER SIMULCAST TRANSMISSION</p> <p>[75] Inventors: Dennis Wayne Cameron, Jackson, Miss.; Walter Charles Roehr, Jr., Reston, Va.; Jal P. Bhagat, Jackson, Miss.; Masood Garahi, Madison, Miss.; William D. Hays, Jackson, Miss.; David W. Ackerman, Washington, D.C.</p>	<p>4,490,830 12/1984 Kai et al. 455/59</p> <p>4,506,384 3/1985 Lucas</p> <p>4,570,265 2/1986 Thro 455/59</p> <p>4,701,758 10/1987 Dunkerton et al.</p> <p>4,850,032 7/1989 Freeburg</p> <p>4,968,966 11/1990 Jasinski 455/51.2</p> <p>5,128,934 7/1992 Jasinski</p> <p>5,163,181 11/1992 Koontz</p> <p>5,243,629 9/1993 Wei 375/299</p> <p>5,343,499 8/1994 Jasper et al.</p> <p>5,392,452 2/1995 Davis</p> <p>5,504,783 4/1996 Tomisato et al. 455/101</p>
---	--

[73] **Assignee:** Destneer Corporation, Jackson, Miss.

[21] **Appl. No.:** 08/899,476

[22] **Filed:** Jul. 24, 1997

Related U.S. Application Data

[63] Continuation of application No. 08/760,457, Dec. 6, 1996, abandoned, which is a continuation of application No. 07/973,918, Nov. 12, 1992, Pat. No. 5,590,405.

[51] **Int. Cl.⁶** H04B 1/50

[52] **U.S. Cl.** 455/59; 455/102; 455/103

[58] **Field of Search** 455/502, 503, 455/507, 509, 515, 516, 517, 524, 59, 60, 62, 63, 67.1, 67.3, 67.6, 101, 102, 103; 375/260, 267, 299, 370/343, 344

References Cited

[56] **U.S. PATENT DOCUMENTS**

3,488,445	1/1970	Chang	
3,914,554	10/1975	Seidel	
4,223,405	9/1980	Hattori et al.	455/59
4,244,047	1/1981	Perkins	
4,392,242	7/1983	Kai	455/34.1

FOREIGN PATENT DOCUMENTS

WO 90/04314	4/1990	European Pat. Off.	
WO91/18458	11/1991	WIPO	455/101
WO92/11707	7/1992	WIPO	455/33.1

Primary Examiner—Thanh Cong Le
Attorney, Agent, or Firm—Finnegan, Henderson, Farabow, Garrett & Dunner

[57] **ABSTRACT**

A two-way communication system for communication between a system network and a mobile unit. The system network includes a plurality of base transmitters and base receivers include in the network. The base transmitters are divided into zonal assignments and broadcast in simulcast using multi-carrier modulation techniques. The system network controls the base transmitters to broadcast in simulcast during both systemwide and zone boundaries to maximize information throughout. The preferred mobile unit includes a noise detector circuit to prevent unwanted transmissions. The system network further provides an adaptive registration feature for mobile units which controls the registration operation by the mobile units to maximize information throughout.

19 Claims, 30 Drawing Sheets

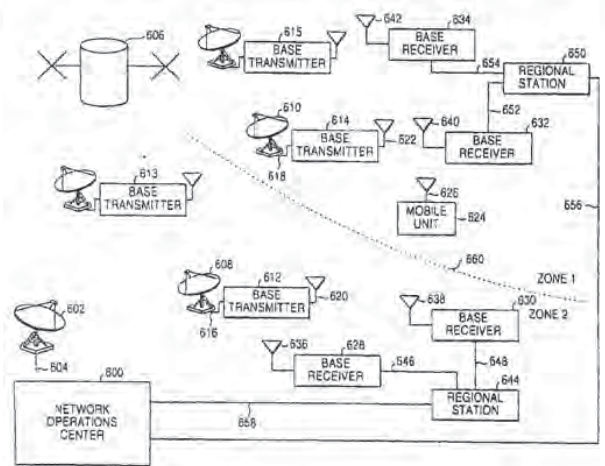
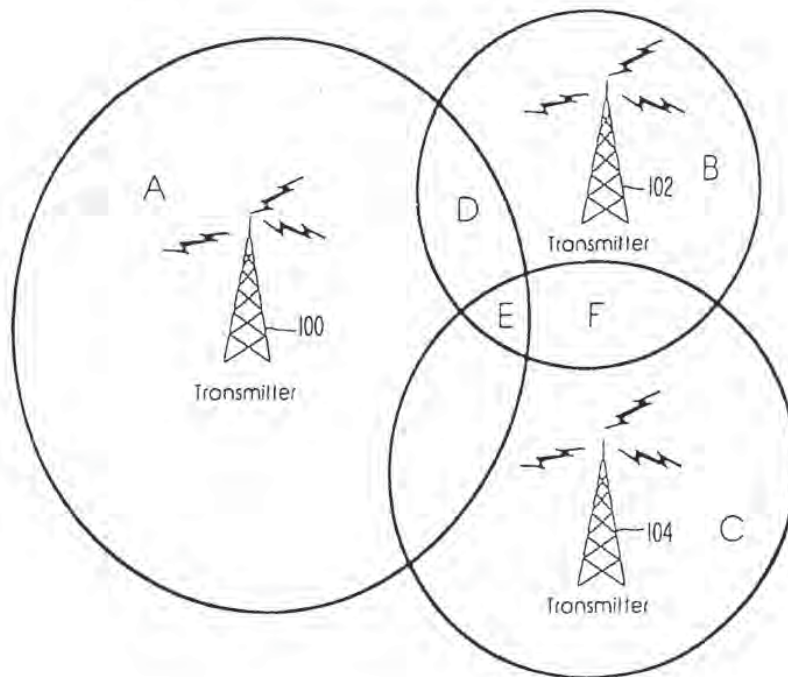
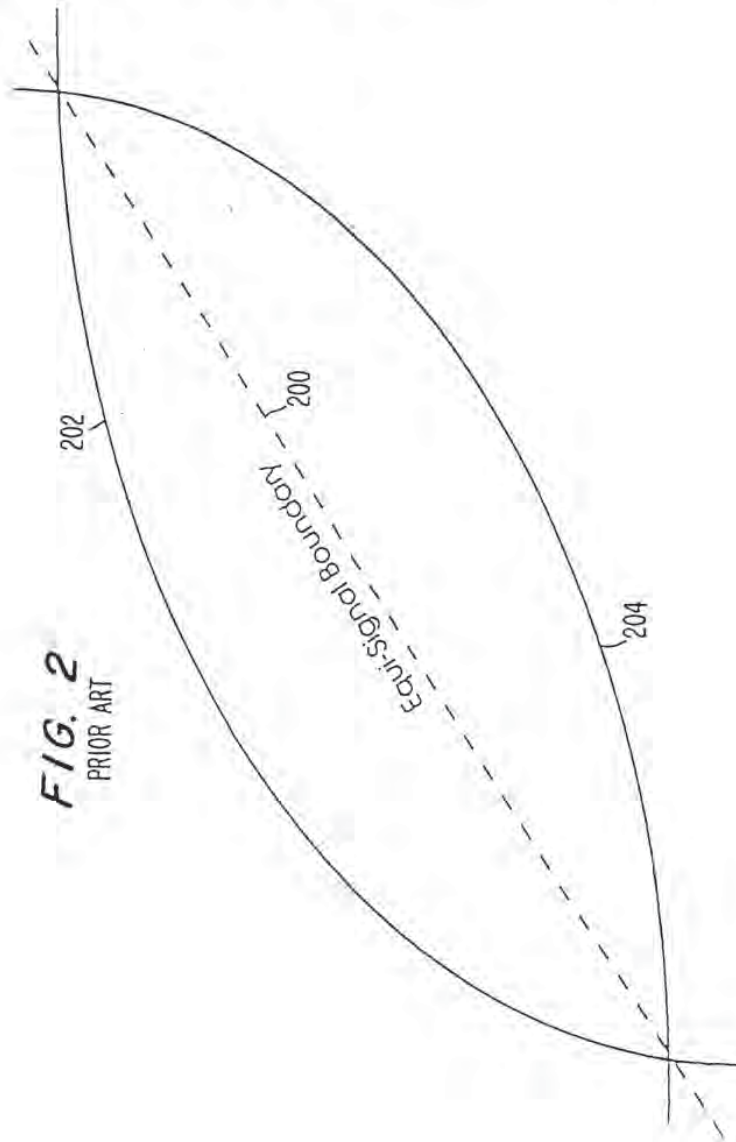

FIG. 1
PRIOR ART





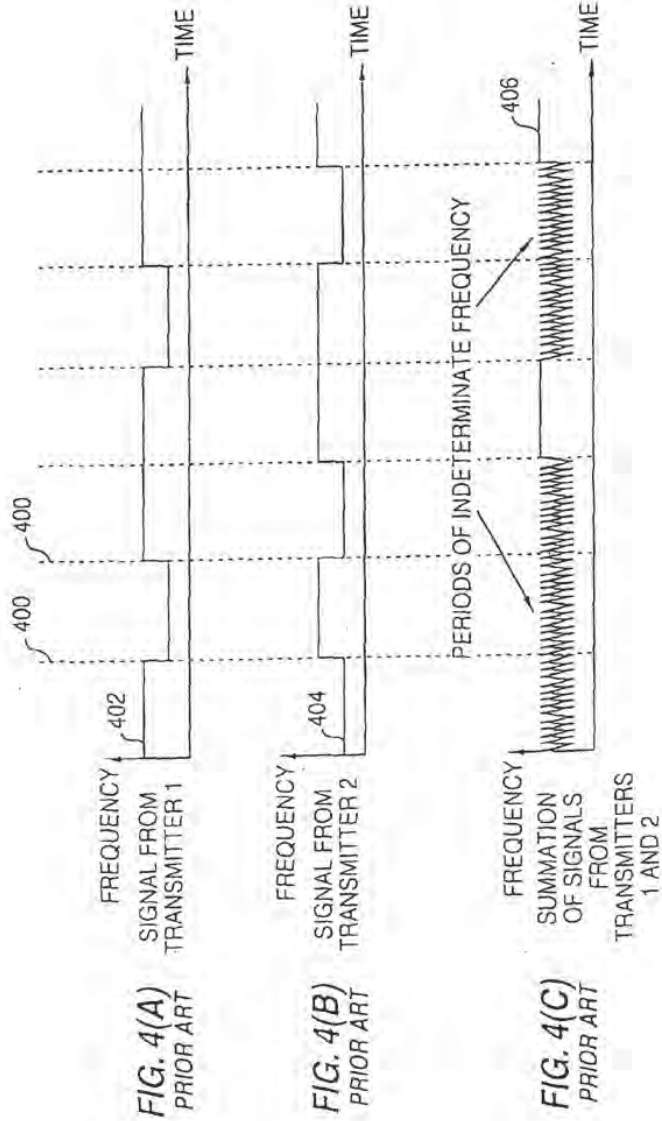
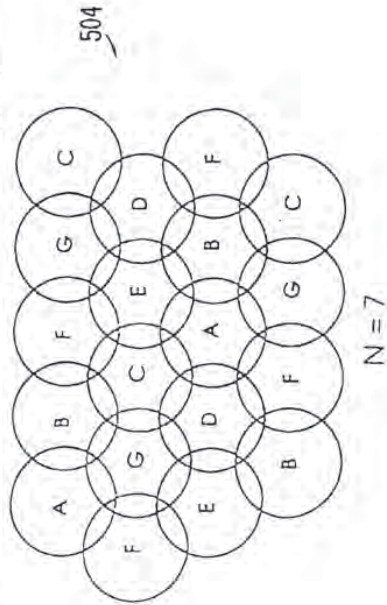
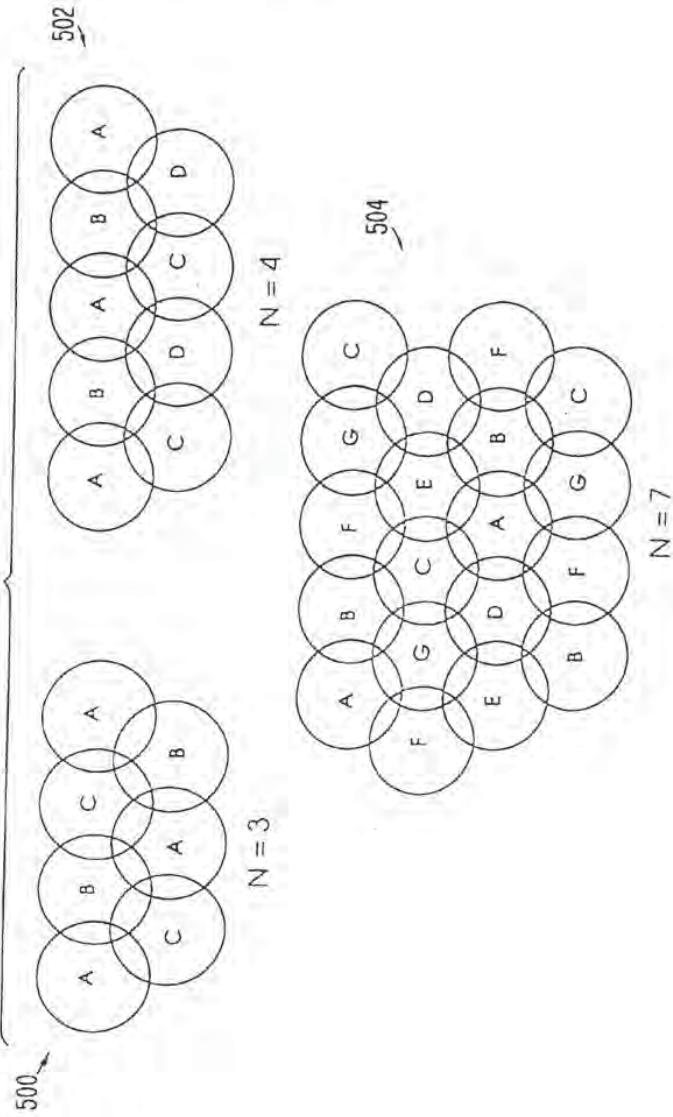

FIG. 5 PRIOR ART



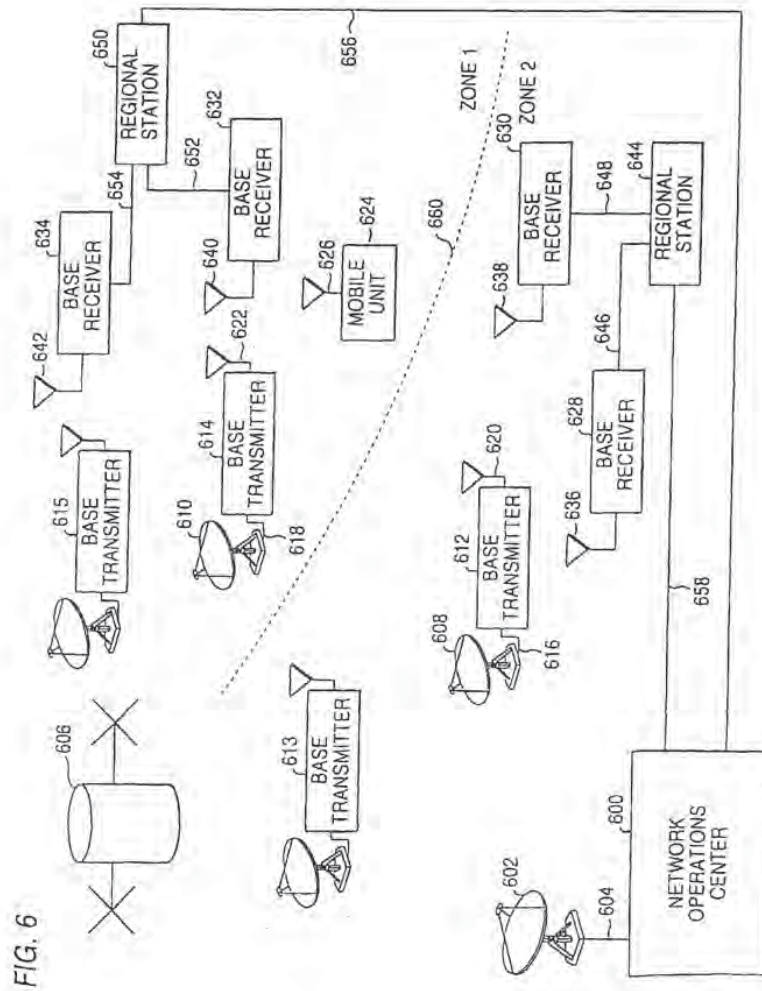

FIG. 7

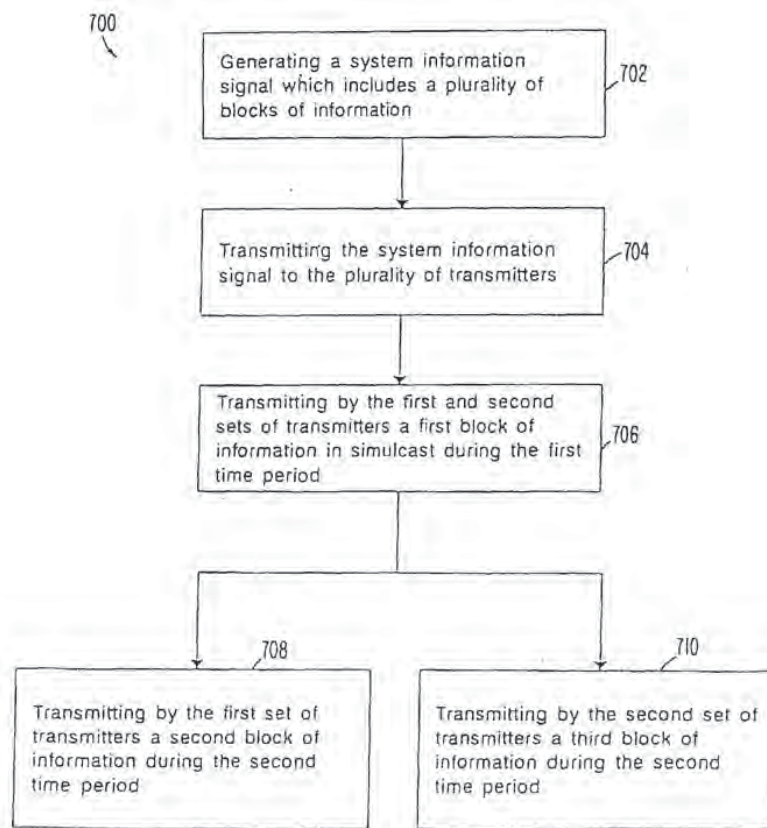
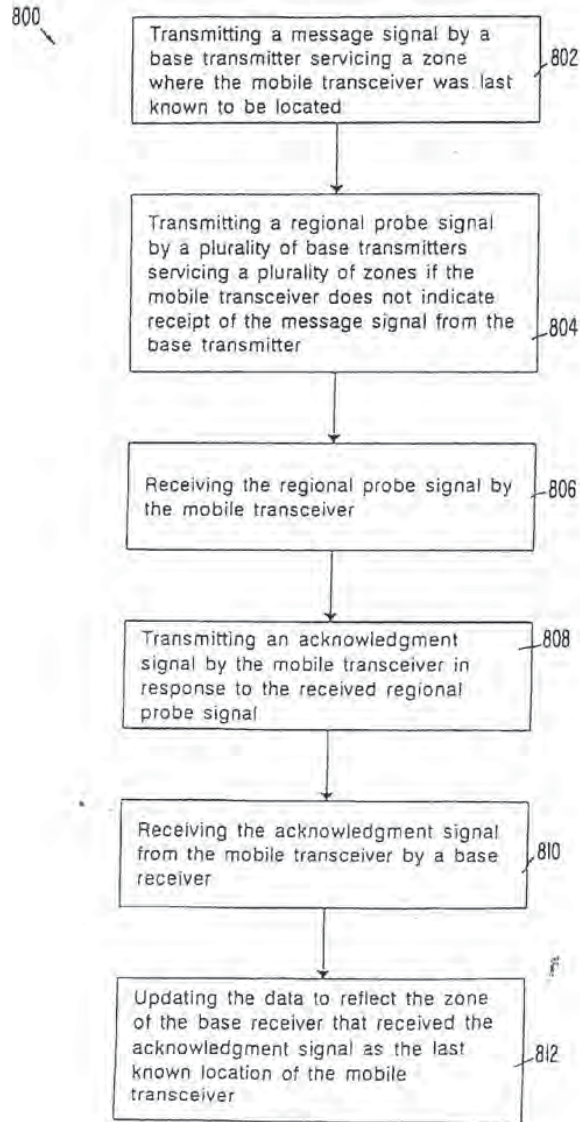

FIG. 8



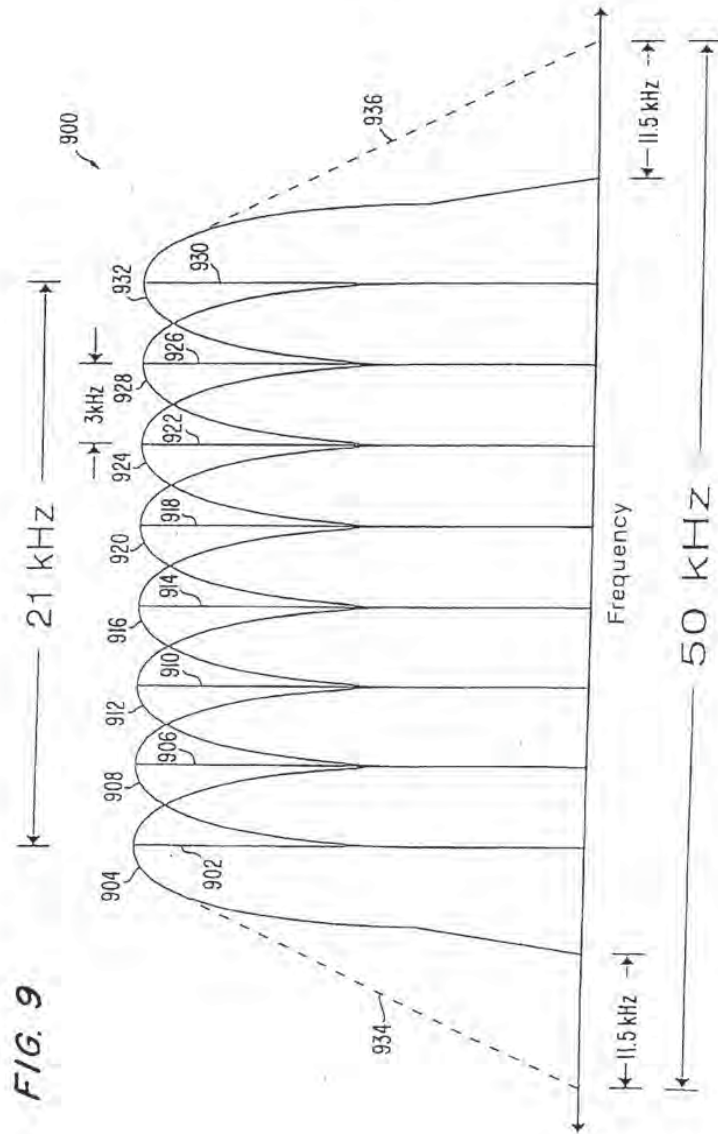

FIG. 9

FIG. 10

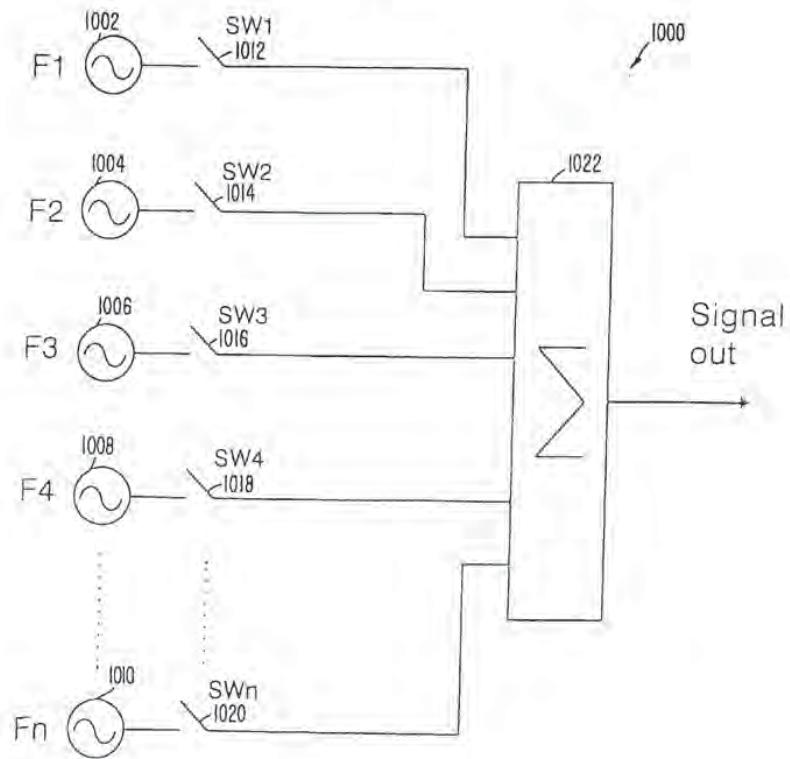

FIG. 11

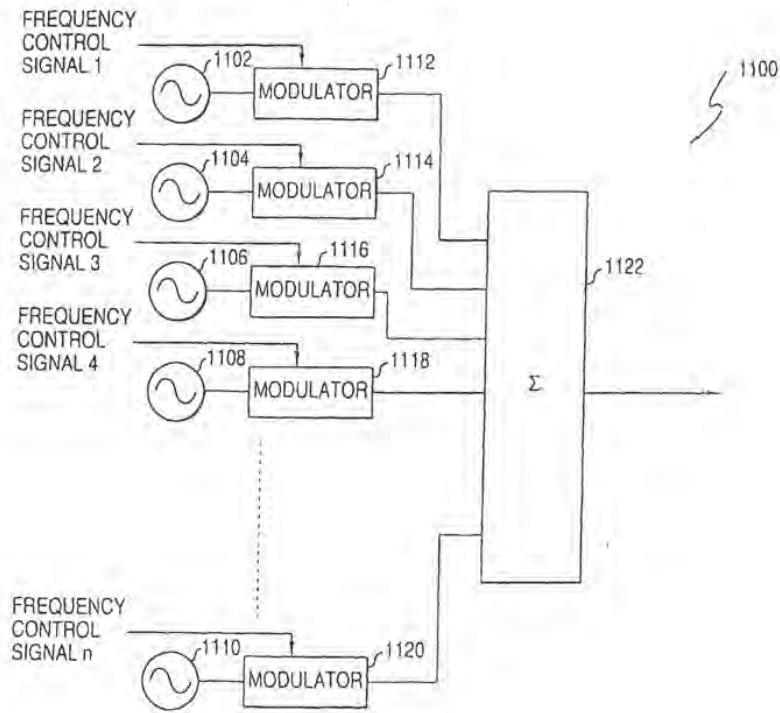
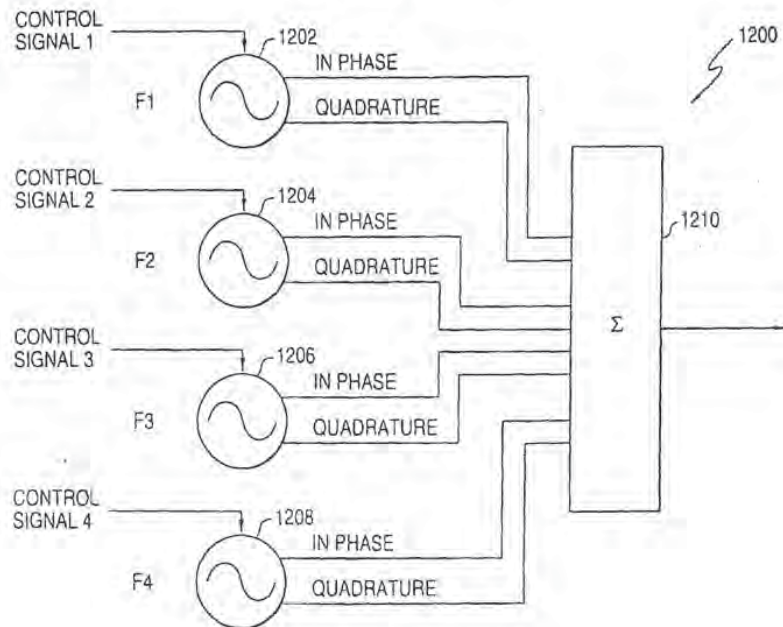

FIG. 12



FOUR CARRIER QUADRATURE MODULATOR

Base Transmitter

FIG. 13

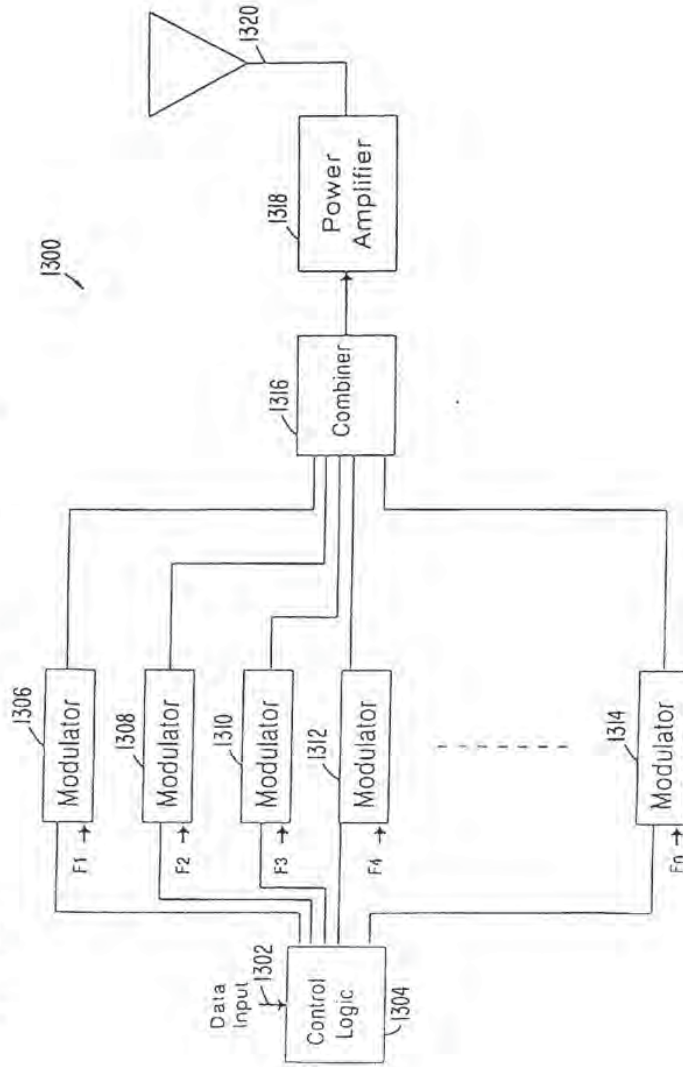

FIG. 14

Base Transmitter

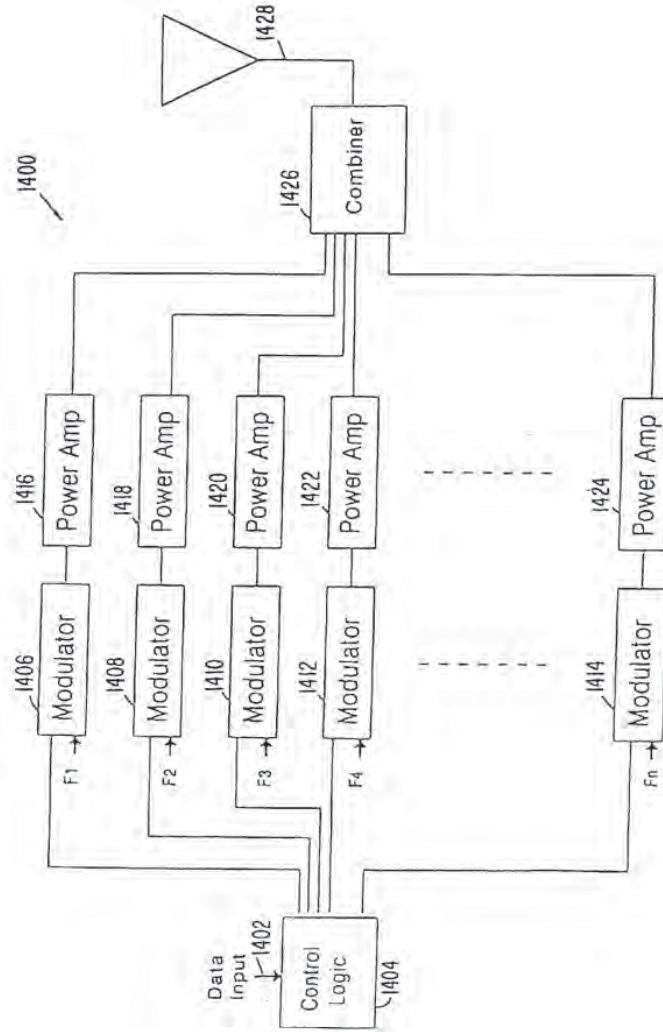

FIG. 15

Mobile Transceiver

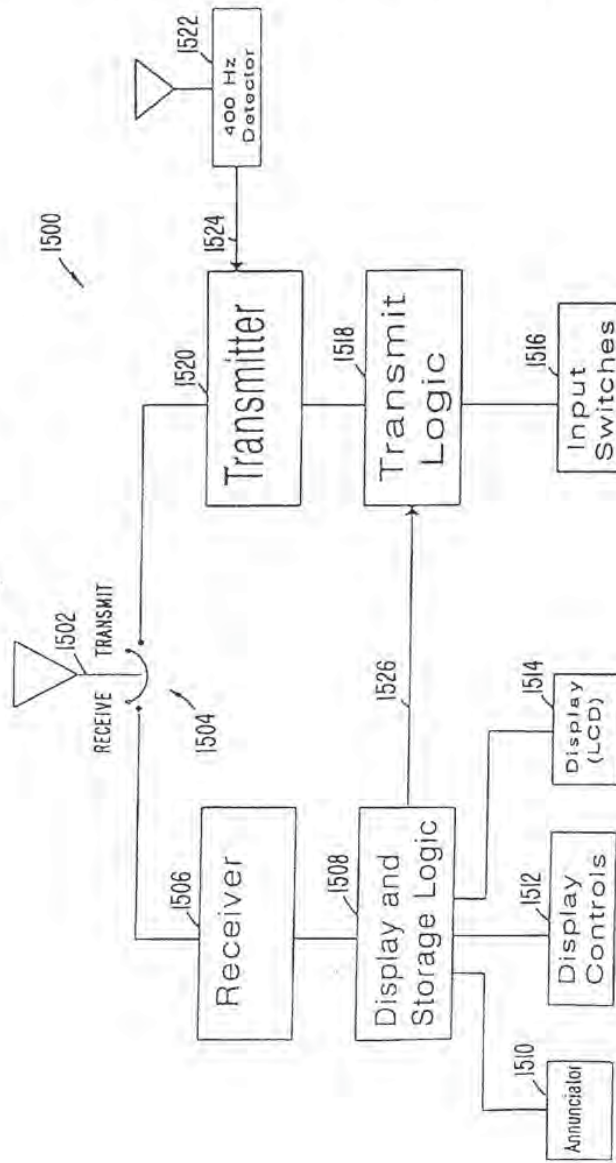

FIG. 16

1600

1602

1604

1606

1620

Will You Be Home For Dinner?

Yes No ? Unused Unused Unused

1608 1610 1612 1614 1616 1618

Mobile Transceiver

FIG. 17

Mobile Receiver

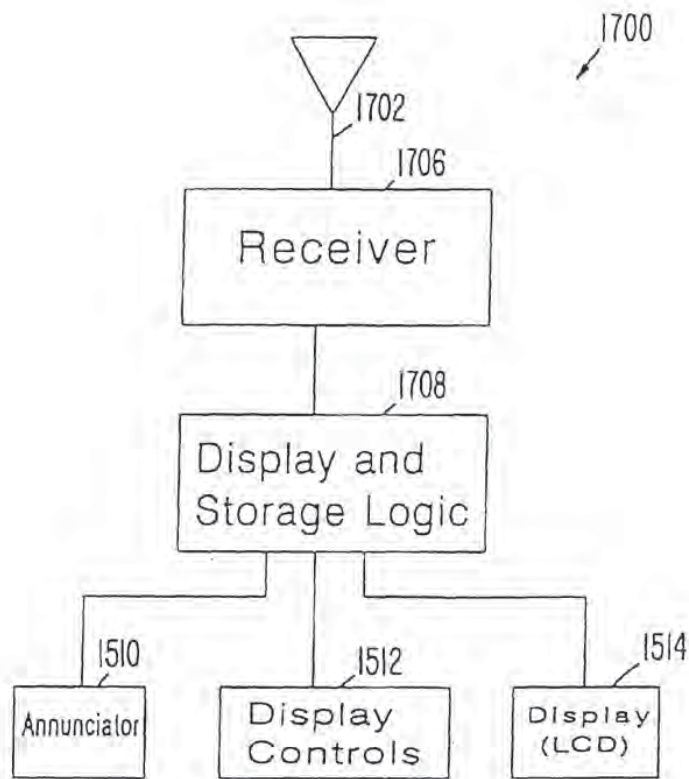

FIG. 18(A)

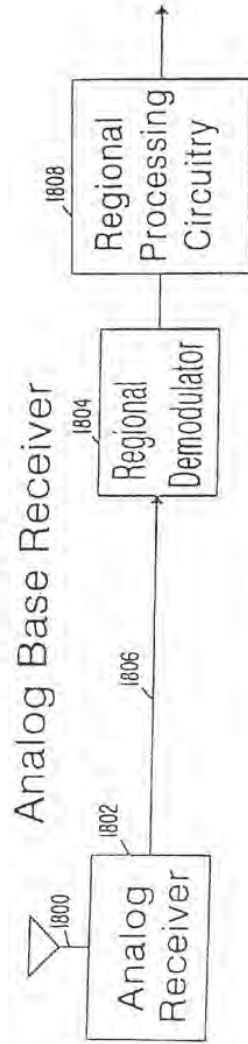

FIG. 18(B)

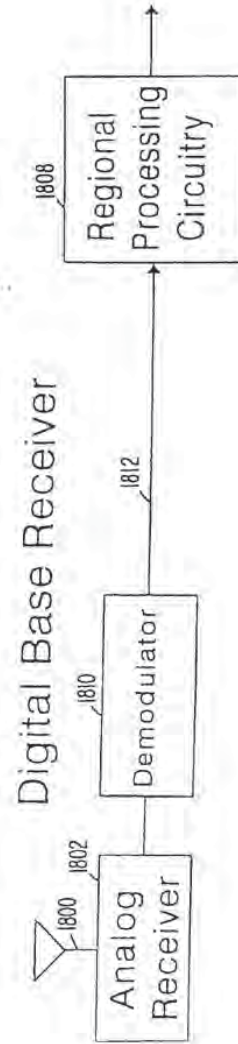
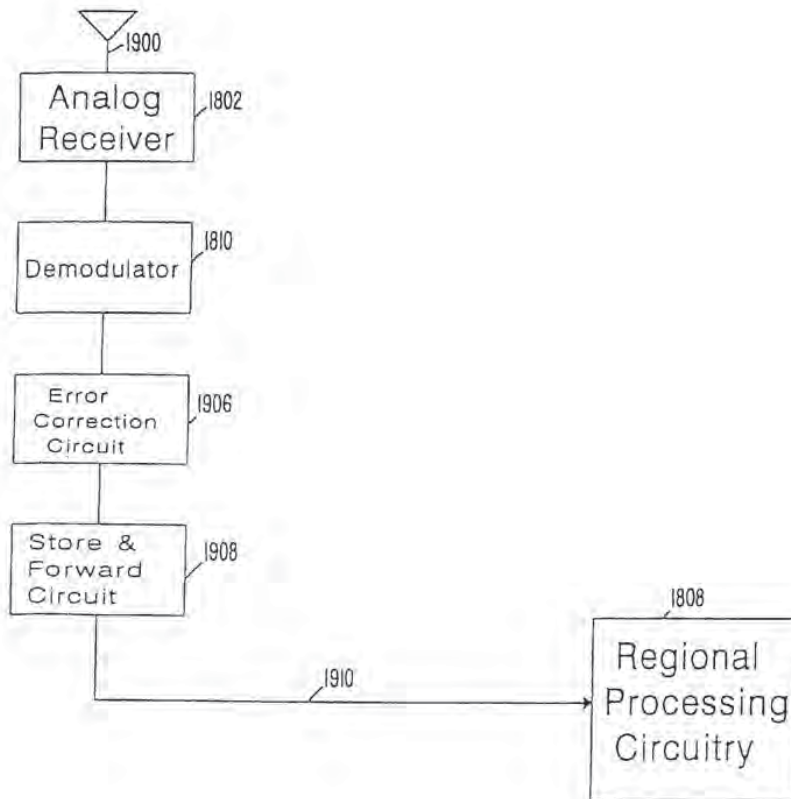

FIG. 19



Network Operations Center

FIG. 20

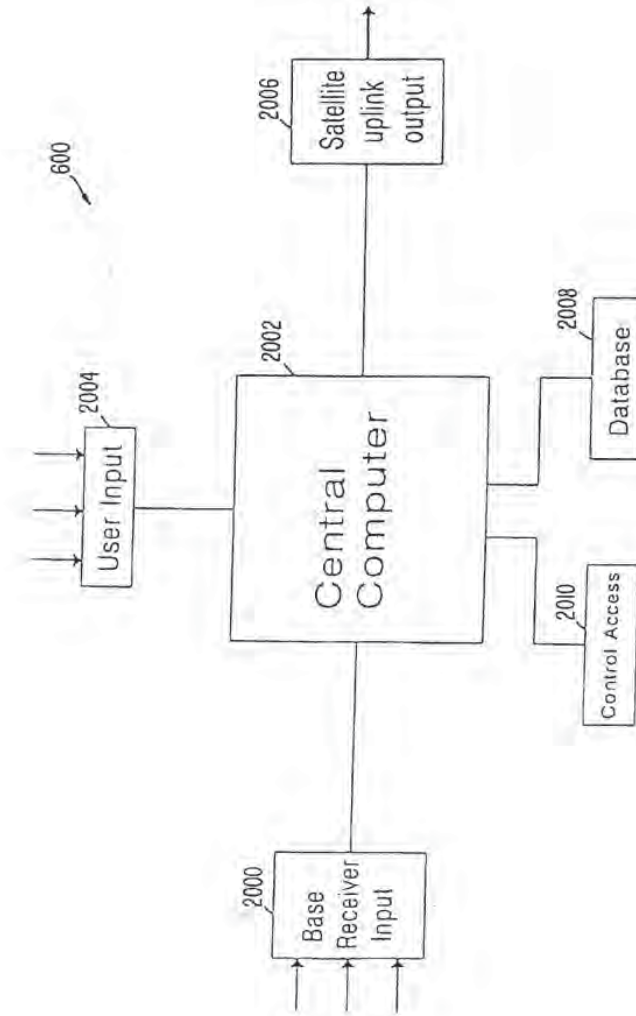

FIG. 21

2102		2104		2106	
User 1	ID#	Last Location	Transmit Capability?		
2108 Service Area		Message _____		Rec'd	
2110 Button Format		-----		-----	
-----		-----		-----	
User 2	ID#	Last Location	Transmit Capability?		
Service Area		Message _____		Rec'd	
Button Format		-----		-----	
-----		-----		-----	
-----		-----		-----	

User Database

FIG. 22

2202	User 1	No. of Probe Signals Sent	No. of Registration Signals Received	No. of Messages Successfully Delivered	Other Traffic Data
2204	User 2	No. of Probe Signals Sent	No. of Registration Signals Received	No. of Messages Successfully Delivered	Other Traffic Data
2206	User 3	No. of Probe Signals Sent	No. of Registration Signals Received	No. of Messages Successfully Delivered	Other Traffic Data
2208	User 4	No. of Probe Signals Sent	No. of Registration Signals Received	No. of Messages Successfully Delivered	Other Traffic Data
2210	▪ ▪ ▪ ▪				

Traffic Database

FIG. 23

Service Queue

Current Messages		2300
ID#	Data Location	
2302		2308
2304		2310
2306		2312
⋮	⋮	
Probe List		
ID#	Data Location	
2314		2320
2316		2322
2318	⋮	2324

FIG. 24

2402	2404	2406	2408	2400
Base Transmitter 1	Zonal Assignment	Base Receivers in Coverage Area	Other Data	
Base Transmitter 2	Zonal Assignment	Base Receivers in Coverage Area	Other Data	
Base Transmitter 3	Zonal Assignment	Base Receivers in Coverage Area	Other Data	
Base Transmitter 4	Zonal Assignment	Base Receivers in Coverage Area	Other Data	
▪ ▪ ▪ ▪				

Base Transmitter Database

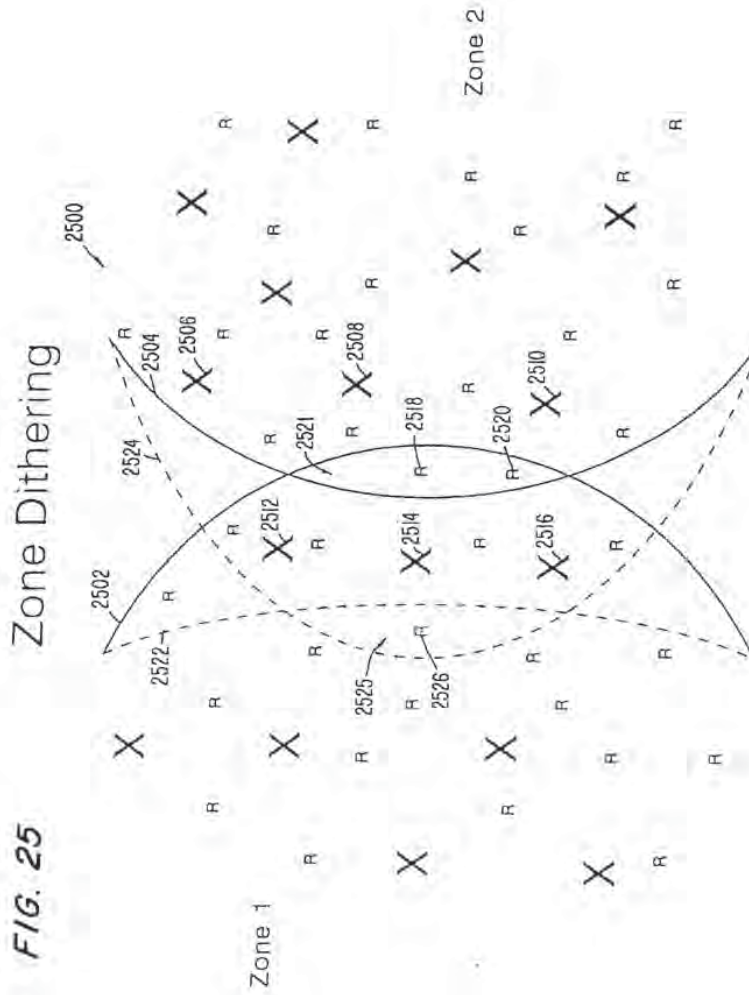
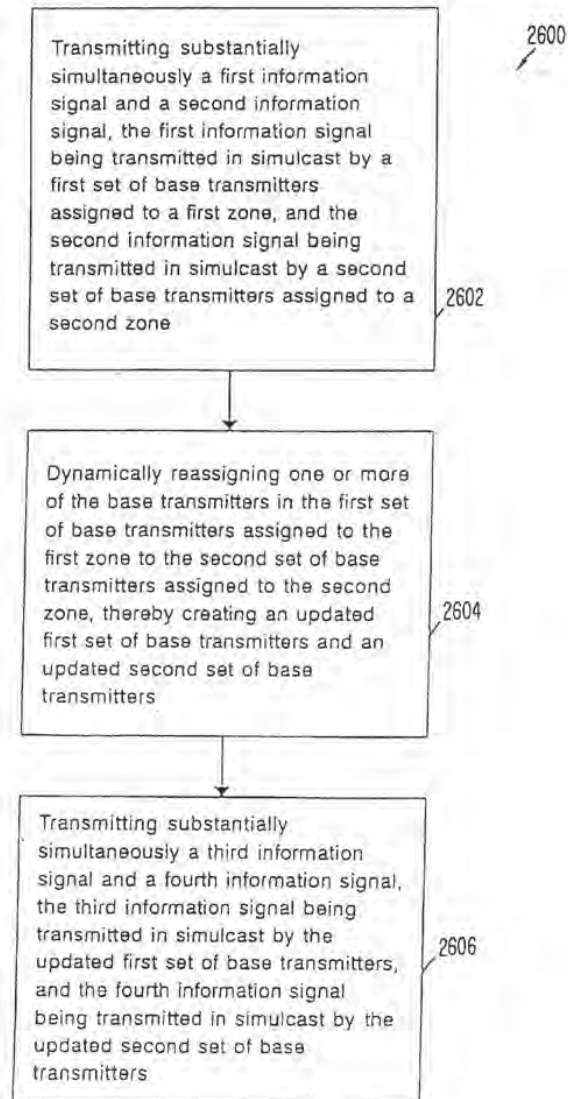

FIG. 26



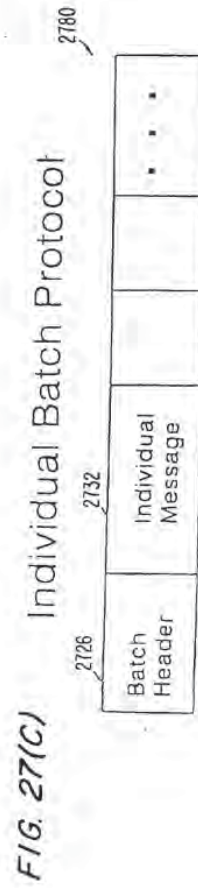
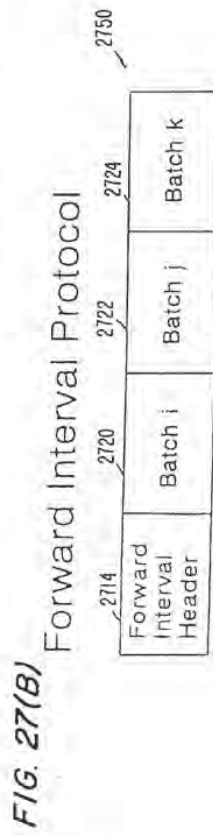
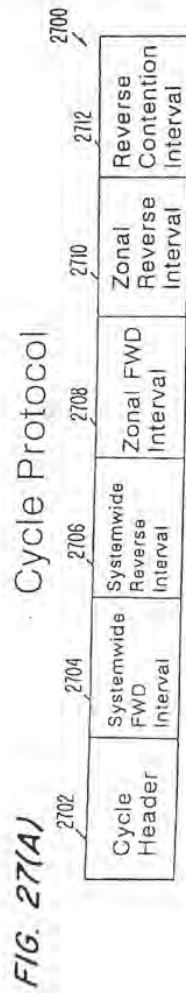

FIG. 28(A)

2800

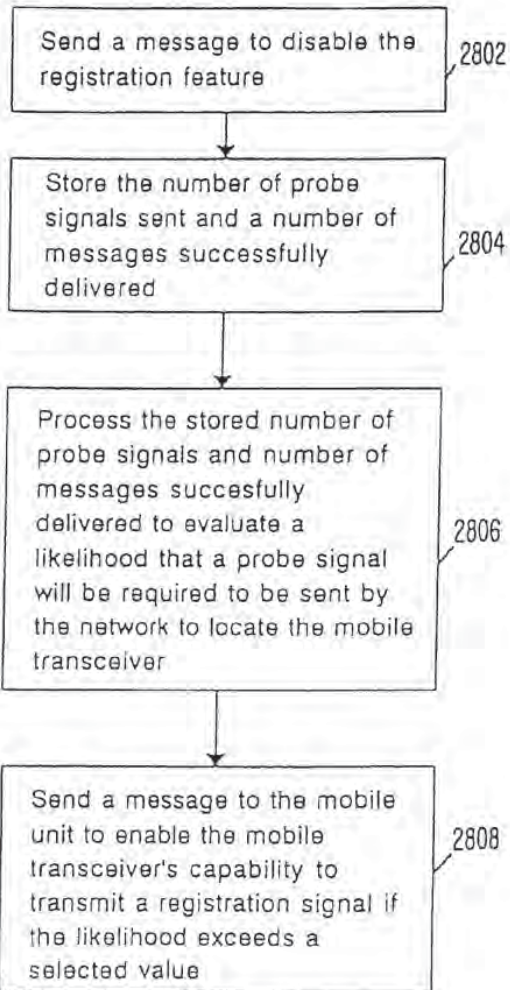

FIG. 28(B)

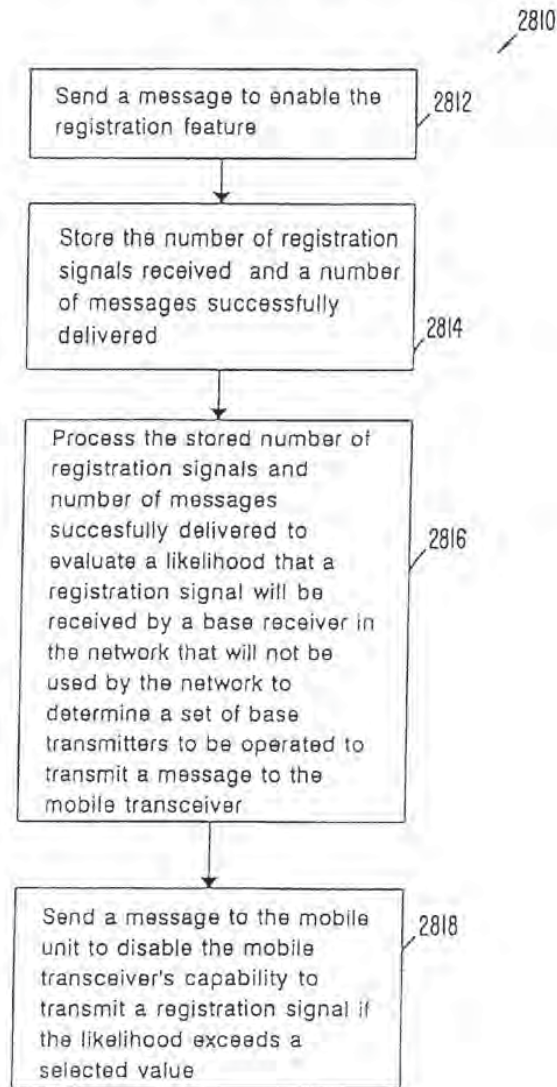

FIG. 29(A)

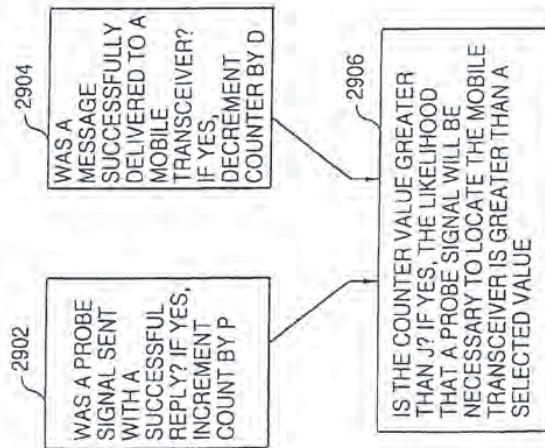
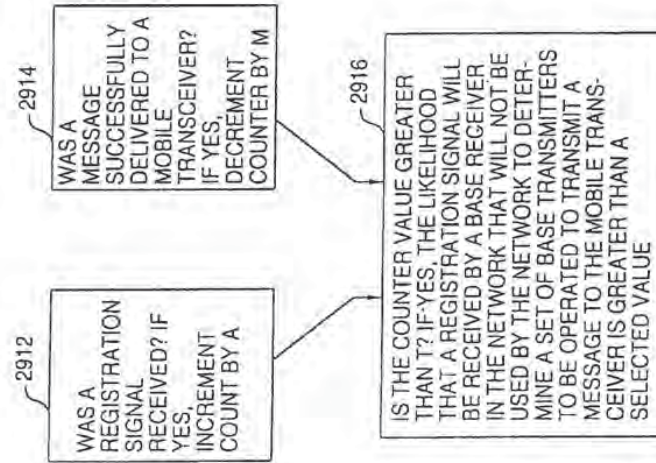

FIG. 29(B)



1

**METHOD AND SYSTEM FOR PROVIDING
MULTICARRIER SIMULCAST
TRANSMISSION**

This application is a continuation of application Ser. No. 08/760,457, filed Dec. 6, 1996, now abandoned, which is a Rule 60 continuation of prior application Ser. No. 07/973,918, filed Nov. 12, 1992, now U.S. Pat. No. 5,590,403.

BACKGROUND OF THE INVENTION

A. Field of the Invention

The present invention relates to methods and systems for providing two-way communication capability between a central network and a mobile unit over a relatively large area, and more particularly to such methods and systems which allow for rapid communication of large messages and efficient use of system resources.

B. Description of the Related Art

Conventional two-way portable/mobile wireless messaging systems often provide a variety of services to subscribers. Conventional messaging systems in particular provide one-way services using store and forward techniques to mobile receivers carried by the subscriber. A fundamental goal of two-way messaging systems is to provide a network of interconnected transmitters and receivers which provides sufficient transmitted signal strength and receive capability to uniformly cover a geographic region. Some conventional messaging systems provide the message to the user on a small viewing screen on the mobile unit.

However, such conventional systems often suffer from problems associated with low system throughput, evidenced by slow message delivery and message size limitations and do not provide an acknowledgment feature wherein the mobile unit transmits an acknowledgment signal to the system to acknowledge receipt of the message from the system. Generally, system throughput refers to overall communication capability of a system as defined by the total amount of message data from the system to the mobile units transferred by the system during a given period of time divided by the frequency bandwidth necessary to transmit the message data and may be measured in bits transferred per Hz. Further, such conventional systems suffer from technical problems preventing consistent wide area coverage and would require extremely wide portions of valuable frequency bandwidth to achieve acceptable system throughput rates.

Simulcast technology in communication systems was originally developed to extend transmitter coverage beyond that which could be obtained from a single transmitter. Over time, however, simulcasting has evolved into a technique capable of providing continuous coverage to a large area.

Generally, simulcast technology provides multiple transmitters, operating on substantially the same frequencies and transmitting the same information positioned to cover extended areas. As shown in FIG. 1, transmitter 100 generally provides coverage over area A, D, and E, transmitter 102 generally provides coverage over area B, D, and E, and transmitter 104 generally provides coverage over area C, E, and F. In some cases, the coverage area of a first transmitter may be entirely enclosed within the coverage area of another transmitter, such as in building interiors and valleys. In areas where one (and only one) transmitter dominates (e.g., areas A, B, and C in FIG. 1), simulcast is effective because the other transmitters do not significantly affect receivers in those areas.

However, in "overlap" areas D, E, and F shown in FIG. 1, where the signals from two or more transmitters are approxi-

2

mately equal, problems can arise because destructive interference of signals occurs in these overlap areas such as areas D, E, and F. Destructive interference occurs when the two signals are equal in magnitude and 180° out of phase and completely cancel each other. While there were some successes, reliable design procedures were not available.

Attempting to precisely synchronize the carrier frequencies of all simulcast transmitters does not overcome the problem because points (i.e. nodes) at which destructive summing occurred persisted for long periods of time. At such points, a mobile receiver can not receive the simulcast signal.

Deliberately offsetting the carrier frequencies of adjacent transmitters can ensure that destructive interference does not persist at one point for an extended period of time. The slight errors in frequency displayed by high quality reference oscillators (e.g., 20 hertz errors in 100 MHz signals or a few parts in 10⁷) render deliberate offsetting unnecessary. Further, merely offsetting the carrier frequencies could not guarantee acceptable quality demodulation because proper alignment of the modulating signals in time is also required.

FIG. 2 displays the situation at, for example, point D in FIG. 1 when modulating waveforms are synchronized and includes coverage boundary 202 from a first transmitter and a second transmitter coverage boundary 204 from a second adjacent transmitter. An equi-signal boundary 200 exists where the signals from the first and second transmitters have approximately equal signal strengths. A more realistic equi-signal boundary would take into account natural and man-made topography and propagation conditions, and therefore would probably not be a straight line.

FIGS. 3 and 4 generally illustrate various signals as they may occur at or near the equi-signal boundary 200 as shown in FIG. 2. In particular, FIGS. 3 and 4 illustrate various aspects of modulation synchronization and how altering transmission parameters may affect the synchronization. In general, there are at least three sources which cause the signals from the first transmitter and the second transmitter to be out of synchronization: (1) timing shifts in the delivery of the modulating waveform to each of the transmitters; (2) timing shifts internal to each transmitter; and (3) timing shifts caused by propagation distances and anomalies. From the perspective of a receiver located in an overlap area, these three sources of timing shifts combine to produce an overall timing shift between the received signals from the first and second transmitters. In current commercial practice, the summation of these three components results in time shifts of about 200 microseconds. The timing shift present in simulcast systems disadvantageously limits the baud rate at which information may be transferred. In general, FIGS. 3 and 4 will also illustrate how timing shifts prevents high baud rate transmissions.

A time line representation of a signal 306 from a first transmitter is shown in FIG. 3(A) and a signal 308 from a second transmitter is shown in FIG. 3(B), both from the perspective of a receiver located in an overlap area. Vertical dashed lines 300 represent baud intervals on the time axis. As can be seen from FIGS. 3(A) and (B), the signals 306 and 308 are frequency modulated between a high and a low frequency value and the signals 306 and 308 are exactly in phase. As will be appreciated, the timing shift between signals 306 and 308 must be small when compared to the baud interval shown in FIGS. 3(A) and (B) since signals 306 and 308 are in synchronization. Of course, as the baud interval decreases, the timing shifts will likely cause signals 306 and 308 to be out of synchronization.

FIGS. 3(C), (D), and (E) show the summation of these two signals 306 and 308 at an equi-signal boundary, such as boundary 200 in FIG. 2. FIG. 3(C) shows a composite signal 310 indicating that the frequency information remains unchanged, FIG. 3(D) shows a linear graph 312 of the relative phase difference caused by a slight carrier frequency difference between the signals from the first transmitter and the second transmitter. FIG. 3(E) shows a composite amplitude signal 314. A noise threshold is indicated by the horizontal dashed line 304 in FIG. 3(E).

Of interest, FIG. 3(E) shows the composite amplitude signal 314 dipping below the noise threshold 304 at an anti-phase condition 302 (e.g., when the relative phase angle is $\pm 180^\circ$, as shown in FIG. 3(D)). As can be seen from FIG. 3(E), the anti-phase condition 302 caused by the slight phase shift between transmitter 1 and transmitter 2 will not cause any loss of data because the anti-phase condition persists for only a small portion of the baud interval.

The slight offset of the carrier frequencies between the first and second transmitters causes a slow drift of the relative phase of the two signals, as shown in FIG. 3(D). When the signals are $\pm 180^\circ$ out of phase, the temporary dip in the amplitude signal may cause the loss of a few bits in the composite signal, at worst. These errors can be counteracted with a conventional error correcting code, such as is commonly known.

FIG. 4 shows a set of similar signals to those in FIG. 3, but wherein the signal 402 from the first transmitter is offset from, or out of synchronization with, the signal 404 from the second transmitter by a full baud. In particular, signal 404 lags signal 402 by one baud interval. As previously discussed, the offset of signals 402 and 404 may be caused by various timing shifts in the delivery of both signals 402 and 404 to a receiver in an overlap area. FIGS. 4(A) and (B) illustrate the extreme case where the sum of these timing shifts is equal to the baud interval shown by dashed lines 400. As can be seen in FIG. 4(C), composite signal 406 includes a period of indeterminate frequency which undesirably covers several entire baud intervals and, therefore, successful demodulation is impossible during those baud intervals. If the baud interval were increased to minimize the effect of these timing shifts, data loss would be less likely. Therefore, it can be seen that the baud rate at which good data transfer can be accomplished is limited by the timing shifts between signals delivered to receivers in overlap areas.

Through these examples, it can be seen that high degrees of modulation synchronization make it possible to obtain good data demodulation in a simulcast system. However, the baud rate limitation of simulcast systems is a significant drawback and limits system throughput.

An alternative to simulcast for wide area coverage is assignment of orthogonal, non-overlapping subdivisions of the available system capacity to adjacent areas. Subdivisions can be made in time (e.g., broadcasting the information on the same frequency in different time slots to adjacent areas), or in frequency (e.g., broadcasting the information simultaneously on different frequencies in adjacent areas). There are several problems with such orthogonal systems, however. First, orthogonal assignments require tuning the receiver to the assigned frequency or time channel for the area in which the receiver currently resides. In the broadcast services every traveler has experienced the frustration of finding the correct channel for their favorite programs. Simulcast operation avoids the need for scanning and re-tuning as the mobile unit moves between areas. Such scanning and re-tuning also disadvantageously increases mobile unit power consumption.

Second, and more serious, the orthogonal assignment approach drastically reduces the system throughput capacity as measured in bits per Hz because anywhere from 3 to 7, or possibly more, orthogonal assignments are required to obtain continuous area coverage in most conventional orthogonal systems. This waste of capacity is somewhat recouped if the same information is not needed throughout the service area because a given piece of information is sent only to those cells where it is needed.

Conventional cellular radio service is a typical example of an orthogonal system. In cellular, the same frequencies are reused in spatially separated cells to allow different data to be transmitted to different mobile units. An example of three cellular arrangements is shown in FIG. 5 where the number of cells (N) is equal to 3, 4, and 7. Each cell (i.e., A, B, C, . . .) in conventional cellular service usually only includes a single transmitter and operates in a different frequency or time division within the communication protocol. As shown in FIG. 5, cellular service generally locates transmitters utilizing the same division (all the "A" transmitters) far enough apart to reduce the likelihood of interference between such transmitters. As the number of cells increases, the likelihood of interference decreases. For example, with N=3 as shown by arrangement 500 in FIG. 3, the distance between the coverage area of "A" cells is about $\frac{1}{2}$ cell width, with N=4 in arrangement 502, the distance between the coverage areas of "A" cells is slightly larger, and with N=7 in arrangement 504 the distance between "A" cells is larger than the width of one cell.

However, as the number of cells increases, the length of the individual time intervals per cell decreases for time division multiplexed systems, thereby decreasing the systems total information transfer. In frequency division systems, more cells undesirably increases the frequency bandwidth required. Therefore, system throughput in bits per Hz is decreased as the number of cells increases. Furthermore, cellular systems often require an electronic "handshake" between system and mobile unit to identify the specific cell (i.e. transmitter) in which the mobile unit is located to allow capacity reuse.

II. SUMMARY OF THE INVENTION

The systems and methods of the present invention have a wide variety of objects and advantages. The systems and methods of the present invention have as a primary object to provide a communication system with wide area coverage and high message throughput while minimizing frequency bandwidth usage.

It is an object of the invention to provide a simulcast communication system with a high data transfer rate which does not exceed the baud rate limitations of simulcast transmission.

It is a further object of the present invention to provide a communication system which provides for superior data communication integrity.

Yet another object of the invention is to provide a mobile transceiver unit which prevents unnecessary RF interference, particularly on commercial aircraft. Still further, it is an object of the invention to provide a zone based communication system which may dynamically redefine zone boundaries to improve information throughput.

Another object of the invention is to provide a zone based simulcast communication system which can effectively communicate with both mobile transceiver units located near the center of each zone as well as mobile transceiver units located within the overlap areas between two or more zones.

5

Additional objects and advantages of the invention will be set forth in part in the description which follows, and in part will be obvious from the description, or may be learned by practicing the invention. The objects and advantages of the invention will be realized and attained by means of the elements and combinations particularly pointed out in the appended claims.

To achieve the objects and in accordance with the purpose of the invention, as embodied and broadly described herein, the invention is directed to a method for information transmission by a plurality of transmitters to provide broad communication capability over a region of space, the information transmission occurring during at least both a first time period and a second time period and the plurality of transmitters being divided into at least a first and second set of transmitters, the method comprising the steps of (a) generating a system information signal which includes a plurality of blocks of information, (b) transmitting the system information signal to the plurality of transmitters, (c) transmitting by the first and second sets of transmitters a first block of information in simulcast during the first time period, (d) transmitting by the first set of transmitters a second block of information during the second time period, and (e) transmitting by the second set of transmitters a third block of information during the second time period.

In another embodiment, the invention is directed to a multi-carrier simulcast transmission system for transmitting in a desired frequency band a message contained in an information signal, the system comprising a first transmitter means for transmitting an information signal by generating a first plurality of carrier signals within the desired frequency band and by modulating the first plurality of carrier signals to convey the information signal, and a second transmitter means, spatially separated from the first transmitter, for transmitting the information signal in simulcast with the first transmitter by generating a second plurality of carrier signals at substantially the same frequencies as the first plurality of carrier signals and by modulating the second plurality of carrier signals to convey the information signal.

In another embodiment, the invention is directed to a communication method implemented in a computer controlled communication network for locating a mobile transceiver within a region of space, the region of space being divided into a plurality of zones with each zone serviced by at least one base transmitter and at least one base receiver, the network storing data corresponding to a zone where the mobile transceiver was last known to be located, the communication method comprising the steps of (a) transmitting a message signal by a base transmitter servicing a zone where the mobile transceiver was last known to be located, (b) transmitting a systemwide probe signal by a plurality of base transmitters servicing a plurality of zones if the mobile transceiver does not indicate receipt of the message signal from the base transmitter, (c) receiving the regional probe signal by the mobile transceiver, (d) transmitting an acknowledgment signal by the mobile transceiver in response to the received regional probe signal, (e) receiving the acknowledgment signal from the mobile transceiver by a base receiver, and (f) updating the data to reflect the zone of the base receiver that received the acknowledgment signal as the last known location of the mobile transceiver.

In yet another embodiment, the invention is directed to a method of communicating messages between a plurality of base transmitters and mobile receivers within a region of space divided into a plurality of zones with each zone having at least one base transmitter assigned thereto, the commu-

6

nication method comprising the steps of (a) transmitting substantially simultaneously a first information signal and a second information signal to communicate messages to the mobile receivers, the first information signal being transmitted in simulcast by a first set of base transmitters assigned to a first zone, and the second information signal being transmitted in simulcast by a second set of base transmitters assigned to a second zone, (b) dynamically reassigning one or more of the base transmitters in the first set of base transmitters assigned to the first zone to the second set of base transmitters assigned to the second zone as a function of the messages to be communicated in an area, thereby creating an updated first set of base transmitters and an updated second set of base transmitters, and (c) transmitting substantially simultaneously a third information signal and a fourth information signal, the third information signal being transmitted in simulcast by the updated first set of base transmitters, and the fourth information signal being transmitted in simulcast by the updated second set of base transmitters to communicate additional messages to said mobile receivers.

In another embodiment, the invention is directed to a mobile transceiver unit for transmitting messages to and receiving messages from a network comprising input means for allowing the user to input a user message to the unit, transmitter means for transmitting a radio frequency signal including the user message from the mobile unit to the network, receiver means for receiving radio frequency signals having a message from the network, signal detector means for detecting at least one type of electromagnetic signal generated external to the mobile unit and the network, and a circuit, connecting the signal detector means to the transmitter means, for disabling the transmitter means upon detection of the electromagnetic signal, thereby preventing unwanted radio frequency transmission.

In another embodiment, the invention is directed to a communication method for controlling a mobile transceiver which may communicate with a communication network controlled by a computer, the network including a plurality of base transmitters for transmitting messages from the network to the mobile transceiver and base receivers for receiving messages from the mobile transceiver, the mobile transceiver being capable of sending a registration signal to be received by a base receiver in the network to identify the mobile transceiver's location and the plurality of base transmitters in the network being capable of sending a probe signal to the mobile transceiver to cause the mobile transceiver to transmit a signal to a base receiver to identify its location, the method comprising the steps of (a) sending a message from the network to the mobile transceiver to disable the mobile transceiver's capability to transmit a registration signal, (b) storing the number of probe signals sent by the network to the mobile transceiver during a first period of time and the number of messages successfully delivered to the mobile transceiver by the network during a second period of time, (c) processing by the computer the stored number of probe signals and number of messages successfully delivered to evaluate a likelihood that a probe signal will be required to be sent by the network to locate the mobile unit to deliver a message, and (d) sending a message to the mobile unit to enable the mobile transceiver's capability to transmit a registration signal if the calculated likelihood exceeds a selected value.

Finally, in another embodiment, the invention is directed to a communication method for controlling a mobile transceiver which may communicate with a communication network controlled by a computer, the network including a

7

plurality of base transmitters for transmitting messages to the mobile transceiver and base receivers for receiving messages from the mobile transceiver, the mobile transceiver being capable of sending a registration signal to be received by a base receiver in the network to identify the mobile transceiver's location, the network using received registration signals to determine a set of base transmitters to be operated to transmit a message to the mobile transceiver, the method comprising the steps of (a) sending a message from the network to the mobile transceiver to enable the mobile transceiver's capability to transmit a registration signal, (b) storing the number of registration signals from the mobile transceiver to the network during a first period of time and the number of messages successfully delivered to the mobile transceiver by the network during a period of time, (c) processing the stored number of registration signals and number of messages successfully delivered to evaluate a likelihood that a registration signal from said mobile unit will not be used by the network to determine a set of base transmitters, and (d) sending a message to the mobile unit to disable the mobile transceiver's capability to transmit a registration signal if the likelihood exceeds a selected value.

It is to be understood that both the foregoing general description and the following detailed description are exemplary and explanatory only and are not restrictive of the invention, as claimed.

III. BRIEF DESCRIPTION OF THE DRAWINGS

The accompanying drawings, which are incorporated in and constitute a part of this specification, illustrate several embodiments of the invention and together with the description, serve to explain the principles of the invention.

FIG. 1 is a schematic diagram of an arrangement of simulcast transmitters;

FIG. 2 is a schematic diagram of uniform smooth earth propagation;

FIG. 3 is a schematic diagram of synchronized modulated waveforms;

FIG. 4 is a schematic diagram of modulated waveforms offset a full baud;

FIG. 5 is a schematic diagram of cellular system coverage;

FIG. 6 is a schematic diagram of a communication system;

FIG. 7 is a flow chart of a preferred method of communication;

FIG. 8 is a flow chart of a preferred method of sending a regional probe signal;

FIG. 9 is a schematic diagram of a frequency spectrum for multi-carrier modulation;

FIG. 10 is a schematic diagram of an on/off keying modulator;

FIG. 11 is a schematic diagram of a frequency shift keying modulator;

FIG. 12 is a schematic diagram of a four carrier quadrature modulator;

FIG. 13 is a schematic diagram of a first embodiment of a base transmitter;

FIG. 14 is a schematic diagram of a second embodiment of a base transmitter;

FIG. 15 is a schematic diagram of a mobile transceiver;

FIG. 16 is a pictorial representation of a mobile transceiver;

FIG. 17 is a schematic diagram of a mobile receiver;

8

FIG. 18(A) is a schematic diagram of an analog base receiver;

FIG. 18(B) is a schematic diagram of a digital base receiver;

FIG. 19 is a schematic diagram of a base receiver with a store and forward feature;

FIG. 20 is a schematic diagram of a network operations center;

FIG. 21 is a schematic diagram of a database structure;

FIG. 22 is a schematic diagram of a traffic database;

FIG. 23 is a schematic diagram of a service queue;

FIG. 24 is a schematic diagram of a base transmitter database;

FIG. 25 is a schematic diagram of dynamically changing zonal assignments;

FIG. 26 is a flow chart of a preferred method of dynamically zonal reassignment;

FIG. 27(A) is a schematic diagram of the cycle protocol;

FIG. 27(B) is a schematic diagram of the forward batch interval protocol;

FIG. 27(C) is a schematic diagram of the individual batch protocol;

FIG. 28(A) is a flow chart of a preferred method to enable the registration feature of a mobile unit;

FIG. 28(B) is a flow chart of a preferred method to disable the registration feature of a mobile unit;

FIG. 29(A) is a flow chart of a preferred evaluation method used to enable the registration feature; and

FIG. 29(B) is a flow chart of a preferred method used to disable the registration feature.

IV. DESCRIPTION OF THE PREFERRED EMBODIMENTS

Reference will now be made in detail to the present preferred embodiments and exemplary embodiments of the invention, examples of which are illustrated in the accompanying drawings. Wherever possible, the same reference numbers will be used throughout the drawings to refer to the same or like parts.

A. Overview of The System Hardware

FIG. 6 shows an overview of the major elements of a preferred communication system according to the present invention. As shown therein, the communication system includes a network operations center 600 which is connected to a satellite uplink 602 via data path 604. A satellite uplink is used to provide data to satellite 606. Satellite 606 redirects the received data to several satellite downlink stations including station 608 and station 610. Conventional satellite technology allows for nominal data transfer rates of 24 M bits/second. Further, conventional satellite technology allows for accurate delivery of data to stations 608 and 610, which allows for precise synchronization between the signals broadcast in simulcast by the stations 608 and 610. It should be understood that stations 608 and 610 may optionally receive identical data, or may individually receive different data simultaneously from the satellite 606.

Satellite downlink stations 608 and 610 are connected to spatially separated base transmitters 612 and 614 via data paths 616 and 618, respectively. Base transmitter 612 is connected to antenna 620, and base transmitter 614 is connected to antenna 622. Preferably, the base transmitters of the present system have a power output capability of

about 350 watts, which will provide an effective transmitter coverage area of several tens of miles. Each zone preferably includes multiple transmitter stations shown as, for example, base transmitters 613 and 615 in FIG. 6 as will be evident from the following discussion.

Mobile unit 624 is connected to antenna 626 and, in the preferred embodiment, is a small, portable unit capable of being carried easily by a user and therefore is similar to conventional pagers in those aspects. More preferably, the mobile unit has both receive and transmit capability, with a nominal transmit power output of about 1 watt.

The communication system includes several base receivers 628, 630, 632, and 634 each connected to antennas 636, 638, 640, and 642, respectively. Base receivers 628 and 630 are connected to a regional station 644 via data paths 646 and 648, respectively. Base receivers 632 and 634 are connected to regional station 650 via data paths 652 and 654, respectively. Base transmitters 612, 614 preferably have a large transmit power output capability to provide coverage to the mobile unit in areas to which communication is typically difficult, such as building interiors, and to extend the coverage area of each transmitter. An appropriate number of base receivers should be dispersed throughout the geographic area to reliably receive the signals from the mobile unit. Due to the difference in output power between base transmitters and mobile units, an overall ratio of 10 base receivers to 1 base transmitter may be appropriate, and the 2 to 1 ratio shown in FIG. 6 is merely shown for ease of illustration.

Regional station 650 is connected to the network operations center 600 via data path 656 and regional station 644 is connected to the network operations center 600 via data path 658. The data paths 656 and 658 preferably include low cost phone lines, but may include any convenient and appropriate data transfer technology. Generally, the communication system of the present invention roughly divides various regions of space into portions called zones. Each zone must have one or preferably more base transmitters assigned to it. Zone boundaries are roughly defined by the transmitter coverage areas of the base transmitters assigned to that zone. For example, FIG. 6 shows a dashed zone dividing line 660 roughly dividing a zone 1 from a zone 2. Zone 1 includes base transmitter 614, base receivers 632 and 634, regional station 650, and mobile unit 624. Zone 2 includes base transmitter 612, base receivers 628 and 630, and regional station 644. Dashed line 660 only roughly defines the boundary between zones because precise boundaries do not exist. For example, to insure adequate coverage of the region, as shown in FIG. 1, the range of both transmitter 614 should at least cover the region above dashed line 660, and preferably should extend somewhat below dashed line 660. Similarly, the range of base transmitter 612 should at least cover the region below dashed line 660, and preferably should extend somewhat above dashed line 660. As can be seen, an overlap of transmitter coverage may occur in the vicinity of dashed line 660.

Referring back to FIG. 2, it can be seen that boundary 202 and boundary 204 overlap in an area near the equi-signal 200 and between these boundaries which may be termed an "overlap area." In FIG. 6, dashed line 660 is drawn near the may be defined as the equi-signal boundary between base transmitter 614 and base transmitter 612. Of course, dashed line 660 does not represent the overlap area that may occur between base transmitter 614 and base transmitter 612.

As explained in the Background of the Invention section, if base transmitters 612 and 614 are broadcasting identical

signals on the same frequencies in simulcast, good reception by a receiver located near the dashed line 660, and possibly in an overlap area (not shown), can be achieved. Simulcast thus may provide uniform transmitter coverage for the region shown in FIG. 6. However, if base transmitter 612 is broadcasting a first information signal and base transmitter 614 is broadcasting a different, second information signal on identical frequencies simultaneously, it will likely be difficult for a receiver located in the overlap area to receive either the first or the second information signal. In this instance, the overlap area may be referred to as an interference area because a receiver in this area would receive a composite signal, including the first and second information signal, that would likely be unusable.

The following will be an exemplary discussion of the various interactions of the elements of the communication system when delivering a message to mobile unit 624. In accordance with the invention, a preferred method 700 of this interaction is shown in

FIG. 7. Network operations center 600 generates a system information signal of several blocks of information as shown in step 702. The blocks of information include an electronic message to be delivered to the mobile unit 624.

In step 704, the system information signal is transmitted to the base transmitters. In particular the network operations center 600 provide the system information signal and appropriate other data to the satellite uplink 602 via data path 604 for transmission to the satellite 606. The data is then received and retransmitted by satellite 606 to satellite downlink stations 608 and 610. The data received by satellite downlink 608 is provided to base transmitter 612 through data path 616, and the data received by satellite downlink 610 is provided to base transmitter 614 through data path 618.

At this point, the exemplary communication system shown in FIG. 6 may transfer the message to the mobile unit during one of two time intervals. In the first time interval, both base transmitter 612 and base transmitter 614 transmit data via antenna 620 and antenna 622, respectively, in simulcast to be received by mobile unit 624, which corresponds to step 706 in FIG. 7. This first alternative may be useful to deliver the message if, for example, the location of mobile unit 624 in zone 1 or zone 2 is unknown and broad coverage is desired.

In the second time interval, base transmitter 614 transmits a block of information including the message data to mobile unit 624 and base transmitter 612 transmits another block of information, which corresponds to steps 708 and 710 of FIG. 7. This second alternative may be useful if, for example, the mobile unit 624 is known to be located in zone 1 and out of range of base transmitter 612. Delivery of the message to mobile unit 624 during the second time interval is advantageous because during message delivery to the mobile unit 624 by base transmitter 614, base transmitter 612 could be delivering a different message to a different mobile unit (not shown). As can be seen, this second alternative would increase information throughput and system efficiency.

If the mobile unit 624 has properly received the message via antenna 626, then the mobile unit 624 may generate a return signal Hand broadcast that signal via antenna 626. The return signal may be received by any or several of the base receivers 628, 630, 632, or 634. For example, the return signal could be received by base receiver 632 through antenna 640 if antenna 640 is located closer to the mobile units than any other antenna 636, 638, or 642. In this case, the base receiver would receive the return signal and provide

11

it to regional station 650 through data path 652. The regional station would then provide the return signal to the network operations center 600 through data path 656 for further processing as appropriate. It should be understood that a return signal may include either an autonomous acknowledgment signal which indicates that the mobile unit accurately received the message or a user generated reply signal.

If the mobile unit 624 does not completely receive the message, it can generate and broadcast a negative acknowledgment signal. The negative acknowledgment signals when delivered to the network operations center 600, indicates that retransmission of the message is necessary.

It should be understood that the exemplary system shown in FIG. 6 includes a modest number of elements for ease of explanation. It is envisioned that the system of the present invention include a large number of base transmitters, base receivers, regional stations, and mobile units with a substantial number of base transmitters assigned to each zone and all base transmitters assigned to a particular zone operating in simulcast. Further, it is envisioned that the present system could advantageously support a large number of zones to cover a wide geographic area.

B. Overview of the Zonal Simulcast Concepts

The preferred systems and methods of the present invention variously use simulcast techniques within individual zones and over several or all of the zones. As previously noted, zones are generally defined by the coverage areas of the one or more base transmitters. The network operations center 600 assigns each base transmitter in the system to a zone. For example, in FIG. 6, base transmitter 614 is assigned to zone 1, and the base transmitter 612 is assigned to zone 2 by the network operations center 600. To maximize information throughput, the systems and methods of the present invention dynamically control zonal assignments and the use of simulcast techniques.

In general, the communication system of the present invention operates by repeating a communication cycle to achieve desired information transfer, which is more fully discussed infra. The communication cycle is divided into a systemwide time interval and a zonal time interval. In the systemwide time interval, the base transmitters from at least several zones are operated in simulcast to simultaneously transmit identical information to a large geographic area. It should be understood that the systemwide time merely two or more zones.

Broadly speaking, the communication system need not know the location of a mobile unit to transmit to it during the systemwide time interval. Therefore, the systemwide time interval can be used to send a "probe" signal that requests a particular mobile unit to broadcast an acknowledgment signal to allow the system to determine its approximate location by determining which base receiver receives the acknowledgment signal. Probe signals, thereby, may be used to track the locations of mobile units, or to uncover the location of "lost" mobile units.

In the zonal time interval, each base transmitter assigned to a particular zone transmits identical information in simulcast. However, for mobile units at or near the interference areas between adjacent zones, poor communication to those mobile units is likely during the zonal time interval because transmitters in adjacent zones will be simultaneously transmitting different data on the same, or substantially the same, frequencies. The zonal time interval provides good communication capability for mobile units not located near the zonal boundaries and allows the system to "reuse" identical

12

frequencies in adjacent zones. Furthermore, if zonal boundaries are selected to be located in areas where mobile units are not likely to be located, i.e. unpopulated areas, the likelihood of providing good communication capabilities to a large percentage of mobile units can be increased.

As can be seen, from a system perspective, it is desirable to communicate with the mobile units in the zonal time interval because information throughput is maximized by reusing the transmission frequency band in the several zones. In other words, using the zonal time interval allows communication with a large number of mobile units in a short amount of time. Accordingly, communication during the systemwide time interval should be minimized because message transmission during this interval requires a large amount of system resources be dedicated to that message.

For mobile units located near the boundaries between zones where interference is likely during the zonal time interval, good communication capability can be achieved for these units during the systemwide time interval. In the preferred systems and methods, when a mobile unit fails to acknowledge a message sent during the zonal time interval or provides a negative acknowledgement, the network operations center sends a probe signal during a subsequent systemwide time interval to determine the location of that mobile unit. If the location of the mobile unit indicates that a likely reason for the failure of the mobile unit to receive the message is caused by inter-zonal interference, the network operations center may simply retransmit the message during the systemwide time interval. In other instances, the failure to successfully deliver a message may be simply caused by the mobile unit being located in a weak signal area within a zone. In these instances, the system may retransmit the message during the zonal time interval using an appropriate error correcting code or using a stronger error correcting code.

Alternatively, the network operations center may determine from the probe signal that the mobile unit is simply located in a different zone than the zone that the message was first sent. In this case, the network operations center preferably causes the message to be retransmitted in the appropriate zone without again using a portion of the valuable systemwide time interval.

In accordance with the invention, a preferred method 800 for sending a probe signal is shown in FIG. 8. In step 802, a message signal is transmitted by a base transmitter servicing a zone where the mobile transceiver was last known to be located. In particular, this may be preferably an attempt by the network to deliver a message to the mobile transceiver.

If the mobile transceiver does not indicate receipt of the message signal from the base transmitter transmitted in step 802, the network assumes that the mobile transceiver has not received the message and transmits a probe signal by a plurality of base transmitters servicing a plurality of zones in step 804. The mobile transceiver receives the probe signal in step 806.

Upon receipt of the probe signal by the mobile transceiver, the mobile transceiver transmits an acknowledgment signal in step 808. A base receiver receives the acknowledgment signal from the mobile transceiver in step 810.

Finally the data, such as the last location field 2104 shown in user database 2100, is updated to reflect the zone of the base receiver, or receivers, that receives the acknowledgment signal as the last known location of the mobile transceiver in step 812.

13

C. The Multi-Carrier Modulation Transmission Format

The base transmitters of the communication system, such as base transmitters 612 and 614 shown in FIG. 6, preferably utilize a multi-carrier modulation format as will now be described. In general, a multi-carrier modulation format envisions the simultaneous transmission of several closely spaced carrier frequencies within a desired frequency band, each individually modulated to convey an information signal. The multi-carrier modulation format advantageously allows for high data transfer rates by providing good bit rate transmission rates while keeping below the baud rate limitations of simulcast transmission techniques.

FIG. 9 shows a frequency representation 900 of an eight carrier modulation format. Carrier frequency 902 is shown with side bands 904, carrier frequency 906 is shown with side bands 908, carrier frequency 910 is shown with side bands 912, carrier frequency 914 is shown with side bands 916, carrier frequency 918 is shown with side bands 920, carrier frequency 922 is shown with side bands 924, carrier frequency 926 is shown with side bands 928, and carrier frequency 930 is shown with side bands 932.

It should be understood that although this exemplary figure shows an eight carrier signal modulation format, other different numbers of carrier frequencies may be considered for use in the systems and methods of the present invention.

In this exemplary embodiment, the carrier frequencies are spaced 3 KHz apart within a desired frequency band of 50 KHz. Dashed line skirts 934 and 936 represent minimum frequency roll off levels, such as may be required by Federal Communication Commission regulations, to prevent overlap interference into adjacent frequency bands.

Because eight unique data streams may be modulated onto the respective eight carrier signals in this embodiment, the data transfer rate of the transmission from the base transmitters can be greatly increased, while keeping the baud rate within acceptable ranges for simulcast transmission. It should also be understood that in accordance with good simulcast practice, the respective carrier frequencies between adjacent base transmitters, such as base transmitter 612 and base transmitter 614 in FIG. 6, should be slightly offset to prevent sustained nodes or "dead spots" where destructive interference between the signals from each transmitter provides an unusable composite signal, as was explained in the background section of this application. This frequency offset is preferably on the order of 10-20 hertz.

As previously discussed, each carrier signal may be individually modulated to convey a data stream. The following will discuss alternative techniques for modulating a plurality of carriers in accordance with the systems and methods of the present, invention.

1. Modulated On/Off Keying

Perhaps the simplest modulation scheme conceptually is modulated on/off keying (MOOK). FIG. 10 shows a schematic representation of a MOOK modulator 1000. The MOOK modulator 1000 includes a plurality of carrier frequency generating devices, such as frequency generator 1002 generating frequency F1, frequency generator 1004 generating frequency F2, frequency generator 1006 generating frequency F3, frequency generator 1008 generating frequency F4, and frequency generator 1010 generating frequency Fn. As shown in FIG. 10, the MOOK modulator 1000 may include any number (i.e. n) of frequency generators, but eight carrier frequencies are preferred, as shown in FIG. 9.

14

The output from each of the carrier frequency generators 102, 104, 106, 108, and 110 is applied to a plurality of respective switches SW1 812, SW2 814, SW3 816, SW4 818, and SWn 820. The output from each switch is provided to a combiner 1022.

Each of the switches SW1 812, SW2 814, SW3 816, SW4 818, and SWn 820 opens and closes under the control of a control logic system (not shown) to effect the MOOK modulation. The control logic system (not shown) causes the desired switches to variously close and open, thereby conveying an n-bit binary word. Each carrier frequency transmits a binary "one" if the respective switch is closed and a binary "zero" if the respective switch is

The summer 1022 combines the modulated carrier frequencies to provide a multi-carrier modulated output signal that conveys an n-bit binary word.

2. Binary Frequency Shift Keying Modulation

An alternative multi-carrier modulation scheme including frequency shift keying (FSK) techniques may be implemented by the modulator shown in FIG. 11. A frequency shift keying modulator 1100 includes a first frequency source 1102, a second frequency source 1104, a third frequency source 1106, a fourth frequency source 1108, and an nth frequency source 1110. The output from each frequency source is provided to a respective modulator 1112, 1114, 1116, 1118, and 1120.

A control logic system (not shown) provides a frequency control signal to each modulator to frequency shift modulate the carrier frequencies. In particular, the control logic system (not shown) provides frequency control signal 1 to modulator 1112, frequency control signal 2 to modulator 1114, frequency control signal 3 to modulator 1116, frequency control signal 4 to modulator 1118, and frequency control signal n to modulator 1120. In binary frequency shift keying (BFSK), the respective frequency control signals provide data corresponding to a binary "one" or "zero" which causes the respective modulators to modulate a first or second frequency onto the carrier signal.

A summer 1122 combines the modulated carrier frequencies to produce an output signal.

3. M'ary Frequency Shift Keying Modulation

A modulation scheme related to binary frequency shift keying is M'ary frequency shift keying. M'ary frequency shift keying modulates three or more different frequencies onto the respective carrier signals. In quaternary frequency shift keying, for example, two bits of information may be instantaneously conveyed on a single carrier frequency. Similarly, 8'ary frequency shift keying may instantaneously convey three bits of information per carrier frequency.

Referring again to FIG. 11, M'ary frequency shift keying may be implemented by providing modulators 1112, 1114, 1116, 1118, and 1120 with the capability to modulate M different frequencies onto the carrier signal. Accordingly, the various frequency control signals must provide data indicating which of the M frequencies is to be modulated onto the carrier signal. For example, in quaternary frequency shift keying, the frequency control signals must each include two bits of information to indicate which of the four different frequencies are to be modulated onto the carrier frequency.

The summer 1122 combines the modulated carrier frequencies to produce an output signal.

4. Quadrature Amplitude Multi-Carrier Modulation

Yet another alternative modulation technique for a multi-carrier transmission format is shown in FIG. 12. A quadra-

15

ture modulator 1200 includes a first quadrature carrier generator 1202, a second quadrature carrier generator 1204, a third quadrature carrier generator 1206, and a fourth quadrature carrier generator 1208. As is well known, quadrature modulators in general each produce an in-phase carrier signal and a quadrature carrier signal that is $\pm 90^\circ$ out of phase with reference to the in-phase signal. Of course, any number of quadrature carrier generators could be envisioned, depending upon data transfer and throughput needs. FIG. 12 shows four quadrature carrier generators which effectively correspond to eight unique modulator signals. Therefore, quadrature amplitude multi-carrier modulation may preferably reduce the width of the frequency band necessary to achieve a desired data transfer rate.

Each quadrature carrier generator 1202, 1204, 1206, and 1208 receives a control signal from a control logic system (not shown) which provides the data to be modulated onto the quadrature carrier signals. In a simple implementation, the quadrature carrier generators may amplitude modulate the in-phase and quadrature phase output signals to convey two bits of information. The in-phase and quadrature signals output from each quadrature carrier generators 1202, 1204, 1206, and 1208 are provided to a summer 1210 which combines the signals to produce an output signal.

5. Permutation Frequency Shift Keying (PFSK)

PFSK may be implemented through control logic systems similar to that used in a MOOK or an M'ary FSK modulation scheme. In PFSK, every baud has a fixed number of carrier signals present, preferably any 4 of the possible 8. In a PFSK arrangement, a constant average transmitter power is advantageously delivered and the receiver only need decide which 4 carrier frequencies contain the most energy. In the case of MOOK, the receiver must attempt to determine on a subchannel-by-subchannel basis the presence or absence of a signal. This aspect of PFSK may simplify mobile receiver design.

Compared to a binary or M'ary FSK modulation schemes, a higher number of bits may be delivered per baud with PFSK. For example, PFSK may generate signals that independent FSK subchannels could never generate, such as all four carriers being the four highest frequencies, and therefore it can be seen that PFSK may advantageously increase information transfer rates.

D. The Base Transmitter

Each base transmitter unit, such as base transmitter 612 or 614 shown in FIG. 6, receives transmitter control data and message data transmitted from the satellite 606. FIG. 13 shows a first preferred embodiment of a base transmitter 1300 in accordance with the present invention. The base transmitter 1300 receives data from the satellite downlink connected to data input 1302 which provides this data to a control logic system 1304 to control the operation of the base transmitter unit. The control logic 1304 provides a control signal to a plurality of modulators 1306, 1308, 1310, 1312, and 1314. Modulator 1306 produces a carrier signal F1, modulator 1308 produces a carrier signal F2, modulator 1310 produces a carrier signal F3, modulator 1312 produces a carrier signal F4, and modulator 1314 produces a carrier signal Fn.

For example, the control logic may generate appropriate control signals to modulate the carrier signals in a MOOK, BFSK, M'ary FSK, PFSK, or quadrature amplitude modulation scheme, as previously discussed. Each modulator then

16

provides the modulated output signal to a combiner 1316 which combines each of the several modulated carrier frequencies into a single output signal.

The single signal is then applied to a power amplifier 1318 to amplify this signal to an appropriate level. The power amplifier 1318 may, for example, produce a nominal output signal of 350 watts to antenna 1320. In this embodiment, power amplifier 1318 preferably has extremely linear characteristics to prevent formation of intermodulation products, and to insure that these intermodulation products do not cause signals to be generated at undesirable frequencies. Antenna 1320 broadcasts the desired signal from power amplifier 1318.

FIG. 14 shows a second preferred embodiment of a base transmitter unit. The second embodiment comprises a base transmitter 1400 which includes a satellite downlink connected to data input 1402, control logic 1404, and several modulators 1406, 1408, 1410, 1412, and 1414. Each modulator receives an appropriate control signal from the control logic 1404, as previously discussed with respect to base transmitter 1300.

The output from each of modulators 1406, 1408, 1410, 1412, and 1414 in base transmitter 1400 is provided to respective power amplifiers 1416, 1418, 1420, 1422, and 1424 to provide an appropriate power output level for transmission, such as 350 watts aggregate.

The output from each of power amplifiers 1416, 1418, 1420, 1422, and 1424 is provided to combiner 1426 to combine the modulated carrier signals into a single output signal which is provided to antenna 1428 for broadcast.

E. The Mobile Unit

The mobile unit may be a small, portable mobile transceiver, such as pictorially represented in FIG. 16. Referring now to FIG. 15, the mobile transceiver 1500 shown therein includes a receiver section for receiving signals from the base transmitters of the system, and a transmitter section for transmitting replies, or other messages, to the base receivers of the system.

In particular, the mobile transceiver 1500 includes an antenna 1502 which is connected to a transmit/receive switch 1504 to switch the antenna between the transmit and receive sections of the mobile transceiver 1500. A receiver 1506 is provided to receive the messages from the base transmitter. Of course, the receiver must be appropriately designed to receive the multi-carrier signals from the base transmitters and must be appropriately designed to demodulate the particular modulation scheme utilized. For example, appropriate analog filters and appropriate demodulators could be used. In the preferred embodiment, the receiver performs a transform, such as a fast fourier transform, on the received signal to separate the data from the various carriers in the multi-carrier modulation format.

The receiver 1506 is connected to a display and storage logic section 1508 to process the received signal. An annunciator 1510 to alert the user that a message has been received is connected to and controlled by the display and storage logic 1508. The annunciator 1510 may commonly include a sound producing device such as a beeper, or a vibrator, or a flashing light.

A set of display controls 1512 to control the display of the mobile transceiver 1500 is connected to the display and storage logic 1508. A display 1514, preferably an LCD display, is also connected to the display and storage logic 1508 to display messages and various other information to the user.

17

Display and storage logic 1508 is connected to transmit logic 1518 via connection 1526. Display and storage logic 1508 may generate an autonomous acknowledge signal which causes the transmitter 1520 to broadcast an appropriately modulated RF signal. As previously discussed, it is desirable for the mobile transceiver to transmit an acknowledge signal if the message was properly received by the mobile unit, or alternatively to transmit a negative acknowledge signal if the message was only partially received. The negative acknowledge signal indicates that the network operations center should rebroadcast the message to the mobile unit.

Preferably, the rebroadcast of the message to the mobile unit should occur with an appropriate error correcting code which may be decoded by the mobile unit to insure complete and accurate reception of the message. Of course, error correcting codes should be used only when necessary because their use slows data transfer and increases the complexity of the mobile unit. Other types of autonomous replies may also be useful, for example, to indicate to the network operations center that the user has not viewed the message even though the mobile unit properly received it, such as when the mobile transceiver is unattended by the user.

A set of input switches 1516 is provided to allow the user to:

input a reply to a received message, or to otherwise generate a message to be transmitted by the mobile transceiver. The input switches are connected to transmit logic 1518 which decodes the signal from the input switches 1516 to generate an output signal to the transmitter 1520. The transmitter 1520 generates an appropriately modulated RF signal to be broadcast by antenna 1502.

The mobile transceiver 1500 also preferably includes a noise detector 1522. The noise detector 1522 provides an output signal upon sensing through antenna 1502 a threshold level signal. The noise detector 1522 provides an output signal to disable the transmitter 1520 via connection 1524, and to thereby prevent unwanted transmission by the mobile unit.

Noise detector 1522 preferably is set to detect electromagnetic signals which are generated externally to the communication system and which are indicative of a condition when transmissions by the mobile unit are undesirable. For example, the noise detector 1522 could be designed to serve a threshold level of noise at 400 Hz. When the user enters a commercial aircraft, which commonly uses 400 hertz power supply, the receipt of this noise by the noise detector 1522 would then disable the transmit capability of the mobile transceiver 1500 during operation of the aircraft to prevent any unnecessary or unwanted interference with the operations of the aircraft by autonomous or intentional transmissions by the mobile transceiver 1500.

The display and storage logic 1508 of the mobile transceiver 1500 further preferably includes a timing circuit (not shown) which may be used to turn the receiver section 1506 on or off, as desired. The timing circuit (not shown) advantageously allows the mobile transceiver to "power down" during periods of time when messages are not anticipated to be transmitted. For example, in a preferred communication protocol, the receiver could simply power up at the beginning of each cycle to receive data to determine if a message will be transmitted to that mobile transceiver during that cycle or when information concerning message availability will be transmitted. If the mobile transceiver is to receive a message, the timing circuit could power up at the appropri-

18

ate time to receive the message, and then power down after receipt. The timing circuit, therefore, advantageously prolongs the battery life of the mobile transceiver 1500. Of course, it should be understood that the timing circuit could control the other elements of the mobile transceiver, such as the display 1514, and the transmit logic 1518.

In an alternate implementation, the receiver 1506 may adaptively change its demodulation techniques to accommodate various formats. For example, each zone may advantageously use a different modulation format depending on message traffic levels, and other considerations. In particular, the receiver may receive a signal indicating the modulation scheme utilized in a given zone via a modulation format message contained in an overhead portion of the data stream. The demodulation of FSK, M'ary FSK, PFSK, and MOOK formats all begin with the determination of the energy levels detected at each of the carrier frequencies, and thus require identical processing of the received RF energy. The logic (not shown) in the receiver interprets the meaning of these measured energy levels based upon the modulation scheme selected as indicated by the received modulation format message. In this manner simpler and more economical transmitters, with a decreased capacity for information transfer, can be used in zones that have decreased traffic loads and more expensive, high-throughput transmitters can be used only in those areas where they are needed.

A pictorial representation of the mobile transceiver is shown in FIG. 16. The mobile transceiver 1600 shown therein includes a case 1602, a pair of display control buttons 1604, a display 1606, and a set of six reply buttons 1608, 1610, 1612, 1614, 1616, and 1618. As indicated previously, display 1606 is preferably an LCD display and a set of display control buttons 1604 may be used to scroll text up or down on the display 1606. The message "will you be home for dinner?" is shown on display 1606.

The set of six reply buttons 1608, 1610, 1612, 1614, 1616, and 1618 provide a flexible system for user generated replies to received messages. The display and storage logic 1508 provides information immediately above each button indicating a possible reply message by the user. In the simple example shown in FIG. 16, the user may reply "yes," "no," or "?" to the message 620 displayed on the screen 1606. The transmit logic 1518 generates an appropriate signal based upon which button the user presses. In this simple scenario, buttons 1614, 1616, and 1618 are unused.

In alternate applications, up to six possible reply messages may be shown on the screen 1606. Of course, other particularized applications may be envisioned for the reply feature of the mobile transceiver 1500. For example, if the user is a stockbroker, the display 1606 could display the terms "buy," "sell," or "hold" above the appropriate buttons. A variety of other applications may be envisioned.

With the six button reply option provided by mobile transceiver 1500, a three bit message may be transmitted by the mobile transceiver to the base receivers. The two remaining states of the three bit message may be used by the transmit logic 1518 for the autonomous acknowledgment signal which indicates that the message has been properly received, and for the autonomous negative acknowledgment signal which indicates that the message has not been completely or properly received.

Of course, the mobile transceiver 1500 shown in FIG. 16 could be configured differently to provide more or less reply buttons, different display control buttons, and different display formats as desired or needed by the user.

Further, the mobile transceiver 1500 could additionally include a data output port (not shown) for connection to

other electronic devices of the user. For example, the mobile transceiver could be connected through an output port to a laptop or palmtop PC, or could be incorporated therein. The PC could display the message on its screen, thereby obviating the need for the display 1606, and the keyboard could be used to generate any appropriate reply messages from the user, thereby obviating need for the reply buttons and allowing free form messages to be sent by the mobile transceiver. A user selected reply would be transferred to the mobile transceiver 1500 from the PC for transmission to the base receiver.

Alternatively, the mobile transceiver could be connected to a voice data replay device, such as a speaker, thereby allowing the user to receive messages from a voice mailbox, for example. Of course, a voice data generation device, such as a microphone, could be connected to the mobile transceiver 1500 to allow the user to reply to the voice mail message he has received or to initiate voice data communication from the mobile transceiver to the base receivers. Similarly, facsimile transmissions could be supported.

An alternate embodiment of the mobile unit includes only receive capabilities, but does not include any transmit capabilities. FIG. 17 shows a mobile receiver 1700. The various components of the mobile receiver generally correspond in functionality to the similar elements shown in FIG. 15. Of course, the mobile receiver 1700 cannot generate replies, which includes user initiated replies, an autonomous acknowledgment signals or negative acknowledgment signals, because of the lack of transmit capability. Also, the location of this alternate embodiment cannot be tracked by the network control center because of the lack of transmit capability. Generally, because of these reasons, the mobile receiver 1700 embodiment of the mobile unit is less preferable than the mobile transceiver embodiment 1500. Further, it should be appreciated that the mobile transceiver embodiment may include circuitry for generating various autonomous responses without interaction with the user.

F. The Base Receiver

The base receivers of the present system receive the low power output signal from the mobile transceiver unit. As is shown in FIG. 6, mobile receivers are dispersed throughout the geographic service area. Base receivers need not be associated with zonal boundaries per se, but will always be located to service at least one zone, of course. A few base receivers may exist in the overlap region between zones.

During transmission of the return signal by the mobile transceiver unit, it is possible that several base receivers could receive this return signal. In this instance, the network operations center 600 preferably selects the data from the base receiver with the highest received signal strength (i.e. the signal with the lowest probability of errors) to maximize the likelihood of receiving accurate data. The signal strength approach is preferred and can be satisfactorily implemented if the base receiver locations are carefully selected to insure adequate signal strength reception from the mobile transceiver units and to minimize the overlap between base receiver coverage areas. Alternately, the network operations center 600 could use "voting" techniques by comparing each data set from the several base receivers to arrive at the most likely return signal data using conventional voting receiver technology.

FIG. 18(A) shows a first embodiment of an analog base receiver. Analog receiver 1802 is connected to an antenna 1800. The analog receiver 1802 simply receives the signal from the antenna 1800 and removes the modulated wave-

form from the carrier frequency and outputs this waveform in analog format to a regional demodulator 1804 via data path 1806. Data path 1806 is preferably a 4 KHz analog telephone channel.

The regional demodulator 1804 receives signals from several analog receivers included in several base receivers. Preferably, the regional demodulator 1804 is located in the regional station, such as regional station 650 shown in FIG. 6. The demodulated signal from the regional demodulator 1804 is then transferred to the regional processing circuitry 1808, and then onto the network operations center 600.

The analog receiver 1802 could generate identification data to be transmitted with each received message so the network operations center 600 can determine the source of each message received. Alternatively, and preferably, dedicated communication paths are used for each base receiver and therefore, the source of the message can be inferred from the communication path that is activated.

FIG. 18(B) shows a digital base receiver embodiment which includes an antenna 1800 attached to an analog receiver 1802. As in the previously discussed embodiment, the analog receiver 1802 removes the modulated waveform from the carrier signal transmitted by the mobile transceiver unit. The analog receiver 1802 outputs the modulated waveform to a demodulator 1810 included in the base receiver. The demodulator 1810 produces a digital output signal corresponding to the data stream transmitted by the mobile transceiver unit. The demodulator 1810 provides the digital output signal to the regional processing circuitry 1808 in the regional station via data path 1812. Data path 1812 may be any conventional data path which can satisfactorily convey the digital data from the demodulator 1810 to the regional processing center 1808. The regional processing circuitry 1808 then passes the data to the network operations center 600.

FIG. 19 shows a digital base receiver including error correction and store and forward features. An antenna 1900 is connected to an analog receiver 1802 which is connected to a demodulator 1810, as previously described with reference to FIG. 18(B). The demodulated digital signal is output from demodulator 1810 to error correction circuitry 1906 which may perform error correction algorithms to insure the integrity of the return signal received from the mobile transceiver unit. Of course, the error correction circuitry should decode and correct data which have been compatibly encoded by the mobile transceiver.

The error corrected data output from the error correction circuitry 1906 is provided to a store and forward circuit 1908. The store and forward circuit 1908 stores the received data to allow it to be transmitted later at a convenient time and at a convenient data transmission rate.

For example, in the present system it is likely that the return signal traffic received by the base receiver will occur in short bursts at a relatively high data transfer rate. However, it is also likely that the average data transfer rate from the base receivers is substantially lower than the instantaneous data transfer rate during traffic bursts. The store and forward circuit 1908 may preferably act as a buffer to allow the return signal data to be communicated from the store and forward circuit 1908 to the regional processing circuitry 1808 at a lower (and less expensive) data transfer rate. Store and forward circuit 1908 is, therefore, preferably connected to regional processing circuitry 1808 via data path 1910 which may include a low cost telephone line.

G. The Network Operations Center

1. Overview

The network operations center 600 is shown in schematic form in FIG. 20. The network operations center 600 includes

21

a base receiver input system 2000 which receives data from the various regional stations throughout the system (e.g., regional stations 644 and 650) via various data paths, such as data paths 656 and 658 as shown in FIG. 6. The data received by the base receiver input system 2000 includes reply data from users with various control data. Base receiver input system 2000 may include appropriate conventional signal processing equipment. Control data may include data identifying the base receiver (i.e. location of the mobile unit) which received the associated reply. Preferably, the base receiver input section 2000 receives data from the regional stations via phone lines. However, other appropriate data paths may be considered.

The base receiver input system 2000 then provides the received data to a central computer 2002. The central computer 2002 may also receive input from a user input system 2004. For example, the user input system 2004 may receive data from users via phone lines who may access and interact with the central computer via voice, DTMF, or modem transmission and may include appropriate conventional signal processing equipment. A user may interact with the central computer 2002 to modify his service, to initiate or receive messages, or to perform other desirable functions.

Generally, the central computer 2002 processes the data received from the base receiver input system 2000 and from the user input system 2004 to perform various operations on the data, to update various database entries for use by the central computer 2002, and to generate data for transmission to a satellite uplink output system 2006.

It should be understood that, although FIG. 20 shows the central computer as existing at a single location in the network operations center 600, a distributed computing system may be used to perform the necessary functionality of the central computer 2002. Presently, however, a single location for the central computer 2002 is preferred.

Satellite uplink output system 2006 receives data from the central computer 2002 and provides it to satellite 606, shown in FIG. 5, for transmission to base transmitters within the system (e.g., base transmitters 612 and 614 in FIG. 6).

The central computer 2002 is also connected to a database system 2008 which stores various data such as message data, user status data, system status data, and message status data, for example, for use by the central computer 2002 in processing.

Also, a control access 2010 is provided to allow systems engineers or programmers to access the central computer 2002 to observe and modify its operations and system performance.

2. Database Structure

The database 2008 of the network operations center includes several database structures necessary for the operation of the system. While a preferred partitioning of these databases is described below, it should be understood that other partitionings could be considered, such as moving the various "user traffic" fields from the traffic statistics database to the user database.

a. The User Database

For example, the user database structure shown in FIG. 21 includes a record for each user of the system who possesses a mobile unit. The record for user 1 2100 includes various fields, such as an ID number field 2102 which indicates a unique number associated with that particular user. The transmit capability field 2106 indicates whether the mobile

22

unit assigned to the user has the capability to transmit. The last location field 2104 includes data which indicates the last known location of the user. The last location field may be updated when the central computer recognizes that a new base receiver has received a return signal from the mobile unit, thereby indicating the mobile unit has moved since the last return signal. Of course, if the mobile unit only includes a mobile receiver without transmit capability, the last location field 2104 cannot be updated and the mobile unit may be given a default location.

The service area field 2108 includes data corresponding to the area in which the user has subscribed to. For example, if a user desires service in geographic areas less than the total system service area, the central computer could use the data in the service area field 2108 to cause only selected base transmitters to attempt to transmit messages to a mobile unit.

The button format field 2110 includes data indicating the format of reply buttons the user may access on the mobile transceiver. Of course, for mobile units with only receive capabilities, the button format field will not be used.

The message field 2112 includes data representing one or more messages which are intended for the user. A receive flag is set when the central computer has received data indicating that the message has been received by the mobile unit via an acknowledgment signal. If the mobile unit does not have transmit capability, the receive flag is set upon transmission of the message by the appropriate base transmitters. The user database structure may include other fields for each user of the communication system of the present invention as needed to provide various desired services.

b. The Receiver Database

Database 2008 of FIG. 20 includes a receiver database (not shown) which includes an entry with several associated fields for each base receiver in the system. A first field for each base receiver preferably includes the total number of mobile units which have last communicated with this receiver. A second field for each base receiver preferably includes a list of base transmitters which may cover all or a portion of the receiver coverage area of that base receiver.

c. Traffic Statistics Database

Database 2008 of FIG. 20 should also include preferably a traffic statistics database as shown in FIG. 22 which includes various fields containing statistics calculated by the central computer 2002 concerning traffic patterns for the system. For example, the traffic database 2200 preferably includes a user field 2202 for data indicating a user of the network. Several fields are preferably associated with the user field 2202. Field 2204 includes data representing the number of probe signals sent by the network to locate the mobile unit associated with the user field 2202. Field 2206 includes data representing the number of registration signals received by the network from the mobile unit associated with the user field 2202. Field 2208 includes data representing the number of messages from the network that have been successfully delivered to the mobile unit associated with the user field 2202. Field 2210 may be used for other traffic related data, such as data indicating the average traffic per cycle, and data indicating a time average (i.e. for the last hour) traffic amount.

Further, the traffic database 2200 could include fields (not shown) for data concerning overall system performance and, in particular, each zone in the network. Such area specific traffic data may be useful in optimizing system performance by allowing intelligent redefinition of zonal boundaries.

23

d. The Service Queue

Database 2008 of FIG. 20 also includes a service queue 2300 as shown in FIG. 20. The service queue 2300 includes a current messages queue and a probe list queue. The current messages queue includes a system wide list of messages to be delivered by the system. The current messages queue includes, for example, a series of ID number fields 2302, 2304, and 2306 with associated data location fields 2308, 2310, and 2312, respectively. The data location fields 2308, 2310, and 2312 include pointers to the appropriate fields in the user database structure shown in FIG. 21. The ID number fields 2302, 2304, and 2306 include data indicating the ID number of the user to which the message is to be delivered.

In operation, the central computer retrieves the ID number 2302 and data location 2308 from the top of the current messages queue and retrieves the appropriate data from the user database 2100 to process and transmit a message to the user.

The probe list queue includes a ID number fields 2314, 2316, and 2318 and data location fields 2320, 2322, and 2324 similar in form to those in the current messages queue. The probe list queue contains a list of users which the system has previously attempted unsuccessfully to deliver a message to. In other words, the users listed in the probe list are considered to be "lost" by the system. The central computer 2002 then initiates a probe routine for the ID number 2314 and data location 2320 located at the top of the probe list.

After successful execution of the probe routine, the last location field 2304 in the user database structure 2100 will have been updated to provide an accurate last location of the user from the base receiver that received the mobile unit's acknowledgment to the probe signal. After the last location field 2304 has been updated, the message can then be replaced in the current messages queue for delivery to the user via the appropriate base transmitters located near the mobile unit.

Preferably, the network operations center gives priority to the delivery of all messages in the current message queue, and then sends probe signals to the users listed in the probe list queue after delivery has been attempted for all messages in the current message queue. If the message volume in the current message queue remains high for an extended period of time, the network operations center preferably begins to periodically send probe signals to the users listed in the Probe List, even though undelivered messages remain in the current messages queue. For example, in this instance of persistent filled current messages queue, the network operation center preferably transmits three probe signals in every cycle transmitted.

e. Base Transmitter Assignment List

The database 2008 of the network operations center also includes a base transmitter database 2400 as shown in FIG. 24. The base transmitter database 2400 includes a zonal assignment field 2404 for data representing a zone assignment associated with a base transmitter field 2402 in the system. Also, a field 2406 for data representing the base receivers in the transmitter coverage area, and a field 2408 for other data associated with a base transmitter, are associated with base transmitter field 2402. As can be seen in FIG. 24, each base transmitter in the network has a base transmitter field and associated fields as described above.

In normal operating conditions of the system with low amounts of message traffic being transmitted, each base transmitter will remain assigned to its particular zone.

24

However, the systems and methods of the present invention provide for dynamically changing the zonal assignments of various base transmitters to improve information throughput. These dynamic zone allocation concepts dynamically reassign base transmitters to new zones generally based upon the volume of messages transmitted during the systemwide time interval, and more particularly based upon the localized volume of messages to mobile units. In general, dynamic zone allocation may be used to deliver messages to mobile units in overlap areas (i.e. "zonal dithering"), or to balance the volume of message traffic between zones.

FIG. 25 is useful to explain these concepts. Various base transmitters, each designated as an "X," are dispersed throughout a region of space shown in FIG. 25. Also, various base receivers are dispersed throughout this region of space 2500, each being designated by an "R." The normal zonal boundary for zone 1 in FIG. 25 is shown by solid line 2502. A normal boundary for zone 2 is represented by solid line 2504 during normal load traffic operation conditions. As can be seen, base transmitters 2506, 2508, and 2510 are located near the zonal boundary of zone 2, and base transmitters 2512, 2514, and 2516 are located near the boundary of zone 1. Base receivers 2518 and 2520 are located in an overlap area 2521 between zones 1 and 2. As previously discussed, mobile units located in this overlap area 2521 near base receivers 2518 and 2520 must be communicated with during the systemwide time interval because of the interference created during the zonal time interval by adjacent base transmitters.

During normal, low to moderate volume system operations, the zonal overlap area 2521, i.e., interference area, near base receivers 2518 and 2520 will preferably have a small number of mobile units located therein. Therefore, communication with these mobile units will not significantly consume system resources by occasionally communicating with them during the systemwide time interval.

However, if the traffic volume from the overlap area 2521 near base receivers 2518 and 2520 increases, such as because additional mobile units enter this overlap area 2521, the handling of this traffic in the systemwide time interval can significantly consume system resources. For example, communication with a large number of mobile units during the systemwide time interval may significantly delay delivery of messages to units in this and other regions.

In this instance, the zonal boundaries are changed to remove this high traffic region from a zonal overlap area. For example, system efficiency is restored if the zone 1 boundary were moved to dashed line 2522 and the zone 2 boundary were moved to dashed line 2524.

The central computer 2002 may dynamically accomplish this zonal redefinition by assigning one or more base transmitters to a new zone to reduce systemwide time interval messages. In the present example shown in FIG. 25, the central computer updates the base transmitter zonal assignment list to reassign base transmitters 2512, 2514, and 2516 to zone 2 while removing these base transmitters from zone 1. In view of this zonal redefinition, the new zone 1 boundary is shown by dashed line 2522, and the new zone 2 boundary is shown by dashed line 2524. The high traffic region near base receivers 2518 and 2520 is now squarely within zone 2 and messages to these units may be efficiently delivered during subsequent zonal time interval(s).

In accordance with the invention, a preferred method 2600 for accomplishing zonal redefinition is shown in FIG. 26. In accordance with the method, step 2602 provides for transmitting substantially simultaneously a first information

25

signal and a second information signal, the first information signal being transmitted in simulcast by a first set of base transmitters assigned to a first zone, and the second information signal being transmitted in simulcast by a second set of base transmitters assigned to a second zone. For example, as shown in FIG. 25, the base transmitters in zone 1 defined by boundary line 2502 could be the first set of base transmitters, and the base transmitters located in zone 2 defined by boundary line 2504 could be the second set of base transmitters.

Step 2604 of the method provides for dynamically reassigning one or more of the base transmitters in the first set of base transmitters assigned to the first zone to the second set of base transmitters assigned to the second zone, thereby creating an updated first set of base transmitters and an updated second set of base transmitters. For example, base transmitters 2512, 2514, and 2516 could be reassigned from zone 1 to zone 2. As shown in FIG. 25, new zonal boundaries would be defined by dashed lines 2512 for zone 1 and 2524 for zone 2.

Step 2606 provides transmitting substantially simultaneously a third information signal and a fourth information signal, the third information signal being transmitted in simulcast by the updated first set of base transmitters and the fourth information signal being transmitted in simulcast by the updated second set of base transmitters. For example, as shown in FIG. 25, the base transmitters assigned to zone 1 defined by dashed line 2522 (i.e. not including base transmitters 2512, 2514, and 2516) could transmit during a subsequent communication cycle a third information signal, and base transmitters in zone 2 defined by dashed line 2524 (i.e. including base transmitters 2512, 2514, and 2516) could transmit a fourth information signal during that same subsequent communication cycle.

Further, it is desirable that during the redefinition of the zonal boundaries, it is insured that the new overlap area 2525 near base receiver 2526 and between dashed lines 2522 and 2524 is an area that is not likely to produce, or is not currently producing a high volume of message traffic. Generally, zonal boundaries should be preferably redefined to maximize information throughput by minimizing the data that must be transferred during the systemwide time interval. A network manager could review the overall traffic patterns and tendencies to determine an optimum redefinition of zonal boundaries. Of course, the central computer 2002 could also implement an algorithm accessing the traffic statistics database 2200 to determine optimal zonal boundary redefinition.

In a preferred embodiment in the instance where an entire region is saturated with mobile units, such as a large metropolitan area repetitive reassignments of base transmitters may be used to reduce message traffics during the systemwide time interval. There may exist no appropriate overlap area, such as overlap area 2525, with a low traffic level to facilitate a long term reassignment of base transmitters with the resulting redefinition of zonal boundaries. In this case, the preferred embodiment alternates between a first and second set of zonal boundaries over each communication cycle and does not attempt to deliver messages during the systemwide time interval.

For example, in FIG. 25 this preferred embodiment would utilize the zonal boundaries defined by lines 2502 and 2504 during a first zonal time interval and would not attempt to deliver messages to mobile units in overlap area 2521. In a subsequent cycle, this preferred embodiment redefines the zonal boundaries to dashed lines 2522 and 2524 and delivers

26

messages to the mobile units in previous overlap area 2521 during the zonal time interval using zone 2 base transmitters. During this cycle, the network would not attempt to deliver messages to mobile units in overlap area 2525. In yet a later cycle, this preferred embodiment would switch back to zonal boundaries 2502 and 2504 which would allow message delivery to mobile units in the now previous overlap area 2525 during the zonal time interval using zone 1 base transmitters. As can be seen, alternating between a first and second set of zonal boundaries advantageously reduces the need for communication during the systemwide time interval, but slows message delivery somewhat by only allowing communication to mobile units in overlap areas during zonal time intervals on alternating communication cycles.

H. The Preferred System Communication Protocol

The system communication protocol is preferably a time division protocol organized within repetitive communication cycles of preferably 30 seconds in duration.

The blocks of data transmitted by the network are preferably formed by a bit interleaving process to prevent loss of data during bursts of interference. Bit interleaving may be envisioned as stacking two or more blocks of data (which read from left to right), and then transmitting a bit stream in a column-by-column, top-to-bottom sequence. As can be seen, a burst of interference will likely only cause the loss of a few bits per word at most, which can be corrected by error correction techniques, rather than the loss of entire words. Of course, the mobile unit must appropriately deinterleave the data prior to processing.

FIG. 27 generally illustrates a variety of preferred time intervals which may variously be used for communication between the system and various sets and subsets of mobile units. An adaptable schedule for these time intervals is preferably generated, and may be revised according to system demands. The scheduling of the time intervals advantageously allows a mobile unit to "power down" during inactive time periods when the mobile unit will not transmit or receive any messages, thereby conserving battery power. Similarly, messages or information for delivery to a subset of the total number of mobile units will preferably be transmitted during time intervals which minimize the delivery of those messages or information to unintended mobile units not included in the subset to further conserve battery power.

A preferred cycle protocol 2700 is shown in FIG. 27(A). The cycle protocol 2700 includes a cycle header time interval 2702, a systemwide forward (FWD) batch time interval 2704, a systemwide response time interval 2706, a zonal forward (FWD) batch time interval 2708, a zonal reverse time interval 2710, and a reverse contention time interval 2712. Other arrangements, such as moving the systemwide reverse interval next to the zonal reverse interval may be considered if transmitter turn on time is significant.

The cycle protocol generally schedules time slots for systemwide and zonal forward channel information transfer from the network to the mobile units and for systemwide and zonal reverse channel information transfer from the mobile transceiver units to the network. Briefly, the cycle header 2702 field includes overhead or "housekeeping" information, the systemwide forward batch field 2704 and the zonal forward batch field 2708 provide forward communication capability through the base transmitters to the mobile units in a systemwide time interval and a zonal time

interval, respectively. The systemwide response field 2706 and zonal reverse field 2710 provide a return signal period for the mobile transceivers to respond to messages generated during the systemwide and zonal forward batch periods 2504 and 2508, respectively. Finally, the reverse contention 2712 field allows the mobile transceiver to initiate access to the network.

Each of the fields shown, except the cycle header 2702 field, is preferably variable in duration, and may be changed by the central computer 2002, depending on message traffic requirements. The beginning of the cycle is synchronized by the central computer to a time standard and preferably coincides with the start of minute or half minute intervals. Each mobile unit preferably includes timing circuitry, as previously described, which allows for the mobile unit to power up at the beginning of each cycle to receive communication.

For each cycle, the central computer 2002 calculates the amount of time required for each field to maximize information throughput by the network. For example, for the cycle protocol 2700 shown in FIG. 27(A), the central computer will calculate the amount of time necessary for the systemwide forward batch field 2704, the systemwide response interval 2706, the zonal forward interval 2708, the zonal reverse interval 2710, and the reverse contention interval 2712. The cycle header 2702 will preferably include timing offset data which will indicate the timing offset from the cycle header until the beginning of the systemwide response interval 2706, the beginning of the zonal forward interval 2708, the beginning of the zonal reverse interval 2710, and the beginning of the reverse contention interval 2712.

The cycle header 2702 starts preferably with an 8 digit long preamble (not shown) for digit synchronization purposes. The preamble allows for the mobile unit to synchronize its timing circuitry with the network. For example, the timing circuitry of the mobile unit could become offset from the network due to commonly caused inaccuracies. The preamble is followed by a "start of header" string of four digits and all timing offsets within the cycle are calculated as a number of predefined intervals beginning from the start of the last header digit. The start of header string is followed by an 8 digit string grouped into two words, each of which is protected against errors by encoding it using a forward error correcting code, preferably a Bose, Chaudhuri, and Hocquenghem (BCH) code or a Reed Solomon code. These error correcting codes add additional digits to the information digits in a code word, where the additional digits are a specific function of the information digits, so that if certain common error events occur, a decoding step involving all of the transmitted digits, both information and additional, can recover the original information digits. The first code word will contain a count of the current cycles executed for that day. The second code word will contain the necessary timing offsets for the beginning of the time intervals in the cycle protocol 2700. Further information regarding error correcting codes may be found in Gallagher, "Information Theory and Reliable Communication," Wiley 1968, which is hereby incorporated by reference.

The systemwide forward batch 2704 field generally includes a zonal header time interval including overhead information and a series of 64 batches. Also, the zonal forward interval 2710 similarly includes a zonal header time interval with overhead information and a series of 64 batches. Each batch is a string of data containing information specifically directed to a single group of mobile units. Each batch preferably contains information directed to a

certain class of mobile units with the classes divided by the types of service provided. For example, a first batch could be directed to all mobile transceiver units, and a second batch could be directed to all mobile receiver units. Further, each batch may contain several messages, each intended for different mobile units within the particular class of unit to which that batch is directed. Generally, FIG. 27(B) shows the forward batch interval protocol 2750 preferred for both the systemwide forward interval 2704 and the zonal forward interval 2708.

The systemwide forward interval 2704 is preferably used only for sending a probe signal to a mobile transceiver unit which does not respond to zonal messages (i.e. a "lost" unit). However, when necessary, the systemwide forward interval 2704 may be used to deliver messages to mobile units located in overlap areas. The ID number, or address, of the lost mobile unit is preferably followed by data indicating a timing offset which is a time delay amount until the beginning of the time slot designated for the return signal of that mobile unit. An alternative implementation, which may be useful for mobile units that have not responded for a period of time, could have mobile units that have received a probe signal respond during the reverse contention interval.

After the end of the broadcast on the systemwide forward batch time interval 2704, all network base transmitters shut down until the beginning of the zonal forward batch time interval 2708.

The forward batch interval protocol 2750 includes a forward channel header interval 2714 which includes data to allow the timing circuitry of the mobile units to synchronize themselves with the incoming data stream. The forward channel header 2714 also preferably includes data indicating a timing offset scheduling a reverse channel time interval for each batch, as may be required. Of course, the forward channel header 2714 for the systemwide forward interval 2704 would indicate a timing offset for reverse channel transmission during the systemwide response interval 2706, and the forward channel header 2714 for the zonal forward interval 2708 would indicate a timing offset for reverse channel transmission during the zonal reverse interval 2710.

The forward channel header 2714 further includes a data stream to the mobile unit listing which of the 64 batches will follow and the timing offsets indicating when those batches will be transmitted. Again, this feature advantageously allows the mobile unit to "power down" during the systemwide and zonal forward intervals 2704 and 2708 until the appropriate time for receiving its batch information, thereby conserving the battery power of the mobile unit. The remaining fields batch i 2720, batch j 2722, and batch k 2724 are the individual batches directed to the mobile units.

It should be understood that different classes of mobile units can follow different desirable batch protocols, depending on the type of service, processing power, battery capacity, or other factors.

The individual batch protocol 2780 is shown in FIG. 27(C). The batch header field 2726 is similar to the header fields discussed above for FIGS. 27(A) and (B). The batch header 2726 includes a list of particular mobile units to receive messages within the batch and includes timing offsets indicating when such messages will be broadcast. Further, the batch header 2726 includes data indicating a timing offset scheduling a reverse channel interval in the system reverse interval, the zonal reverse interval, or the reverse contention interval, as appropriate. Again, this information allows the mobile unit to extend its battery life because the mobile unit need only power up at the appro-

appropriate time to receive or transmit the appropriate message. Further, it is preferred that the reverse channel timing offset data be transmitted using error correction codes to insure accurate receipt thereof by the mobile unit. Accurate receipt of the reverse channel timing offset data will prevent unwanted or untimely transmissions by the mobile unit and insure that a mobile unit may properly transmit a negative acknowledgment signal if it fails to properly receive an unencoded message.

The individual message interval 2732 includes the individual message intended for a particular mobile unit or units. The duration of each message and number of messages within a batch may be varied by the network operations center 600 and is traffic dependent.

Each mobile unit with transmit capability that has received a message in the immediately previous systemwide forward interval 2704 or the zonal forward interval 2708 will have an appropriate time slot for transmission scheduled in the systemwide response interval 2706, or the zonal reverse interval 2710, respectively. The timing circuit in the mobile transceiver unit determines the assigned time slot for transmission. For example, if the mobile unit simply intends to transmit an acknowledgment signal, which indicates that the mobile unit has properly received the message from the network, an 8 bit preamble followed by the address of that mobile unit need only be transmitted and a 3 bit acknowledgment. However, if a more extensive reply from the mobile unit is required, additional data could be transferred during this time slot. In particular, long reverse messages could be scheduled in response to a request from the mobile unit sent during the contention interval 2712, as discussed hereinafter.

Due to the low power transmit capability of the mobile transceiver units, there is an increased likelihood of data transmission errors for reply signals. The extended Golay code for error protection may be utilized for reverse channel messages from mobile transceiver units to the network.

The systemwide response interval 2706 and the zonal reverse interval 2710 provide communication capability from the mobile transceiver units to the network (i.e. the reverse channel).

Still further, a preferred embodiment accommodates mobile terminals with extensive reverse message generation capabilities (e.g., a laptop computer connected to a radio transceiver) by allowing for contention messages that request extended reverse channel time for the transmission of a long reverse message. The reverse contention interval 2712 is located after the zonal reverse interval 2710 and provides for unscheduled messages from the mobile unit to the network. For example, the mobile transceiver unit could send a message to the network during the reverse contention interval 2712 indicating that the user no longer wishes to receive messages, thereby terminating service. Also, the user could transmit a message to the network during the reverse contention interval 2712 indicating that the user now desires to reestablish services and begin receiving messages from the network. Further, a "registration signal," which is discussed infra, could be transmitted during the reverse contention interval 2712.

The reverse contention interval preferably utilizes a so-called "slotted ALOHA" protocol, which allows the mobile unit to randomly select a predefined time slot within the contention interval to transmit a message. A mobile station wanting to transmit will first divide the contention interval into slots, preferably 5.33 ms in length, and then choose randomly any of them to start transmitting. The

slotted ALOHA protocol is preferred because of the low likelihood of data "collisions" (i.e. 2 or more mobile units transmitting during the same time slot).

I. Registration of the Mobile Unit

Because the network operations center 600 stores the location of each mobile unit in the system in the user database 2100, it is preferred that each mobile transceiver unit have the capability to "register" with the network operations center 600 by sending a registration signal to a base receiver into the network to update the location data.

The mobile transceiver unit preferably registers by simply transmitting its identification number to a base receiver, which forwards this data and data representing the location of the base receiver to the network operations center 600.

The mobile transceiver preferably registers upon crossing zonal boundaries to alert the network operation center that the mobile transceiver has left one zone and entered another. For example, the mobile unit could receive information from the nearest base transmitter identifying which zone that base transmitter is assigned to at the beginning of each communication cycle. Upon receipt of such information from a base transmitter indicating that a nearby base transmitter is assigned to a new zone, the mobile transceiver then preferably transmits a registration signal.

The mobile transceiver unit may also transmit a registration signal in other desirable instances. For example, if the mobile transceiver unit has moved away from the transmitter coverage areas of the network for a period of time, the mobile transceiver unit may preferably transmit a registration signal upon returning to a coverage area. The display and storage logic 1508 of the mobile transceiver unit preferably recognizes that the unit has left the coverage area of the network upon failure to receive data from a base transmitter in the network during the cycle header time interval 2702, for example. The mobile unit may leave the coverage area of a base transmitter of the network when the user takes the unit out of the country, or enters the basement of a building, for example.

The mobile unit may also preferably transmit a registration signal when power is restored to the mobile unit after having power removed, such as after being turned off by the user. Of course, the power may be restored to the unit by replacing or recharging a dead battery, which may also cause transmission of a registration signal.

In general, the network must balance the need for frequent registrations by the mobile transceiver units, and the desirable result of accurately knowing the location of each mobile unit, thereby preventing the need for probe signals, with the undesirable overhead costs of too frequent registration, which sacrifices data throughput by utilizing valuable transmit time.

In the preferred embodiment, the central computer 2002 of the network operations center 600 can achieve desirable performance by implementing one or more algorithms to evaluate the need for registration by a mobile unit, and then appropriately controlling the registration performance of that mobile unit. If the central computer determines that registration of a particular mobile unit is useful, then the mobile unit preferably should receive a message from the network to cause the mobile unit to send registration signals at appropriate times. Conversely, if the central computer determines that the registration signals from the mobile unit are too frequently not useful, the mobile unit preferably should receive a message from the network to cause the mobile unit not to transmit registration signals.

To implement this feature, the mobile transceiver unit further preferably includes a registration flag (not shown) in the display and storage logic section 1508. If the registration flag is set, the display and storage logic section 1508 causes the mobile transceiver to autonomously send a registration signal to the network operations center on a desired basis. If the registration flag is not set, the display and storage logic section 1508 prevents any registration signals from being sent.

The registration flag may be set or removed upon command from the network operations center by transmission of an appropriate signal from a base transmitter near the mobile unit. A variety of algorithms, possibly regarding individual users or groups of users, can be used to determine whether or not the registration flag should be set. It should be appreciated that the present invention provides two distinct algorithms for implementing these registration concepts depending upon whether the registration flag is set or not in the mobile unit (i.e. the state of the mobile unit).

FIG. 28(A) shows a flow chart describing a preferred method 2800 for implementing the registration concepts of the present invention wherein the registration feature of the mobile unit is disabled. In step 2802, the network sends a message to disable the registration feature (i.e. set the registration flag to zero) of the mobile unit to disable the mobile transceiver's capability to transmit a registration signal. As can be seen, step 2802 determines the initial state for the method set forth in FIG. 28(A).

In step 2804, the network stores the number of probe signals sent to the mobile transceiver during a first period of time, and the number of messages successfully delivered to the mobile transceiver by the network during a second period of time. Preferably, the first and second time intervals are identical. The traffic statistics database 2200 of the database 2008 is preferably used to store the number of probe signals and successful messages for each mobile unit. As explained hereinafter, these two statistics from the operation of the network are preferably used to determine whether registration by the mobile unit is useful.

In step 2806, the stored number of probe signals and number of messages successfully delivered is processed to evaluate a likelihood that a probe signal will be required to be set by the network to locate the mobile unit to deliver a message. The preferred embodiment of the invention processes the stored number of probe signals and messages successfully delivered in accordance with the method set forth in FIG. 29(A).

To Referring now to FIG. 29(A), therein is shown a series of substeps which are preferably performed during the implementation of the processing step 2804 shown in FIG. 28(A). In particular, steps 2902 and 2904 are event driven and only proceed to the next step after an input has been received by the network. Step 2902 determines if the network sent a probe signal to a lost mobile transceiver unit and if a reply to the probe signal was received by a base receiver in the network. If this event occurs, a counter (not shown) is incremented by a value P by the central computer 2002.

In step 2904, if a message was successfully delivered to a mobile transceiver, preferably including an acknowledgment signal return from the mobile transceiver to the network, the counter (not shown) in the central computer 2002 is decremented by a value D.

After the occurrence of either of the events tested for in step 2902 or step 2904, the algorithm proceeds to step 2906. In step 2906, if the counter value is greater than a predetermined value J, this indicates that the likelihood that a

probe signal will be necessary to locate the mobile transceiver is greater than a selected value.

As can be seen, the process of substeps in FIG. 29(A) balances the frequency of probe signals sent to a particular unit against the number of successfully delivered messages to that unit. If the system must send a large number of probe signals, it would be useful to enable the registration feature by setting the registration flag on that mobile unit to enable the registration feature. In contrast, if many messages have been successfully delivered without requiring a probe signal, it is unnecessary to enable the registration feature by setting the registration flag.

In step 2808, a message is sent to the mobile unit to enable the mobile transceiver's capability to transmit a registration signal if the calculated likelihood in step 2804 exceeds a selected value. As can be seen, step 2808 preferably sets the registration flag in the mobile transceiver unit.

FIG. 28(B) shows a flow chart describing a method 2810 for implementing the registration concepts of the present invention wherein the registration feature of the mobile unit is enabled.

In step 2812, the network sends a message to enable the registration feature (i.e. set the registration flag to 1) of the mobile unit to enable the mobile transceiver's capability to transmit a registration signal. As can be seen, step 2812 determines the initial state for the method set forth in FIG. 28(B).

In step 2814, the network stores the number of registration signals received by the network during a first period of time, and the number of messages successfully delivered to the mobile transceiver by the network during a second period of time. Preferably, the first and second time intervals are identical. The traffic statistics database 2200 of the database 2008 is preferably used to store the number of registration signals and successful messages for each mobile unit. As explained Thereinafter, these two statistics from the operation of the network are preferably used to determine whether the registration by the mobile unit is useful.

In step 2816, the stored number of registration signals and number of messages successfully delivered is processed to evaluate the likelihood that a registration signal will be received by a base receiver in the network that will not be used by the network to determine a set of base transmitters to be operated to transmit a message to the mobile transceiver. The preferred embodiment of the invention processes the stored number of registration signals received and number of messages successfully delivered in accordance with the method set forth in FIG. 29(B).

Referring now to FIG. 29(B), therein is shown a series of substeps which are preferably performed during the implementation of the processing step 2814 shown in FIG. 28(B). In particular, steps 2912 and 2914 are event driven and only proceed to the next step after an input has been received by the network. Step 2912 determines if a registration signal was received by a base receiver in the network. If so, a counter (not shown) in the central computer 2002 is incremented by a value A. In step 2914, if a message was successfully delivered to a mobile transceiver, preferably including an acknowledgment signal return from the mobile transceiver to the system, the counter (not shown) in the central computer 2002 is decremented by a value M.

It should be understood that the counter referred to with regard to steps 2912 and 2914 is different than the counter referred to with regard to steps 2902 and 2904 since each counter only necessary when the registration feature is enabled or disabled in the mobile transceiver. However, the same physical or logical device may be used to implement both counters.

After the occurrence of either events in the step 2912 or step 2914, the algorithm proceeds to step 2916. In step 2916, the process determines if the counter value is greater than a predetermined value T. The value of T can be varied to meet the needs of a particular network. When the counter value exceeds T, it is indicated that the likelihood that a registration signal from that mobile unit will not be used by the network to determine a new set of base transmitters, and therefore the registration status for that mobile unit needs to be changed to disable the registration feature.

In other words, the process in FIG. 29(B) balances the frequency of registration signals sent by a particular unit against the number of successfully delivered messages to that unit. As can be seen, if the mobile unit sends a large number of registration signals without the system using these registration signals, it would be useful to have the registration feature on that mobile unit disabled. In contrast, if many messages have been successfully delivered without too many registration signals being sent by the mobile unit, it is unnecessary for the registration feature to be disabled.

In step 2818, a message is sent to the mobile unit to disable the mobile transceiver's capability to transmit a registration signal if the calculated likelihood in step 2814 exceeds a selected value. As can be seen, step 2818 may preferably remove the registration flag in the mobile transceiver unit.

Of course, it should be understood that the variables P, D, and J used in FIG. 29(A), and the variables A, M, and T used in FIG. 29(B) can be adjusted as desired to enhance system performance, as will be apparent to one of ordinary skill in the art. The counters can be implemented with so-called "reflective boundaries" so that if a counter reaches a minimum value (e.g., zero), it will continuously reset to that minimum value when further decremented.

It will be apparent to those skilled in the art that various modifications and variations can be made in the systems and methods of the present invention without departing from the scope or spirit of the invention.

Other embodiments of the invention will be apparent to those skilled in the art from consideration of the specification and practice of the invention disclosed herein. It is intended that the specification and examples be considered as exemplary only, with a true scope and spirit of the invention being indicated by the following claims.

What is claimed is:

1. A multi-carrier simulcast transmission system for transmitting in a desired frequency band at least one message contained in an information signal, the system comprising:

a first transmitter configured to transmit a first plurality of carrier signals within the desired frequency band, each of the first plurality of carrier signals representing a portion of the information signal substantially not represented by others of the first plurality of carrier signals; and

a second transmitter, spatially separated from the first transmitter, configured to transmit a second plurality of carrier signals in simulcast with the first plurality of carrier signals, each of the second plurality of carrier signals corresponding to and representing substantially the same information as a respective carrier signal of the first plurality of carrier signals.

2. The multi-carrier simulcast transmission system of claim 1, wherein the first transmitter comprises a plurality of transmitters located in a first area, and the second transmitter comprises a plurality of transmitters located in a second area.

3. The multi-carrier simulcast transmission system of claim 1, wherein the first and second pluralities of carrier signals are evenly spaced within the desired frequency band.

4. The multi-carrier simulcast transmission system of claim 3, wherein the first and second pluralities of carrier signals are spaced approximately every 3 KHz, and wherein the desired frequency band is approximately 50 KHz wide.

5. The multi-carrier simulcast transmission system of claim 1, wherein each of the first and second pluralities of carrier signals comprise eight carrier signals.

6. The multi-carrier simulcast transmission system of claim 1, wherein the first and second pluralities of carrier signals include an identical number of carrier signals, and wherein each carrier signal in the first plurality corresponds to and is slightly frequency shifted 10-20 Hz from the respective carrier signal in the second plurality.

7. The multi-carrier simulcast transmission system of claim 1, wherein the first transmitter comprises means for modulating the first plurality of carrier signals using a modulation scheme, and the second transmitter comprises means for modulating the second plurality of carrier signals using the modulation scheme.

8. The multi-carrier simulcast transmission system of claim 7, wherein the modulation scheme is selected from the group including: modulated on/off keying, binary frequency shift keying, M'ary frequency shift keying, and quadrature amplitude modulation.

9. The multi-carrier simulcast transmission system of claim 2, further comprising:

a network operations center configured to generate the information signal, the network operations center including a receiver for receiving data input to the network operations center, a database for storing data, a central computer connected to the receiver and the database for processing the input data and the database data to generate the information signal, and a satellite uplink connected to the central computer for broadcasting the information signal; and

a satellite for receiving the information signal from the network operations center and for retransmitting the information signal to the first and second transmitters, wherein each of the first and second transmitters comprises satellite downlink means and base transmitter means.

10. In a multi-carrier simulcast transmission system, a method for transmitting in a desired frequency band [a] at least one message contained in an information signal, the method comprising the steps of:

generating a first plurality of carrier signals within the desired frequency band, each of the first plurality of carrier signals representing a portion of the information signal substantially not represented by others of the first plurality of carrier signals;

generating a second plurality of carrier signals within the desired frequency band, each of the second plurality of carrier signals corresponding to and representing substantially the same information as a respective carrier signal of the first plurality of carrier signals;

transmitting the first plurality of carrier signals from a first transmitter;

transmitting the second plurality of carrier signals from a second transmitter in simulcast with transmission of the first plurality of carrier signals from the first transmitter.

11. The method of claim 10, wherein the first and second pluralities of carrier signals are evenly spaced within the desired frequency band.

35

12. The method of claim 10, wherein the first and second pluralities of carrier signals are spaced approximately every 3 KHz, and wherein the desired frequency band is approximately 50 KHz wide.

13. The method of claim 10, wherein the first and second pluralities of carrier signals each comprise eight carrier signals.

14. The method of claim 10, wherein the first and second pluralities of carrier the first plurality corresponds to and is slightly frequency shifted 10-20 Hz from the respective carrier signal in the second plurality.

15. The method of claim 10, wherein at least one of the first and second pluralities of carrier signals is modulated according to a modulation scheme selected from the group including: modulated on/off keying, binary frequency shift keying, M'ary frequency shift keying, and quadrature amplitude modulation.

16. The method of claim 10, wherein the step of generating the first plurality of carrier signals comprises the substep of modulating the first plurality of carrier signals using a modulation scheme.

17. The method of claim 10, wherein the step of generating a second plurality of carrier signals comprises the substep of modulating the second plurality of carrier signals using a modulation scheme.

36

18. The method of claim 10, wherein the step of generating a second plurality of carrier signals comprises the substep of generating the second plurality of carrier signals at frequencies slightly offset from the first plurality of carrier signals.

19. A multi-carrier simulcast transmission system for transmitting in a desired frequency band at least one message contained in an information signal, the system comprising:

means for transmitting a first plurality of carrier signals within the desired frequency band, each of the first plurality of carrier signals representing a portion of the information signal substantially not represented by others of the first plurality of carrier signals; and

means for transmitting a second plurality of carrier signals in simulcast with the first plurality of carrier signals, each of the second plurality of carrier signals corresponding to and representing substantially the same information as a respective carrier signal of the first plurality of carrier signals.

* * * * *

UNITED STATES PATENT AND TRADEMARK OFFICE
CERTIFICATE OF CORRECTION

PATENT NO. : 5,915,210
DATED : June 22, 1999
INVENTOR(S) : CAMERON et al.

It is certified that error appears in the above-identified patent and that said Letters Patent is hereby corrected as shown below:

Claim 10, column 34, line 46, delete "[a]".

Claim 14, column 35, line 9, after "carrier" insert therefor --signals include an identical number of carrier signals, and wherein each carrier signal in--.

Signed and Sealed this
Twenty-third Day of November, 1999

Attest:

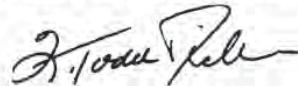

Attesting Officer

Q. TODD DICKINSON

Acting Commissioner of Patents and Trademarks

BAR CODE LABEL		U.S. PATENT APPLICATION			
					
SERIAL NUMBER	FILING DATE	CLASS	GROUP PART UNIT		
08/760,457	12/06/96 RULE 60	455	2611		
APPLICANT	DENNIS W. CAMERON, JACKSON, MS; WALTER C. ROEHR JR., RESTON, VA; JAI P. BHAGAT, JACKSON, MS; MASOOD GARAH, MADISON, MS; WILLIAM D. HAYS, JACKSON, MS; DAVID W. ACKERMAN, WASHINGTON, DC.				
	CONTINUING DATA*** VERIFIED THIS APPLN IS A CON OF 07/973,918 11/12/92 PAT 5,590,403				
	FOREIGN/PCT APPLICATIONS*** VERIFIED				
	FOREIGN FILING LICENSE GRANTED 02/12/97				
STATE OR COUNTRY	SHEETS DRAWING	TOTAL CLAIMS	INDEPENDENT CLAIMS	FILING FEE RECEIVED	ATTORNEY DOCKET NO.
MS	29	1	1	\$770.00	03680.0083-0
ADDRESS	FINNEGAN HENDERSON FARABOW GARRETT AND DUNNER 1300 I STREET NW WASHINGTON DC 20005-3315				
TITLE	METHOD AND SYSTEM FOR PROVIDING MULTICARRIER SIMULCAST TRANSMISSION				
This is to certify that annexed hereto is a true copy from the records of the United States Patent and Trademark Office of the application which is identified above. By authority of the COMMISSIONER OF PATENTS AND TRADEMARKS					
Date	Certifying Officer				

BAR CODE LABEL		U.S. PATENT APPLICATION			
					
SERIAL NUMBER	FILING DATE	CLASS	GROUP ART UNIT		
08/760,457	12/06/96 RULE 60	455	2611		
APPLICANT	DENNIS W. CAMERON, JACKSON, MS; WALTER C. ROEHR JR., RESTON, VA; JAI P. BHAGAT, JACKSON, MS; MASOOD GARABI, MADISON, MS; WILLIAM D. HAYS, JACKSON, MS; DAVID W. ACKERMAN, WASHINGTON, DC.				
	CONTINUING DATA*** VERIFIED THIS APPLN IS A CON OF 07/973,918 11/12/92 PAT 5,590,403				
	FOREIGN/PCT APPLICATIONS*** VERIFIED				
	FOREIGN FILING LICENSE GRANTED 02/12/97				
STATE OR COUNTRY	SHEETS DRAWING	TOTAL CLAIMS	INDEPENDENT CLAIMS	FILING FEE RECEIVED	ATTORNEY DOCKET NO.
MS	29	1	1	\$770.00	03680.0083-0
ADDRESS	FINNEGAN HENDERSON FARABOW GARRETT AND DUNNER 1300 I STREET NW WASHINGTON DC 20005-3315				
TITLE	METHOD AND SYSTEM FOR PROVIDING MULTICARRIER SIMULCAST TRANSMISSION				
This is to certify that annexed hereto is a true copy from the records of the United States Patent and Trademark Office of the application which is identified above. By authority of the COMMISSIONER OF PATENTS AND TRADEMARKS					
Date	Certifying Officer				

OS/MA/ME/TE

PATENT APPLICATION SERIAL NO. _____

U.S. DEPARTMENT OF COMMERCE
PATENT AND TRADEMARK OFFICE
FEE RECORD SHEET

300 SD 01/06/97 08760457
1 101 770.00 CK 036800083040

PTO-1556
(5/87)

Transaction History Date 1996-12-06
 Date information retrieved from USPTO Patent
 Application Information Retrieval (PAIR)
 system records at www.uspto.gov

35

790-101 A
 08/760457

#2/A
 JLR
 3/7/97



THE UNITED STATES PATENT AND TRADEMARK OFFICE
 ASSISTANT COMMISSIONER FOR PATENTS
 Washington, D.C. 20231

Attorney Docket No. 03680.0083-04000

Prior Application:
 Art Unit: 2611
 Examiner: T. Le

SIR: This is a request for filing a

Continuation under 37 C.F.R. § 1.60 of pending prior application Serial No. 07/973,918
 filed November 12, 1992 of Dennis Cameron et al. for A NATIONWIDE
COMMUNICATION SYSTEM.

1. Enclosed is a complete copy of the prior application including the oath or Declaration and drawings, if any, as originally filed. I hereby verify that the attached papers are a true copy of prior application Serial No. 07/973,918 as originally filed on November 12, 1992.
2. Cancel claims _____ (At least one original independent claim must be retained for filing purposes.)
3. A Preliminary Amendment is enclosed.
4. The filing fee is calculated on the basis of the claims existing in the prior application as amended at 2 and 3 above.

(1) For	(2) Number Filed	(3) Number Extra	(4) Rate	(5) Basic Fee \$770
Total Claims	.18-20=	0	x \$ 22.00	\$0
Independent Claims	2-3=	0	x \$ 78.00	\$0
Multiple Dependent Claim(s) (if applicable)			+\$250.00	\$0
Total =				\$770.00
Reduction by 1/2 for filing by small entity				-
TOTAL FILING FEE =				\$770.00

5. A check in the amount of \$770 to cover the filing fee is enclosed.

6. The Commissioner is hereby authorized to charge any fees which may be required including fees due under 37 C.F.R. § 1.1.6 and any other fees due under 37 C.F.R. § 1.17, or credit any overpayment during the pendency of this application to deposit Account No. 06-0916.

7. Amend the specification by inserting before the first line, the sentence:

A1

^A This is a continuation of application Serial No. 07/973,918, filed November 12, 1992, U.S. Pat. No. 5,590,403

8. New formal drawings are enclosed.

9. The prior application is assigned of record to: Destineer Corporation.

10. Priority of application Serial No. _____, filed on _____ in _____ (country) is claimed under 35 U.S.C. § 119.

11. A verified statement claiming small entity status is enclosed or is on file in the prior application.

12. The power of attorney in the prior application is to at least one of the following: FINNEGAN, HENDERSON, FARABOW, GARRETT & DUNNER, L.L.P., Reg. No. 22,540; Douglas B. Henderson, Reg. No. 20,291; Ford F. Farabow, Jr., Reg. No. 20,630; Arthur S. Garrett, Reg. No. 20,338; Donald R. Dunner, Reg. No. 19,073; Brian G. Brunsvold, Reg. No. 22,593; Tipton D. Jennings, IV, Reg. No. 20,645; Jerry D. Voight, Reg. No. 23,020; Laurence R. Hefter, Reg. No. 20,827; Kenneth E. Payne, Reg. No. 23,098; Herbert H. Mintz, Reg. No. 26,691; C. Larry O'Rourke, Reg. No. 26,014; Albert J. Santorelli, Reg. No. 22,610; Michael C. Elmer, Reg. No. 25,857; Richard H. Smith, Reg. No. 20,609; Stephen L. Peterson, Reg. No. 26,325; John M. Romary, Reg. No. 26,331; Bruce C. Zotter, Reg. No. 27,680; Dennis P. O'Reilly, Reg. No. 27,932; Allen M. Sokal, Reg. No. 26,695; Robert D. Bajefsky, Reg. No. 25,387; Richard L. Stroup, Reg. No. 28,478; David W. Hill, Reg. No. 28,220; Thomas L. Irving, Reg. No. 28,619; Charles E. Lipsey, Reg. No. 28,165; Thomas W. Winland, Reg. No. 27,605; Basil J. Lewis, Reg. No. 28,818; Martin I. Fuchs, Reg. No. 28,508; E. Robert Yoches, Reg. No. 30,120; Barry W. Graham, Reg. No. 29,924; Susan Haberman Griffen, Reg. No. 30,907; Richard B. Racine, Reg. No. 30,415; Thomas H. Jenkins, Reg. No. 30,857; Robert E. Converse, Jr., Reg. No. 27,432; Clair X. Mullen, Jr., Reg. No. 20,348; Christopher P. Foley, Reg. No. 31,354; John C. Paul, Reg. No. 30,413; Roger D. Taylor, Reg. No. 28,992; David M. Kelly, Reg. No. 30,953; Kenneth J. Meyers, Reg. No. 25,146; Carol P. Einaudi, Reg. No. 32,220; Walter Y. Boyd, Jr., Reg. No. 31,738; Steven M. Anzalone, Reg. No. 32,095; Jean B. Fordis, Reg. No. 32,984; Barbara C. McCurdy, Reg. No. 32,120; James K. Hammond,

Reg. No. 31,964; Richard V. Burgujian, Reg. No. 31,744; J. Michael Jakes, Reg. No. 32,824; and Allen M. Lo, Reg. No. 37,059.

13. The power appears in the original declaration of the prior application.
14. Since the power does not appear in the original declaration, a copy of the power in the prior application is enclosed.
15. Please address all correspondence to FINNEGAN, HENDERSON, FARABOW, GARRETT AND DUNNER, L.L.P., 1300 I Street, N.W., Washington, D.C. 20005-3315.
16. Recognize as associate attorney _____.
17. Also enclosed is a Petition Under 37 C.F.R. § 1.48(b).

PETITION FOR EXTENSION. If any extension of time is necessary for the filing of this application, including any extension in the parent application, serial no. 07/973,918 filed November 12, 1992, for the purpose of maintaining copendency between the parent application and this application, and such extension has not otherwise been requested, such as extension is hereby requested, and the Commissioner is authorized to charge necessary fees for such an extension to our Deposit Account No. 06-0916. A duplicate copy of this paper is enclosed for use in charging the deposit account.

FINNEGAN, HENDERSON, FARABOW,
GARRETT & DUNNER, L.L.P.

By: _____

Allen M. Lo
Allen M. Lo
Reg. No.: 37,059

Date: December 6, 1996

08/760457



IN THE UNITED STATES PATENT AND TRADEMARK OFFICE

ASSISTANT COMMISSIONER FOR PATENTS
Washington, D.C. 20231

Attorney Docket No. 03680.0083-04000

Prior Application:
Art Unit: 2611
Examiner: T. Le

SIR: This is a request for filing a

Continuation under 37 C.F.R. § 1.60 of pending prior application Serial No. 07/973,918 filed November 12, 1992 of Dennis Cameron et al. for A NATIONWIDE COMMUNICATION SYSTEM.

1. Enclosed is a complete copy of the prior application including the oath or Declaration and drawings, if any, as originally filed. I hereby verify that the attached papers are a true copy of prior application Serial No. 07/973,918 as originally filed on November 12, 1992.
2. Cancel claims _____ (At least one original independent claim must be retained for filing purposes.)
3. A Preliminary Amendment is enclosed.
4. The filing fee is calculated on the basis of the claims existing in the prior application as amended at 2 and 3 above.

(1) For	(2) Number Filed	(3) Number Extra	(4) Rate	(5) Basic Fee \$770
Total Claims	18-20=	0	x \$ 22.00	\$0
Independent Claims	2-3=	0	x \$ 78.00	\$0
Multiple Dependent Claim(s) (if applicable)			+\$250.00	\$0
Total =				\$770.00
Reduction by 1/2 for filing by small entity				-
TOTAL FILING FEE =				\$770.00

5. A check in the amount of \$770 to cover the filing fee is enclosed.

6. The Commissioner is hereby authorized to charge any fees which may be required including fees due under 37 C.F.R. § 1.1.6 and any other fees due under 37 C.F.R. § 1.17, or credit any overpayment during the pendency of this application to deposit Account No. 06-0916.
7. Amend the specification by inserting before the first line, the sentence:
 -- This is a continuation of application Serial No. 07/973,918, filed November 12, 1992.--
8. New formal drawings are enclosed.
9. The prior application is assigned of record to: Destineer Corporation.
10. Priority of application Serial No. _____, filed on _____ in _____ (country) is claimed under 35 U.S.C. § 119.
11. A verified statement claiming small entity status is enclosed or is on file in the prior application.
12. The power of attorney in the prior application is to at least one of the following: FINNEGAN, HENDERSON, FARABOW, GARRETT & DUNNER, L.L.P., Reg. No. 22,540; Douglas B. Henderson, Reg. No. 20,291; Ford F. Farabow, Jr., Reg. No. 20,630; Arthur S. Garrett, Reg. No. 20,338; Donald R. Dunner, Reg. No. 19,073; Brian G. Brunsvold, Reg. No. 22,593; Tipton D. Jennings, IV, Reg. No. 20,645; Jerry D. Voight, Reg. No. 23,020; Laurence R. Hefter, Reg. No. 20,827; Kenneth E. Payne, Reg. No. 23,098; Herbert H. Mintz, Reg. No. 26,691; C. Larry O'Rourke, Reg. No. 26,014; Albert J. Santorelli, Reg. No. 22,610; Michael C. Elmer, Reg. No. 25,857; Richard H. Smith, Reg. No. 20,609; Stephen L. Peterson, Reg. No. 26,325; John M. Romary, Reg. No. 26,331; Bruce C. Zotter, Reg. No. 27,680; Dennis P. O'Reilley, Reg. No. 27,932; Allen M. Sokal, Reg. No. 26,695; Robert D. Bajefsky, Reg. No. 25,387; Richard L. Stroup, Reg. No. 28,478; David W. Hill, Reg. No. 28,220; Thomas L. Irving, Reg. No. 28,619; Charles E. Lipsey, Reg. No. 28,165; Thomas W. Winland, Reg. No. 27,605; Basil J. Lewis, Reg. No. 28,818; Martin I. Fuchs, Reg. No. 28,508; E. Robert Yoches, Reg. No. 30,120; Barry W. Graham, Reg. No. 29,924; Susan Haberman Griffen, Reg. No. 30,907; Richard B. Racine, Reg. No. 30,415; Thomas H. Jenkins, Reg. No. 30,857; Robert E. Converse, Jr., Reg. No. 27,432; Clair X. Mullen, Jr., Reg. No. 20,348; Christopher P. Foley, Reg. No. 31,354; John C. Paul, Reg. No. 30,413; Roger D. Taylor, Reg. No. 28,992; David M. Kelly, Reg. No. 30,953; Kenneth J. Meyers, Reg. No. 25,146; Carol P. Einaudi, Reg. No. 32,220; Walter Y. Boyd, Jr., Reg. No. 31,738; Steven M. Anzalone, Reg. No. 32,095; Jean B. Fordis, Reg. No. 32,984; Barbara C. McCurdy, Reg. No. 32,120; James K. Hammond,

Reg. No. 31,964; Richard V. Burgujian, Reg. No. 31,744; J. Michael Jakes, Reg. No. 32,824; and Allen M. Lo, Reg. No. 37,059.

- 13. The power appears in the original declaration of the prior application.
- 14. Since the power does not appear in the original declaration, a copy of the power in the prior application is enclosed.
- 15. Please address all correspondence to FINNEGAN, HENDERSON, FARABOW, GARRETT AND DUNNER, L.L.P., 1300 I Street, N.W., Washington, D.C. 20005-3315.
- 16. Recognize as associate attorney _____
- 17. Also enclosed is a Petition Under 37 C.F.R. § 1.48(b).

PETITION FOR EXTENSION. If any extension of time is necessary for the filing of this application, including any extension in the parent application, serial no. 07/973,918 filed November 12, 1992, for the purpose of maintaining copendency between the parent application and this application, and such extension has not otherwise been requested, such as extension is hereby requested, and the Commissioner is authorized to charge necessary fees for such an extension to our Deposit Account No. 06-0916. A duplicate copy of this paper is enclosed for use in charging the deposit account.

FINNEGAN, HENDERSON, FARABOW,
GARRETT & DUNNER, L.L.P.

By: _____

Allen M. Lo
Allen M. Lo
Reg. No.: 37,059

Date: December 6, 1996



UNITED STATES PATENT APPLICATION

OF

DENNIS CAMERON, WALT ROEHR,
RADE PETROVIC, JAI ~~ELGAT~~, MASOOD GARAH,
WILLIAM D. HAYS, and DAVID W. ACKERMAN

FOR

A NATIONWIDE COMMUNICATION SYSTEM

LAW OFFICES
FINNEGAN, HENDERSON
FARABOW, GARRETT
& DUNNER
1300 I STREET, N. W.
WASHINGTON, DC 20005
1 202 408-4000

08/260457

899,476

15 c/1
10/1



BACKGROUND OF THE INVENTION

A. Field of the Invention

5 The present invention relates to methods and systems for providing two-way communication capability between a central network and a mobile unit over a relatively large area, and more particularly to such methods and systems which allow for rapid communication of large messages and efficient use of system resources.

B. Description of the Related Art

10 Conventional two-way portable/mobile wireless messaging systems often provide a variety of services to subscribers. Conventional messaging systems in particular provide one-way services using store and forward techniques to mobile receivers carried by the subscriber. A fundamental goal of two-way
15 messaging systems is to provide a network of interconnected transmitters and receivers which provides sufficient transmitted signal strength and receive capability to uniformly cover a geographic region. Some conventional messaging systems provide
20 the message to the user on a small viewing screen on the mobile unit.

25 However, such conventional systems often suffer from problems associated with low system throughput, evidenced by slow message delivery and message size limitations and do not provide an acknowledgment feature wherein the mobile unit transmits an acknowledgment signal to the system to acknowledge receipt of the message from the system. Generally, system throughput refers to

LAW OFFICES
FINNEGAN, HENDERSON
FARABOW, GARRETT
& DUNNER
1300 I STREET, N.W.
WASHINGTON, DC 20005
1-202-408-4000

1 the overall communication capability of a system as defined by the
total amount of message data from the system to the mobile units
transferred by the system during a given period of time divided by
the frequency bandwidth necessary to transmit the message data and
5 may be measured in bits transferred per Hz. Further, such
conventional systems suffer from technical problems preventing
consistent wide area coverage and would require extremely wide
portions of valuable frequency bandwidth to achieve acceptable
system throughput rates.

10 Simulcast technology in communication systems was originally
developed to extend transmitter coverage beyond that which could
be obtained from a single transmitter. Over time, however,
simulcasting has evolved into a technique capable of providing
continuous coverage to a large area.

15 Generally, simulcast technology provides multiple
transmitters, operating on substantially the same frequencies and
transmitting the same information positioned to cover extended
areas. As shown in Fig. 1, transmitter 100 generally provides
coverage over area A, D, and E, transmitter 102 generally provides
20 coverage over area B, D, and E, and transmitter 104 generally
provides coverage over area C, E, and F. In some cases, the
coverage area of a first transmitter may be entirely enclosed
within the coverage area of another transmitter, such as in
building interiors and valleys. In areas where one (and only one)
25 transmitter dominates (e.g., areas A, B, and C in Fig. 1),
simulcast is effective because the other transmitters do not
significantly affect receivers in those areas.

LAW OFFICES
FINNEGAN, HENDERSON
PARBOW, GARRETT
& DUNNER
1300 I STREET, N.W.
WASHINGTON, DC 20005
1-202-408-4000

30

- 2 -

1
5
10
15
20
25
30

However, in "overlap" areas D, E, and F shown in Fig. 1, where the signals from two or more transmitters are approximately equal, problems can arise because destructive interference of signals occurs in these overlap areas such as areas D, E, and F. Destructive interference occurs when the two signals are equal in magnitude and 180° out of phase and completely cancel each other. While there were some successes, reliable design procedures were not available.

Attempting to precisely synchronize the carrier frequencies of all simulcast transmitters does not overcome the problem because points (i.e. nodes) at which destructive summing occurred persisted for long periods of time. At such points, a mobile receiver can not receive the simulcast signal.

Deliberately offsetting the carrier frequencies of adjacent transmitters can ensure that destructive interference does not persist at one point for an extended period of time. The slight errors in frequency displayed by high quality reference oscillators (e.g., 20 hertz errors in 100 MHz signals or a few parts in 10⁷) render deliberate offsetting unnecessary. Further, merely offsetting the carrier frequencies could not guarantee acceptable quality demodulation because proper alignment of the modulating signals in time is also required.

Fig. 2 displays the situation at, for example, point D in Fig. 1 when modulating waveforms are synchronized and includes coverage boundary 202 from a first transmitter and a second transmitter coverage boundary 204 from a second adjacent transmitter. An equi-signal boundary 200 exists where the signals

LAW OFFICES
FINNEGAN, HENDERSON
FARABOW, GARRETT
& DUNNER
1300 I STREET, N.W.
WASHINGTON, DC 20005
1-202-406-4000

(/ - 3 -

1
5
10
15
20
25
30

from the first and second transmitters have approximately equal signal strengths. A more realistic equi-signal boundary would take into account natural and man-made topography and propagation conditions, and therefore would probably not be a straight line.

Figs. 3 and 4 generally illustrate various signals as they may occur at or near the equi-signal boundary 200 as shown in Fig. 2. In particular, Figs. 3 and 4 illustrate various aspects of modulation synchronization and how altering transmission parameters may affect the synchronization. In general, there are at least three sources which cause the signals from the first transmitter and the second transmitter to be out of synchronization: (1) timing shifts in the delivery of the modulating waveform to each of the transmitters; (2) timing shifts internal to each transmitter; and (3) timing shifts caused by propagation distances and anomalies. From the perspective of a receiver located in an overlap area, these three sources of timing shifts combine to produce an overall timing shifts between the received signals from the first and second transmitters. In current commercial practice, the summation of these three components results in time shifts of about 200 microseconds. The timing shift present in simulcast systems disadvantageously limits the baud rate at which information may be transferred. In general, Figs. 3 and 4 will also illustrate how timing shifts prevents high baud rate transmissions.

A time line representation of a signal 306 from a first transmitter is shown in Fig. 3(A) and a signal 308 from a second transmitter is shown in Fig. 3(B), both from the perspective of a

LAW OFFICES
FINNEGAN, HENDERSON
FARABOW, GARRETT
& DUNNER
1300 I STREET, N.W.
WASHINGTON, DC 20005
11202-438-4000

1 receiver located in an overlap area. Vertical dashed lines 300
represent baud intervals on the time axis. As can be seen from
Figs. 3(A) and (B), the signals 306 and 308 are frequency
5 modulated between a high and a low frequency value and the signals
306 and 308 are exactly in phase. As will be appreciated, the
timing shift between signals 306 and 308 must be small when
compared to the baud interval shown in Figs. 3(A) and (B) since
signals 306 and 308 are in synchronization. Of course, as the
10 baud interval decreases, the timing shifts will likely cause
signals 306 and 308 to be out of synchronization.

Figs. 3(C), (D), and (E) show the summation of these two
signals 306 and 308 at an equi-signal boundary, such as boundary
200 in Fig. 2. Fig. 3(C) shows a composite signal 310 indicating
that the frequency information remains unchanged, Fig. 3(D) shows
15 a linear graph 312 of the relative phase difference caused by a
slight carrier frequency difference between the signals from the
first transmitter and the second transmitter. Fig. 3(E) shows a
composite amplitude signal 314. A noise threshold is indicated by
the horizontal dashed line 304 in Fig. 3(E).

20 Of interest, Fig. 3(E) shows the composite amplitude signal
314 dipping below the noise threshold 304 at an anti-phase
condition 302 (e.g., when the relative phase angle is $\pm 180^\circ$, as
shown in Fig. 3(D)). As can be seen from Fig. 3(E), the
anti-phase condition 302 caused by the slight phase shift between
25 transmitter 1 and transmitter 2 will not cause any loss of data
because the anti-phase condition persists for only a small portion
of the baud interval.

LAW OFFICES
FINNEGAN, HENDERSON
FARABOW, GARRETT
& DUNNER
1300 I STREET, N.W.
WASHINGTON, DC 20005
1-202-408-4000

30

6 - 5 -

1 The slight offset of the carrier frequencies between the
first and second transmitters causes a slow drift of the relative
phase of the two signals, as shown in Fig. 3(D). When the signals
are $\pm 180^\circ$ out of phase, the temporary dip in the amplitude
5 signal may cause the loss of a few bits in the composite signal,
at worst. These errors can be counteracted with a conventional
error correcting code, such as is commonly known.

10 Fig. 4 shows a set of similar signals to those in Fig. 3, but
wherein the signal 402 from the first transmitter is offset from,
or out of synchronization with, the signal 404 from the second
transmitter by a full baud. In particular, signal 404 lags signal
402 by one baud interval. As previously discussed, the offset of
signals 402 and 404 may be caused by various timing shifts in the
15 delivery of both signals 402 and 404 to a receiver in an overlap
area. Figs. 4(A) and (B) illustrate the extreme case where the
sum of these timing shifts is equal to the baud interval shown by
dashed lines 400. As can be seen in Fig. 4(C), composite signal
406 includes a period of indeterminate frequency which undesirably
covers several entire baud intervals and, therefore, successful
20 demodulation is impossible during those baud intervals. If the
baud interval were increased to minimize the effect of these
timing shifts, data loss would be less likely. Therefore, it can
be seen that the baud rate at which good data transfer can be
accomplished is limited by the timing shifts between signals
25 delivered to receivers in overlap areas.

LAW OFFICES
FINNEGAN, HENDERSON
PARABOW, GARRETT
& DUNNER
1300 I STREET, N.W.
WASHINGTON, DC 20005
1-202-406-4000

1 Through these examples, it can be seen that high degrees of
modulation synchronization make it possible to obtain good data
demodulation in a simulcast system. However, the baud rate
5 limitation of simulcast systems is a significant drawback and
limits system throughput.

 An alternative to simulcast for wide area coverage is
assignment of orthogonal, non-overlapping subdivisions of the
available system capacity to adjacent areas. Subdivisions can be
made in time (e.g., broadcasting the information on the same
10 frequency in different time slots to adjacent areas), or in
frequency (e.g., broadcasting the information simultaneously on
different frequencies in adjacent areas). There are several
problems with such orthogonal systems, however. First, orthogonal
assignments require tuning the receiver to the assigned frequency
15 or time channel for the area in which the receiver currently
resides. In the broadcast services every traveler has experienced
the frustration of finding the correct channel for their favorite
programs. Simulcast operation avoids the need for scanning and
re-tuning as the mobile unit moves between areas. Such scanning
20 and re-tuning also disadvantageously increases mobile unit power
consumption.

 Second, and more serious, the orthogonal assignment approach
drastically reduces the system throughput capacity as measured in
bits per Hz because anywhere from 3 to 7, or possibly more,
25 orthogonal assignments are required to obtain continuous area
coverage in most conventional orthogonal systems. This waste of
capacity is somewhat recouped if the same information is not

LAW OFFICES
FINNEGAN, HENDERSON
FARABOW, GARRETT
& DUNNER
1300 I STREET, N.W.
WASHINGTON, DC 20005
1-202-409-4000

30

- 7 -

1 needed throughout the service area because a given piece of
information is sent only to those cells where it is needed.

Conventional cellular radio service is a typical example of
an orthogonal system. In cellular, the same frequencies are
5 reused in spatially separated cells to allow different data to be
transmitted to different mobile units. An example of three
cellular arrangements is shown in Fig. 5 where the number of cells
(N) is equal to 3, 4, and 7. Each cell (i.e., A, B, C, . . .) in
conventional cellular service usually only includes a single
10 transmitter and operates in a different frequency or time division
within the communication protocol. As shown in Fig. 5, cellular
service generally locates transmitters utilizing the same division
(all the "A" transmitters) far enough apart to reduce the
likelihood of interference between such transmitters. As the
15 number of cells increases, the likelihood of interference
decreases. For example, with N=3 as shown by arrangement 500 in
Fig. 3, the distance between the coverage area of "A" cells is
about $\frac{1}{2}$ cell width, with N=4 in arrangement 502, the distance
between the coverage areas of "A" cells is slightly larger, and
20 with N=7 in arrangement 504 the distance between "A" cells is
larger than the width of one cell.

However, as the number of cells increases, the length of the
individual time intervals per cell decreases for time division
multiplexed systems, thereby decreasing the systems total
25 information transfer. In frequency division systems, more cells
undesirably increases the frequency bandwidth required.
Therefore, system throughput in bits per Hz is decreased as the

LAW OFFICES
FINNEGAN, HENDERSON
FARABOW, GARRETT
& DUNNER
1300 I STREET, N.W.
WASHINGTON, D.C. 20005
1-202-405-4000

30

7 - 8 -

1 number of cells increases. Furthermore, cellular systems often
require an electronic "handshake" between system and mobile unit
to identify the specific cell (i.e. transmitter) in which the
mobile unit is located to allow capacity reuse.

5 II. SUMMARY OF THE INVENTION

The systems and methods of the present invention have a wide
variety of objects and advantages. The systems and methods of the
present invention have as a primary object to provide a
communication system with wide area coverage and high message
10 throughput while minimizing frequency bandwidth usage.

It is an object of the invention to provide a simulcast
communication system with a high data transfer rate which does not
exceed the baud rate limitations of simulcast transmission.

15 It is a further object of the present invention to provide a
communication system which provides for superior data
communication integrity.

Yet another object of the invention is to provide a mobile
transceiver unit which prevents unnecessary RF interference,
particularly on commercial aircraft.

20 Still further, it is an object of the invention to provide a
zone based communication system which may dynamically redefine
zone boundaries to improve information throughput.

Another object of the invention is to provide a zone based
simulcast communication system which can effectively communicate
25 with both mobile transceiver units located near the center of each
zone as well as mobile transceiver units located within the
overlap areas between two or more zones.

LAW OFFICES
FINNEGAN, HENDERSON
FARABOW, GARRETT
& DUNNER
1300 I STREET, N.W.
WASHINGTON, D.C. 20005
1-202-406-4000

30

1 Additional objects and advantages of the invention will be
set forth in part in the description which follows, and in part
will be obvious from the description, or may be learned by
practicing the invention. The objects and advantages of the
5 invention will be realized and attained by means of the elements
and combinations particularly pointed out in the appended claims.

To achieve the objects and in accordance with the purpose of
the invention, as embodied and broadly described herein, the
invention is directed to a method for information transmission by
10 a plurality of transmitters to provide broad communication
capability over a region of space, the information transmission
occurring during at least both a first time period and a second
time period and the plurality of transmitters being divided into
at least a first and second set of transmitters, the method
15 comprising the steps of (a) generating a system information signal
which includes a plurality of blocks of information,
(b) transmitting the system information signal to the plurality of
transmitters, (c) transmitting by the first and second sets of
transmitters a first block of information in simulcast during the
20 first time period, (d) transmitting by the first set of
transmitters a second block of information during the second time
period, and (e) transmitting by the second set of transmitters a
third block of information during the second time period.

In another embodiment, the invention is directed to a
25 multi-carrier simulcast transmission system for transmitting in a
desired frequency band a message contained in an information
signal, the system comprising a first transmitter means for

LAW OFFICES
FINNEGAN, HENDERSON
PARABOW, GARRETT
& DUNNER
1300 I STREET, N.W.
WASHINGTON, DC 20005
1-202-406-4000

30

- 10 -

1 transmitting an information signal by generating a first plurality
of carrier signals within the desired frequency band and by
modulating the first plurality of carrier signals to convey the
information signal, and a second transmitter means, spatially
5 separated from the first transmitter, for transmitting the
information signal in simulcast with the first transmitter by
generating a second plurality of carrier signals at substantially
the same frequencies as the first plurality of carrier signals and
by modulating the second plurality of carrier signals to convey
10 the information signal.

In another embodiment, the invention is directed to a
communication method implemented in a computer controlled
communication network for locating a mobile transceiver within a
region of space, the region of space being divided into a
15 plurality of zones with each zone serviced by at least one base
transmitter and at least one base receiver, the network storing
data corresponding to a zone where the mobile transceiver was last
known to be located, the communication method comprising the steps
of (a) transmitting a message signal by a base transmitter
20 servicing a zone where the mobile transceiver was last known to be
located, (b) transmitting a systemwide probe signal by a plurality
of base transmitters servicing a plurality of zones if the mobile
transceiver does not indicate receipt of the message signal from
the base transmitter, (c) receiving the regional probe signal by
25 the mobile transceiver, (d) transmitting an acknowledgment signal
by the mobile transceiver in response to the received regional
probe signal, (e) receiving the acknowledgment signal from the

LAW OFFICES
FINNEGAN, HENDERSON
FARABOW, GARRETT
& DUNNER
1300 I STREET, N.W.
WASHINGTON, D.C. 20005
1-202-408-4000

30

12-11-

1 mobile transceiver by a base receiver, and (f) updating the data
to reflect the zone of the base receiver that received the
acknowledgment signal as the last known location of the mobile
transceiver.

5 In yet another embodiment, the invention is directed to a
method of communicating messages between a plurality of base
transmitters and mobile receivers within a region of space divided
into a plurality of zones with each zone having at least one base
transmitter assigned thereto, the communication method comprising
10 the steps of (a) transmitting substantially simultaneously a first
information signal and a second information signal to communicate
messages to the mobile receivers, the first information signal
being transmitted in simulcast by a first set of base transmitters
assigned to a first zone, and the second information signal being
15 transmitted in simulcast by a second set of base transmitters
assigned to a second zone, (b) dynamically reassigning one or more
of the base transmitters in the first set of base transmitters
assigned to the first zone to the second set of base transmitters
assigned to the second zone as a function of the messages to be
20 communicated in an area, thereby creating an updated first set of
base transmitters and an updated second set of base transmitters,
and (c) transmitting substantially simultaneously a third
information signal and a fourth information signal, the third
information signal being transmitted in simulcast by the updated
25 first set of base transmitters, and the fourth information signal
being transmitted in simulcast by the updated second set of base

LAW OFFICES
FINNEGAN, HENDERSON
FARABOW, GARRETT
& DUNNER
1300 I STREET, N.W.
WASHINGTON, DC 20005
30 1-202-468-4000

12-12-

1 transmitters to communicate additional messages to said mobile receivers.

5 In another embodiment, the invention is directed to a mobile transceiver unit for transmitting messages to and receiving messages from a network comprising input means for allowing the user to input a user message to the unit, transmitter means for transmitting a radio frequency signal including the user message from the mobile unit to the network, receiver means for receiving radio frequency signals having a message from the network, signal detector means for detecting at least one type of electromagnetic signal generated external to the mobile unit and the network, and a circuit, connecting the signal detector means to the transmitter means, for disabling the transmitter means upon detection of the electromagnetic signal, thereby preventing unwanted radio frequency transmission.

15 In another embodiment, the invention is directed to a communication method for controlling a mobile transceiver which may communicate with a communication network controlled by a computer, the network including a plurality of base transmitters for transmitting messages from the network to the mobile transceiver and base receivers for receiving messages from the mobile transceiver, the mobile transceiver being capable of sending a registration signal to be received by a base receiver in the network to identify the mobile transceiver's location and the plurality of base transmitters in the network being capable of sending a probe signal to the mobile transceiver to cause the mobile transceiver to transmit a signal to a base receiver to

LAW OFFICES
FINNEGAN, HENDERSON
FARABOW, GARRETT
& DUNNER
1300 I STREET, N.W.
WASHINGTON, D.C. 20005
1-202-408-4000

30

11 - 13 -

1 identify its location, the method comprising the steps of
(a) sending a message from the network to the mobile transceiver
to disable the mobile transceiver's capability to transmit a
registration signal, (b) storing the number of probe signals sent
5 by the network to the mobile transceiver during a first period of
time and the number of messages successfully delivered to the
mobile transceiver by the network during a second period of time,
(c) processing by the computer the stored number of probe signals
and number of messages successfully delivered to evaluate a
10 likelihood that a probe signal will be required to be sent by the
network to locate the mobile unit to deliver a message, and
(d) sending a message to the mobile unit to enable the mobile
transceiver's capability to transmit a registration signal if the
calculated likelihood exceeds a selected value.

15 Finally, in another embodiment, the invention is directed to
a communication method for controlling a mobile transceiver which
may communicate with a communication network controlled by a
computer, the network including a plurality of base transmitters
for transmitting messages to the mobile transceiver and base
20 receivers for receiving messages from the mobile transceiver, the
mobile transceiver being capable of sending a registration signal
to be received by a base receiver in the network to identify the
mobile transceiver's location, the network using received
registration signals to determine a set of base transmitters to be
25 operated to transmit a message to the mobile transceiver, the
method comprising the steps of (a) sending a message from the
network to the mobile transceiver to enable the mobile

LAW OFFICES
SINNEGAN, HENDERSON
FARABOW, GARRETT
& DUNNER
1000 I STREET, N.W.
WASHINGTON, DC 20005
1-202-462-4000

30

- 14 -

1 transceiver's capability to transmit a registration signal,
(b) storing the number of registration signals from the mobile
transceiver to the network during a first period of time and the
number of messages successfully delivered to the mobile
5 transceiver by the network during a period of time, (c) processing
the stored number of registration signals and number of messages
successfully delivered to evaluate a likelihood that a
registration signal from said mobile unit will not be used by the
network to determine a set of base transmitters, and (d) sending a
10 message to the mobile unit to disable the mobile transceiver's
capability to transmit a registration signal if the likelihood
exceeds a selected value.

It is to be understood that both the foregoing general
description and the following detailed description are exemplary
and explanatory only and are not restrictive of the invention, as
15 claimed.

III. BRIEF DESCRIPTION OF THE DRAWINGS

The accompanying drawings, which are incorporated in and
constitute a part of this specification, illustrate several
embodiments of the invention and together with the description,
20 serve to explain the principles of the invention.

Fig. 1 is a schematic diagram of an arrangement of simulcast
transmitters;

25 Fig. 2 is a schematic diagram of uniform smooth earth
propagation;

Fig. 3 is a schematic diagram of synchronized modulated
waveforms;

LAW OFFICES
PINNEGAN, HENDERSON
FARABOW, GARRETT
& DUNNER
1000 I STREET, N.W.
WASHINGTON, D.C. 20005
1-202-408-4000

30

16 - 15 -

1 Fig. 4 is a schematic diagram of modulated waveforms offset a
full baud;
Fig. 5 is a schematic diagram of cellular system coverage;
Fig. 6 is a schematic diagram of a communication system;
5 Fig. 7 is a flow chart of a preferred method of
communication;
Fig. 8 is a flow chart of a preferred method of sending a
regional probe signal;
Fig. 9 is a schematic diagram of a frequency spectrum for
10 multi-carrier modulation;
Fig. 10 is a schematic diagram of an on/off keying modulator;
Fig. 11 is a schematic diagram of a frequency shift keying
modulator;
Fig. 12 is a schematic diagram of a four carrier quadrature
15 modulator;
Fig. 13 is a schematic diagram of a first embodiment of a
base transmitter;
Fig. 14 is a schematic diagram of a second embodiment of a
base transmitter;
20 Fig. 15 is a schematic diagram of a mobile transceiver;
Fig. 16 is a pictorial representation of a mobile
transceiver;
Fig. 17 is a schematic diagram of a mobile receiver;
Fig. 18(A) is a schematic diagram of an analog base receiver;
25 Fig. 18(B) is a schematic diagram of a digital base receiver;
Fig. 19 is a schematic diagram of a base receiver with a
store and forward feature;

LAW OFFICES
FINNEGAN, HENDERSON
FARABOW, GARRETT
& DUNNER
1300 I STREET, N. W.
WASHINGTON, DC 20005
1-202-408-4000

30

17-16-

File History Content Report

The following content is missing from the original file history record obtained from the United States Patent and Trademark Office. No additional information is available.

Document Date - 1996-12-06

Document Title - Specification

Page(s) - 17

This page is not part of the official USPTO record. It has been determined that content identified on this document is missing from the original file history record.

1
5
10
15
20
25
30

IV. DESCRIPTION OF THE PREFERRED EMBODIMENTS

Reference will now be made in detail to the present preferred embodiments and exemplary embodiments of the invention, examples of which are illustrated in the accompanying drawings. Wherever possible, the same reference numbers will be used throughout the drawings to refer to the same or like parts.

A. Overview of The System Hardware

Fig. 6 shows an overview of the major elements of a preferred communication system according to the present invention. As shown therein, the communication system includes a network operations center 600 which is connected to a satellite uplink 602 via data path 604. A satellite uplink is used to provide data to satellite 606. Satellite 606 redirects the received data to several satellite downlink stations including station 608 and station 610. Conventional satellite technology allows for nominal data transfer rates of 24 M bits/second. Further, conventional satellite technology allows for accurate delivery of data to stations 608 and 610, which allows for precise synchronization between the signals broadcast in simulcast by the stations 608 and 610. It should be understood that stations 608 and 610 may optionally receive identical data, or may individually receive different data simultaneously from the satellite 606.

Satellite downlink stations 608 and 610 are connected to spatially separated base transmitters 612 and 614 via data paths 616 and 618, respectively. Base transmitter 612 is connected to antenna 620, and base transmitter 614 is connected to antenna 622. Preferably, the base transmitters of the present system have a

LAW OFFICES
FINNEGAN, HENDERSON
FARABOW, GARRETT
& DUNNER
1300 I STREET, N.W.
WASHINGTON, DC 20005
1-202-408-4000

1
b
Ins 5

power output capability of about 350 watts, which will provide an effective transmitter coverage area of several tens of miles. Although not shown in Fig. 6, ^{Each} each zone preferably includes multiple transmitter stations as will be evident from the following discussion. ¹⁰¹

10

Mobile unit 624 is connected to antenna 626 and, in the preferred embodiment, is a small, portable unit capable of being carried easily by a user and therefore is similar to conventional pagers in those aspects. More preferably, the mobile unit has both receive and transmit capability, with a nominal transmit power output of about 1 watt.

15

The communication system includes several base receivers 628, 630, 632, and 634 each connected to antennas 636, 638, 640, and 642, respectively. Base receivers 628 and 630 are connected to a regional station 644 via data paths 646 and 648, respectively. Base receivers 632 and 634 are connected to regional station 650 via data paths 652 and 654, respectively. Base transmitters 612, 614 preferably have a large transmit power output capability to provide coverage to the mobile unit in areas to which

20

communication is typically difficult, such as building interiors, and to extend the coverage area of each transmitter. An appropriate number of base receivers should be dispersed

25

throughout the geographic area to reliably receive the signals from the mobile unit. Due to the difference in output power between base transmitters and mobile units, an overall ratio of 10 base receivers to 1 base transmitter may be appropriate, and the 2

LAW OFFICES
FINNEGAN, HENDERSON
FARABOW, GARRETT
& DUNNER
1300 I STREET, N.W.
WASHINGTON, DC 20005
30-202-408-4000

1
5
10
15
20
25
30

to 1 ratio shown in Fig. 6 is merely shown for ease of illustration.

Regional station 650 is connected to the network operations center 600 via data path 656 and regional station 644 is connected to the network operations center 600 via data path 658. The data paths 656 and 658 preferably include low cost phone lines, but may include any convenient and appropriate data transfer technology.

Generally, the communication system of the present invention roughly divides various regions of space into portions called zones. Each zone must have one or preferably more base transmitters assigned to it. Zone boundaries are roughly defined by the transmitter coverage areas of the base transmitters assigned to that zone. For example, Fig. 6 shows a dashed zone dividing line 660 roughly dividing a zone 1 from a zone 2. Zone 1 includes base transmitter 614, base receivers 632 and 634, regional station 650, and mobile unit 624. Zone 2 includes base transmitter 612, base receivers 628 and 630, and regional station 644. Dashed line 660 only roughly defines the boundary between zones because precise boundaries do not exist. For example, to insure adequate coverage of the region, as shown in Fig. 1, the range of both transmitter 614 should at least cover the region above dashed line 660, and preferably should extend somewhat below dashed line 660. Similarly, the range of base transmitter 612 should at least cover the region below dashed line 660, and preferably should extend somewhat above dashed line 660. As can be seen, an overlap of transmitter coverage may occur in the vicinity of dashed line 660.

LAW OFFICES
FINNEGAN, HENDERSON
FARABOW, GARRETT
& DUNNER
1300 I STREET, N.W.
WASHINGTON, DC 20005
1-202-408-4000

1

Referring back to Fig. 2, it can be seen that boundary 202 and boundary 204 overlap in an area near the equi-signal 200 and between these boundaries which may be termed an "overlap area." In Fig. 6, dashed line 660 is drawn near the may be defined as the equi-signal boundary between base transmitter 614 and base transmitter 612. Of course, dashed line 660 does not represent the overlap area that may occur between base transmitter 614 and base transmitter 612.

5

10

15

20

As explained in the Background of the Invention section, if base transmitters 612 and 614 are broadcasting identical signals on the same frequencies in simulcast, good reception by a receiver located near the dashed line 660, and possibly in an overlap area (not shown), can be achieved. Simulcast thus may provide uniform transmitter coverage for the region shown in Fig. 6. However, if base transmitter 612 is broadcasting a first information signal and base transmitter 614 is broadcasting a different, second information signal on identical frequencies simultaneously, it will likely be difficult for a receiver located in the overlap area to receive either the first or the second information signal. In this instance, the overlap area may be referred to as an interference area because a receiver in this area would receive a composite signal, including the first and second information signal, that would likely be unusable.

25

LAW OFFICES
 FINNEGAN, HENDERSON
 FARABOW, GARRETT
 & DUNNER
 1300 I STREET, N.W.
 WASHINGTON, D.C. 20005
 1-202-406-4000

The following will be an exemplary discussion of the various interactions of the elements of the communication system when delivering a message to mobile unit 624. In accordance with the invention, a preferred method 700 of this interaction is shown in

30

1 Fig. 7. Network operations center 600 generates a system
information signal of several blocks of information as shown in
step 702. The blocks of information include an electronic message
to be delivered to the mobile unit 624.

5 In step 704, the system information signal is transmitted to
the base transmitters. In particular the network operations
center 600 provide the system information signal and appropriate
other data to the satellite uplink 602 via data path 604 for
transmission to the satellite 606. The data is then received and
10 retransmitted by satellite 606 to satellite downlink stations 608
and 610. The data received by satellite downlink 608 is provided
to base transmitter 612 through data path 616, and the data
received by satellite downlink 610 is provided to base transmitter
614 through data path 618.

15 At this point, the exemplary communication system shown in
Fig. 6 may transfer the message to the mobile unit during one of
two time intervals. In the first time interval, both base
transmitter 612 and base transmitter 614 transmit data via antenna
620 and antenna 622, respectively, in simulcast to be received by
20 mobile unit 624, which corresponds to step 706 in Fig. 7. This
first alternative may be useful to deliver the message if, for
example, the location of mobile unit 624 in zone 1 or zone 2 is
unknown and broad coverage is desired.

25 In the second time interval, base transmitter 614 transmits a
block of information including the message data to mobile unit 624
and base transmitter 612 transmits another block of information,
which corresponds to steps 708 and 710 of Fig. 7. This second

LAW OFFICES
FINNEGAN, HENDERSON
FARABOW, GARRETT
& DUNNER
1300 I STREET N.W.
WASHINGTON, DC 20005
1-202-408-4000

30

- 22 -

1 alternative may be useful if, for example, the mobile unit 624 is
known to be located in zone 1 and out of range of base transmitter
612. Delivery of the message to mobile unit 624 during the second
time interval is advantageous because during message delivery to
5 the mobile unit 624 by base transmitter 614, base transmitter 612
could be delivering a different message to a different mobile unit
(not shown). As can be seen, this second alternative would
increase information throughput and system efficiency.

10 If the mobile unit 624 has properly received the message via
antenna 626, then the mobile unit 624 may generate a return signal
and broadcast that signal via antenna 626. The return signal may
be received by any or several of the base receivers 628, 630, 632,
or 634. For example, the return signal could be received by base
receiver 632 through antenna 640 if antenna 640 is located closer
15 to the mobile units than any other antenna 636, 638, or 642. In
this case, the base receiver would receive the return signal and
provide it to regional station 650 through data path 652. The
regional station would then provide the return signal to the
network operations center 600 through data path 656 for further
20 processing as appropriate. It should be understood that a return
signal may include either an autonomous acknowledgment signal
which indicates that the mobile unit accurately received the
message or a user generated reply signal.

25 If the mobile unit 624 does not completely receive the
message, it can generate and broadcast a negative acknowledge
signal. The negative acknowledge signals when delivered to the

LAW OFFICES
FINNEGAN, HENDERSON
FARABOW, GARRETT
& DUNNER
1200 I STREET, N.W.
WASHINGTON, DC 20005
30 202 402 4000

1 network operations center 600, indicates that retransmission of
the message is necessary.

It should be understood that the exemplary system shown in
Fig. 6 includes a modest number of elements for ease of
5 explanation. It is envisioned that the system of the present
invention include a large number of base transmitters, base
receivers, regional stations, and mobile units with a substantial
number of base transmitters assigned to each zone and all base
transmitters assigned to a particular zone operating in simulcast.
10 Further, it is envisioned that the present system could
advantageously support a large number of zones to cover a wide
geographic area.

B. Overview of the Zonal Simulcast Concepts

The preferred systems and methods of the present invention
15 variously use simulcast techniques within individual zones and
over several or all of the zones. As previously noted, zones are
generally defined by the coverage areas of the one or more base
transmitters. The network operations center 600 assigns each base
transmitter in the system to a zone. For example, in Fig. 6, base
20 transmitter 614 is assigned to zone 1, and the base transmitter
612 is assigned to zone 2 by the network operations center 600.
To maximize information throughput, the systems and methods of the
present invention dynamically control zonal assignments and the
use of simulcast techniques.

25 In general, the communication system of the present invention
operates by repeating a communication cycle to achieve desired
information transfer, which is more fully discussed infra. The

LAW OFFICES
FINNEGAN, HENDERSON
FARABOW, GARRETT
& DUNNER
1300 I STREET, N.W.
WASHINGTON, DC 20005
1-202-409-4000

30

27 - 24 -

1 communication cycle is divided into a systemwide time interval and
a zonal time interval. In the systemwide time interval, the base
transmitters from at least several zones are operated in simulcast
to simultaneously transmit identical information to a large
5 geographic area. It should be understood that the systemwide time
merely two or more zones.

Broadly speaking, the communication system need not know the
location of a mobile unit to transmit to it during the systemwide
time interval. Therefore, the systemwide time interval can be
used to send a "probe" signal that requests a particular mobile
10 unit to broadcast an acknowledgment signal to allow the system to
determine its approximate location by determining which base
receiver receives the acknowledgment signal. Probe signals,
thereby, may be used to track the locations of mobile units, or to
15 uncover the location of "lost" mobile units.

In the zonal time interval, each base transmitter assigned to
a particular zone transmits identical information in simulcast.
However, for mobile units at or near the interference areas
between adjacent zones, poor communication to those mobile units
20 is likely during the zonal time interval because transmitters in
adjacent zones will be simultaneously transmitting different data
on the same, or substantially the same, frequencies. The zonal
time interval provides good communication capability for mobile
units not located near the zonal boundaries and allows the system
to "reuse" identical frequencies in adjacent zones. Furthermore,
25 if zonal boundaries are selected to be located in areas where
mobile units are not likely to be located, i.e. unpopulated areas,

LAW OFFICES
FINNEGAN, HENDERSON
FARABOW, GARRETT
& DUNNER
1200 I STREET N.W.
WASHINGTON, DC 20005
1-202-408-4000

30

- 25 -

1 the likelihood of providing good communication capabilities to a
large percentage of mobile units can be increased.

As can be seen, from a system perspective, it is desirable to
communicate with the mobile units in the zonal time interval
5 because information throughput is maximized by reusing the
transmission frequency band in the several zones. In other words,
using the zonal time interval allows communication with a large
number of mobile units in a short amount of time. Accordingly,
communication during the systemwide time interval should be
10 minimized because message transmission during this interval
requires a large amount of system resources be dedicated to that
message.

For mobile units located near the boundaries between zones
where interference is likely during the zonal time interval, good
15 communication capability can be achieved for these units during
the systemwide time interval. In the preferred systems and
methods, when a mobile unit fails to acknowledge a message sent
during the zonal time interval or provides a negative
acknowledgment, the network operations center sends a probe signal
20 during a subsequent systemwide time interval to determine the
location of that mobile unit. If the location of the mobile unit
indicates that a likely reason for the failure of the mobile unit
to receive the message is caused by inter-zonal interference, the
network operations center may simply retransmit the message during
25 the systemwide time interval. In other instances, the failure to
successfully deliver a message may be simply caused by the mobile
unit being located in a weak signal area within a zone. In these

LAW OFFICES
FINNEGAN, HENDERSON
FARABOW, GARRETT
& DUNNER
1200 I STREET, N.W.
WASHINGTON, D.C. 20005
1-202-408-4000

30

27 - 26 -

1 instances, the system may retransmit the message during the zonal
time interval using an appropriate error correcting code or using
a stronger error correcting code.

5 Alternatively, the network operations center may determine
from the probe signal that the mobile unit is simply located in a
different zone than the zone that the message was first sent. In
this case, the network operations center preferably causes the
message to be retransmitted in the appropriate zone without again
using a portion of the valuable systemwide time interval.

10 In accordance with the invention, a preferred method 800 for
sending a probe signal is shown in Fig. 8. In step 802, a message
signal is transmitted by a base transmitter servicing a zone where
the mobile transceiver was last known to be located. In
particular, this may be preferably an attempt by the network to
15 deliver a message to the mobile transceiver.

If the mobile transceiver does not indicate receipt of the
message signal from the base transmitter transmitted in step 802,
the network assumes that the mobile transceiver has not received
the message and transmits a probe signal by a plurality of base
20 transmitters servicing a plurality of zones in step 804. The
mobile transceiver receives the probe signal in step 806.

Upon receipt of the probe signal by the mobile transceiver,
the mobile transceiver transmits an acknowledgment signal in step
808. A base receiver receives the acknowledgment signal from the
25 mobile transceiver in step 810.

LAW OFFICES
FINNEGAN, HENDERSON
FARABOW, GARRETT
& DUNNER
1100 I STREET, N.W.
WASHINGTON, DC 20005
1 202 408-4000

1
5
10
15
20
25

Finally, the data, such as the last location field 2104 shown in user database 2100, is updated to reflect the zone of the base receiver, or receivers, that receives the acknowledgment signal as the last known location of the mobile transceiver in step 812.

C. The Multi-Carrier Modulation Transmission Format

The base transmitters of the communication system, such as base transmitters 612 and 614 shown in Fig. 6, preferably utilize a multi-carrier modulation format as will now be described. In general, a multi-carrier modulation format envisions the simultaneous transmission of several closely spaced carrier frequencies within a desired frequency band, each individually modulated to convey an information signal. The multi-carrier modulation format advantageously allows for high data transfer rates by providing good bit rate transmission rates while keeping below the baud rate limitations of simulcast transmission techniques.

Fig. 9 shows a frequency representation 900 of an eight carrier modulation format. Carrier frequency 902 is shown with side bands 904, carrier frequency 906 is shown with side bands 908, carrier frequency 910 is shown with side bands 912, carrier frequency 914 is shown with side bands 916, carrier frequency 918 is shown with side bands 920, carrier frequency 922 is shown with side bands 924, carrier frequency 926 is shown with side bands 928, and carrier frequency 930 is shown with side bands 932.

LAW OFFICES
FINNEGAN, HENDERSON
FARABOW, GARRETT
& DUNNER
1200 I STREET, N.W.
WASHINGTON, DC 20005
1-202-408-4000

26

1 It should be understood that although this exemplary figure shows an eight carrier signal modulation format, other different numbers of carrier frequencies may be considered for use in the systems and methods of the present invention.

5 In this exemplary embodiment, the carrier frequencies are spaced 3 KHz apart within a desired frequency band of 50 KHz. Dashed line skirts 934 and 936 represent minimum frequency roll off levels, such as may be required by Federal Communication Commission regulations, to prevent overlap interference into adjacent frequency bands.

10 Because eight unique data streams may be modulated onto the respective eight carrier signals in this embodiment, the data transfer rate of the transmission from the base transmitters can be greatly increased, while keeping the baud rate within acceptable ranges for simulcast transmission. It should also be understood that in accordance with good simulcast practice, the respective carrier frequencies between adjacent base transmitters, such as base transmitter 612 and base transmitter 614 in Fig. 6, should be slightly offset to prevent sustained nodes or "dead spots" where destructive interference between the signals from each transmitter provides an unusable composite signal, as was explained in the background section of this application. This frequency offset is preferably on the order of 10-20 hertz.

20 As previously discussed, each carrier signal may be individually modulated to convey a data stream. The following will discuss alternative techniques for modulating a plurality of

25
LAW OFFICES
FINNEGAN, HENDERSON
FARABOW, GARRETT
& DUNNER
1300 I STREET, N.W.
WASHINGTON, DC 20005
30 202-408-4000

1 carriers in accordance with the systems and methods of the present invention.

1. Modulated On/Off Keying

5 Perhaps the simplest modulation scheme conceptually is modulated on/off keying (MOOK). Fig. 10 shows a schematic representation of a MOOK modulator 1000. The MOOK modulator 1000 includes a plurality of carrier frequency generating devices, such as frequency generator 1002 generating frequency F1, frequency generator 1004 generating frequency F2, frequency generator 1006 generating frequency F3, frequency generator 1008 generating frequency F4, and frequency generator 1010 generating frequency Fn. As shown in Fig. 10, the MOOK modulator 1000 may include any number (i.e. n) of frequency generators, but eight carrier frequencies are preferred, as shown in Fig. 9.

15 The output from each of the carrier frequency generators 102, 104, 106, 108, and 110 is applied to a plurality of respective switches SW1 812, SW2 814, SW3 816, SW4 818, and SWn 820. The output from each switch is provided to a combiner 1022.

20 Each of the switches SW1 812, SW2 814, SW3 816, SW4 818, and SWn 820 opens and closes under the control of a control logic system (not shown) to effect the MOOK modulation. The control logic system (not shown) causes the desired switches to variously close and open, thereby conveying an n-bit binary word. Each carrier frequency transmits a binary "one" if the respective switch is closed and a binary "zero" if the respective switch is open.

25
LAW OFFICES
FINNEGAN, HENDERSON
FARABOW, GARRETT
& DUNNER
1200 I STREET, N.W.
WASHINGTON, D.C. 20005
30 202 408-4000

1 The summer 1022 combines the modulated carrier frequencies to
provide a multi-carrier modulated output signal that conveys an
n-bit binary word.

2. Binary Frequency Shift Keying Modulation

5 An alternative multi-carrier modulation scheme including
frequency shift keying (FSK) techniques may be implemented by the
modulator shown in Fig. 11. A frequency shift keying modulator
1100 includes a first frequency source 1102, a second frequency
source 1104, a third frequency source 1106, a fourth frequency
10 source 1108, and an nth frequency source 1110. The output from
each frequency source is provided to a respective modulator 1112,
1114, 1116, 1118, and 1120.

 A control logic system (not shown) provides a frequency
control signal to each modulator to frequency shift modulate the
15 carrier frequencies. In particular, the control logic system (not
shown) provides frequency control signal 1 to modulator 1112,
frequency control signal 2 to modulator 1114, frequency control
signal 3 to modulator 1116, frequency signal 4 to modulator 1118,
and frequency control signal n to modulator 1120. In binary
20 frequency shift keying (BFSK), the respective frequency control
signals provide data corresponding to a binary "one" or "zero"
which causes the respective modulators to modulate a first or
second frequency onto the carrier signal.

 A summer 1122 combines the modulated carrier frequencies to
25 produce an output signal.

LAW OFFICES
FINNEGAN, HENDERSON
FARABOW, GARRETT
& DUNNER
300 I STREET, N.W.
WASHINGTON, D.C. 20005
1-202-406-4000

1

3. M'ary Frequency Shift Keying Modulation

5

A modulation scheme related to binary frequency shift keying is M'ary frequency shift keying. M'ary frequency shift keying modulates three or more different frequencies onto the respective carrier signals. In quaternary frequency shift keying, for example, two bits of information may be instantaneously conveyed on a single carrier frequency. Similarly, 8'ary frequency shift keying may instantaneously convey three bits of information per carrier frequency.

10

Referring again to Fig. 11, M'ary frequency shift keying may be implemented by providing modulators 1112, 1114, 1116, 1118, and 1120 with the capability to modulate M different frequencies onto the carrier signal. Accordingly, the various frequency control signals must provide data indicating which of the M frequencies is to be modulated onto the carrier signal. For example, in quaternary frequency shift keying, the frequency control signals must each include two bits of information to indicate which of the four different frequencies are to be modulated onto the carrier frequency.

15

20

The summer 1122 combines the modulated carrier frequencies to produce an output signal.

25

4. Quadrature Amplitude Multi-Carrier Modulation

Yet another alternative modulation technique for a multi-carrier transmission format is shown in Fig. 12. A quadrature modulator 1200 includes a first quadrature carrier generator 1202, a second quadrature carrier generator 1204, a third quadrature carrier generator 1206, and a fourth quadrature

LAW OFFICES
FINNEGAN, HENDERSON
FARABOW, GARRETT
& DUNNER
1300 I STREET, N.W.
WASHINGTON, DC 20005
1-202-462-4000

30

1 carrier generator 1208. As is well known, quadrature modulators
in general each produce an in-phase carrier signal and a
quadrature carrier signal that is +/- 90° out of phase with
reference to the in-phase signal. Of course, any number of
5 quadrature carrier generators could be envisioned, depending upon
data transfer and throughput needs. Fig. 12 shows four quadrature
carrier generations which effectively correspond to eight unique
modulator signals. Therefore, quadrature amplitude multi-carrier
modulation may preferably reduce the width of the frequency band
10 necessary to achieve a desired data transfer rate.

Each quadrature carrier generator 1202, 1204, 1206, and 1208
receives a control signal from a control logic system (not shown)
which provides the data to be modulated onto the quadrature
carrier signals. In a simple implementation, the quadrature
15 carrier generators may amplitude modulate the in-phase and
quadrature phase output signals to convey two bits of information.
The in-phase and quadrature signals output from each quadrature
carrier generators 1202, 1204, 1206, and 1208 are provided to a
summer 1210 which combines the signals to produce an output
20 signal.

5. Permutation Frequency Shift Keying (PFSK)

PFSK may be implemented through control logic systems similar
to that used in a MOOK or an M'ary FSK modulation scheme. In
PFSK, every baud has a fixed number of carrier signals present,
25 preferably any 4 of the possible 8. In a PFSK arrangement, a
constant average transmitter power is advantageously delivered and
the receiver only need decide which 4 carrier frequencies contain

LAW OFFICES
FINNEGAN, HENDERSON
FARABOW, GARRETT
& DUNNER
1300 I STREET, N. W.
WASHINGTON, DC 20005
1-202-408-4000

30

34 33 -

1 the most energy. In the case of MOOK, the receiver must attempt
to determine on a subchannel-by-subchannel basis the presence or
absence of a signal. This aspect of PFSK may simplify mobile
receiver design.

5 Compared to a binary or M'ary FSK modulation schemes, a
higher number of bits may be delivered per baud with PFSK. For
example, PFSK may generate signals that independent FSK
subchannels could never generate, such as all four carriers being
the four highest frequencies, and therefore it can be seen that
10 PFSK may advantageously increase information transfer rates.

D. The Base Transmitter

Each base transmitter unit, such as base transmitter 612 or
614 shown in Fig. 6, receives transmitter control data and message
data transmitted from the satellite 606. Fig. 13 shows a first
15 preferred embodiment of a base transmitter 1300 in accordance with
the present invention. The base transmitter 1300 receives data
from the satellite downlink connected to data input 1302 which
provides this data to a control logic system 1304 to control the
operation of the base transmitter unit. The control logic 1304
20 provides a control signal to a plurality of modulators 1306, 1308,
1310, 1312, and 1314. Modulator 1306 produces a carrier signal
F1, modulator 1308 produces a carrier signal F2, modulator 1310
produces a carrier signal F3, modulator 1312 produces a carrier
signal F4, and modulator 1314 produces a carrier signal Fn.

25 For example, the control logic may generate appropriate
control signals to modulate the carrier signals in a MOOK, BFSK,
M'ary FSK, PFSK, or quadrature amplitude modulation scheme, as

LAW OFFICES
FINNEGAN, HENDERSON
FARABOW, GARRETT
& DUNNER
1300 I STREET N.W.
WASHINGTON, D.C. 20005
1 202 468 4000

30

- 34 -

1 previously discussed. Each modulator then provides the modulated
output signal to a combiner 1316 which combines each of the
several modulated carrier frequencies into a single output signal.

5 The single signal is then applied to a power amplifier 1318
to amplify this signal to an appropriate level. The power
amplifier 1318 may, for example, produce a nominal output signal
of 350 watts to antenna 1320. In this embodiment, power amplifier
1318 preferably has extremely linear characteristics to prevent
10 formation of intermodulation products, and to insure that these
intermodulation products do not cause signals to be generated at
undesirable frequencies. Antenna 1320 broadcasts the desired
signal from power amplifier 1318.

15 Fig. 14 shows a second preferred embodiment of a base
transmitter unit. The second embodiment comprises a base
transmitter 1400 which includes a satellite downlink connected to
data input 1402, control logic 1404, and several modulators 1406,
1408, 1410, 1412, and 1414. Each modulator receives an
appropriate control signal from the control logic 1404, as
previously discussed with respect to base transmitter 1300.

20 The output from each of modulators 1406, 1408, 1410, 1412,
and 1414 in base transmitter 1400 is provided to respective power
amplifiers 1416, 1418, 1420, 1422, and 1424 to provide an
appropriate power output level for transmission, such as 350 watts
aggregate.

25
LAW OFFICES
FINNEGAN, HENDERSON
FARABOW, GARRETT
& DUNNER
700 I STREET, N.W.
WASHINGTON, DC 20005
1-202-408-4000

1 The output from each of power amplifiers 1416, 1418, 1420,
1422, and 1424 is provided to combiner 1426 to combine the
modulated carrier signals into a single output signal which is
provided to antenna 1428 for broadcast.

5 E. The Mobile Unit

 The mobile unit may be a small, portable mobile transceiver,
such as pictorially represented in Fig. 16. Referring now to
Fig. 15, the mobile transceiver 1500 shown therein includes a
receiver section for receiving signals from the base transmitters
10 of the system, and a transmitter section for transmitting replies,
or other messages, to the base receivers of the system.

 In particular, the mobile transceiver 1500 includes an
antenna 1502 which is connected to a transmit/receive switch 1504
to switch the antenna between the transmit and receive sections of
15 the mobile transceiver 1500. A receiver 1506 is provided to
receive the messages from the base transmitter. Of course, the
receiver must be appropriately designed to receive the
multi-carrier signals from the base transmitters and must be
appropriately designed to demodulate the particular modulation
20 scheme utilized. For example, appropriate analog filters and
appropriate demodulators could be used. In the preferred
embodiment, the receiver performs a transform, such as a fast
fourier transform, on the received signal to separate the data
from the various carriers in the multi-carrier modulation format.

25 The receiver 1506 is connected to a display and storage logic
section 1508 to process the received signal. An annunciator 1510
to alert the user that a message has been received is connected to

LAW OFFICES
FINNEGAN, HENDERSON
PARABOW, GARRETT
& DUNNER
1300 I STREET, N.W.
WASHINGTON, DC 20005
1-202-408-4000

30

- 36 -

1 and controlled by the display and storage logic 1508. The
annunciator 1510 may commonly include a sound producing device
such as a beeper, or a vibrator, or a flashing light.

5 A set of display controls 1512 to control the display of the
mobile transceiver 1500 is connected to the display and storage
logic 1508. A display 1514, preferably an LCD display, is also
connected to the display and storage logic 1508 to display
messages and various other information to the user.

10 Display and storage logic 1508 is connected to transmit logic
1518 via connection 1526. Display and storage logic 1508 may
generate an autonomous acknowledge signal which causes the
transmitter 1520 to broadcast an appropriately modulated RF
signal. As previously discussed, it is desirable for the mobile
transceiver to transmit an acknowledge signal if the message was
15 properly received by the mobile unit, or alternatively to transmit
a negative acknowledge signal if the message was only partially
received. The negative acknowledge signal indicates that the
network operations center should rebroadcast the message to the
mobile unit.

20 Preferably, the rebroadcast of the message to the mobile unit
should occur with an appropriate error correcting code which may
be decoded by the mobile unit to insure complete and accurate
reception of the message. Of course, error correcting codes
should be used only when necessary because their use slows data
transfer and increases the complexity of the mobile unit. Other
25 types of autonomous replies may also be useful, for example, to
indicate to the network operations center that the user has not

LAW OFFICES
FINNEGAN, HENDERSON
FARABOW, GARRETT
& DUNNER
1200 I STREET, N.W.
WASHINGTON, D.C. 20005
1-202-698-4000

30

38 - 37 -

1 viewed the message even though the mobile unit properly received
it, such as when the mobile transceiver is unattended by the user.

5 A set of input switches 1516 is provided to allow the user to
input a reply to a received message, or to otherwise generate a
message to be transmitted by the mobile transceiver. The input
switches are connected to transmit logic 1518 which decodes the
signal from the input switches 1516 to generate an output signal
to the transmitter 1520. The transmitter 1520 generates an
appropriately modulated RF signal to be broadcast by antenna 1502.

10 The mobile transceiver 1500 also preferably includes a noise
detector 1522. The noise detector 1522 provides an output signal
upon sensing through antenna 1502 a threshold level signal. The
noise detector 1522 provides an output signal to disable the
transmitter 1520 via connection 1524, and to thereby prevent
15 unwanted transmission by the mobile unit.

Noise detector 1522 preferably is set to detect
electromagnetic signals which are generated externally to the
communication system and which are indicative of a condition when
transmissions by the mobile unit are undesirable. For example,
20 the noise detector 1522 could be designed to serve a threshold
level of noise at 400 Hz. When the user enters a commercial
aircraft, which commonly uses 400 hertz power supply, the receipt
of this noise by the noise detector 1522 would then disable the
transmit capability of the mobile transceiver 1500 during
25 operation of the aircraft to prevent any unnecessary or unwanted
interference with the operations of the aircraft by autonomous or
intentional transmissions by the mobile transceiver 1500.

LAW OFFICES
FINNEGAN, HENDERSON
PARABOW, CARRETT
& DUNNER
1200 I STREET, N.W.
WASHINGTON, D.C. 20005
1 202 408 4000

30

- 38 -

1

The display and storage logic 1508 of the mobile transceiver 1500 further preferably includes a timing circuit (not shown) which may be used to turn the receiver section 1506 on or off, as desired. The timing circuit (not shown) advantageously allows the mobile transceiver to "power down" during periods of time when messages are not anticipated to be transmitted. For example, in a preferred communication protocol, the receiver could simply power up at the beginning of each cycle to receive data to determine if a message will be transmitted to that mobile transceiver during that cycle or when information concerning message availability will be transmitted. If the mobile transceiver is to receive a message, the timing circuit could power up at the appropriate time to receive the message, and then power down after receipt. The timing circuit, therefore, advantageously prolongs the battery life of the mobile transceiver 1500. Of course, it should be understood that the timing circuit could control the other elements of the mobile transceiver, such as the display 1514, and the transmit logic 1518.

5

10

15

20

25

LAW OFFICES
FINNEGAN, HENDERSON
FARABOW, GARRETT
& DUNNER
1300 I STREET, N.W.
WASHINGTON, DC 20005
1-202-408-4000

30

In an alternate implementation, the receiver 1506 may adaptively change its demodulation techniques to accommodate various formats. For example, each zone may advantageously use a different modulation format depending on message traffic levels, and other considerations. In particular, the receiver may receive a signal indicating the modulation scheme utilized in a given zone via a modulation format message contained in an overhead portion of the data stream. The demodulation of FSK, M'ary FSK, PFSK, and MOOK formats all begin with the determination of the energy levels

- 39 -

40

1 detected at each of the carrier frequencies, and thus require
identical processing of the received RF energy. The logic (not
shown) in the receiver interprets the meaning of these measured
energy levels based upon the modulation scheme selected as
5 indicated by the received modulation format message. In this
manner simpler and more economical transmitters, with a decreased
capacity for information transfer, can be used in zones that have
decreased traffic loads and more expensive, high-throughput
transmitters can be used only in those areas where they are
10 needed.

A pictorial representation of the mobile transceiver is shown
in Fig. 16. The mobile transceiver 1600 shown therein includes a
case 1602, a pair of display control buttons 1604, a display 1606,
and a set of six reply buttons 1608, 1610, 1612, 1614, 1616, and
15 1618. As indicated previously, display 1606 is preferably an LCD
display and a set of display control buttons 1604 may be used to
scroll text up or down on the display 1606. The message "will you
be home for dinner?" is shown on display 1606.

20 The set of six reply buttons 1608, 1610, 1612, 1614, 1616,
and 1618 provide a flexible system for user generated replies to
received messages. The display and storage logic 1508 provides
information immediately above each button indicating a possible
reply message by the user. In the simple example shown in
Fig. 16, the user may reply "yes," "no," or "?" to the message
25 1620 displayed on the screen 1606. The transmit logic 1518
generates an appropriate signal based upon which button the user

LAW OFFICES
FINNEGAN, HENDERSON
FARABOW, CARRETT
& DUNNER
1300 I STREET, N.W.
WASHINGTON, DC 20005
30-202-408-4000

1 presses. In this simple scenario, buttons 1614, 1616, and 1618
are unused.

5 In alternate applications, up to six possible reply messages
may be shown on the screen 1606. Of course, other particularized
applications may be envisioned for the reply feature of the mobile
transceiver 1500. For example, if the user is a stockbroker, the
display 1606 could display the terms "buy," "sell," or "hold"
above the appropriate buttons. A variety of other applications
may be envisioned.

10 With the six button reply option provided by mobile
transceiver 1500, a three bit message may be transmitted by the
mobile transceiver to the base receivers. The two remaining
states of the three bit message may be used by the transmit logic
1518 for the autonomous acknowledgment signal which indicates that
15 the message has been properly received, and for the autonomous
negative acknowledgment signal which indicates that the message
has not been completely or properly received.

20 Of course, the mobile transceiver 1500 shown in Fig. 16 could
be configured differently to provide more or less reply buttons,
different display control buttons, and different display formats
as desired or needed by the user.

25 Further, the mobile transceiver 1500 could additionally
include a data output port (not shown) for connection to other
electronic devices of the user. For example, the mobile
transceiver could be connected through an output port to a laptop
or palmtop PC, or could be incorporated therein. The PC could
display the message on its screen, thereby obviating the need for

LAW OFFICES
FRINNEGAN, HENDERSON
FARABOW, GARRETT
& DUNNER
1300 I STREET, N.W.
WASHINGTON, DC 20005
1-202-408-4000

30

42-41 -

1 the display 1606, and the keyboard could be used to generate any
appropriate reply messages from the user, thereby obviating need
for the reply buttons and allowing free form messages to be sent
by the mobile transceiver. A user selected reply would be
5 transferred to the mobile transceiver 1500 from the PC for
transmission to the base receiver.

Alternatively, the mobile transceiver could be connected to a
voice data replay device, such as a speaker, thereby allowing the
user to receive messages from a voice mailbox, for example. Of
10 course, a voice data generation device, such as a microphone,
could be connected to the mobile transceiver 1500 to allow the
user to reply to the voice mail message he has received or to
initiate voice data communication from the mobile transceiver to
the base receivers. Similarly, facsimile transmissions could be
15 supported.

An alternate embodiment of the mobile unit includes only
receive capabilities, but does not include any transmit
capabilities. Fig. 17 shows a mobile receiver 1700. The various
components of the mobile receiver generally correspond in
20 functionality to the similar elements shown in Fig. 15. Of
course, the mobile receiver 1700 cannot generate replies, which
includes user initiated replies, an autonomous acknowledgment
signals or negative acknowledgment signals, because of the lack of
transmit capability. Also, the location of this alternate
25 embodiment cannot be tracked by the network control center because
of the lack of transmit capability. Generally, because of these
reasons, the mobile receiver 1700 embodiment of the mobile unit is

LAW OFFICES
FINNEGAN, HENDERSON
FARABOW, GARRETT
& DUNNER
1200 I STREET, N.W.
WASHINGTON, DC 20005
1-202-408-4000

30

42 -

1 less preferable than the mobile transceiver embodiment 1500.
Further, it should be appreciated that the mobile transceiver
embodiment may include circuitry for generating various autonomous
responses without interaction by the user.

5 F. The Base Receiver

The base receivers of the present system receive the low
power output signal from the mobile transceiver unit. As is shown
in Fig. 6, mobile receivers are dispersed throughout the
geographic service area. Base receivers need not be associated
with zonal boundaries per se, but will always be located to
10 service at least one zone, of course. A few base receivers may
exist in the overlap region between zones.

During transmission of the return signal by the mobile
transceiver unit, it is possible that several base receivers could
15 receive this return signal. In this instance, the network
operations center 600 preferably selects the data from the base
receiver with the highest received signal strength (i.e. the
signal with the lowest probability of errors) to maximize the
likelihood of receiving accurate data. The signal strength
20 approach is preferred and can be satisfactorily implemented if the
base receiver locations are carefully selected to insure adequate
signal strength reception from the mobile transceiver units and to
minimize the overlap between base receiver coverage areas.
Alternately, the network operations center 600 could use "voting"
25 techniques by comparing each data set from the several base
receivers to arrive at the most likely return signal data using
conventional voting receiver technology.

LAW OFFICES
FINNEGAN, HENDERSON
FARABOW, GARRETT
& DUNNER
1300 I STREET, N.W.
WASHINGTON, D.C. 20005
1-202 408 4000

30

44-43 -

1 Fig. 18(A) shows a first embodiment of an analog base
receiver. Analog receiver 1802 is connected to an antenna 1800.
The analog receiver 1802 simply receives the signal from the
antenna 1800 and removes the modulated waveform from the carrier
5 frequency and outputs this waveform in analog format to a regional
demodulator 1804 via data path 1806. Data path 1806 is preferably
a 4 KHz analog telephone channel.

 The regional demodulator 1804 receives signals from several
analog receivers included in several base receivers. Preferably,
10 the regional demodulator 1804 is located in the regional station,
such as regional station 650 shown in Fig. 6. The demodulated
signal from the regional demodulator 1804 is then transferred to
the regional processing circuitry 1808, and then onto the network
operations center 600.

15 The analog receiver 1802 could generate identification data
to be transmitted with each received message so the network
operations center 600 can determine the source of each message
received. Alternatively, and preferably, dedicated communication
paths are used for each base receiver and therefore, the source of
20 the message can be inferred from the communication path that is
activated.

 Fig. 18(B) shows a digital base receiver embodiment which
includes an antenna 1800 attached to an analog receiver 1802. As
in the previously discussed embodiment, the analog receiver 1802
removes the modulated waveform from the carrier signal transmitted
25 by the mobile transceiver unit. The analog receiver 1802 outputs
the modulated waveform to a demodulator 1810 included in the base

LAW OFFICES
FINNEGAN, HENDERSON
FARABOW, GARRETT
& DUNNER
1300 I STREET N.W.
WASHINGTON, DC 20005
1-202-408-4000

30

48 - 44 -

1 receiver. The demodulator 1810 produces a digital output signal
corresponding to the data stream transmitted by the mobile
transceiver unit. The demodulator 1810 provides the digital
output signal to the regional processing circuitry 1808 in the
5 regional station via data path 1812. Data path 1812 may be any
conventional data path which can satisfactorily convey the digital
data from the demodulator 1810 to the regional processing center
1808. The regional processing circuitry 1808 then passes the data
to the network operations center 600.

10 Fig. 19 shows a digital base receiver including error
correction and store and forward features. An antenna 1900 is
connected to an analog receiver 1802 which is connected to a
demodulator 1810, as previously described with reference to
Fig. 18(B). The demodulated digital signal is output from
15 demodulator 1810 to error correction circuitry 1906 which may
perform error correction algorithms to insure the integrity of the
return signal received from the mobile transceiver unit. Of
course, the error correction circuitry should decode and correct
data which have been compatibly encoded by the mobile transceiver.

20 The error corrected data output from the error correction
circuitry 1906 is provided to a store and forward circuit 1908.
The store and forward circuit 1908 stores the received data to
allow it to be transmitted later at a convenient time and at a
convenient data transmission rate.

25 For example, in the present system it is likely that the
return signal traffic received by the base receiver will occur in
short bursts at a relatively high data transfer rate. However, it

LAW OFFICES
INNEGAN, HENDERSON
FARABOW, GARRETT
& DUNNER
1500 I STREET, N.W.
WASHINGTON, DC 20005
1-202-409-1000

30

46 - 45 -

1 is also likely that the average data transfer rate from the base
receivers is substantially lower than the instantaneous data
transfer rate during traffic bursts. The store and forward
circuit 1908 may preferably act as a buffer to allow the return
5 signal data to be communicated from the store and forward circuit
1908 to the regional processing circuitry 1808 at a lower (and
less expensive) data transfer rate. Store and forward circuit
1908 is, therefore, preferably connected to regional processing
circuitry 1808 via data path 1910 which may include a low cost
10 telephone line.

G. The Network Operations Center

1. Overview

The network operations center 600 is shown in schematic form
in Fig. 20. The network operations center 600 includes a base
15 receiver input system 2000 which receives data from the various
regional stations throughout the system (e.g., regional stations
644 and 650) via various data paths, such as data paths 656 and
658 as shown in Fig. 6. The data received by the base receiver
input system 2000 includes reply data from users with various
20 control data. Base receiver input system 2000 may include
appropriate conventional signal processing equipment. Control
data may include data identifying the base receiver (i.e. location
of the mobile unit) which received the associated reply.
Preferably, the base receiver input section 2000 receives data
25 from the regional stations via phone lines. However, other
appropriate data paths may be considered.

LAW OFFICES
FINNEGAN, HENDERSON
FARABOW, GARRETT
& DUNNER
1300 I STREET, N.W.
WASHINGTON, DC 20005
30-202 408-4000

47,46 -

1
5
10

The base receiver input system 2000 then provides the received data to a central computer 2002. The central computer 2002 may also receive input from a user input system 2004. For example, the user input system 2004 may receive data from users via phone lines who may access and interact with the central computer via voice, DTMF, or modem transmission and may include appropriate conventional signal processing equipment. A user may interact with the central computer 2002 to modify his service, to initiate or receive messages, or to perform other desirable functions.

15

Generally, the central computer 2002 processes the data received from the base receiver input system 2000 and from the user input system 2004 to perform various operations on the data, to update various database entries for use by the central computer 2002, and to generate data for transmission to a satellite uplink output system 2006.

20

It should be understood that, although Fig. 20 shows the central computer as existing at a single location in the network operations center 600, a distributed computing system may be used to perform the necessary functionality of the central computer 2002. Presently, however, a single location for the central computer 2002 is preferred.

25

Satellite uplink output system 2006 receives data from the central computer 2002 and provides it to satellite 606, shown in Fig. 6, for transmission to base transmitters within the system (e.g., base transmitters 612 and 614 in Fig. 6).

LAW OFFICES
FINNEGAN, HENDERSON
FARABOW, GARRETT
& DUNNER
1300 I STREET, N.W.
WASHINGTON, DC 20005
302 408 4000

1

The central computer 2002 is also connected to a database system 2008 which stores various data such as message data, user status data, system status data, and message status data, for example, for use by the central computer 2002 in processing.

5

Also, a control access 2010 is provided to allow systems engineers or programmers to access the central computer 2002 to observe and modify its operations and system performance.

2. Database Structure

10

The database 2008 of the network operations center includes several database structures necessary for the operation of the system. While a preferred partitioning of these databases is described below, it should be understood that other partitionings could be considered, such as moving the various "user traffic" fields from the traffic statistics database to the user database.

15

a. The User Database

20

For example, the user database structure shown in Fig. 21 includes a record for each user of the system who possesses a mobile unit. The record for user 1 2100 includes various fields, such as an ID number field 2102 which indicates a unique number associated with that particular user. The transmit capability field 2106 indicates whether the mobile unit assigned to the user has the capability to transmit. The last location field 2104 includes data which indicates the last known location of the user. The last location field may be updated when the central computer recognizes that a new base receiver has received a return signal from the mobile unit, thereby indicating the mobile unit has moved since the last return signal. Of course, if the mobile unit only

25

LAW OFFICES
FINNEGAN, HENDERSON
FARABOW, GARRETT
& DUNNER
1300 I STREET, N.W.
WASHINGTON, D.C. 20005
1 202 406 #000

30

1 includes a mobile receiver without transmit capability, the last
location field 2104 cannot be updated and the mobile unit may be
given a default location.

5 The service area field 2108 includes data corresponding to
the area in which the user has subscribed to. For example, if a
user desires service in geographic areas less than the total
system service area, the central computer could use the data in
the service area field 2108 to cause only selected base
transmitters to attempt to transmit messages to a mobile unit.

10 The button format field 2110 includes data indicating the
format of reply buttons the user may access on the mobile
transceiver. Of course, for mobile units with only receive
capabilities, the button format field will not be used.

15 The message field 2112 includes data representing one or more
messages which are intended for the user. A receive flag is set
when the central computer has received data indicating that the
message has been received by the mobile unit via an acknowledgment
signal. If the mobile unit does not have transmit capability, the
receive flag is set upon transmission of the message by the
20 appropriate base transmitters. The user database structure may
include other fields for each user of the communication system of
the present invention as needed to provide various desired
services.

b. The Receiver Database

25 Database 2008 of Fig. 20 includes a receiver database (not
shown) which includes an entry with several associated fields for
each base receiver in the system. A first field for each base

LAW OFFICES
FINNEGAN, HENDERSON
PARABOW, GARRETT
& DUNNER
1300 I STREET N.W.
WASHINGTON, DC 20005
1-202-408-4000

30

75 - 49 -

1 receiver preferably includes the total number of mobile units
which have last communicated with this receiver. A second field
for each base receiver preferably includes a list of base
transmitters which may cover all or a portion of the receiver
5 coverage area of that base receiver.

c. Traffic Statistics Database

Database 2008 of Fig. 20 should also include preferably a
traffic statistics database as shown in Fig. 22 which includes
various fields containing statistics calculated by the central
computer 2002 concerning traffic patterns for the system. For
10 example, the traffic database 2200 preferably includes a user
field 2202 for data indicating a user of the network. Several
fields are preferably associated with the user field 2202. Field
2204 includes data representing the number of probe signals sent
15 by the network to locate the mobile unit associated with the user
field 2202. Field 2206 includes data representing the number of
registration signals received by the network from the mobile unit
associated with the user field 2202. Field 2208 includes data
representing the number of messages from the network that have
20 been successfully delivered to the mobile unit associated with the
user field 2202. Field 2210 may be used for other traffic related
data, such as data indicating the average traffic per cycle, and
data indicating a time average (i.e. for the last hour) traffic
amount.

25 Further, the traffic database 2200 could include fields (not
shown) for data concerning overall system performance and, in
particular, each zone in the network. Such area specific traffic

LAW OFFICES
FINNEGAN, HENDERSON
FARABOW, GARRETT
& DUNNER
1000 I STREET, N.W.
WASHINGTON, D.C. 20005
1-202-408-4000

30

50 -

1 data may be useful in optimizing system performance by allowing
intelligent redefinition of zonal boundaries.

d. The Service Queue

5 Database 2008 of Fig. 20 also includes a service queue 2300
as shown in Fig. 20. The service queue 2300 includes a current
messages queue and a probe list queue. The current messages queue
includes a system wide list of messages to be delivered by the
system. The current messages queue includes, for example, a
series of ID number fields 2302, 2304, and 2306 with associated
10 data location fields 2308, 2310, and 2312, respectively. The data
location fields 2308, 2310, and 2312 include pointers to the
appropriate fields in the user database structure shown in
Fig. 21. The ID number fields 2302, 2304, and 2306 include data
indicating the ID number of the user to which the message is to be
15 delivered.

In operation, the central computer retrieves the ID number
2302 and data location 2308 from the top of the current messages
queue and retrieves the appropriate data from the user database
2100 to process and transmit a message to the user.

20 The probe list queue includes a ID number fields 2314, 2316,
and 2318 and data location fields 2320, 2322, and 2324 similar in
form to those in the current messages queue. The probe list queue
contains a list of users which the system has previously attempted
unsuccessfully to deliver a message to. In other words, the users
25 listed in the probe list are considered to be "lost" by the
system. The central computer 2002 then initiates a probe routine

LAW OFFICES
FINNEGAN, HENDERSON
FARABOW, GARRETT
& DUNNER
1300 I STREET, N.W.
WASHINGTON, DC 20005
30-202-408-4000

51 -

1 for the ID number 2314 and data location 2320 located at the top
of the probe list.

5 After successful execution of the probe routine, the last
location field 2304 in the user database structure 2100 will have
been updated to provide an accurate last location of the user from
the base receiver that received the mobile unit's acknowledgment
to the probe signal. After the last location field 2304 has been
updated, the message can then be replaced in the current messages
queue for delivery to the user via the appropriate base
10 transmitters located near the mobile unit.

15 Preferably, the network operations center gives priority to
the delivery of all messages in the current message queue, and
then sends probe signals to the users listed in the probe list
queue after delivery has been attempted for all messages in the
current message queue. If the message volume in the current
message queue remains high for an extended period of time, the
network operations center preferably begins to periodically send
probe signals to the users listed in the Probe List, even though
undelivered messages remain in the current messages queue. For
20 example, in this instance of persistent filled current messages
queue, the network operation center preferably transmits three
probe signals in every cycle transmitted.

e. Base Transmitter Assignment List

25 The database 2008 of the network operations center also
includes a base transmitter database 2400 as shown in Fig. 24.
The base transmitter database 2400 includes a zonal assignment
field 2404 for data representing a zone assignment associated with

LAW OFFICES
FINNEGAN, HENDERSON
FARABOW, GARRETT
& DUNNER
1300 I STREET N.W.
WASHINGTON, DC 20005
TEL: 202 426-4000

30

52 -

1 a base transmitter field 2402 in the system. Also, a field 2406
for data representing the base receivers in the transmitter
coverage area, and a field 2408 for other data associated with a
base transmitter, are associated with base transmitter field 2402.
5 As can be seen in Fig. 24, each base transmitter in the network
has a base transmitter field and associated fields as described
above.

In normal operating conditions of the system with low amounts
of message traffic being transmitted, each base transmitter will
10 remain assigned to its particular zone. However, the systems and
methods of the present invention provide for dynamically changing
the zonal assignments of various base transmitters to improve
information throughput. These dynamic zone allocation concepts
dynamically reassign base transmitters to new zones generally
15 based upon the volume of messages transmitted during the
systemwide time interval, and more particularly based upon the
localized volume of messages to mobile units. In general, dynamic
zone allocation may be used to deliver messages to mobile units in
overlap areas (i.e. "zonal dithering"), or to balance the volume
20 of message traffic between zones.

Fig. 25 is useful to explain these concepts. Various base
transmitters, each designated as an "X," are dispersed throughout
a region of space shown in Fig. 25. Also, various base receivers
are dispersed throughout this region of space 2500, each being
25 designated by an "R." The normal zonal boundary for zone 1 in
Fig. 25 is shown by solid line 2502. A normal boundary for zone 2
is represented by solid line 2504 during normal load traffic

LAW OFFICES
FINNEGAN, HENDERSON
FARABOW, GARRETT
& DUNNER
1300 I STREET, N.W.
WASHINGTON, DC 20005
1-202-402-4000

30

57- 53 -

1 operation conditions. As can be seen, base transmitters 2506,
2508, and 2510 are located near the zonal boundary of zone 2, and
base transmitters 2512, 2514, and 2516 are located near the
boundary of zone 1. Base receivers 2518 and 2520 are located in
5 an overlap area 2521 between zones 1 and 2. As previously
discussed, mobile units located in this overlap area 2521 near
base receivers 2518 and 2520 must be communicated with during the
systemwide time interval because of the interference created
during the zonal time interval by adjacent base transmitters.

10 During normal, low to moderate volume system operations, the
zonal overlap area 2521, i.e., interference area, near base
receivers 2518 and 2520 will preferably have a small number of
mobile units located therein. Therefore, communication with these
mobile units will not significantly consume system resources by
15 occasionally communicating with them during the systemwide time
interval.

However, if the traffic volume from the overlap area 2521
near base receivers 2518 and 2520 increases, such as because
additional mobile units enter this overlap area 2521, the handling
20 of this traffic in the systemwide time interval can significantly
consume system resources. For example, communication with a large
number of mobile units during the systemwide time interval may
significantly delay delivery of messages to units in this and
other regions.

25 In this instance, the zonal boundaries are changed to remove
this high traffic region from a zonal overlap area. For example,
system efficiency is restored if the zone 1 boundary were moved to

LAW OFFICES
FINNEGAN, HENDERSON
FARABOW, GARRETT
& DUNNER
1300 I STREET N.W.
WASHINGTON, DC 20005
1-202 408-4000

30

58 - 54 -

1 dashed line 2522 and the zone 2 boundary were moved to dashed line
2524.

5 The central computer 2002 may dynamically accomplish this
zonal redefinition by assigning one or more base transmitters to a
new zone to reduce systemwide time interval messages. In the
10 present example shown in Fig. 25, the central computer updates the
base transmitter zonal assignment list to reassign base
transmitters 2512, 2514, and 2516 to zone 2 while removing these
base transmitters from zone 1. In view of this zonal
15 redefinition, the new zone 1 boundary is shown by dashed line
2522, and the new zone 2 boundary is shown by dashed line 2524.
The high traffic region near base receivers 2518 and 2520 is now
squarely within zone 2 and messages to these units may be
efficiently delivered during subsequent zonal time interval(s).

20 In accordance with the invention, a preferred method 2600 for
accomplishing zonal redefinition is shown in Fig. 26. In
accordance with the method, step 2602 provides for transmitting
substantially simultaneously a first information signal and a
second information signal, the first information signal being
25 transmitted in simulcast by a first set of base transmitters
assigned to a first zone, and the second information signal being
transmitted in simulcast by a second set of base transmitters
assigned to a second zone. For example, as shown in Fig. 25, the
base transmitters in zone 1 defined by boundary line 2502 could be
the first set of base transmitters, and the base transmitters
30 located in zone 2 defined by boundary line 2504 could be the
second set of base transmitters.

LAW OFFICES
FINNEGAN, HENDERSON
FARABOW, GARRETT
& DUNNER
1300 I STREET, N. W.
WASHINGTON, D. C. 20005
1-202-408-4000

30

56-55-

1 Step 2604 of the method provides for dynamically reassigning
one or more of the base transmitters in the first set of base
transmitters assigned to the first zone to the second set of base
transmitters assigned to the second zone, thereby creating an
5 updated first set of base transmitters and an updated second set
of base transmitters. For example, base transmitters 2512, 2514,
and 2516 could be reassigned from zone 1 to zone 2. As shown in
Fig. 25, new zonal boundaries would be defined by dashed lines
2512 for zone 1 and 2524 for zone 2.

10 Step 2606 provides transmitting substantially simultaneously
a third information signal and a fourth information signal, the
third information signal being transmitted in simulcast by the
updated first set of base transmitters and the fourth information
signal being transmitted in simulcast by the updated second set of
15 base transmitters. For example, as shown in Fig. 25, the base
transmitters assigned to zone 1 defined by dashed line 2522 (i.e.
not including base transmitters 2512, 2514, and 2516) could
transmit during a subsequent communication cycle a third
information signal, and base transmitters in zone 2 defined by
20 dashed line 2524 (i.e. including base transmitters 2512, 2514, and
2516) could transmit a fourth information signal during that same
subsequent communication cycle.

 Further, it is desirable that during the redefinition of the
zonal boundaries, it is insured that the new overlap area 2525
25 near base receiver 2526 and between dashed lines 2522 and 2524 is
an area that is not likely to produce, or is not currently
producing a high volume of message traffic. Generally, zonal

LAW OFFICES
FINNEGAN, HENDERSON
FARABOW, GARRETT
& DUNNER
1300 I STREET, N.W.
WASHINGTON, D.C. 20005
1-202-462-4000

30

87 } 56 -

1 boundaries should be preferably redefined to maximize information
throughput by minimizing the data that must be transferred during
the systemwide time interval. A network manager could review the
overall traffic patterns and tendencies to determine an optimum
5 redefinition of zonal boundaries. Of course, the central computer
2002 could also implement an algorithm accessing the traffic
statistics database 2200 to determine optimal zonal boundary
redefinition.

10 In a preferred embodiment in the instance where an entire
region is saturated with mobile units, such as a large
metropolitan area repetitive reassignments of base transmitters
may be used to reduce message traffics during the systemwide time
interval. There may exist no appropriate overlap area, such as
overlap area 2525, with a low traffic level to facilitate a long
15 term reassignment of base transmitters with the resulting
redefinition of zonal boundaries. In this case, the preferred
embodiment alternates between a first and second set of zonal
boundaries over each communication cycle and does not attempt to
deliver messages during the systemwide time interval.

20 For example, in Fig. 25 this preferred embodiment would
utilize the zonal boundaries defined by lines 2502 and 2504 during
a first zonal time interval and would not attempt to deliver
messages to mobile units in overlap area 2521. In a subsequent
cycle, this preferred embodiment redefines the zonal boundaries to
25 dashed lines 2522 and 2524 and delivers messages to the mobile
units in previous overlap area 2521 during the zonal time interval
using zone 2 base transmitters. During this cycle, the network

LAW OFFICES
FINNEGAN, HENDERSON
FARABOW, GARRETT
& DUNNER
1300 I STREET, N.W.
WASHINGTON, DC 20005
(202) 408-4000

30

55 - 57 -

1 would not attempt to deliver messages to mobile units in overlap
area 2525. In yet a later cycle, this preferred embodiment would
switch back to zonal boundaries 2502 and 2504 which would allow
message delivery to mobile units in the now previous overlap area
5 2525 during the zonal time interval using zone 1 base
transmitters. As can be seen, alternating between a first and
second set of zonal boundaries advantageously reduces the need for
communication during the systemwide time interval, but slows
message delivery somewhat by only allowing communication to mobile
10 units in overlap areas during zonal time intervals on alternating
communication cycles.

H. The Preferred System Communication Protocol

The system communication protocol is preferably a time
division protocol organized within repetitive communication cycles
15 of preferably 30 seconds in duration.

The blocks of data transmitted by the network are preferably
formed by a bit interleaving process to prevent loss of data
during bursts of interference. Bit interleaving may be envisioned
as stacking two or more blocks of data (which read from left to
20 right), and then transmitting a bit stream in a column-by-column,
top-to-bottom sequence. As can be seen, a burst of interference
will likely only cause the loss of a few bits per word at most,
which can be corrected by error correction techniques, rather than
the loss of entire words. Of course, the mobile unit must
25 appropriately deinterleave the data prior to processing.

LAW OFFICES
FINNEGAN, HENDERSON
FARABOW, GARRETT
& DUNNER
300 I STREET, N.W.
WASHINGTON, D.C. 20005
1-202-408-4000

1 Fig. 27 generally illustrates a variety of preferred time
intervals which may variously be used for communication between
the system and various sets and subsets of mobile units. An
adaptable schedule for these time intervals is preferably
5 generated, and may be revised according to system demands. The
scheduling of the time intervals advantageously allows a mobile
unit to "power down" during inactive time periods when the mobile
unit will not transmit or receive any messages, thereby conserving
battery power. Similarly, messages or information for delivery to
10 a subset of the total number of mobile units will preferably be
transmitted during time intervals which minimize the delivery of
those messages or information to unintended mobile units not
included in the subset to further conserve battery power.

A preferred cycle protocol 2700 is shown in Figure 27(A).
15 The cycle protocol 2700 includes a cycle header time interval
2702, a systemwide forward (FWD) batch time interval 2704, a
systemwide response time interval 2706, a zonal forward (FWD)
batch time interval 2708, a zonal reverse time interval 2710, and
a reverse contention time interval 2712. Other arrangements, such
20 as moving the systemwide reverse interval next to the zonal
reverse interval may be considered if transmitter turn on time is
significant.

The cycle protocol generally schedules time slots for
systemwide and zonal forward channel information transfer from the
25 network to the mobile units and for systemwide and zonal reverse
channel information transfer from the mobile transceiver units to
the network. Briefly, the cycle header 2702 field includes

LAW OFFICES
FINNEGAN, HENDERSON
FARABOW, GARRETT
& DUNNER
1300 L STREET, N.W.
WASHINGTON, D.C. 20005
(202) 408-4000

30

(C) - 59 -

1 overhead or "housekeeping" information, the systemwide forward
batch field 2704 and the zonal forward batch field 2708 provide
forward communication capability through the base transmitters to
the mobile units in a systemwide time interval and a zonal time
5 interval, respectively. The systemwide response field 2706 and
zonal reverse field 2710 provide a return signal period for the
mobile transceivers to respond to messages generated during the
systemwide and zonal forward batch periods 2504 and 2508,
respectively. Finally, the reverse contention 2712 field allows
10 the mobile transceiver to initiate access to the network.

Each of the fields shown, except the cycle header 2702 field,
is preferably variable in duration, and may be changed by the
central computer 2002, depending on message traffic requirements.
The beginning of the cycle is synchronized by the central computer
15 to a time standard and preferably coincides with the start of
minute or half minute intervals. Each mobile unit preferably
includes timing circuitry, as previously described, which allows
for the mobile unit to power up at the beginning of each cycle to
receive communication.

20 For each cycle, the central computer 2002 calculates the
amount of time required for each field to maximize information
throughput by the network. For example, for the cycle protocol
2700 shown in Fig. 27(A), the central computer will calculate the
amount of time necessary for the systemwide forward batch field
25 2704, the systemwide response interval 2706, the zonal forward
interval 2708, the zonal reverse interval 2710, and the reverse
contention interval 2712. The cycle header 2702 will preferably

LAW OFFICES
FINNEGAN, HENDERSON
FARABOW, GARRETT
& DUNNER
1320 I STREET N.W.
WASHINGTON, D.C. 20005
1-202-406-4000

30

(c) - 60 -

1 include timing offset data which will indicate the timing offset
from the cycle header until the beginning of the systemwide
response interval 2706, the beginning of the zonal forward
interval 2708, the beginning of the zonal reverse interval 2710,
5 and the beginning of the reverse contention interval 2712.

The cycle header 2702 starts preferably with an 8 digit long
preamble (not shown) for digit synchronization purposes. The
preamble allows for the mobile unit to synchronize its timing
circuitry with the network. For example, the timing circuitry of
10 the mobile unit could become offset from the network due to
commonly caused inaccuracies. The preamble is followed by a
"start of header" string of four digits and all timing offsets
within the cycle are calculated as a number of predefined
intervals beginning from the start of the last header digit. The
15 start of header string is followed by an 8 digit string grouped
into two words, each of which is protected against errors by
encoding it using a forward error correcting code, preferably a
Bose, Chaudhuri, and Hocquenghem (BCH) code or a Reed Solomon
code. These error correcting codes add additional digits to the
20 information digits in a code word, where the additional digits are
a specific function of the information digits, so that if certain
common error events occur, a decoding step involving all of the
transmitted digits, both information and additional, can recover
the original information digits. The first code word will contain
25 a count of the current cycles executed for that day. The second
code word will contain the necessary timing offsets for the
beginning of the time intervals in the cycle protocol 2700.

LAW OFFICES
FINNEGAN, HENDERSON
FARABOW, GARRETT
& DUNNER
1300 I STREET, N.W.
WASHINGTON, DC 20005
1-202-408-4000

30

(61) - 61 -

1 Further information regarding error correcting codes may be found
in Gallagher, "Information Theory and Reliable Communication,"
Wiley 1968, which is hereby incorporated by reference.

5 The systemwide forward batch 2704 field generally includes a
zonal header time interval including overhead information and a
series of 64 batches. Also, the zonal forward interval 2710
similarly includes a zonal header time interval with overhead
information and a series of 64 batches. Each batch is a string of
10 data containing information specifically directed to a single
group of mobile units. Each batch preferably contains information
directed to a certain class of mobile units with the classes
divided by the types of service provided. For example, a first
batch could be directed to all mobile transceiver units, and a
second batch could be directed to all mobile receiver units.
15 Further, each batch may contain several messages, each intended
for different mobile units within the particular class of unit to
which that batch is directed. Generally, Fig. 27(B) shows the
forward batch interval protocol 2750 preferred for both the
systemwide forward interval 2704 and the zonal forward interval
20 2708.

The systemwide forward interval 2704 is preferably used only
for sending a probe signal to a mobile transceiver unit which does
not respond to zonal messages (i.e. a "lost" unit). However, when
necessary, the systemwide forward interval 2704 may be used to
25 deliver messages to mobile units located in overlap areas. The ID
number, or address, of the lost mobile unit is preferably followed
by data indicating a timing offset which is a time delay amount

LAW OFFICES
FINNEGAN, HENDERSON
FARABOW, GARRETT
& DUNN
1300 I STREET, N.W.
WASHINGTON, DC 20005
1-202-408-4000

30

63-62-

1 until the beginning of the time slot designated for the return
signal of that mobile unit. An alternative implementation, which
may be useful for mobile units that have not responded for a
period of time, could have mobile units that have received a probe
5 signal respond during the reverse contention interval.

After the end of the broadcast on the systemwide forward
batch time interval 2704, all network base transmitters shut down
until the beginning of the zonal forward batch time interval 2708.

10 The forward batch interval protocol 2750 includes a forward
channel header interval 2714 which includes data to allow the
timing circuitry of the mobile units to synchronize themselves
with the incoming data stream. The forward channel header 2714
also preferably includes data indicating a timing offset
scheduling a reverse channel time interval for each batch, as may
15 be required. Of course, the forward channel header 2714 for the
systemwide forward interval 2704 would indicate a timing offset
for reverse channel transmission during the systemwide response
interval 2706, and the forward channel header 2714 for the zonal
forward interval 2708 would indicate a timing offset for reverse
20 channel transmission during the zonal reverse interval 2710.

The forward channel header 2714 further includes a data
stream to the mobile unit listing which of the 64 batches will
follow and the timing offsets indicating when those batches will
be transmitted. Again, this feature advantageously allows the
mobile unit to "power down" during the systemwide and zonal
25 forward intervals 2704 and 2708 until the appropriate time for
receiving its batch information, thereby conserving the battery

LAW OFFICES
FINNEGAN, HENDERSON
FARABOW, GARRETT
& DUNNER
1300 I STREET N.W.
WASHINGTON, DC 20005
1-202-408-4000

30

(d) - 63 -

1 power of the mobile unit. The remaining fields batch i 2720,
batch j 2722, and batch k 2724 are the individual batches directed
to the mobile units.

5 It should be understood that different classes of mobile
units can follow different desirable batch protocols, depending on
the type of service, processing power, battery capacity, or other
factors.

The individual batch protocol 2780 is shown in Fig. 27(C).
The batch header field 2726 is similar to the header fields
10 discussed above for Figs. 27(A) and (B). The batch header 2726
includes a list of particular mobile units to receive messages
within the batch and includes timing offsets indicating when such
messages will be broadcast. Further, the batch header 2726
includes data indicating a timing offset scheduling a reverse
15 channel interval in the system reverse interval, the zonal reverse
interval, or the reverse contention interval, as appropriate.
Again, this information allows the mobile unit to extend its
battery life because the mobile unit need only power up at the
appropriate time to receive or transmit the appropriate message.
20 Further, it is preferred that the reverse channel timing offset
data be transmitted using error correction codes to insure
accurate receipt thereof by the mobile unit. Accurate receipt of
the reverse channel timing offset data will prevent unwanted or
untimely transmissions by the mobile unit and insure that a mobile
25 unit may properly transmit a negative acknowledgment signal if it
fails to properly receive an unencoded message.

LAW OFFICES
FINNEGAN, HENDERSON
FARABOW, GARRETT
& DUNNER
1300 I STREET, N.W.
WASHINGTON, DC 20005
30-202 408-4000

1 The individual message interval 2732 includes the individual
message intended for a particular mobile unit or units. The
duration of each message and number of messages within a batch may
be varied by the network operations center 600 and is traffic
5 dependent.

Each mobile unit with transmit capability that has received a
message in the immediately previous systemwide forward interval
2704 or the zonal forward interval 2708 will have an appropriate
time slot for transmission scheduled in the systemwide response
10 interval 2706, or the zonal reverse interval 2710, respectively.
The timing circuit in the mobile transceiver unit determines the
assigned time slot for transmission. For example, if the mobile
unit simply intends to transmit an acknowledgment signal, which
indicates that the mobile unit has properly received the message
15 from the network, an 8 bit preamble followed by the address of
that mobile unit need only be transmitted and a 3 bit
acknowledgment. However, if a more extensive reply from the
mobile unit is required, additional data could be transferred
during this time slot. In particular, long reverse messages could
20 be scheduled in response to a request from the mobile unit sent
during the contention interval 2712, as discussed hereafter.

Due to the low power transmit capability of the mobile
transceiver units, there is an increased likelihood of data
transmission errors for reply signals. The extended Golay code
25 for error protection may be utilized for reverse channel messages
from mobile transceiver units to the network.

LAW OFFICES
FINNEGAN, HENDERSON
FARABOW, GARRETT
& DUNNER
1300 I STREET, N.W.
WASHINGTON, D.C. 20005
30-202 408-4000

W.C. - 65 -

1 The systemwide response interval 2706 and the zonal reverse
interval 2710 provide communication capability from the mobile
transceiver units to the network (i.e. the reverse channel).

5 Still further, a preferred embodiment accommodates mobile
terminals with extensive reverse message generation capabilities
(e.g., a laptop computer connected to a radio transceiver) by
allowing for contention messages that request extended reverse
channel time for the transmission of a long reverse message. The
reverse contention interval 2712 is located after the zonal
10 reverse interval 2710 and provides for unscheduled messages from
the mobile unit to the network. For example, the mobile
transceiver unit could send a message to the network during the
reverse contention interval 2712 indicating that the user no
longer wishes to receive messages, thereby terminating service.
15 Also, the user could transmit a message to the network during the
reverse contention interval 2712 indicating that the user now
desires to reestablish services and begin receiving messages from
the network. Further, a "registration signal," which is discussed
infra, could be transmitted during the reverse contention interval
20 2712.

25 The reverse contention interval preferably utilizes a
so-called "slotted ALOHA" protocol, which allows the mobile unit
to randomly select a predefined time slot within the contention
interval to transmit a message. A mobile station wanting to
transmit will first divide the contention interval into slots,
preferably 5.33 ms in length, and then choose randomly any of them
to start transmitting. The slotted ALOHA protocol is preferred

LAW OFFICES
FINNEGAN, HENDERSON
PARBOW, GARRETT
& DUNNER
1300 I STREET, N.W.
WASHINGTON, DC 20005
1-202-408-4000

30

66 -

1 because of the low likelihood of data "collisions" (i.e. 2 or more
mobile units transmitting during the same time slot).

I. Registration of the Mobile Unit

5 Because the network operations center 600 stores the location
of each mobile unit in the system in the user database 2100, it is
preferred that each mobile transceiver unit have the capability to
"register" with the network operations center 600 by sending a
registration signal to a base receiver into the network to update
the location data.

10 The mobile transceiver unit preferably registers by simply
transmitting its identification number to a base receiver, which
forwards this data and data representing the location of the base
receiver to the network operations center 600.

15 The mobile transceiver preferably registers upon crossing
zonal boundaries to alert the network operation center that the
mobile transceiver has left one zone and entered another. For
example, the mobile unit could receive information from the
nearest base transmitter identifying which zone that base
transmitter is assigned to at the beginning of each communication
20 cycle. Upon receipt of such information from a base transmitter
indicating that a nearby base transmitter is assigned to a new
zone, the mobile transceiver then preferably transmits a
registration signal.

25 The mobile transceiver unit may also transmit a registration
signal in other desirable instances. For example, if the mobile
transceiver unit has moved away from the transmitter coverage
areas of the network for a period of time, the mobile transceiver

LAW OFFICES
FINNEGAN, HENDERSON
FARABOW, GARRETT
& DUNNER
1300 I STREET, N.W.
WASHINGTON, DC 20005
1 202 409 4000

30

(6) - 67 -

1 unit may preferably transmit a registration signal upon returning
to a coverage area. The display and storage logic 1508 of the
mobile transceiver unit preferably recognizes that the unit has
left the coverage area of the network upon failure to receive data
5 from a base transmitter in the network during the cycle header
time interval 2702, for example. The mobile unit may leave the
coverage area of a base transmitter of the network when the user
takes the unit out of the country, or enters the basement of a
building, for example.

10 The mobile unit may also preferably transmit a registration
signal when power is restored to the mobile unit after having
power removed, such as after being turned off by the user. Of
course, the power may be restored to the unit by replacing or
recharging a dead battery, which may also cause transmission of a
15 registration signal.

In general, the network must balance the need for frequent
registrations by the mobile transceiver units, and the desirable
result of accurately knowing the location of each mobile unit,
thereby preventing the need for probe signals, with the
20 undesirable overhead costs of too frequent registration, which
sacrifices data throughput by utilizing valuable transmit time.

In the preferred embodiment, the central computer 2002 of the
network operations center 600 can achieve desirable performance by
implementing one or more algorithms to evaluate the need for
25 registration by a mobile unit, and then appropriately controlling
the registration performance of that mobile unit. If the central
computer determines that registration of a particular mobile unit

LAW OFFICES
FINNEGAN, HENDERSON
FARABOW, GARRETT
& DUNNER
1300 I STREET, N.W.
WASHINGTON, DC 20005
1-202-462-4000

30

68 -

1 is useful, then the mobile unit preferably should receive a
message from the network to cause the mobile unit to send
registration signals at appropriate times. Conversely, if the
central computer determines that the registration signals from the
5 mobile unit are too frequently not useful, the mobile unit
preferably should receive a message from the network to cause the
mobile unit not to transmit registration signals.

To implement this feature, the mobile transceiver unit
further preferably includes a registration flag (not shown) in the
display and storage logic section 1508. If the registration flag
10 is set, the display and storage logic section 1508 causes the
mobile transceiver to autonomously send a registration signal to
the network operations center on a desired basis. If the
registration flag is not set, the display and storage logic
15 section 1508 prevents any registration signals from being sent.
The registration flag may be set or removed upon command from the
network operations center by transmission of an appropriate signal
from a base transmitter near the mobile unit. A variety of
algorithms, possibly regarding individual users or groups of
20 users, can be used to determine whether or not the registration
flag should be set. It should be appreciated that the present
invention provides two distinct algorithms for implementing these
registration concepts depending upon whether the registration flag
is set or not in the mobile unit (i.e. the state of the mobile
25 unit).

LAW OFFICES
FINNEGAN, HENDERSON
FARABOW, GARRETT
& DUNNER
300 1 STREET, N.W.
WASHINGTON, DC 20005
1-202-408-4000

1

Fig. 28(A) shows a flow chart describing a preferred method 2800 for implementing the registration concepts of the present invention wherein the registration feature of the mobile unit is disabled. In step 2802, the network sends a message to disable the registration feature (i.e. set the registration flag to zero) of the mobile unit to disable the mobile transceiver's capability to transmit a registration signal. As can be seen, step 2802 determines the initial state for the method set forth in Fig. 28(A).

5

10

In step 2804, the network stores the number of probe signals sent to the mobile transceiver during a first period of time, and the number of messages successfully delivered to the mobile transceiver by the network during a second period of time. Preferably, the first and second time intervals are identical. The traffic statistics database 2200 of the database 2008 is preferably used to store the number of probe signals and successful messages for each mobile unit. As explained hereinafter, these two statistics from the operation of the network are preferably used to determine whether registration by the mobile unit is useful.

15

20

25

In step 2806, the stored number of probe signals and number of messages successfully delivered is processed to evaluate a likelihood that a probe signal will be required to be set by the network to locate the mobile unit to deliver a message. The preferred embodiment of the invention processes the stored number of probe signals and messages successfully delivered in accordance with the method set forth in Fig. 29(A).

LAW OFFICES
 FINNEGAN, HENDERSON
 FARABOW, GARRETT
 & DUNNER
 1300 I STREET, N.W.
 WASHINGTON, DC 20005
 1-202-406-4300

30

77 70 -

1 Referring now to Fig. 29(A), therein is shown a series of
substeps which are preferably performed during the implementation
of the processing step 2804 shown in Fig. 28(A). In particular,
steps 2902 and 2904 are event driven and only proceed to the next
5 step after an input has been received by the network. Step 2902
determines if the network sent a probe signal to a lost mobile
transceiver unit and if a reply to the probe signal was received
by a base receiver in the network. If this event occurs, a
counter (not shown) is incremented by a value P by the central
10 computer 2002.

In step 2904, if a message was successfully delivered to a
mobile transceiver, preferably including an acknowledgment signal
return from the mobile transceiver to the network, the counter
(not shown) in the central computer 2002 is decremented by a value
15 D.

After the occurrence of either of the events tested for in
step 2902 or step 2904, the algorithm proceeds to step 2906. In
step 2906, if the counter value is greater than a predetermined
value J, this indicates that the likelihood that a probe signal
20 will be necessary to locate the mobile transceiver is greater than
a selected value.

As can be seen, the process of substeps in Fig. 29(A)
balances the frequency of probe signals sent to a particular unit
against the number of successfully delivered messages to that
25 unit. If the system must send a large number of probe signals, it
would be useful to enable the registration feature by setting the
registration flag on that mobile unit to enable the registration

LAW OFFICES
FINNEGAN, HENDERSON
FARABOW, GARRETT
& DUNNER
1300 I STREET, N.W.
WASHINGTON, DC 20005
1-202-408-4000

30

- 71 -

1 feature. In contrast, if many messages have been successfully
delivered without requiring a probe signal, it is unnecessary to
enable the registration feature by setting the registration flag.

5 In step 2808, a message is sent to the mobile unit to enable
the mobile transceiver's capability to transmit a registration
signal if the calculated likelihood in step 2804 exceeds a
selected value. As can be seen, step 2808 preferably sets the
registration flag in the mobile transceiver unit.

10 Fig. 28(B) shows a flow chart describing a method 2810 for
implementing the registration concepts of the present invention
wherein the registration feature of the mobile unit is enabled.
In step 2812, the network sends a message to enable the
registration feature (i.e. set the registration flag to 1) of the
mobile unit to enable the mobile transceiver's capability to
15 transmit a registration signal. As can be seen, step 2812
determines the initial state for the method set forth in Fig.
28(B).

20 In step 2814, the network stores the number of registration
signals received by the network during a first period of time, and
the number of messages successfully delivered to the mobile
transceiver by the network during a second period of time.
Preferably, the first and second time intervals are identical.
The traffic statistics database 2200 of the database 2008 is
preferably used to store the number of registration signals and
25 successful messages for each mobile unit. As explained
hereinafter, these two statistics from the operation of the

LAW OFFICES
FINNEGAN, HENDERSON
FARABOW, GARRETT
& DUNNER
1000 I STREET, N.W.
WASHINGTON, DC 20005
30 202 405-4000

7.5 72 -

1 network are preferably used to determine whether the registration
by the mobile unit is useful.

5 In step 2816, the stored number of registration signals and
number of messages successfully delivered is processed to evaluate
the likelihood that a registration signal will be received by a
base receiver in the network that will not be used by the network
to determine a set of base transmitters to be operated to transmit
a message to the mobile transceiver. The preferred embodiment of
the invention processes the stored number of registration signals
10 received and number of messages successfully delivered in
accordance with the method set forth in Fig. 29(B).

Referring now to Fig. 29(B), therein is shown a series of
substeps which are preferably performed during the implementation
of the processing step 2814 shown in Fig. 28(B). In particular,
15 steps 2912 and 2914 are event driven and only proceed to the next
step after an input has been received by the network. Step 2912
determines if a registration signal was received by a base
receiver in the network. If so, a counter (not shown) in the
central computer 2002 is incremented by a value A.

20 In step 2914, if a message was successfully delivered to a
mobile transceiver, preferably including an acknowledgment signal
return from the mobile transceiver to the system, the counter (not
shown) in the central computer 2002 is decremented by a value M.

25 It should be understood that the counter referred to with
regard to steps 2912 and 2914 is different than the counter
referred to with regard to steps 2902 and 2904 since each counter
is only necessary when the registration feature is enabled or

LAW OFFICES
FINNEGAN, HENDERSON
FARABOW, GARRETT
& DUNNER
1300 I STREET N.W.
WASHINGTON, D.C. 20005
(202) 463-4000

30

- 73 -

1 disabled in the mobile transceiver. However, the same physical or
logical device may be used to implement both counters.

5 After the occurrence of either events in the step 2912 or
step 2914, the algorithm proceeds to step 2916. In step 2916, the
process determines if the counter value is greater than a
predetermined value T. The value of T can be varied to meet the
needs of a particular network. When the counter value exceeds T,
it is indicated that the likelihood that a registration signal
from that mobile unit will not be used by the network to determine
10 a new set of base transmitters, and therefore the registration
status for that mobile unit needs to be changed to disable the
registration feature.

15 In other words, the process in Fig. 29(B) balances the
frequency of registration signals sent by a particular unit
against the number of successfully delivered messages to that
unit. As can be seen, if the mobile unit sends a large number of
registration signals without the system using these registration
signals, it would be useful to have the registration feature on
that mobile unit disabled. In contrast, if many messages have
20 been successfully delivered without too many registration signals
being sent by the mobile unit, it is unnecessary for the
registration feature to be disabled.

25 In step 2818, a message is sent to the mobile unit to disable
the mobile transceiver's capability to transmit a registration
signal if the calculated likelihood in step 2814 exceeds a
selected value. As can be seen, step 2818 may preferably remove
the registration flag in the mobile transceiver unit.

LAW OFFICES
FINNEGAN, HENDERSON
FARABOW, GARRETT
& DUNNER
1300 I STREET, N.W.
WASHINGTON, DC 20005
1-202-462-4000

30

75-74-

1 Of course, it should be understood that the variables P, D,
and J used in Fig. 29(A), and the variables A, M, and T used in
Fig. 29(B) can be adjusted as desired to enhance system
performance, as will be apparent to one of ordinary skill in the
5 art. The counters can be implemented with so-called "reflective
boundaries" so that if a counter reaches a minimum value (e.g.,
zero), it will continuously reset to that minimum value when
further decremented.

10 It will be apparent to those skilled in the art that various
modifications and variations can be made in the systems and
methods of the present invention without departing from the scope
or spirit of the invention.

15 Other embodiments of the invention will be apparent to those
skilled in the art from consideration of the specification and
practice of the invention disclosed herein. It is intended that
the specification and examples be considered as exemplary only,
with a true scope and spirit of the invention being indicated by
the following claims.

LAW OFFICES
FINNEGAN, HENDERSON
FARABOW, CARRETT
& DUNNER
1300 I STREET, N.W.
WASHINGTON, DC 20005
1 202 408 4000

WHAT IS CLAIMED IS:

1. A method for information transmission by a plurality of transmitters to provide broad communication capability over a region of space, the information transmission occurring during at least both a first time period and a second time period and the plurality of transmitters being divided into at least a first and second set of transmitters, the method comprising the steps of:
 - (a) generating a system information signal which includes a plurality of blocks of information;
 - (b) transmitting the system information signal to the plurality of transmitters;
 - (c) transmitting by the first and second sets of transmitters a first block of information in simulcast during the first time period;
 - (d) transmitting by the first set of transmitters a second block of information during the second time period; and
 - (e) transmitting by the second set of transmitters a third block of information during the second time period.

LAW OFFICES
FINNEGAN, HENDERSON
FARABOW, GARRETT
& DUNNER
1000 I STREET, N.W.
WASHINGTON, D.C. 20005
1-202-408-4000

(Sub B)

2. A multi-carrier simulcast transmission system for transmitting in a desired frequency band a message contained in an information signal, the system comprising:

first transmitter means for transmitting an information signal by generating a first plurality of carrier signals within the desired frequency band and by modulating the first plurality of carrier signals to convey the information signal; and

second transmitter means, spatially separated from the first transmitter, for transmitting the information signal in simulcast with the first transmitter by generating a second plurality of carrier signals at substantially the same frequencies as the first plurality of carrier signals and by modulating the second plurality of carrier signals to convey the information signal.

LAW OFFICES
FINNEGAN, HENDERSON
FARABOW, GARRETT
& DUNNER
1300 I STREET, N.W.
WASHINGTON, D.C. 20005
1-202-405-4000

3. A communication method implemented in a computer controlled communication network for locating a mobile transceiver within a region of space, the region of space being divided into a plurality of zones with each zone serviced by at least one base transmitter and at least one base receiver, the network storing data corresponding to a zone where the mobile transceiver was last known to be located, the communication method comprising the steps of:

(a) transmitting a message signal by a base transmitter servicing a zone where the mobile transceiver was last known to be located;

(b) transmitting a systemwide probe signal by a plurality of base transmitters servicing a plurality of zones if the mobile transceiver does not indicate receipt of the message signal from the base transmitter;

(c) receiving the regional probe signal by the mobile transceiver;

(d) transmitting an acknowledgment signal by the mobile transceiver in response to the received regional probe signal;

(e) receiving the acknowledgment signal from the mobile transceiver by a base receiver; and

(f) updating the data to reflect the zone of the base receiver that received the acknowledgment signal as the last known location of the mobile transceiver.

4. A method of communicating messages between a plurality of base transmitters and mobile receivers within a region of space divided into a plurality of zones with each zone having at least one base transmitter assigned thereto, the communication method comprising the steps of:

(a) transmitting substantially simultaneously a first information signal and a second information signal to communicate messages to the mobile receivers, the first information signal being transmitted in simulcast by a first set of base transmitters assigned to a first zone, and the second information signal being transmitted in simulcast by a second set of base transmitters assigned to a second zone;

(b) dynamically reassigning one or more of the base transmitters in the first set of base transmitter assigned to the first zone to the second set of base transmitters assigned to the second zone as a function of the messages to be communicated in an area, thereby creating an updated first set of base transmitters and an updated second set of base transmitters; and

(c) transmitting substantially simultaneously a third information signal and a fourth information signal, the third information signal being transmitted in simulcast by the updated first set of base transmitters, and the fourth information signal being transmitted in simulcast by the updated second set of base transmitters to communicate additional messages to said mobile receivers.

LAW OFFICES
FINNEGAN, HENDERSON
FARABOW, GARRETT
& DUNNER
1300 I STREET, N.W.
WASHINGTON, D.C. 20005
1-202-458-4000

5. A mobile transceiver unit for transmitting messages to and receiving messages from a network comprising:

input means for allowing the user to input a user message to the unit;

transmitter means for transmitting a radio frequency signal including the user message from the mobile unit to the network;

receiver means for receiving radio frequency signals having a message from the network;

signal detector means for detecting at least one type of electromagnetic signal generated external to the mobile unit and the network; and

a circuit, connecting the signal detector means to the transmitter means, for disabling the transmitter means upon detection of the electromagnetic signal, thereby preventing unwanted radio frequency transmission.

LAW OFFICES
FINNEGAN, HENDERSON
FARABOW, GARRETT
& DUNNER
1300 I STREET, N.W.
WASHINGTON, D.C. 20005
1-202-408-4000

6. A communication method for controlling a mobile transceiver which may communicate with a communication network controlled by a computer, the network including a plurality of base transmitters for transmitting messages from the network to the mobile transceiver and base receivers for receiving messages from the mobile transceiver, the mobile transceiver being capable of sending a registration signal to be received by a base receiver in the network to identify the mobile transceiver's location and the plurality of base transmitters in the network being capable of sending a probe signal to the mobile transceiver to cause the mobile transceiver to transmit a signal to a base receiver to identify its location, the method comprising the steps of:

(a) sending a message from the network to the mobile transceiver to disable the mobile transceiver's capability to transmit a registration signal;

(b) storing the number of probe signals sent by the network to the mobile transceiver during a first period of time and the number of messages successfully delivered to the mobile transceiver by the network during a second period of time;

(c) processing by the computer the stored number of probe signals and number of messages successfully delivered to evaluate a likelihood that a probe signal will be required to be sent by the network to locate the mobile unit to deliver a message; and

(d) sending a message to the mobile unit to enable the mobile transceiver's capability to transmit a registration signal if the calculated likelihood exceeds a selected value.

LAW OFFICES
FINNEGAN, HENDERSON
FARABOW, GARRETT
& DUNNER
1300 I STREET, N.W.
WASHINGTON, DC 20005
1 202 408-4000

7. A communication method for controlling a mobile transceiver, which may communicate with a communication network controlled by a computer, the network including a plurality of base transmitters for transmitting messages to the mobile transceiver and base receivers for receiving messages from the mobile transceiver, the mobile transceiver being capable of sending a registration signal to be received by a base receiver in the network to identify the mobile transceiver's location, the network using received registration signals to determine a set of base transmitters to be operated to transmit a message to the mobile transceiver, the method comprising the steps of:

(a) sending a message from the network to the mobile transceiver to enable the mobile transceiver's capability to transmit a registration signal;

(b) storing the number of registration signals from the mobile transceiver to the network during a first period of time and the number of messages successfully delivered to the mobile transceiver by the network during a period of time;

(c) processing the stored number of registration signals and number of messages successfully delivered to evaluate a likelihood that a registration signal from said mobile unit will not be used by the network to determine a set of base transmitters; and

(d) sending a message to the mobile unit to disable the mobile transceiver's capability to transmit a registration signal if the likelihood exceeds a selected value.

LAW OFFICES
FINNEGAN, HENDERSON
PARABOW, GARRETT
& DUNNER
1300 I STREET, N.W.
WASHINGTON, DC 20005
1-202-409-4000

Add B3
Add D3

ATTORNEY DOCKET NO: 03680.0083-00000

DECLARATION AND POWER OF ATTORNEY

As a below named inventor, I hereby declare that: my residence, post office address and citizenship are as stated below next to my name; that I believe I am the original, first and sole inventor (if only one name is listed below) or an original, first and joint inventor (if plural names are listed below) of the subject matter which is claimed and for which a patent is sought on the invention entitled:

A NATIONWIDE COMMUNICATION SYSTEM

the specification of which is attached and/or was filed on November 12, 1992..... as Application Serial No. and was amended on (if applicable)

I hereby state that I have reviewed and understand the contents of the above identified specification, including the claims, as amended by any amendment referred to above.

I acknowledge the duty to disclose information which is material to the examination of this application in accordance with Title 37, Code of Federal Regulations, §1.56(a)

I hereby claim foreign priority benefits under Title 35, United States Code, §119 of any foreign application(s) for patent or inventor's certificate listed below and have also identified below any foreign application for patent or inventor's certificate having a filing date before that of the application on which priority is claimed:

Table with 4 columns: COUNTRY, APPLICATION NUMBER, DATE OF FILING, PRIORITY CLAIMED UNDER 35 U.S.C. 119. Includes checkboxes for YES/NO.

I hereby claim the benefit under Title 35, United States Code, §120 of any United States application(s) listed below and, insofar as the subject matter of each of the claims of this application is not disclosed in the prior United States application in the manner provided by the first paragraph of Title 35, United States Code, §112, I acknowledge the duty to disclose material information as defined in Title 37, Code of Federal Regulations, §1.56(a) which occurred between the filing date of the prior application and the national or PCT international filing date of this application:

Table with 3 columns: APPLICATION NUMBER, DATE OF FILING, STATUS (Patented, Pending, Abandoned)

I hereby appoint the following attorneys to prosecute this application and transact all business in the Patent and Trademark Office connected therewith: Finnegan, Henderson, Farabow, Garrett and Dunner, Reg. No. 22,540; Douglas B. Henderson, Reg. No. 20,291; Ford F. Farabow, Jr., Reg. No. 20,630; Arthur S. Garrett, Reg. No. 20,338; Donald R. Dunner, Reg. No. 19,073; Brian G. Brunsvold, Reg. No. 22,593; Tipton D. Jennings, IV, Reg. No. 20,645; Jerry D. Voight, Reg. No. 23,020; Laurence R. Hefter, Reg. No. 20,827; Kenneth E. Payne, Reg. No. 23,098; Herbert H. Mintz, Reg. No. 26,691; C. Larry O'Rourke, Reg. No. 26,014; Albert J. Santorelli, Reg. No. 22,610; Michael C. Elmer, Reg. No. 25,857; Richard H. Smith, Reg. No. 20,609; Stephen L. Peterson, Reg. No. 26,325; John M. Romary, Reg. No. 26,331; Bruce C. Zotter, Reg. No. 27,680; Dennis P. O'Reilly, Reg. No. 27,932; Allen M. Sokal, Reg. No. 26,695; Robert D. Bajefsky, Reg. No. 25,387; Richard L. Stroup, Reg. No. 28,478; David W. Hill, Reg. No. 28,220; Thomas L. Irving, Reg. No. 28,619; Charles E. Lipsey, Reg. No. 28,165; Thomas W. Winland, Reg. No. 27,605; Basil J. Lewis, Reg. No. 28,818; Robert J. Gaybrick, Reg. No. 27,890; Martin I. Fuchs, Reg. No. 28,508; E. Robert Yoches, Reg. No. 30,120; Stephen J. Rosenman, Reg. No. 29,209; Barry W. Graham, Reg. No. 29,924; Thomas H. Jenkins, Reg. No. 30,857; and MATTHEW T. BAILEY, Reg. No. 33,829.

See paper #108

Please address all correspondence to FINNEGAN, HENDERSON, FARABOW, GARRETT AND DUNNER, 1300 I Street, N.W., Washington, D.C. 20005, Telephone No. (202) 408-4000.

I hereby declare that all statements made herein of my own knowledge are true and that all statements made on information and belief are believed to be true; and further that these statements were made with the knowledge that willful false statements and the like so made are punishable by fine or imprisonment, or both, under Section 1001 of Title 18 of the United States Code and that such willful false statements may jeopardize the validity of the application or any patent issued thereon.

100

Form for DENNIS WAYNE CAMERON, Inventor. Includes fields for signature, date (1/11/92), residence (29 POLO DRIVE, JACKSON, MS 39211), and citizenship (U.S.A.).

200

Form for WALTER CHARLES ROEHR, Second Joint Inventor. Includes fields for signature, date (8 JAN '93), residence (11317 SOUTH SHORE ROAD, RESTON, VA 22090), and citizenship (U.S.A.).

Listing of Inventors Continued on Page 2 hereof. Yes No

FINNEGAN, HENDERSON, FARABOW, GARRETT & DUNNER • WASHINGTON, D.C.

FHFGD Form

Listing of Inventors Continued from Page 1 of Declaration and Power of Attorney for invention entitled:

A NATIONWIDE COMMUNICATION SYSTEM

300	FULL NAME OF THIRD JOINT INVENTOR, IF ANY <u>RADE PETROVIC</u>	INVENTOR'S SIGNATURE <i>Rade Petrovic</i>	DATE <u>1-11-93</u>
	RESIDENCE <u>406 REDBUD LANE, OXFORD, MS 38655 MS</u>	CITIZENSHIP <u>YUGOSLAVIA</u>	
	POST OFFICE ADDRESS <u>P.O. BOX 9031, UNIVERSITY, MS 38677</u>		
400	FULL NAME OF FOURTH JOINT INVENTOR, IF ANY <u>JAI P. BHAGAT</u>	INVENTOR'S SIGNATURE <i>Jai P. Bhagat</i>	DATE <u>1-6-93</u>
	RESIDENCE <u>155 ROLLING MEADOWS DRIVE, JACKSON, MS 39211 MS</u>	CITIZENSHIP <u>U.S.A.</u>	
	POST OFFICE ADDRESS <u>155 ROLLING MEADOWS DRIVE, JACKSON, MS 39211</u>		
500	FULL NAME OF FIFTH JOINT INVENTOR, IF ANY <u>MASOOD GARAH</u>	INVENTOR'S SIGNATURE <i>Masood Garah</i>	DATE <u>1/7/93</u>
	RESIDENCE <u>454 MORNING FOREST LANE, MADISON, MS 39110 MS</u>	CITIZENSHIP <u>U.S.A.</u>	
	POST OFFICE ADDRESS <u>454 MORNING FOREST LANE, MADISON, MS 39110</u>		
600	FULL NAME OF SIXTH JOINT INVENTOR, IF ANY <u>WILLIAM D. HAYS</u>	INVENTOR'S SIGNATURE <i>William D. Hays</i>	DATE <u>1-6-93</u>
	RESIDENCE <u>2345 TWIN LAKE CIRCLE, JACKSON, MS 39211 MS</u>	CITIZENSHIP <u>U.S.A.</u>	
	POST OFFICE ADDRESS <u>2345 TWIN LAKE CIRCLE, JACKSON, MS 39211</u>		
700	FULL NAME OF SEVENTH JOINT INVENTOR, IF ANY <u>DAVID W. ACKERMAN</u>	INVENTOR'S SIGNATURE <i>David W. Ackerman</i>	DATE <u>1-8-93</u>
	RESIDENCE <u>3730 W STREET, N.W., WASHINGTON, DC 20007 DC</u>	CITIZENSHIP <u>U.S.A.</u>	
	POST OFFICE ADDRESS <u>3730 W STREET, N.W., WASHINGTON, DC 20007</u>		
	FULL NAME OF EIGHTH JOINT INVENTOR, IF ANY	INVENTOR'S SIGNATURE	DATE
	RESIDENCE	CITIZENSHIP	
	POST OFFICE ADDRESS		
	FULL NAME OF NINTH JOINT INVENTOR, IF ANY	INVENTOR'S SIGNATURE	DATE
	RESIDENCE	CITIZENSHIP	
	POST OFFICE ADDRESS		

08/760457
899,476

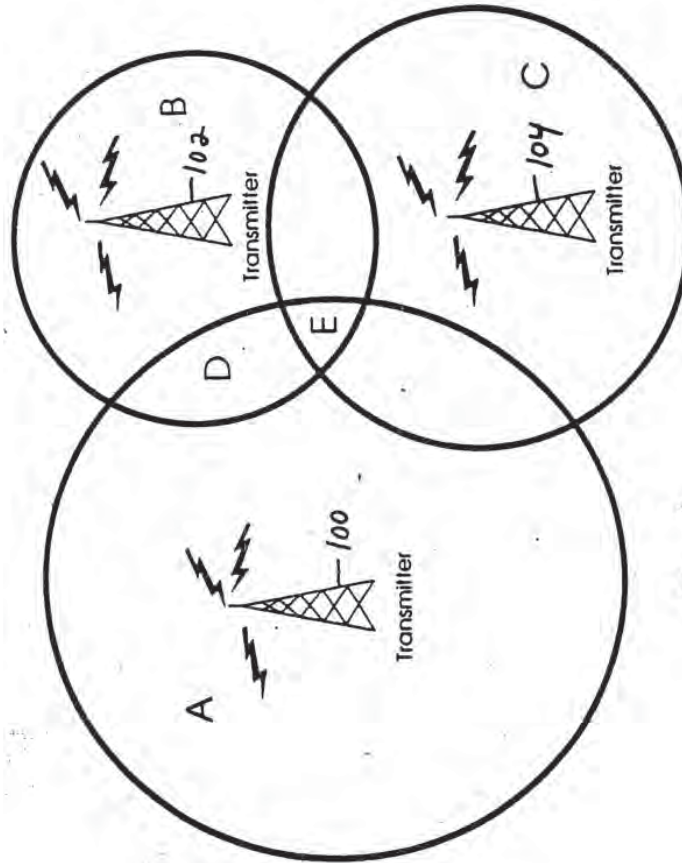

Fig. 1

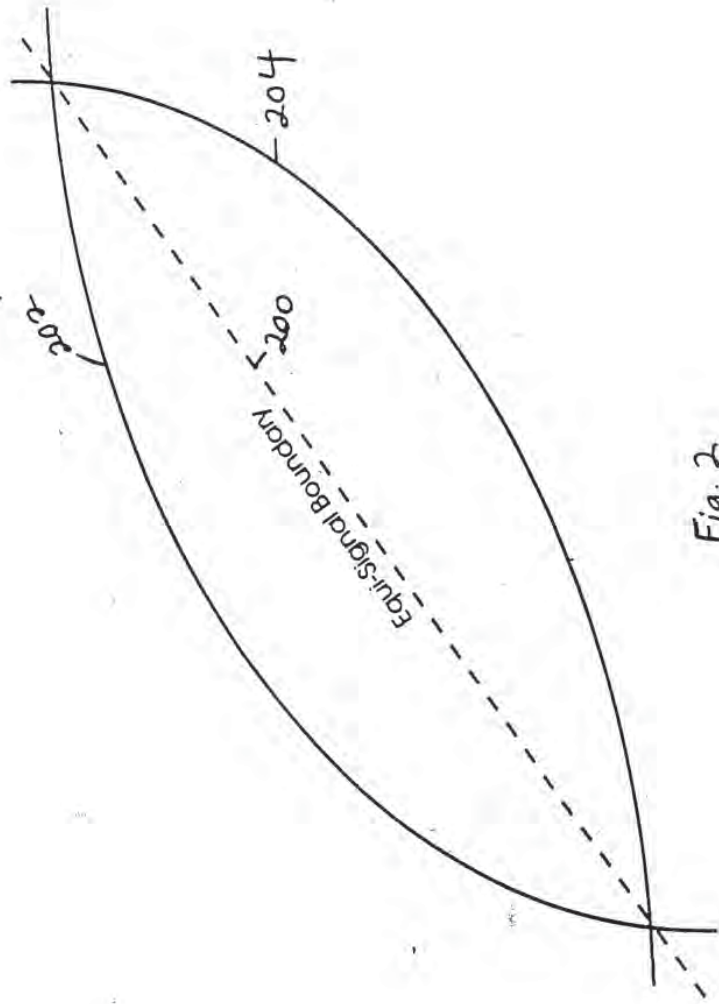

Fig. 2

899,476
~~760457~~

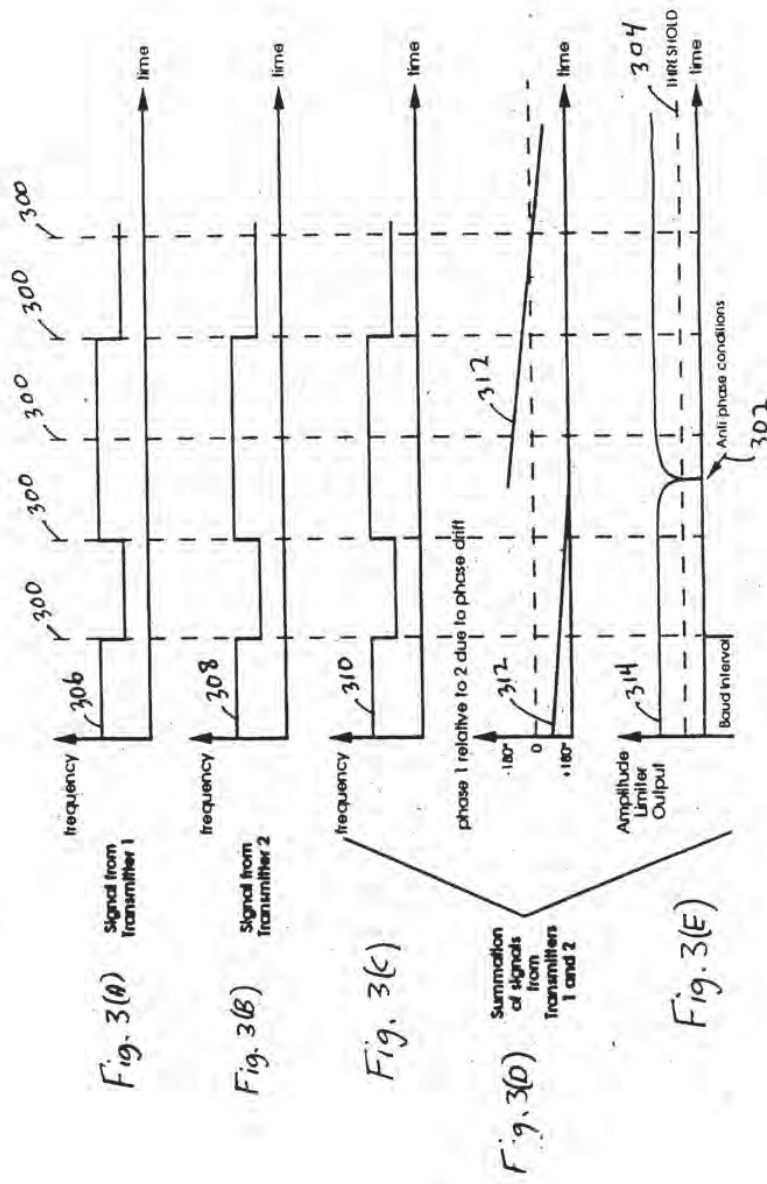

Fig. 3

899,476
08/760457

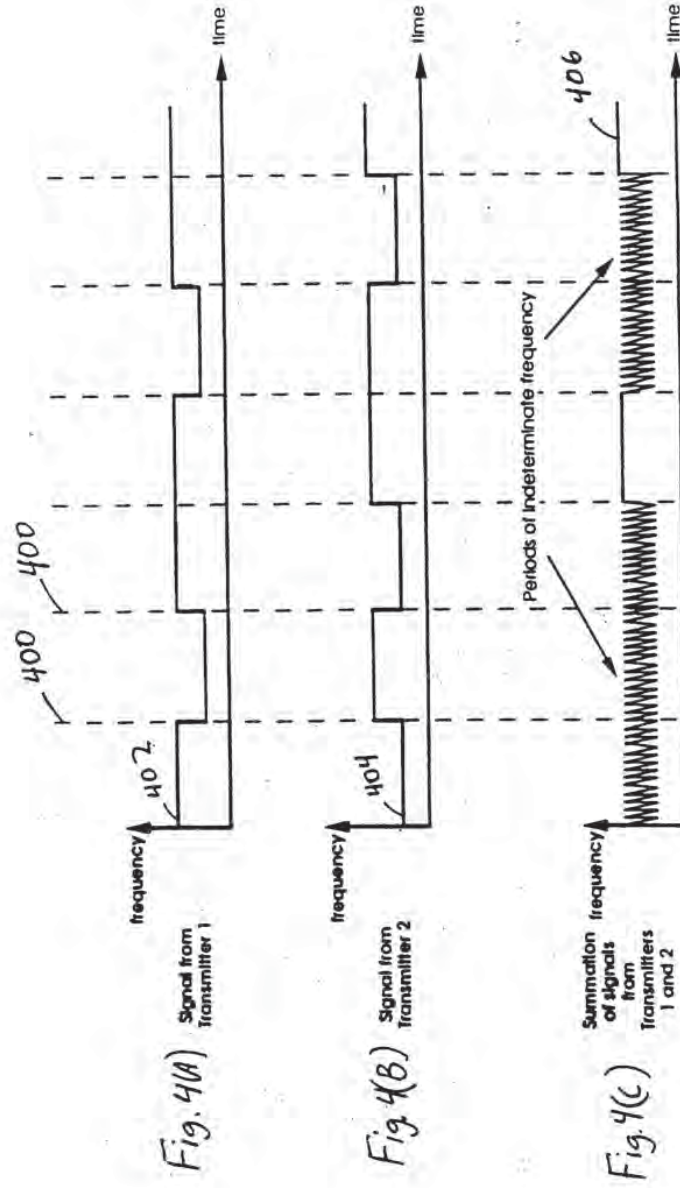

Fig. 4

89,476
~~08/760457~~

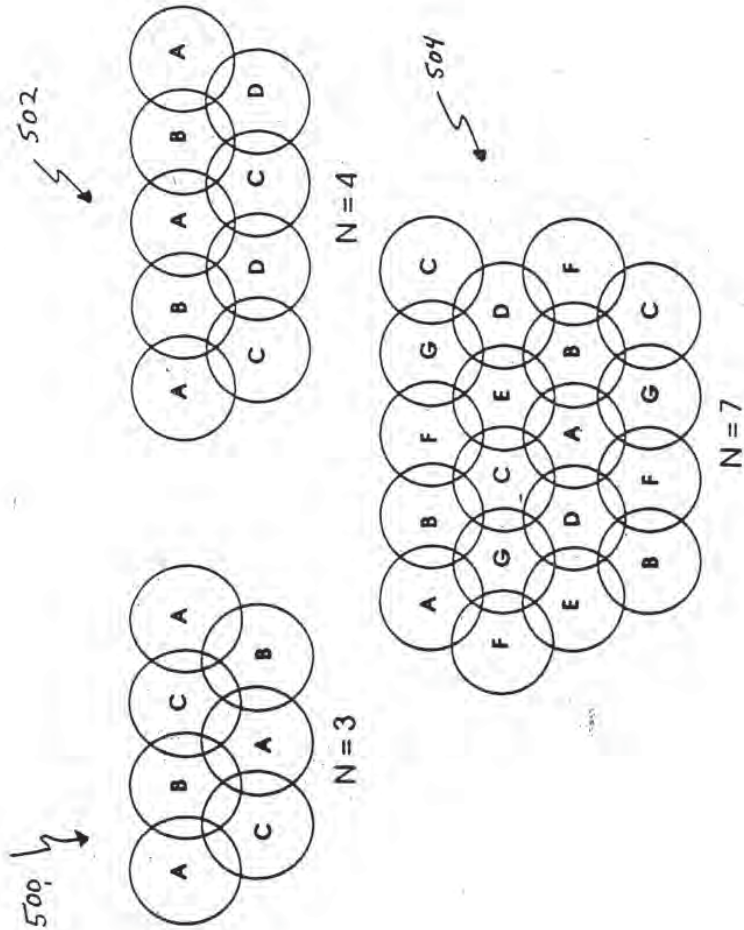

Fig. 5

899,476
08/760457

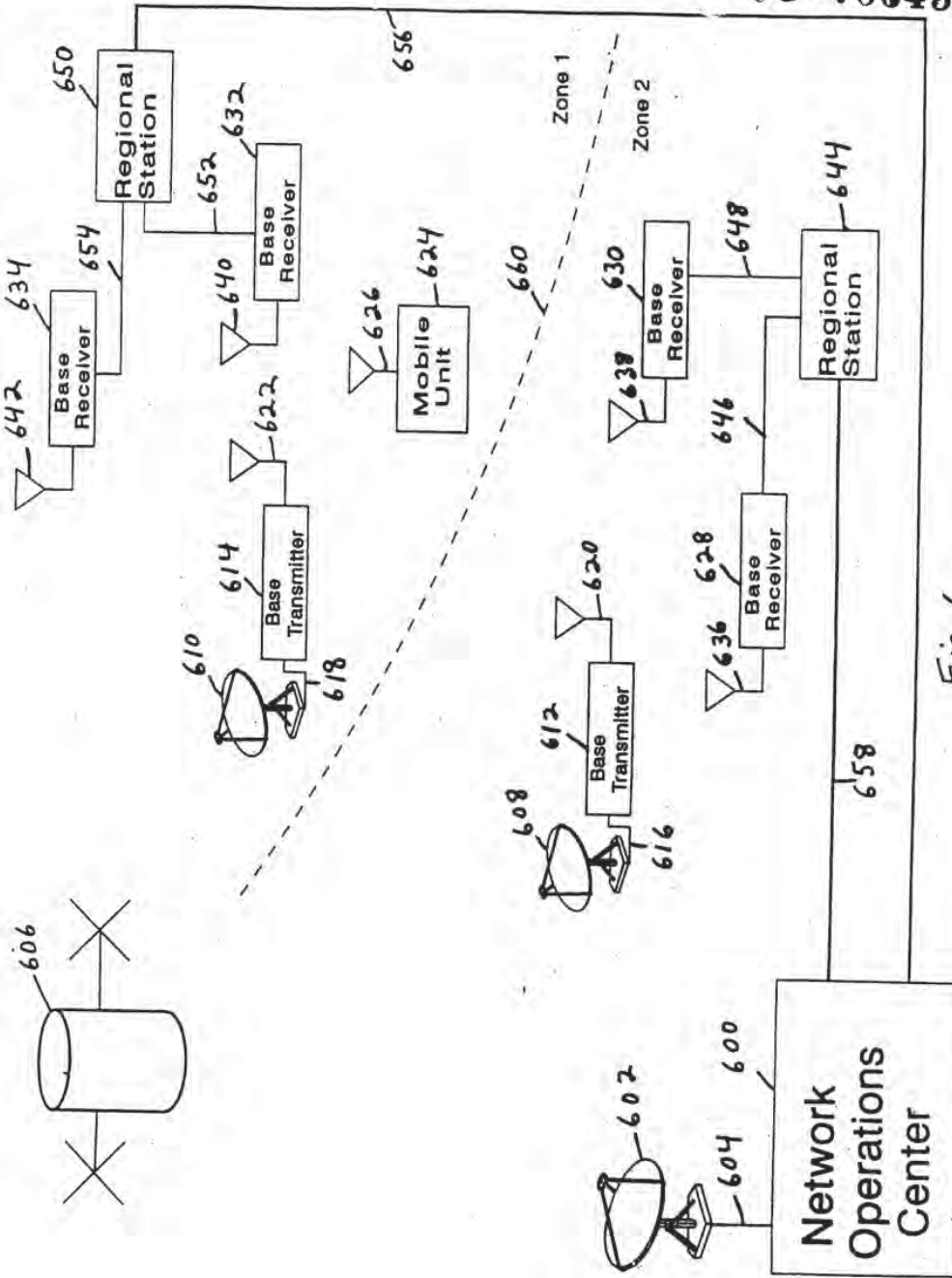

Fig. 6

08 / ~~700457~~
899,476

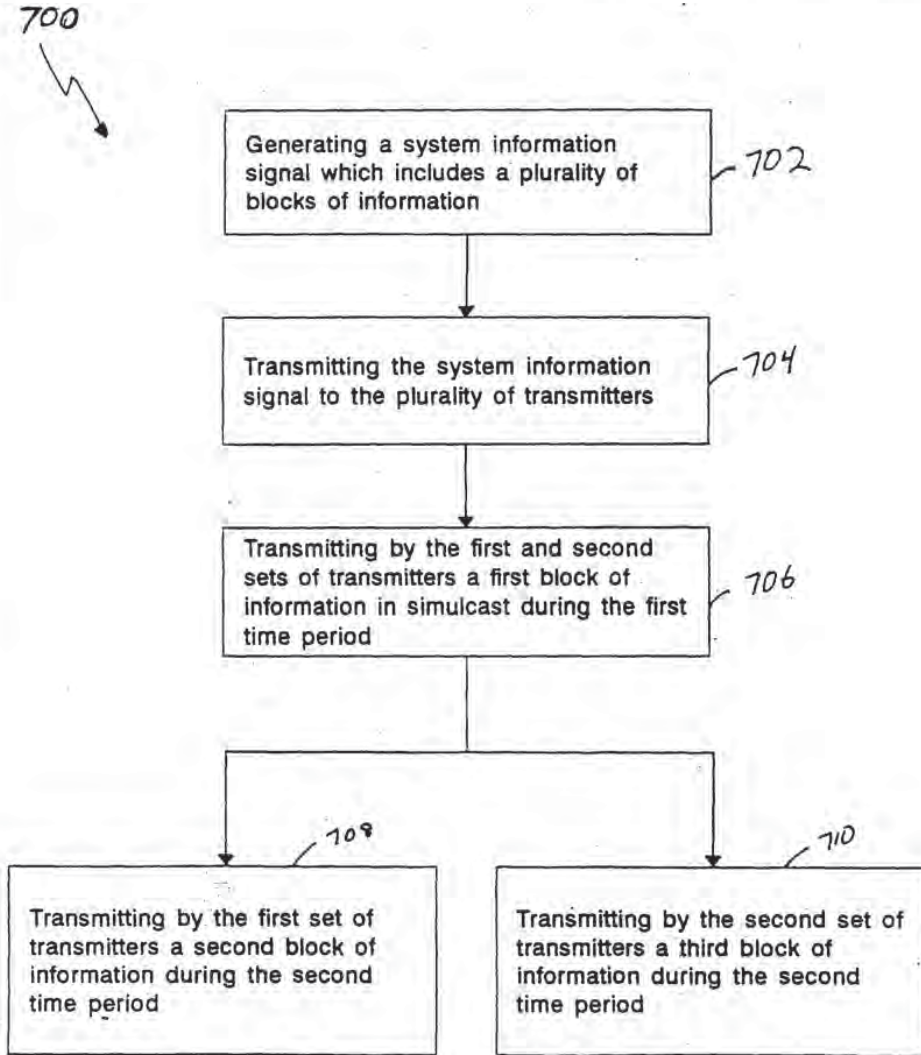

Fig. 7

08/760457
899,476

800

Transmitting a message signal by a base transmitter servicing a zone where the mobile transceiver was last known to be located

802

Transmitting a regional probe signal by a plurality of base transmitters servicing a plurality of zones if the mobile transceiver does not indicate receipt of the message signal from the base transmitter

804

Receiving the regional probe signal by the mobile transceiver

806

Transmitting an acknowledgment signal by the mobile transceiver in response to the received regional probe signal

808

Receiving the acknowledgment signal from the mobile transceiver by a base receiver

810

Updating the data to reflect the zone of the base receiver that received the acknowledgment signal as the last known location of the mobile transceiver

812

Fig. 8

PRINT OF DRAWINGS
AS ORIGINALLY FILED

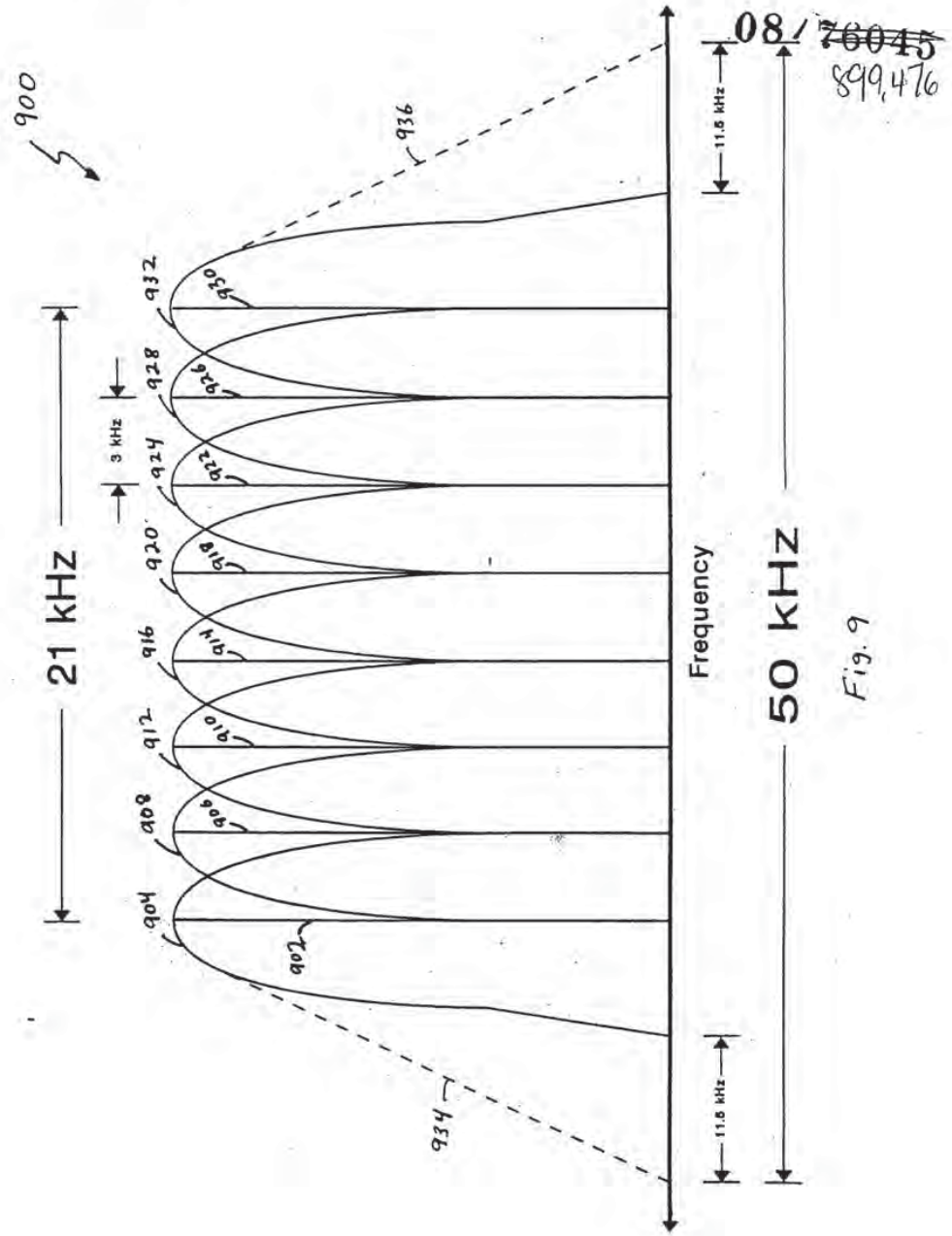

Fig. 9

~~08/760457~~
899,476

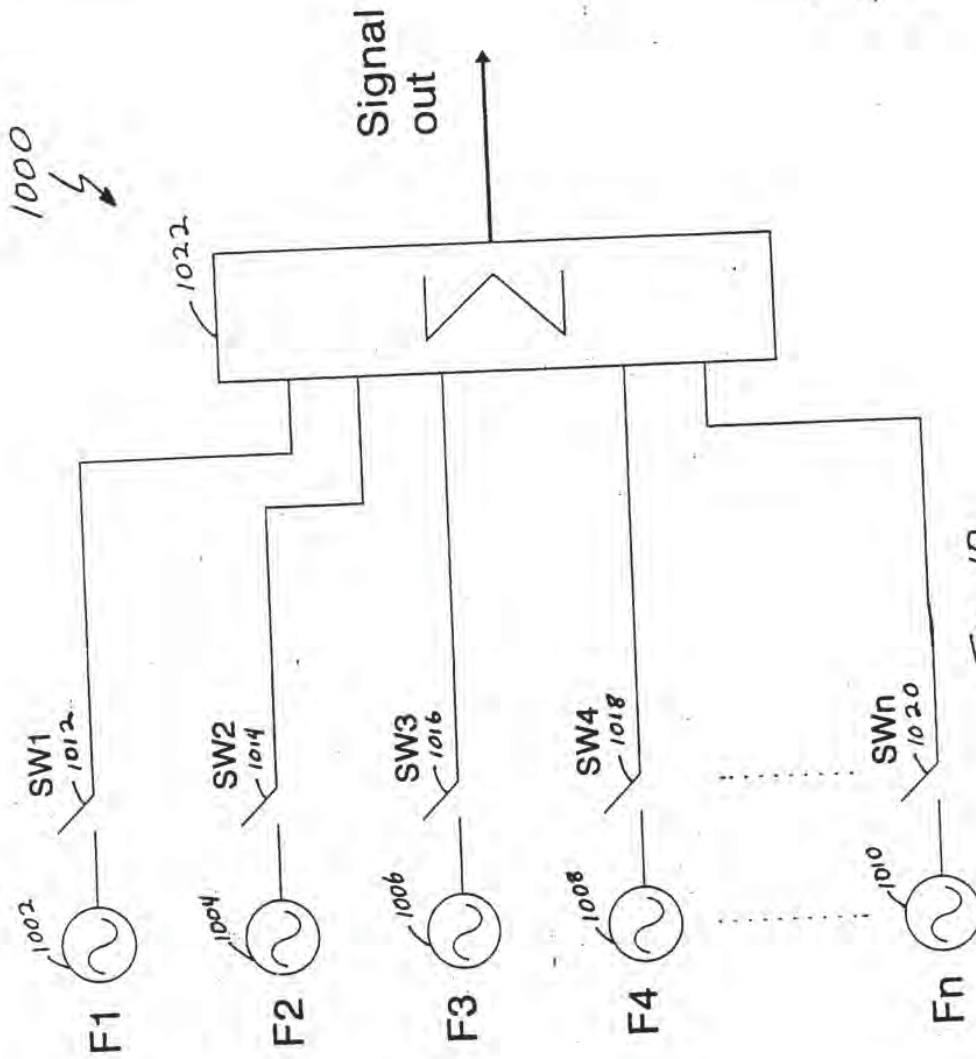

Fig. 10

08/260457
899,476

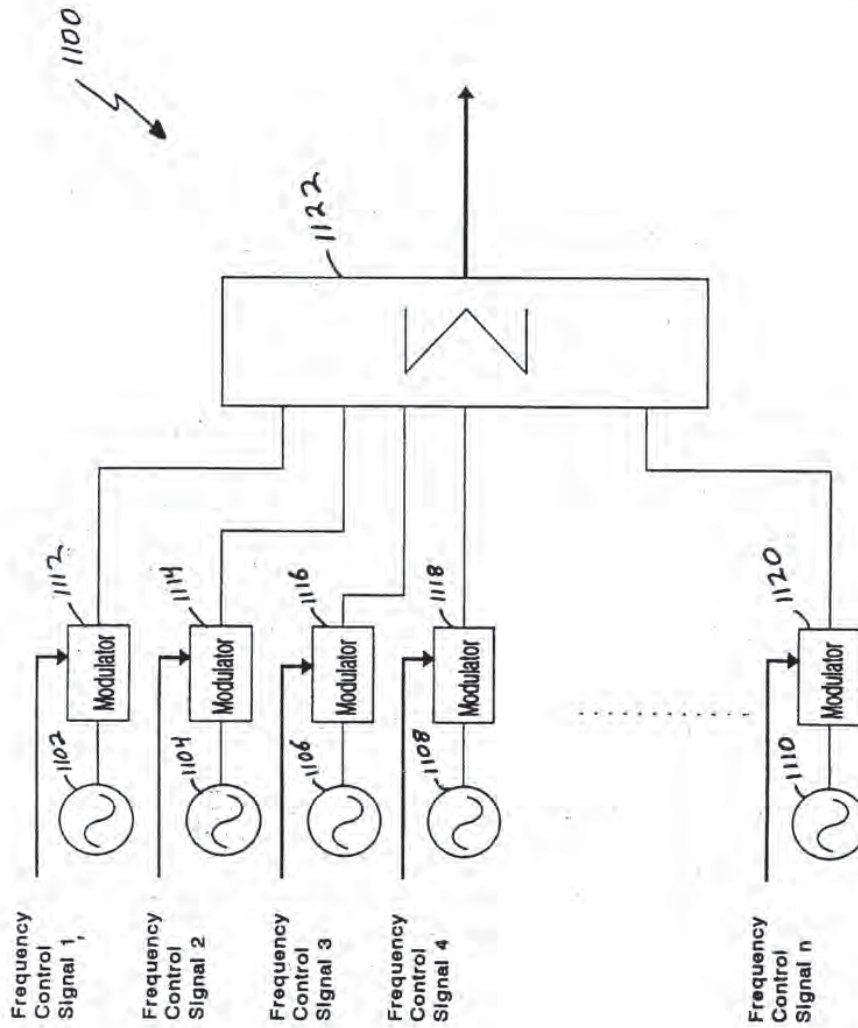
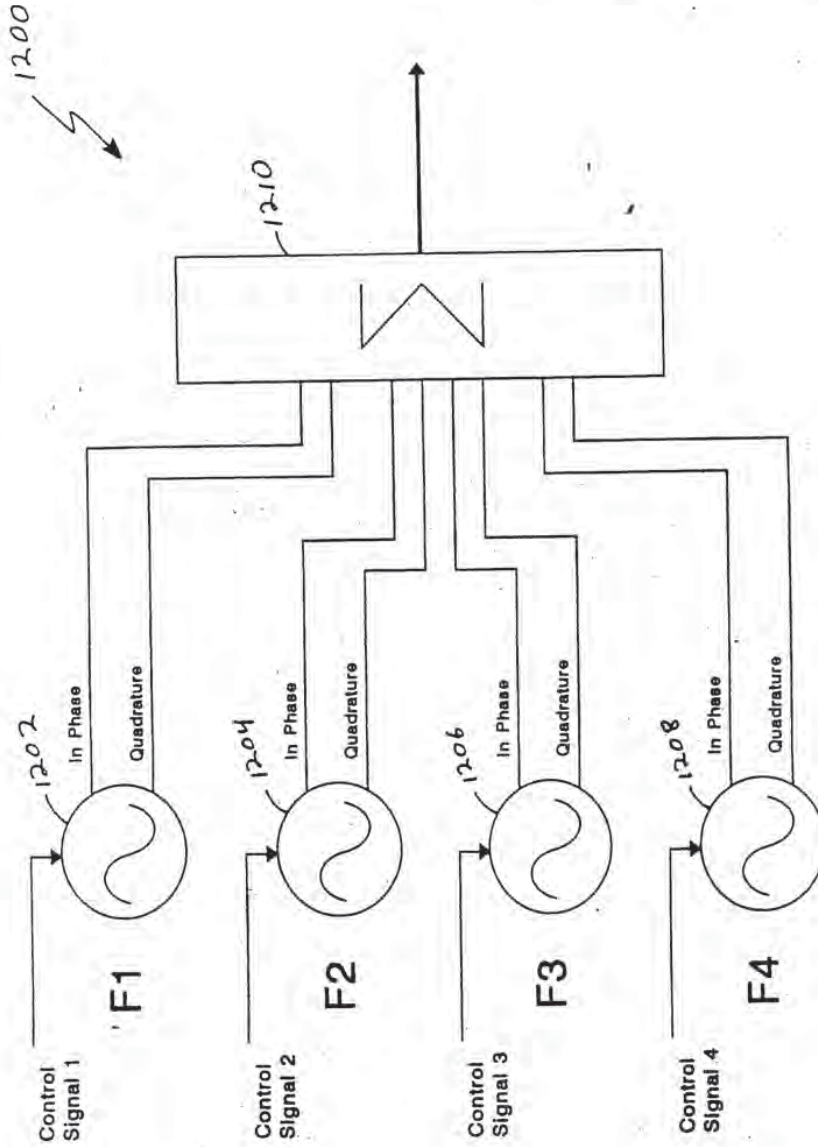

Fig. 11

08/760457
899,476



Four Carrier Quadrature Modulator

Fig. 12

PRINT OF DRAWINGS
AS ORIGINALLY FILED

08/760457
899,476

Base Transmitter

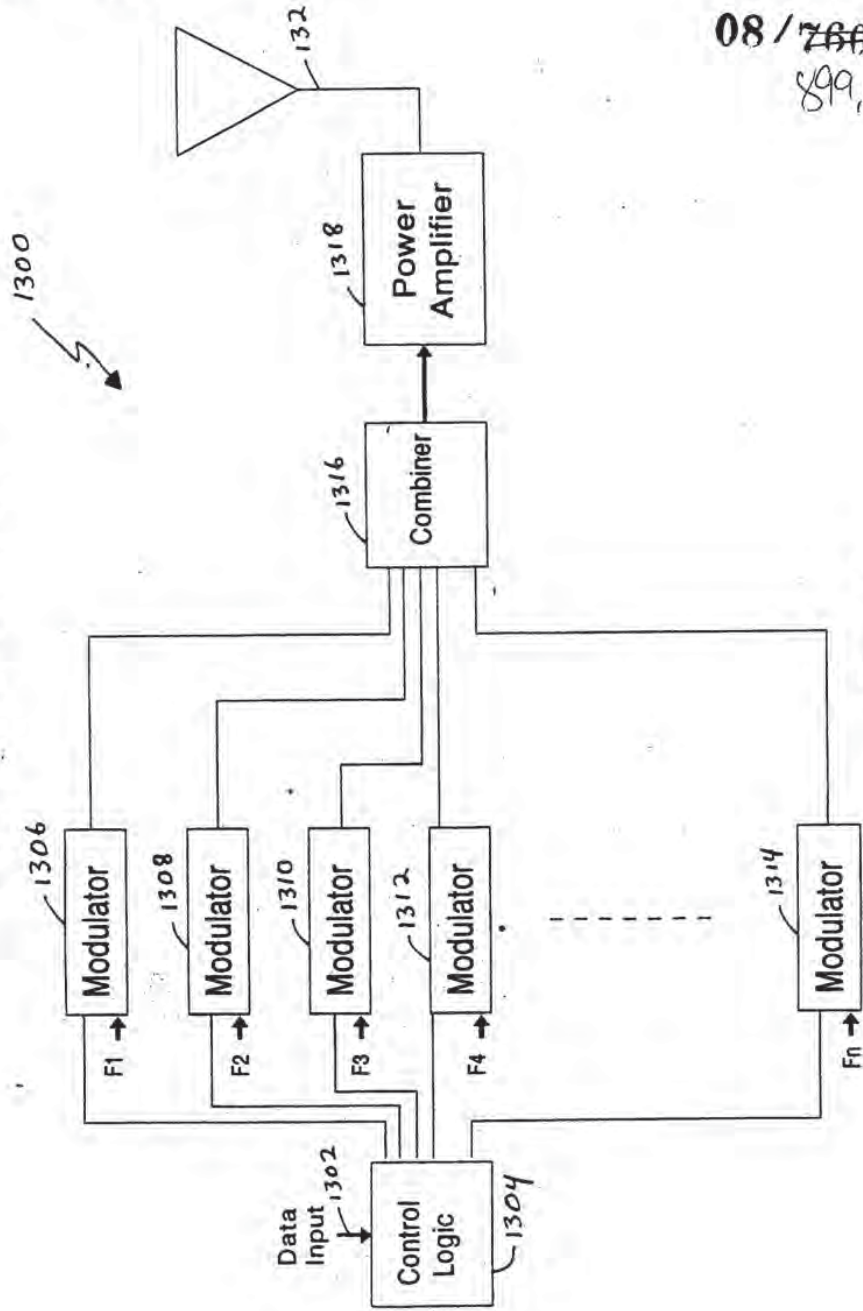

Fig. 13

08/760457
899,476

1400

Base Transmitter

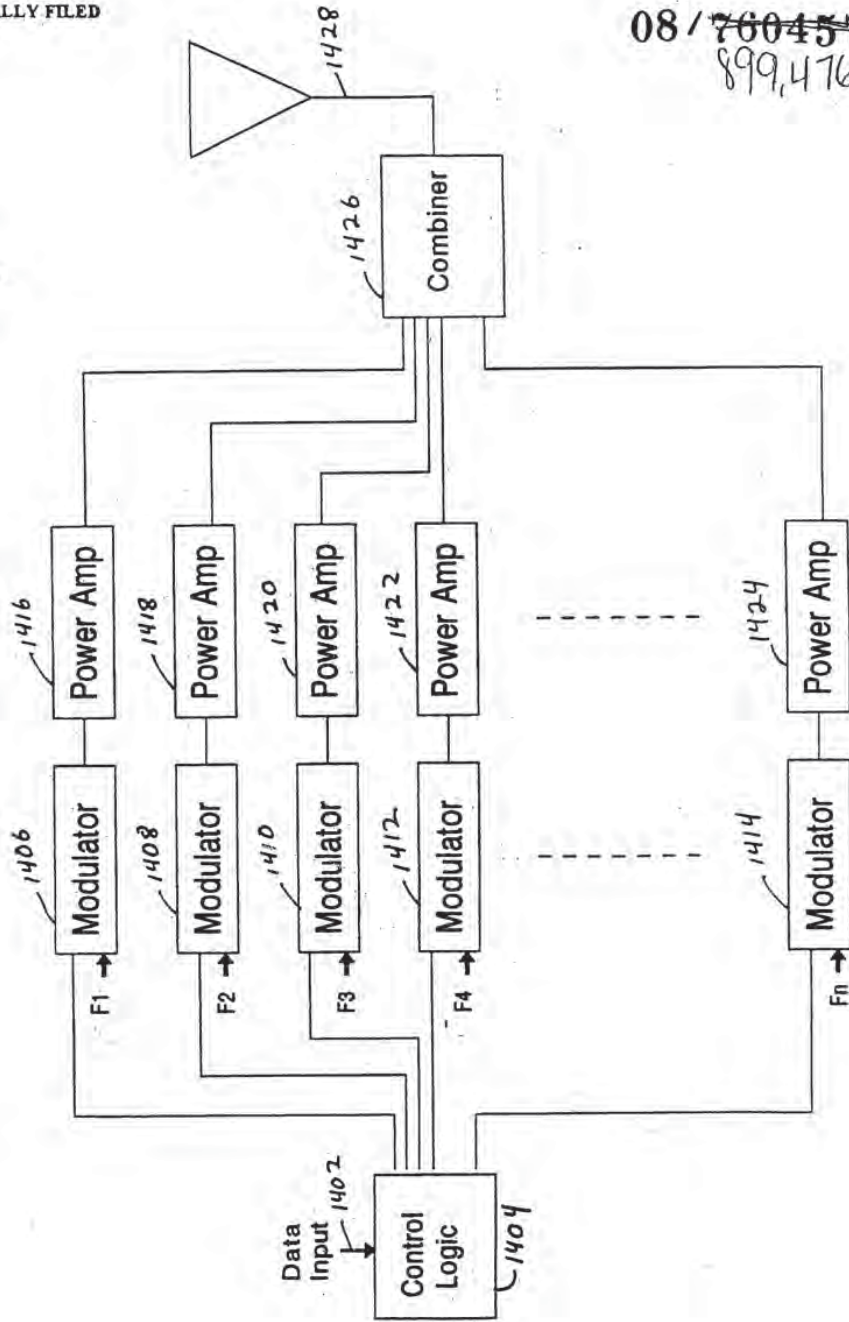

Fig. 14

08/77045
899,476

Mobile Transceiver

1500

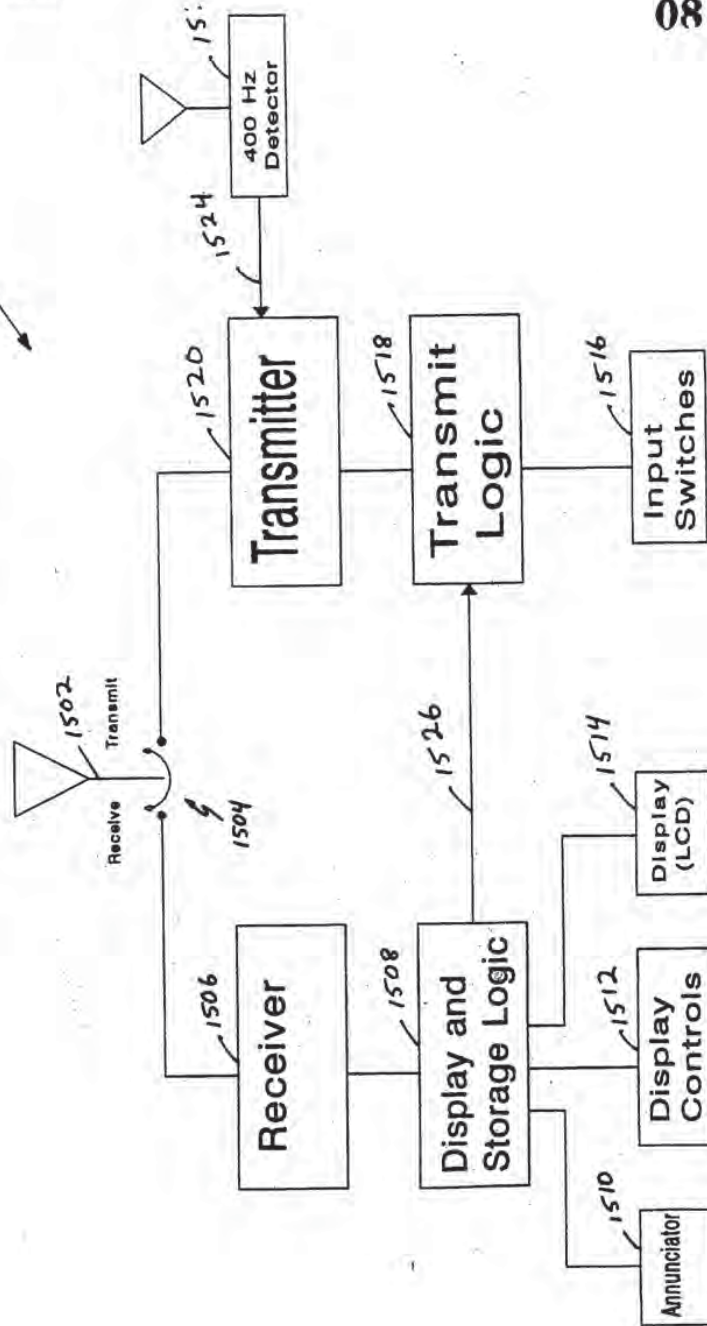

Fig. 15

08/260457
899,476

1600



1602

1604

1606

1620

Will You Be Home For Dinner?

Yes	No	?	Unused	Unused	Unused
1608	1610	1612	1614	1616	1618

Mobile Transceiver

Fig. 16

08 / ~~760457~~
899,476

Mobile Receiver

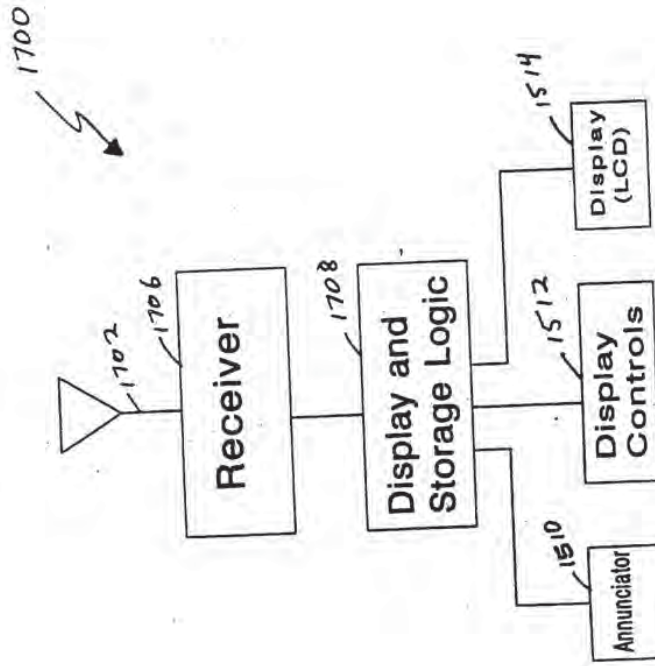

Fig. 17

08/760457
899,476

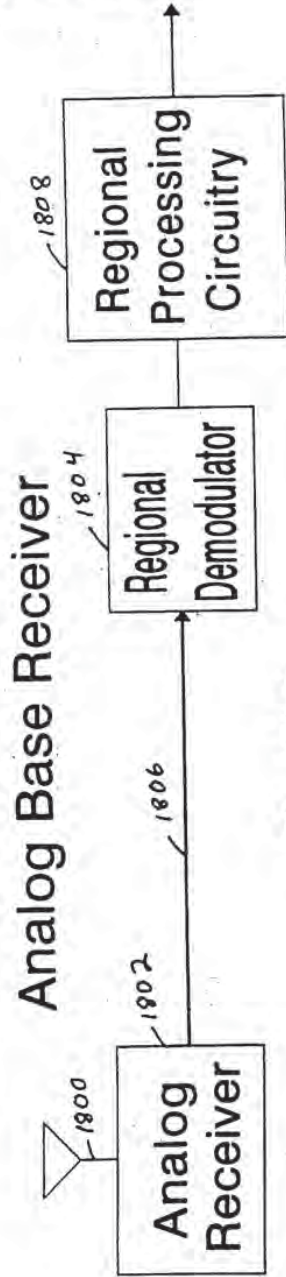

Fig. 18(A)

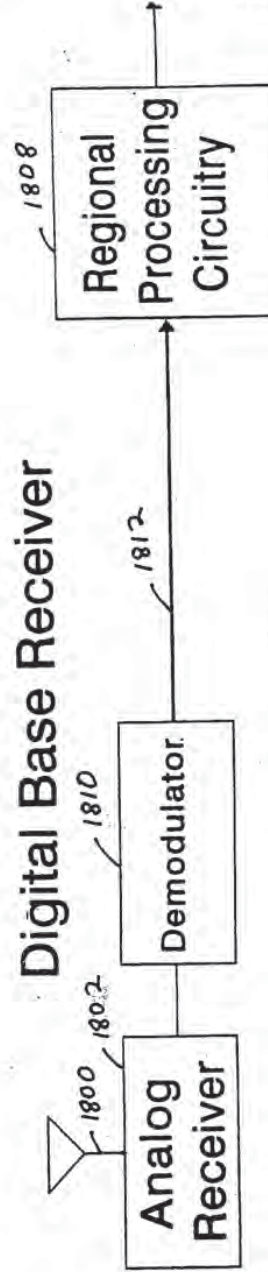

Fig. 18(B)

08/260457
899,476

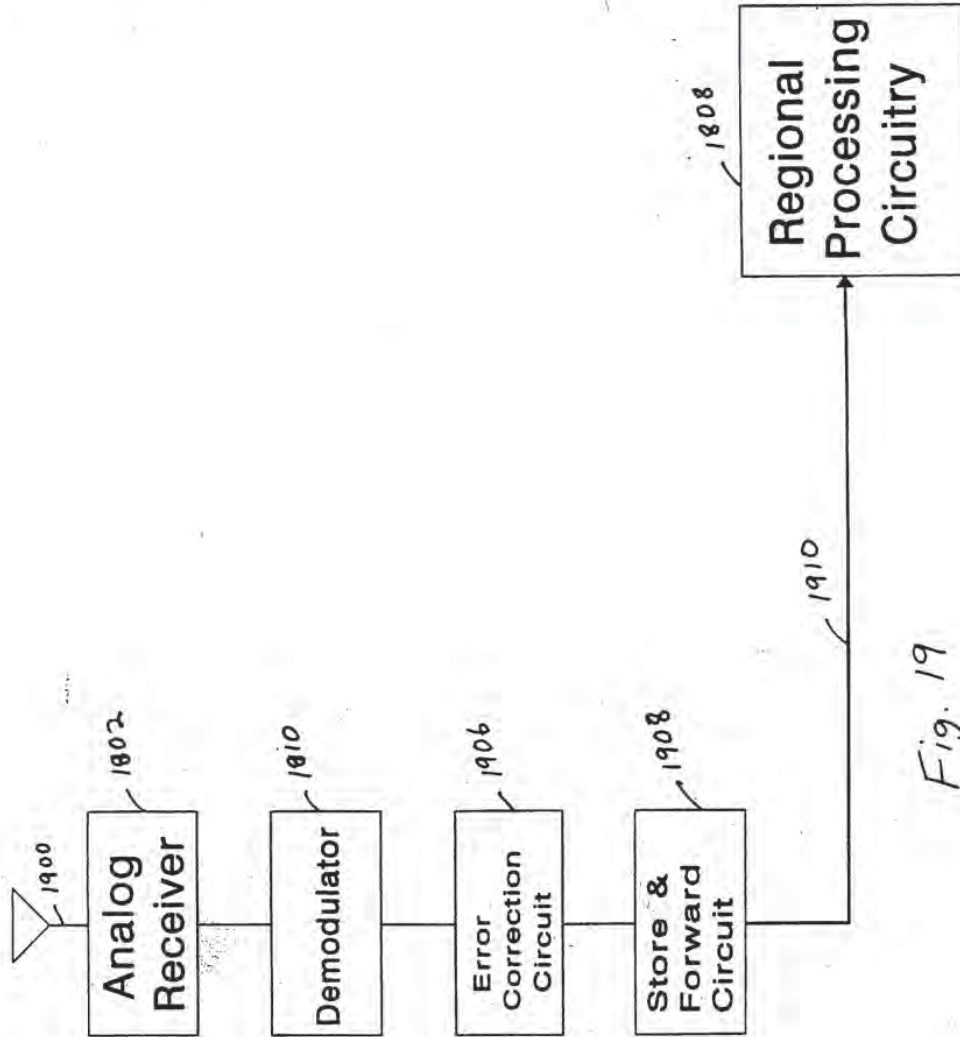

Fig. 19

08/760457
899.476

Network Operations Center

600

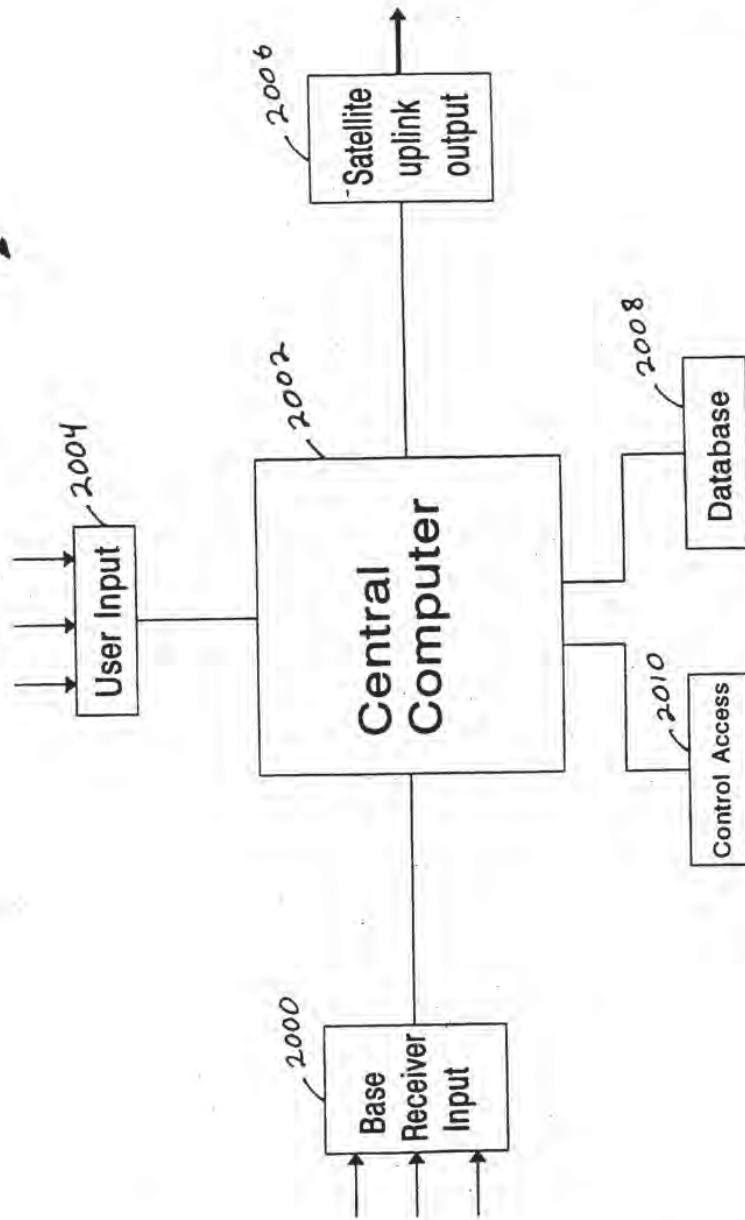

Fig. 20

08/760457

899,476

2100

2102		2104		2106	
User 1	ID#	Last Location	Transmit Capability?		
Service Area		Message	Rec'd		
Button Format					

User 2	ID#	Last Location	Transmit Capability?		
Service Area		Message	Rec'd		
Button Format					

2108

2110

2112

User Database

Fig. 21

08 / ~~950055~~
899,476

2200 ↙

2202 ↙	2204 ↙	2206 ↙	2208 ↙	2210 ↙
User 1	No. of Probe Signals Sent	No. of Registration Signals Received	No. of Messages Successfully Delivered	Other Traffic Data
User 2	No. of Probe Signals Sent	No. of Registration Signals Received	No. of Messages Successfully Delivered	Other Traffic Data
User 3	No. of Probe Signals Sent	No. of Registration Signals Received	No. of Messages Successfully Delivered	Other Traffic Data
User 4	No. of Probe Signals Sent	No. of Registration Signals Received	No. of Messages Successfully Delivered	Other Traffic Data
■ ■ ■ ■				

Traffic Database
Fig. 22

Service Queue

2300 ↘

Current Messages	
ID#	Data Location
2302	2308
2304	2310
2306	2312
⋮	⋮
Probe List	
ID#	Data Location
2314	2320
2316	2322
2318	2324
⋮	⋮

Fig. 23

08/760457
899,476

2408

2406

2404

2402

Base Transmitter 1	Zonal Assignment	Base Receivers in Coverage Area	Other Data
Base Transmitter 2	Zonal Assignment	Base Receivers in Coverage Area	Other Data
Base Transmitter 3	Zonal Assignment	Base Receivers in Coverage Area	Other Data
Base Transmitter 4	Zonal Assignment	Base Receivers in Coverage Area	Other Data

■ ■ ■

Base Transmitter Database

Fig. 24

08/260457
899,476

Zone Dithering

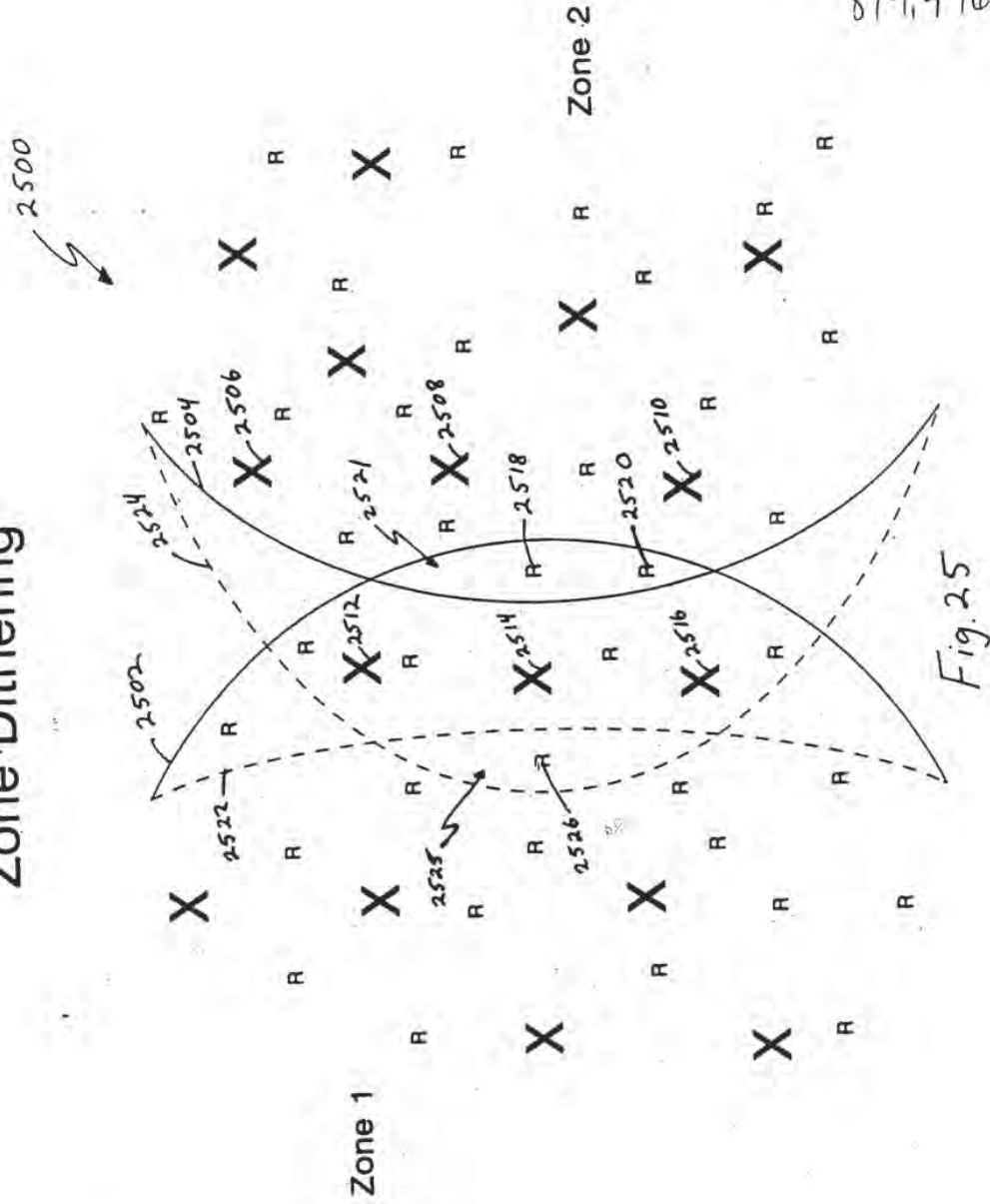

08/26/05
899.476
2600!

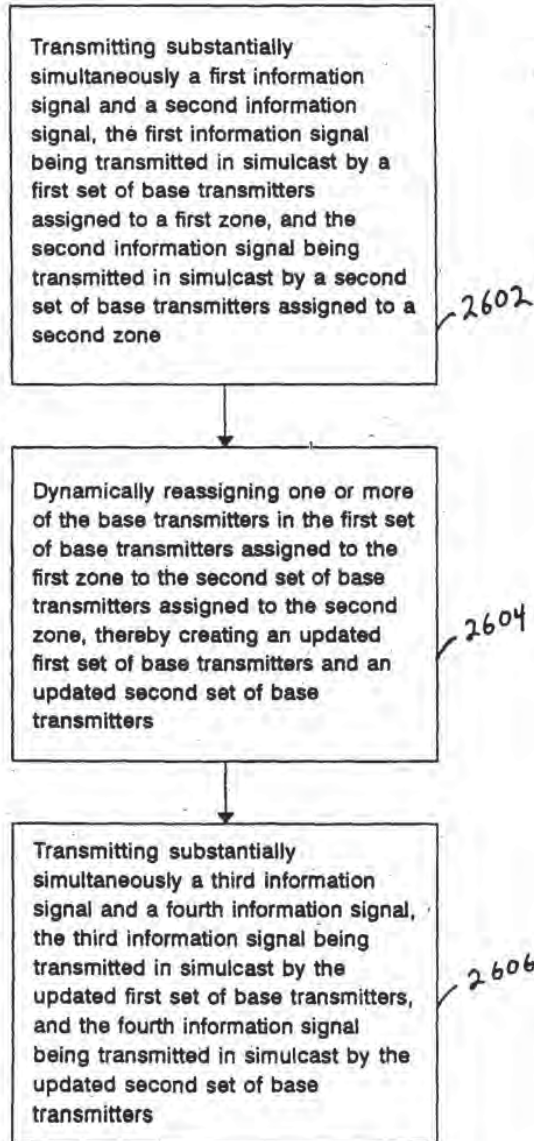

Fig. 26



Fig. 27(A)

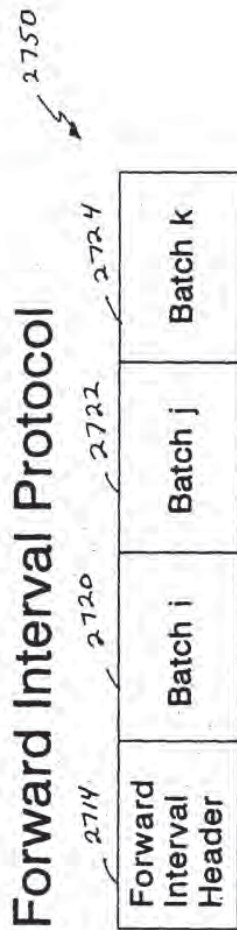

Fig. 27(B)



Fig. 27(C)

08/760457
 899,476

PRINT OF DRAWINGS
AS ORIGINALLY FILED

08/73045
899,476

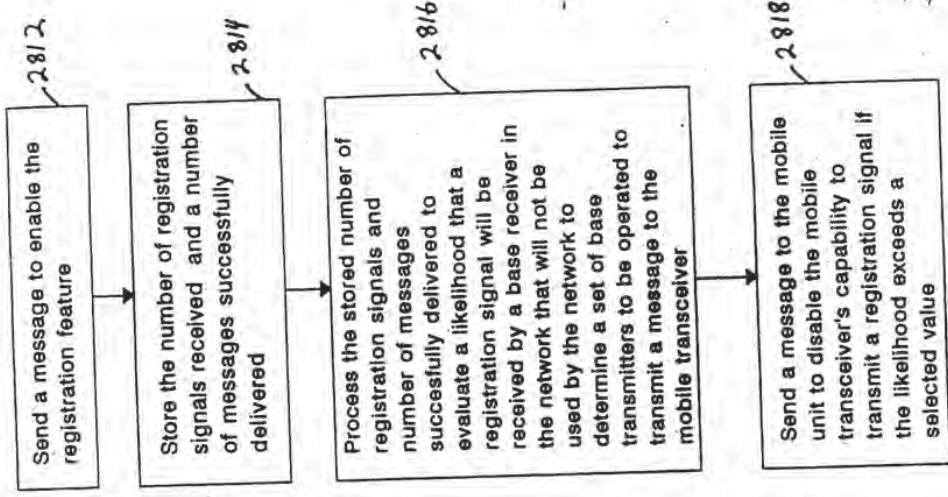

Fig. 28(B)

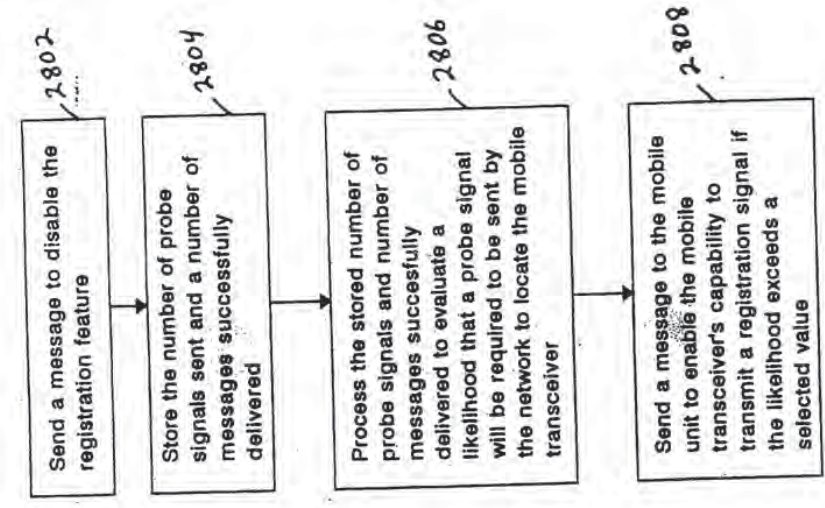

Fig. 28(A)

2800 ↗

08/760457
899,476

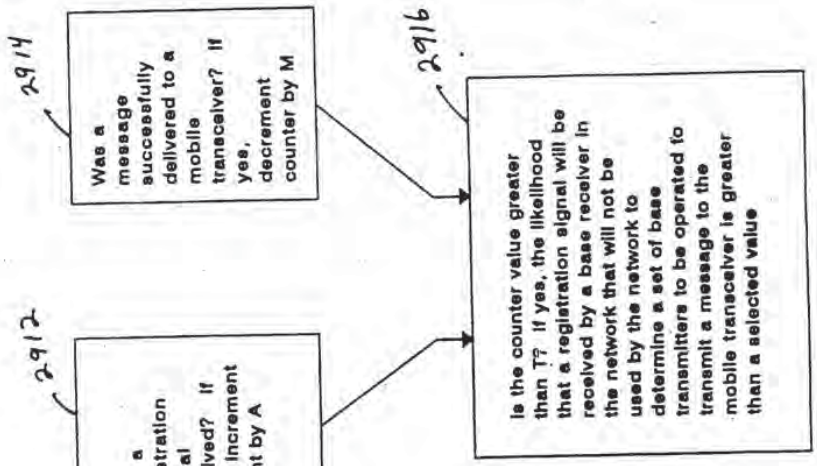

Fig. 29(B)

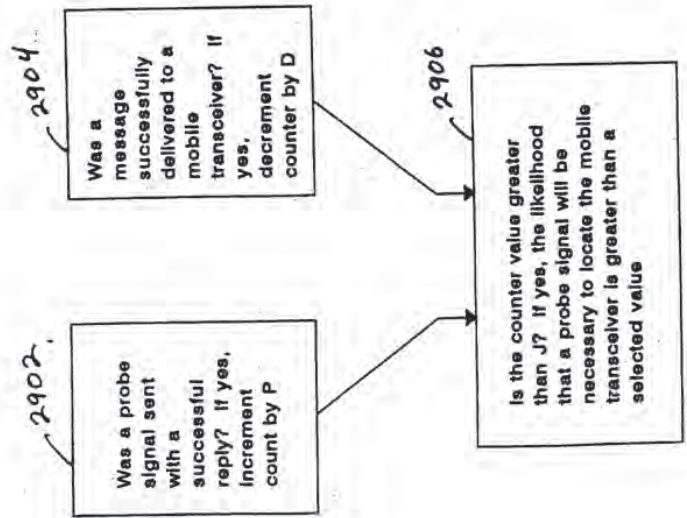

Fig. 29(A)

08/260457
899,476

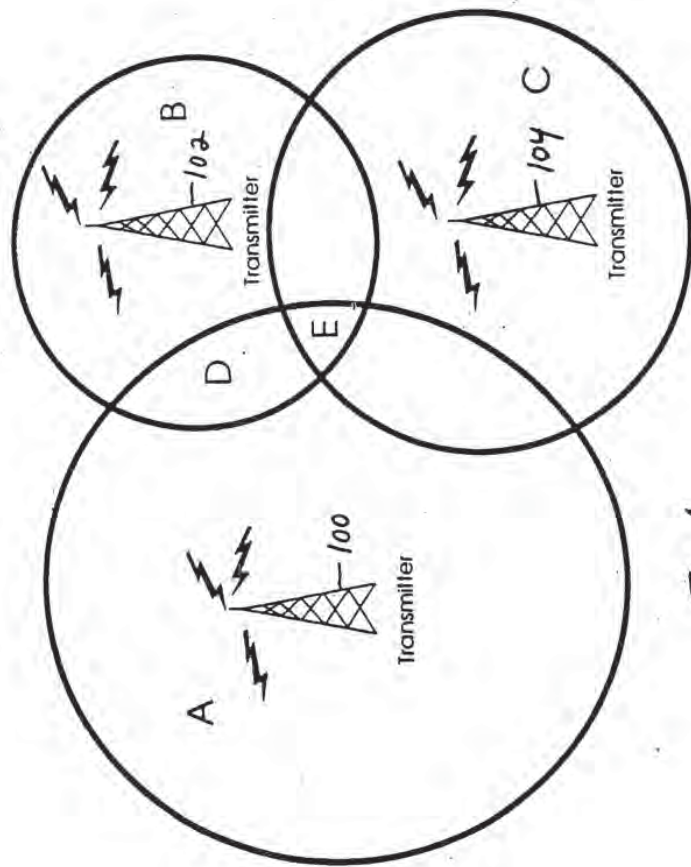

Fig. 1

40

08/2899476
~~760457~~

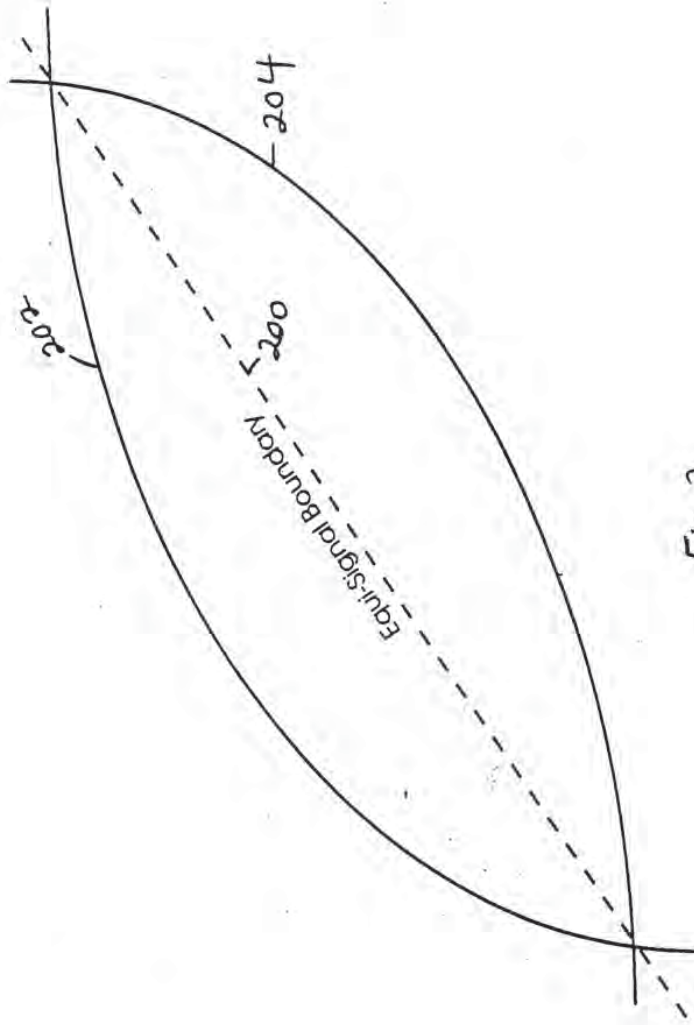

Fig. 2

899,476
NR 1760457

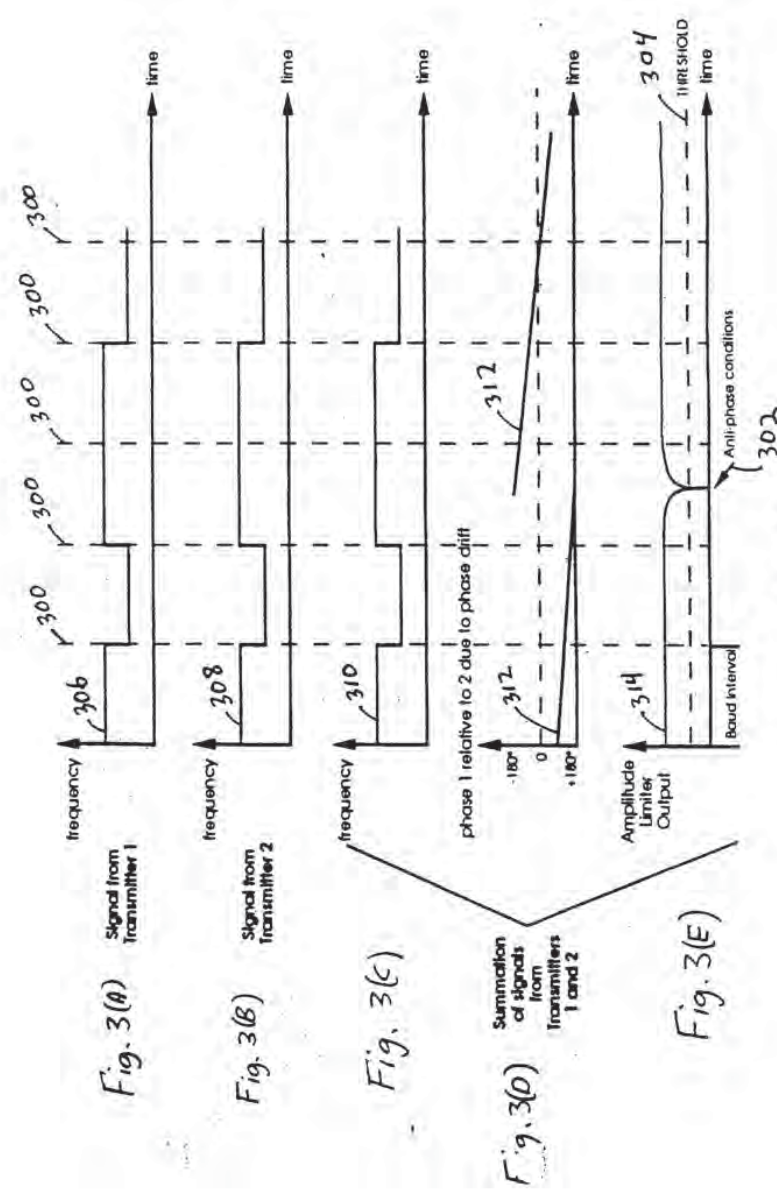

Fig. 3

899,476
08/760457

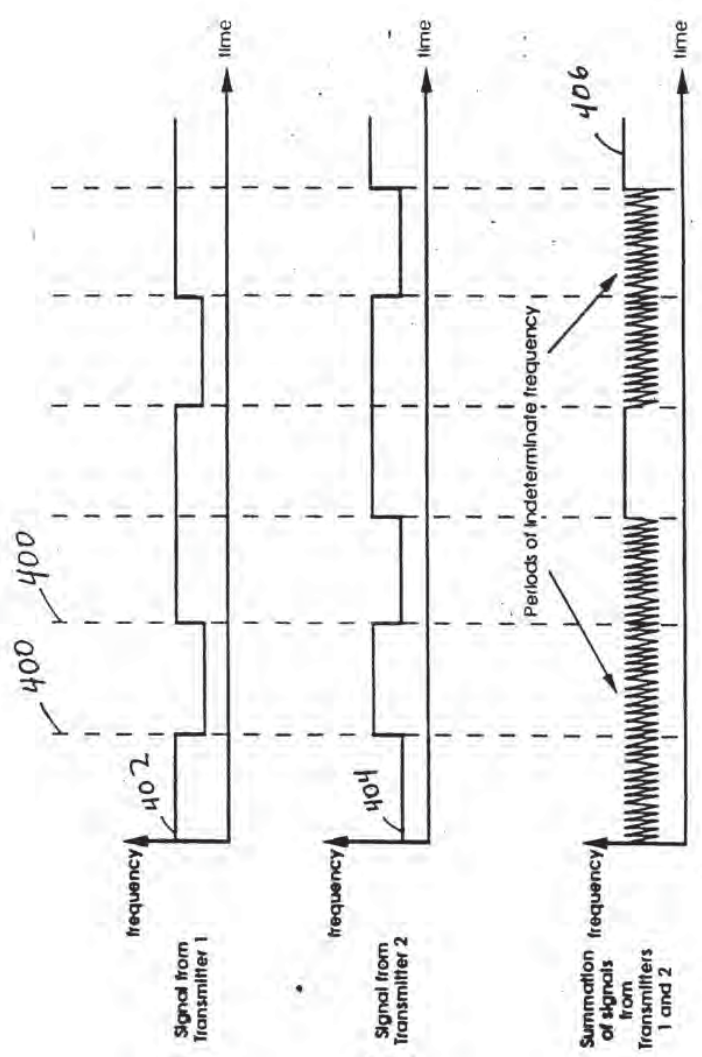
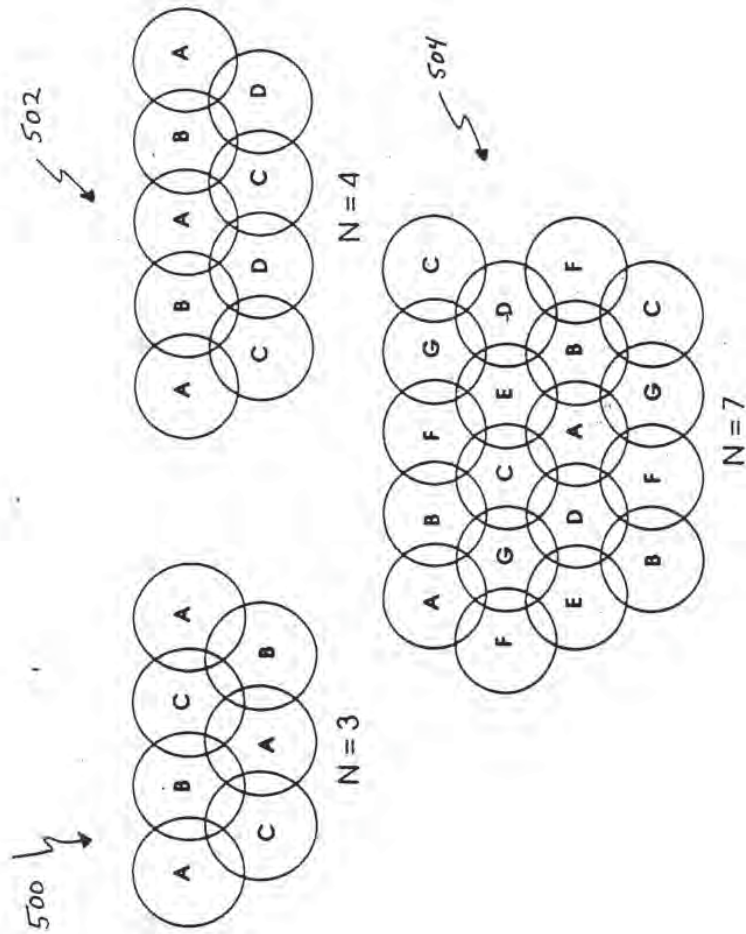

Fig. 4(A)

Fig. 4(B)

Fig. 4(C)

Fig. 4



899496
~~08/700457~~

Fig. 5

899476
08/760457

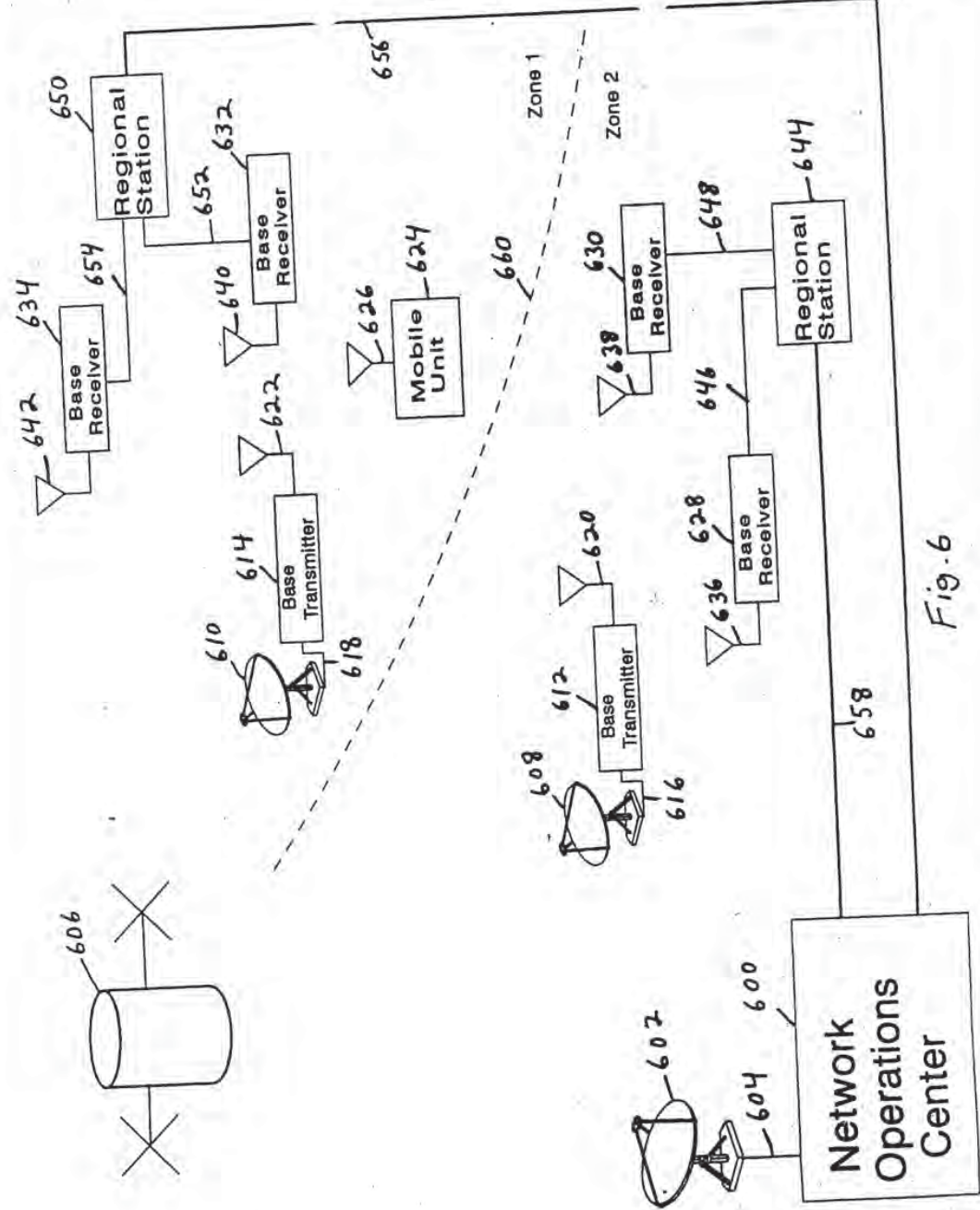

Fig. 6

08/~~760457~~
899,476

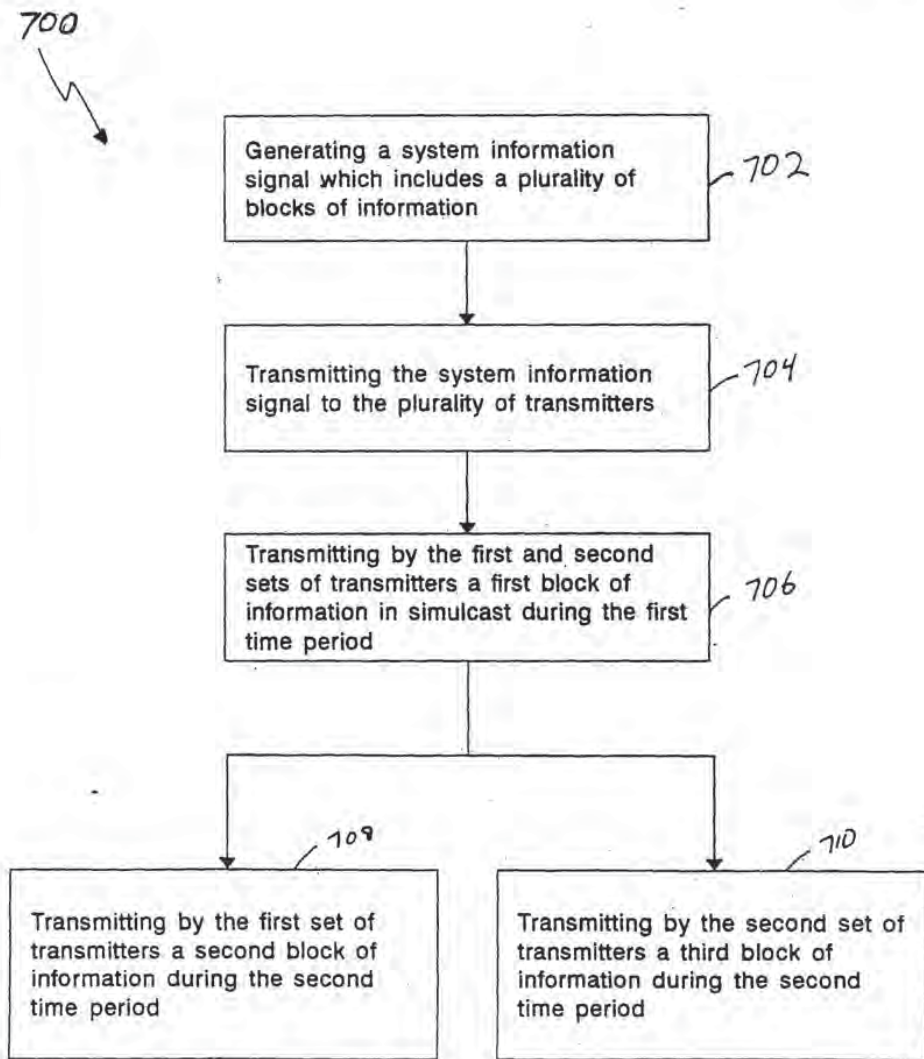

Fig. 7

800

08/760457
899,476
802

Transmitting a message signal by a base transmitter servicing a zone where the mobile transceiver was last known to be located

804

Transmitting a regional probe signal by a plurality of base transmitters servicing a plurality of zones if the mobile transceiver does not indicate receipt of the message signal from the base transmitter

806

Receiving the regional probe signal by the mobile transceiver

808

Transmitting an acknowledgment signal by the mobile transceiver in response to the received regional probe signal

810

Receiving the acknowledgment signal from the mobile transceiver by a base receiver

812

Updating the data to reflect the zone of the base receiver that received the acknowledgment signal as the last known location of the mobile transceiver

Fig. 8

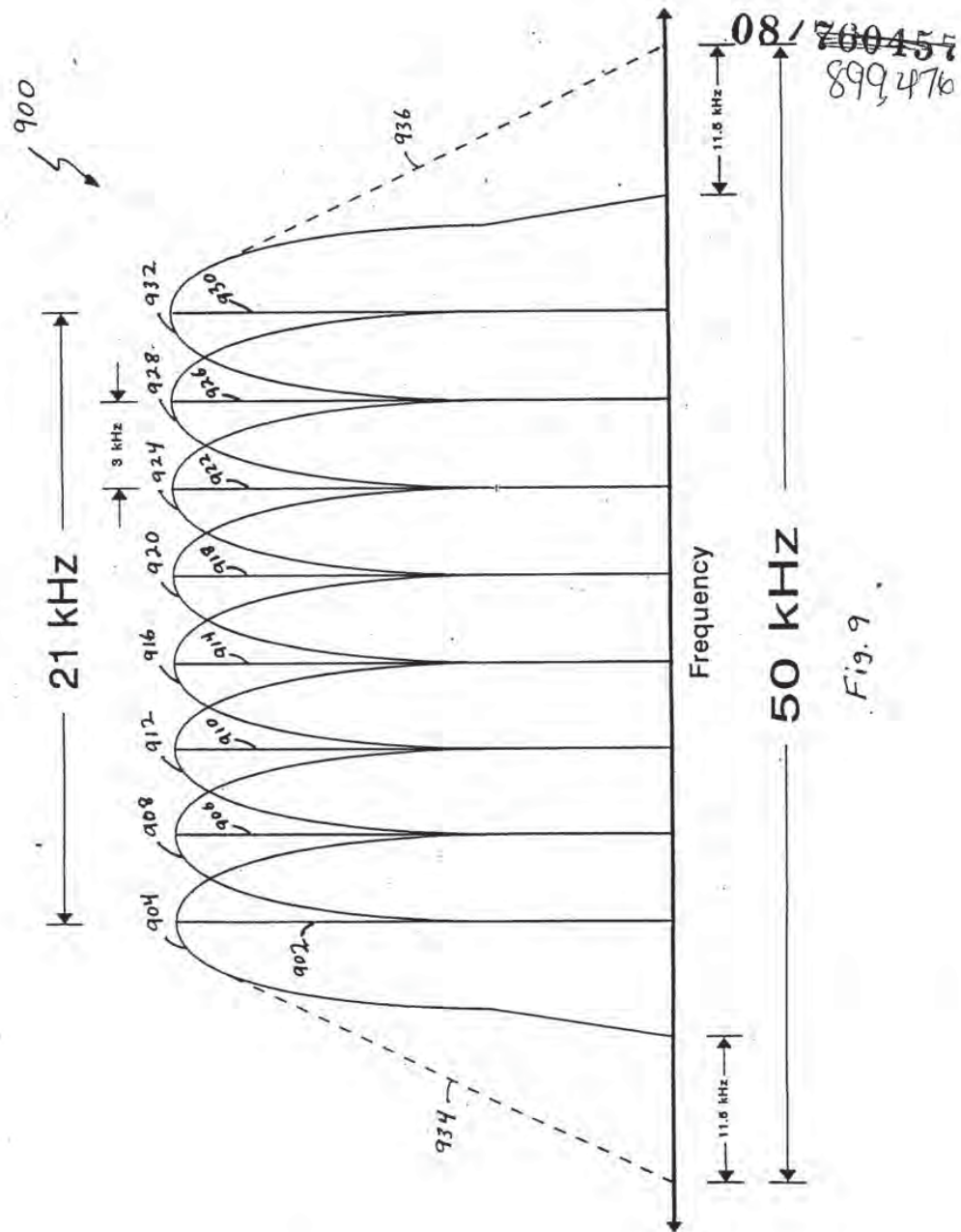

Fig. 9

08/760457
899,476

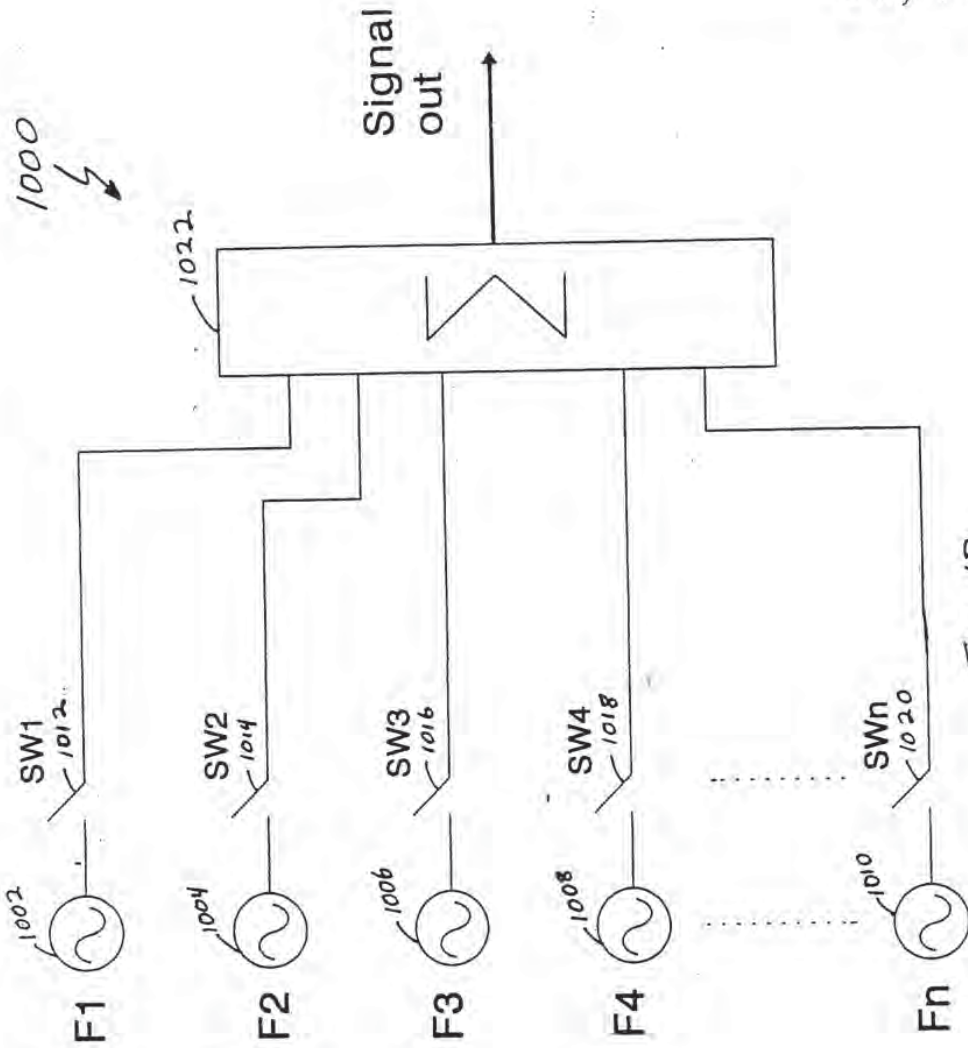

Fig. 10

08/760457
899, 476

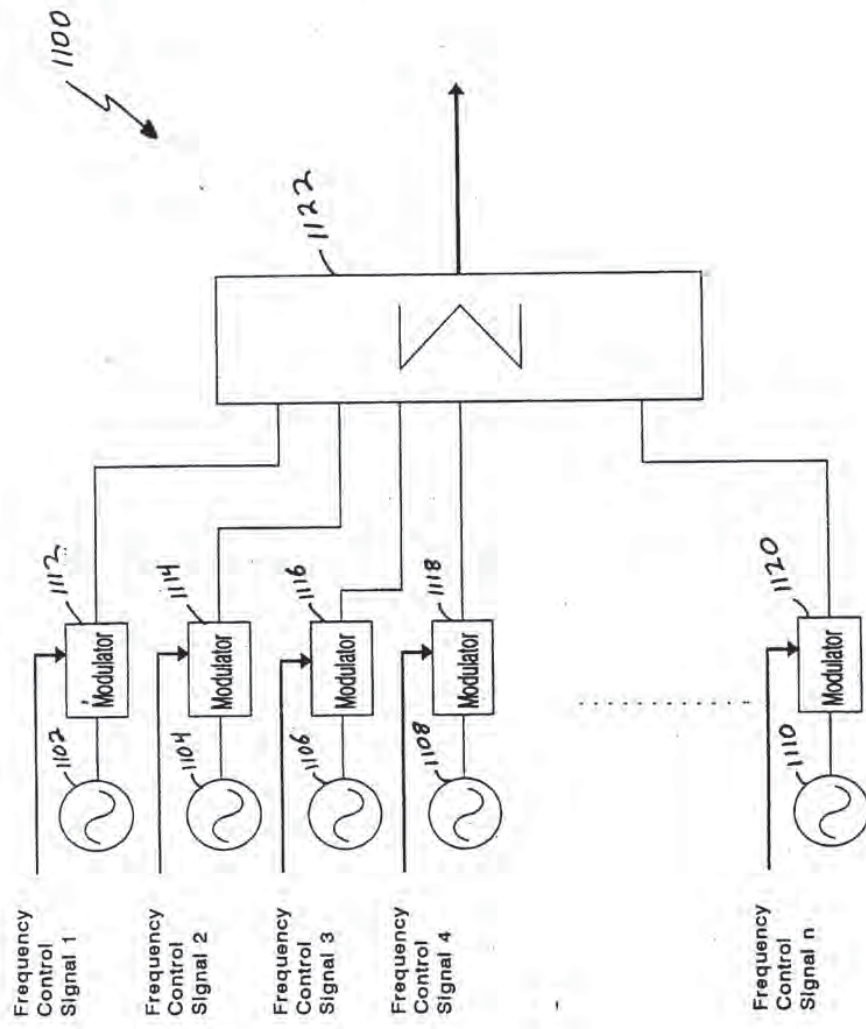
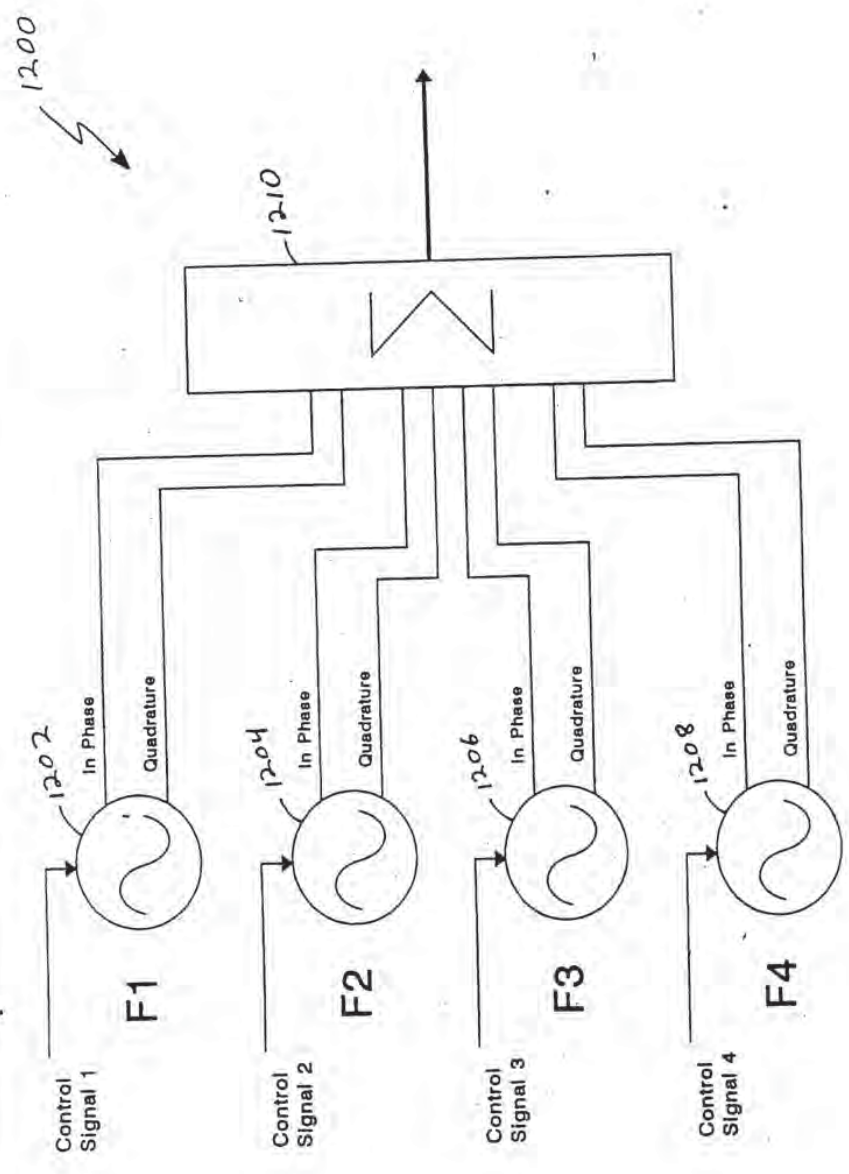

Fig. 11

08/760457
899,476



Four Carrier Quadrature Modulator
Fig. 12

Base Transmitter

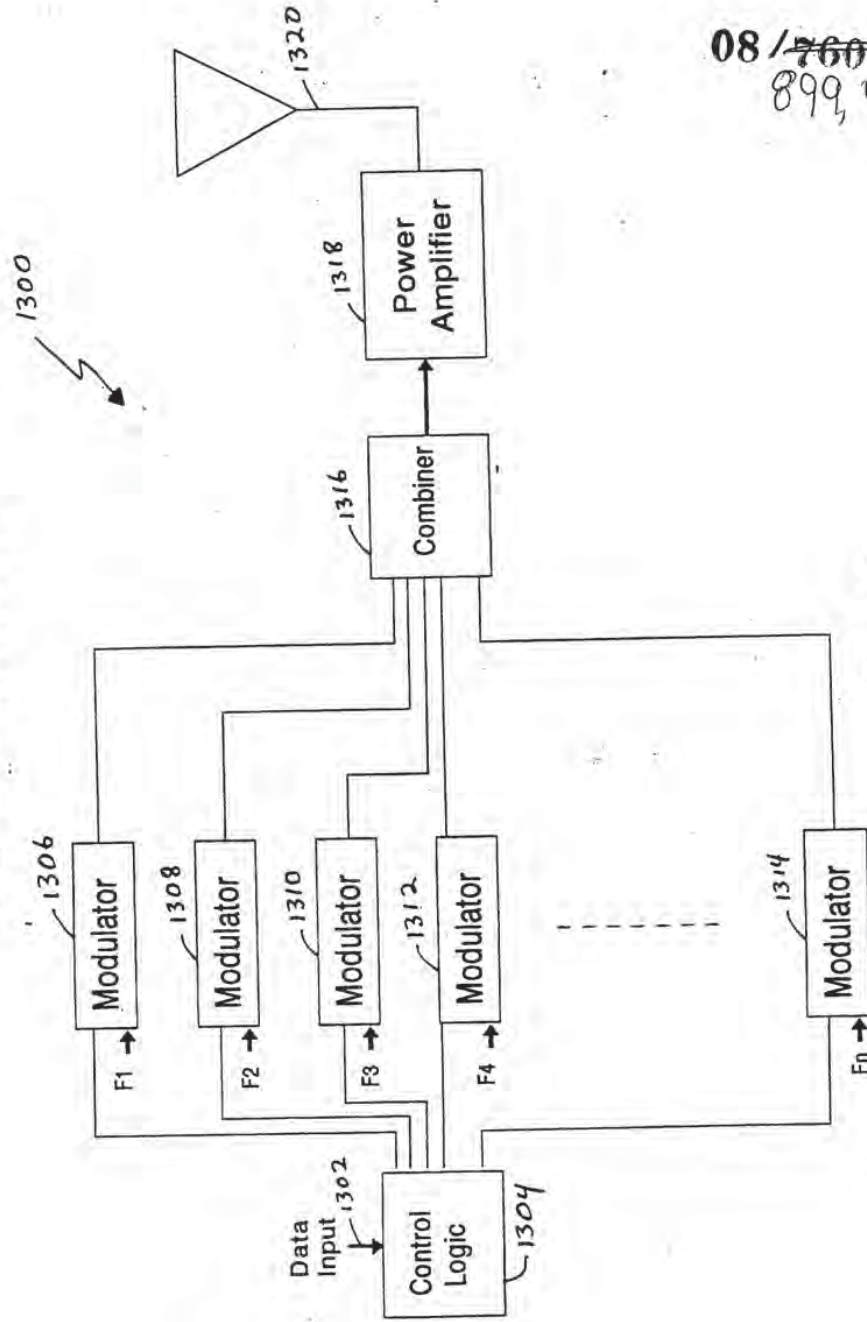

08/760457
899,476

Fig. 13

Base Transmitter

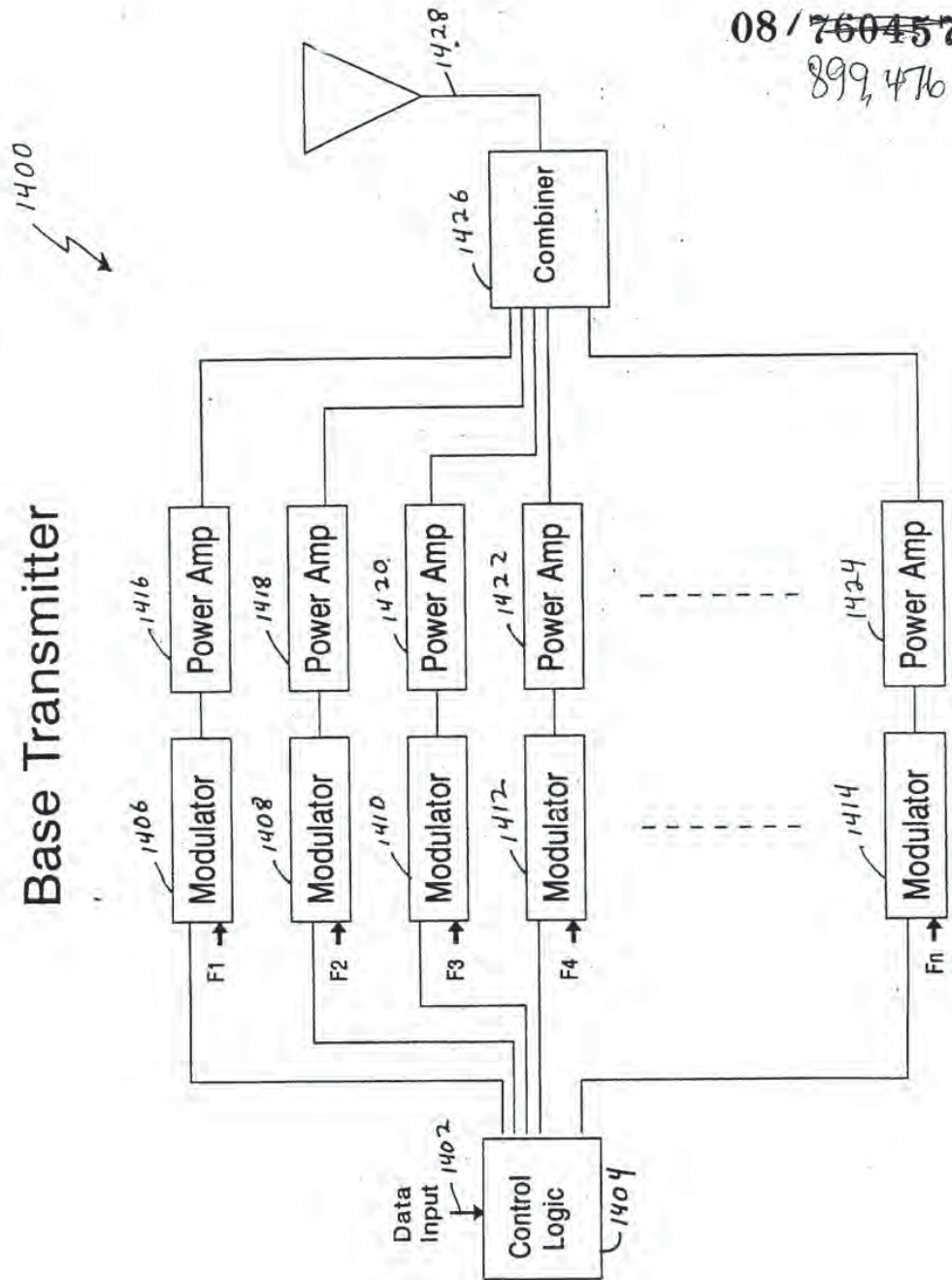

08/760457
899,476

Fig. 14

Mobile Transceiver

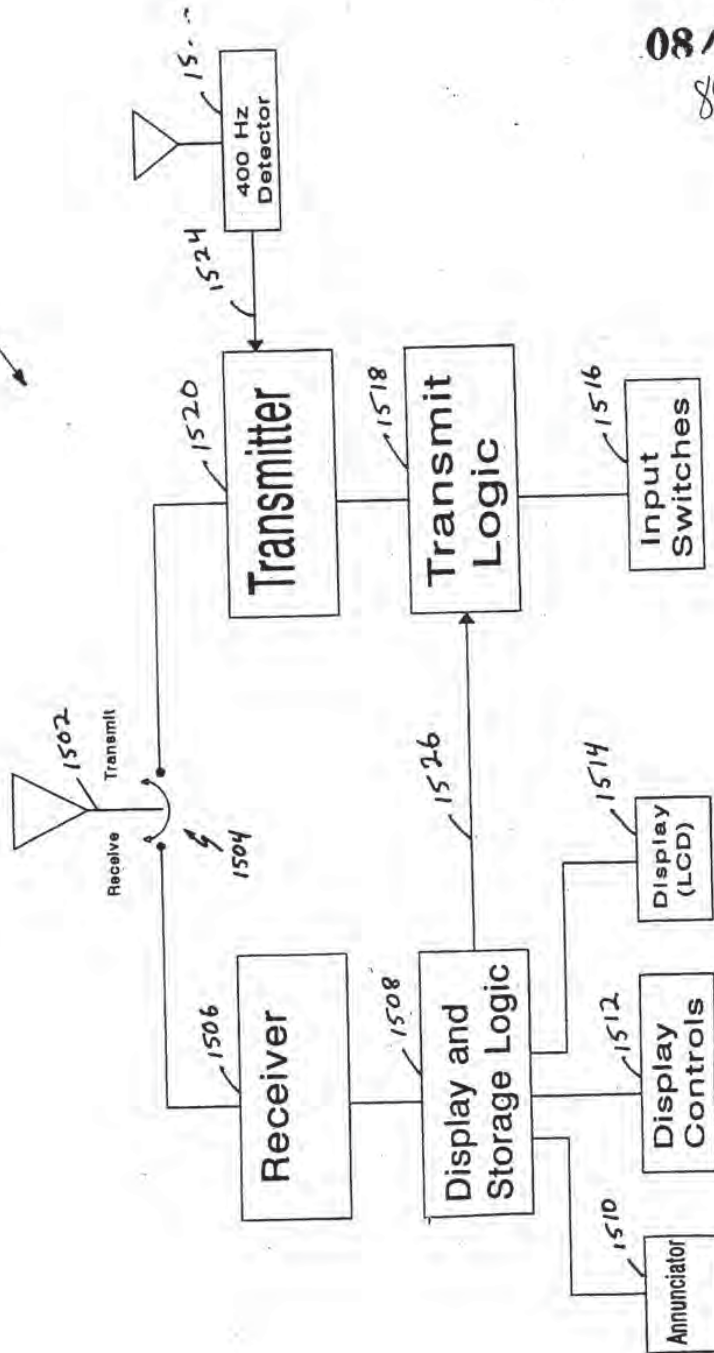

08/260457
899,476

Fig. 15