

UNITED STATES PATENT AND TRADEMARK OFFICE

BEFORE THE PATENT TRIAL AND APPEAL BOARD

APPLE INC.,
Petitioner,

v.

MOBILE TELECOMMUNICATIONS TECHNOLOGIES, LLC,
Patent Owner.

Case IPR2014-01036
Patent 5,915,210

Before MIRIAM L. QUINN, MEREDITH C. PETRAVICK, and
SCOTT A. DANIELS, *Administrative Patent Judges*.

DANIELS, *Administrative Patent Judge*.

DECISION

Decision on Institution of *Inter Partes* Review
37 C.F.R. § 42.108

I. INTRODUCTION

A. Background

Apple Inc. (“Petitioner”) filed a Petition to institute an *inter partes* review of claims 1, 10, and 19 of U.S. Patent No. 5,915,210 (“the ’210 patent”). Paper 6 (“Pet.”). Mobile Telecommunications Technologies, LLC (“Patent Owner”) timely filed Patent Owner’s waiver of its Preliminary Response. Paper 8.

We have authority to determine whether to institute an *inter partes* review under 35 U.S.C. § 314 and 37 C.F.R. § 42.4(a). Upon consideration of the Petition and the Preliminary Response, we determine that Petitioner has established a reasonable likelihood of prevailing on the claims challenged in the Petition. Accordingly, we institute an *inter partes* review of claims 1, 10, and 19 of the ’210 patent.

B. Additional Proceedings

Petitioner states that the ’210 patent presently is asserted against Petitioner in *Mobile Telecommunications Technologies, LLC v. Apple Inc.*, Case No. 2:13-CV-258 in the U. S. District Court for the Eastern District of Texas (hereinafter “the Apple lawsuit”). Pet. 1. Petitioner also notes that the ’210 patent is asserted against other parties in *Mobile Telecommunications Technologies, LLC v. Sprint Nextel Corp.*, Case No. 2:12-CV-832 (E.D. Tex.); *Mobile Telecommunications Technologies, LLC v. Leap Wireless International, Inc.*, Case No. 2-13-CV-885 (E.D. Tex.); *Mobile Telecommunications Technologies, LLC v. T-Mobile USA, Inc.*, Case No. 2-13-CV-886 (E.D. Tex.); and *Mobile Telecommunications Technologies, LLC v. Samsung Telecommunications America, LLC*, Case No. 2:13-CV-259, all in the Eastern District of Texas. *Id.*

C. The '210 Patent

The '210 patent (Ex. 1001), titled “Method and System for Providing Multicarrier Simulcast Transmission,” describes a system for two-way communication between a network operations center and a mobile device located somewhere in a wide geographic region. Ex. 1001, Abstract. The '210 patent explains that an important aspect of the invention is to “provide a communication system with wide area coverage and high message throughput while minimizing frequency bandwidth usage.” *Id.* at 4:46–48.

Figure 6 of the '210 patent, reproduced below, illustrates the major components of the communication system for sending a data signal between networks operation center 600 and mobile unit 624. *Id.* at 8:46–48.

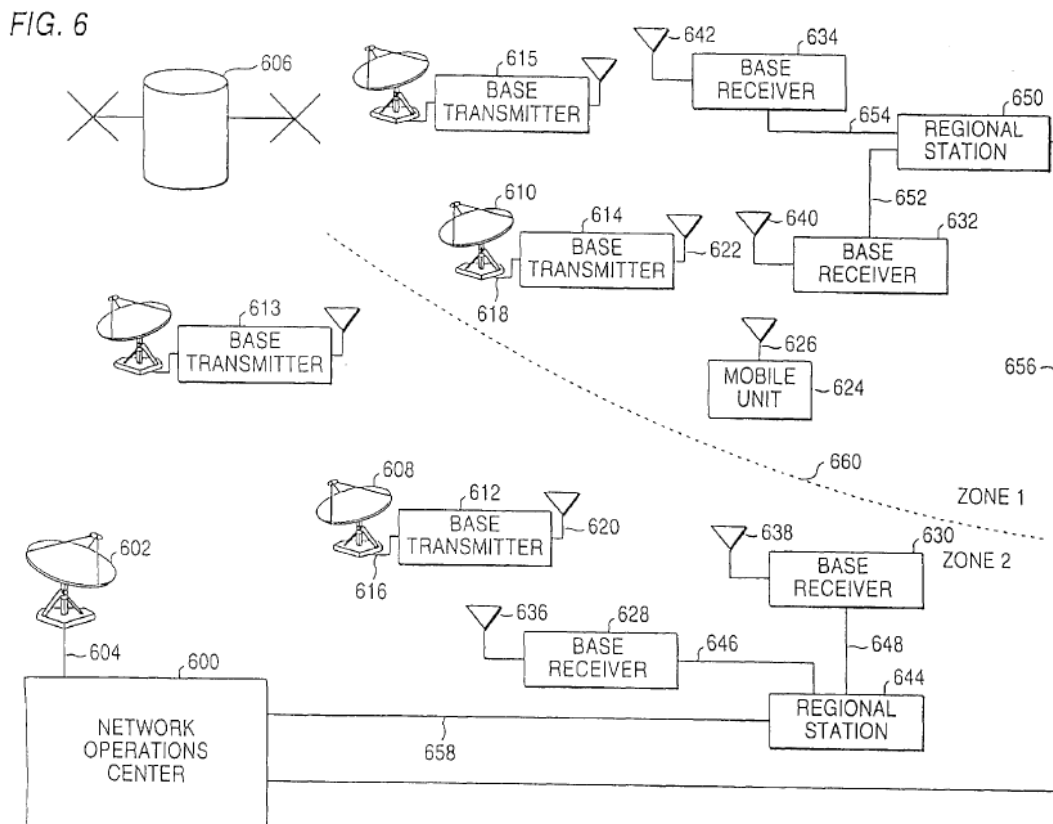

Figure 6 is a schematic diagram of a communication system.

As depicted by Figure 6 of the '210 patent, above, the communication system provides network operations center 600 connected to satellite uplink 602, which in turn, provides data to satellite 606. *Id.* at 8:48–51. Satellite 606 communicates the received data to several satellite downlink stations 608, 610. *Id.* at 8:52–53. Satellite downlink stations 608, 610 send the data signal to geographically spaced apart base transmitters 612, 614 which emit the signal via antennas 620 and 622, respectively, in different geographic defined regions, i.e., “zones,” for reception by mobile unit 624. *Id.* at 8:62–9:5. Dash line 660 indicates the boundary between zones 1 and 2, and each zone may include additional base transmitters 613, 615, respectively, as shown in Figure 6. *Id.* at 8:62–9:56. Mobile unit 624, shown in zone 1, is a portable communication device, for instance, a pager, and can both receive and transmit a signal. *Id.* at 9:6–11.

The written description explains that dash line 660 is only an approximate boundary because each zone actually has its own boundary, and the boundaries of adjacent zones overlap with one another. *Id.* at 9:46–56. Such an “overlap area” between zones as known in the prior art, is best shown by boundaries 202 and 204 in Figure 2 of the '210 patent. *Id.* at 9:57–65. Figure 2 is reproduced below:

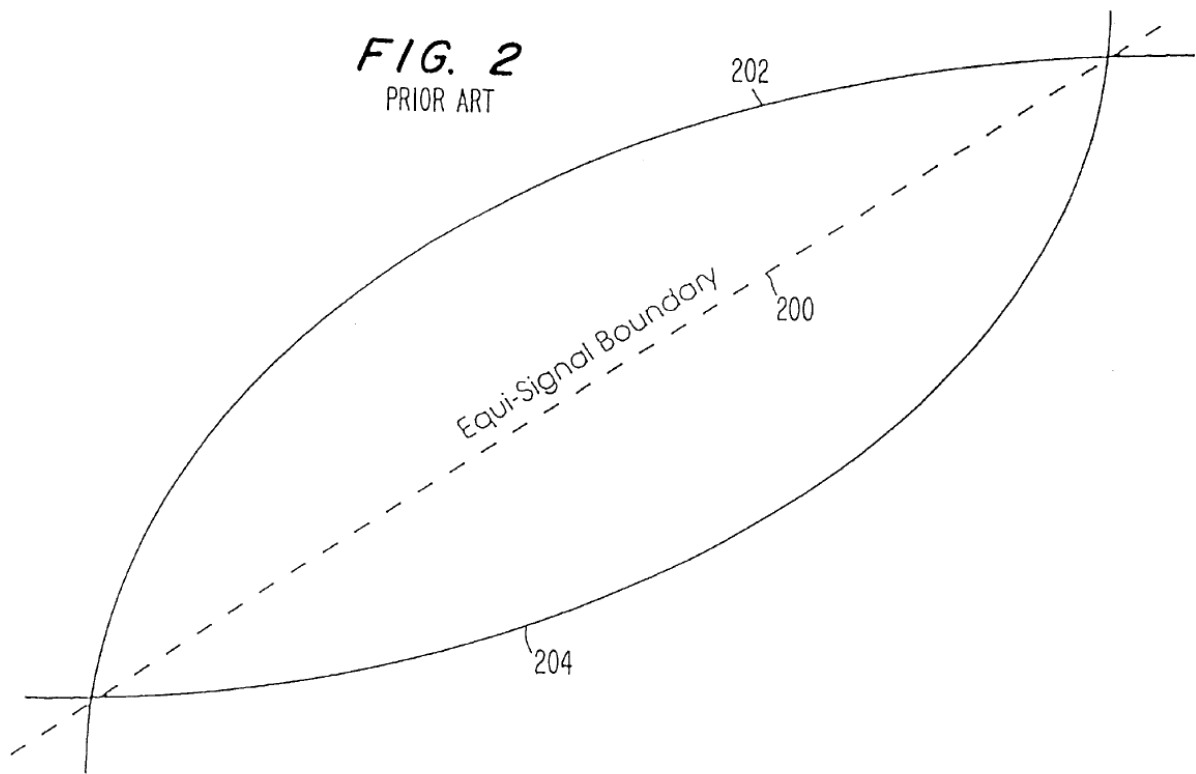

Figure 2 is a schematic diagram of uniform smooth earth propagation.

As depicted by Figure 2 of the '210 patent, curved boundaries 202 and 204 define an overlap area and equi-signal boundary 200. *Id.* at 9:59–61.

Keeping Figure 6 of the '210 patent in mind, in one embodiment of the invention, base transmitters 612, 614 receive a data signal from satellite 606 via down link stations 608, 610, and then transmit the same data signal at the same time, i.e., in simulcast, in both zones 1 and 2, to be received by mobile unit 624. *Id.* at 10:35–41. The '210 patent explains that this method is “useful to deliver the message if, for example, the location of mobile unit 624 in zone 1 or zone 2 is *unknown* and broad coverage is desired.” *Id.* at 10:41–44 (emphasis added). In another embodiment, if for instance the location of mobile unit 624 is *known* to be in zone 1, base transmitter 614 transmits a data signal within zone 1, and at the same time, base transmitter

Explore Litigation Insights

Docket Alarm provides insights to develop a more informed litigation strategy and the peace of mind of knowing you're on top of things.

Real-Time Litigation Alerts



Keep your litigation team up-to-date with **real-time alerts** and advanced team management tools built for the enterprise, all while greatly reducing PACER spend.

Our comprehensive service means we can handle Federal, State, and Administrative courts across the country.

Advanced Docket Research



With over 230 million records, Docket Alarm's cloud-native docket research platform finds what other services can't. Coverage includes Federal, State, plus PTAB, TTAB, ITC and NLRB decisions, all in one place.

Identify arguments that have been successful in the past with full text, pinpoint searching. Link to case law cited within any court document via Fastcase.

Analytics At Your Fingertips



Learn what happened the last time a particular judge, opposing counsel or company faced cases similar to yours.

Advanced out-of-the-box PTAB and TTAB analytics are always at your fingertips.

API

Docket Alarm offers a powerful API (application programming interface) to developers that want to integrate case filings into their apps.

LAW FIRMS

Build custom dashboards for your attorneys and clients with live data direct from the court.

Automate many repetitive legal tasks like conflict checks, document management, and marketing.

FINANCIAL INSTITUTIONS

Litigation and bankruptcy checks for companies and debtors.

E-DISCOVERY AND LEGAL VENDORS

Sync your system to PACER to automate legal marketing.