

June 18, 1963

I. J. McCULLOUGH  
POWER TOOL

3,094,166

Filed July 25, 1960

2 Sheets-Sheet 1

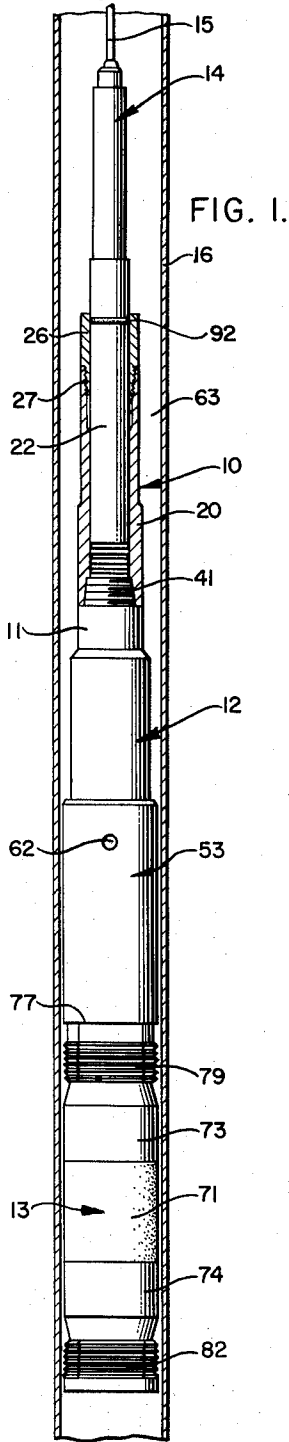

FIG. 1.

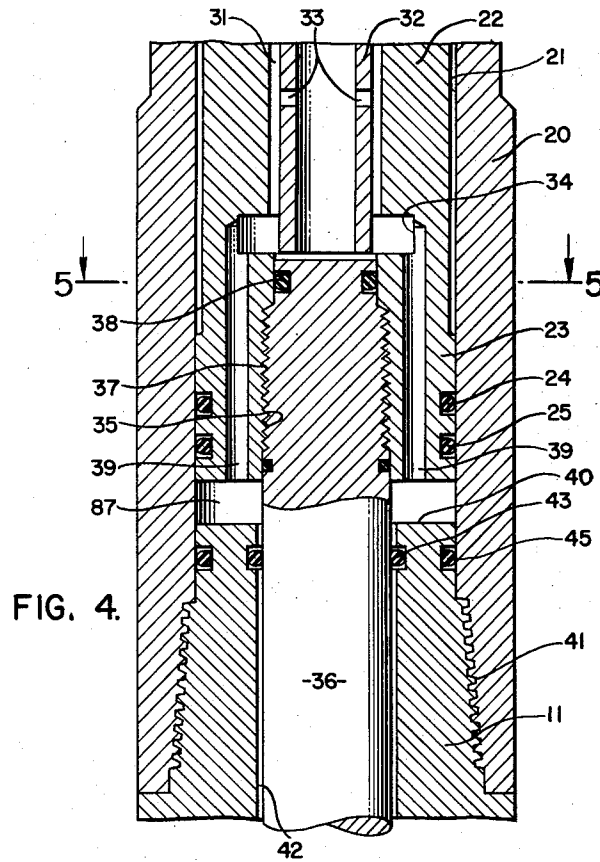

FIG. 4.

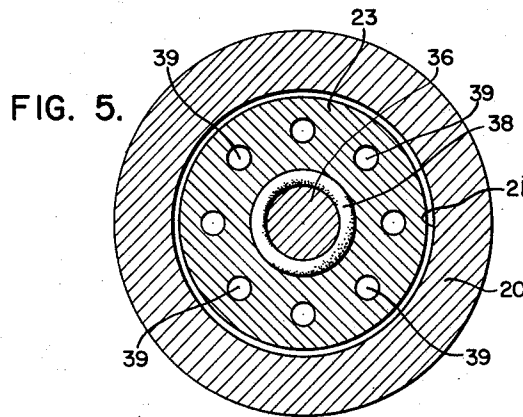

FIG. 5.

INVENTOR  
IRA J. McCULLOUGH  
BY *Lyon Lyon*  
ATTORNEYS

June 18, 1963

I. J. McCULLOUGH

3,094,166

POWER TOOL

Filed July 25, 1960

2 Sheets-Sheet 2

FIG. 2.

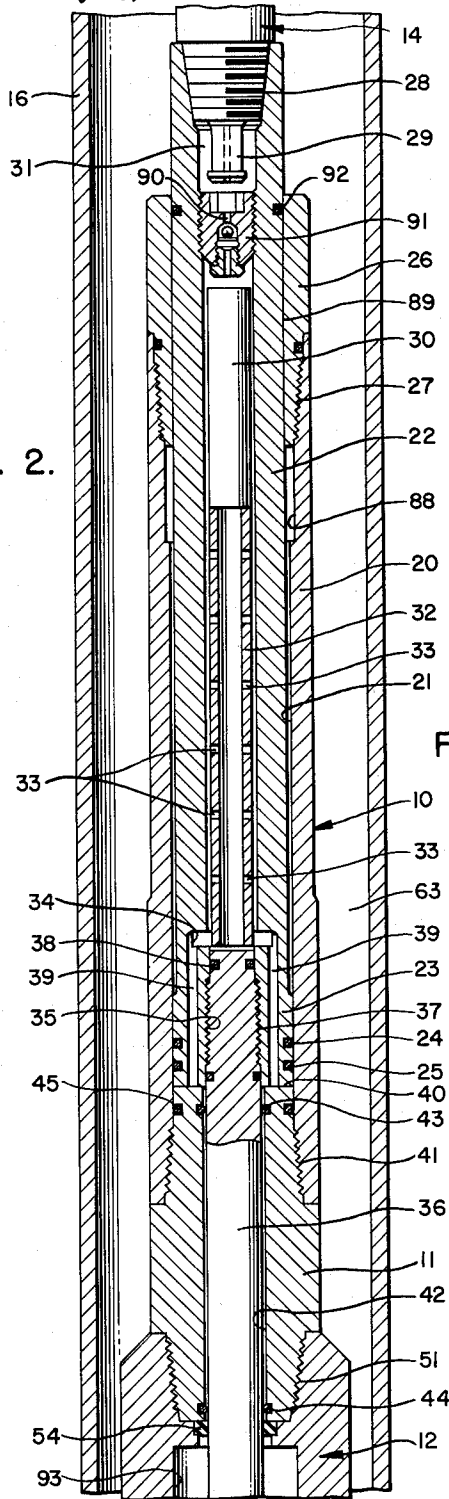
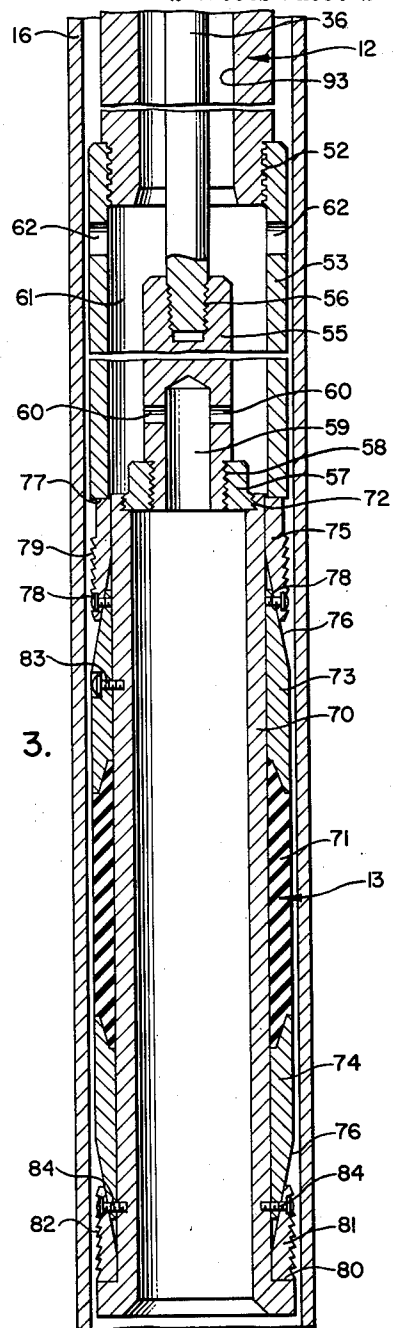

FIG. 3.



INVENTOR.  
IRA J. McCULLOUGH  
BY *Lyon Lyon*  
ATTORNEYS

1

**3,094,166  
POWER TOOL**

Ira J. McCullough, Los Angeles, Calif. (% McCullough Tool Co., 5820 S. Alameda St., Vernon, Calif.)  
Filed July 25, 1960, Ser. No. 45,124  
4 Claims. (Cl. 166-63)

This invention relates to well tools and is particularly directed to improvements in a power device for setting a well tool such as a packer or a bridge plug.

It is an object of this invention to provide an improved form of power device which may be triggered to develop internal pressure and cause relative movement between a piston and a cylinder in order to perform useful work on an adjacent well tool. Another object is to provide such a device in which the gas generating charge is confined within the inner of two concentric parts having relative longitudinal movement. Another object is to provide a power tool that pulls or contracts into itself as opposed to pushing the parts away from each other. Another object is to provide a power tool that incorporates a piston which has a power charge arranged within itself whereby upon release of the gas pressure out of the piston, a piston rod is drawn into the cylinder which contains the piston. Another object is to provide a power actuating device for a well tool in which the inner part moves upward with respect to the outer part, thereby eliminating the conventional cross-over apparatus which is necessary for operating a packer or a bridge plug from a setting tool in which the inner part moves downward relative to the outer part. Another object is to provide such a device in which the gas pressure is generated within the piston and released into its surrounding cylinder to move the piston relative to the cylinder. Another object is to provide such a device in which the gas pressure generated within the piston, upon release into the cylinder moves the piston and pulls the piston rod into the cylinder. Other and more detailed objects and advantages will appear hereinafter.

In the drawings:

FIGURE 1 is a side elevation, partly in section, showing a preferred embodiment of this invention.

FIGURE 2 is a sectional elevation of a portion of the apparatus shown on a larger scale.

FIGURE 3 is a sectional elevation constituting a continuation of the lower end of FIGURE 2, shown on a smaller scale.

FIGURE 4 is a sectional elevation of a portion of the apparatus shown in FIGURE 2.

FIGURE 5 is a transverse sectional view taken substantially on the lines 5-5 as shown on FIGURE 4.

Referring to the drawings, the power device generally designated 10 is shown attached through a lower cylinder sub 12 and adapter 53 to a packer assembly 13. At the upper end of the power device 10, there is provided a rope socket 14 which is suspended from a wire line 15, or from a string of pipe, not shown. The wire line 15, or the string of pipe, is used to lower the power device 10 into the well, carrying a tool to be set in a well, such as packer device 13. In the general plan of operation the power device, or power tool, is used to lower a tool such as a packer device 13, to the desired position within the well and then the power tool is operated to set the packer 13 within a well casing 16.

The power device 10 includes a cylinder member 20 having an axially extending bore 21. A piston 22 is positioned within the cylinder 20 and is provided with an enlarged portion near the lower end thereof which comprises a piston head 23 slidably mounted within the bore 21. O rings 24 and 25 are mounted on the piston head 23 and have sealing engagement within the bore

2

guide nut 26. This guide nut is attached to the upper end of the cylinder 20 by means of threads 27. The upper end of the piston 22 is connected by threads 28 to a conventional electric rope socket 14. The bottom end of rope socket 14 carries an igniter assembly 29 which may be of conventional form. It is electrically operated from the cable 15 for igniting a gas generating charge 30 mounted within the central cavity 31 within the top end of piston 22. A spacer tube 32 also within the cavity 31 serves to support the gas generating charge 30 in the upper end of the cavity 31, adjacent to igniter assembly 29. The spacer tube 32 has a plurality of apertures 33 in the wall thereof to allow force distribution of generated gas pressure.

An internal chamber enlargement 34 is provided at the lower end of the cavity 31 in the piston 22 and a threaded socket 35 is provided in the piston 22 below this internal enlargement 34. The piston rod 36 having external threads 37 is threaded into the socket 35 and a seal ring 38 is provided adjacent the upper end of the piston rod 36 to prevent leakage along the threads 37. A plurality of longitudinal ports 39 extend from the enlargement 34 to the lower end of the piston 22. When the power tool is assembled ready for operation the bottom end of piston 22 rests on the top end of upper cylinder sub 11, as shown at 40. When the gas generating charge 30 is ignited in piston 22 the gas pressure will pass into chamber 34, through ports 39 and out the bottom end of piston 22, causing the piston to lift off the seat 40. The pressure in the expansion chamber 87 moves the piston upwardly in relation to cylinder 20, thereby pulling piston rod 36 into cylinder 20.

The upper cylinder sub 11 is attached to the lower end of the cylinder 20. Threads 41 connect the parts 20 and 11. The cylinder sub 11 has a central opening 42 which slidably receives the piston rod 36. Seal rings 43 and 44 on the part 11 engage the piston rod 36 and a seal ring 45 on the part 11 engages the bore 21 in the lower end of the cylinder 20 to prevent leakage along the threads 41.

A bottom cylinder sub 12 is attached to the lower end of the upper cylinder sub 11 by means of the threads 51. Threads 52 at the lower end of the cylinder sub 12 form a connection with an adapter 53. A wiper ring 54 formed of resilient material is clamped between the cylinder sub 11 and the sub 12 and engages the outer surface of the piston rod 36 in wiping contact.

A tension part of piston rod connector 55 is attached to the lower end of the piston rod 36 by means of the threads 56. A release ring 57 is secured by threads 58 to the lower end of the connector part 55. An axial opening 59 and lateral ports 60 in the part 55 provide a fluid bypass from the space below the part 55 into the annular space 61 in adapter 53. Fluid outlets 62 in the wall of the adapter 53 near the upper end thereof lead from the annular space 61 into the annular space 63 between the power tool 10 and the interior of the casing 16.

A conventional packer device 13 may be provided with a tubular body or mandrel 70, and a rubber packing sleeve 71 is mounted on the outer surface of this mandrel 70. Shear threads 72 connect the upper end of the mandrel 70 to the release ring 57 on the lower end of the connector part 55. Metal sleeves 73 and 74 are slidably mounted on the outer surface of the mandrel 70 and each is provided with a tapered conical portion 76. An upper set of slips 75 is mounted on the mandrel for cooperation with the sleeve 73 in contact with the tapered surface 76. An abutment 77 on the lower end of the adapter 53 engages the upper set of slips 75. A series of shear screws 78 connect the slips 75 to the sleeve 73 on the mandrel 70.

engaging the inner surface of the casing 16. Shear screws 83 resist movement of the sleeve 73 on the mandrel 70. The lower end of the mandrel 70 is provided with a shoulder 80 which supports the slips 81. Wickers 82 on the slips 81 are adapted to engage the inner surface of the casing 16. Shear screws 84 resist movement of the sleeve 74 on the mandrel 70, as well as resisting movement of the slips 81.

The packer device 13 is operated by applying a force moving the mandrel 70 upward relative to the slips 75. The relative strength of the shear screws 78, 83 and 84 is such that the following events occur: (a) the shear screws 83 fail, allowing the mandrel 70 to move upward relative to sleeve 73; (b) the shear screws 78 fail causing the cone surface 76 to move the upper slip 75 into engagement with the inner surface of the casing 16, and causing the sleeve 76 to apply an axial force to the rubber packing sleeve 71; (c) the shear screws 84 fail causing the lower slips 81 to move outward into engagement with the inner surface of the casing 16, further compressing the rubber packing sleeve 71, and (d) the shear threads 72 fail, thereby separating the power tool device 10 from the packer device 13.

Shearing of the screws 78, 83 and 84 and failure of the shear threads 72 occur in very rapid sequence, as the gas pressure developed by the charge 30 passes into the expansion chamber 87 between the lower end of the piston 22 and the upper end of the element 11. As the piston completes its upward stroke relative to the cylinder 20, the O rings 24 and 25 on the piston 22 pass the enlarged bore 88 of the cylinder 20. Gas pressure in the cavity 31 and expansion chamber 87 is then vented through the clearance 39 out into the interior of the well casing 16. The sealing ring 92 on the upper end of piston 22 forms a temporary seal on the inside of guide nut 26. It thus keeps mud and debris out of the tool while being lowered into the well. The seal is removed as soon as the piston moves a short distance which permits the gases to be vented at the end of the power stroke as stated above.

Means are provided for arresting upward motion of the piston 22 and piston rod 36 with respect to the cylinder 20, after the packer device 13 has been set and released. As shown in the drawings, this means includes a bore 93 in the bottom cylinder sub 12 which is adapted to receive the tension part or connector rod 55 in close fitting relationship. The bore 93 may initially contain heavy grease or other sealing plastic non-metallic material to cushion deceleration of the parts 22 and 36 with respect to the cylinder member 20. The wiper ring 54 serves to prevent this grease or other material from being drawn into the expansion chamber 87 through the bore 42.

In operation, the power device or power tool 10 is lowered into a well casing 16 on the end of a pipe string (not shown) or on a wire line 15. The igniter assembly 29 forms the upper end of the tool 10 and on the lower end thereof may be attached a tool or other device which needs power to actuate same, such as is shown by the packer device 13. As the setting tool 10 and packer device 13 pass downward through the interior of the casing 16 any liquid in the casing passes upward through the interior of the hollow mandrel 70 and through the fluid passage 59, 60 into the annular space 61 and then out through fluid outlet 62 into the interior of the casing 16. This provides a fluid bypass to facilitate lowering the setting tool 10 and the packer device 13 to the desired position in the well.

When the setting tool 10 and packer device 13 have reached the desired position in the well, the igniter assembly 29 is energized by means of an electrical conductor (not shown) within the wire line 15. The igniter assembly 29 is conventional and serves to pass hot gases downward through the opening 90 in the check valve 91 at the upper end of the cavity 31 in the tubular member 22. A jet of hot gas is impinged directly on the upper end of the gas generating charge 30 causing it to ignite.

As the charge burns, pressure within the cavity 31 increases very rapidly and the check valve 91 closes to prevent damage to the rope socket assembly. This pressure passes through the internal enlargement 34 and through the longitudinal ports 39 into the expansion chamber 87. The pressure in the chamber 87 causes rapid upward movement of the piston 22 relative to the cylinder 20. As set forth in detail above this relative motion serves to set the packer device 13 and to disconnect the setting tool 10 therefrom. The setting tool may then be withdrawn from the well by means of the wire line 15, leaving the packer device 13 remaining in the well.

Having fully described my invention, it is to be understood that I do not wish to be limited to the details set forth herein, but my invention is of the full scope of the appended claims.

I claim:

1. In a power device for a well tool, the combination of: a cylinder member, a tubular member having a central cavity and serving as a piston slidably mounted in sealing relation with said cylinder member, a gas generating charge in said cavity, an igniter assembly fixed to said tubular member for igniting said charge, a piston rod connected to said tubular member, said cylinder member having an element thereon provided with a central opening forming a sliding seal with said piston rod, said members cooperating to form an expansion chamber between said piston and said element, said tubular member having an internal enlargement at the lower end of said cavity and having ports therein connecting said internal enlargement with said expansion chamber, whereby gas generated by said charge in said cavity passes through said enlargement and said ports into said expansion chamber to cause relative movement of said piston rod into said cylinder member.

2. In a power device for a well tool, the combination of: a cylinder member having a bore, a tubular member having a central cavity and provided with a piston slidably mounted in sealing relation within said bore, the tubular member having a threaded socket at the lower end of the cavity, a gas generating charge in said cavity, an igniter assembly fixed to the upper end of said tubular member for igniting said charge, suspension means for supporting the igniter assembly whereby the power actuator device may be lowered into a well, a piston rod having an upper end threadedly received in said socket, said cylinder member having an element fixed thereto provided with a central opening forming a sliding seal with said piston rod, means on said piston rod and on said cylinder member for establishing force-transmitting connections to a well tool, said tubular member having an internal enlargement at the lower end of said cavity and having ports therein connecting said internal enlargement with the interior of said bore below said piston, whereby gas generated by said charge in said cavity passes through said enlargement and said ports to cause relative upward movement of said piston rod into said cylinder member to actuate the well tool.

3. In a power device for a well tool, the combination of: a cylinder member having a bore, a tubular member having a central cavity and provided with a piston slidably mounted in sealing relation within said bore, the tubular member having a threaded socket at the lower end of the cavity, a gas generating charge in said cavity, an igniter assembly fixed to the upper end of said tubular member for igniting said charge, a piston rod having an upper end threadedly received in said socket, said cylinder member having an element fixed thereto provided with a central opening forming a sliding seal with said piston rod, said members cooperating to form an expansion chamber between said piston and said element, said tubular member having an internal enlargement at the lower end of said cavity and having ports connecting said internal enlargement with said expansion chamber, whereby gas generated by said charge in said cavity passes

5

through said enlargement and said ports into said expansion chamber to cause relative upward movement of said piston rod into said cylinder member.

4. In a power device for well tools, the combination of: a cylinder member having a bore, a tubular member having a central cavity and provided with a piston slidably mounted within said bore, at least one sealing ring on the piston slidably engaging said bore to form a seal, a gas generating charge in said cavity, an igniter device for igniting said charge, a piston rod connected to said tubular member, said cylinder member having an element thereon provided with a central opening forming a sliding seal with said piston rod, said members cooperat-

6

ing to form an expansion chamber between said piston and said element, port means in said tubular member for connecting said cavity with said expansion chamber, and means within the bore of said cylinder member cooperating with said seal ring at a location near the end of the relative sliding movement of said piston rod and said cylinder member to destroy its sealing effect and to vent said expansion chamber.

References Cited in the file of this patent

UNITED STATES PATENTS

2,692,023	Conrad	Oct. 19, 1954
2,951,539	Malone et al.	Sept. 6, 1960