



US008459346B2

(12) **United States Patent**  
**Frazier**

(10) **Patent No.:** **US 8,459,346 B2**  
(45) **Date of Patent:** **\*Jun. 11, 2013**

(54) **BOTTOM SET DOWNHOLE PLUG**

(75) Inventor: **W. Lynn Frazier**, Corpus Christi, TX (US)

(73) Assignee: **Magnum Oil Tools International Ltd.**, Corpus Christi, TX (US)

(\* ) Notice: Subject to any disclaimer, the term of this patent is extended or adjusted under 35 U.S.C. 154(b) by 0 days.

This patent is subject to a terminal disclaimer.

(21) Appl. No.: **13/329,077**

(22) Filed: **Dec. 16, 2011**

(65) **Prior Publication Data**

US 2012/0145378 A1 Jun. 14, 2012

**Related U.S. Application Data**

(63) Continuation of application No. 13/194,871, filed on Jul. 29, 2011, now Pat. No. 8,079,413, which is a continuation-in-part of application No. 12/317,497, filed on Dec. 23, 2008.

(51) **Int. Cl.**  
*E21B 33/129* (2006.01)  
*E21B 23/06* (2006.01)

(52) **U.S. Cl.**  
USPC ..... **166/124**; 166/135

(58) **Field of Classification Search**  
USPC ..... 166/123, 124, 135, 138  
See application file for complete search history.

(56) **References Cited**

**U.S. PATENT DOCUMENTS**

RE17,217 E 2/1929 Burch  
2,040,889 A 5/1933 Whinnen  
2,223,602 A 10/1938 Cox

2,160,228 A 5/1939 Pustmueller  
2,286,126 A 7/1940 Thornhill  
2,230,447 A \* 2/1941 Bassinger ..... 166/128  
2,331,532 A \* 10/1943 Bassinger ..... 166/139  
2,376,605 A 5/1945 Lawrence

(Continued)

**FOREIGN PATENT DOCUMENTS**

GB 914030 12/1962  
WO 2010127457 11/2010

**OTHER PUBLICATIONS**

“Teledyne Merla Oil Tools-Products-Services,” Teledyne Merla, Aug. 1990 (40 Pages).

(Continued)

*Primary Examiner* — Shane Bomar

*Assistant Examiner* — Robert E Fuller

(74) *Attorney, Agent, or Firm* — Edmonds & Nolte, P.C.

(57) **ABSTRACT**

A plug for isolating a wellbore. The plug can include a body having a first end and a second end, wherein the body is formed from one or more composite materials and adapted to receive a setting tool through the first end thereof, at least one malleable element disposed about the body, at least one slip disposed about the body, at least one conical member disposed about the body, and one or more shearable threads disposed on an inner surface of the body, adjacent the second end thereof, wherein the one or more shearable threads are adapted to receive at least a portion of a setting tool that enters the body through the first end thereof, and wherein the one or more shearable threads are adapted to engage the setting tool when disposed through the body and adapted to release the setting tool when exposed to a predetermined axial force.

**38 Claims, 7 Drawing Sheets**

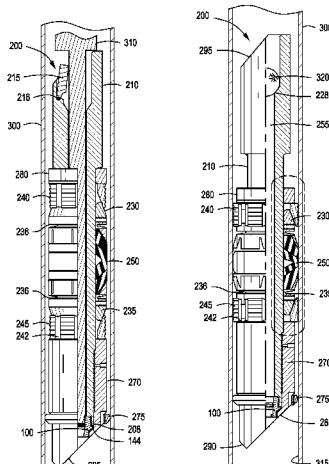

U.S. PATENT DOCUMENTS					
2,593,520	A	10/1945 Baker et al.	5,154,228	A	10/1992 Gambertoglio et al.
2,616,502	A	3/1948 Lenz	5,183,068	A	2/1993 Prosser
2,555,627	A	6/1951 Baker	5,188,182	A	2/1993 Echols, III et al.
2,589,506	A	3/1952 Morrisett	5,207,274	A	5/1993 Streich et al.
2,640,546	A	6/1953 Baker et al.	5,209,310	A	5/1993 Clydesdale
2,713,910	A	7/1955 Baker et al.	5,219,380	A	6/1993 Young et al.
2,714,932	A	8/1955 Thompson	5,224,540	A	7/1993 Streich et al.
2,737,242	A	3/1956 Baker	5,230,390	A	7/1993 Zastressek et al.
2,756,827	A	7/1956 Farrar	5,234,052	A	8/1993 Coone et al.
2,830,666	A	4/1958 Rhodes	5,253,705	A	10/1993 Clary et al.
2,833,354	A	5/1958 Sailors	5,295,735	A	3/1994 Cobbs et al.
3,013,612	A	12/1961 Angel	5,311,939	A	5/1994 Pringle et al.
3,054,453	A	9/1962 Bonner	5,316,081	A	5/1994 Baski et al.
3,062,296	A	11/1962 Brown	5,318,131	A	6/1994 Baker
3,082,824	A	3/1963 Taylor et al.	D350,887	S	9/1994 Sjolander et al.
3,094,166	A *	6/1963 McCullough ..... 166/63	5,343,954	A	9/1994 Bohlen et al.
3,160,209	A	12/1964 Bonner	D353,756	S	12/1994 Graves
3,163,225	A	12/1964 Perkins	D355,428	S	2/1995 Hatcher
3,273,588	A	9/1966 Dollison	5,390,737	A	2/1995 Jacobi et al.
3,282,342	A	11/1966 Mott	5,392,540	A	2/1995 Cooper et al.
3,291,218	A	12/1966 Lebourg	5,419,399	A	5/1995 Smith
3,298,437	A	1/1967 Conrad	RE35,088	E	11/1995 Gilbert
3,298,440	A	1/1967 Current	5,484,191	A	1/1996 Sollami
3,306,362	A	2/1967 Urbanosky	5,490,339	A	2/1996 Accettola
3,308,895	A	3/1967 Oxford et al.	5,540,279	A	7/1996 Branch et al.
3,356,140	A	12/1967 Young	5,564,502	A	10/1996 Crow et al.
3,393,743	A	7/1968 Stanescu	5,593,292	A	1/1997 Ivey et al.
3,429,375	A	2/1969 Craig	D377,969	S	2/1997 Grantham
3,517,742	A	6/1970 Williams	5,655,614	A	8/1997 Azar
3,554,280	A	1/1971 Tucker	5,701,959	A	12/1997 Hushbeck et al.
3,602,305	A	8/1971 Kisling	5,785,135	A	7/1998 Crawley
3,623,551	A	11/1971 Randermann, Jr.	5,791,825	A	8/1998 Gardner et al.
3,687,202	A	8/1972 Young et al.	5,803,173	A	9/1998 Fraser, III et al.
3,787,101	A	1/1974 Sugden	5,810,083	A	9/1998 Kilgore
3,818,987	A	6/1974 Ellis	5,819,846	A	10/1998 Bolt, Jr.
3,851,706	A	12/1974 Ellis	D415,180	S	10/1999 Rosanwo
3,860,066	A	1/1975 Pearce et al.	5,961,185	A	10/1999 Friant et al.
3,926,253	A	12/1975 Duke	5,984,007	A	11/1999 Yuan et al.
4,035,024	A	7/1977 Fink	5,988,277	A	11/1999 Vick, Jr. et al.
4,049,015	A	9/1977 Brown	6,012,519	A	1/2000 Allen et al.
4,134,455	A	1/1979 Read	6,082,451	A	7/2000 Giroux et al.
4,151,875	A	5/1979 Sullaway	6,085,446	A	7/2000 Posch
4,185,689	A	1/1980 Harris	6,098,716	A	8/2000 Hromas et al.
4,189,183	A	2/1980 Borowski	6,105,694	A	8/2000 Scott
4,250,960	A	2/1981 Chammas	6,142,226	A	11/2000 Vick
4,314,608	A	2/1982 Richardson	6,152,232	A	11/2000 Webb et al.
4,381,038	A	4/1983 Sugden	6,167,963	B1	1/2001 McMahan
4,391,547	A	7/1983 Jackson	6,182,752	B1	2/2001 Smith, Jr. et al.
4,405,017	A	9/1983 Allen et al.	6,199,636	B1	3/2001 Harrison
4,432,418	A	2/1984 Mayland	6,220,349	B1	4/2001 Vargus et al.
4,436,151	A	3/1984 Callihan et al.	6,283,148	B1	9/2001 Spears et al.
4,437,516	A	3/1984 Cockrell	6,341,823	B1	1/2002 Sollami
4,457,376	A	7/1984 Carmody et al.	6,367,569	B1	4/2002 Walk
4,493,374	A	1/1985 Magee, Jr.	6,394,180	B1	5/2002 Berscheidt et al.
4,532,995	A	8/1985 Kaufman	6,457,267	B1	10/2002 Porter et al.
4,548,442	A	10/1985 Sugden et al.	6,491,108	B1	12/2002 Slup
4,554,981	A	11/1985 Davies	6,543,963	B2	4/2003 Bruso
4,566,541	A	1/1986 Moussy et al.	6,578,638	B2 *	6/2003 Guillory et al. .... 166/387
4,585,067	A	4/1986 Blizzard et al.	6,581,681	B1	6/2003 Zimmerman et al.
4,595,052	A	6/1986 Kristiansen	6,604,763	B1	8/2003 Cook et al.
4,602,654	A	7/1986 Stehling et al.	6,629,563	B2	10/2003 Doane
4,688,641	A	8/1987 Knieriemmen	6,695,049	B2	2/2004 Ostocke et al.
4,708,163	A	11/1987 Deaton	6,708,768	B2	3/2004 Slup et al.
4,708,202	A	11/1987 Sukup et al.	6,708,770	B2	3/2004 Slup et al.
D293,798	S	1/1988 Johnson	6,725,935	B2	4/2004 Szarka et al.
4,776,410	A	10/1988 Perkin et al.	6,739,398	B1	5/2004 Yokley et al.
4,784,226	A	11/1988 Wyatt	6,769,491	B2	8/2004 Zimmerman et al.
4,792,000	A	12/1988 Perkin et al.	6,779,948	B2	8/2004 Bruso
4,830,103	A	5/1989 Blackwell et al.	6,796,376	B2	9/2004 Frazier
4,848,459	A	7/1989 Blackwell et al.	6,799,633	B2	10/2004 McGregor
4,893,678	A	1/1990 Stokley et al.	6,834,717	B2	12/2004 Bland
4,898,245	A	2/1990 Braddick	6,851,489	B2	2/2005 Hinds
5,020,590	A	6/1991 McLeod	6,854,201	B1	2/2005 Hunter et al.
5,074,063	A	12/1991 Vannette	6,902,006	B2	6/2005 Myerley et al.
5,082,061	A	1/1992 Dollison	6,918,439	B2	7/2005 Dallas
5,095,980	A	3/1992 Watson	6,938,696	B2	9/2005 Dallas
			6,944,977	B2	9/2005 Deniau et al.

7,055,632 B2 6/2006 Dallas  
 7,069,997 B2 7/2006 Coyes et al.  
 7,107,875 B2 9/2006 Haugen et al.  
 7,124,831 B2 10/2006 Turley et al.  
 7,128,091 B2 10/2006 Istre, Jr.  
 7,150,131 B2 12/2006 Barker  
 7,168,494 B2 1/2007 Starr et al.  
 7,281,584 B2 10/2007 McGarian et al.  
 D560,109 S 1/2008 Huang  
 7,325,617 B2 2/2008 Murray  
 7,337,847 B2 3/2008 McGarian et al.  
 7,350,582 B2 4/2008 McKeachnie et al.  
 7,353,879 B2 4/2008 Todd et al.  
 7,363,967 B2 4/2008 Burris, II et al.  
 7,373,973 B2 5/2008 Smith et al.  
 7,428,922 B2 9/2008 Fripp et al.  
 7,527,104 B2 5/2009 Branch et al.  
 7,552,779 B2 6/2009 Murray  
 D597,110 S 7/2009 Anitua Aldecoa  
 7,600,572 B2\* 10/2009 Slup et al. .... 166/386  
 7,604,058 B2 10/2009 McGuire  
 7,637,326 B2 12/2009 Bolding et al.  
 7,644,767 B2 1/2010 Kalb et al.  
 7,644,774 B2 1/2010 Branch et al.  
 D612,875 S 3/2010 Beynon  
 7,673,677 B2 3/2010 King et al.  
 7,690,436 B2 4/2010 Turley et al.  
 D618,715 S 6/2010 Corcoran  
 7,735,549 B1 6/2010 Nish et al.  
 7,740,079 B2 6/2010 Clayton et al.  
 7,775,286 B2 8/2010 Duphorne  
 7,775,291 B2 8/2010 Jacob  
 7,784,550 B2 8/2010 Nutley et al.  
 7,798,236 B2 9/2010 McKeachnie et al.  
 7,810,558 B2 10/2010 Shkurti et al.  
 D629,820 S 12/2010 Van Ryswyk  
 7,866,396 B2 1/2011 Rytlewski  
 7,878,242 B2 2/2011 Gray  
 7,886,830 B2 2/2011 Bolding et al.  
 7,900,696 B1 3/2011 Nish et al.  
 7,909,108 B2 3/2011 Swor et al.  
 7,909,109 B2 3/2011 Angman et al.  
 D635,429 S 4/2011 Hakki  
 7,918,278 B2 4/2011 Barbee  
 7,921,923 B2 4/2011 McGuire  
 7,921,925 B2 4/2011 Maguire et al.  
 7,926,571 B2 4/2011 Hofman  
 8,074,718 B2 12/2011 Roberts  
 8,079,413 B2 12/2011 Frazier  
 8,104,539 B2 1/2012 Stanojic et al.  
 8,113,276 B2 2/2012 Greenlee et al.  
 8,127,856 B1 3/2012 Nish et al.  
 D657,807 S 4/2012 Frazier

2003/0024706 A1 2/2003 Allamon  
 2003/0188860 A1 10/2003 Zimmerman et al.  
 2007/0051521 A1 3/2007 Fike et al.  
 2007/0107908 A1 5/2007 Vaidya et al.  
 2007/0151722 A1 7/2007 Lehr et al.  
 2008/0110635 A1 5/2008 Loretz et al.  
 2009/0114401 A1 5/2009 Purkis  
 2009/0211749 A1 8/2009 Nguyen et al.  
 2010/0132960 A1 6/2010 Shkurti et al.  
 2010/0155050 A1 6/2010 Frazier  
 2010/0252252 A1 10/2010 Harris et al.  
 2010/0263876 A1 10/2010 Frazier  
 2010/0276159 A1 11/2010 Mailand et al.  
 2010/0288503 A1 11/2010 Cuiper et al.  
 2011/0036564 A1 2/2011 Williamson  
 2011/0061856 A1 3/2011 Kellner et al.  
 2011/0103915 A1 5/2011 Tedeschi

OTHER PUBLICATIONS

“78/79 Catalog: Packers-Plugs-Completions Tools,” Pengo Industries, Inc., 1978-1979 (12 pages).  
 “MAP Oil Tools Inc. Catalog,” MAP Oil Tools, Apr. 1999 (46 pages).  
 “Lovejoy-where the world turns for couplings,” Lovejoy, Inc., Dec. 2000 (30 pages).  
 “Halliburton Services, Sales & Service Catalog,” Halliburton Services, 1970-1971 (2 pages).  
 “1975-1976 Packer Catalog,” Gearhart-Owen Industries Inc., 1975-1976 (52 Pages).  
 “Formation Damage Control Utilizing Composite-Bridge Plug Technology for Monobore, Multizone Stimulation Operations,” Gary Garfield, SPE, May 15, 2001 (8 pages).  
 “Composite Bridge Plug Technique for Multizone Commingled Gas Wells,” Gary Garfield, SPE, Mar. 24, 2001 (6 pages).  
 “Composite Research: Composite bridge plugs used in multi-zone wells to avoid costly kill-weight fluids,” Gary Garfield, SPE, Mar. 24, 2001 (4 pages).  
 “It’s About Time-Quick Drill Composite Bridge Plug,” Baker Oil Tools, Jun. 2002 (2 pages).  
 “Baker Hughes-Baker Oil Tools-Workover Systems-QUIK Drill Composite Bridge Plug,” Baker Oil Tools, Dec. 2000 (3 pages).  
 “Baker Hughes 100 Years of Service,” Baker Hughes in Depth, Special Centennial Issue, Publication Cor-07-13127, vol. 13, No. 2, Baker Hughes Incorporated, Jul. 2007 (92 pages).  
 “Halliburton Services, Sales & Service Catalog No. 43,” Halliburton Co. 1985 (202 pages).  
 “Alpha Oil Tools Catalog,” Alpha Oil Tools, 1997 (136 pages).  
 Petition for Inter Partes Review for U.S. Patent No. 8,079,413 (U.S. Appl. No. 13/194,871); Case No. 2013-00231; Filed Apr. 2, 2013; Administrative Patent Judge Sally C. Medley.

\* cited by examiner

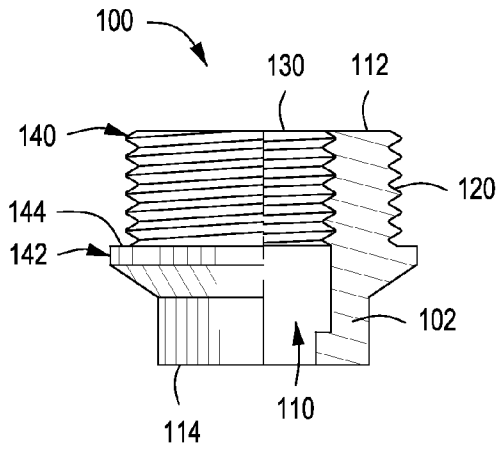

FIG. 1A

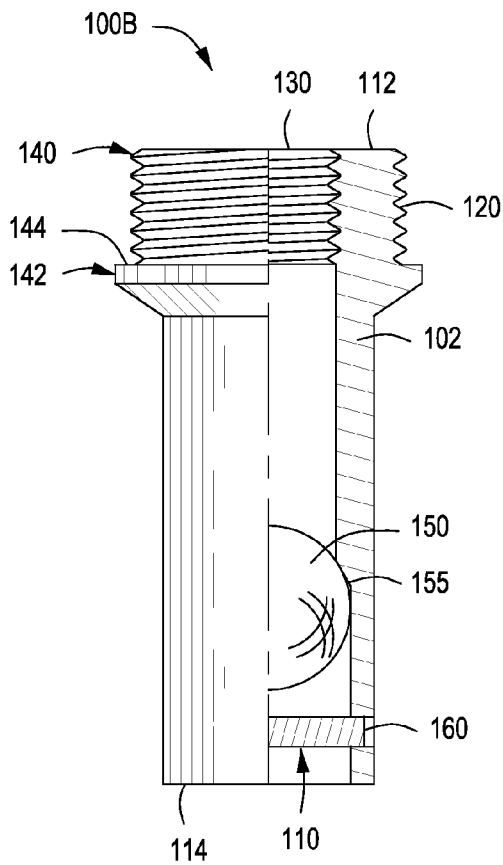

FIG. 1B

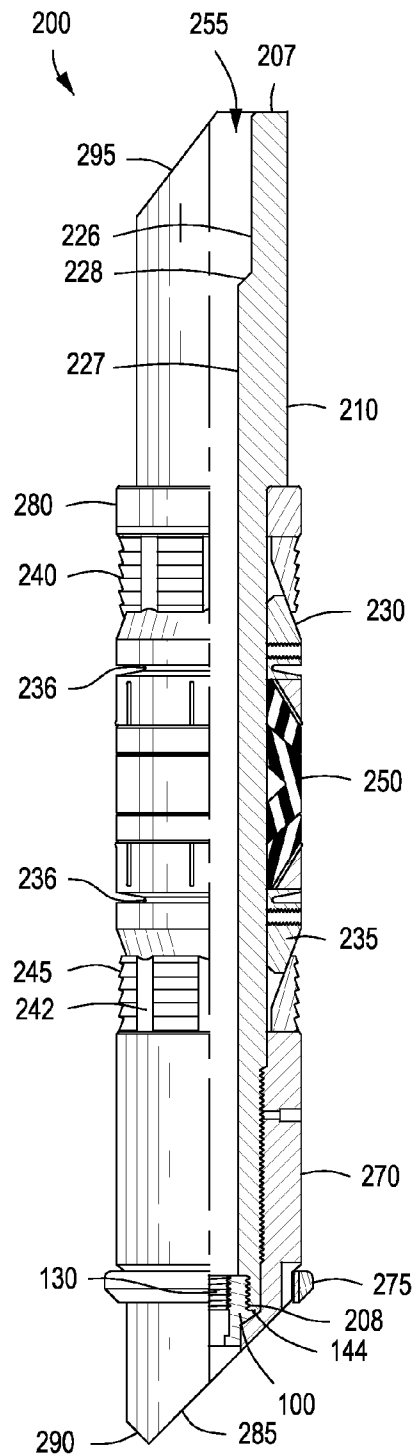

FIG. 2A

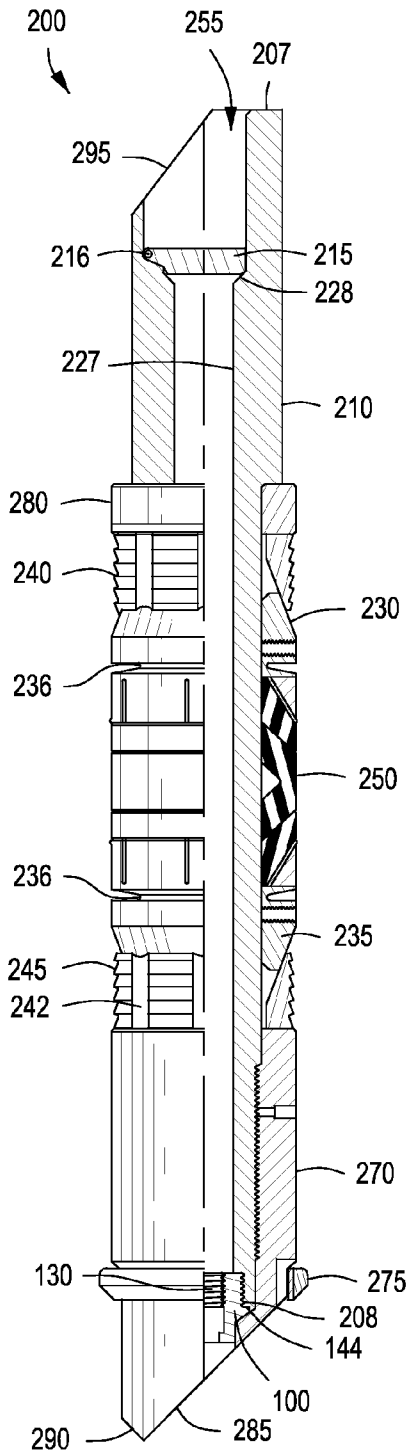

FIG. 2B

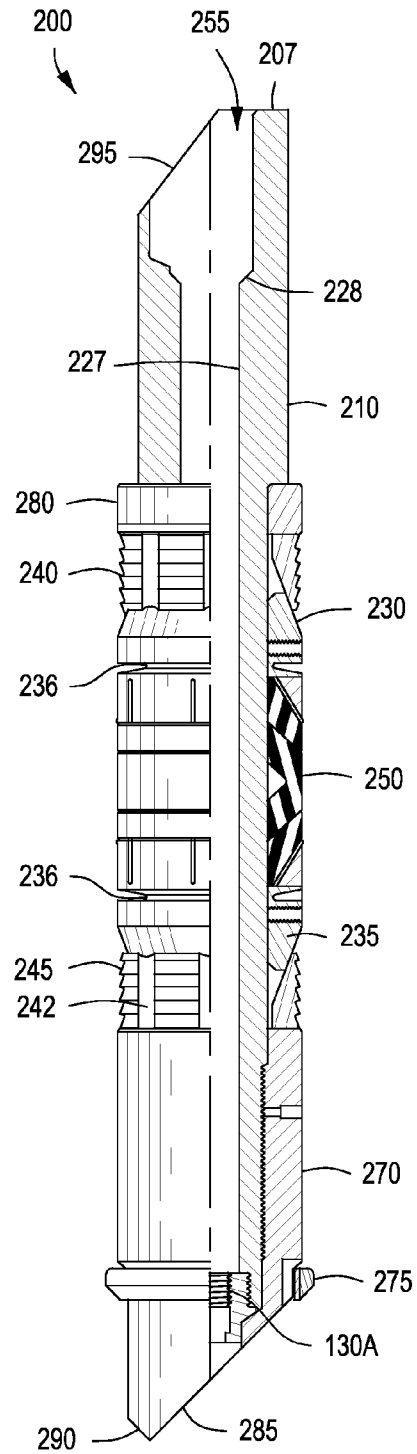

FIG. 2C

# Explore Litigation Insights

Docket Alarm provides insights to develop a more informed litigation strategy and the peace of mind of knowing you're on top of things.

## Real-Time Litigation Alerts



Keep your litigation team up-to-date with **real-time alerts** and advanced team management tools built for the enterprise, all while greatly reducing PACER spend.

Our comprehensive service means we can handle Federal, State, and Administrative courts across the country.

## Advanced Docket Research



With over 230 million records, Docket Alarm's cloud-native docket research platform finds what other services can't. Coverage includes Federal, State, plus PTAB, TTAB, ITC and NLRB decisions, all in one place.

Identify arguments that have been successful in the past with full text, pinpoint searching. Link to case law cited within any court document via Fastcase.

## Analytics At Your Fingertips



Learn what happened the last time a particular judge, opposing counsel or company faced cases similar to yours.

Advanced out-of-the-box PTAB and TTAB analytics are always at your fingertips.

## API

Docket Alarm offers a powerful API (application programming interface) to developers that want to integrate case filings into their apps.

## LAW FIRMS

Build custom dashboards for your attorneys and clients with live data direct from the court.

Automate many repetitive legal tasks like conflict checks, document management, and marketing.

## FINANCIAL INSTITUTIONS

Litigation and bankruptcy checks for companies and debtors.

## E-DISCOVERY AND LEGAL VENDORS

Sync your system to PACER to automate legal marketing.