



US005550646A

# United States Patent [19]

[11] Patent Number: **5,550,646**

Hassan et al.

[45] Date of Patent: **Aug. 27, 1996**

- [54] **IMAGE COMMUNICATION SYSTEM AND METHOD**
- [75] Inventors: **Ahmad M. Hassan**, Madison; **Russel R. Johnston**, Bedminster; **John C. Krejci**, Sparta, all of N.J.
- [73] Assignee: **Lucent Technologies Inc.**, Murray Hill, N.J.
- [21] Appl. No.: **120,254**
- [22] Filed: **Sep. 13, 1993**
- [51] Int. Cl.<sup>6</sup> ..... **H04N 1/32**
- [52] U.S. Cl. .... **358/442; 358/400; 379/100; 348/18**
- [58] Field of Search ..... **358/400, 440, 358/468, 442, 909.1, 456, 457; 379/96-98, 100; 348/14, 17, 18; 370/94.1, 94.2, 95.1; H04N 1/00, 1/32**

A. Mathur et al. "Image Management Software for Decompressions, Scaling and Display of Digitized Images", Electronic Imaging 88—International Electronic Imaging Exposition & Conference, Oct. 1988. pp. 1208-1213.

M. Rabbani et al. "An Optimized Image Data Compression Technique Utilized in the Kodak SV9600 Still Video Transceiver", Proceedings of the SPIE—The International Society for Optical Engineering, vol. 1071, 1989, pp. 246-256.

L. P. Glidewell "Filmless Camera Technology Boosts Image Transmission", Defense Electronics, Jun. 1989, pp. 105-112.

Primary Examiner—Kim Yen Vu  
Attorney, Agent, or Firm—Barry H. Freedman; Mark K. Young

### [56] References Cited

#### U.S. PATENT DOCUMENTS

|           |         |                   |         |
|-----------|---------|-------------------|---------|
| 3,953,668 | 4/1976  | Judice            | 348/910 |
| 4,587,633 | 5/1986  | Wang et al.       | 379/96  |
| 4,614,977 | 9/1986  | Kawasaki et al.   | 358/260 |
| 4,646,160 | 2/1987  | Iizuka et al.     | 358/402 |
| 4,811,239 | 3/1989  | Tsao et al.       | 364/519 |
| 4,827,085 | 5/1989  | Yaniv et al.      | 178/18  |
| 5,020,096 | 5/1991  | Sakakibara et al. | 379/96  |
| 5,036,390 | 7/1991  | Masunaga          | 348/14  |
| 5,086,455 | 2/1992  | Satomi et al.     | 379/100 |
| 5,136,628 | 8/1992  | Araki et al.      | 348/18  |
| 5,182,635 | 1/1993  | Nakashima et al.  | 348/17  |
| 5,237,429 | 8/1993  | Zuiss et al.      | 379/100 |
| 5,263,025 | 11/1993 | Torri et al.      |         |

#### OTHER PUBLICATIONS

Table of Contents—Electronic Imaging 88—International Electronic Imaging Exposition & Conference, Oct. 1988.  
H. Farhangi et al. "A Microprocessor-Based Still Frame Capturing System" Displays, Oct. 1982, pp. 212-217.

### [57] ABSTRACT

An image communication system and method includes an image capture device which utilizes CCD technology to "take a picture", i.e., to capture an image, and then to generate a digital representation of that image which may be applied to a fax modem and then transmitted to a remote facsimile machine via a telephone communication link. The digital image is processed, such as by dithering, to enhance its presentability, so that shades of gray present in a conventional black and white photograph are converted to a pattern of black and white dots which retains the character of the original image in spite of subsequent facsimile transmission. The image capture device may include a printer and a memory for storing multiple images as well as the destination numbers of facsimile machines which are intended to receive copies of the images.

7 Claims, 4 Drawing Sheets

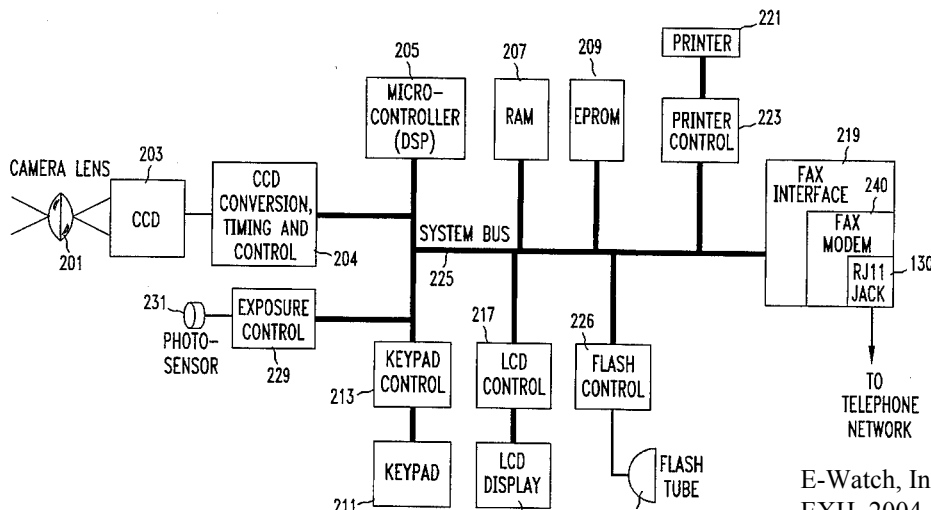

E-Watch, Inc.  
EXH. 2004

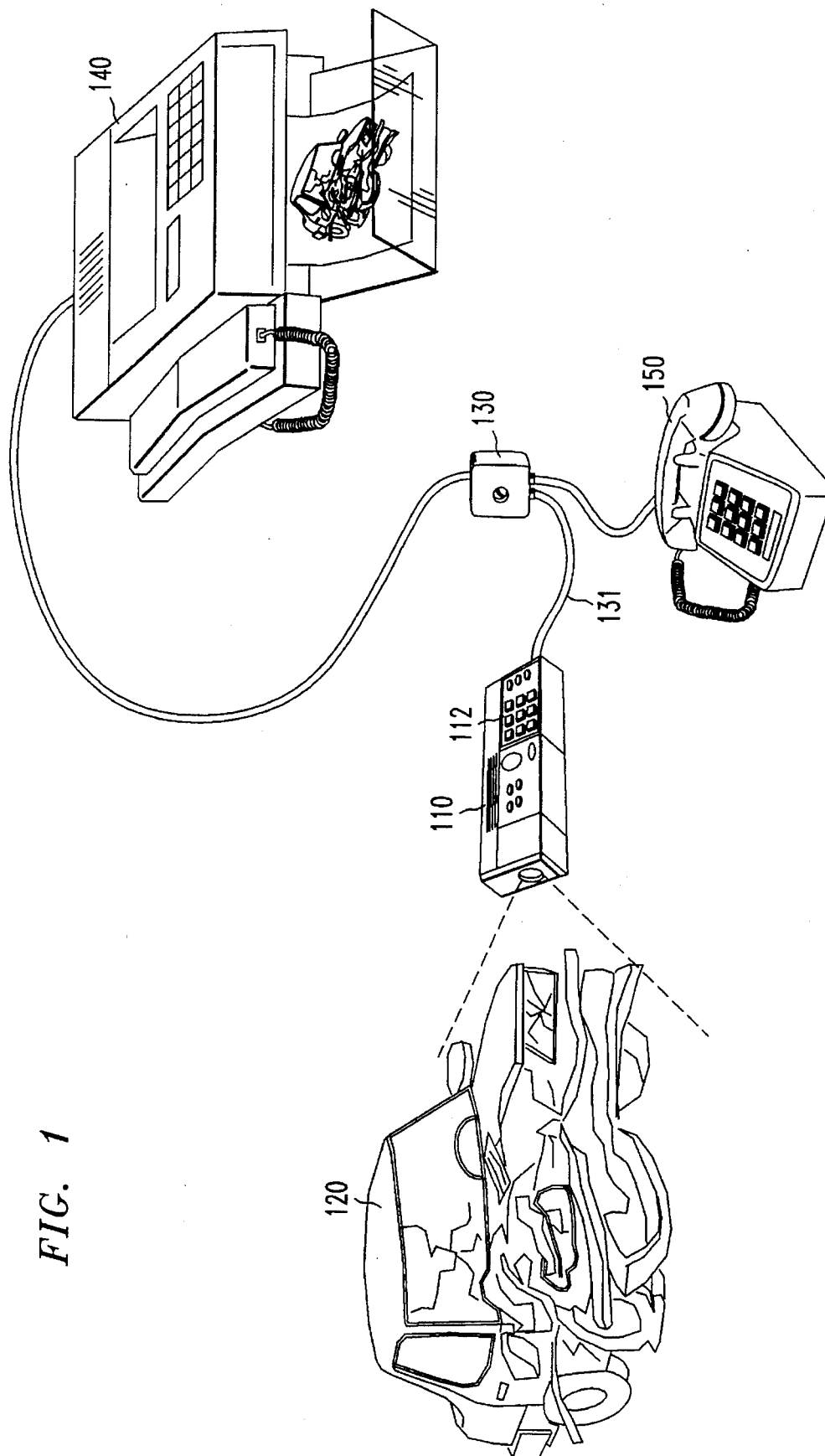

FIG. 1

FIG. 2

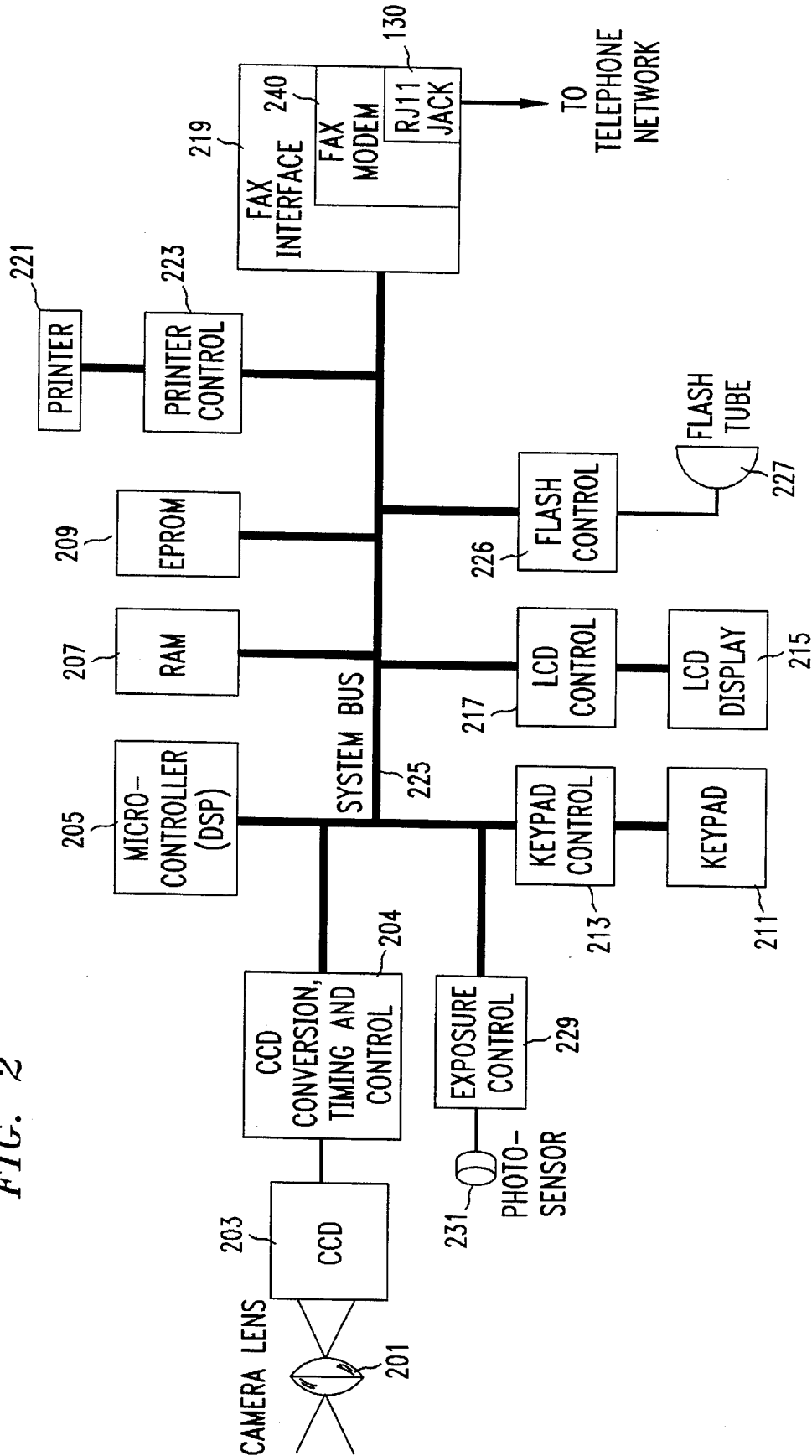
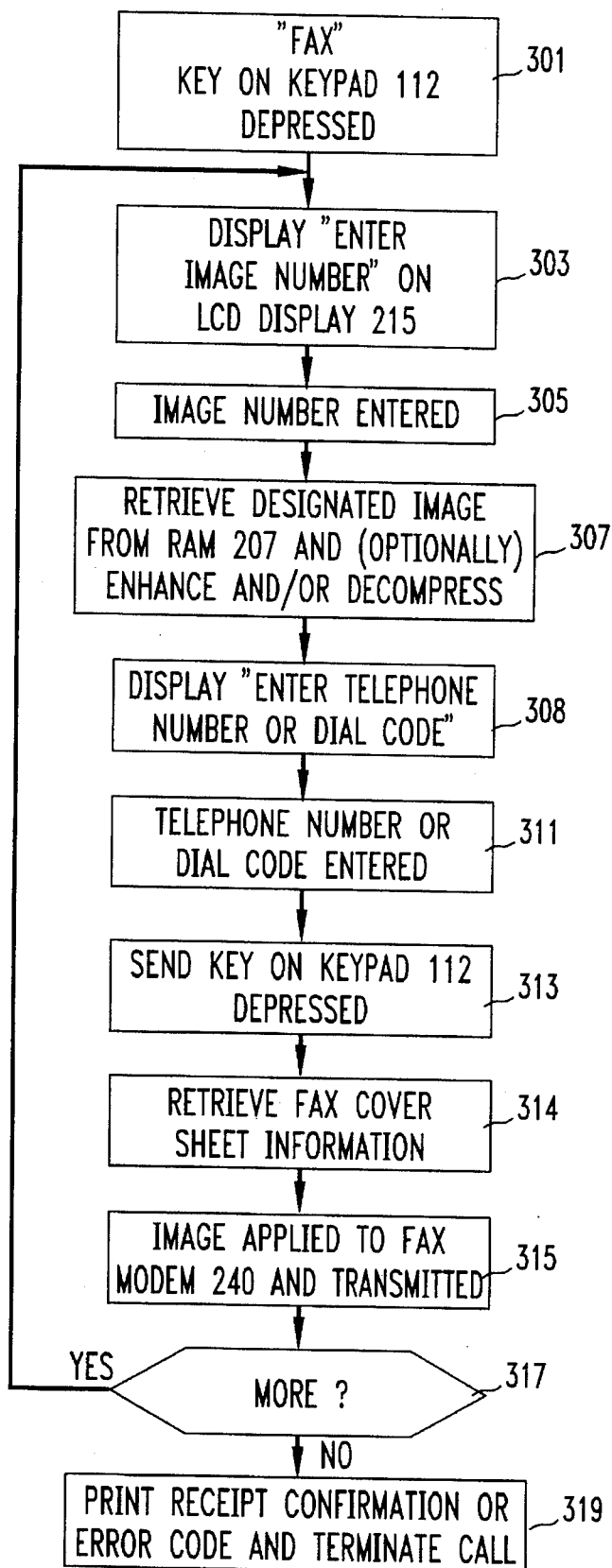
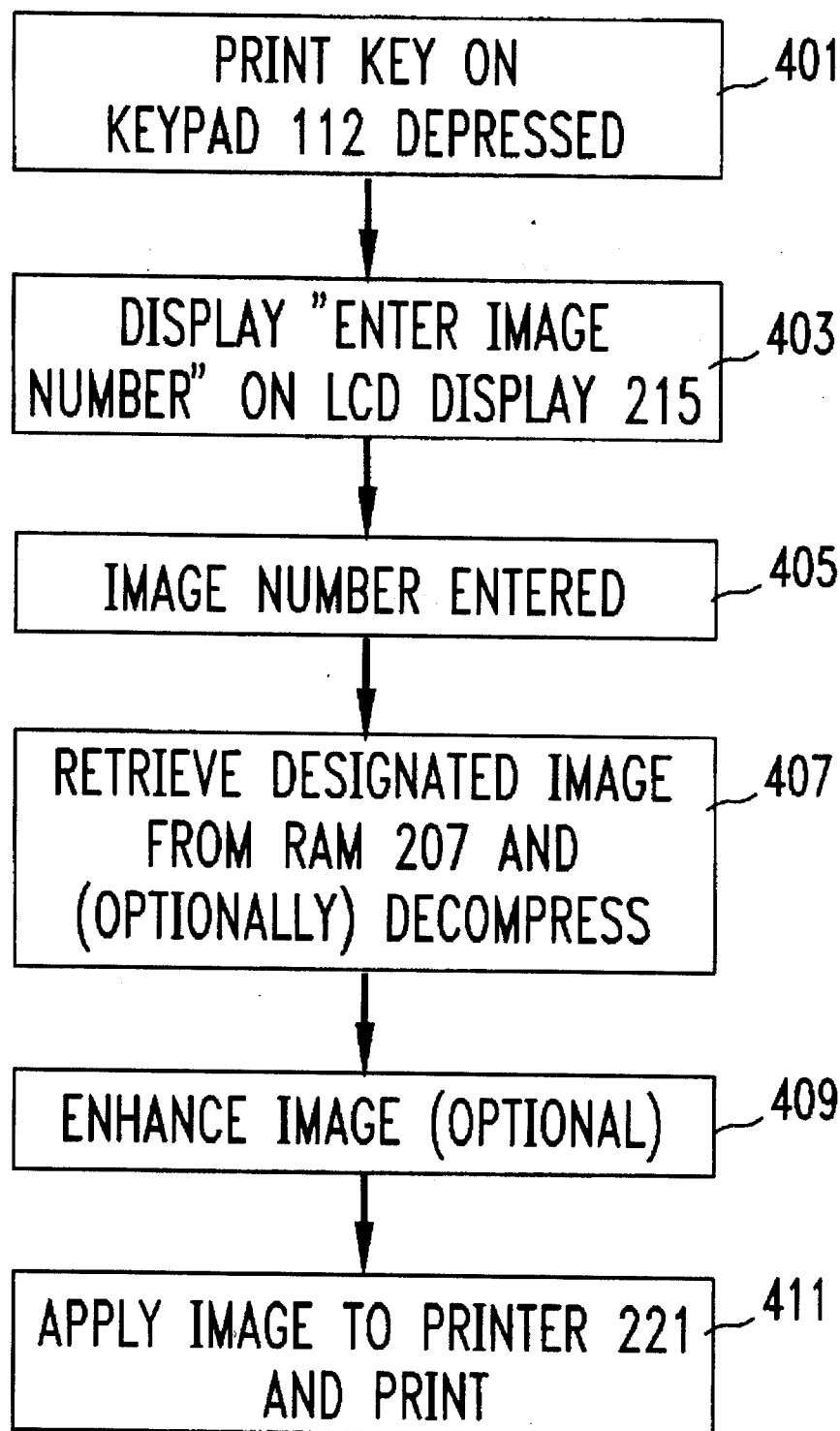

FIG. 3



*FIG. 4*

# Explore Litigation Insights

Docket Alarm provides insights to develop a more informed litigation strategy and the peace of mind of knowing you're on top of things.

## Real-Time Litigation Alerts



Keep your litigation team up-to-date with **real-time alerts** and advanced team management tools built for the enterprise, all while greatly reducing PACER spend.

Our comprehensive service means we can handle Federal, State, and Administrative courts across the country.

## Advanced Docket Research



With over 230 million records, Docket Alarm's cloud-native docket research platform finds what other services can't. Coverage includes Federal, State, plus PTAB, TTAB, ITC and NLRB decisions, all in one place.

Identify arguments that have been successful in the past with full text, pinpoint searching. Link to case law cited within any court document via Fastcase.

## Analytics At Your Fingertips



Learn what happened the last time a particular judge, opposing counsel or company faced cases similar to yours.

Advanced out-of-the-box PTAB and TTAB analytics are always at your fingertips.

## API

Docket Alarm offers a powerful API (application programming interface) to developers that want to integrate case filings into their apps.

## LAW FIRMS

Build custom dashboards for your attorneys and clients with live data direct from the court.

Automate many repetitive legal tasks like conflict checks, document management, and marketing.

## FINANCIAL INSTITUTIONS

Litigation and bankruptcy checks for companies and debtors.

## E-DISCOVERY AND LEGAL VENDORS

Sync your system to PACER to automate legal marketing.