

UNITED STATES PATENT AND TRADEMARK OFFICE

---

BEFORE THE PATENT TRIAL AND APPEAL BOARD

---

INTERNATIONAL BUSINESS MACHINES CORPORATION  
AND  
ORACLE AMERICA, INC.,  
Petitioners,

v.

ELECTRONICS AND TELECOMMUNICATIONS RESEARCH  
INSTITUTE,  
Patent Owner.

---

Case IPR2014-00949  
Patent 6,978,346 B2

Before BRIAN J. McNAMARA, MIRIAM L. QUINN, and  
GREGG I. ANDERSON, *Administrative Patent Judges*.

ANDERSON, *Administrative Patent Judge*.

DECISION  
Institution of *Inter Partes* Review  
37 C.F.R. § 42.108

## I. INTRODUCTION

On July 21, 2014, International Business Machines, Corporation and Oracle America, Inc. (“Petitioners”) filed a Second Corrected Petition requesting an *inter partes* review of claims 1–9 of U.S. Patent No. 6,978,346 B2 (Ex. 1001, “the ’346 patent”). Paper 6 (“Pet.”). Electronics and Telecommunications Research Institute (“Patent Owner”) filed a Preliminary Response. Paper 16 (“Prelim. Resp.”). Applying the standard set forth in 35 U.S.C. § 314(a), which requires demonstration of a reasonable likelihood that Petitioners would prevail with respect to at least one challenged claim, we institute an *inter partes* review of claims 1–9. The Board has not made a final determination of the patentability of any claim.

### A. Related Proceedings

Petitioners advise that the ’346 patent is involved in the following co-pending district court cases: *Safe Storage LLC v. StoneFly, Inc.*, 1-13-cv-01152; *Safe Storage LLC v. Int’l Bus. Machs. Corp.*, 1-13-cv-01151; *Safe Storage LLC v. Emulex Corp. et al.*, 1-13-cv-01150; *Safe Storage LLC v. 3PAR Inc.*, 1-13-cv-01088; *Safe Storage LLC v. Oracle Am. Inc. et al.*, 1-13-cv-01089; *Safe Storage LLC v. ATTO Tech. Inc. et al.*, 1-13-cv-01090; *Safe Storage LLC v. VMware Inc.*, 1-13-cv-00928; *Safe Storage LLC v. Promise Tech. Inc.*, 1-13-cv-00927; *Safe Storage LLC v. Nexsan Corp.*, 1-13-cv-00931; *Safe Storage LLC v. Overland Storage Inc.*, 1-13-cv-00932; *Safe Storage LLC v. IQSS LLC*, 1-13-cv-00930; *Safe Storage LLC v. Infortrend Corp.*, 1-13-cv-00929; *Safe Storage LLC v. Cisco Sys. Inc.*, 1-13-cv-00926; *Safe Storage LLC v. Silicon Graphics Int’l Corp.*, 1-12-cv-01629; *Safe Storage LLC v. Dot Hill Sys. Corp.*, 1-12-cv-01625; *Safe Storage LLC v. Hitachi Data Sys. Corp.*, 1-12-cv-01627; *Safe Storage LLC v. Dell Inc.*, 1-

IPR2014-00949  
Patent 6,978,346 B2

12-cv-01624; *Safe Storage LLC v. NetApp Inc.*, 1-12-cv-01628; and *Safe Storage LLC v. Hewlett-Packard Co.*, 1-12-cv-01626, all pending in the United States District Court for the District of Delaware.<sup>1</sup> Pet. 1; Paper 5, 2–3. The '346 patent is the subject of an instituted *inter partes* review in *Dell Inc. v. Electronics and Telecommunications Research Institute*, Case IPR2013-00635 (PTAB) (“the '635 IPR”). *Id.* Additional petitions for review have been filed in *VMware, Inc. v. Electronics and Telecommunications Research Institute*, Case IPR2014-00901 (PTAB) and *International Business Machines Corp. v. Electronics and Telecommunications Research Institute*, Case IPR2014-00976 (PTAB). *Id.*

#### B. '346 Patent

The '346 patent describes an apparatus with “redundant interconnection between multiple hosts and a redundant array of inexpensive disks (hereinafter referred to as ‘RAID’).” Ex. 1001, Abstract. As a result of the redundant interconnection, the apparatus allows increased bandwidth in the event one of the two RAID controllers 460 and 461 has a failure. *Id.* at 3:1–9.

---

<sup>1</sup> Petitioners list only the case numbers. The case names are provided from IPR2013-00635, which Petitioners identify here.

Figure 4 of the '346 patent is reproduced below:

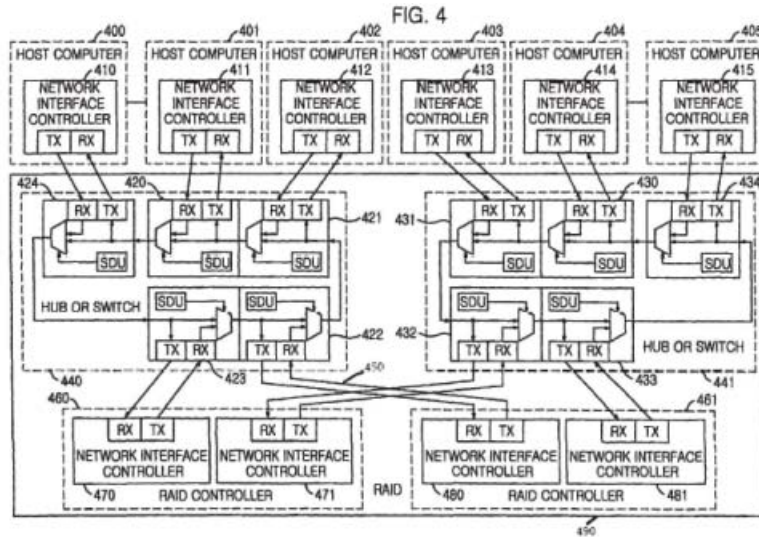

Figure 4 is a block diagram of a host matching system including RAID 490 and its interconnection to host computers 400-405. Ex. 1001, 2:64–3:6. RAID 490 includes two RAID controllers 460, 461 and hubs 440, 441. *Id.* at 3:10–18. Each RAID controller includes a pair of network interface controllers. For example, RAID controller 460 includes network interface controllers 470, 471, and RAID controller 461 includes network interface controllers 480, 481. *Id.* at 3:11–13. Each host computer has its own network interface controller (410 to 415), which connects the host computer through the hubs and to network interface controllers (470, 471, 480, 481) of RAID controllers 460, 461. *Id.* at 3:31–35.

The '346 patent describes that the result is two independent networks with twice the bandwidth of a single network and a “communication passage” between the two RAID controllers. *Id.* at 3:62–64. The communication passage creates a “fault tolerant function” should one of RAID controllers 460 or 461 fail. *Id.* at 3:64–66. According to Figure 4, communications line 450 interconnects network interface controller 480 of

RAID controller 461 and network interface controller 470 of RAID controller 460. *Id.* at 4:2–6; Fig. 4. Then, RAID controller 461 may send information to RAID controller 460. *Id.* In like manner, network interface controller 471 of RAID controller 460 may be connected over communications lines to network interface controller 481 of RAID controller 461, allowing RAID controller 460 to send information to RAID controller 461. *Id.* at 3:66–4:2.

By the arrangement described, the apparatus continues to operate in the event either RAID controller 460 or 461 has an “occurrence of an error.” Ex. 1001, 4:19–25. The interconnected network interface controller of the operational RAID controller assumes the functions of the network interface controller of the failed RAID controller. *Id.*

### *C. Illustrative Claim*

Claim 1, one of the two independent claims of the challenged claims, is reproduced below:

1. An apparatus for a redundant interconnection between multiple hosts and a RAID, comprising:

a first RAID controlling units and a second RAID controlling unit for processing a requirement of numerous host computers, the first RAID controlling unit including a first network controlling unit and a second network controlling unit, and the second RAID controlling unit including a third network controlling unit and a fourth network controlling unit; and

a plurality of connection units for connecting the first RAID controlling units and the second RAID controlling unit to the numerous host computers, wherein the first RAID controlling unit and the second RAID controlling unit directly exchange information with the numerous host computers through the plurality of connecting units, and the first network controlling unit exchanges information with the fourth network controlling

# Explore Litigation Insights

Docket Alarm provides insights to develop a more informed litigation strategy and the peace of mind of knowing you're on top of things.

## Real-Time Litigation Alerts



Keep your litigation team up-to-date with **real-time alerts** and advanced team management tools built for the enterprise, all while greatly reducing PACER spend.

Our comprehensive service means we can handle Federal, State, and Administrative courts across the country.

## Advanced Docket Research



With over 230 million records, Docket Alarm's cloud-native docket research platform finds what other services can't. Coverage includes Federal, State, plus PTAB, TTAB, ITC and NLRB decisions, all in one place.

Identify arguments that have been successful in the past with full text, pinpoint searching. Link to case law cited within any court document via Fastcase.

## Analytics At Your Fingertips



Learn what happened the last time a particular judge, opposing counsel or company faced cases similar to yours.

Advanced out-of-the-box PTAB and TTAB analytics are always at your fingertips.

## API

Docket Alarm offers a powerful API (application programming interface) to developers that want to integrate case filings into their apps.

## LAW FIRMS

Build custom dashboards for your attorneys and clients with live data direct from the court.

Automate many repetitive legal tasks like conflict checks, document management, and marketing.

## FINANCIAL INSTITUTIONS

Litigation and bankruptcy checks for companies and debtors.

## E-DISCOVERY AND LEGAL VENDORS

Sync your system to PACER to automate legal marketing.