



US005841201A

United States Patent [19]

[11] Patent Number: **5,841,201**

Tabata et al.

[45] Date of Patent: **Nov. 24, 1998**

[54] **HYBRID VEHICLE DRIVE SYSTEM HAVING A DRIVE MODE USING BOTH ENGINE AND ELECTRIC MOTOR**

[75] Inventors: **Atsushi Tabata, Okazaki; Yutaka Taga, Aichi-ken; Ryuji Ibaraki, Toyota; Tsuyoshi Mikami, Toyota; Hiroshi Hata, Toyota, all of Japan**

[73] Assignee: **Toyota Jidosha Kabushiki Kaisha, Toyota, Japan**

[21] Appl. No.: **805,164**

[22] Filed: **Feb. 24, 1997**

[30] Foreign Application Priority Data

Feb. 29, 1996	[JP]	Japan	8-042943
May 27, 1996	[JP]	Japan	8-132105

[51] Int. Cl.⁶ **H02P 9/04**

[52] U.S. Cl. **290/40 C; 180/65.4; 290/16; 290/27; 318/143; 322/16**

[58] Field of Search **290/11, 16, 27, 290/40 C; 180/65.1, 65.4; 318/139, 143; 322/14, 15, 16**

[56] References Cited

U.S. PATENT DOCUMENTS

5,176,213	1/1993	Kawai et al.	180/243
5,343,970	9/1994	Severinsky	180/65.2
5,545,928	8/1996	Kotani	290/40 C
5,550,445	8/1996	Nii	318/153
5,588,498	12/1996	Kitada	180/65.4

5,621,304	4/1997	Kiuchi et al.	322/18
5,650,931	7/1997	Nii	364/424.026
5,656,921	8/1997	Farrall	322/40
5,698,955	12/1997	Nii	318/139
5,722,911	3/1998	Ibaraki et al.	477/3
5,751,137	5/1998	Kiuchi et al.	322/14

FOREIGN PATENT DOCUMENTS

A-3-121928	5/1991	Japan
A-6-80048	3/1994	Japan

Primary Examiner—Steven L. Stephan
Assistant Examiner—Nicholas Ponomarenko
Attorney, Agent, or Firm—Oliff & Berridge, PLC

[57] ABSTRACT

A hybrid drive system for a motor vehicle, having a power drive state in which there is available a power drive mode in which an engine and an electric motor are both operated as a drive power source for driving the vehicle, and wherein a manually operated power drive selector is provided for selecting the power drive mode, and a power drive restricting device is provided to inhibit the vehicle from being driven in the power drive state and therefore in the power drive mode if the power drive selector is not manually operated. The hybrid drive system may have an engine assist drive mode in which the electric motor is operated as an auxiliary drive power source, together with the engine operated as a primary drive power source, according to a selected one of different drivability modes of the vehicle selected by a manually operated drivability performance selector.

12 Claims, 21 Drawing Sheets

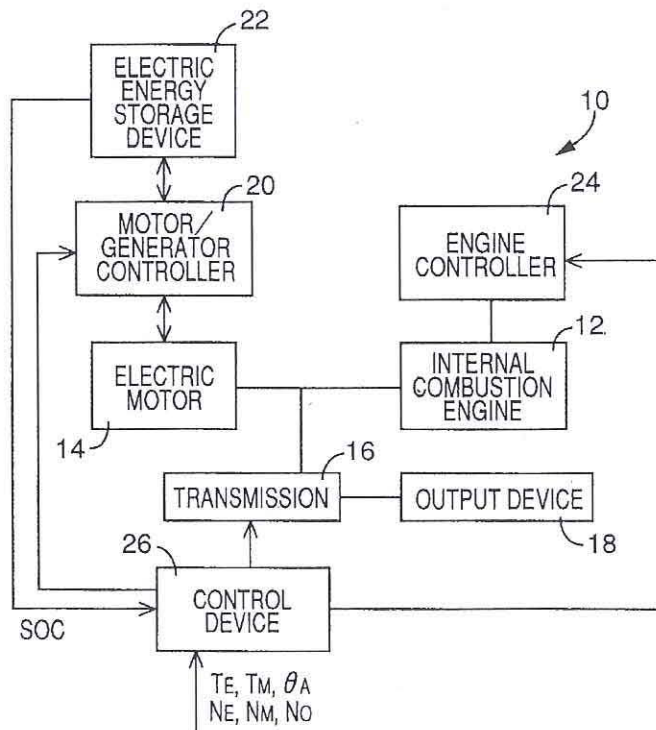

EXHIBIT 9
 WIT: N. Hanne mann
 DATE: 4-30-2015

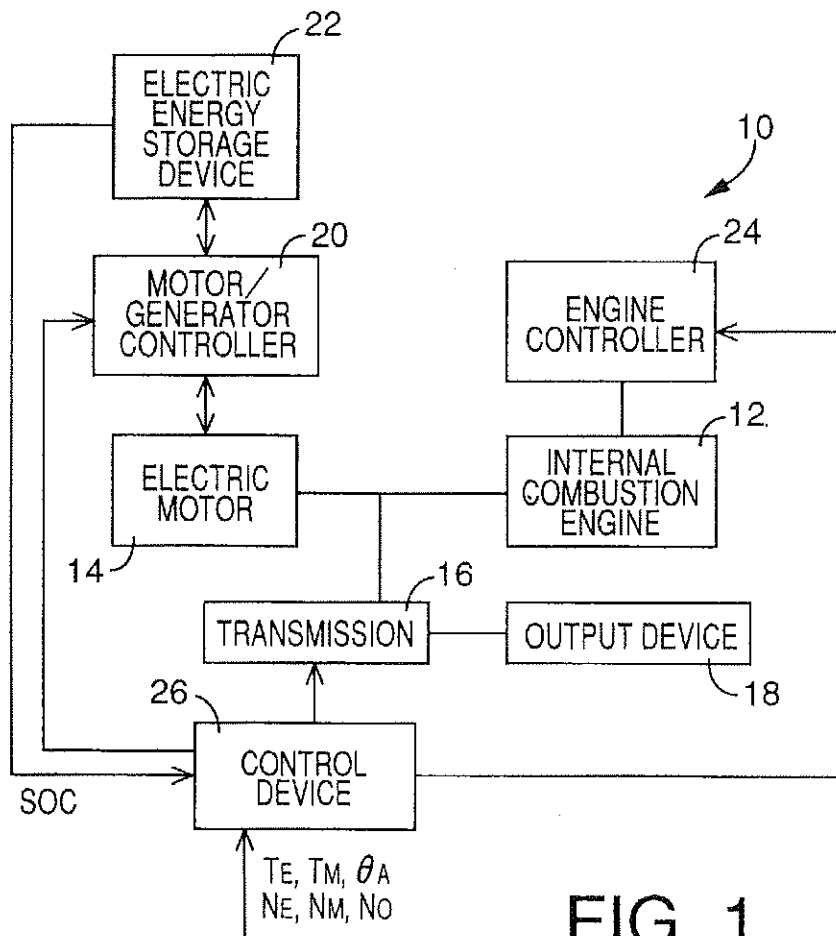

FIG. 1

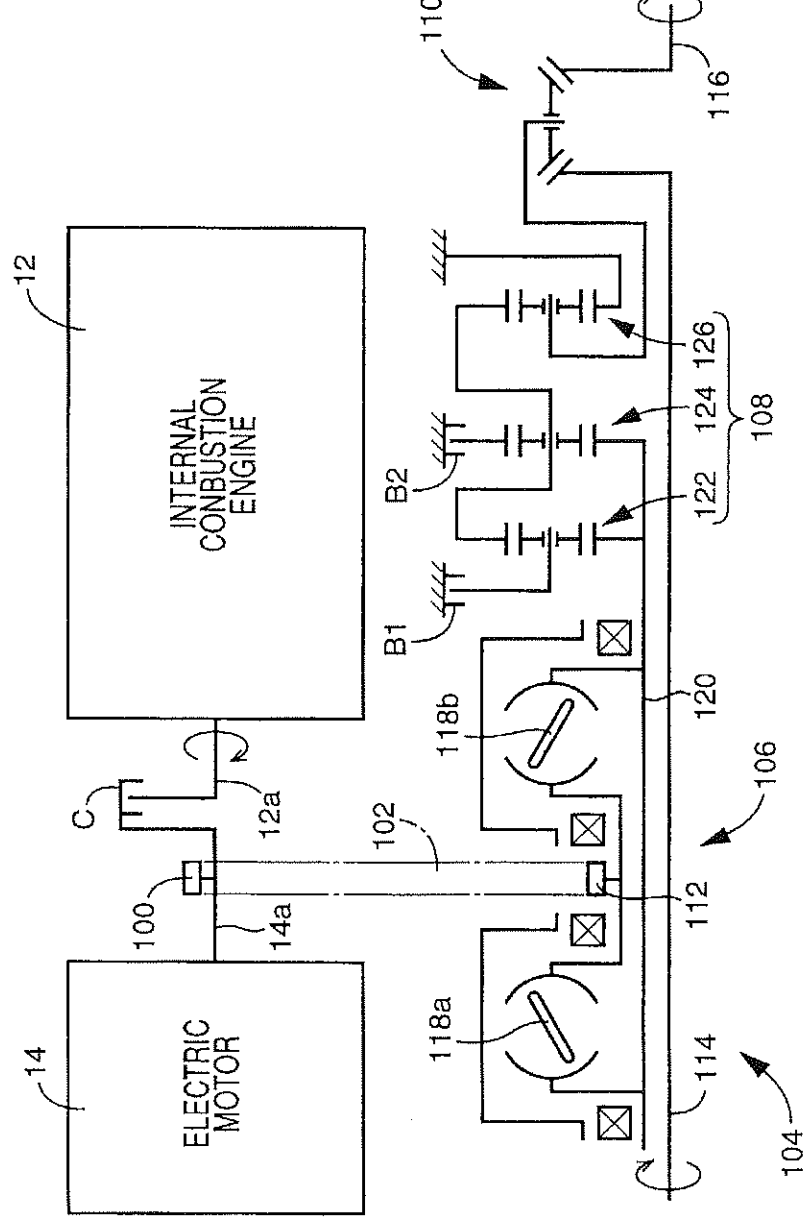

FIG. 2

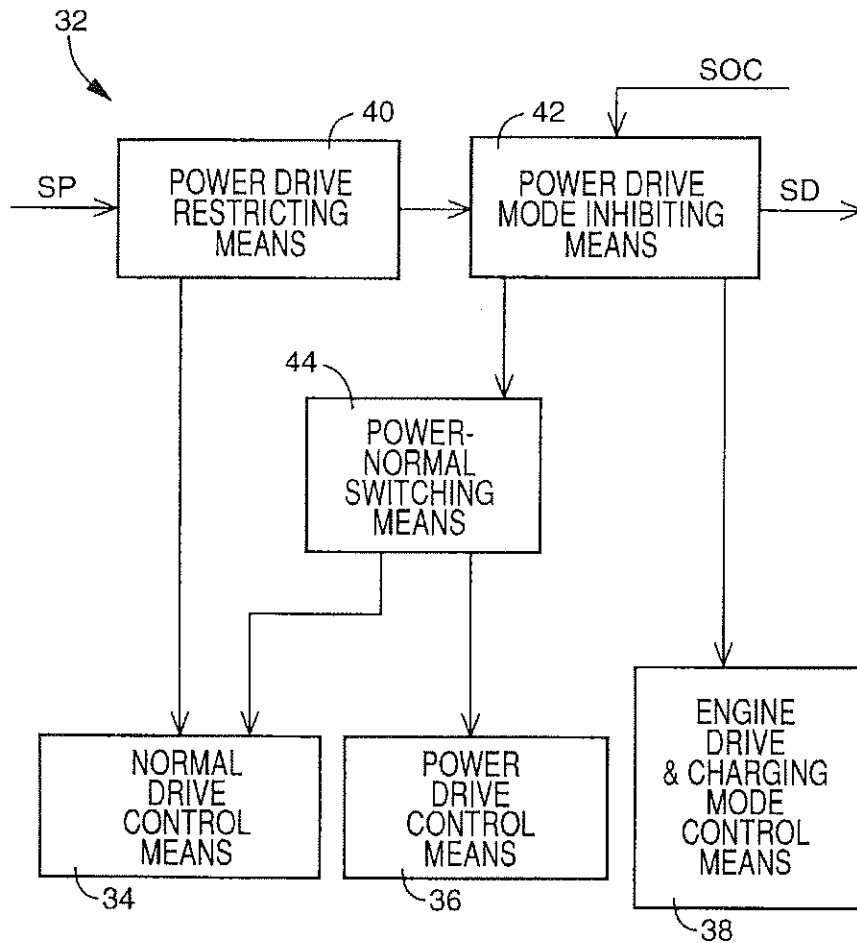

FIG. 3

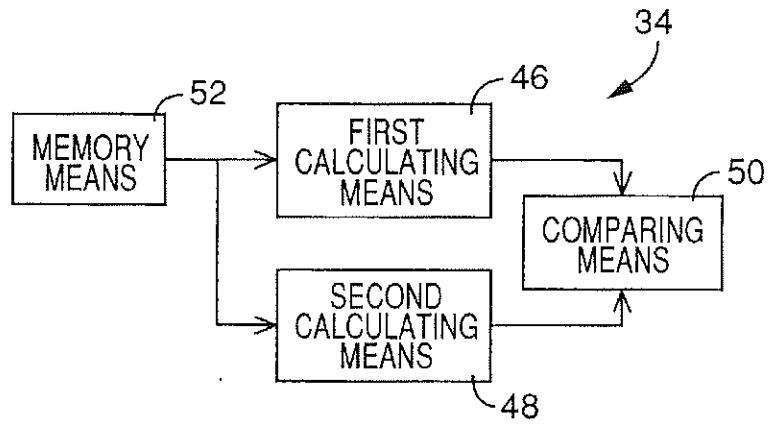

FIG. 4

Explore Litigation Insights

Docket Alarm provides insights to develop a more informed litigation strategy and the peace of mind of knowing you're on top of things.

Real-Time Litigation Alerts



Keep your litigation team up-to-date with **real-time alerts** and advanced team management tools built for the enterprise, all while greatly reducing PACER spend.

Our comprehensive service means we can handle Federal, State, and Administrative courts across the country.

Advanced Docket Research



With over 230 million records, Docket Alarm's cloud-native docket research platform finds what other services can't. Coverage includes Federal, State, plus PTAB, TTAB, ITC and NLRB decisions, all in one place.

Identify arguments that have been successful in the past with full text, pinpoint searching. Link to case law cited within any court document via Fastcase.

Analytics At Your Fingertips



Learn what happened the last time a particular judge, opposing counsel or company faced cases similar to yours.

Advanced out-of-the-box PTAB and TTAB analytics are always at your fingertips.

API

Docket Alarm offers a powerful API (application programming interface) to developers that want to integrate case filings into their apps.

LAW FIRMS

Build custom dashboards for your attorneys and clients with live data direct from the court.

Automate many repetitive legal tasks like conflict checks, document management, and marketing.

FINANCIAL INSTITUTIONS

Litigation and bankruptcy checks for companies and debtors.

E-DISCOVERY AND LEGAL VENDORS

Sync your system to PACER to automate legal marketing.