



US005429070A

United States Patent [19]

[11] Patent Number: **5,429,070**

Campbell et al.

[45] Date of Patent: **Jul. 4, 1995**

- [54] **HIGH DENSITY PLASMA DEPOSITION AND ETCHING APPARATUS**
- [75] Inventors: **Gregor A. Campbell, Glendale; Robert W. Conn, Los Angeles; Dan Katz, Beverly Hills; N. William Parker, Fairfield; Alexis de Chambrier, Glendale, all of Calif.**
- [73] Assignee: **Plasma & Materials Technologies, Inc., Chatsworth, Calif.**
- [21] Appl. No.: **979,574**
- [22] Filed: **Nov. 20, 1992**

5,122,251 6/1992 Campbell et al. 118/723 X

FOREIGN PATENT DOCUMENTS

63-77120 4/1988 Japan 156/345
63-274148 11/1988 Japan .

Primary Examiner—R. Bruce Breneman
Assistant Examiner—Jonathan D. Baskin
Attorney, Agent, or Firm—Skjerven, Morrill, MacPherson, Franklin & Friel; Alan H. MacPherson; David T. Millers

Related U.S. Application Data

- [63] Continuation-in-part of Ser. No. 964,149, Oct. 19, 1992, which is a continuation-in-part of Ser. No. 887,278, May 21, 1992, abandoned, which is a continuation of Ser. No. 650,788, Feb. 4, 1991, Pat. No. 5,122,251, which is a continuation-in-part of Ser. No. 365,533, Jun. 13, 1989, Pat. No. 4,990,229.
- [51] Int. Cl.⁶ **C23C 16/50; H01L 21/00**
- [52] U.S. Cl. **118/723 R; 118/719; 118/723 MP; 118/723 AN; 156/345; 204/298.37; 204/298.38**
- [58] Field of Search **118/723 MP, 723 MW, 118/723 ME, 723 MR, 723 MA, 723 AN, 723 E, 723 ER, 723 IR, 723 R; 156/345; 204/298.37, 298.38**

[57] ABSTRACT

Plasma deposition or etching apparatus is provided which comprises a plasma source located above and in axial relationship to a substrate process chamber. The plasma source may include a sapphire or alumina source tube for use with plasmas containing fluorine. Surrounding the plasma source are an inner magnetic coil and an outer magnetic coil arranged in the same plane perpendicular to the axis of the plasma source and the substrate process chamber. Preferably a first current is provided through the inner coil and a second current in a direction opposite to the direction of the first current is provided through the outer coil. The inner and outer coils are wrapped with a thin sheet of conducting material to shield the coils from RF signal generated by the plasma source. The result is to advantageously shape the magnetic field in the process chamber to achieve extremely uniform processing, particularly when a unique diamond shaped pattern of gas feed lines is used wherein the diamond is arranged to be approximately tangent at four places to the outer circumference of the workpiece being processed in the apparatus.

[56] References Cited U.S. PATENT DOCUMENTS

- 4,433,228 2/1984 Nishimatsu et al. .
- 4,963,242 10/1990 Sato et al. 204/298.37 X
- 4,990,229 2/1991 Campbell et al. 118/723 X
- 5,089,441 2/1892 Moslehi 437/225

13 Claims, 21 Drawing Sheets

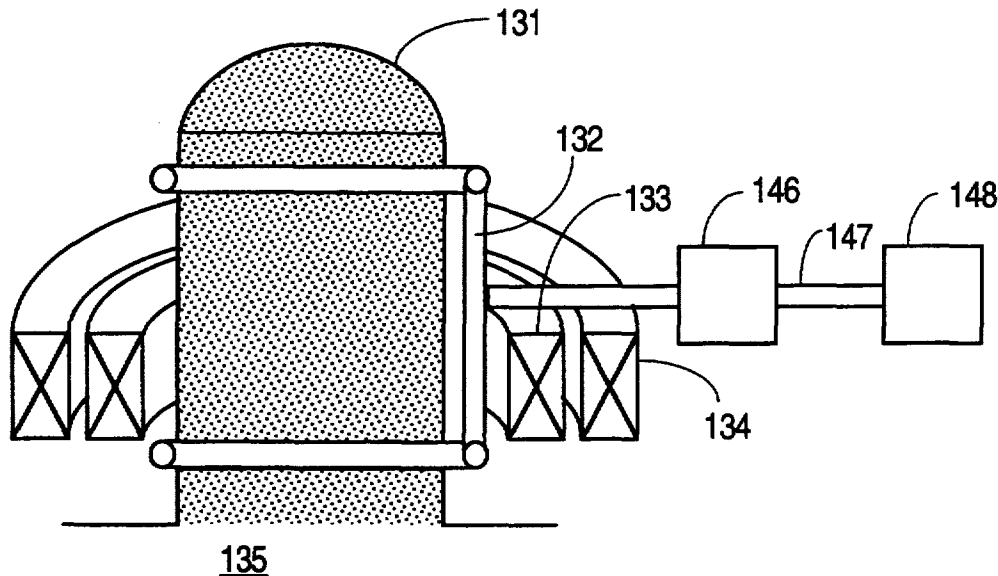

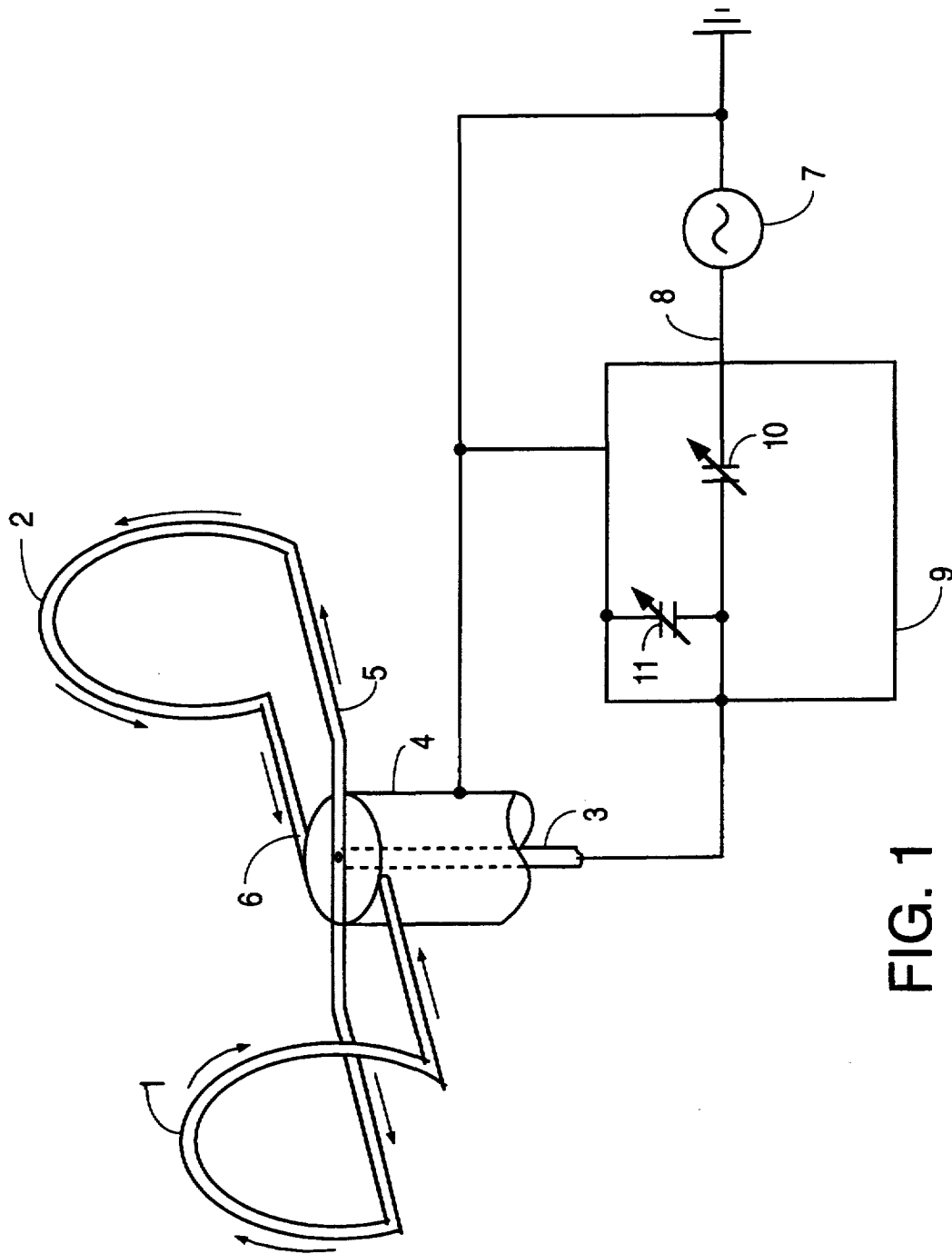

FIG. 1

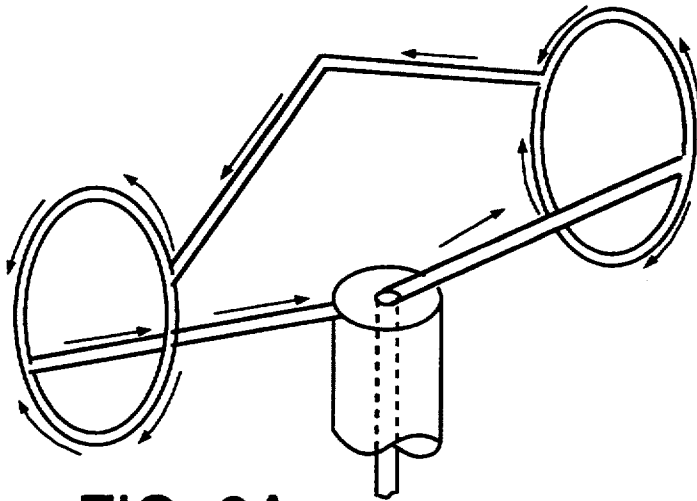

FIG. 2A

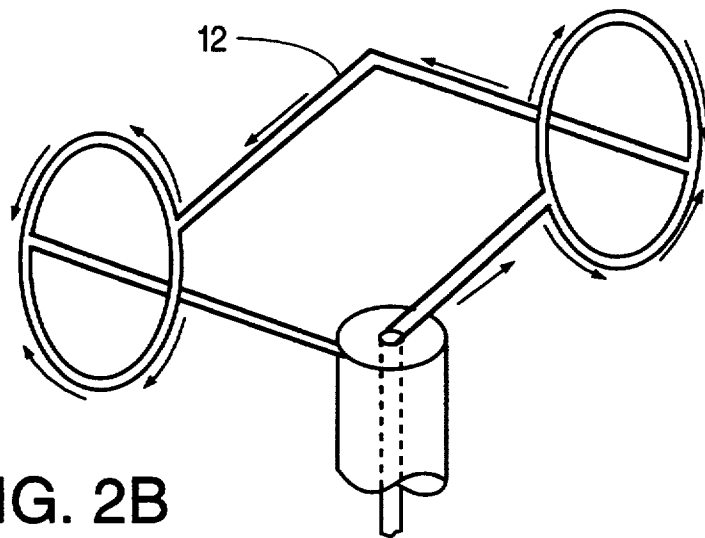

FIG. 2B

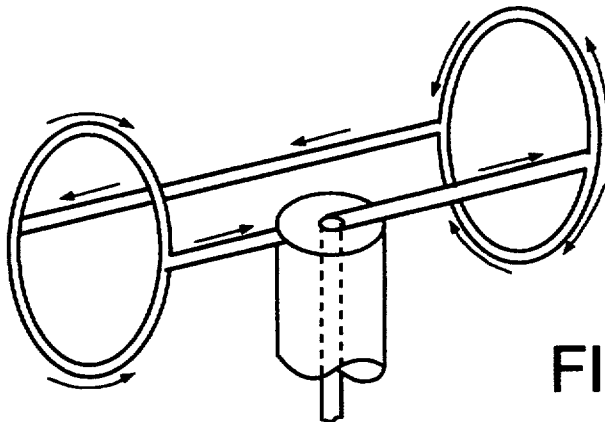

FIG. 2C

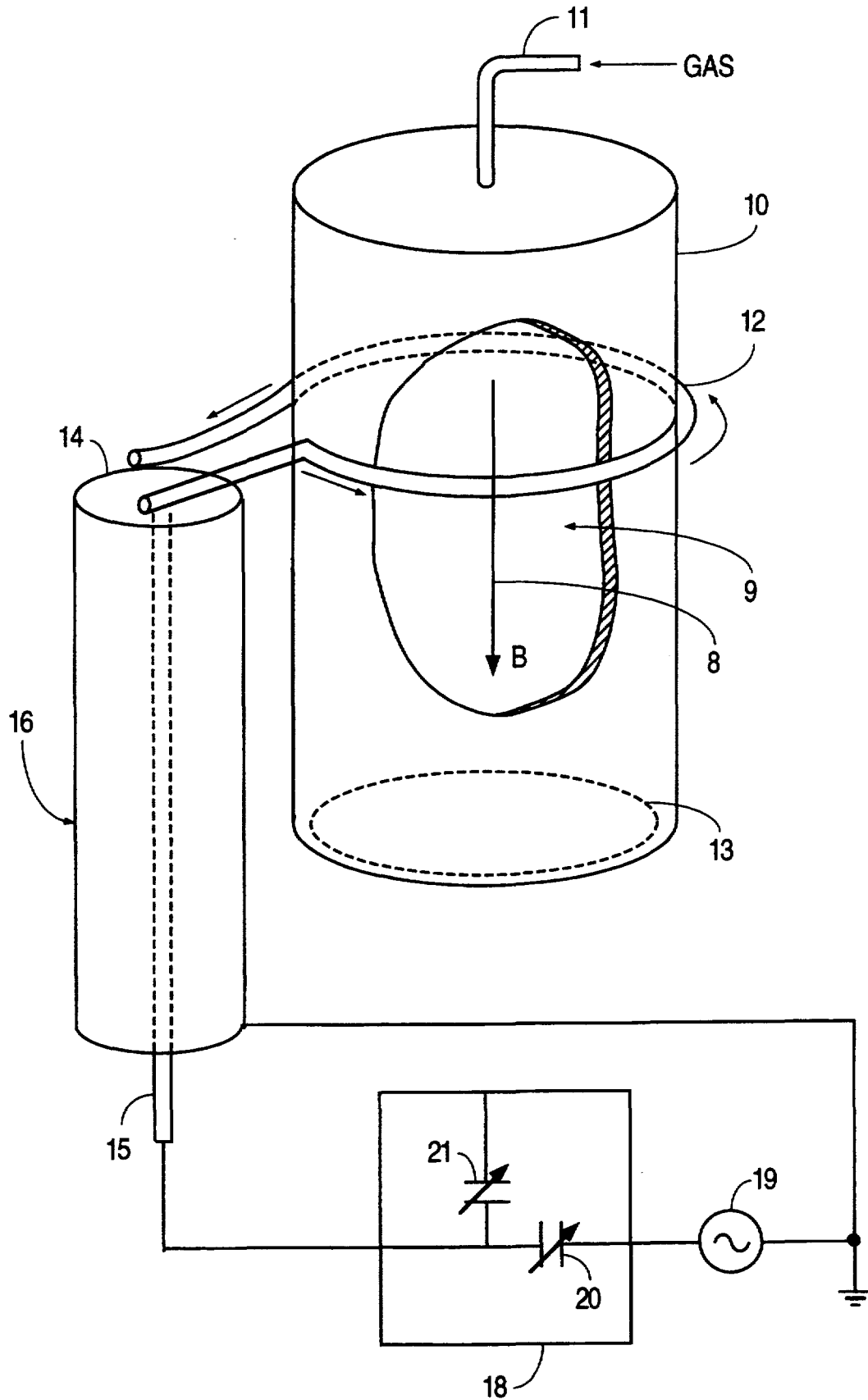

FIG 3

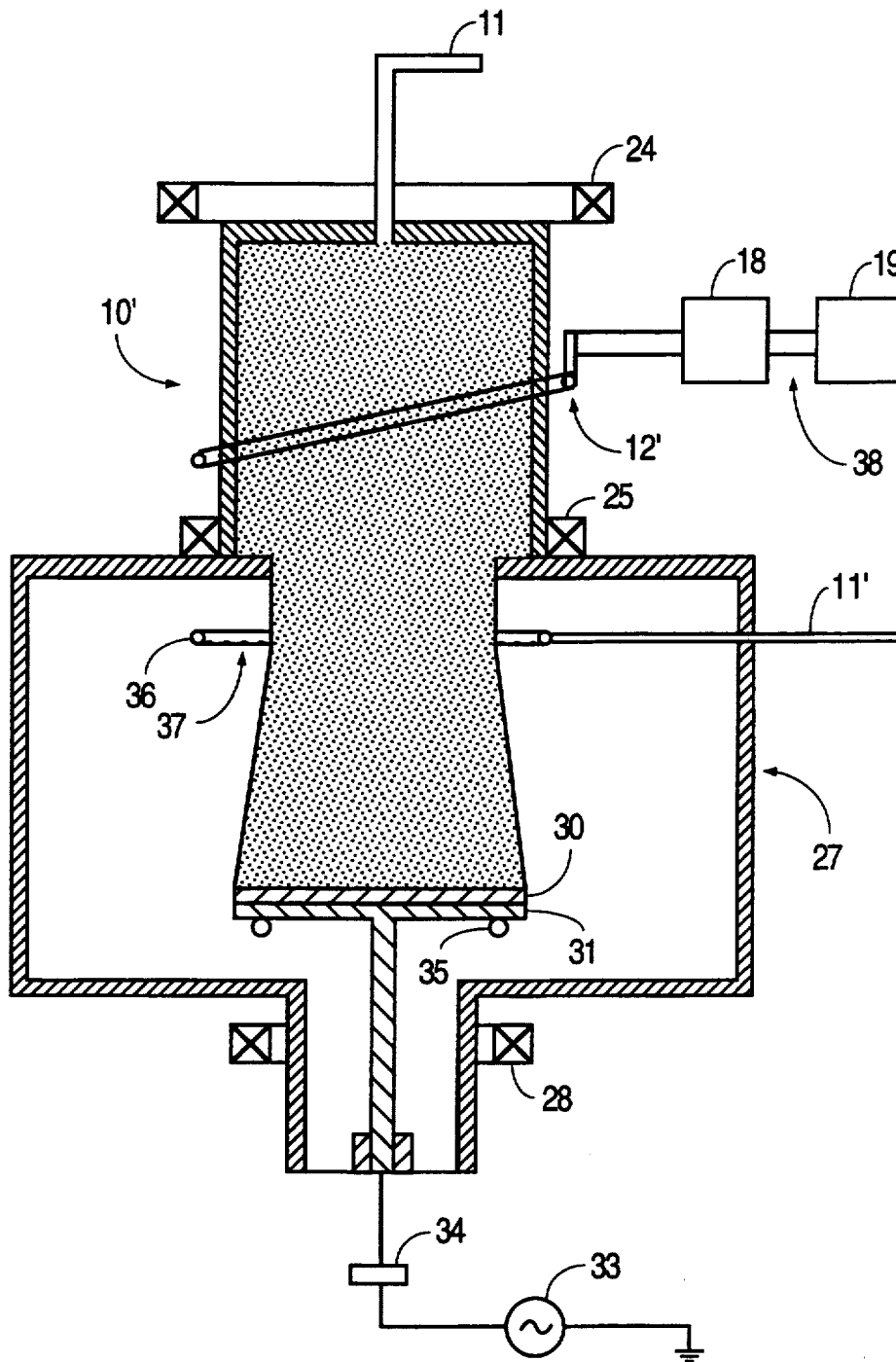

FIG. 4A

Explore Litigation Insights

Docket Alarm provides insights to develop a more informed litigation strategy and the peace of mind of knowing you're on top of things.

Real-Time Litigation Alerts



Keep your litigation team up-to-date with **real-time alerts** and advanced team management tools built for the enterprise, all while greatly reducing PACER spend.

Our comprehensive service means we can handle Federal, State, and Administrative courts across the country.

Advanced Docket Research



With over 230 million records, Docket Alarm's cloud-native docket research platform finds what other services can't. Coverage includes Federal, State, plus PTAB, TTAB, ITC and NLRB decisions, all in one place.

Identify arguments that have been successful in the past with full text, pinpoint searching. Link to case law cited within any court document via Fastcase.

Analytics At Your Fingertips



Learn what happened the last time a particular judge, opposing counsel or company faced cases similar to yours.

Advanced out-of-the-box PTAB and TTAB analytics are always at your fingertips.

API

Docket Alarm offers a powerful API (application programming interface) to developers that want to integrate case filings into their apps.

LAW FIRMS

Build custom dashboards for your attorneys and clients with live data direct from the court.

Automate many repetitive legal tasks like conflict checks, document management, and marketing.

FINANCIAL INSTITUTIONS

Litigation and bankruptcy checks for companies and debtors.

E-DISCOVERY AND LEGAL VENDORS

Sync your system to PACER to automate legal marketing.