



US006805779B2

(12) **United States Patent**  
**Chistyakov**

(10) **Patent No.:** **US 6,805,779 B2**  
(45) **Date of Patent:** **Oct. 19, 2004**

(54) **PLASMA GENERATION USING MULTI-STEP IONIZATION**

(75) Inventor: **Roman Chistyakov, Andover, MA (US)**

(73) Assignee: **Zond, Inc., Mansfield, MA (US)**

(\* ) Notice: Subject to any disclaimer, the term of this patent is extended or adjusted under 35 U.S.C. 154(b) by 0 days.

(21) Appl. No.: **10/249,202**

(22) Filed: **Mar. 21, 2003**

(65) **Prior Publication Data**

US 2004/0182702 A1 Sep. 23, 2004

(51) **Int. Cl.**<sup>7</sup> ..... **C23C 14/00; C23C 16/00; H01J 7/24**

(52) **U.S. Cl.** ..... **204/298.36; 204/298.37; 204/298.38; 118/723 VE; 118/723 R; 315/111.81; 315/111.91**

(58) **Field of Search** ..... **315/111.81, 111.91, 315/111.71, 111.41, 111.21; 204/298.37, 298.38, 298.36; 118/723 VE, 723 R, 723 EB, 723 E; 250/28, 283, 377, 423, 435, 489**

(56) **References Cited**

**U.S. PATENT DOCUMENTS**

3,619,605 A	11/1971	Cook et al. ....	250/41.9
4,060,708 A	11/1977	Walters .....	219/121
4,148,612 A	4/1979	Taylor et al. ....	23/232
4,546,253 A	10/1985	Tsuchiya et al. ....	250/288
4,703,222 A	10/1987	Yoshikawa et al. ....	313/362.1
4,792,725 A	12/1988	Levy et al. ....	315/39
4,802,183 A	1/1989	Harris et al. ....	372/57
4,919,690 A	4/1990	Lovelock .....	55/2
4,953,174 A	8/1990	Eldridge et al. ....	372/87
5,015,493 A	5/1991	Gruen .....	427/38
5,083,061 A	1/1992	Koshiishi et al. ....	315/111.81
5,247,531 A	9/1993	Muller-Horsche .....	372/38
5,247,535 A	9/1993	Muller-Horsche et al. ....	372/86
5,286,360 A	2/1994	Szczyrbowski et al. ....	204/298.08

5,382,457 A	1/1995	Coombe .....	427/596
5,506,405 A	4/1996	Yoshida et al. ....	250/251
5,733,418 A	3/1998	Hersheovitch et al. .	204/192.11
5,821,548 A	10/1998	Hinchliffe .....	250/492.21
6,057,244 A	5/2000	Hausmann et al. ....	438/706

(List continued on next page.)

**FOREIGN PATENT DOCUMENTS**

WO	WO 98/40532	9/1998
WO	WO 01/98553 A1	12/2001

**OTHER PUBLICATIONS**

Booth, et al., The Transition From Symmetric To Asymmetric Discharges In Pulsed 13.56 MHz Capacitively Coupled Plasmas, J. Appl. Phys., Jul. 15, 1997, pp. 552-560, vol. 82, No. 2, American Institute of Physics.

Bunshah, et al., Deposition Technologies For Films And Coatings, pp. 178-183, Noyes Publications, Park Ridge, New Jersey.

Daugherty, et al., Attachment-Dominated Electron-Beam-Ionized Discharges, Applied Physics Letters, May 15, 1976, pp. 581-583, vol. 28, No. 10, American Institute of Physics.

(List continued on next page.)

*Primary Examiner*—Tuyet T. Vo

(74) *Attorney, Agent, or Firm*—Kurt Rauschenbach; Rauschenbach Patent Law Group, LLC

(57) **ABSTRACT**

The present invention relates to a plasma generator that generates a plasma with a multi-step ionization process. The plasma generator includes an excited atom source that generates excited atoms from ground state atoms supplied by a feed gas source. A plasma chamber confines a volume of excited atoms generated by the excited atom source. An energy source is coupled to the volume of excited atoms confined by the plasma chamber. The energy source raises an energy of excited atoms in the volume of excited atoms so that at least a portion of the excited atoms in the volume of excited atoms is ionized, thereby generating a plasma with a multi-step ionization process.

**46 Claims, 13 Drawing Sheets-**

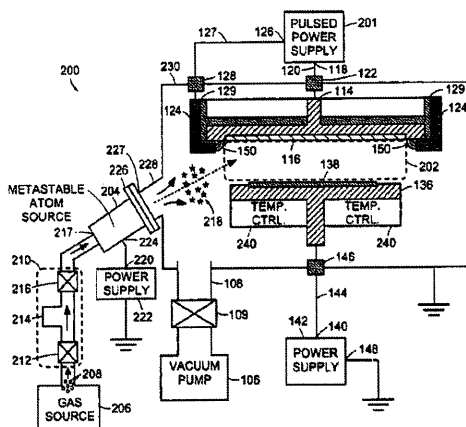

## U.S. PATENT DOCUMENTS

6,124,675 A	9/2000	Bertrand et al.	315/111.91
6,207,951 B1	3/2001	Yamauchi et al.	250/251
6,296,742 B1	10/2001	Kouznetsov	204/192.12
6,311,638 B1 *	11/2001	Ishii et al.	118/723 MW
6,395,641 B2	5/2002	Savas	438/714
6,413,382 B1	7/2002	Wang et al.	204/192.12
6,413,383 B1	7/2002	Chiang et al.	204/192.13
6,661,178 B1 *	12/2003	Bertrand et al.	315/111.91
2002/0153103 A1	10/2002	Madocks	156/345.46

## OTHER PUBLICATIONS

Goto, et al., Dual Excitation Reactive Ion Etcher For Low Energy Plasma Processing, *J. Vac. Sci. Technol. A.*, Sep/Oct 1992, pp. 3048–3054, vol. 10, No. 5, American Vacuum Society.

Kouznetsov, et al., A Novel Pulsed Magnetron Sputter Technique Utilizing Very High Target Power Densities, Surface and Coatings Technology, 1999, pp. 290–293, vol. 122, Elsevier Science S.A.

Lindquist, et al., High Selectivity Plasma Etching Of Silicone Dioxide With A Dual Frequency 27/2 MHz Capacitive RF Discharge.

Macak, Reactive Sputter Deposition Process Of Al<sub>2</sub>O<sub>3</sub> And Characterization Of A Novel High Plasma Density Pulsed Magnetron Discharge, *Linkoping Studies In Science And Technology*, pp. 1–2.

Macak, et al., Ionized Sputter Deposition Using An Extremely High Plasma Density Pulsed Magnetron Discharge, *J. Vac. Sci. Technol. A.*, Jul/Aug 2000, pp. 1533–1537, vol. 18, No. 4, American Vacuum Society.

Mozgrin, et al., High-Current Low-Pressure Quasi-Stationary Discharge In A Magnetic Field: Experimental Research, *Plasma Physics Reports*, 1995, pp. 400–409, vol. 21, No. 5.

Rosnagel, et al., Induced Drift Currents In Circular Planar Magnetrons, *J. Vac. Sci. Technol. A.*, Jan/Feb 1987, pp. 88–91, vol. 5, No. 1, American Vacuum Society.

Sheridan, et al., Electron Velocity Distribution Functions In A Sputtering Magnetron Discharge For The E × B Direction, *J. Vac. Sci. Technol. A.*, Jul/Aug 1998, pp. 2173–2176, vol. 16, No. 4, American Vacuum Society.

Steinbruchel, A Simple Formula For Low-Energy Sputtering Yields, *Appl. Phys. A.*, 1985, pp. 37–42, vol. 36, Sprigner Verlag.

*Encyclopedia Of Low Temperature Plasma*, p. 119, vol. 3.

*Encyclopedia Of Low Temperature Plasma*, p. 123, vol. 3.

Lymberopoulos, et al., Fluid Simulations Of Glow Discharges: Effect Of Metastable Atoms In Argon, *J. Appl. Phys.*, Apr. 1993, pp. 3668–3679, vol. 73, No. 8, American Institute of Physics.

Burnham, et al., Efficient Electric Discharge Lasers In XeF and KrF, *Applied Physics Letters*, Jul. 1976, pp. 30–32, vol. 29, No. 1, American Institute of Physics.

Fabrikant, et al., Electron Impact Formation Of Metastable Atoms, pp. 3, 31, 34–37, Amsterdam.

Fahey, et al., High Flux Beam Source Of Thermal Rare-Gas Metastable Atoms, 1980, *J. Phys. E. Sci. Instrum.*, vol. 13, The Institute of Physics.

Verheijen, et al., A Discharge Excited Supersonic Source Of Metastable Rare Gas Atoms, *J. Phys. E. Sci. Instrum.*, 1984, vol. 17.

Eletskii, Excimer Lasers, *Sov. Phys. Usp.*, Jun. 1978, pp. 502–521, vol. 21, No. 6.

Chistyakov, High Power Pulsed Magnetron Sputtering, Application No.: 10/065, 277, Filed: Sep. 30, 2002.

Chistyakov, High-Power Pulsed Magnetically Enhanced Plasma Processing, Application No.: 10/065, 551, Filed: Oct. 29, 2002.

Chistyakov, Method and Apparatus For Generating High-Density Plasma, Application No.: 10/065, 629, Filed: Nov. 4, 2002.

Chistyakov, High Deposition Rate Sputtering, Application No.: 10/065, 739, Filed: Nov. 14, 2002.

\* cited by examiner

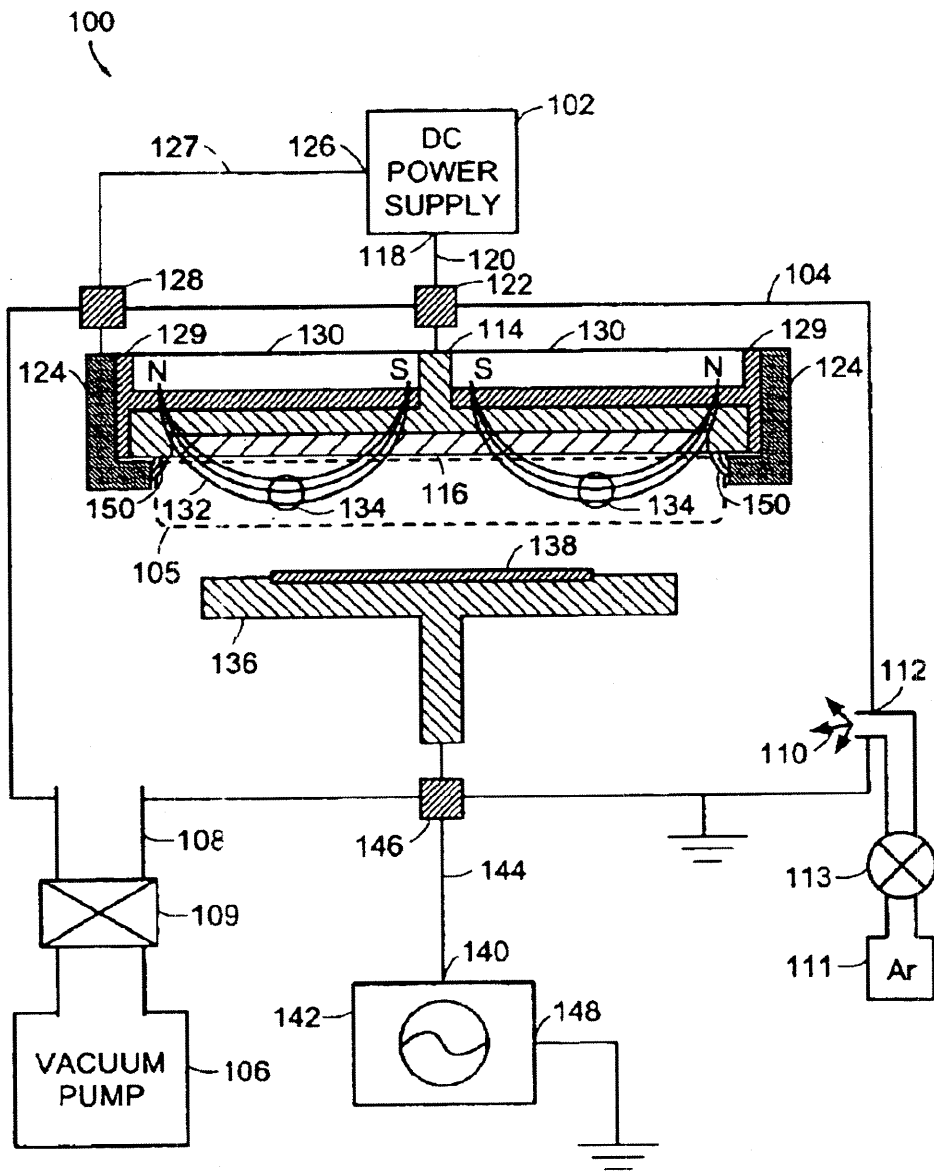

FIG. 1  
PRIOR ART



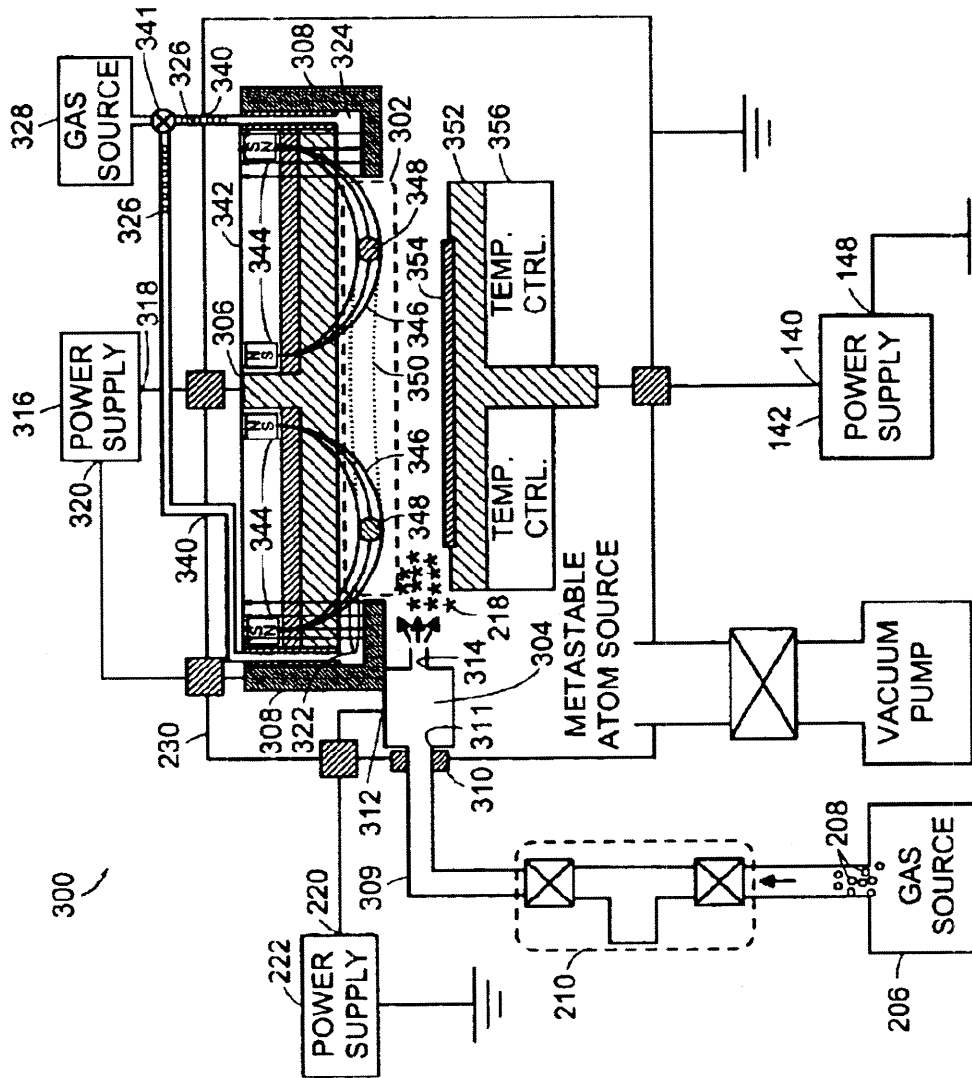

FIG. 3

# Explore Litigation Insights

Docket Alarm provides insights to develop a more informed litigation strategy and the peace of mind of knowing you're on top of things.

## Real-Time Litigation Alerts



Keep your litigation team up-to-date with **real-time alerts** and advanced team management tools built for the enterprise, all while greatly reducing PACER spend.

Our comprehensive service means we can handle Federal, State, and Administrative courts across the country.

## Advanced Docket Research



With over 230 million records, Docket Alarm's cloud-native docket research platform finds what other services can't. Coverage includes Federal, State, plus PTAB, TTAB, ITC and NLRB decisions, all in one place.

Identify arguments that have been successful in the past with full text, pinpoint searching. Link to case law cited within any court document via Fastcase.

## Analytics At Your Fingertips



Learn what happened the last time a particular judge, opposing counsel or company faced cases similar to yours.

Advanced out-of-the-box PTAB and TTAB analytics are always at your fingertips.

## API

Docket Alarm offers a powerful API (application programming interface) to developers that want to integrate case filings into their apps.

## LAW FIRMS

Build custom dashboards for your attorneys and clients with live data direct from the court.

Automate many repetitive legal tasks like conflict checks, document management, and marketing.

## FINANCIAL INSTITUTIONS

Litigation and bankruptcy checks for companies and debtors.

## E-DISCOVERY AND LEGAL VENDORS

Sync your system to PACER to automate legal marketing.