



(12) **EUROPEAN PATENT APPLICATION**

(43) Date of publication:
04.07.2001 Bulletin 2001/27

(51) Int Cl.7: **C23C 14/35, H01J 37/34**

(21) Application number: **00126120.5**

(22) Date of filing: **29.11.2000**

(84) Designated Contracting States:
**AT BE CH CY DE DK ES FI FR GB GR IE IT LI LU
MC NL PT SE TR**
Designated Extension States:
AL LT LV MK RO SI

(72) Inventors:
• **Yamaguchi, Hirohito**
Ohta-ku, Tokyo (JP)
• **Kanaï, Masahiro**
Ohta-ku, Tokyo (JP)
• **Koike, Atsushi**
Ohta-ku, Tokyo (JP)
• **Oya, Katsunori**
Ohta-ku, Tokyo (JP)

(30) Priority: **30.11.1999 JP 33924199**
28.04.2000 JP 2000131042
28.06.2000 JP 2000194476
04.07.2000 JP 2000202225
04.08.2000 JP 2000237317
04.08.2000 JP 2000237318

(74) Representative:
Leson, Thomas Johannes Alois, Dipl.-Ing. et al
Patentanwälte
Tiedtke-Bühling-Kinne & Partner,
Bavariaring 4
80336 München (DE)

(71) Applicant: **CANON KABUSHIKI KAISHA**
Tokyo (JP)

(54) **Method and apparatus for coating by plasma sputtering**

(57) The present invention provides a film forming method comprising the steps of ionizing sputtering particles and applying a periodically changing voltage to an electrode near a substrate, wherein a time for applying a voltage equal to or higher than an intermediate value between maximum and minimum values of the periodically changing voltage is shorter than a time for applying a voltage equal to or less the intermediate value, and a film forming apparatus for carrying out the above method.

FIG. 1

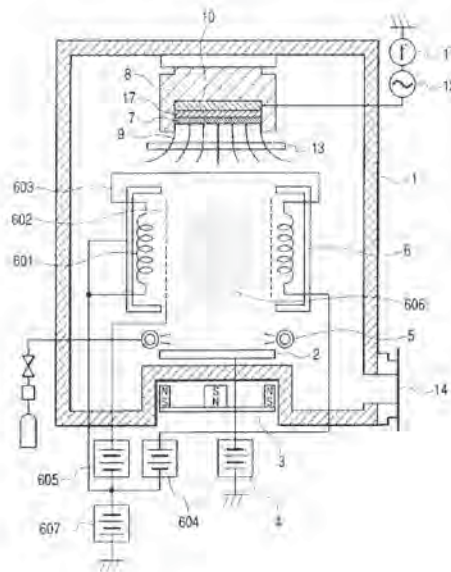

P 1 113 088 A1

Description

BACKGROUND OF THE INVENTION

3 Field of the Invention

[0001] The present invention relates to a film-forming method and apparatus which can be used to produce semiconductor devices, such as LSIs, and recording media, such as magneto-optical disks, and more particularly, to an ionization film-forming method and apparatus which can form various types of deposited films by using ionized particles.

10

Related Background Art

[0002] Film-forming methods are used to form wirings and interlayer insulating films on a variety of semiconductor devices or form magnetic and protective layers on recording media. These film-forming methods, which must exhibit various types of performance, have recently been required to provide a film having an improved coverage of an inside of a groove formed in a substrate, especially a bottom of the groove.

15

[0003] Fig. 5 shows a cross section of a film deposited by a conventional sputtering method. The film 102 on the bottom 104 of a groove is by far thinner than the film 100 on a top portion 103 of a substrate 7 outside the groove. This means that the sputtering method provides poor coverage. Fig. 5 also shows that a film is deposited on the side 101 of the groove. Poor coverage and film formation on the side of a groove adversely affect film formation on a substrate.

20

[0004] Below is described a magneto-optical disk of a magnetic domain wall displacement type, which is disclosed in Japanese Patent Application Laid-Open No. 6-290496. Grooves which are concentrically formed in conventional magneto-optical disks and compact disks are not used to record information. However, because information is recorded also on the bottom of a groove in a recording medium of a magnetic domain wall displacement type, a functional film must be formed on the bottom similarly as on the flat parts (hereinafter, referred to as "lands") of the medium outside the groove. In addition, the medium must be adapted so that no magneto-optical signal is produced from the side of the groove, which separates the bottom of the groove and the lands, to prevent interference between the groove and the lands. To do so, a deposition amount of a film on the side of the groove must be minimized. That is, a recording medium of a magnetic domain wall displacement type requires film formation which is highly directional and has a high bottom coverage ratio. The bottom coverage ratio is defined as the ratio of a film formation rate on the bottom surface of the groove to a film formation rate on a surface outside the groove. The bottom coverage ratio can be obtained by the formula of $t_A/t_B \times 100$ (%), wherein t_A is the thickness of a film formed on the bottom surface of a groove and t_B is the thickness of a film formed on a surface outside the groove (see Fig. 4).

25

30

[0005] Conventional film forming methods which provide a high bottom coverage ratio include the low-pressure remote sputtering method, collimate sputtering method, and a high-frequency plasma assisted sputtering method which is disclosed in Japanese Patent Application Laid-Open No. 10-259480.

35

[0006] The low-pressure remote sputtering method allows sputtering particles to fly straight without scattering because the method uses a lower pressure and a longer mean free path than ordinary sputtering methods. The low-pressure remote sputtering method is also adapted to provide a longer distance between a target and a substrate and make particles fly at a right angle to the substrate.

40

[0007] The collimate sputtering method makes only sputtering particles flying at a right angle to a substrate to reach it and deposits the particles thereon by placing a cylinder having a plurality of holes made at a right angle to the substrate between a target and the substrate.

45

[0008] The high-frequency plasma assisted sputtering method allows flying sputtering particles to deposit by ionizing them in a space of plasma, which is produced near a substrate by applying a high-frequency voltage to the substrate, and directing the ionized sputtering particles at a right angle to the substrate, using a negative voltage (self bias) produced on the substrate due to plasma.

[0009] However, the low-pressure remote sputtering method is said to be limited to substrates with a groove aspect ratio up to about 4 in mass production because of its low film formation rate and low raw-material (target) use efficiency due to the long distance between the target and substrate.

50

[0010] The collimate sputtering method has a problem of low film formation rate and low raw-material use efficiency due to a loss caused by sputtering particles deposited on the collimator, and is limited to substrates with a groove aspect ratio up to about 3.

[0011] The high-frequency plasma assisted sputtering method can be used for substrates with a groove aspect ratio of 4 or more. However, the sputtering method allows charged particles in plasma to penetrate a substrate, thus heating it because plasma is produced by applying a high-frequency voltage to the substrate. Thus in the sputtering method, it is difficult to form a film on a substrate made of a material which has low heat resistance, such as resin used as the substrate material for recording media, including compact disks and magneto-optical disks.

55

SUMMARY OF THE INVENTION

[0012] It is an object of the present invention, intended to solve the above-described problems, to provide a film forming method and film forming apparatus which can be used to form a film at a high bottom coverage ratio even on a substrate with deep grooves on its surface.

[0013] It is another object of the present invention to provide a film forming method and a film forming apparatus which can prevent substrate temperature from increasing.

[0014] It is still another object of the present invention to provide an ionization film forming method and an ionization film forming apparatus which promote discharge gas excitation and ionization, thereby increasing the efficiency of ionization of evaporated particles.

[0015] These objects are attained by a method for forming a deposited film by sputtering, comprising the steps of:

ionizing sputtering particles and
applying a periodically changing voltage to an electrode provided near a substrate,

wherein a time for which a voltage equal to or larger than an intermediate value between maximum and minimum values of the above-described voltage is applied is shorter than a time for which a voltage equal to or smaller than the intermediate value is applied.

[0016] The objects are also attained by an ionization sputtering apparatus for forming a deposited film by directing sputtering particles to a substrate using an electric field produced near the substrate, comprising:

a sputtering chamber with an evacuating system;
gas introducing means for introducing a processing gas into the sputtering chamber;
a target placed in the sputtering chamber;
ionizing means provided between the target and the substrate;
an electrode disposed near the substrate; and
voltage applying means for applying a periodically changing voltage to the electrode under such a condition that the time for which a voltage equal to or larger than an intermediate value between maximum and minimum values of the applied voltage is applied is shorter than the time for which a voltage equal to or smaller than the intermediate value is applied. Detailed descriptions will be given later with reference to examples.

BRIEF DESCRIPTION OF THE DRAWINGS

[0017]

Fig. 1 is a schematic sectional view illustrating a structure of a film forming apparatus according to an embodiment of the present invention;

Fig. 2 is a schematic sectional view illustrating an embodiment of an ionizing mechanism of the present invention;

Fig. 3 shows a waveform of a voltage applied to an electrode 10 according to the present invention;

Fig. 4 is a schematic view illustrating a method for calculating a bottom coverage ratio according to the present invention;

Fig. 5 is a sectional view of a film deposited by a conventional sputtering method;

Fig. 6 shows a relationship between a frequency of voltage applied to the electrode 10 and the bottom coverage ratio in Example 3 of the present invention;

Fig. 7 shows a relationship between a duty ratio of the voltage applied to the electrode 10 (the ratio of a time T1 for which a voltage V1 is applied to a time T2 for which a voltage V2 is applied, as shown in Fig. 3) and the bottom coverage ratio in Example 4 of the present invention;

Fig. 8 shows a relationship between the duty ratio of a voltage applied to the electrode 10 and a dielectric strength in Example 6 of the present invention;

Fig. 9 is a schematic sectional view illustrating the structure of an ionization film-forming apparatus in Example 8 of the present invention;

Fig. 10 is a schematic view illustrating magnetic lines of force which are formed when magnetic-field applying means installed in the ionization film-forming apparatus in Example 8 of the present invention is singly used;

Fig. 11 is a schematic view illustrating magnetic lines of force which are formed by the magnetic-field applying means between a target and an ionizing mechanism and by magnetic-field applying means below the target in Fig. 9;

Fig. 12 is a schematic sectional view illustrating the structure of an ionization film-forming apparatus in Example 11 of the present invention;

Fig. 13 is a schematic sectional view illustrating the structure of an ionization film-forming apparatus in Example 15 of the present invention;

Fig. 14 is a schematic sectional view illustrating the structure of an ionization film-forming apparatus in Example 18 of the present invention;

Fig. 15 is a schematic sectional view illustrating the structure of an ionization film-forming apparatus in Example 20 of the present invention;

Fig. 16 shows a relationship between the size ratio between a substrate and the electrode 10 and the bottom coverage ratio in Example 20 of the present invention;

Fig. 17 shows a relationship between the size ratio between a substrate and the electrode 10 and the bottom coverage ratio in Example 21 of the present invention;

Fig. 18 is a schematic sectional view illustrating the structure of an ionization film-forming apparatus in Example 22 of the present invention;

Figs. 19A and 19B are a top view of ionizing means 6 in an ionization film-forming apparatus in Example 22 of the present invention and a side view of the apparatus, respectively;

Fig. 20 illustrates relationships between a film forming time and a substrate temperature which are established in cases where a shield plate is provided, the shield plate is cooled, and no shield plate is provided in Example 22 of the present invention;

Fig. 21 illustrates differences in the bottom coverage ratio depending on whether shield plates made of glass, Teflon, and polycarbonate are water-cooled or not;

Fig. 22 is a schematic sectional view illustrating the structure of an ionization film-forming apparatus in Example 25 of the present invention;

Fig. 23 is a sectional view of a substrate on which a film is formed in Example 25 of the present invention;

Fig. 24 shows the results of CN ratio measurements using a magnetic domain wall displacement type recording medium in Example 25 of the present invention;

Fig. 25 is a schematic sectional view illustrating another embodiment of the ionization film-forming apparatus in Example 25 of the present invention; and

Fig. 26 is a graph for showing the dependency of a magnetic flux density at point A on the rate of forming a deposited film on a substrate.

DETAILED DESCRIPTION OF THE PREFERRED EMBODIMENTS

[0018] Referring now to the drawings, the present invention will be described below.

[0019] Fig. 1 is a schematic view illustrating an ionization film-forming apparatus according to an embodiment of the present invention. In Fig. 1, a reference numeral 10 indicates an electrode on the back side of a substrate, and reference numerals 11 and 12 indicate voltage applying means for applying a periodically changing voltage to the electrode 10.

[0020] According to a film forming mechanism of the present invention, particles evaporated from a target 2 are ionized using an ionizing mechanism 6, and the ionized sputtering particles with directivity are incident on a substrate 7 under the action of an electric field 9 on the substrate 7.

[0021] A film forming chamber 1, which is a metal container made of stainless steel, aluminum, or the like, is grounded to be at a reference electric potential and is kept airtight by a gate valve not shown.

[0022] An evacuating system 14 is a complex evacuator which can evacuate in a range of the atmospheric pressure to about 10^{-6} Pa. The evacuation speed of the evacuating system can be adjusted using an evacuation speed adjuster, not shown, such as an orifice or a conductance valve.

[0023] For the embodiment, the target 2 is a disk 3 mm thick and about 3 inches (76.2 mm) in diameter, which is installed through a backing plate and an insulator in a sputtering chamber 1. A mechanism may be provided which cools the target as required, using a refrigerant, such as water.

[0024] A magnet 3 as magnetic-field producing means is installed on the back side of the target 2 so that magnetron sputtering can be carried out.

[0025] A sputtering power supply 4, which feeds a predetermined electric power to the target 2 to cause glow discharge, is adapted to apply to the target 2 a negative DC voltage of -200 V or -600 V with respect to the reference voltage.

[0026] Processing gas introducing means 5 introduces a sputtering discharge gas, such as a rare gas. Because the gas is efficiently ionized, it is preferable that the processing gas be introduced at the center of an ionizing space. A circular pipe with many gas blow-out holes formed on its center side is more preferably used because the gas is uniformly introduced.

[0027] The ionizing mechanism 6, which is of a hot cathode type using Penning ionization, ionizes sputtering ions by hitting thermoelectrons, emitted from a hot cathode, against sputtering particles and sputtering discharge gas particles in an ionizing space 606 provided in a sputtering particle travel path from the target 2 to the substrate 7 or produces sputtering discharge gas excitation seeds and ions. Discharge gas excitation seeds and ions also collide

with sputtering particles in the ionizing space to ionize the sputtering particles. As described above, sputtering particles are ionized mainly through the two mechanisms.

[0028] Fig. 2 shows the structure of the ionizing mechanism 6. Specifically, by feeding current from a DC power supply 604 to a filament 601 connected thereto in series, the ionizing mechanism 6 heats the filament 601, thereby making it emit thermoelectrons. A grid 602 has a network structure. A DC power supply 605 applies a positive voltage thereto, so that thermoelectrons from the filament 601 are accelerated toward the grid 602. The thermoelectrons accelerated are not immediately captured by the grid 602 but travels through the grid 602 the ionizing space 606 in the travel path of sputtering particles. The thermoelectrons collide with sputtering particles and sputtering discharge gas particles to ionize or excite these particles and then are captured by the grid 602. The filament 601 is made of a material with a large coefficient of thermoelectron emission, such as ReW or W, and the grid 602 has a network structure, consisting of wires, for example, 1 mm in diameter which are spaced about 3 mm apart from each other. For the ionizing mechanism, one side of the filament 601 is at the same potential as a casing 603. Thus a DC voltage which is negative with respect to a reference voltage may be applied to the casing 603 by a DC power supply 607 to prevent electron diffusion, or the casing 603 may be kept at the reference potential.

[0029] A substrate holder 8, disposed in the chamber 1, is adapted so that the holder can keep the substrate 7 parallel to the target 2. An insulator 17 is interposed between the substrate holder 8 and the substrate 7. The electrode 10 is preferably installed in parallel with the substrate 7.

[0030] The electrode 10 is connected with voltage applying means consisting of a function synthesizer 11, serving as a signal generator, and a power amplifier 12. The voltage applying means applies periodically changing voltage to the electrode 10.

[0031] Fig. 3 exemplifies a bias voltage applied to the electrode 10. The bias voltage varies in a predetermined period between a maximum voltage V1 (a voltage at which the amplitude takes a minimum with respect to a floating potential) and a minimum voltage V2 (a voltage at which the amplitude takes maximum with respect to a floating potential). The floating potential is a potential which an electrically insulated substrate placed in plasma generates under the action of plasma. In this embodiment, the floating potential is a potential generated at the substrate 7 when no voltage is applied to the electrode 10.

[0032] Such a bias voltage produces an electric field 9 near the substrate 7 substantially at a right angle to the substrate 7, so that ionized sputtering particles are accelerated along the electric field 9 to reach the substrate 7. Because ionized particles are incident on the substrate 7 in the direction of the electric field 9, it is desirable that the electric field 9 be uniformly formed over the substrate as directed at a right angle to the substrate as possible. Any waveform and voltage can be applied from the signal generator 11 and power amplifier 12 to the electrode 10.

[0033] An ionization film-forming method according to an embodiment of the present invention will be described below.

[0034] After the substrate 7 is installed in the substrate holder 8, the chamber is evacuated to about 10^{-6} Pa using the complex evacuating system 14. Then the ionizing mechanism 6 is operated. That is, first, the DC power supply 607 is operated and set to a value. Next, the filament DC power supply 604 is operated to heat the filament 601 by energizing it. Finally, using the grid DC power supply 605, a positive DC voltage of about +10 to about +200 V is applied to the grid 602 to cause it to emit thermoelectrons in the ionizing space 606.

[0035] Depending on the rate of film formation by sputtering, it is desirable that the value of a current (emission current) flowing into the grid 602 be set to 5A or more during film formation.

[0036] Then using the processing gas introducing means 5, a sputtering gas such as Ar is introduced, and the evacuation speed adjuster for the complex evacuating system 14 is controlled to keep the chamber 1 at 0.2 to 2.5 Pa. Next, by operating the sputtering power supply 4, sputtering discharge is performed to start sputtering. At the same time, by operating the signal generator 11 and the power amplifier 12, a periodically changing voltage is applied to the electrode 10 to produce the electric field 9 substantially perpendicular to the surface of the substrate 7.

[0037] For example, a voltage which has the rectangular waveform in Fig. 3 is applied to the electrode 10 as described above so that electrons can be incident on the substrate at the maximum voltage V1 near the rectangular-wave floating potential. Specifically, it is desirable that the maximum voltage V1 be chosen within the range of 0 to -10 V because the floating potential is often within or around the range. Depending on sputtering conditions, the floating potential may be more than -0 V. In this case, the maximum voltage V1 should be chosen according to the floating potential. As described above, as a voltage applied near the substrate 7, which is determined on basis of the maximum voltage V1 around the floating potential or above it is applied so that electrons can be incident on the substrate, and the minimum voltage V2 is applied so that positive ions can be incident on the substrate. In addition, to prevent a film formation rate from significantly decreasing under the effect of reverse sputtering, it is desirable that the minimum voltage V2 be set to -20 to -100 V.

[0038] To make ions efficiently incident on the substrate while preventing substrate charge-up, it is desirable that the frequency be 100 kHz or more and that the waveform duty ratio be set to 1:50 or more, that is, the ratio of the time for which the maximum voltage V1 is applied to the time for which the minimum voltage V2 is applied be set to 1/50 or less.

Explore Litigation Insights

Docket Alarm provides insights to develop a more informed litigation strategy and the peace of mind of knowing you're on top of things.

Real-Time Litigation Alerts



Keep your litigation team up-to-date with **real-time alerts** and advanced team management tools built for the enterprise, all while greatly reducing PACER spend.

Our comprehensive service means we can handle Federal, State, and Administrative courts across the country.

Advanced Docket Research



With over 230 million records, Docket Alarm's cloud-native docket research platform finds what other services can't. Coverage includes Federal, State, plus PTAB, TTAB, ITC and NLRB decisions, all in one place.

Identify arguments that have been successful in the past with full text, pinpoint searching. Link to case law cited within any court document via Fastcase.

Analytics At Your Fingertips



Learn what happened the last time a particular judge, opposing counsel or company faced cases similar to yours.

Advanced out-of-the-box PTAB and TTAB analytics are always at your fingertips.

API

Docket Alarm offers a powerful API (application programming interface) to developers that want to integrate case filings into their apps.

LAW FIRMS

Build custom dashboards for your attorneys and clients with live data direct from the court.

Automate many repetitive legal tasks like conflict checks, document management, and marketing.

FINANCIAL INSTITUTIONS

Litigation and bankruptcy checks for companies and debtors.

E-DISCOVERY AND LEGAL VENDORS

Sync your system to PACER to automate legal marketing.